

SN74LVC8T245 8-Bit Dual-Supply Bus Transceiver With Configurable Voltage Translation and 3-State Outputs

1 Features

- Control Inputs V_{IH}/V_{IL} Levels Are Referenced to V_{CCA} Voltage
- V_{CC} Isolation Feature – If Either V_{CC} Input Is at GND, All Are in the High-Impedance State
- Fully Configurable Dual-Rail Design Allows Each Port to Operate Over the Full 1.65-V to 5.5-V Power-Supply Range
- Latch-Up Performance Exceeds 100 mA Per JESD 78, Class II
- ESD Protection Exceeds JESD 22
 - 4000-V Human-Body Model (A114-A)
 - 100-V Machine Model (A115-A)
 - 1000-V Charged-Device Model (C101)

2 Applications

- Personal Electronic
- Industrial
- Enterprise
- Telecom

3 Description

This 8-bit noninverting bus transceiver uses two separate configurable power-supply rails. The SN74LVC8T245 is optimized to operate with V_{CCA} and V_{CCB} set at 1.65 V to 5.5 V. The A port is designed to track V_{CCA} . V_{CCA} accepts any supply voltage from 1.65 V to 5.5 V. The B port is designed to track V_{CCB} . V_{CCB} accepts any supply voltage from 1.65 V to 5.5 V. This allows for universal low-voltage bidirectional translation between any of the 1.8-V, 2.5-V, 3.3-V, and 5.5-V voltage nodes.

The SN74LVC8T245 is designed for asynchronous communication between two data buses. The logic levels of the direction-control (DIR) input and the output-enable (\overline{OE}) input activate either the B-port outputs or the A-port outputs or place both output ports into the high-impedance mode. The device transmits data from the A bus to the B bus when the B-port outputs are activated, and from the B bus to the A bus when the A-port outputs are activated. The input circuitry on both A and B ports is always active and must have a logic HIGH or LOW level applied to prevent excess I_{CC} and I_{CCZ} .

The SN74LVC8T245 is designed so that the control pins (DIR and \overline{OE}) are supplied by V_{CCA} .

Device Information⁽¹⁾

PART NUMBER	PACKAGE	BODY SIZE (NOM)
SN74LVC8T245	SSOP (24)	8.20 mm x 5.30 mm
	SSOP (24)	8.65 mm x 3.90 mm
	TSSOP (24)	7.80 mm x 4.40 mm
	TVSOP (24)	5.00 mm x 4.40 mm
	VQFN (24)	5.50 mm x 3.50 mm

(1) For all available packages, see the orderable addendum at the end of the datasheet.

4 Logic Diagram (Positive Logic)

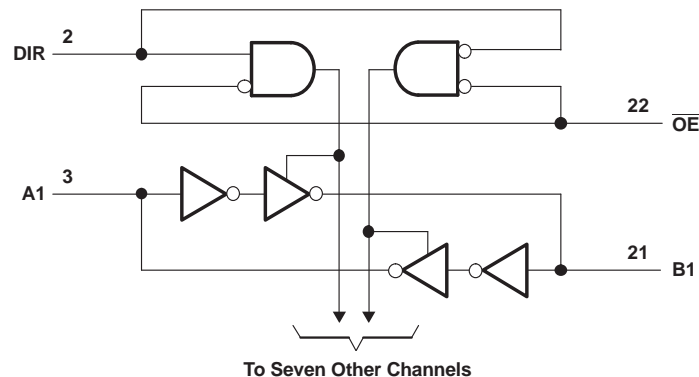

Table of Contents

1 Features	1	8.12 Typical Characteristics	11
2 Applications	1	9 Parameter Measurement Information	12
3 Description	1	10 Detailed Description	13
4 Logic Diagram (Positive Logic)	1	10.1 Overview	13
5 Revision History	2	10.2 Functional Block Diagram	13
6 Description (continued)	3	10.3 Feature Description	13
7 Pin Configuration and Functions	4	10.4 Device Functional Modes	13
8 Specifications	5	11 Application and Implementation	14
8.1 Absolute Maximum Ratings	5	11.1 Application Information	14
8.2 Handling Ratings	5	11.2 Typical Application	14
8.3 Recommended Operating Conditions	6	12 Power Supply Recommendations	15
8.4 Thermal Information DB, DBQ and DGV	7	13 Layout	16
8.5 Thermal Information PW and RHL	7	13.1 Layout Guidelines	16
8.6 Electrical Characteristics	8	13.2 Layout Example	16
8.7 Switching Characteristics, $V_{CCA} = 1.8\text{ V} \pm 0.15\text{ V}$...	9	14 Device and Documentation Support	17
8.8 Switching Characteristics, $V_{CCA} = 2.5\text{ V} \pm 0.2\text{ V}$	9	14.1 Trademarks	17
8.9 Switching Characteristics, $V_{CCA} = 3.3\text{ V} \pm 0.3\text{ V}$...	10	14.2 Electrostatic Discharge Caution	17
8.10 Switching Characteristics, $V_{CCA} = 5\text{ V} \pm 0.5\text{ V}$	10	14.3 Glossary	17
8.11 Operating Characteristics	10	15 Mechanical, Packaging, and Orderable Information	17

5 Revision History

NOTE: Page numbers for previous revisions may differ from page numbers in the current version.

Changes from Revision A (June 2005) to Revision B	Page
<ul style="list-style-type: none"> Added the list of Application, Pin Functions table, Handling Rating table, Feature Description section, Device Functional Modes, Application and Implementation section, Power Supply Recommendations section, Layout section, Device and Documentation Support section, and Mechanical, Packaging, and Orderable Information section. 	1
<ul style="list-style-type: none"> Changed Feature From: 200-V Machine Model (A115-A) To: 100-V Machine Model (A115-A) 	1

Changes from Original (June 2005) to Revision A	Page
<ul style="list-style-type: none"> Changed the device From: Product Preview To: Production 	1

6 Description (continued)

This device is fully specified for partial-power-down applications using I_{off} . The I_{off} circuitry disables the outputs, preventing damaging current backflow through the device when it is powered down.

The V_{CC} isolation feature ensures that if either V_{CC} input is at GND, all outputs are in the high-impedance state.

To ensure the high-impedance state during power up or power down, \overline{OE} should be tied to V_{CC} through a pullup resistor; the minimum value of the resistor is determined by the current-sinking capability of the driver.

7 Pin Configuration and Functions

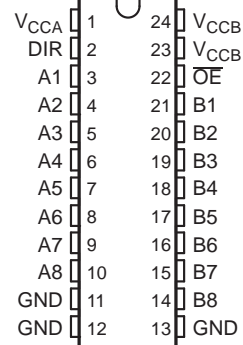
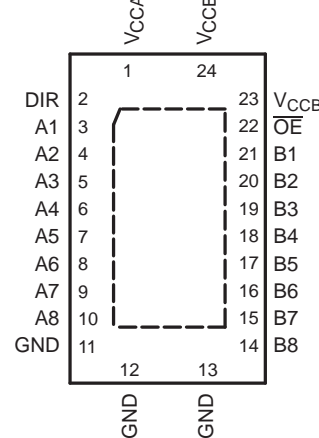
**DB, DBQ, DGV, OR PW PACKAGE
(TOP VIEW)**

**RHL PACKAGE
(TOP VIEW)**

Pin Functions

PIN		I/O	DESCRIPTION
NAME	NO.		
A1	3	I/O	Input/output A1. Referenced to V_{CCA} .
A2	4	I/O	Input/output A2. Referenced to V_{CCA} .
A3	5	I/O	Input/output A3. Referenced to V_{CCA} .
A4	6	I/O	Input/output A4. Referenced to V_{CCA} .
A5	7	I/O	Input/output A5. Referenced to V_{CCA} .
A6	8	I/O	Input/output A6. Referenced to V_{CCA} .
A7	9	I/O	Input/output A7. Referenced to V_{CCA} .
A8	10	I/O	Input/output A8. Referenced to V_{CCA} .
B1	21	I/O	Input/output B1. Referenced to V_{CCB} .
B2	20	I/O	Input/output B2. Referenced to V_{CCB} .
B3	19	I/O	Input/output B3. Referenced to V_{CCB} .
B4	18	I/O	Input/output B4. Referenced to V_{CCB} .
B5	17	I/O	Input/output B5. Referenced to V_{CCB} .
B6	16	I/O	Input/output B6. Referenced to V_{CCB} .
B7	15	I/O	Input/output B7. Referenced to V_{CCB} .
B8	14	I/O	Input/output B8. Referenced to V_{CCB} .
DIR	2	I	Direction-control signal.
GND	11, 12, 13	G	Ground
\overline{OE}	22	I	3-state output-mode enables. Pull \overline{OE} high to place all outputs in 3-state mode. Referenced to V_{CCA} .
V_{CCA}	1	P	A-port supply voltage. $1.65\text{ V} \leq V_{CCA} \leq 5.5\text{ V}$
V_{CCB}	23, 24	P	B-port supply voltage. $1.65\text{ V} \leq V_{CCB} \leq 5.5\text{ V}$

8 Specifications

8.1 Absolute Maximum Ratings⁽¹⁾

over operating free-air temperature range (unless otherwise noted)

		MIN	MAX	UNIT	
Supply voltage range, V_{CCA} , V_{CCB}		-0.5	6.5	V	
V_I	Input voltage range ⁽²⁾	I/O ports (A port)	-0.5	6.5	V
		I/O ports (B port)	-0.5	6.5	
		Control inputs	-0.5	6.5	
V_O	Voltage range applied to any output in the high-impedance or power-off state ⁽²⁾	A port	-0.5	6.5	V
		B port	-0.5	6.5	
V_O	Voltage range applied to any output in the high or low state ^{(2) (3)}	A port	-0.5	$V_{CCA} + 0.5$	V
		B port	-0.5	$V_{CCB} + 0.5$	
I_{IK}	Input clamp current	$V_I < 0$	-50	mA	
I_{OK}	Output clamp current	$V_O < 0$	-50	mA	
I_O	Continuous output current		±50	mA	
Continuous current through each V_{CCA} , V_{CCB} , and GND			±100	mA	

- (1) Stresses beyond those listed under "absolute maximum ratings" may cause permanent damage to the device. These are stress ratings only, and functional operation of the device at these or any other conditions beyond those indicated under "recommended operating conditions" is not implied. Exposure to absolute-maximum-rated conditions for extended periods may affect device reliability.
- (2) The input and output negative-voltage ratings may be exceeded if the input and output current ratings are observed.
- (3) The output positive-voltage rating may be exceeded up to 6.5 V maximum if the output current rating is observed.

8.2 Handling Ratings

		MIN	MAX	UNIT	
T_{stg}	Storage temperature range	-65	150	°C	
$V_{(ESD)}$	Electrostatic discharge	Human body model (HBM), per ANSI/ESDA/JEDEC JS-001, all pins ⁽¹⁾	-4000	4000	V
		Charged device model (CDM), per JEDEC specification JESD22-C101, all pins ⁽²⁾	-1000	1000	

- (1) JEDEC document JEP155 states that 500-V HBM allows safe manufacturing with a standard ESD control process.
- (2) JEDEC document JEP157 states that 250-V CDM allows safe manufacturing with a standard ESD control process.

8.3 Recommended Operating Conditions^{(1) (2) (3) (4)}

			V_{CCI}	V_{CCO}	MIN	MAX	UNIT
V_{CCA}	Supply voltage				1.65	5.5	V
V_{CCB}					1.65	5.5	
V_{IH}	High-level input voltage	Data inputs ⁽⁵⁾	1.65 V to 1.95 V		$V_{CCI} \times 0.65$		V
			2.3 V to 2.7 V		1.7		
			3 V to 3.6 V		2		
			4.5 V to 5.5 V		$V_{CCI} \times 0.7$		
V_{IL}	Low-level input voltage	Data inputs ⁽⁵⁾	1.65 V to 1.95 V			$V_{CCI} \times 0.35$	V
			2.3 V to 2.7 V			0.7	
			3 V to 3.6 V			0.8	
			4.5 V to 5.5 V			$V_{CCI} \times 0.3$	
V_{IH}	High-level input voltage	Control inputs (referenced to V_{CCA}) ⁽⁶⁾	1.65 V to 1.95 V		$V_{CCA} \times 0.65$		V
			2.3 V to 2.7 V		1.7		
			3 V to 3.6 V		2		
			4.5 V to 5.5 V		$V_{CCA} \times 0.7$		
V_{IL}	Low-level input voltage	Control inputs (referenced to V_{CCA}) ⁽⁶⁾	1.65 V to 1.95 V			$V_{CCA} \times 0.35$	V
			2.3 V to 2.7 V			0.7	
			3 V to 3.6 V			0.8	
			4.5 V to 5.5 V			$V_{CCA} \times 0.3$	
V_I	Input voltage	Control inputs			0	5.5	V
V_{IO}	Input/output voltage	Active state			0	V_{CCO}	V
		3-State			0	5.5	V
I_{OH}	High-level output current		1.65 V to 1.95 V			-4	mA
			2.3 V to 2.7 V			-8	
			3 V to 3.6 V			-24	
			4.5 V to 5.5 V			-32	
I_{OL}	Low-level output current		1.65 V to 1.95 V			4	mA
			2.3 V to 2.7 V			8	
			3 V to 3.6 V			24	
			4.5 V to 5.5 V			32	
$\Delta t/\Delta v$	Input transition rise or fall rate	Data inputs	1.65 V to 1.95 V			20	ns/V
			2.3 V to 2.7 V			20	
			3 V to 3.6 V			10	
			4.5 V to 5.5 V			5	
T_A	Operating free-air temperature				-40	85	°C

(1) V_{CCI} is the V_{CC} associated with the data input port.

(2) V_{CCO} is the V_{CC} associated with the output port.

(3) All unused or driven (floating) data inputs (I/Os) of the device must be held at logic HIGH or LOW (preferably V_{CCI} or GND) to ensure proper device operation and minimize power. Refer to the TI application report, *Implications of Slow or Floating CMOS Inputs*, literature number SCBA004.

(4) All unused control inputs must be held at V_{CCA} or GND to ensure proper device operation and minimize power consumption.

(5) For V_{CCI} values not specified in the data sheet, $V_{IH \text{ min}} = V_{CCI} \times 0.7 \text{ V}$, $V_{IL \text{ max}} = V_{CCI} \times 0.3 \text{ V}$.

(6) For V_{CCA} values not specified in the data sheet, $V_{IH \text{ min}} = V_{CCA} \times 0.7 \text{ V}$, $V_{IL \text{ max}} = V_{CCA} \times 0.3 \text{ V}$.

8.4 Thermal Information DB, DBQ and DGV

THERMAL METRIC ⁽¹⁾		DB	DBQ	DGV	UNIT
		24 PINS	24 PINS	24 PINS	
$R_{\theta JA}$	Junction-to-ambient thermal resistance	88.5	81.2	91.1	°C/W
$R_{\theta JC(top)}$	Junction-to-case (top) thermal resistance	48.7	44.8	23.7	
$R_{\theta JB}$	Junction-to-board thermal resistance	44.1	34.5	44.5	
Ψ_{JT}	Junction-to-top characterization parameter	12.8	9.5	0.6	
Ψ_{JB}	Junction-to-board characterization parameter	43.6	37.2	44.1	
$R_{\theta JC(bot)}$	Junction-to-case (bottom) thermal resistance	N/A	N/A	N/A	

(1) For more information about traditional and new thermal metrics, see the *IC Package Thermal Metrics* application report, [SPRA953](#).

8.5 Thermal Information PW and RHL

THERMAL METRIC ⁽¹⁾		PW	RHL	UNIT
		24 PINS	24 PINS	
$R_{\theta JA}$	Junction-to-ambient thermal resistance	90.6	37.4	°C/W
$R_{\theta JC(top)}$	Junction-to-case (top) thermal resistance	27.6	38.1	
$R_{\theta JB}$	Junction-to-board thermal resistance	45.3	15.2	
Ψ_{JT}	Junction-to-top characterization parameter	1.3	0.7	
Ψ_{JB}	Junction-to-board characterization parameter	44.8	15.2	
$R_{\theta JC(bot)}$	Junction-to-case (bottom) thermal resistance	N/A	4.3	

(1) For more information about traditional and new thermal metrics, see the *IC Package Thermal Metrics* application report, [SPRA953](#).

8.6 Electrical Characteristics^{(1) (2)}

over recommended operating free-air temperature range (unless otherwise noted)

PARAMETER		TEST CONDITIONS	V _{CCA}	V _{CCB}	MIN	TYP	MAX	MIN	MAX	UNIT
V _{OH}		I _{OH} = -100 μA, V _I = V _{IH}	1.65 V to 4.5 V	1.65 V to 4.5 V				V _{CCO} - 0.1		V
		I _{OH} = -4 mA, V _I = V _{IH}	1.65 V	1.65 V				1.2		
		I _{OH} = -8 mA, V _I = V _{IH}	2.3 V	2.3 V				1.9		
		I _{OH} = -24 mA, V _I = V _{IH}	3 V	3 V				2.4		
		I _{OH} = -32 mA, V _I = V _{IH}	4.5 V	4.5 V				3.8		
V _{OL}		I _{OL} = 100 μA, V _I = V _{IL}	1.65 V to 4.5 V	1.65 V to 4.5 V				0.1		V
		I _{OL} = 4 mA, V _I = V _{IL}	1.65 V	1.65 V				0.45		
		I _{OL} = 8 mA, V _I = V _{IL}	2.3 V	2.3 V				0.3		
		I _{OL} = 24 mA, V _I = V _{IL}	3 V	3 V				0.55		
		I _{OL} = 32 mA, V _I = V _{IL}	4.5 V	4.5 V				0.55		
I _I	DIR	V _I = V _{CCA} or GND	1.65 V to 5.5 V	1.65 V to 5.5 V				±1	±2	μA
I _{off}	A or B port	V _I or V _O = 0 to 5.5 V	0 V	0 to 5.5 V				±1	±2	μA
			0 to 5.5 V	0 V				±1	±2	
I _{OZ}	A or B port	V _O = V _{CCO} or GND, OE = V _{IH}	1.65 V to 5.5 V	1.65 V to 5.5 V				±1	±2	μA
I _{CCA}		V _I = V _{CCI} or GND, I _O = 0	1.65 V to 5.5 V	1.65 V to 5.5 V					15	μA
			5 V	0 V					15	
			0 V	5 V					-2	
I _{CCB}		V _I = V _{CCI} or GND, I _O = 0	1.65 V to 5.5 V	1.65 V to 5.5 V					15	μA
			5 V	0 V					-2	
			0 V	5 V					15	
I _{CCA} + I _{CCB}		V _I = V _{CCI} or GND, I _O = 0	1.65 V to 5.5 V	1.65 V to 5.5 V					25	μA
ΔI _{CCA}	A port	One A port at V _{CCA} - 0.6 V, DIR at V _{CCA} , B port = open	3 V to 5.5 V	3 V to 5.5 V					50	μA
	DIR	DIR at V _{CCA} - 0.6 V, B port = open, A port at V _{CCA} or GND							50	
ΔI _{CCB}	B port	One B port at V _{CCB} - 0.6 V, DIR at GND, A port = open	3 V to 5.5 V	3 V to 5.5 V					50	μA
C _i	Control inputs	V _I = V _{CCA} or GND	3.3 V	3.3 V		4			5	pF
C _{io}	A or B port	V _O = V _{CCA/B} or GND	3.3 V	3.3 V		8.5			10	pF

 (1) V_{CCO} is the V_{CC} associated with the output port.

 (2) V_{CCI} is the V_{CC} associated with the input port.

8.7 Switching Characteristics, $V_{CCA} = 1.8\text{ V} \pm 0.15\text{ V}$

over recommended operating free-air temperature range, $V_{CCA} = 1.8\text{ V} \pm 0.15\text{ V}$ (unless otherwise noted) (see [Figure 3](#))

PARAMETER	FROM (INPUT)	TO (OUTPUT)	$V_{CCB} = 1.8\text{ V} \pm 0.15\text{ V}$		$V_{CCB} = 2.5\text{ V} \pm 0.2\text{ V}$		$V_{CCB} = 3.3\text{ V} \pm 0.3\text{ V}$		$V_{CCB} = 5\text{ V} \pm 0.5\text{ V}$		UNIT
			MIN	MAX	MIN	MAX	MIN	MAX	MIN	MAX	
t_{PLH}	A	B	1.7	21.9	1.3	9.2	1	7.4	0.8	7.1	ns
t_{PHL}											
t_{PLH}	B	A	0.9	23.8	0.8	23.6	0.7	23.4	0.7	23.4	ns
t_{PHL}											
t_{PHZ}	\overline{OE}	A	1.5	29.6	1.5	29.4	1.5	29.3	1.4	29.2	ns
t_{PLZ}											
t_{PHZ}	\overline{OE}	B	2.4	32.2	1.9	13.1	1.7	12	1.3	10.3	ns
t_{PLZ}											
t_{PZH}	\overline{OE}	A	0.4	24	0.4	23.8	0.4	23.7	0.4	23.7	ns
t_{PZL}											
t_{PZH}	\overline{OE}	B	1.8	32	1.5	16	1.2	12.6	0.9	10.8	ns
t_{PZL}											

8.8 Switching Characteristics, $V_{CCA} = 2.5\text{ V} \pm 0.2\text{ V}$

over recommended operating free-air temperature range, $V_{CCA} = 2.5\text{ V} \pm 0.2\text{ V}$ (unless otherwise noted) (see [Figure 3](#))

PARAMETER	FROM (INPUT)	TO (OUTPUT)	$V_{CCB} = 1.8\text{ V} \pm 0.15\text{ V}$		$V_{CCB} = 2.5\text{ V} \pm 0.2\text{ V}$		$V_{CCB} = 3.3\text{ V} \pm 0.3\text{ V}$		$V_{CCB} = 5\text{ V} \pm 0.5\text{ V}$		UNIT
			MIN	MAX	MIN	MAX	MIN	MAX	MIN	MAX	
t_{PLH}	A	B	1.5	21.4	1.2	9	0.8	6.2	0.6	4.8	ns
t_{PHL}											
t_{PLH}	B	A	1.2	9.3	1	9.1	1	8.9	0.9	8.8	ns
t_{PHL}											
t_{PHZ}	\overline{OE}	A	1.4	9	1.4	9	1.4	9	1.4	9	ns
t_{PLZ}											
t_{PHZ}	\overline{OE}	B	2.3	29.6	1.8	11	1.7	9.3	0.9	6.9	ns
t_{PLZ}											
t_{PZH}	\overline{OE}	A	1	10.9	1	10.9	1	10.9	1	10.9	ns
t_{PZL}											
t_{PZH}	\overline{OE}	B	1.7	28.2	1.5	12.9	1.2	9.4	1	6.9	ns
t_{PZL}											

8.9 Switching Characteristics, $V_{CCA} = 3.3 \text{ V} \pm 0.3 \text{ V}$

 over recommended operating free-air temperature range, $V_{CCA} = 3.3 \text{ V} \pm 0.3 \text{ V}$ (unless otherwise noted) (see [Figure 3](#))

PARAMETER	FROM (INPUT)	TO (OUTPUT)	$V_{CCB} = 1.8 \text{ V} \pm 0.15 \text{ V}$		$V_{CCB} = 2.5 \text{ V} \pm 0.2 \text{ V}$		$V_{CCB} = 3.3 \text{ V} \pm 0.3 \text{ V}$		$V_{CCB} = 5 \text{ V} \pm 0.5 \text{ V}$		UNIT
			MIN	MAX	MIN	MAX	MIN	MAX	MIN	MAX	
t_{PLH}	A	B	1.5	21.2	1.1	8.8	0.8	6.3	0.5	4.4	ns
t_{PHL}											
t_{PLH}	B	A	0.8	7.2	0.8	6.2	0.7	6.1	0.6	6	ns
t_{PHL}											
t_{PHZ}	\overline{OE}	A	1.6	8.2	1.6	8.2	1.6	8.2	1.6	8.2	ns
t_{PLZ}											
t_{PHZ}	\overline{OE}	B	2.1	29	1.7	10.3	1.5	8.6	0.8	6.3	ns
t_{PLZ}											
t_{PZH}	\overline{OE}	A	0.8	8.1	0.8	8.1	0.8	8.1	0.8	8.1	ns
t_{PZL}											
t_{PZH}	\overline{OE}	B	1.8	27.7	1.4	12.4	1.1	8.5	0.9	6.4	ns
t_{PZL}											

8.10 Switching Characteristics, $V_{CCA} = 5 \text{ V} \pm 0.5 \text{ V}$

 over recommended operating free-air temperature range, $V_{CCA} = 5 \text{ V} \pm 0.5 \text{ V}$ (unless otherwise noted) (see [Figure 3](#))

PARAMETER	FROM (INPUT)	TO (OUTPUT)	$V_{CC} = 1.8 \text{ V} \pm 0.15 \text{ V}$		$V_{CC} = 2.5 \text{ V} \pm 0.2 \text{ V}$		$V_{CC} = 3.3 \text{ V} \pm 0.3 \text{ V}$		$V_{CC} = 5 \text{ V} \pm 0.5 \text{ V}$		UNIT
			MIN	MAX	MIN	MAX	MIN	MAX	MIN	MAX	
t_{PLH}	A	B	1.5	21.4	1	8.8	0.7	6	0.4	4.2	ns
t_{PHL}											
t_{PLH}	B	A	0.7	7	0.4	4.8	0.3	4.5	0.3	4.3	ns
t_{PHL}											
t_{PHZ}	\overline{OE}	A	0.3	5.4	0.3	5.4	0.3	5.4	0.3	5.4	ns
t_{PLZ}											
t_{PHZ}	\overline{OE}	B	2	28.7	1.6	9.7	1.4	8	0.7	5.7	ns
t_{PLZ}											
t_{PZH}	\overline{OE}	A	0.7	6.4	0.7	6.4	0.7	6.4	0.7	6.4	ns
t_{PZL}											
t_{PZH}	\overline{OE}	B	1.5	27.6	1.3	11.4	1	8.1	0.9	6	ns
t_{PZL}											

8.11 Operating Characteristics

 $T_A = 25^\circ\text{C}$

PARAMETER	TEST CONDITIONS	$V_{CCA} = V_{CCB} = 1.8 \text{ V}$	$V_{CCA} = V_{CCB} = 2.5 \text{ V}$	$V_{CCA} = V_{CCB} = 3.3 \text{ V}$	$V_{CCA} = V_{CCB} = 5 \text{ V}$	UNIT
		TYP	TYP	TYP	TYP	
C_{pdA} (1)	A-port input, B-port output	2	2	2	3	pF
	B-port input, A-port output	12	13	13	16	
C_{pdB} (1)	A-port input, B-port output	13	13	14	16	
	B-port input, A-port output	2	2	2	3	

(1) Power dissipation capacitance per transceiver

8.12 Typical Characteristics

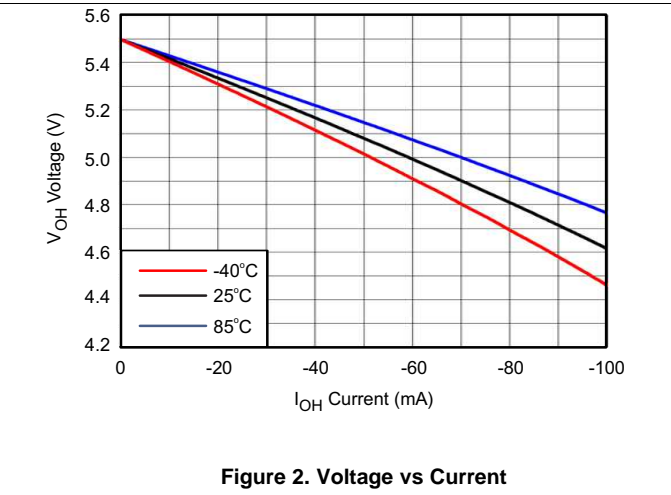
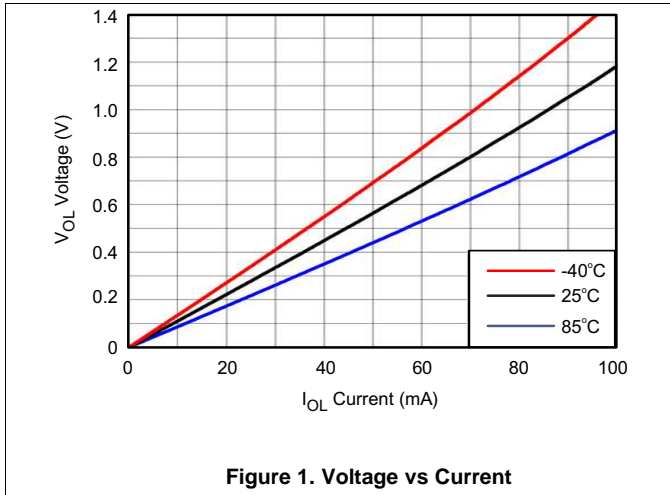

9 Parameter Measurement Information

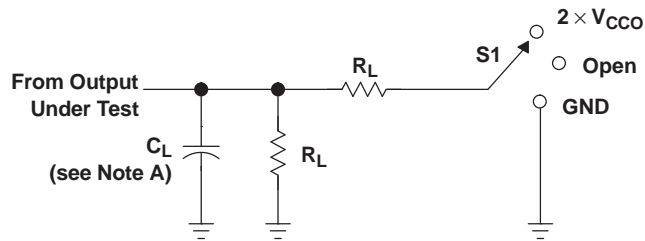
LOAD CIRCUIT

V_{CCO}	C_L	R_L	V_{TP}
$1.8 \text{ V} \pm 0.15 \text{ V}$	15 pF	2 k Ω	0.15 V
$2.5 \text{ V} \pm 0.2 \text{ V}$	15 pF	2 k Ω	0.15 V
$3.3 \text{ V} \pm 0.3 \text{ V}$	15 pF	2 k Ω	0.3 V
$5 \text{ V} \pm 0.5 \text{ V}$	15 pF	2 k Ω	0.3 V

TEST	S1
t_{pd}	Open
t_{PLZ}/t_{PZL}	$2 \times V_{CCO}$
t_{PHZ}/t_{PZH}	GND

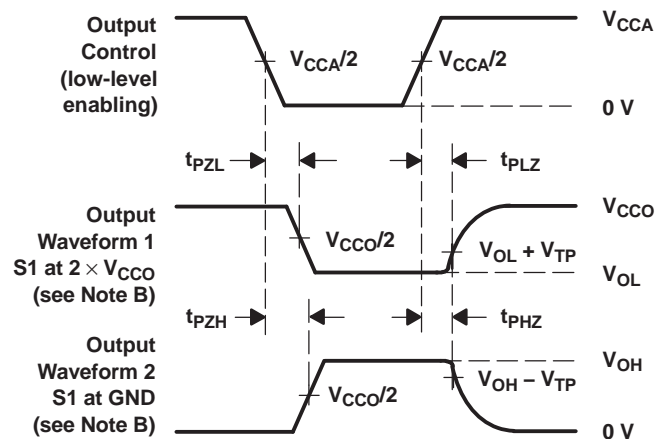
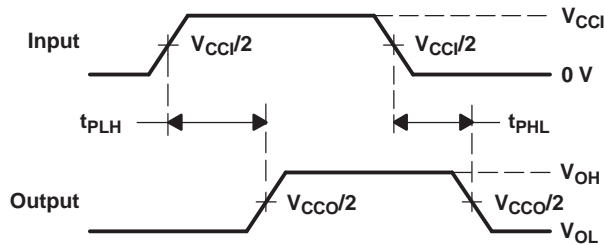
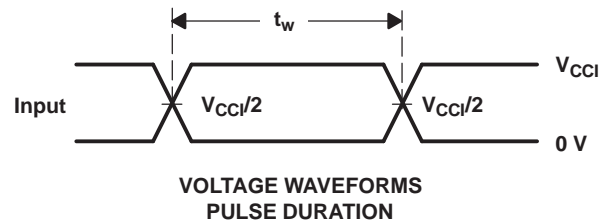

- NOTES:
- C_L includes probe and jig capacitance.
 - Waveform 1 is for an output with internal conditions such that the output is low, except when disabled by the output control. Waveform 2 is for an output with internal conditions such that the output is high, except when disabled by the output control.
 - All input pulses are supplied by generators having the following characteristics: PRR \leq 10 MHz, $Z_O = 50 \Omega$, $dv/dt \geq 1 \text{ V/ns}$.
 - The outputs are measured one at a time, with one transition per measurement.
 - t_{PLZ} and t_{PHZ} are the same as t_{dis} .
 - t_{PZL} and t_{PZH} are the same as t_{en} .
 - t_{PLH} and t_{PHL} are the same as t_{pd} .
 - V_{CCI} is the V_{CC} associated with the input port.
 - V_{CCO} is the V_{CC} associated with the output port.
 - All parameters and waveforms are not applicable to all devices.

Figure 3. Load Circuit and Voltage Waveforms

10 Detailed Description

10.1 Overview

The SN74LVC8T245 is an 8-bit, dual supply non-inverting voltage level translation. Pin Ax and direction control pin are support by V_{CCA} and pin Bx is support by V_{CCB} . The A port is able to accept I/O voltages ranging from 1.65 V to 5.5 V, while the B port can accept I/O voltages from 1.65 V to 5.5 V. The high on DIR allows data transmission from A to B and a low on DIR allows data transmission from B to A.

10.2 Functional Block Diagram

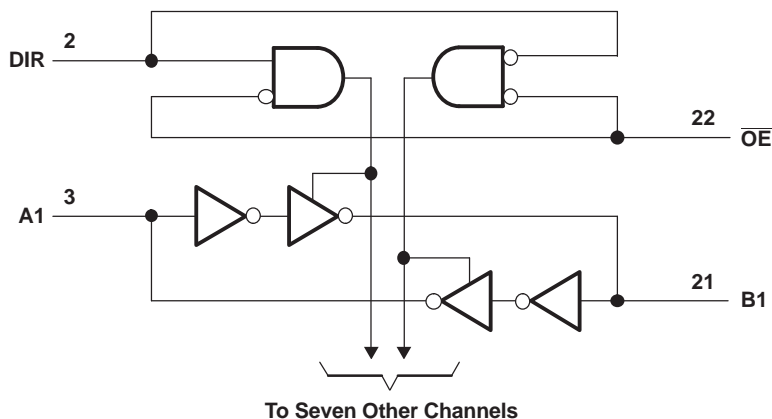

Figure 4. Logic Diagram (Positive Logic)

10.3 Feature Description

10.3.1 Fully Configurable Dual-Rail Design Allows Each Port to Operate Over the Full 1.65-V to 5.5-V Power-Supply Range

Both V_{CCA} and V_{CCB} can be supplied at any voltage between 1.65 V and 5.5 V making the device suitable for translating between any of the voltage nodes (1.8 V, 2.5 V, 3.3 V and 5 V).

10.3.2 I_{off} Supports Partial-Power-Down Mode Operation

I_{off} prevents backflow current by disabling I/O output circuits when device is in partial-power-down mode.

10.4 Device Functional Modes

The SN74LVC8T245 is voltage level translator that can operate from 1.65 V to 5.5 V (V_{CCA}) and 1.65 V to 5.5 V (V_{CCB}). The signal translation between 1.65 V and 5.5 V requires direction control and output enable control. When \overline{OE} is low and DIR is high, data transmission is from A to B. When \overline{OE} is low and DIR is low, data transmission is from B to A. When \overline{OE} is high, both output ports will be high-impedance.

Table 1. Function Table⁽¹⁾
(Each 8-Bit Section)

CONTROL INPUTS		OUTPUT CIRCUITS		OPERATION
\overline{OE}	DIR	A PORT	B PORT	
L	L	Enabled	Hi-Z	B data to A bus
L	H	Hi-Z	Enabled	A data to B bus
H	X	Hi-Z	Hi-Z	Isolation

(1) Input circuits of the data I/Os are always active.

11 Application and Implementation

NOTE

Information in the following applications sections is not part of the TI component specification, and TI does not warrant its accuracy or completeness. TI's customers are responsible for determining suitability of components for their purposes. Customers should validate and test their design implementation to confirm system functionality.

11.1 Application Information

The SN74LVC8T245 device can be used in level-translation applications for interfacing devices or systems operating at different interface voltages with one another. The maximum output current can be up to 32 mA when device is powered by 5 V.

11.2 Typical Application

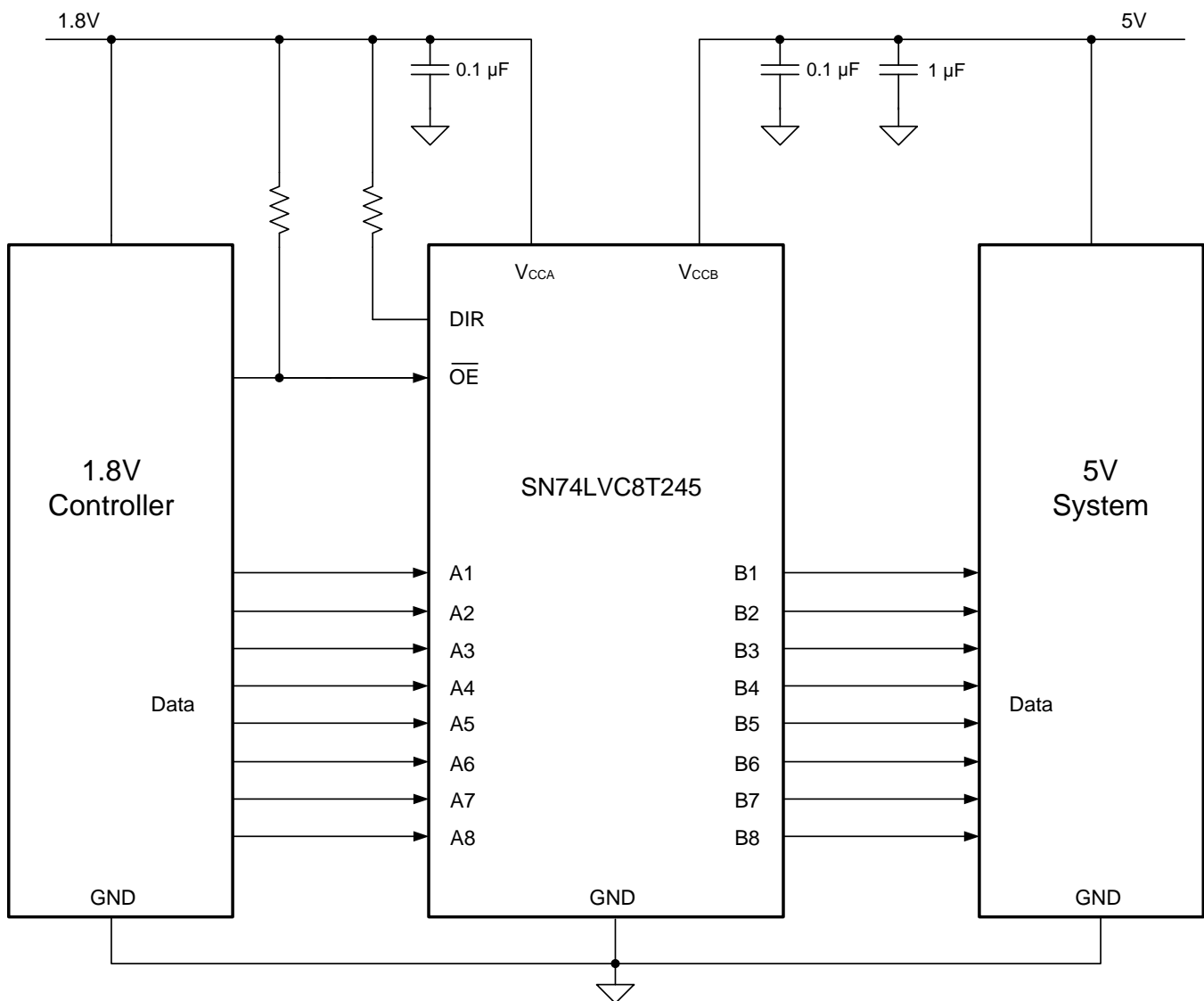

Figure 5. Typical Application Circuit

Typical Application (continued)

11.2.1 Design Requirements

For this design example, use the parameters listed in [Table 2](#).

Table 2. Design Parameters

PARAMETERS	VALUES
Input voltage range	1.65 V to 5.5 V
Output voltage	1.65 V to 5.5 V

11.2.2 Detailed Design Procedure

To begin the design process, determine the following:

- Input voltage range
 - Use the supply voltage of the device that is driving the SN74LVC8T245 device to determine the input voltage range. For a valid logic high, the value must exceed the V_{IH} of the input port. For a valid logic low, the value must be less than the V_{IL} of the input port.
- Output voltage range
 - Use the supply voltage of the device that the SN74LVC8T245 device is driving to determine the output voltage range.

11.2.3 Application Curve

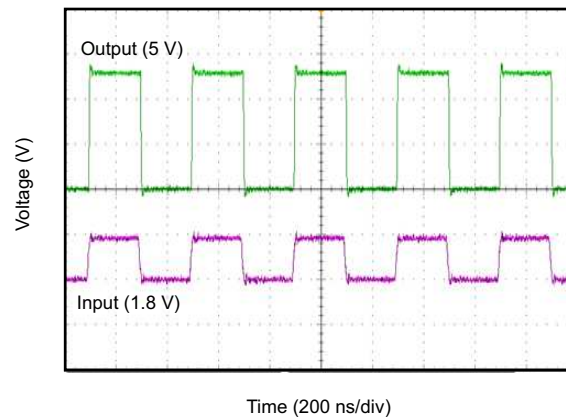

Figure 6. Translation Up (1.8 V to 5 V) at 2.5 MHz

12 Power Supply Recommendations

The SN74LVC8T245 device uses two separate configurable power-supply rails, V_{CCA} and V_{CCB} . V_{CCA} accepts any supply voltage from 1.65 V to 5.5 V and V_{CCB} accepts any supply voltage from 1.65 V to 5.5 V. The A port and B port are designed to track V_{CCA} and V_{CCB} respectively allowing for low-voltage bidirectional translation between any of the 1.8-V, 2.5 -V, 3.3-V and 5-V voltage nodes.

13 Layout

13.1 Layout Guidelines

To ensure reliability of the device, following common printed-circuit board layout guidelines is recommended.

- Bypass capacitors should be used on power supplies.
- Short trace lengths should be used to avoid excessive loading.
- Placing pads on the signal paths for loading capacitors or pullup resistors helps adjust rise and fall times of signals depending on the system requirements.

13.2 Layout Example

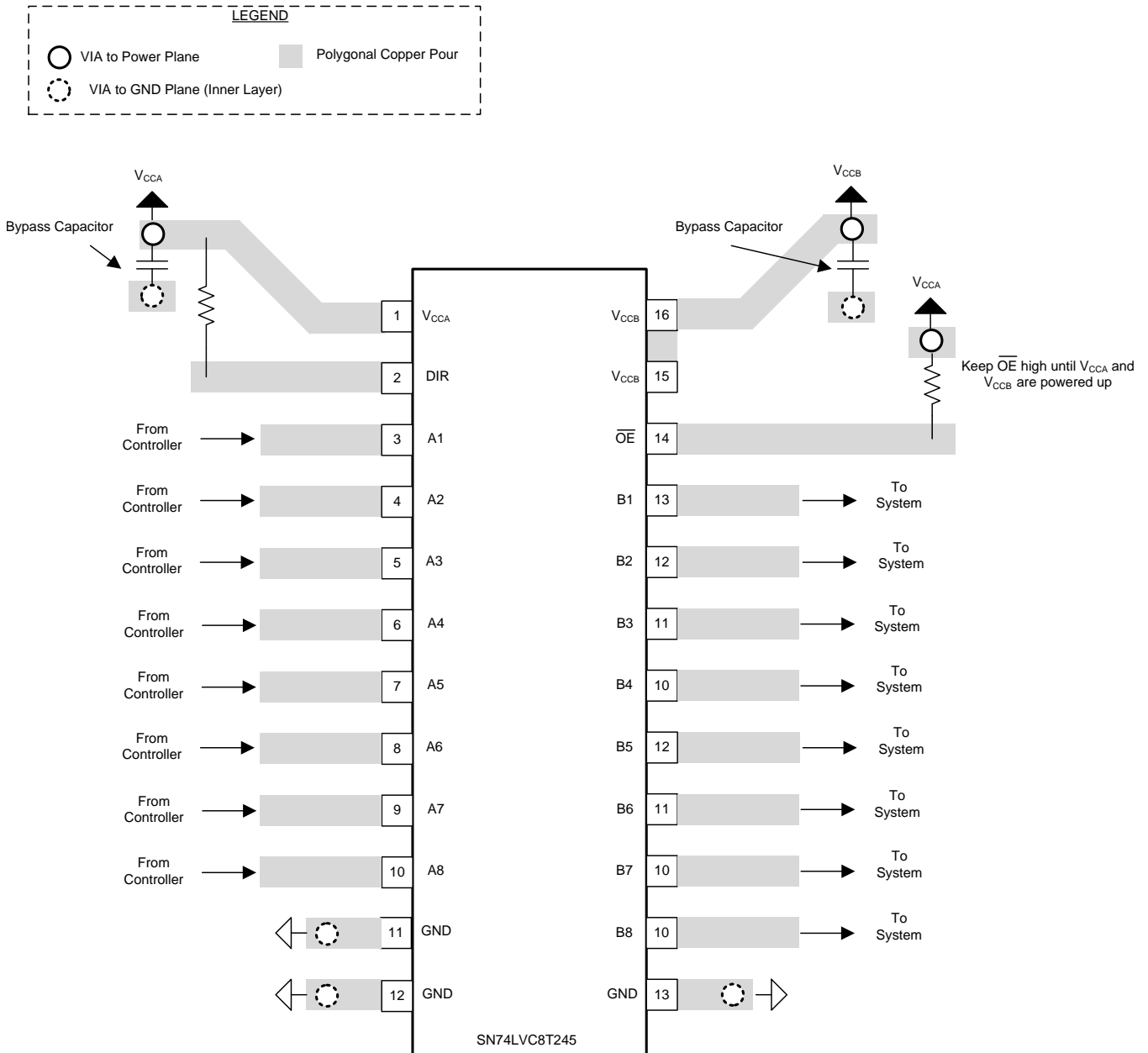

Figure 7. SN74LVC8T245 Layout

14 Device and Documentation Support

14.1 Trademarks

All trademarks are the property of their respective owners.

14.2 Electrostatic Discharge Caution



These devices have limited built-in ESD protection. The leads should be shorted together or the device placed in conductive foam during storage or handling to prevent electrostatic damage to the MOS gates.

14.3 Glossary

[SLYZ022](#) — *TI Glossary*.

This glossary lists and explains terms, acronyms, and definitions.

15 Mechanical, Packaging, and Orderable Information

The following pages include mechanical packaging and orderable information. This information is the most current data available for the designated devices. This data is subject to change without notice and revision of this document. For browser-based versions of this data sheet, refer to the left-hand navigation.

PACKAGING INFORMATION

Orderable Device	Status (1)	Package Type	Package Drawing	Pins	Package Qty	Eco Plan (2)	Lead finish/ Ball material (6)	MSL Peak Temp (3)	Op Temp (°C)	Device Marking (4/5)	Samples
74LVC8T245DBQRG4	ACTIVE	SSOP	DBQ	24	2500	RoHS & Green	NIPDAU	Level-2-260C-1 YEAR	-40 to 85	LVC8T245	Samples
74LVC8T245RHLRG4	ACTIVE	VQFN	RHL	24	1000	RoHS & Green	NIPDAU	Level-2-260C-1 YEAR	-40 to 85	NH245	Samples
SN74LVC8T245DBQR	ACTIVE	SSOP	DBQ	24	2500	RoHS & Green	NIPDAU	Level-2-260C-1 YEAR	-40 to 85	LVC8T245	Samples
SN74LVC8T245DBR	ACTIVE	SSOP	DB	24	2000	RoHS & Green	NIPDAU	Level-1-260C-UNLIM	-40 to 85	NH245	Samples
SN74LVC8T245DBRG4	ACTIVE	SSOP	DB	24	2000	RoHS & Green	NIPDAU	Level-1-260C-UNLIM	-40 to 85	NH245	Samples
SN74LVC8T245DGVR	ACTIVE	TVSOP	DGV	24	2000	RoHS & Green	NIPDAU	Level-1-260C-UNLIM	-40 to 85	NH245	Samples
SN74LVC8T245DGVRG4	ACTIVE	TVSOP	DGV	24	2000	RoHS & Green	NIPDAU	Level-1-260C-UNLIM	-40 to 85	NH245	Samples
SN74LVC8T245DWR	ACTIVE	SOIC	DW	24	2000	RoHS & Green	NIPDAU	Level-1-260C-UNLIM	-40 to 85	LVC8T245	Samples
SN74LVC8T245DWRG4	ACTIVE	SOIC	DW	24	2000	RoHS & Green	NIPDAU	Level-1-260C-UNLIM	-40 to 85	LVC8T245	Samples
SN74LVC8T245NSR	ACTIVE	SO	NS	24	2000	RoHS & Green	NIPDAU	Level-1-260C-UNLIM	-40 to 85	LVC8T245	Samples
SN74LVC8T245PW	ACTIVE	TSSOP	PW	24	60	RoHS & Green	NIPDAU	Level-1-260C-UNLIM	-40 to 85	NH245	Samples
SN74LVC8T245PWG4	ACTIVE	TSSOP	PW	24	60	RoHS & Green	NIPDAU	Level-1-260C-UNLIM	-40 to 85	NH245	Samples
SN74LVC8T245PWR	ACTIVE	TSSOP	PW	24	2000	RoHS & Green	NIPDAU	Level-1-260C-UNLIM	-40 to 85	NH245	Samples
SN74LVC8T245PWRE4	ACTIVE	TSSOP	PW	24	2000	RoHS & Green	NIPDAU	Level-1-260C-UNLIM	-40 to 85	NH245	Samples
SN74LVC8T245PWRG4	ACTIVE	TSSOP	PW	24	2000	RoHS & Green	NIPDAU	Level-1-260C-UNLIM	-40 to 85	NH245	Samples
SN74LVC8T245RHLR	ACTIVE	VQFN	RHL	24	1000	RoHS & Green	NIPDAU	Level-2-260C-1 YEAR	-40 to 85	NH245	Samples

(1) The marketing status values are defined as follows:

ACTIVE: Product device recommended for new designs.

LIFEBUY: TI has announced that the device will be discontinued, and a lifetime-buy period is in effect.

NRND: Not recommended for new designs. Device is in production to support existing customers, but TI does not recommend using this part in a new design.

PREVIEW: Device has been announced but is not in production. Samples may or may not be available.

OBSOLETE: TI has discontinued the production of the device.

(2) **RoHS:** TI defines "RoHS" to mean semiconductor products that are compliant with the current EU RoHS requirements for all 10 RoHS substances, including the requirement that RoHS substance do not exceed 0.1% by weight in homogeneous materials. Where designed to be soldered at high temperatures, "RoHS" products are suitable for use in specified lead-free processes. TI may reference these types of products as "Pb-Free".

RoHS Exempt: TI defines "RoHS Exempt" to mean products that contain lead but are compliant with EU RoHS pursuant to a specific EU RoHS exemption.

Green: TI defines "Green" to mean the content of Chlorine (Cl) and Bromine (Br) based flame retardants meet JS709B low halogen requirements of ≤ 1000 ppm threshold. Antimony trioxide based flame retardants must also meet the ≤ 1000 ppm threshold requirement.

(3) **MSL, Peak Temp.** - The Moisture Sensitivity Level rating according to the JEDEC industry standard classifications, and peak solder temperature.

(4) There may be additional marking, which relates to the logo, the lot trace code information, or the environmental category on the device.

(5) Multiple Device Markings will be inside parentheses. Only one Device Marking contained in parentheses and separated by a "~" will appear on a device. If a line is indented then it is a continuation of the previous line and the two combined represent the entire Device Marking for that device.

(6) **Lead finish/Ball material** - Orderable Devices may have multiple material finish options. Finish options are separated by a vertical ruled line. Lead finish/Ball material values may wrap to two lines if the finish value exceeds the maximum column width.

Important Information and Disclaimer: The information provided on this page represents TI's knowledge and belief as of the date that it is provided. TI bases its knowledge and belief on information provided by third parties, and makes no representation or warranty as to the accuracy of such information. Efforts are underway to better integrate information from third parties. TI has taken and continues to take reasonable steps to provide representative and accurate information but may not have conducted destructive testing or chemical analysis on incoming materials and chemicals. TI and TI suppliers consider certain information to be proprietary, and thus CAS numbers and other limited information may not be available for release.

In no event shall TI's liability arising out of such information exceed the total purchase price of the TI part(s) at issue in this document sold by TI to Customer on an annual basis.

OTHER QUALIFIED VERSIONS OF SN74LVC8T245 :

- Automotive: [SN74LVC8T245-Q1](#)
- Enhanced Product: [SN74LVC8T245-EP](#)

NOTE: Qualified Version Definitions:

- Automotive - Q100 devices qualified for high-reliability automotive applications targeting zero defects
- Enhanced Product - Supports Defense, Aerospace and Medical Applications

TAPE AND REEL INFORMATION

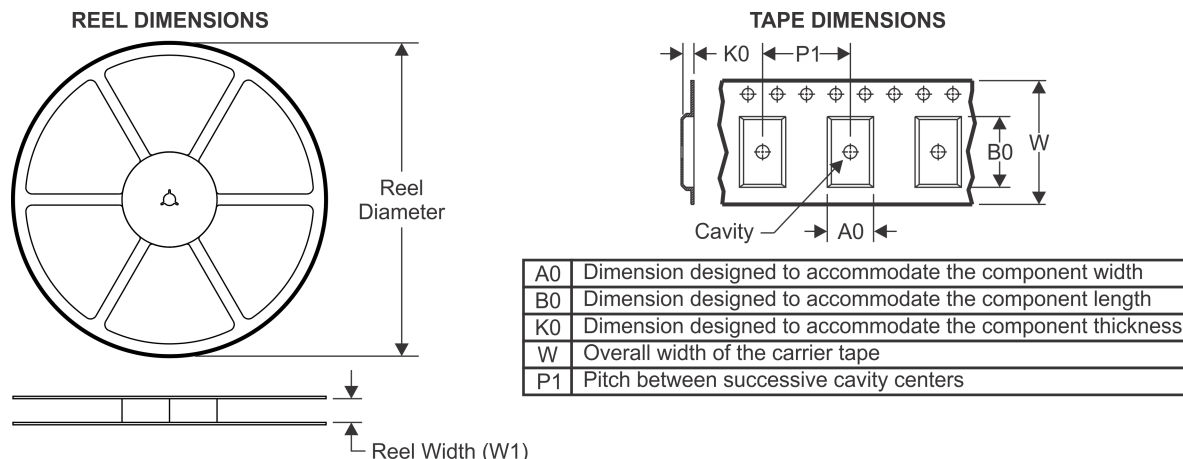

QUADRANT ASSIGNMENTS FOR PIN 1 ORIENTATION IN TAPE



*All dimensions are nominal

Device	Package Type	Package Drawing	Pins	SPQ	Reel Diameter (mm)	Reel Width W1 (mm)	A0 (mm)	B0 (mm)	K0 (mm)	P1 (mm)	W (mm)	Pin1 Quadrant
SN74LVC8T245DBQR	SSOP	DBQ	24	2500	330.0	16.4	6.5	9.0	2.1	8.0	16.0	Q1
SN74LVC8T245DBR	SSOP	DB	24	2000	330.0	16.4	8.2	8.8	2.5	12.0	16.0	Q1
SN74LVC8T245DGVR	TVSOP	DGV	24	2000	330.0	12.4	6.9	5.6	1.6	8.0	12.0	Q1
SN74LVC8T245DWR	SOIC	DW	24	2000	330.0	24.4	10.75	15.7	2.7	12.0	24.0	Q1
SN74LVC8T245NSR	SO	NS	24	2000	330.0	24.4	8.3	15.4	2.6	12.0	24.0	Q1
SN74LVC8T245PWR	TSSOP	PW	24	2000	330.0	16.4	6.95	8.3	1.6	8.0	16.0	Q1
SN74LVC8T245RHLR	VQFN	RHL	24	1000	180.0	12.4	3.8	5.8	1.2	8.0	12.0	Q1

TAPE AND REEL BOX DIMENSIONS

*All dimensions are nominal

Device	Package Type	Package Drawing	Pins	SPQ	Length (mm)	Width (mm)	Height (mm)
SN74LVC8T245DBQR	SSOP	DBQ	24	2500	853.0	449.0	35.0
SN74LVC8T245DBR	SSOP	DB	24	2000	853.0	449.0	35.0
SN74LVC8T245DGVR	TVSOP	DGV	24	2000	853.0	449.0	35.0
SN74LVC8T245DWR	SOIC	DW	24	2000	350.0	350.0	43.0
SN74LVC8T245NSR	SO	NS	24	2000	367.0	367.0	45.0
SN74LVC8T245PWR	TSSOP	PW	24	2000	853.0	449.0	35.0
SN74LVC8T245RHLR	VQFN	RHL	24	1000	210.0	185.0	35.0

TUBE

*All dimensions are nominal

Device	Package Name	Package Type	Pins	SPQ	L (mm)	W (mm)	T (μm)	B (mm)
SN74LVC8T245PW	PW	TSSOP	24	60	530	10.2	3600	3.5
SN74LVC8T245PW	PW	TSSOP	24	60	530	10.2	3600	3.5
SN74LVC8T245PWG4	PW	TSSOP	24	60	530	10.2	3600	3.5
SN74LVC8T245PWG4	PW	TSSOP	24	60	530	10.2	3600	3.5

DBQ (R-PDSO-G24)

PLASTIC SMALL-OUTLINE PACKAGE

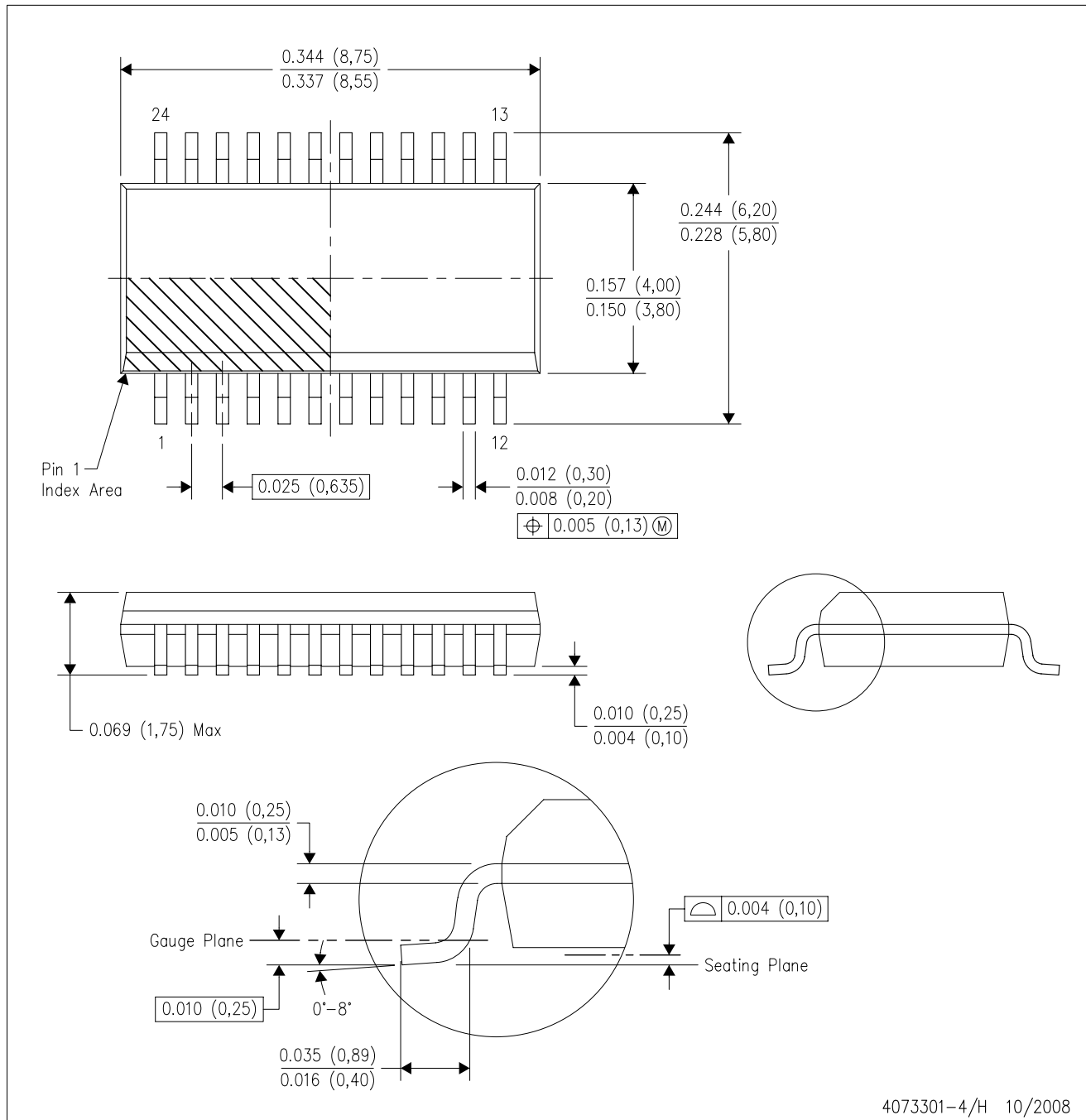

- NOTES:
- All linear dimensions are in inches (millimeters).
 - This drawing is subject to change without notice.
 - Body dimensions do not include mold flash or protrusion not to exceed 0.006 (0,15) per side.
 - Falls within JEDEC MO-137 variation AE.

PW0024A



PACKAGE OUTLINE

TSSOP - 1.2 mm max height

SMALL OUTLINE PACKAGE

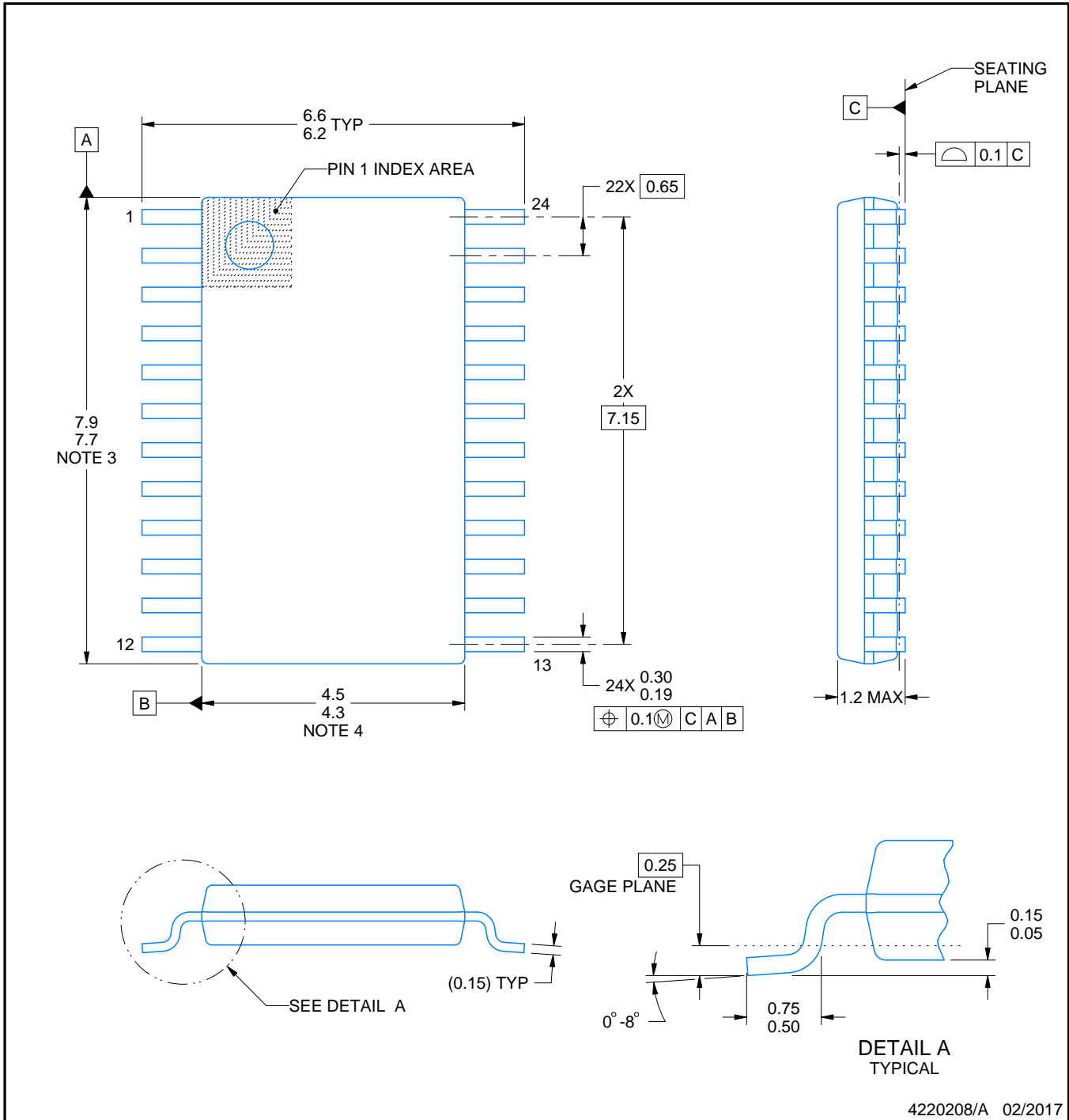

4220208/A 02/2017

NOTES:

1. All linear dimensions are in millimeters. Any dimensions in parenthesis are for reference only. Dimensioning and tolerancing per ASME Y14.5M.
2. This drawing is subject to change without notice.
3. This dimension does not include mold flash, protrusions, or gate burrs. Mold flash, protrusions, or gate burrs shall not exceed 0.15 mm per side.
4. This dimension does not include interlead flash. Interlead flash shall not exceed 0.25 mm per side.
5. Reference JEDEC registration MO-153.

EXAMPLE BOARD LAYOUT

PW0024A

TSSOP - 1.2 mm max height

SMALL OUTLINE PACKAGE

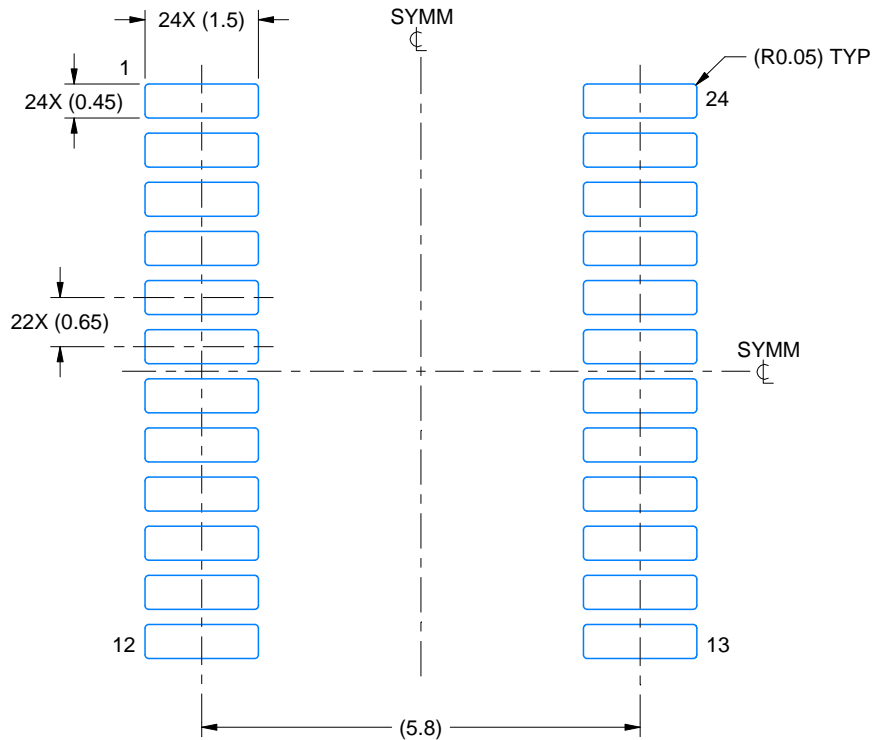

LAND PATTERN EXAMPLE
EXPOSED METAL SHOWN
SCALE: 10X

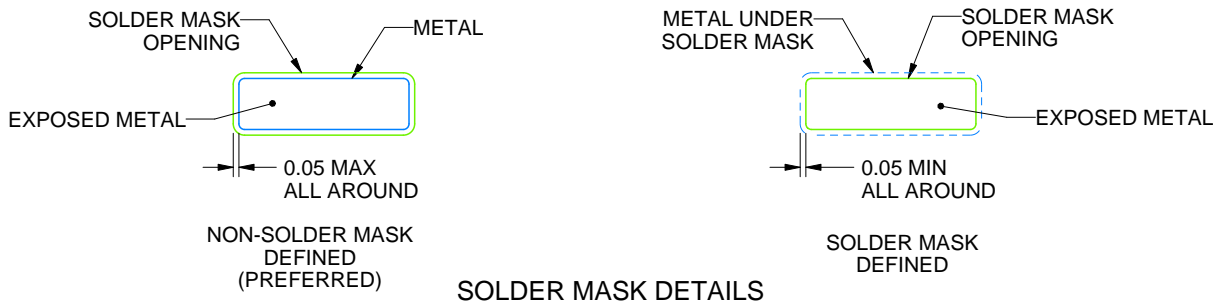

SOLDER MASK DETAILS

4220208/A 02/2017

NOTES: (continued)

- 6. Publication IPC-7351 may have alternate designs.
- 7. Solder mask tolerances between and around signal pads can vary based on board fabrication site.

EXAMPLE STENCIL DESIGN

PW0024A

TSSOP - 1.2 mm max height

SMALL OUTLINE PACKAGE

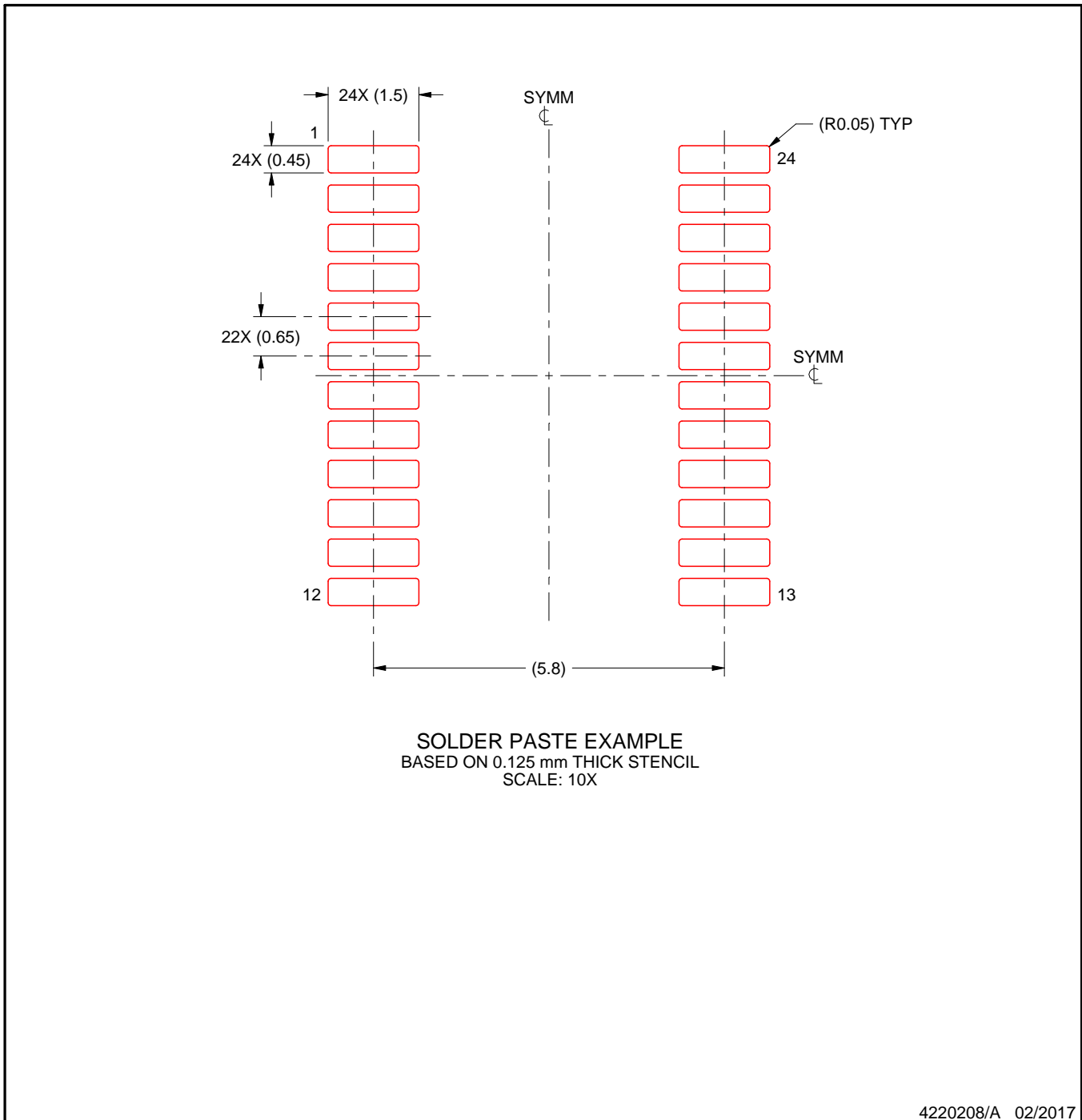

NOTES: (continued)

8. Laser cutting apertures with trapezoidal walls and rounded corners may offer better paste release. IPC-7525 may have alternate design recommendations.
9. Board assembly site may have different recommendations for stencil design.

MECHANICAL DATA

NS (R-PDSO-G**)

PLASTIC SMALL-OUTLINE PACKAGE

14-PINS SHOWN



- NOTES:
- A. All linear dimensions are in millimeters.
 - B. This drawing is subject to change without notice.
 - C. Body dimensions do not include mold flash or protrusion, not to exceed 0,15.

DGV (R-PDSO-G**)

PLASTIC SMALL-OUTLINE

24 PINS SHOWN



- NOTES: A. All linear dimensions are in millimeters.
 B. This drawing is subject to change without notice.
 C. Body dimensions do not include mold flash or protrusion, not to exceed 0,15 per side.
 D. Falls within JEDEC: 24/48 Pins – MO-153
 14/16/20/56 Pins – MO-194

DW (R-PDSO-G24)

PLASTIC SMALL OUTLINE

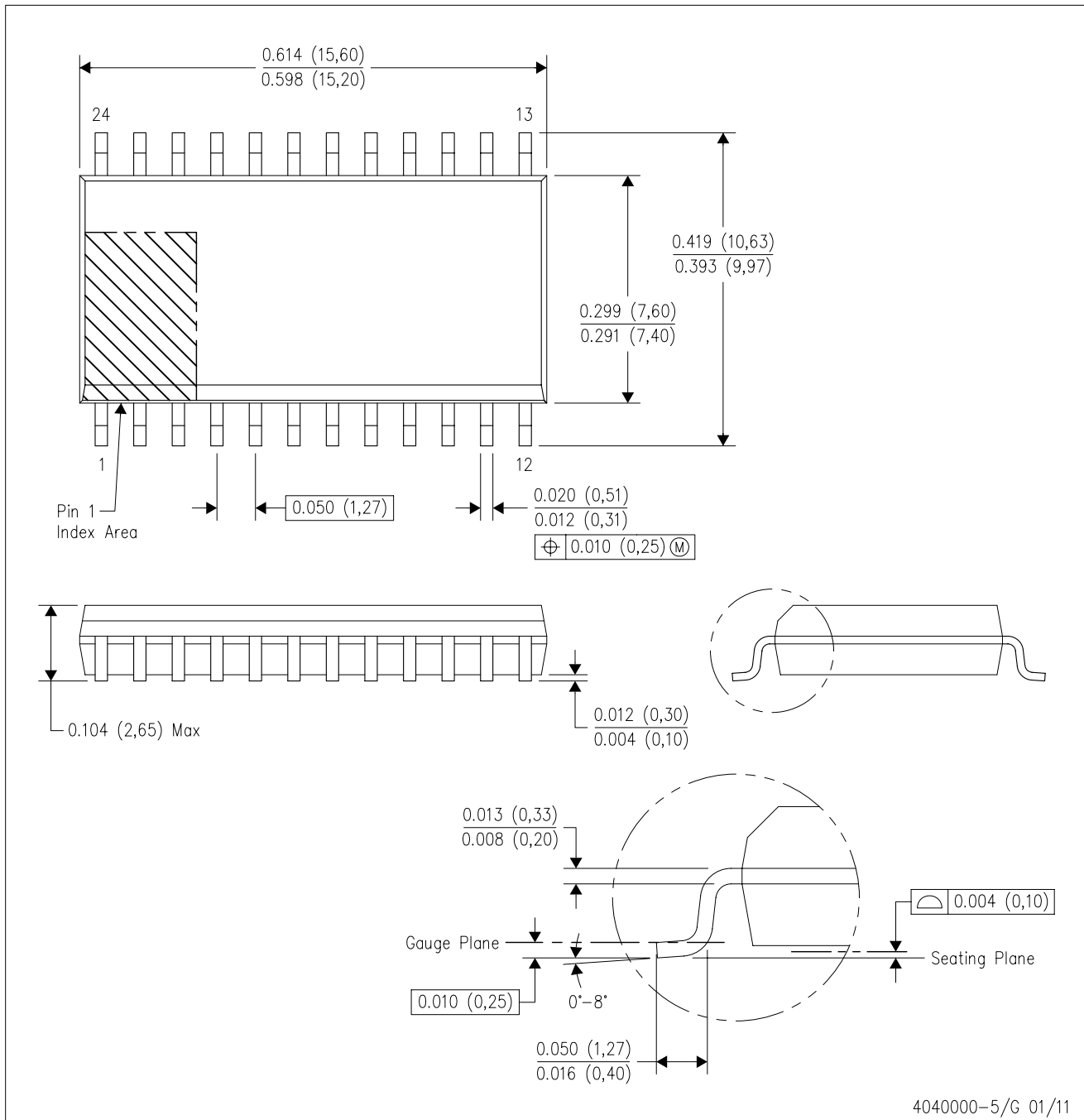

- NOTES:
- A. All linear dimensions are in inches (millimeters). Dimensioning and tolerancing per ASME Y14.5M-1994.
 - B. This drawing is subject to change without notice.
 - C. Body dimensions do not include mold flash or protrusion not to exceed 0.006 (0,15).
 - D. Falls within JEDEC MS-013 variation AD.

DB (R-PDSO-G**)

PLASTIC SMALL-OUTLINE

28 PINS SHOWN



- NOTES: A. All linear dimensions are in millimeters.
 B. This drawing is subject to change without notice.
 C. Body dimensions do not include mold flash or protrusion not to exceed 0,15.
 D. Falls within JEDEC MO-150

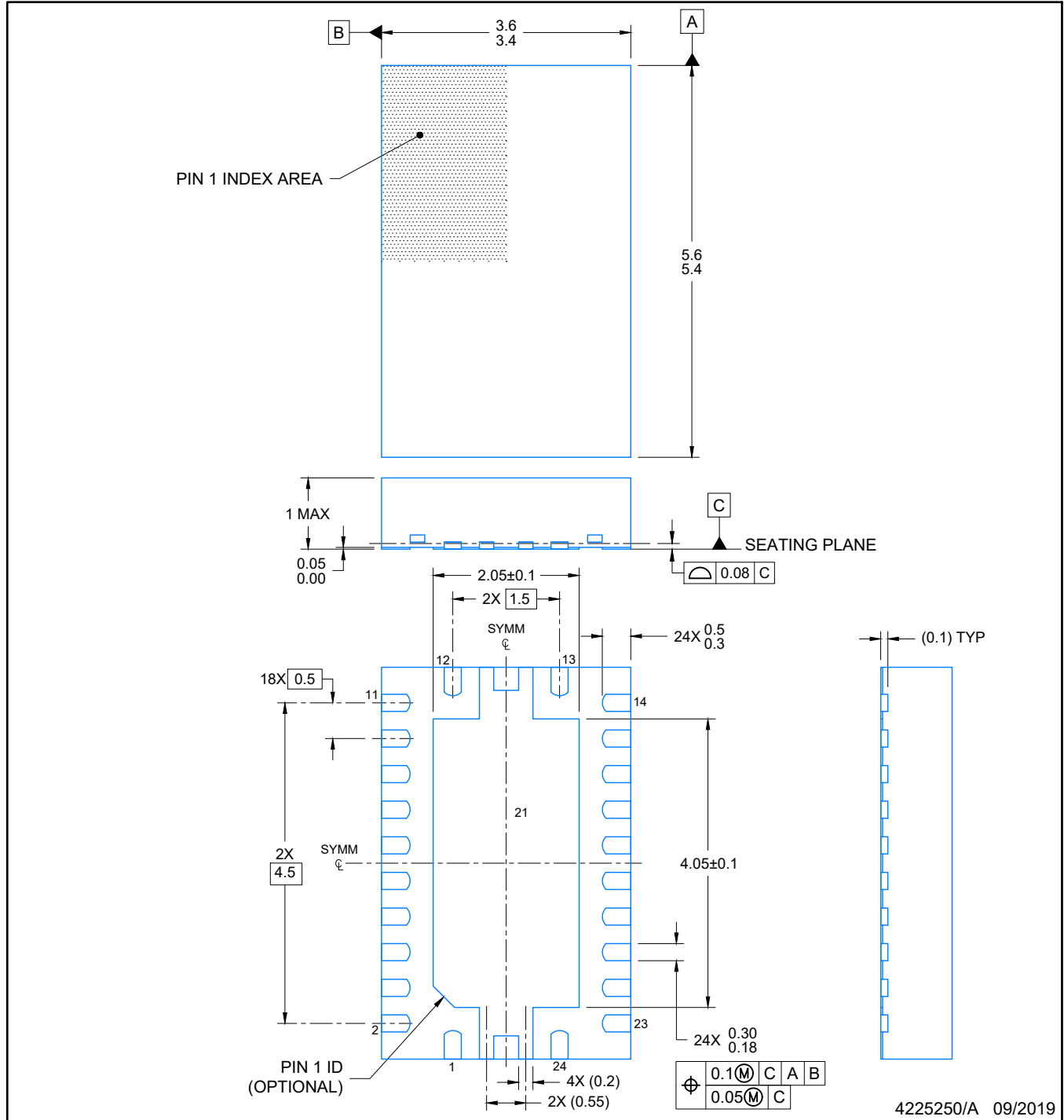

NOTES:

1. All linear dimensions are in millimeters. Any dimensions in parenthesis are for reference only. Dimensioning and tolerancing per ASME Y14.5M.
2. This drawing is subject to change without notice.
3. The package thermal pad must be soldered to the printed circuit board for optimal thermal and mechanical performance.

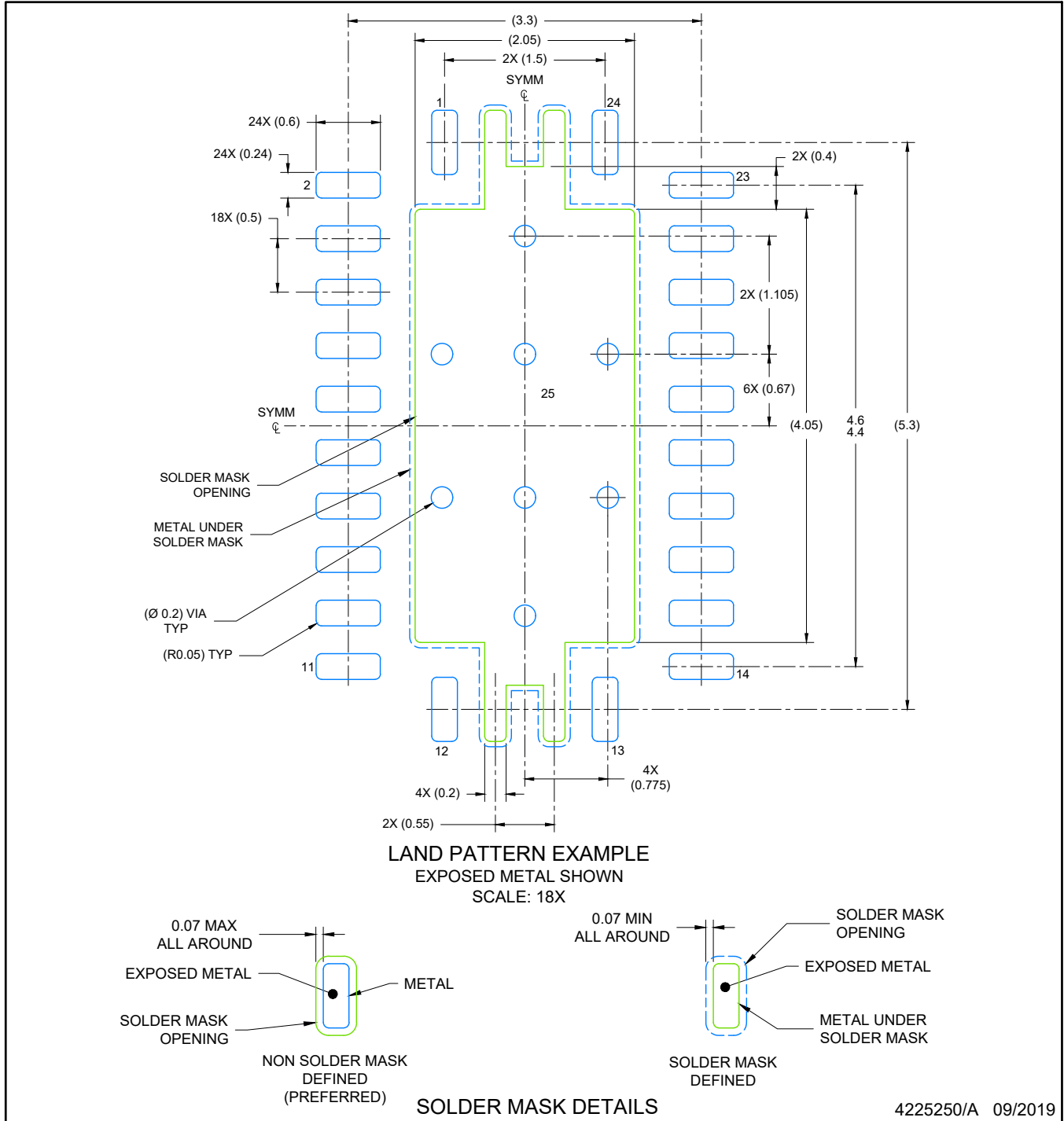

NOTES: (continued)

4. This package is designed to be soldered to a thermal pad on the board. For more information, see Texas Instruments literature number SLUA271 (www.ti.com/lit/sluea271).
5. Vias are optional depending on application, refer to device data sheet. If any vias are implemented, refer to their locations shown on this view. It is recommended that vias under paste be filled, plugged or tented.

EXAMPLE STENCIL DESIGN

VQFN - 1 mm max height

RHL0024A

PLASTIC QUAD FLATPACK- NO LEAD

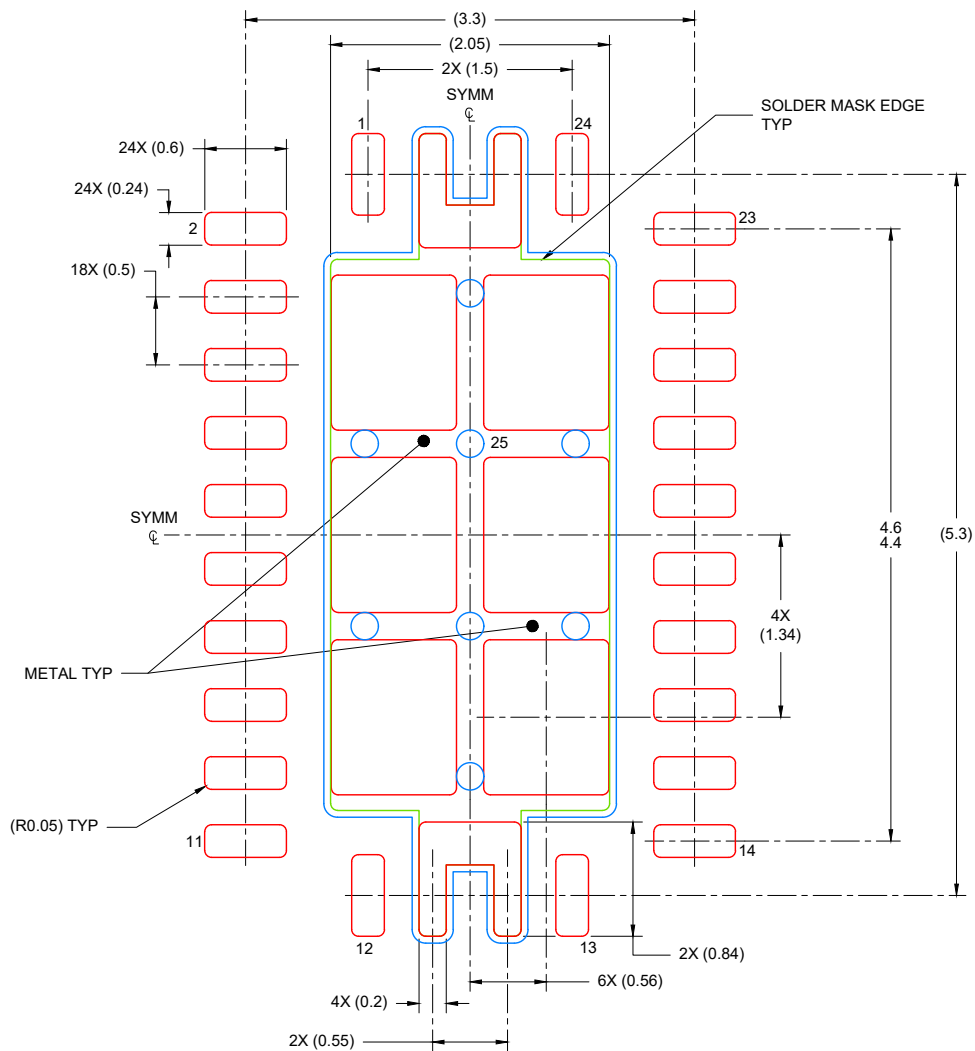

SOLDER PASTE EXAMPLE
BASED ON 0.125 mm THICK STENCIL

EXPOSED PAD
80% PRINTED COVERAGE BY AREA
SCALE: 18X

4225250/A 09/2019

NOTES: (continued)

6. Laser cutting apertures with trapezoidal walls and rounded corners may offer better paste release. IPC-7525 may have alternate design recommendations.

IMPORTANT NOTICE AND DISCLAIMER

TI PROVIDES TECHNICAL AND RELIABILITY DATA (INCLUDING DATA SHEETS), DESIGN RESOURCES (INCLUDING REFERENCE DESIGNS), APPLICATION OR OTHER DESIGN ADVICE, WEB TOOLS, SAFETY INFORMATION, AND OTHER RESOURCES "AS IS" AND WITH ALL FAULTS, AND DISCLAIMS ALL WARRANTIES, EXPRESS AND IMPLIED, INCLUDING WITHOUT LIMITATION ANY IMPLIED WARRANTIES OF MERCHANTABILITY, FITNESS FOR A PARTICULAR PURPOSE OR NON-INFRINGEMENT OF THIRD PARTY INTELLECTUAL PROPERTY RIGHTS.

These resources are intended for skilled developers designing with TI products. You are solely responsible for (1) selecting the appropriate TI products for your application, (2) designing, validating and testing your application, and (3) ensuring your application meets applicable standards, and any other safety, security, regulatory or other requirements.

These resources are subject to change without notice. TI grants you permission to use these resources only for development of an application that uses the TI products described in the resource. Other reproduction and display of these resources is prohibited. No license is granted to any other TI intellectual property right or to any third party intellectual property right. TI disclaims responsibility for, and you will fully indemnify TI and its representatives against, any claims, damages, costs, losses, and liabilities arising out of your use of these resources.

TI's products are provided subject to [TI's Terms of Sale](#) or other applicable terms available either on ti.com or provided in conjunction with such TI products. TI's provision of these resources does not expand or otherwise alter TI's applicable warranties or warranty disclaimers for TI products.

TI objects to and rejects any additional or different terms you may have proposed.

Mailing Address: Texas Instruments, Post Office Box 655303, Dallas, Texas 75265
Copyright © 2022, Texas Instruments Incorporated