

DUAL MICROPOWER LinCMOS™ VOLTAGE COMPARATOR

Check for Samples: [TLC393-Q1](#)

FEATURES

- Qualified for Automotive Applications
- AEC Q100 Qualified with the Following Results:
 - Device Temperature Grade 1: –40°C to 125°C Ambient Operating Temperature Range
 - Device HBM ESD Classification Level H2
 - Device CDM ESD Classification Level C4B
- ESD Protection Exceeds 500 V Per MIL-STD-883, Method 3015; Exceeds 50 V Using Machine Model (C = 200 pF, R = 0)
- Low Power: 110 μ W Typ at 5 V
- Fast Response Time: $t_{PLH} = 2.5 \mu$ s Typ With 5-mV Overdrive
- Single Supply Operation:
 - TLC393Q: 4 V to 16 V

APPLICATIONS

- Automotive Applications

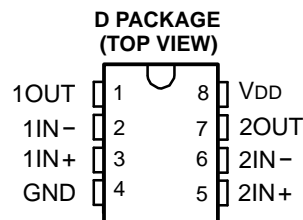
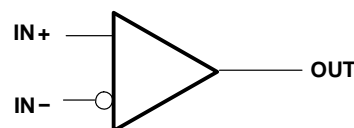
symbol (each comparator)

DESCRIPTION

The TLC393 consists of dual independent micropower voltage comparators designed to operate from a single supply. It is functionally similar to the LM393 but uses one-twentieth the power for similar response times. The open-drain MOS output stage interfaces to a variety of loads and supplies. For a similar device with a push-pull output configuration see the TLC3702 data sheet.

Texas Instruments LinCMOS™ process offers superior analog performance to standard CMOS processes. Along with the standard CMOS advantages of low power without sacrificing speed, high input impedance, and low bias currents, the LinCMOS™ process offers extremely stable input offset voltages, even with differential input stresses of several volts. This characteristic makes it possible to build reliable CMOS comparators.

The TLC393Q is characterized for operation over the full automotive temperature range of $T_A = -40^\circ\text{C}$ to 125°C

ORDERING INFORMATION⁽¹⁾

T_A	$V_{IO,max}$ AT 25°C	PACKAGE ⁽²⁾		ORDERABLE PART NUMBER	TOP-SIDE MARKING
–40°C to 125°C	5 mV	SOIC (D)	Tape and reel	TLC393QDRQ1	C393Q1

(1) For the most current package and ordering information, see the Package Option Addendum at the end of this document, or see the TI web site at <http://www.ti.com>.

(2) Package drawings, thermal data, and symbolization are available at <http://www.ti.com/packaging>.

Schematic

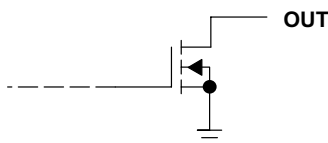
OPEN-DRAIN CMOS OUTPUT

Please be aware that an important notice concerning availability, standard warranty, and use in critical applications of Texas Instruments semiconductor products and disclaimers thereto appears at the end of this data sheet.

LinCMOS is a trademark of Texas Instruments.



These devices have limited built-in ESD protection. The leads should be shorted together or the device placed in conductive foam during storage or handling to prevent electrostatic damage to the MOS gates.

ABSOLUTE MAXIMUM RATINGS⁽¹⁾

over operating free-air temperature range (unless otherwise noted)

	VALUE		UNIT
	MIN	MAX	
Supply voltage range, V_{DD} ⁽²⁾	-0.3	18	V
Differential input voltage, V_{ID} ⁽³⁾		±18	V
Input voltage range, V_I	-0.3	V_{DD}	V
Output voltage range, V_O	-0.3	16	V
Input current, I_I		±5	mA
Output current, I_O		20	mA
Total supply current into V_{DD}		40	mA
Total current out of GND		40	mA
Package thermal impedance, θ_{JA} ^{(4), (5)}	D Package	126	°C/W
	PW Package	149	°C/W
Electrostatic discharge (ESD)	Human Body Model (HBM) AEC-Q100 Classification Level H2	2	kV
	Charge Device Model (CDM) AEC-Q100 Classification Level C4B	750	V
Operating free-air temperature range	-40	125	°C
Storage temperature range	-65	150	°C

- (1) Stresses beyond those listed under “absolute maximum ratings” may cause permanent damage to the device. These are stress ratings only, and functional operation of the device at these or any other conditions beyond those indicated under “recommended operating conditions” is not implied. Exposure to absolute-maximum-rated conditions for extended periods may affect device reliability.
- (2) All voltage values, except differential voltages, are with respect to network ground.
- (3) Differential voltages are at IN+ with respect to IN -
- (4) Maximum power dissipation is a function of $T_J(\text{max})$, θ_{JA} , and T_A . The maximum allowable power dissipation at any allowable ambient temperature is $P_D = (T_J(\text{max}) - T_A)/\theta_{JA}$. Operating at the absolute maximum T_J of 150°C can affect reliability.
- (5) The package thermal impedance is calculated in accordance with JESD 51-7.

RECOMMENDED OPERATING CONDITIONS

over operating free-air temperature range (unless otherwise noted)

	MIN	NOM	MAX	UNIT
Supply voltage, V_{DD}	4	5	16	V
Common-mode input voltage, V_{IC}	0		$V_{DD} - 1.5$	V
Low-level output current, I_{OL}			20	mA
Operating free-air temperature, T_A	-40		125	°C

ELECTRICAL CHARACTERISTICS

 at specified operating free-air temperature, $V_{DD} = 5\text{ V}$ (unless otherwise noted)

PARAMETER		TEST CONDITIONS ⁽¹⁾	T_A	MIN	TYP	MAX	UNIT
V_{IO}	Input offset voltage	$V_{IC} = V_{ICRmin}$, $V_{DD} = 5\text{ V to }10\text{ V}$, See ⁽²⁾	25°C		1.4	5	mV
			–40°C to 125°C			10	
I_{IO}	Input offset current	$V_{IC} = 2.5\text{ V}$	25°C		1		pA
			125°C			15	nA
I_{IB}	Input bias current	$V_{IC} = 2.5\text{ V}$	25°C		5		pA
			125°C			30	nA
V_{ICR}	Common-mode input voltage range		25°C	0 to $V_{DD} - 1$			V
			–40°C to 125°C	0 to $V_{DD} - 1.5$			
CMMR	Common-mode rejection ratio	$V_{IC} = V_{ICRmin}$	25°C		84		dB
			125°C		84		
			–40°C		84		
k_{SVR}	Supply-voltage rejection ratio	$V_{DD} = 5\text{ V to }10\text{ V}$	25°C		85		dB
			125°C		84		
			–40°C		84		
V_{OL}	Low-level output voltage	$V_{ID} = -1\text{ V}$, $I_{OL} = 6\text{ mA}$	25°C		300	400	mV
			125°C			800	
I_{OH}	High-level output current	$V_{ID} = 1\text{ V}$, $V_O = 5\text{ V}$	25°C		0.8	40	nA
			125°C			1	∞A
I_{DD}	Supply current (both comparators)	Outputs low, No load	25°C		22	40	∞A
			–40°C to 125°C			90	

(1) All characteristics are measured with zero common-mode voltage unless otherwise noted.

 (2) The offset voltage limits given are the maximum values required to drive the output up to 4.5 V or down to 0.3 V (with a 2.5-kM load to V_{DD}).

SWITCHING CHARACTERISTICS

 $V_{DD} = 5\text{ V}$, $T_A = 25^\circ\text{C}$ (see Figure 3)

PARAMETER		TEST CONDITIONS		MIN	TYP	MAX	UNIT
t_{PLH}	Propagation delay time, low-to-high level output	$f = 10\text{ kHz}$, $C_L = 15\text{ pF}$	Overdrive = 2 mV		4.5		∞s
			Overdrive = 5 mV		2.5		
			Overdrive = 10 mV		1.7		
			Overdrive = 20 mV		1.2		
			Overdrive = 40 mV		1.1		
t_{PHL}	Propagation delay time, high-to-low level output	$f = 10\text{ kHz}$, $C_L = 15\text{ pF}$	$V_I = 1.4\text{-V step at IN +}$			1.1	∞s
			Overdrive = 2 mV		3.6		
			Overdrive = 5 mV		2.1		
			Overdrive = 10 mV		1.3		
			Overdrive = 20 mV		0.85		
			Overdrive = 40 mV		0.55		
			$V_I = 1.4\text{-V step at IN +}$			0.1	
t_f	Fall time, output	$f = 10\text{ kHz}$, $C_L = 15\text{ pF}$	Overdrive = 50 mV		22		∞s

PARAMETER MEASUREMENT INFORMATION

The TLC393 contains a digital output stage which, if held in the linear region of the transfer curve, can cause damage to the device. Conventional operational amplifier/comparator testing incorporates the use of a servo loop that is designed to force the device output to a level within this linear region. Since the servo-loop method of testing cannot be used, the following alternatives for testing parameters such as input offset voltage, common-mode rejection ratio, etc., are suggested.

To verify that the input offset voltage falls within the limits specified, the limit value is applied to the input as shown in Figure 1(a). With the noninverting input positive with respect to the inverting input, the output should be high. With the input polarity reversed, the output should be low.

A similar test can be made to verify the input offset voltage at the common-mode extremes. The supply voltages can be slewed as shown in Figure 1(b) for the V_{ICR} test, rather than changing the input voltages, to provide greater accuracy.

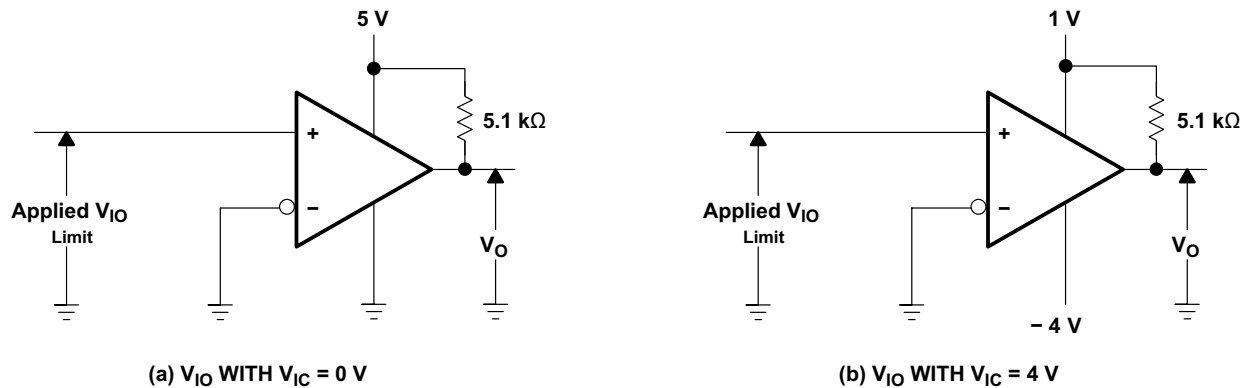

Figure 1. Method for Verifying That Input Offset Voltage Is Within Specified Limits

A close approximation of the input offset voltage can be obtained by using a binary search method to vary the differential input voltage while monitoring the output state. When the applied input voltage differential is equal, but opposite in polarity, to the input offset voltage, the output changes states.

Figure 2 illustrates a practical circuit for direct dc measurement of input offset voltage that does not bias the comparator in the linear region. The circuit consists of a switching-mode servo loop in which U1A generates a triangular waveform of approximately 20-mV amplitude. U1B acts as a buffer, with C2 and R4 removing any residual dc offset. The signal is then applied to the inverting input of the comparator under test, while the noninverting input is driven by the output of the integrator formed by U1C through the voltage divider formed by R9 and R10. The loop reaches a stable operating point when the output of the comparator under test has a duty cycle of exactly 50%, which can only occur when the incoming triangle wave is sliced symmetrically or when the voltage at the noninverting input exactly equals the input offset voltage.

The voltage divider formed by R9 and R10 provides an increase in input offset voltage by a factor of 100 to make measurement easier. The values of R5, R8, R9, and R10 can significantly influence the accuracy of the reading; therefore, it is suggested that their tolerance level be 1% or lower.

Measuring the extremely low values of input current requires isolation from all other sources of leakage current and compensation for the leakage of the test socket and board. With a good picoammeter, the socket and board leakage can be measured with no device in the socket. Subsequently, this open-socket leakage value can be subtracted from the measurement obtained with a device in the socket to obtain the actual input current of the device.

PARAMETER MEASUREMENT INFORMATION (continued)

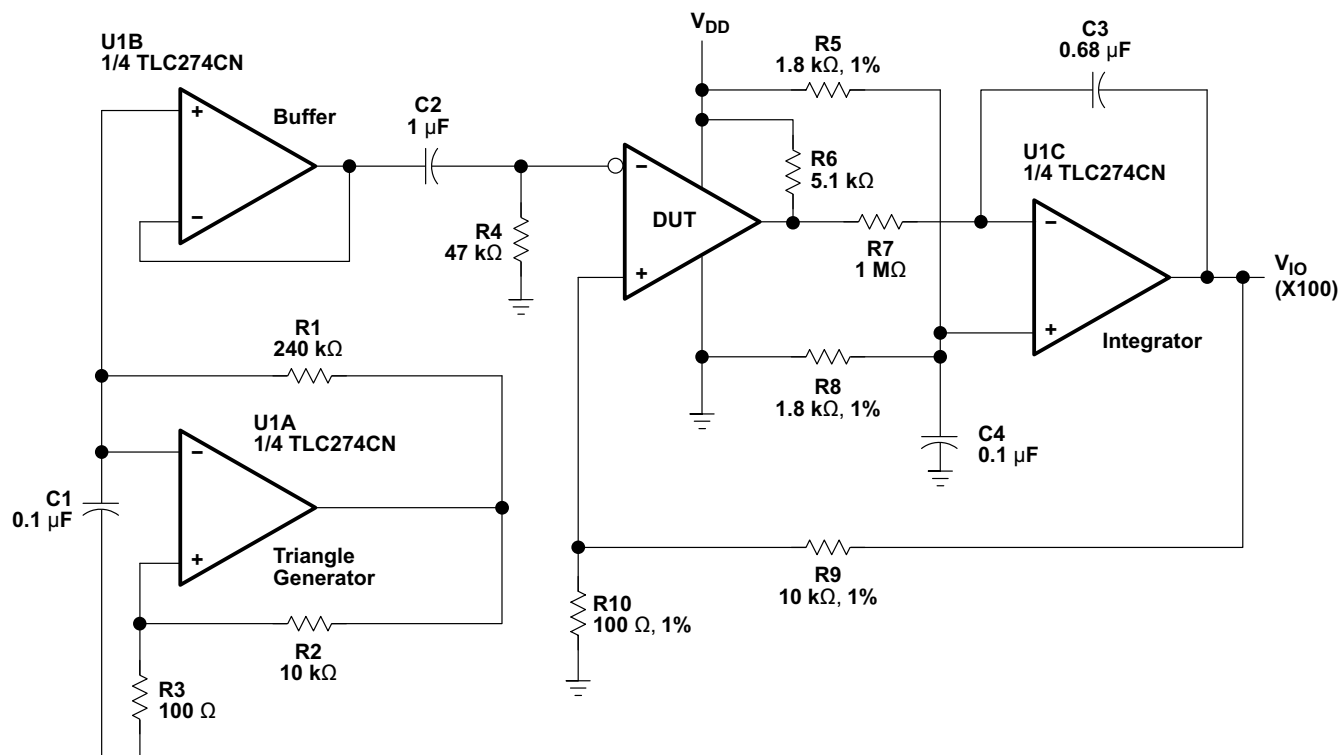
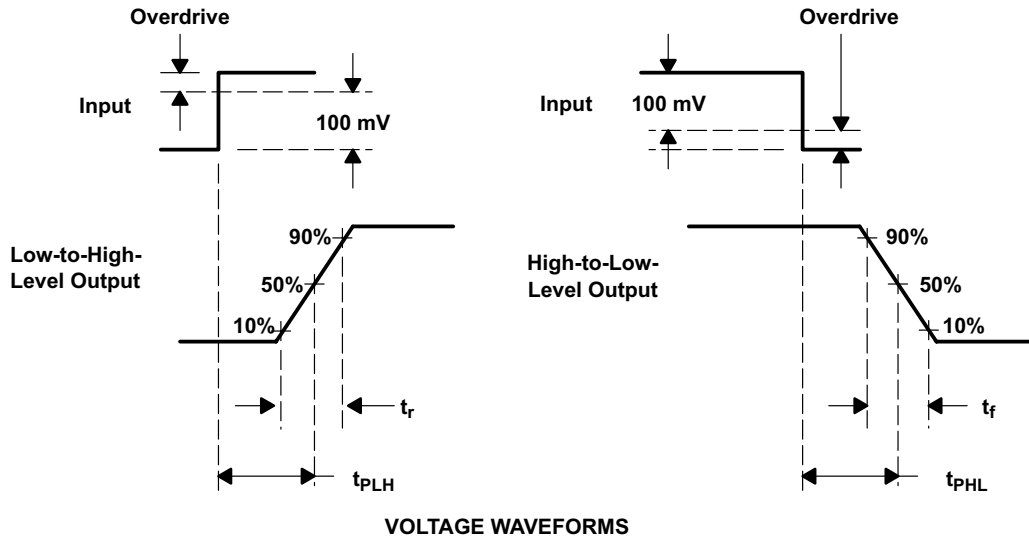
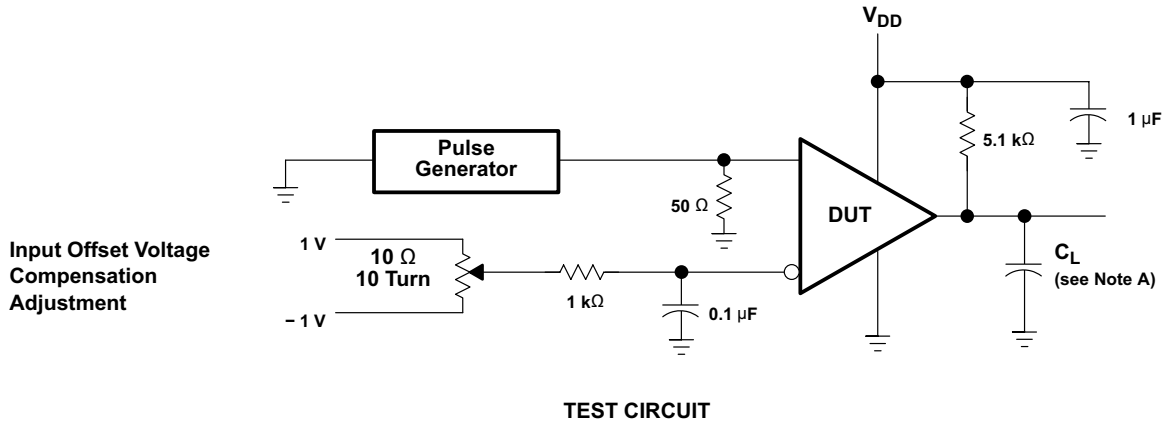

Figure 2. Circuit for Input Offset Voltage Measurement

Propagation delay time is defined as the interval between the application of an input step function and the instant when the output reaches 50% of its maximum value. Propagation delay time, low-to-high level output, is measured from the leading edge of the input pulse, while propagation delay time, high-to-low level output, is measured from the trailing edge of the input pulse. Propagation delay time measurement at low input signal levels can be greatly affected by the input offset voltage. The offset voltage should be balanced by the adjustment at the inverting input (as shown in Figure 3) so that the circuit is just at the transition point. Then a low signal, for example, 105 mV or 5 mV overdrive, causes the output to change state.

PARAMETER MEASUREMENT INFORMATION (continued)



A. C_L includes probe and jig capacitance.

Figure 3. Propagation Delay, Rise Time, and Fall Time Circuit and Voltage Waveforms

Table 1. Table of Graphs

			FIGURE
V_{IO}	Input offset voltage	Distribution	Figure 4
I_{IB}	Input bias current	vs Free-air temperature	Figure 5
CMRR	Common-mode rejection ratio	vs Free-air temperature	Figure 6
k_{SVR}	Supply-voltage rejection ratio	vs Free-air temperature	Figure 7
V_{OL}	Low-level output voltage	vs Low-level output current	Figure 8
		vs Free-air temperature	Figure 9
I_{OH}	Low-level output current	vs High-level output voltage	Figure 10
		vs Free-air temperature	Figure 11
I_{DD}	Supply current	vs Supply voltage	Figure 12
		vs Free-air temperature	Figure 13
t_{PLH}	Low-to-high level output propagation delay time	vs Supply voltage	Figure 14
t_{PHL}	High-to-low level output propagation delay time	vs Supply voltage	Figure 15
	Low-to-high-level output response	Low-to-high level output propagation delay time	Figure 16
	High-to-low level output response	High-to-low level output propagation delay time	Figure 17
t_f	Fall time	vs Supply voltage	Figure 18

TYPICAL CHARACTERISTICS

Data at high and low temperatures are applicable only within the related operating free-air temperature ranges of the various devices.

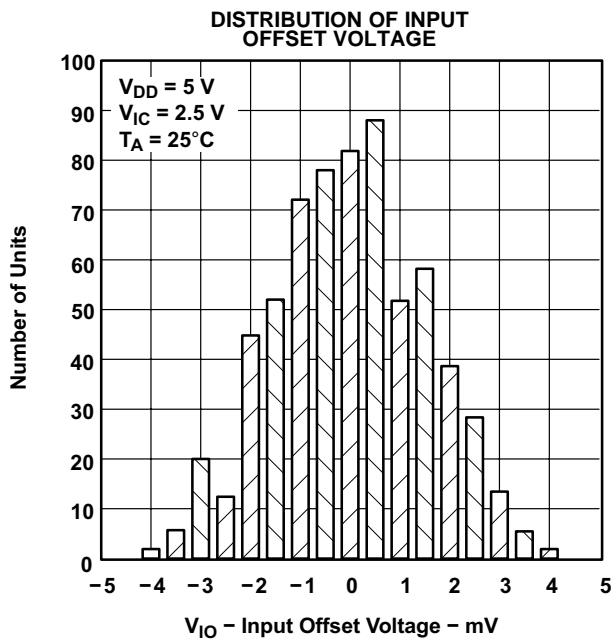

Figure 4.

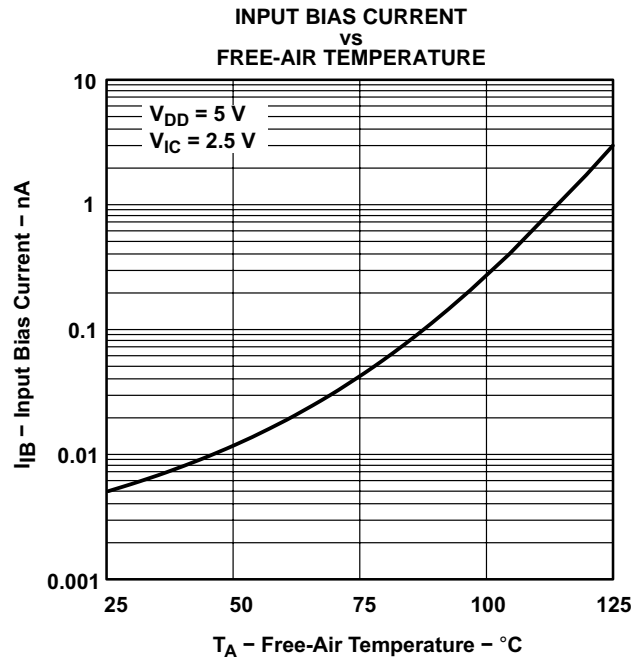

Figure 5.

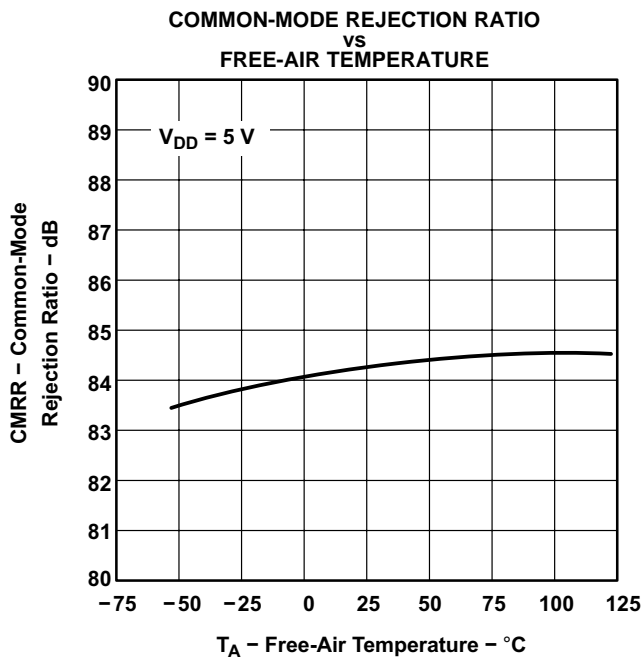

Figure 6.

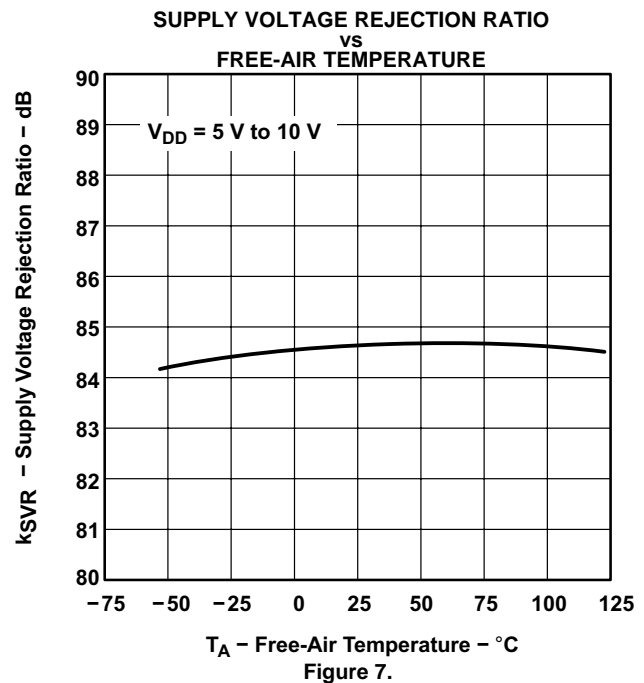

Figure 7.

TYPICAL CHARACTERISTICS (continued)

Data at high and low temperatures are applicable only within the rated operating free-air temperature ranges of the various devices.

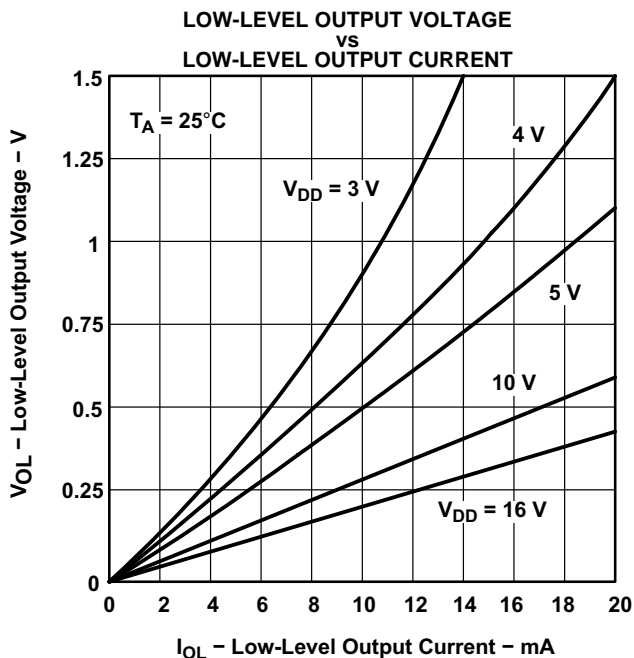

Figure 8.

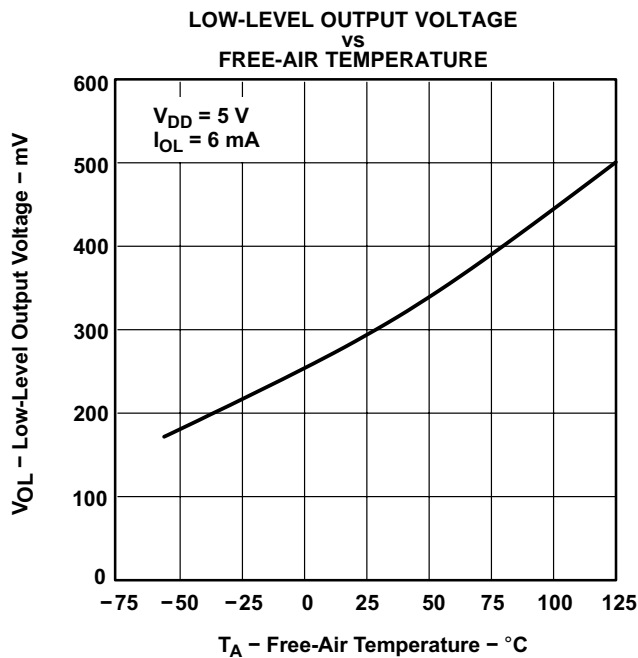

Figure 9.

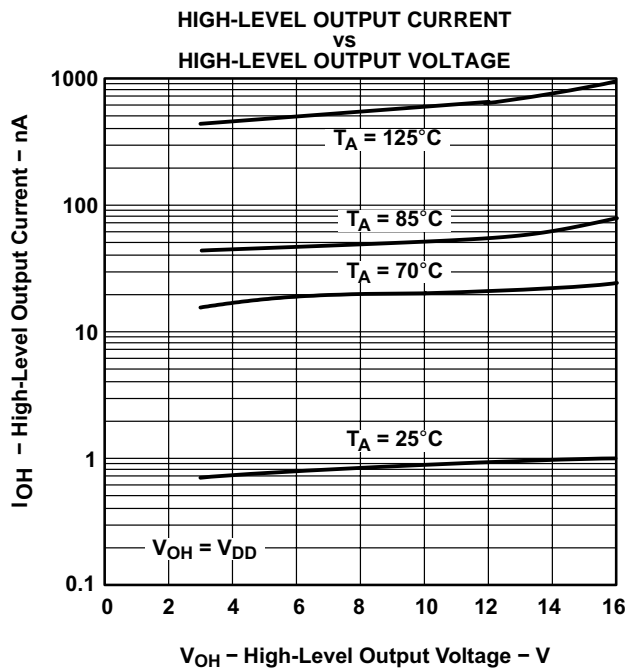

Figure 10.

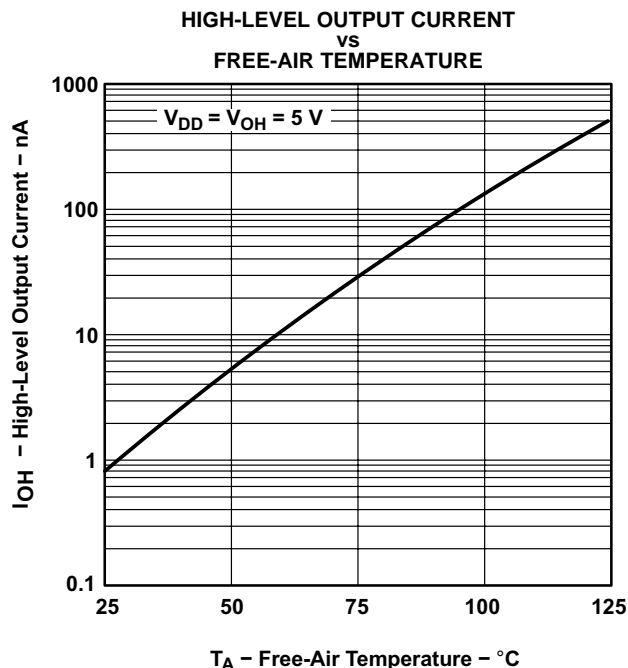
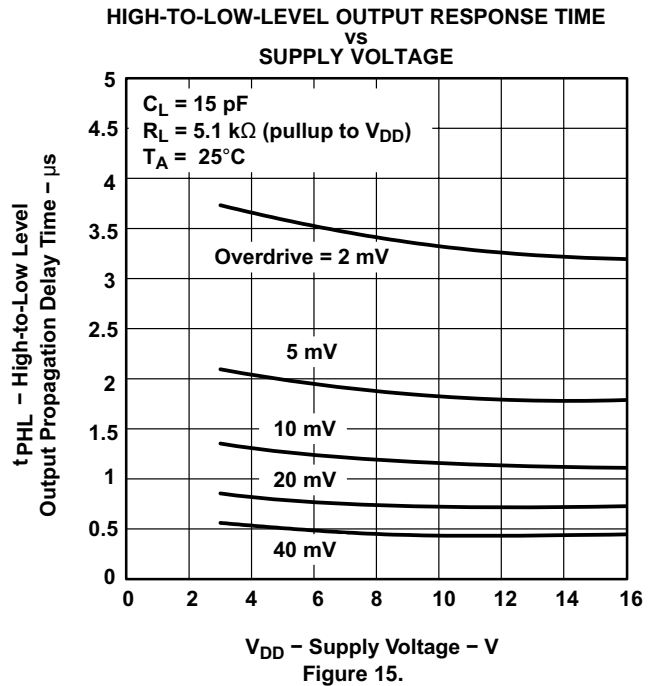
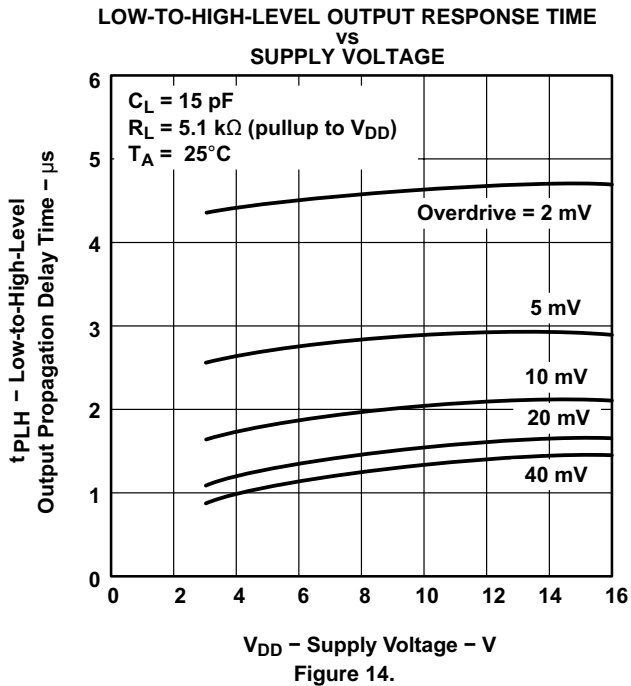
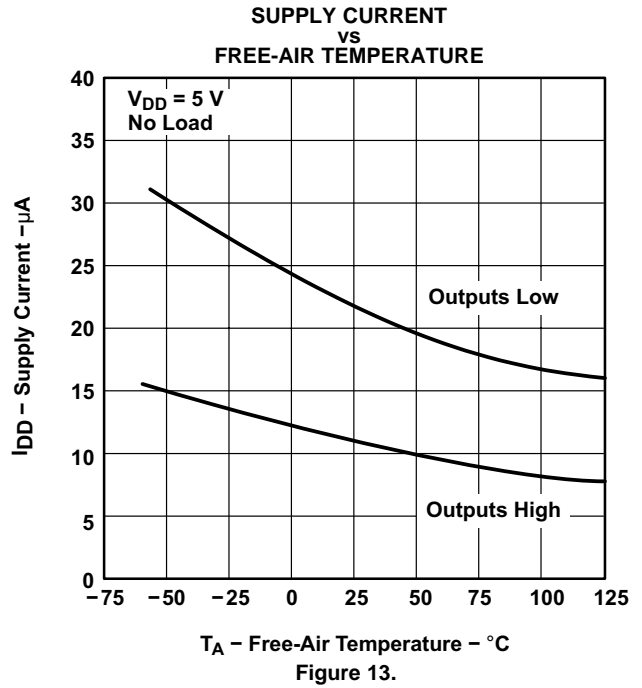
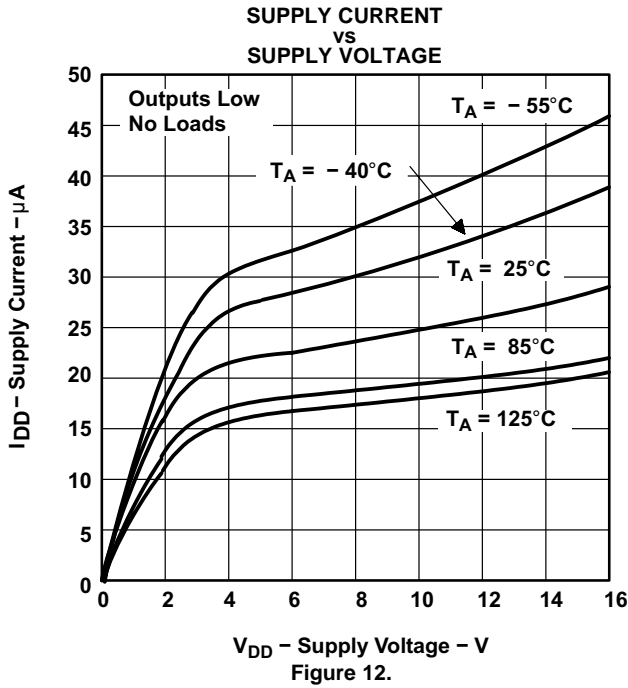

Figure 11.

TYPICAL CHARACTERISTICS (continued)

Data at high and low temperatures are applicable only within the rated operating free-air temperature ranges of the various devices.



TYPICAL CHARACTERISTICS (continued)

Data at high and low temperatures are applicable only within the reated operating free-air temperature ranges of the various devices.

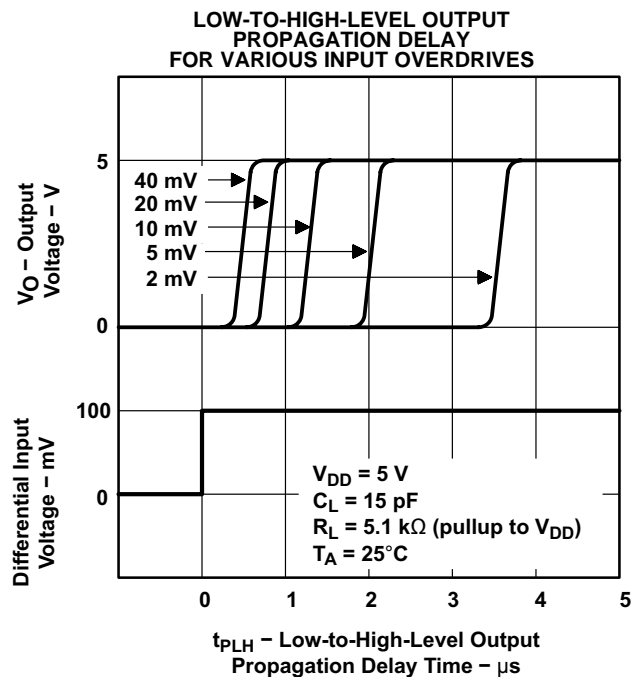

Figure 16.

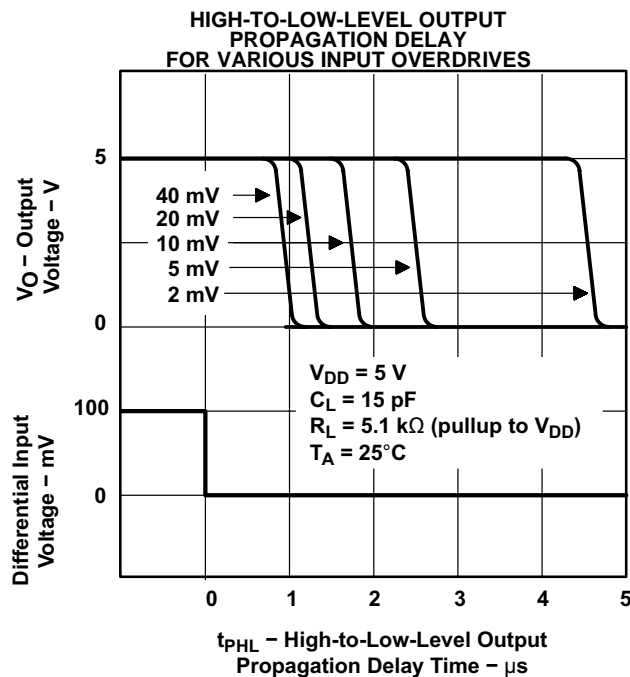

Figure 17.

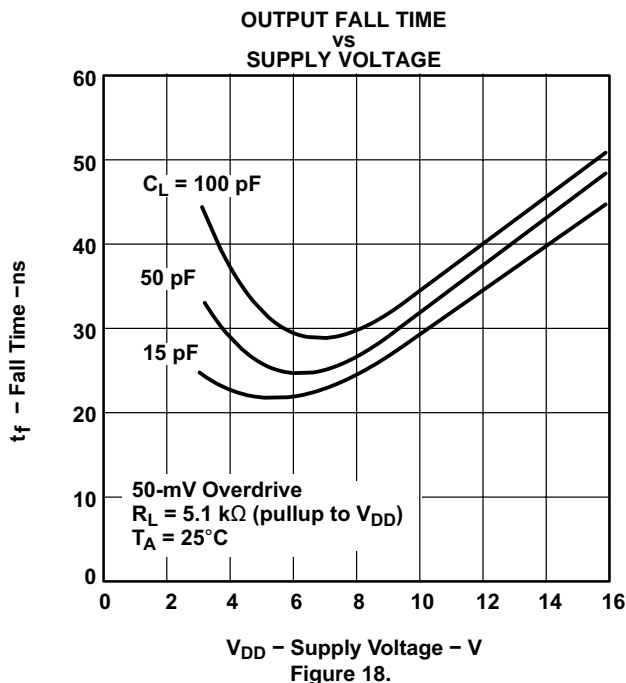

Figure 18.

APPLICATION INFORMATION

The input should always remain within the supply rails in order to avoid forward biasing the diodes in the electrostatic discharge (ESD) protection structure. If either input exceeds this range, the device will not be damaged as long as the input current is limited to less than 5 mA. To maintain the expected output state, the inputs must remain within the common-mode range. For example, at 25°C with $V_{DD} = 5\text{ V}$, both inputs must remain between -0.2 V and 4 V to assure proper device operation.

To assure reliable operation, the supply should be decoupled with a capacitor ($0.1\text{-}\mu\text{F}$) positioned as close to the device as possible.

The TLC393 has internal ESD-protection circuits that prevent functional failures at voltages up to 2000 V as tested under MIL-STD-883C, Method 3015.2; however, care should be exercised in handling these devices, as exposure to ESD may result in the degradation of the device parametric performance.

Table 2. Table of Applications

	FIGURE
Pulse-Width-Modulated Motor Speed Controller	Figure 19
Enhanced Supply Supervisor	Figure 20
Two-Phase Nonoverlapping Clock Generator	Figure 21

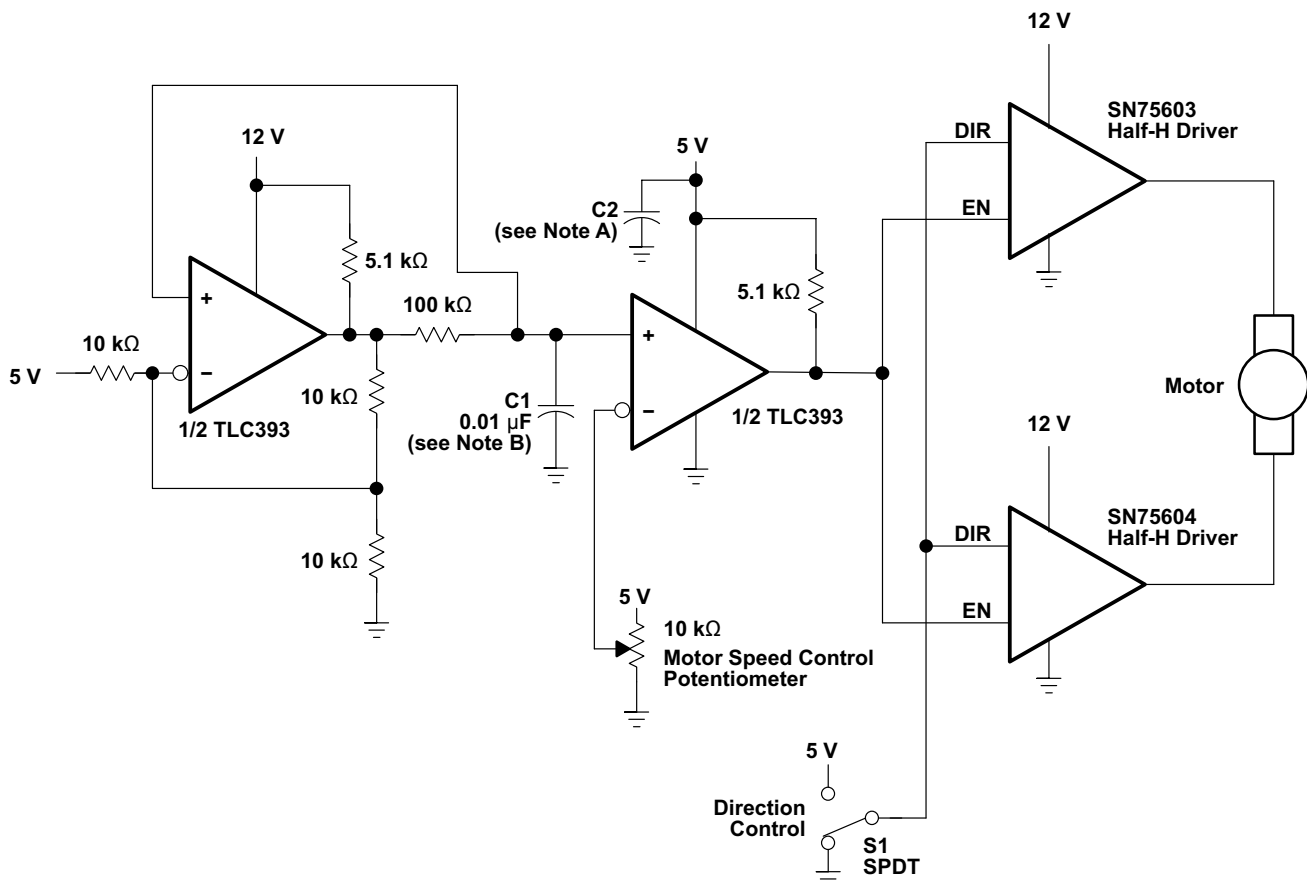

- A. The recommended minimum capacitance is $10\text{ }\mu\text{F}$ to eliminate common ground switching noise.
- B. Adjust C1 for change in oscillator frequency.

Figure 19. Pulse-Width-Modulated Motor Speed Controller

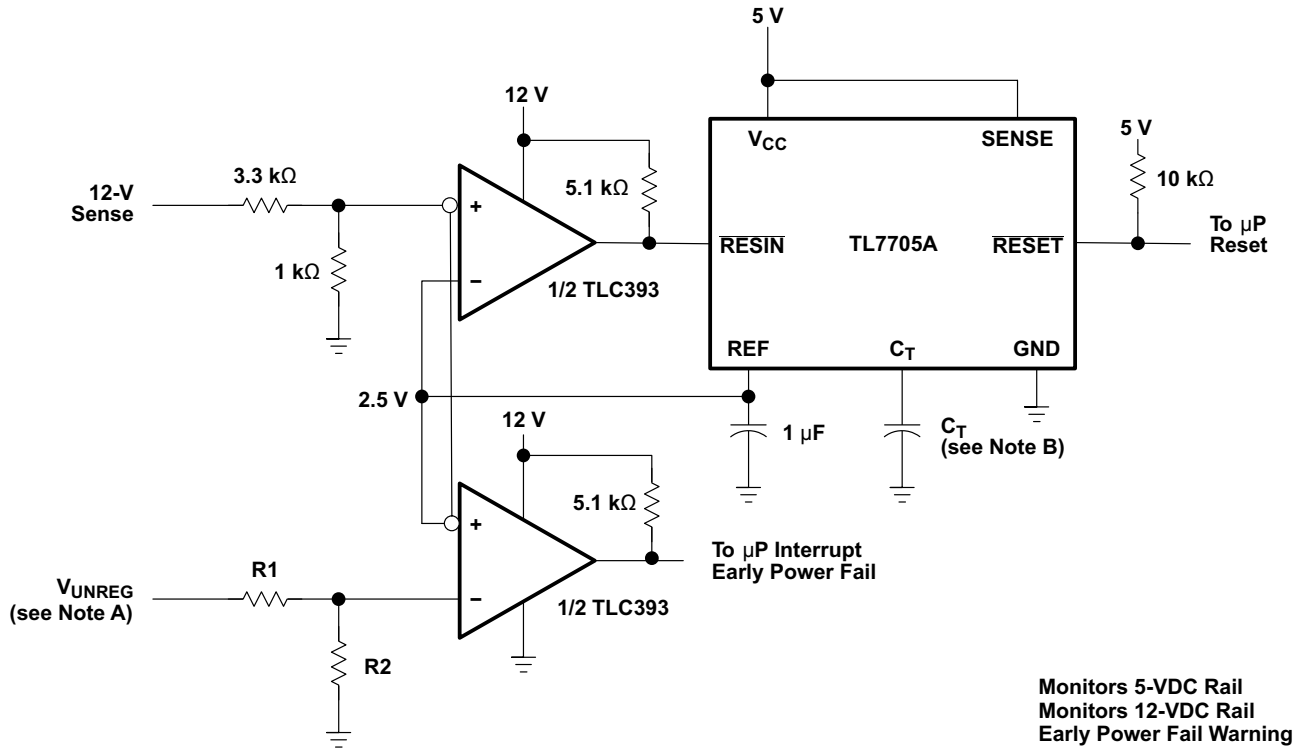

- A.
$$V_{UNREG} = 2.5 \frac{(R1 + R2)}{R2}$$
- B. The value of C_T determines the time delay of reset.

Monitors 5-VDC Rail
Monitors 12-VDC Rail
Early Power Fail Warning

Figure 20. Enhanced Supply Supervisor

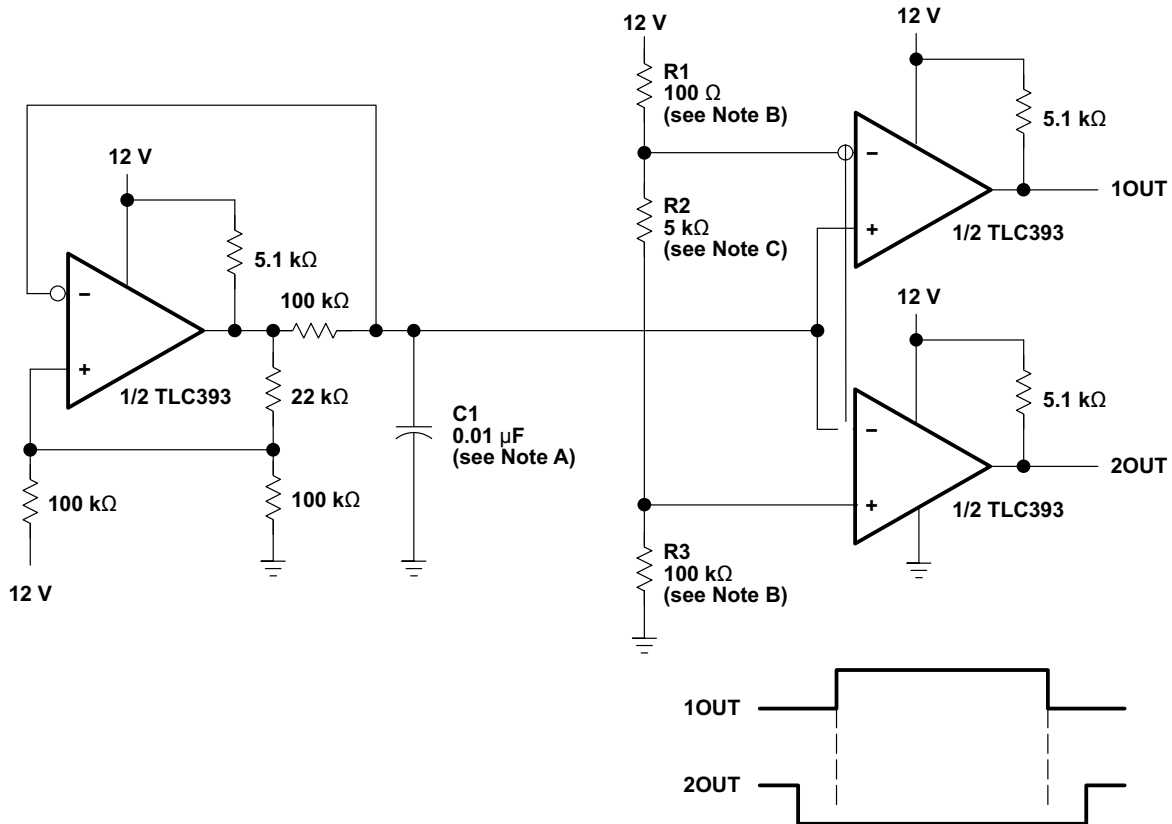

- A. Adjust C1 for a change in oscillator frequency where:
 $1/f = 1.85(100\text{ k}\Omega)C1$
- B. Adjust R1 and R3 to change duty cycle
- C. Adjust R2 to change deadtime

Figure 21. Two-Phase Nonoverlapping Clock Generator

REVISION HISTORY

Changes from Original (September 2004) to Revision A **Page**

- Deleted Feature: Qualified in Accordance With AEC-Q100 1
 - Deleted Feature: Customer-Specific Configuration Control... 1
-

Changes from Revision A (April 2008) to Revision B **Page**

- Added Feature: AEC Q100 Qualified with the Following Results: 1
 - Deleted the TSSOP (PW) Package from the Ordering Information table 1
 - Added Electrostatic discharge (ESD) to the Absolute Maximum table 2
-

PACKAGING INFORMATION

Orderable Device	Status (1)	Package Type	Package Drawing	Pins	Package Qty	Eco Plan (2)	Lead finish/ Ball material (6)	MSL Peak Temp (3)	Op Temp (°C)	Device Marking (4/5)	Samples
TLC393QDRG4Q1	ACTIVE	SOIC	D	8	2500	RoHS & Green	NIPDAU	Level-1-260C-UNLIM	-40 to 125	C393Q1	Samples
TLC393QDRQ1	ACTIVE	SOIC	D	8	2500	RoHS & Green	NIPDAU	Level-1-260C-UNLIM	-40 to 125	C393Q1	Samples

(1) The marketing status values are defined as follows:

ACTIVE: Product device recommended for new designs.

LIFEBUY: TI has announced that the device will be discontinued, and a lifetime-buy period is in effect.

NRND: Not recommended for new designs. Device is in production to support existing customers, but TI does not recommend using this part in a new design.

PREVIEW: Device has been announced but is not in production. Samples may or may not be available.

OBSELETE: TI has discontinued the production of the device.

(2) **RoHS:** TI defines "RoHS" to mean semiconductor products that are compliant with the current EU RoHS requirements for all 10 RoHS substances, including the requirement that RoHS substance do not exceed 0.1% by weight in homogeneous materials. Where designed to be soldered at high temperatures, "RoHS" products are suitable for use in specified lead-free processes. TI may reference these types of products as "Pb-Free".

RoHS Exempt: TI defines "RoHS Exempt" to mean products that contain lead but are compliant with EU RoHS pursuant to a specific EU RoHS exemption.

Green: TI defines "Green" to mean the content of Chlorine (Cl) and Bromine (Br) based flame retardants meet JS709B low halogen requirements of <=1000ppm threshold. Antimony trioxide based flame retardants must also meet the <=1000ppm threshold requirement.

(3) MSL, Peak Temp. - The Moisture Sensitivity Level rating according to the JEDEC industry standard classifications, and peak solder temperature.

(4) There may be additional marking, which relates to the logo, the lot trace code information, or the environmental category on the device.

(5) Multiple Device Markings will be inside parentheses. Only one Device Marking contained in parentheses and separated by a "~" will appear on a device. If a line is indented then it is a continuation of the previous line and the two combined represent the entire Device Marking for that device.

(6) Lead finish/Ball material - Orderable Devices may have multiple material finish options. Finish options are separated by a vertical ruled line. Lead finish/Ball material values may wrap to two lines if the finish value exceeds the maximum column width.

Important Information and Disclaimer:The information provided on this page represents TI's knowledge and belief as of the date that it is provided. TI bases its knowledge and belief on information provided by third parties, and makes no representation or warranty as to the accuracy of such information. Efforts are underway to better integrate information from third parties. TI has taken and continues to take reasonable steps to provide representative and accurate information but may not have conducted destructive testing or chemical analysis on incoming materials and chemicals. TI and TI suppliers consider certain information to be proprietary, and thus CAS numbers and other limited information may not be available for release.

In no event shall TI's liability arising out of such information exceed the total purchase price of the TI part(s) at issue in this document sold by TI to Customer on an annual basis.

OTHER QUALIFIED VERSIONS OF TLC393-Q1 :

- Catalog: [TLC393](#)

NOTE: Qualified Version Definitions:

- Catalog - TI's standard catalog product



D0008A

PACKAGE OUTLINE

SOIC - 1.75 mm max height

SMALL OUTLINE INTEGRATED CIRCUIT



4214825/C 02/2019

NOTES:

- Linear dimensions are in inches [millimeters]. Dimensions in parenthesis are for reference only. Controlling dimensions are in inches. Dimensioning and tolerancing per ASME Y14.5M.
- This drawing is subject to change without notice.
- This dimension does not include mold flash, protrusions, or gate burrs. Mold flash, protrusions, or gate burrs shall not exceed .006 [0.15] per side.
- This dimension does not include interlead flash.
- Reference JEDEC registration MS-012, variation AA.

EXAMPLE BOARD LAYOUT

D0008A

SOIC - 1.75 mm max height

SMALL OUTLINE INTEGRATED CIRCUIT



LAND PATTERN EXAMPLE
EXPOSED METAL SHOWN
SCALE:8X



SOLDER MASK DETAILS

4214825/C 02/2019

NOTES: (continued)

6. Publication IPC-7351 may have alternate designs.

7. Solder mask tolerances between and around signal pads can vary based on board fabrication site.

EXAMPLE STENCIL DESIGN

D0008A

SOIC - 1.75 mm max height

SMALL OUTLINE INTEGRATED CIRCUIT



SOLDER PASTE EXAMPLE
BASED ON .005 INCH [0.125 MM] THICK STENCIL
SCALE:8X

4214825/C 02/2019

NOTES: (continued)

8. Laser cutting apertures with trapezoidal walls and rounded corners may offer better paste release. IPC-7525 may have alternate design recommendations.
9. Board assembly site may have different recommendations for stencil design.

IMPORTANT NOTICE AND DISCLAIMER

TI PROVIDES TECHNICAL AND RELIABILITY DATA (INCLUDING DATASHEETS), DESIGN RESOURCES (INCLUDING REFERENCE DESIGNS), APPLICATION OR OTHER DESIGN ADVICE, WEB TOOLS, SAFETY INFORMATION, AND OTHER RESOURCES "AS IS" AND WITH ALL FAULTS, AND DISCLAIMS ALL WARRANTIES, EXPRESS AND IMPLIED, INCLUDING WITHOUT LIMITATION ANY IMPLIED WARRANTIES OF MERCHANTABILITY, FITNESS FOR A PARTICULAR PURPOSE OR NON-INFRINGEMENT OF THIRD PARTY INTELLECTUAL PROPERTY RIGHTS.

These resources are intended for skilled developers designing with TI products. You are solely responsible for (1) selecting the appropriate TI products for your application, (2) designing, validating and testing your application, and (3) ensuring your application meets applicable standards, and any other safety, security, or other requirements. These resources are subject to change without notice. TI grants you permission to use these resources only for development of an application that uses the TI products described in the resource. Other reproduction and display of these resources is prohibited. No license is granted to any other TI intellectual property right or to any third party intellectual property right. TI disclaims responsibility for, and you will fully indemnify TI and its representatives against, any claims, damages, costs, losses, and liabilities arising out of your use of these resources.

TI's products are provided subject to TI's Terms of Sale (www.ti.com/legal/termsofsale.html) or other applicable terms available either on ti.com or provided in conjunction with such TI products. TI's provision of these resources does not expand or otherwise alter TI's applicable warranties or warranty disclaimers for TI products.

Mailing Address: Texas Instruments, Post Office Box 655303, Dallas, Texas 75265
Copyright © 2020, Texas Instruments Incorporated