

TPS54917 3-V to 4-V Input, 9-A, Small Synchronous Buck Switcher With Integrated FETs (SWIFT™)

1 Features

- 13-mΩ MOSFET Switches for High Efficiency at 9-A Continuous Output
- Adjustable Output Voltage Down to 0.9 V With 1% Accuracy
- Externally Compensated for Design Flexibility
- Wide PWM Frequency: Fixed 350 kHz, 550 kHz, or Adjustable 280 kHz to 1.6 MHz
- Synchronizable to 1.6 MHz
- Load Protected by Peak Current Limit and Thermal Shutdown
- Small 3.5 mm x 7 mm Package and Similar Layout to TPS54910 Reduces Board Area and Total Cost
- SWIFT Documentation Application Notes, and SwitcherPro™ Software: www.ti.com/swift

2 Applications

- Low-Voltage, High-Density Systems With Power Distributed at 3.3 V
- Point-of-Load Regulation for High Performance DSPs, FPGAs, ASICs, and Microprocessors
- Broadband, Networking, and Optical Communications Infrastructure

3 Description

As a member of the SWIFT™ family of DC-DC regulators, the TPS54917 low-input voltage high-output current synchronous buck PWM converter offers the same features as the TPS54910 in a smaller package and higher switching frequency, which allows for a smaller total solution. Included on the substrate with the listed features are a true, high performance, voltage error amplifier that enables maximum performance under transient conditions and flexibility in choosing the output filter L and C components; an undervoltage lockout (UVLO) circuit to prevent start-up until the input voltage reaches 3 V; an internally and externally set slow-start circuit to limit in-rush currents; and a power good output useful for processor or logic reset, fault signaling, and supply sequencing.

The TPS54917 is available in a thermally enhanced 34-pin VQFN (RUV) PowerPAD™ package, which eliminates bulky heat sinks. TI provides evaluation modules and the SwitcherPro design software tool to aid in achieving high-performance power supply designs to meet aggressive equipment development cycles.

Device Information⁽¹⁾

PART NUMBER	PACKAGE	BODY SIZE (NOM)
TPS54917	VQFN (34)	3.50 mm x 7.00 mm

(1) For all available packages, see the orderable addendum at the end of the data sheet.

Simplified Schematic

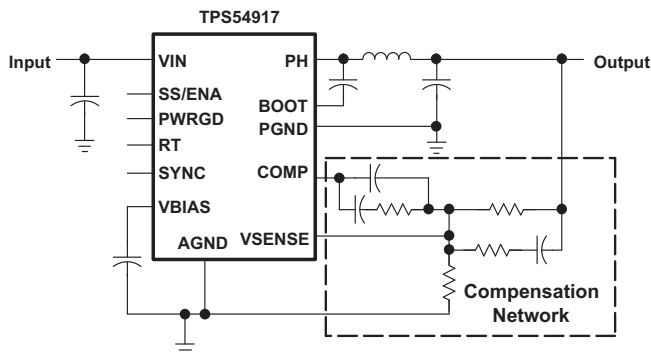

Efficiency at 700 kHz

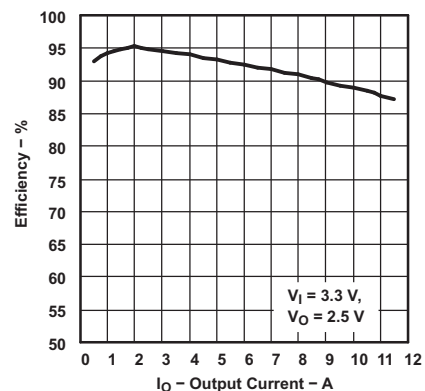

Table of Contents

1 Features	1	8.4 Device Functional Modes	13
2 Applications	1	9 Application and Implementation	14
3 Description	1	9.1 Application Information	14
4 Revision History	2	9.2 Typical Application	14
5 Device Comparison Table	3	10 Power Supply Recommendations	18
6 Pin Configuration and Functions	3	11 Layout	18
7 Specifications	5	11.1 Layout Guidelines	18
7.1 Absolute Maximum Ratings	5	11.2 Layout Example	19
7.2 ESD Ratings.....	5	11.3 Thermal Considerations	19
7.3 Recommended Operating Conditions	5	12 Device and Documentation Support	20
7.4 Thermal Information	5	12.1 Device Support.....	20
7.5 Electrical Characteristics.....	6	12.2 Receiving Notification of Documentation Updates	20
7.6 Typical Characteristics	8	12.3 Community Resources.....	20
8 Detailed Description	10	12.4 Trademarks	20
8.1 Overview	10	12.5 Electrostatic Discharge Caution.....	20
8.2 Functional Block Diagram	10	12.6 Glossary	20
8.3 Feature Description.....	11	13 Mechanical, Packaging, and Orderable Information	20

4 Revision History

NOTE: Page numbers for previous revisions may differ from page numbers in the current version.

Changes from Original (November 2008) to Revision A	Page
• Added <i>ESD Ratings</i> table, <i>Feature Description</i> section, <i>Device Functional Modes</i> , <i>Application and Implementation</i> section, <i>Power Supply Recommendations</i> section, <i>Layout</i> section, <i>Device and Documentation Support</i> section, and <i>Mechanical, Packaging, and Orderable Information</i> section	1
• Deleted <i>Ordering Information</i> table; see POA at the end of the data sheet.....	1
• Deleted <i>Package Dissipation Ratings</i> table.....	5
• Added <i>Thermal Information</i> table	5
• Changed RthetaJA value for RUV package from: 14.4°C/W to: 27.6°C/W	5
• Changed RthetaJC value for RUV package from: 0.5°C/W to: 14.8°C/W	5
• Changed 15 mΩ to 13 mΩ in two locations of the <i>Functional Block Diagram</i>	10
• Changed R1 value in <i>Application Circuit</i> From: 10 Ω To: 10 kΩ.....	14

5 Device Comparison Table

PART NUMBER	DESCRIPTION
TPS40000	DC-DC controller
TPS56300	DC-DC controller
TPS54619 and TPS54617	6-A converters
TPS54910	9-A converter

6 Pin Configuration and Functions

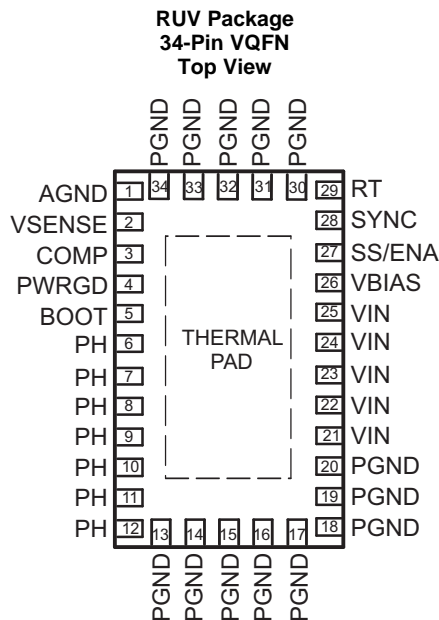

Pin Functions

PIN		I/O	DESCRIPTION
NAME	NO.		
AGND	1	—	Analog ground. Return for compensation network or output divider, slow-start capacitor, VBIAS capacitor, RT resistor and SYNC pin. Connect PowerPAD to AGND.
BOOT	5	O	Bootstrap input. 0.022- μ F to 0.1- μ F low-ESR capacitor connected from BOOT to PH generates floating drive for the high-side FET driver.
COMP	3	I/O	Error amplifier output. Connect frequency compensation network from COMP to VSENSE.
PH	6, 7, 8, 9, 10, 11, 12	O	Phase output. Junction of the internal high-side and low-side power MOSFETs, and output inductor.
PGND	13, 14, 15, 16, 17, 18, 19, 20, 30, 31, 32, 33, 34	—	Power ground. High current return for the low-side driver and power MOSFET. Connect PGND with large copper areas to the input and output supply returns, and negative terminals of the input and output capacitors. A single point connection to AGND is recommended.
PWRGD	4	O	Power good open-drain output. High when VSENSE \geq 90% V_{ref} , otherwise PWRGD is low. Note that output is low when SS/ENA is low or internal shutdown signal active.
RT	29	I	Frequency setting resistor input. Connect a resistor from RT to AGND to set the switching frequency, f_s .
SS/ENA	27	I/O	Slow-start/enable input or output. Dual function pin which provides logic input to enable or disable device operation and capacitor input to externally set the start-up time.
SYNC	28	I	Synchronization input. Dual function pin which provides logic input to synchronize to an external oscillator or pin select between two internally set switching frequencies. When used to synchronize to an external signal, a resistor must be connected to the RT pin.

Pin Functions (continued)

PIN		I/O	DESCRIPTION
NAME	NO.		
VBIAS	26	O	Internal bias regulator output. Supplies regulated voltage to internal circuitry. Bypass VBIAS pin to AGND pin with a high quality, low ESR, 0.1- μ F to 1- μ F ceramic capacitor.
VIN	21, 22, 23, 24, 25	I	Input supply for the power MOSFET switches and internal bias regulator. Bypass VIN pins to PGND pins close to device package with a high-quality, low-ESR 10- μ F ceramic capacitor.
VSENSE	2	I	Error amplifier inverting input. Connect to output voltage compensation network or output divider.

7 Specifications

7.1 Absolute Maximum Ratings

over operating free-air temperature range (unless otherwise noted)⁽¹⁾

		MIN	MAX	UNIT
Input voltage, V_I	SS/ENA, SYNC	-0.3	7	V
	RT	-0.3	6	
	VSENSE	-0.3	4	
	VIN	-0.3	4.5	
	BOOT	-0.3	10	
Output voltage, V_O	VBIAS, PWRGD, COMP	-0.6	7	V
	PH	-0.6	6	
	PH (transient < 10 ns)	-2		
Source current, I_O	PH	Internally limited		mA
	COMP, VBIAS	6		
Sink current, I_S	PH	16		A
	COMP	6		mA
	SS/ENA, PWRGD	10		
Voltage differential (AGND to PGND)		±0.3		V
Operating virtual junction temperature, T_J		-40	125	°C
Storage temperature, T_{stg}		-65	150	°C

- (1) Stresses beyond those listed under *Absolute Maximum Ratings* may cause permanent damage to the device. These are stress ratings only, which do not imply functional operation of the device at these or any other conditions beyond those indicated under *Recommended Operating Conditions*. Exposure to absolute-maximum-rated conditions for extended periods may affect device reliability.

7.2 ESD Ratings

		VALUE	UNIT
$V_{(ESD)}$ Electrostatic discharge	Human-body model (HBM), per ANSI/ESDA/JEDEC JS-001 ⁽¹⁾	±2000	V
	Charged-device model (CDM), per JEDEC specification JESD22-C101 ⁽²⁾	±500	

- (1) JEDEC document JEP155 states that 500-V HBM allows safe manufacturing with a standard ESD control process.
(2) JEDEC document JEP157 states that 250-V CDM allows safe manufacturing with a standard ESD control process.

7.3 Recommended Operating Conditions

over operating free-air temperature range (unless otherwise noted)

		MIN	MAX	UNIT
V_I	Input voltage	3	4	V
T_J	Operating junction temperature	-40	125	°C

7.4 Thermal Information

THERMAL METRIC ⁽¹⁾		TPS54917	UNIT
		RUV (VQFN)	
		34 PINS	
$R_{\theta JA}$	Junction-to-ambient thermal resistance	27.6	°C/W
$R_{\theta JC(top)}$	Junction-to-case (top) thermal resistance	14.8	°C/W
$R_{\theta JB}$	Junction-to-board thermal resistance	7.1	°C/W
Ψ_{JT}	Junction-to-top characterization parameter	0.2	°C/W
Ψ_{JB}	Junction-to-board characterization parameter	7.5	°C/W
$R_{\theta JC(bot)}$	Junction-to-case (bottom) thermal resistance	1.5	°C/W

- (1) For more information about traditional and new thermal metrics, see the [Semiconductor and IC Package Thermal Metrics](#) application report.

7.5 Electrical Characteristics

 $T_J = -40^{\circ}\text{C}$ to 125°C and $V_I = 3\text{ V}$ to 4 V (unless otherwise noted)

PARAMETER		TEST CONDITIONS	MIN	TYP	MAX	UNIT
SUPPLY VOLTAGE, VIN						
VIN input voltage			3		4	V
Quiescent current		$f_s = 350\text{ kHz}$, SYNC $\leq 0.8\text{ V}$, RT open, PH pin open		9.8	17	mA
		$f_s = 550\text{ kHz}$, SYNC $\geq 2.5\text{ V}$, RT open, PH pin open		14	23	
		Shutdown, SS/ENA = 0 V		1	1.4	
UNDERVOLTAGE LOCKOUT (UVLO)						
Start threshold voltage				2.95	3	V
Stop threshold voltage			2.7	2.8		
Hysteresis voltage				0.16		V
Rising and falling edge deglitch ⁽¹⁾				2.5		μs
BIAS VOLTAGE (VBIAS)						
V _O	Output voltage	$I_{(VBIAS)} = 0$	2.7	2.8	2.9	V
	Output current ⁽²⁾				100	μA
CUMULATIVE REFERENCE						
V _{ref}	Accuracy		0.882	0.891	0.9	V
REGULATION						
Line regulation ⁽¹⁾		$I_L = 4.5\text{ A}$, $f_s = 350\text{ kHz}$, $T_J = 85^{\circ}\text{C}$			0.07%	V
		$I_L = 4.5\text{ A}$, $f_s = 550\text{ kHz}$, $T_J = 85^{\circ}\text{C}$			0.07%	
Load regulation ⁽¹⁾		$I_L = 0\text{ A}$ to 9 A , $f_s = 350\text{ kHz}$, $T_J = 85^{\circ}\text{C}$			0.03%	A
		$I_L = 0\text{ A}$ to 9 A , $f_s = 550\text{ kHz}$, $T_J = 85^{\circ}\text{C}$			0.03%	
OSCILLATOR						
Internally set free-running frequency		SYNC $\leq 0.8\text{ V}$, RT open	280	350	420	kHz
		SYNC $\geq 2.5\text{ V}$, RT open	440	550	660	
Externally set free-running frequency		RT = 100 k Ω (1% resistor to AGND)	460	500	540	kHz
		RT = 27 k Ω (1% resistor to AGND)	1480	1600	1720	
High-level threshold voltage, SYNC			2.5			V
Low-level threshold voltage, SYNC					0.8	V
Pulse duration, SYNC ⁽¹⁾			50			
Frequency range, SYNC			330		1600	kHz
Ramp valley ⁽¹⁾				0.75		V
Ramp amplitude (peak-to-peak) ⁽¹⁾				1		V
Minimum controllable on time					160	ns
Maximum duty cycle			90%			
ERROR AMPLIFIER						
Error amplifier open loop voltage gain		1 k Ω COMP to AGND ⁽¹⁾	90	110		dB
Error amplifier unity gain bandwidth		Parallel 10 k Ω , 160 pF COMP to AGND ⁽¹⁾	3	5		MHz
Error amplifier common-mode input voltage range		Powered by internal LDO ⁽¹⁾	0		VBIAS	V
I _{IB}	Input bias current, VSENSE	VSENSE = V _{ref}		60	250	nA
V _O	Output voltage slew rate (symmetric), COMP ⁽¹⁾		1	1.4		V/ μs
PWM COMPARATOR						
PWM comparator propagation delay time		PWM comparator input to PH pin (excluding dead time), 10-mV overdrive ⁽¹⁾		70	85	ns

(1) Specified by design

(2) Static resistive loads only

Electrical Characteristics (continued)
 $T_J = -40^{\circ}\text{C}$ to 125°C and $V_I = 3\text{ V}$ to 4 V (unless otherwise noted)

PARAMETER	TEST CONDITIONS	MIN	TYP	MAX	UNIT
SLOW START/ENABLE (SS/ENA)					
Enable threshold voltage		0.82	1.2	1.4	V
Enable hysteresis voltage ⁽¹⁾			0.03		V
Falling edge deglitch ⁽¹⁾			2.5		μs
Internal slow-start time		2.6	3.35	4.1	ms
Charge current	SS/ENA = 0 V	3	5	8	μA
Discharge current	SS/ENA = 1.3 V, $V_I = 1.5\text{ V}$	1.5	2.3	4	mA
POWER GOOD (PWRGD)					
Power good threshold voltage	VSENSE falling		90		$\%V_{\text{ref}}$
Power good hysteresis voltage ⁽¹⁾			3		$\%V_{\text{ref}}$
Power good falling edge deglitch ⁽¹⁾			35		μs
Output saturation voltage	$I_{(\text{sink})} = 2.5\text{ mA}$		0.18	0.3	V
Leakage current	$V_I = 5.5\text{ V}$			1	μA
CURRENT LIMIT					
Current limit trip point	$V_I = 3.3\text{ V}^{(1)}$, output shorted	11	15		A
Current limit leading edge blanking time ⁽¹⁾			100		ns
Current limit total response time ⁽¹⁾			200		ns
THERMAL SHUTDOWN					
Thermal shutdown trip point ⁽¹⁾		135	150	165	$^{\circ}\text{C}$
Thermal shutdown hysteresis ⁽¹⁾			10		$^{\circ}\text{C}$
OUTPUT POWER MOSFETS					
$r_{\text{DS(on)}}$ Power MOSFET switches	$V_I = 3\text{ V}$		13.5	26	m Ω
	$V_I = 3.6\text{ V}$		12.5	24	

7.6 Typical Characteristics

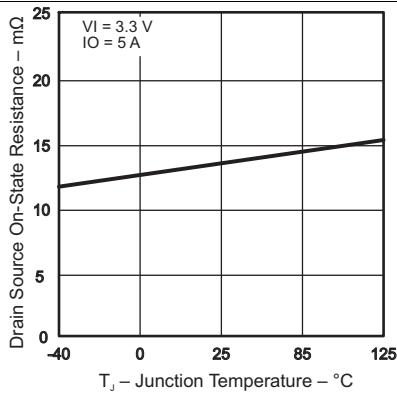

Figure 1. Drain-Source On-State Resistance vs Junction Temperature

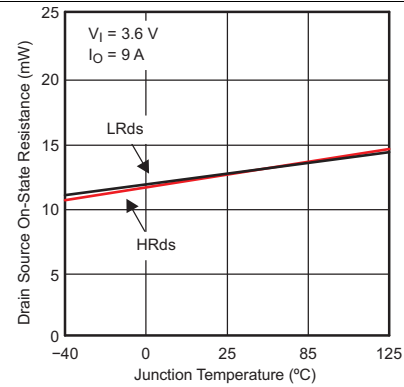

Figure 2. Drain-Source On-State Resistance vs Junction Temperature

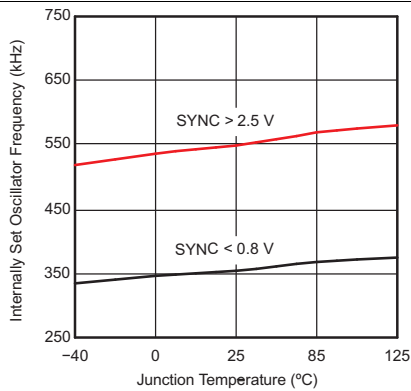

Figure 3. Internally Set Oscillator Frequency vs Junction Temperature

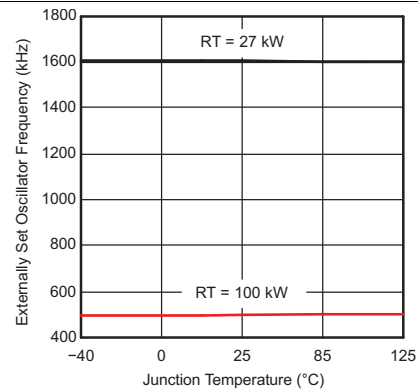

Figure 4. Externally Set Oscillator Frequency vs Junction Temperature

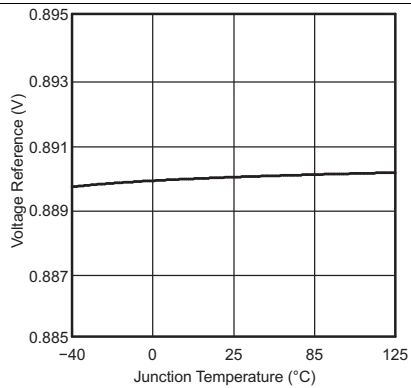

Figure 5. Voltage Reference vs Junction Temperature

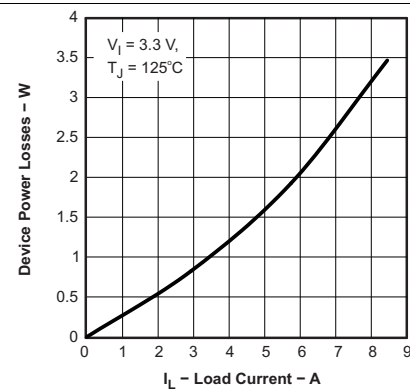

Figure 6. Device Power Losses vs Load Current

Typical Characteristics (continued)

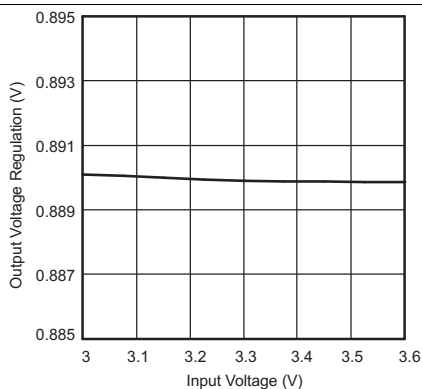

Figure 7. Output Voltage Regulation vs Input Voltage

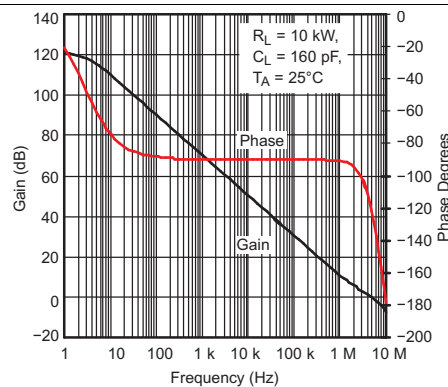

Figure 8. Error Amplifier vs Open Loop Response

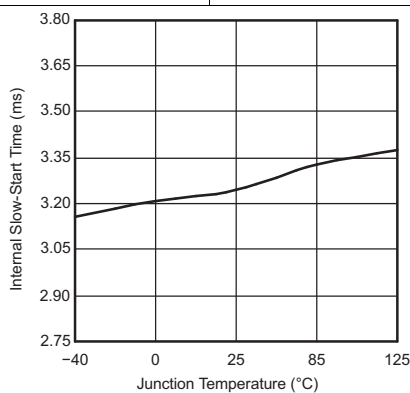

Figure 9. Internal Slow-Start Time vs Junction Temperature

8 Detailed Description

8.1 Overview

The TPS54917 is a low-input voltage, high-output current synchronous buck PWM converter. The device offers the same features as the TPS54910, but is in a smaller package. The switching frequency is adjustable and has a higher frequency limit of 1.6 MHz, which allows for a smaller total solution as the output inductor value can be reduced for the same AC ripple current. The switching frequency can be set externally with an RT timing resistor or programmed to internally set frequencies of 350 kHz or 550 kHz. Synchronization to an external clock is also supported. The TPS54917 features a high performance voltage error amplifier that enables maximum performance under transient conditions. The error amplifier supports external type 3 compensation. Type 3 compensation supports a wide variety of output filter types including ceramic and electrolytic type the output filter capacitors. An undervoltage lockout (UVLO) circuit to prevent start-up until the input voltage reaches 3 V. The TPS54917 slow-start time is set internally to 3.35 ms, or may be set externally with an optional capacitor to limit in-rush currents. A power good output is provided to allow the TPS54917 to control processor or logic reset, fault signaling, and power supply sequencing. The TPS54917 uses voltage mode control for the PWM modulation. Output current is internally limited on a cycle-by-cycle basis.

8.2 Functional Block Diagram

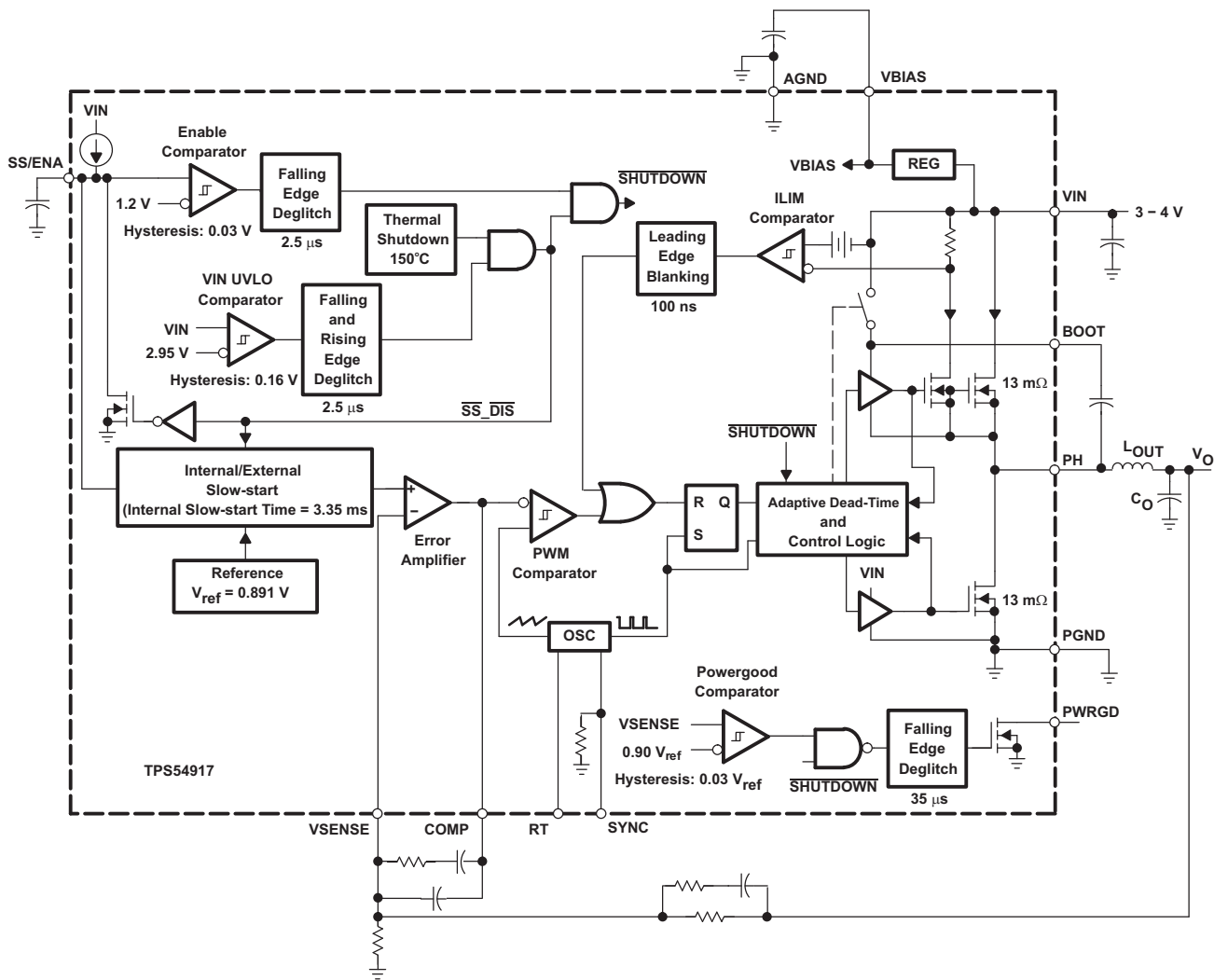

Copyright © 2016, Texas Instruments Incorporated

8.3 Feature Description

8.3.1 Undervoltage Lockout (UVLO)

The TPS54917 incorporates an undervoltage lockout circuit to keep the device disabled when the input voltage (VIN) is insufficient. During power up, internal circuits are held inactive until VIN exceeds the nominal UVLO threshold voltage of 2.95 V. Once the UVLO start threshold is reached, device start-up begins. The device operates until VIN falls below the nominal UVLO stop threshold of 2.8 V. Hysteresis in the UVLO comparator, and a 2.5-μs rising and falling edge deglitch circuit reduce the likelihood of shutting the device down due to noise on VIN.

8.3.2 Slow Start or Enable (SS/ENA)

The slow-start or enable pin provides two functions. First, the pin acts as an enable (shutdown) control by keeping the device turned off until the voltage exceeds the start threshold voltage of approximately 1.2 V. When SS/ENA exceeds the enable threshold, device start-up begins. The reference voltage fed to the error amplifier is linearly ramped up from 0 V to 0.891 V in 3.35 ms. Similarly, the converter output voltage reaches regulation in approximately 3.35 ms. Voltage hysteresis and a 2.5-μs falling edge deglitch circuit reduce the likelihood of triggering the enable due to noise.

The second function of the SS/ENA pin provides an external means of extending the slow-start time with a low-value capacitor connected between SS/ENA and AGND.

Adding a capacitor to the SS/ENA pin has two effects on start-up. First, a delay occurs between release of the SS/ENA pin and start-up of the output. The delay is proportional to the slow-start capacitor value and lasts until the SS/ENA pin reaches the enable threshold. The start-up delay is approximately [Equation 1](#).

$$t_d = C_{(SS)} \times \frac{1.2 \text{ V}}{5 \mu\text{A}} \quad (1)$$

Second, as the output becomes active, a brief ramp-up at the internal slow-start rate may be observed before the externally set slow-start rate takes control and the output rises at a rate proportional to the slow-start capacitor. The slow-start time set by the capacitor is approximately [Equation 2](#).

$$t_{(SS)} = C_{(SS)} \times \frac{0.7 \text{ V}}{5 \mu\text{A}} \quad (2)$$

The actual slow-start time is likely to be less than the above approximation due to the brief ramp-up at the internal rate.

8.3.3 VBIAS Regulator (VBIAS)

The VBIAS regulator provides internal analog and digital blocks with a stable supply voltage over variations in junction temperature and input voltage. A high-quality, low-ESR, ceramic bypass capacitor is required on the VBIAS pin. X7R or X5R grade dielectrics are recommended because their values are more stable over temperature. The bypass capacitor must be placed close to the VBIAS pin and returned to AGND.

External loading on VBIAS is allowed, with the caution that internal circuits require a minimum VBIAS of 2.7 V, and external loads on VBIAS with AC or digital switching noise may degrade performance. The VBIAS pin may be useful as a reference voltage for external circuits.

8.3.4 Voltage Reference

The voltage reference system produces a precise V_{ref} signal by scaling the output of a temperature stable band-gap circuit. During manufacture, the band-gap and scaling circuits are trimmed to produce 0.891 V at the output of the error amplifier, with the amplifier connected as a voltage follower. The trim procedure adds to the high precision regulation of the TPS54917 because it cancels offset errors in the scale and error amplifier circuits.

8.3.5 Oscillator and PWM Ramp

The oscillator frequency can be set to internally fixed values of 350 kHz or 550 kHz using the SYNC pin as a static digital input. If a different frequency of operation is required for the application, the oscillator frequency can be externally adjusted from 280 to 1600 kHz by connecting a resistor between the RT pin to ground and floating the SYNC pin. The switching frequency in MHz is approximated by [Equation 3](#).

Feature Description (continued)

$$F_{SW} = \frac{51000}{(R_T + 4400)}$$

where

- R is the resistance in Ohms from RT to AGND (3)

External synchronization of the PWM ramp is possible over the frequency range of 330 kHz to 1600 kHz by driving a synchronization signal into SYNC and connecting a resistor from RT to AGND. Choose a RT resistor that sets the free running frequency to 80% of the synchronization signal. [Table 1](#) summarizes the frequency selection configurations.

Table 1. Summary of the Frequency Selection Configurations

SWITCHING FREQUENCY	SYNC PIN	RT PIN
350 kHz, internally set	Float or AGND	Float
550 kHz, internally set	≥ 2.5 V	Float
Externally set 280 kHz to 1.6 MHz	Float	R = 27 k to 180 k
Externally synchronized frequency	Synchronization signal	R = RT value for 80% of external synchronization frequency

8.3.6 Error Amplifier

The high performance, wide bandwidth, voltage error amplifier sets the TPS54917 apart from most DC-DC converters. The user is given the flexibility to use a wide range of output L and C filter components to suit the particular application requirements. Type-2 or Type-3 compensation can be employed using external compensation components.

8.3.7 PWM Control

Signals from the error amplifier output, oscillator, and current limit circuit are processed by the PWM control logic. Referring to the internal block diagram, the control logic includes the PWM comparator, OR gate, PWM latch, and portions of the adaptive dead time and control-logic block. During steady-state operation below the current limit threshold, the PWM comparator output and oscillator pulse train alternately reset and set the PWM latch. Once the PWM latch is set, the low-side FET remains on for a minimum duration set by the oscillator pulse width. During this period, the PWM ramp discharges rapidly to its valley voltage. When the ramp begins to charge back up, the low-side FET turns off and high-side FET turns on. As the PWM ramp voltage exceeds the error amplifier output voltage, the PWM comparator resets the latch, thus turning off the high-side FET and turning on the low-side FET. The low-side FET remains on until the next oscillator pulse discharges the PWM ramp.

During transient conditions, the error amplifier output could be below the PWM ramp valley voltage or above the PWM peak voltage. If the error amplifier is high, the PWM latch is never reset, and the high-side FET remains on until the oscillator pulse signals the control logic to turn the high-side FET off and the low-side FET on. The device operates at its maximum duty cycle until the output voltage rises to the regulation setpoint, setting VSENSE to approximately the same voltage as VREF. If the error amplifier output is low, the PWM latch is continually reset and the high-side FET does not turn on. The low-side FET remains on until the VSENSE voltage decreases to a range that allows the PWM comparator to change states. The TPS54917 is capable of sinking current continuously until the output reaches the regulation setpoint.

If the current limit comparator trips for longer than 100 ns, the PWM latch resets before the PWM ramp exceeds the error amplifier output. The high-side FET turns off and low-side FET turns on to decrease the energy in the output inductor and consequently the output current. This process is repeated each cycle in which the current limit comparator is tripped.

8.3.8 Dead-Time Control and MOSFET Drivers

Adaptive dead-time control prevents shoot-through current from flowing in both N-channel power MOSFETs during the switching transitions by actively controlling the turnon times of the MOSFET drivers. The high-side driver does not turn on until the voltage at the gate of the low-side FET is below 2 V. While the low-side driver does not turn on until the voltage at the gate of the high-side MOSFET is below 2 V.

The high-side and low-side drivers are designed with 300-mA source and sink capability to drive the power MOSFETs gates. The low-side driver is supplied from VIN, while the high-side drive is supplied from the BOOT pin. A bootstrap circuit uses an external BOOT capacitor and an internal 2.5-Ω bootstrap switch connected between the VIN and BOOT pins. The integrated bootstrap switch improves drive efficiency and reduces external component count.

8.3.9 Overcurrent Protection

The cycle-by-cycle current limiting is achieved by sensing the current flowing through the high-side MOSFET and comparing this signal to a preset overcurrent threshold. The high-side MOSFET is turned off within 200 ns of reaching the current limit threshold. A 100-ns leading edge blanking circuit prevents current limit false tripping. Current limit detection occurs only when current flows from VIN to PH when sourcing current to the output filter. Load protection during current sink operation is provided by thermal shutdown.

8.3.10 Thermal Shutdown

The device uses the thermal shutdown to turn off the power MOSFETs and disable the controller if the junction temperature exceeds 150°C. The device is released from shutdown automatically when the junction temperature decreases to 10°C below the thermal shutdown trip point, and starts up under control of the slow-start circuit.

Thermal shutdown provides protection when an overload condition is sustained for several milliseconds. With a persistent fault condition, the device cycles continuously; starting up by control of the soft-start circuit, heating up due to the fault condition, and then shutting down upon reaching the thermal shutdown trip point. This sequence repeats until the fault condition is removed.

8.3.11 Power Good (PWRGD)

The power good circuit monitors for undervoltage conditions on VSENSE. If the voltage on VSENSE is 10% below the reference voltage, the open-drain PWRGD output is pulled low. PWRGD is also pulled low if VIN is less than the UVLO threshold or SS/ENA is low. When $V_{IN} \geq UVLO$ threshold, $SS/ENA \geq$ enable threshold, and $V_{SENSE} > 90\%$ of V_{ref} , the open-drain output of the PWRGD pin is high. A hysteresis voltage equal to 3% of V_{ref} and a 35-μs falling edge deglitch circuit prevent tripping of the power good comparator due to high-frequency noise.

8.4 Device Functional Modes

8.4.1 PWM Operation

TPS54917 is a synchronous buck converter. Normal operation occurs when V_{IN} is above 3 V and the SS/ENA pins is high to enable the device.

8.4.2 Standby Operation

TPS54917 can be placed in standby when the SS/ENA pin is set low, disabling the device.

Typical Application (continued)

Table 2. Application Circuit Specifications (continued)

PARAMETER		TEST CONDITIONS	MIN	TYP	MAX	UNIT
TRANSIENT RESPONSE						
ΔV_{OUT}	Change from load transient	$\Delta I_{OUT} = 4.5 \text{ A}$		50		mV
	Settling time	to 1% of V_{OUT}		0.5		ms
SYSTEMS CHARACTERISTICS						
f_{SW}	Switching frequency			1600		kHz

9.2.2 Detailed Design Procedure

9.2.2.1 Component Selection

The values for the components used in this design example were selected for best load transient response and small PCB area. Additional design information is available at www.ti.com.

9.2.2.2 Input Filter

The input voltage is a nominal 3.3 VDC. The input filter capacitors (C1 and C2) are 10- μF ceramic capacitors (MuRata). C12 is a 0.01- μF ceramic capacitor that provides high-frequency decoupling of the TPS54917 from the input supply. C1, C2, and C12 must be placed as close as possible to the device. Input ripple current is shared among C1, C2, and C12.

9.2.2.3 Feedback Circuit

The values for these components are selected to provide fast transient response times.

The resistor divider network of R1 and R2 sets the output voltage for the circuit at 1.8 V. R1 along with R6, R7, C5, C7, and C10 forms the loop compensation network for the circuit. For this design, a Type-3 topology is used. The feedback loop is compensated so that the unity gain frequency is approximately 40 kHz.

9.2.2.4 Operating Frequency

In the application circuit, RT is grounded through a 27.4-k Ω resistor to select the operating frequency of 1.6 MHz. To set a different frequency, place a 27-k Ω to 180-k Ω resistor between RT (pin 29) and analog ground or leave RT floating to select the default of 350 kHz. The switching frequency in MHz can be approximated using [Equation 4](#).

$$F_{SW} = \frac{51000}{(R_T + 4400)} \quad (4)$$

9.2.2.5 Output Filter

The output filter is composed of a 0.35- μH inductor and 2 \times 100- μF capacitors. The inductor is a dual-coil type (Coilcraft SLC7530-820ML) with the coils wired in series. The capacitors used are 100- μF , 6.3-V ceramic types with X5R dielectric.

9.2.3 Application Curves

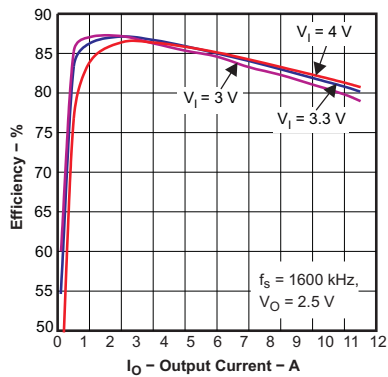

Figure 11. Efficiency vs Output Current

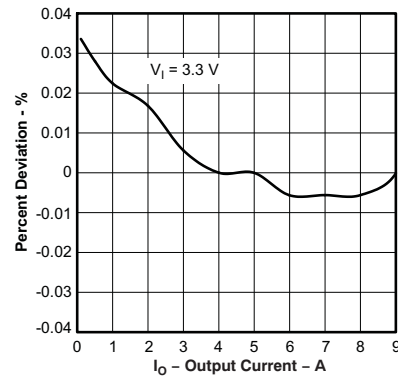

Figure 12. Load Regulation vs Output Current

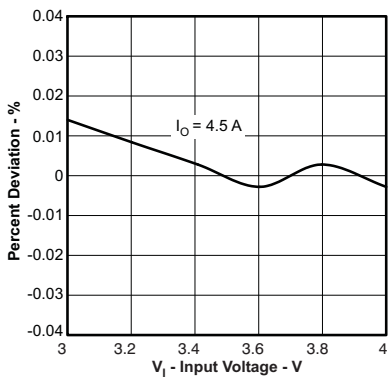
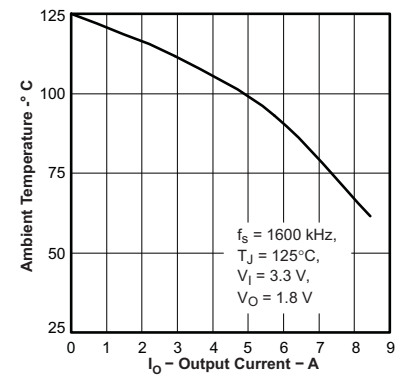

Figure 13. Line Regulation vs Input Voltage



Safe operating area is applicable to the test board conditions listed in [Thermal Information](#).

Figure 14. Ambient Temperature vs Load Current

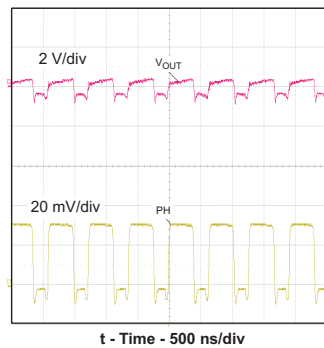

Figure 15. Output Ripple Voltage

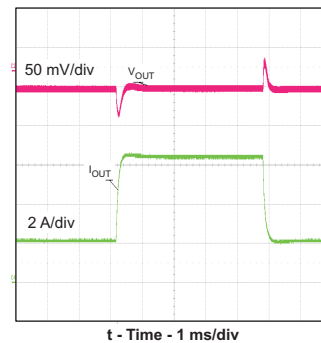

Figure 16. Transient Response

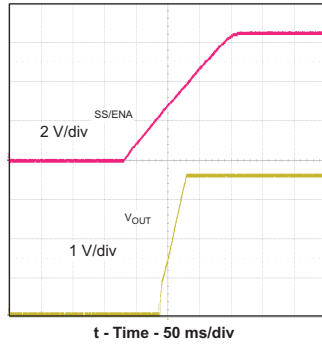

Figure 17. Slow-Start Timing

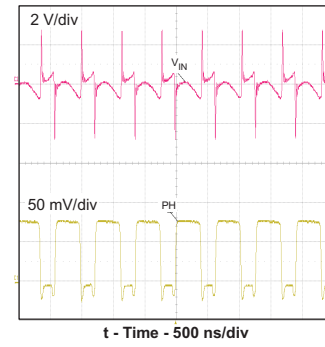

Figure 18. Input Ripple

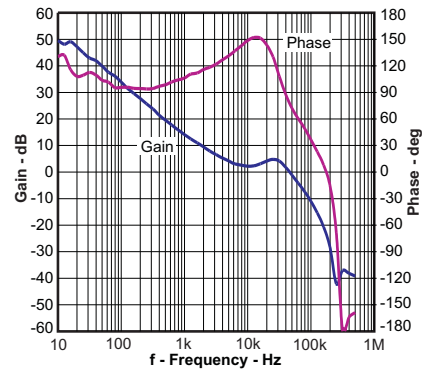

Figure 19. Closed-Loop Response

10 Power Supply Recommendations

The device is designed to operate from an input-voltage supply range between 3 V and 4 V. This input supply must be well regulated. If the input supply is placed more than a few inches from the converter, additional bulk capacitance may be required in addition to the ceramic bypass capacitors. An electrolytic capacitor with a value of 100 μ F is a typical choice.

11 Layout

11.1 Layout Guidelines

[Figure 20](#) shows a generalized PCB layout guide for the TPS54917. The VIN pins must be connected together on the printed-circuit board (PCB) and bypassed with a low-ESR ceramic bypass capacitors. Take care to minimize the loop area formed by the bypass capacitor connections, the VIN pins, and the TPS54917 ground pins. The minimum recommended bypass capacitance is 10- μ F ceramic with a X5R or X7R dielectric and the optimum placement is closest to the VIN pins and the PGND pins.

The TPS54917 has two internal grounds (analog and power). The analog ground ties to all of the noise-sensitive signals, while the power ground ties to the noisier power signals. Noise injected between the two grounds can degrade the performance of the TPS54917, particularly at higher output currents. Ground noise on an analog ground plane can also cause problems with some of the control and bias signals. For these reasons, separate analog and power ground traces are recommended. There must be an area of ground on the top layer directly under the IC, with an exposed area for connection to the PowerPAD. Use vias to connect this ground area to any internal ground planes. Use additional vias at the ground side of the input and output filter capacitors as well. The AGND and PGND pins must be tied to the PCB ground by connecting them to the ground area under the device as shown. Use a separate wide traces for the analog ground signal path. This analog ground must be used for the voltage setpoint divider, timing resistor RT, slow-start capacitor, and bias capacitor grounds. Connect this trace the top-side ground area near AGND (Pin 1).

The PH pins must be tied together and routed to the output inductor. Because the PH connection is the switching node, the inductor must be placed very close to the PH pins and the area of the PCB conductor minimized to prevent excessive capacitive coupling.

Connect the boot capacitor between the phase node and the BOOT pin as shown. Keep the boot capacitor close to the IC and minimize the conductor trace lengths.

Connect the output filter capacitor(s) as shown between the VOUT trace and PGND. It is important to keep the loop formed by the PH pins, Lout, Cout and PGND as small as practical.

Place the compensation components from the VOUT trace to the VSENSE and COMP pins. Do not place these components too close to the PH trace. Due to the size of the IC package and the device pinout, the components has to be routed somewhat close, but maintain as much separation as possible while still keeping the layout compact.

Connect the bias capacitor from the VBIAS pin to analog ground using the isolated analog ground trace. If a slow-start capacitor or RT resistor is used, or if the SYNC pin is used to select 350-kHz operating frequency, connect them to this trace as well.

11.1.1 Estimated Circuit Area

The estimated printed-circuit board area for the components used in the design of [Figure 10](#) is 0.55 in². This area does not include test points or connectors.

11.2 Layout Example

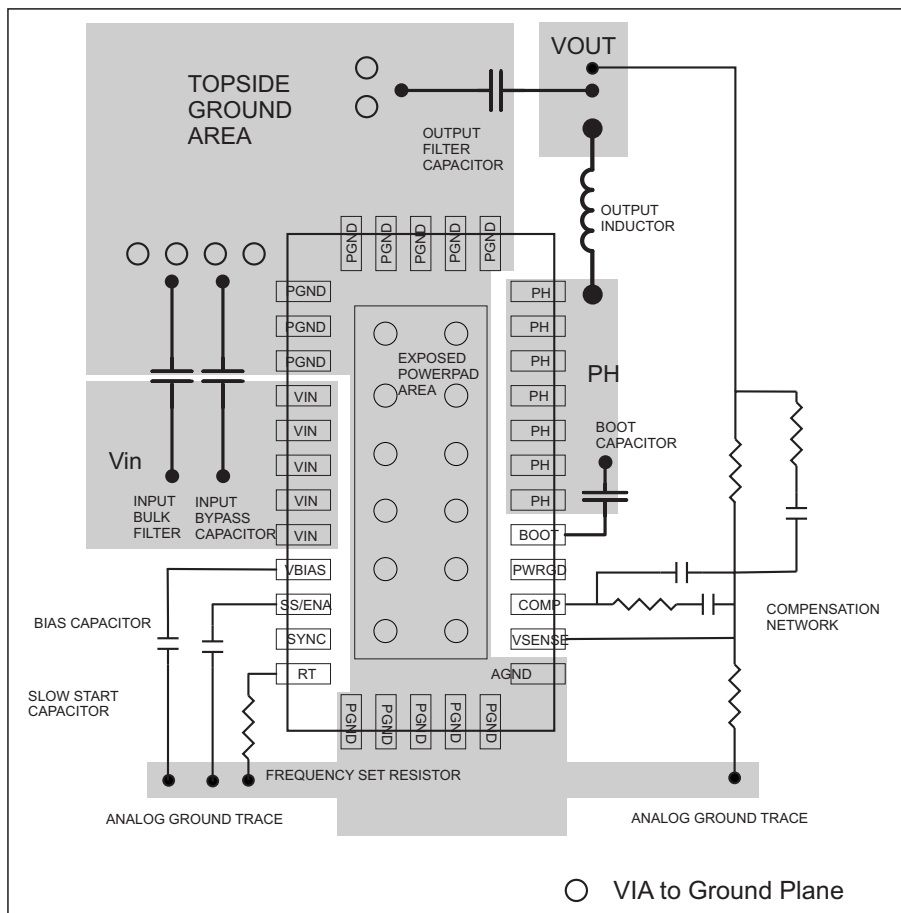

Figure 20. TPS54917 PCB Layout

11.3 Thermal Considerations

The RUV package has been chosen to enable a thermal management scheme, allowing a ground plane to extend beyond both ends of the package.

For operation at full rated load current, the analog ground plane must provide an adequate heat dissipating area. A 3-inch by 3-inch plane of 1-ounce copper is recommended, though not mandatory, depending on ambient temperature and airflow. Most applications have larger areas of internal ground plane available, and the PowerPAD must be connected to the largest area available. Additional areas on the top or bottom layers also help dissipate heat, and any area available must be used when 6 A or greater operation is desired. Connection from the exposed area of the PowerPAD to the analog ground plane layer must be made using 0.013-inch diameter vias to avoid solder wicking through the vias.

12 vias must be in the PowerPAD area placed under the device package. Additional vias beyond the twelve recommended may be added in the ground area outside the package footprint to enhance thermal performance. The size of the vias outside of the package, not in the exposed thermal pad area, can be increased to 0.018.

12 Device and Documentation Support

12.1 Device Support

12.1.1 Developmental Support

For developmental support, see the following:

www.ti.com/swift

12.2 Receiving Notification of Documentation Updates

To receive notification of documentation updates, navigate to the device product folder on ti.com. In the upper right corner, click on *Alert me* to register and receive a weekly digest of any product information that has changed. For change details, review the revision history included in any revised document.

12.3 Community Resources

The following links connect to TI community resources. Linked contents are provided "AS IS" by the respective contributors. They do not constitute TI specifications and do not necessarily reflect TI's views; see TI's [Terms of Use](#).

TI E2E™ Online Community *TI's Engineer-to-Engineer (E2E) Community*. Created to foster collaboration among engineers. At e2e.ti.com, you can ask questions, share knowledge, explore ideas and help solve problems with fellow engineers.

Design Support *TI's Design Support* Quickly find helpful E2E forums along with design support tools and contact information for technical support.

12.4 Trademarks

SwitcherPro, SWIFT, PowerPAD, E2E are trademarks of Texas Instruments. All other trademarks are the property of their respective owners.

12.5 Electrostatic Discharge Caution



These devices have limited built-in ESD protection. The leads should be shorted together or the device placed in conductive foam during storage or handling to prevent electrostatic damage to the MOS gates.

12.6 Glossary

[SLYZ022](#) — *TI Glossary*.

This glossary lists and explains terms, acronyms, and definitions.

13 Mechanical, Packaging, and Orderable Information

The following pages include mechanical, packaging, and orderable information. This information is the most current data available for the designated devices. This data is subject to change without notice and revision of this document. For browser-based versions of this data sheet, refer to the left-hand navigation.

PACKAGING INFORMATION

Orderable Device	Status (1)	Package Type	Package Drawing	Pins	Package Qty	Eco Plan (2)	Lead finish/ Ball material (6)	MSL Peak Temp (3)	Op Temp (°C)	Device Marking (4/5)	Samples
TPS54917RUVR	ACTIVE	VQFN	RUV	34	3000	RoHS & Green	NIPDAU	Level-3-260C-168 HR	-40 to 125	54917	Samples
TPS54917RUVT	ACTIVE	VQFN	RUV	34	250	RoHS & Green	NIPDAU	Level-3-260C-168 HR	-40 to 125	54917	Samples

(1) The marketing status values are defined as follows:

ACTIVE: Product device recommended for new designs.

LIFEBUY: TI has announced that the device will be discontinued, and a lifetime-buy period is in effect.

NRND: Not recommended for new designs. Device is in production to support existing customers, but TI does not recommend using this part in a new design.

PREVIEW: Device has been announced but is not in production. Samples may or may not be available.

OBSOLETE: TI has discontinued the production of the device.

(2) **RoHS:** TI defines "RoHS" to mean semiconductor products that are compliant with the current EU RoHS requirements for all 10 RoHS substances, including the requirement that RoHS substance do not exceed 0.1% by weight in homogeneous materials. Where designed to be soldered at high temperatures, "RoHS" products are suitable for use in specified lead-free processes. TI may reference these types of products as "Pb-Free".

RoHS Exempt: TI defines "RoHS Exempt" to mean products that contain lead but are compliant with EU RoHS pursuant to a specific EU RoHS exemption.

Green: TI defines "Green" to mean the content of Chlorine (Cl) and Bromine (Br) based flame retardants meet JS709B low halogen requirements of <=1000ppm threshold. Antimony trioxide based flame retardants must also meet the <=1000ppm threshold requirement.

(3) MSL, Peak Temp. - The Moisture Sensitivity Level rating according to the JEDEC industry standard classifications, and peak solder temperature.

(4) There may be additional marking, which relates to the logo, the lot trace code information, or the environmental category on the device.

(5) Multiple Device Markings will be inside parentheses. Only one Device Marking contained in parentheses and separated by a "~" will appear on a device. If a line is indented then it is a continuation of the previous line and the two combined represent the entire Device Marking for that device.

(6) Lead finish/Ball material - Orderable Devices may have multiple material finish options. Finish options are separated by a vertical ruled line. Lead finish/Ball material values may wrap to two lines if the finish value exceeds the maximum column width.

Important Information and Disclaimer:The information provided on this page represents TI's knowledge and belief as of the date that it is provided. TI bases its knowledge and belief on information provided by third parties, and makes no representation or warranty as to the accuracy of such information. Efforts are underway to better integrate information from third parties. TI has taken and continues to take reasonable steps to provide representative and accurate information but may not have conducted destructive testing or chemical analysis on incoming materials and chemicals. TI and TI suppliers consider certain information to be proprietary, and thus CAS numbers and other limited information may not be available for release.

In no event shall TI's liability arising out of such information exceed the total purchase price of the TI part(s) at issue in this document sold by TI to Customer on an annual basis.

TAPE AND REEL INFORMATION

QUADRANT ASSIGNMENTS FOR PIN 1 ORIENTATION IN TAPE

*All dimensions are nominal

Device	Package Type	Package Drawing	Pins	SPQ	Reel Diameter (mm)	Reel Width W1 (mm)	A0 (mm)	B0 (mm)	K0 (mm)	P1 (mm)	W (mm)	Pin1 Quadrant
TPS54917RUVR	VQFN	RUV	34	3000	330.0	16.4	3.85	7.35	1.2	8.0	16.0	Q1
TPS54917RUVT	VQFN	RUV	34	250	180.0	16.4	3.85	7.35	1.2	8.0	16.0	Q1

TAPE AND REEL BOX DIMENSIONS

*All dimensions are nominal

Device	Package Type	Package Drawing	Pins	SPQ	Length (mm)	Width (mm)	Height (mm)
TPS54917RUVR	VQFN	RUV	34	3000	853.0	449.0	35.0
TPS54917RUVT	VQFN	RUV	34	250	210.0	185.0	35.0

RUV (R-PVQFN-N34)

PLASTIC QUAD FLATPACK NO-LEAD

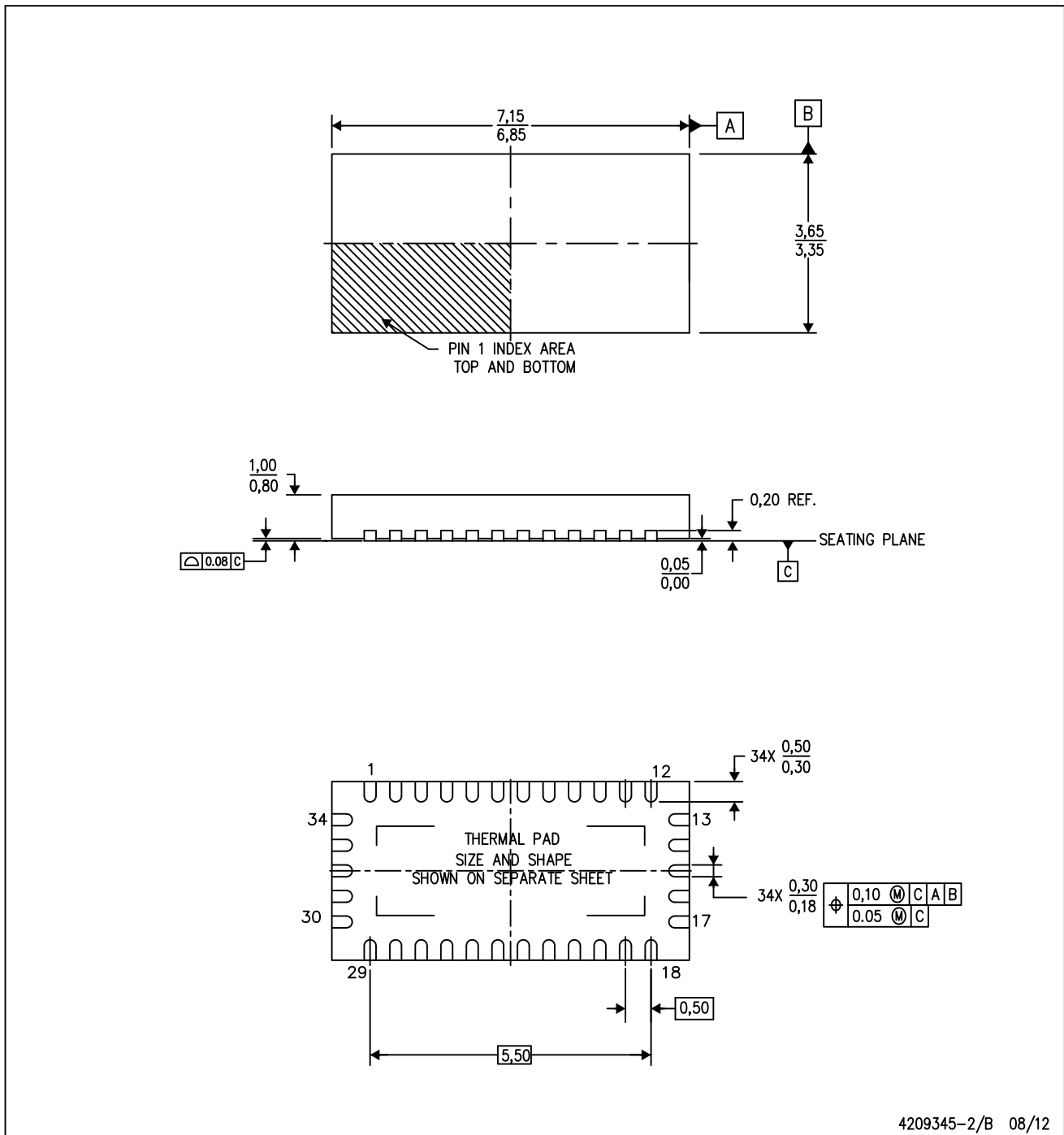

- NOTES:
- All linear dimensions are in millimeters. Dimensioning and tolerancing per ASME Y14.5M-1994.
 - This drawing is subject to change without notice.
 - Quad Flatpack, No-leads (QFN) package configuration.
 - The package thermal pad must be soldered to the board for thermal and mechanical performance.
 - See the additional figure in the Product Data Sheet for details regarding the exposed thermal pad features and dimensions.
 - Falls within JEDEC MO-220.

THERMAL PAD MECHANICAL DATA

RUV (S-PVQFN-N34)

PLASTIC QUAD FLATPACK NO-LEAD

THERMAL INFORMATION

This package incorporates an exposed thermal pad that is designed to be attached directly to an external heatsink. The thermal pad must be soldered directly to the printed circuit board (PCB). After soldering, the PCB can be used as a heatsink. In addition, through the use of thermal vias, the thermal pad can be attached directly to the appropriate copper plane shown in the electrical schematic for the device, or alternatively, can be attached to a special heatsink structure designed into the PCB. This design optimizes the heat transfer from the integrated circuit (IC).

For information on the Quad Flatpack No-Lead (QFN) package and its advantages, refer to Application Report, QFN/SON PCB Attachment, Texas Instruments Literature No. SLUA271. This document is available at www.ti.com.

The exposed thermal pad dimensions for this package are shown in the following illustration.

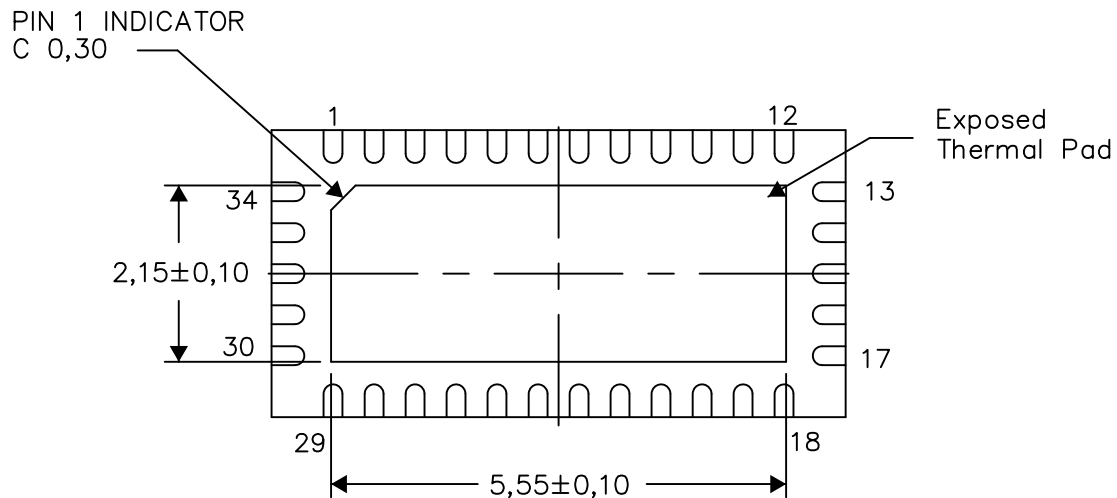

Bottom View

Exposed Thermal Pad Dimensions

4209552-2/E 06/13

NOTE: All linear dimensions are in millimeters

RUV (R-PVQFN-N34)

PLASTIC QUAD FLATPACK NO-LEAD

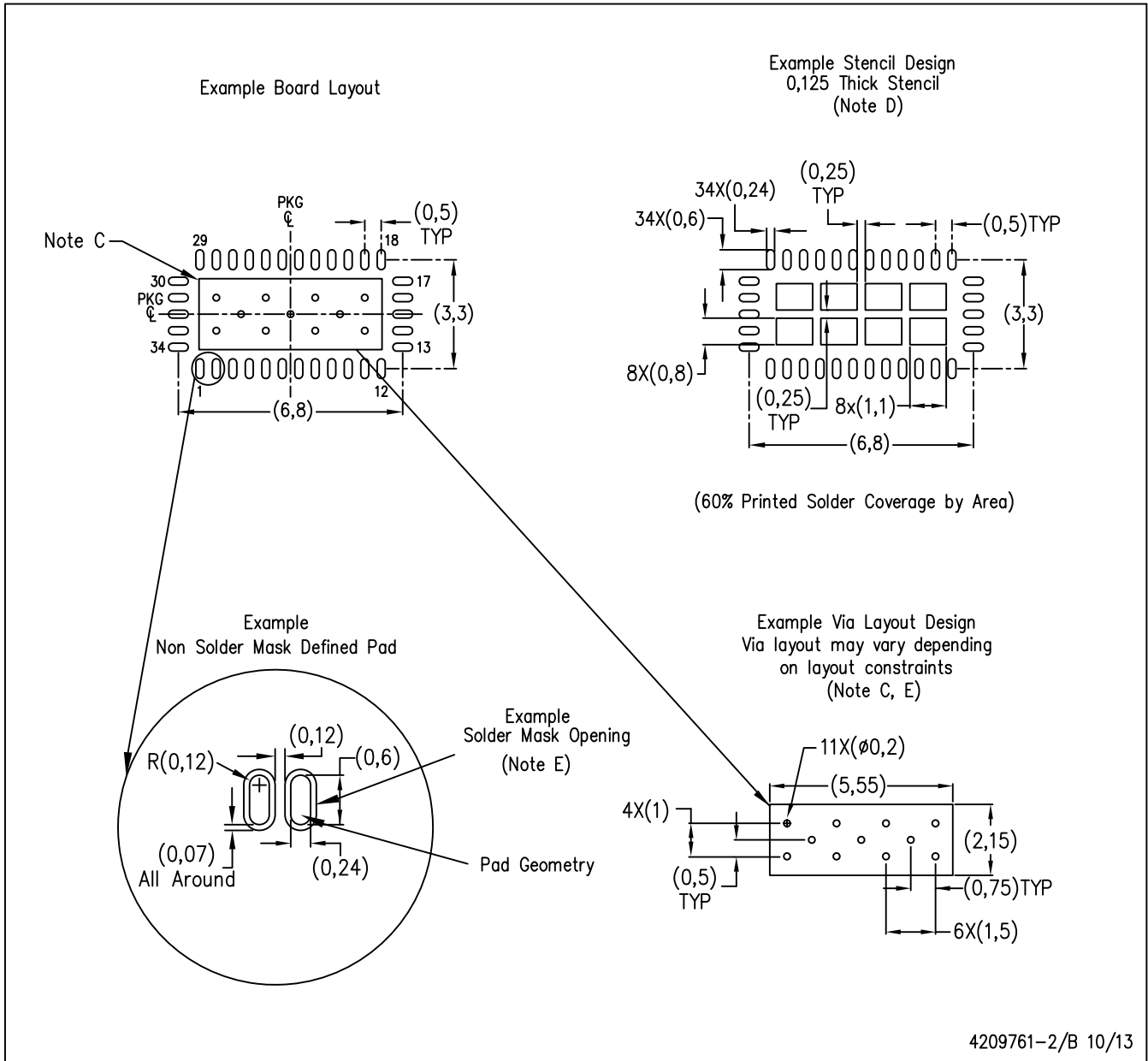

- NOTES:
- All linear dimensions are in millimeters.
 - This drawing is subject to change without notice.
 - This package is designed to be soldered to a thermal pad on the board. Refer to Application Note, Quad Flat-Pack Packages, Texas Instruments Literature No. SLUA271, and also the Product Data Sheets for specific thermal information, via requirements, and recommended board layout. These documents are available at www.ti.com <<http://www.ti.com>>.
 - Laser cutting apertures with trapezoidal walls and also rounding corners will offer better paste release. Customers should contact their board assembly site for stencil design recommendations. Refer to IPC 7525 for stencil design considerations.
 - Customers should contact their board fabrication site for recommended solder mask tolerances and via tenting recommendations for vias placed in the thermal pad.

IMPORTANT NOTICE AND DISCLAIMER

TI PROVIDES TECHNICAL AND RELIABILITY DATA (INCLUDING DATASHEETS), DESIGN RESOURCES (INCLUDING REFERENCE DESIGNS), APPLICATION OR OTHER DESIGN ADVICE, WEB TOOLS, SAFETY INFORMATION, AND OTHER RESOURCES "AS IS" AND WITH ALL FAULTS, AND DISCLAIMS ALL WARRANTIES, EXPRESS AND IMPLIED, INCLUDING WITHOUT LIMITATION ANY IMPLIED WARRANTIES OF MERCHANTABILITY, FITNESS FOR A PARTICULAR PURPOSE OR NON-INFRINGEMENT OF THIRD PARTY INTELLECTUAL PROPERTY RIGHTS.

These resources are intended for skilled developers designing with TI products. You are solely responsible for (1) selecting the appropriate TI products for your application, (2) designing, validating and testing your application, and (3) ensuring your application meets applicable standards, and any other safety, security, or other requirements. These resources are subject to change without notice. TI grants you permission to use these resources only for development of an application that uses the TI products described in the resource. Other reproduction and display of these resources is prohibited. No license is granted to any other TI intellectual property right or to any third party intellectual property right. TI disclaims responsibility for, and you will fully indemnify TI and its representatives against, any claims, damages, costs, losses, and liabilities arising out of your use of these resources.

TI's products are provided subject to TI's Terms of Sale (www.ti.com/legal/termsofsale.html) or other applicable terms available either on ti.com or provided in conjunction with such TI products. TI's provision of these resources does not expand or otherwise alter TI's applicable warranties or warranty disclaimers for TI products.

Mailing Address: Texas Instruments, Post Office Box 655303, Dallas, Texas 75265
Copyright © 2020, Texas Instruments Incorporated