

DRV8873-Q1 汽车类 H 桥电机驱动器

1 特性

- 符合面向汽车应用的 AEC-Q100 标准
 - 器件温度等级 1: -40°C 至 $+125^{\circ}\text{C}$, T_A
- H 桥电机驱动器
 - 驱动一个直流电机、一个步进电机绕组或电磁阀负载
- 4.5V 至 38V 工作电压范围
- 10A 峰值电流驱动能力
- 低 HS + LS $R_{DS(ON)}$
 - $T_J = 25^{\circ}\text{C}$ 且电压为 13.5V 时为 150m Ω
 - $T_J = 150^{\circ}\text{C}$ 且电压为 13.5V 时为 250m Ω
- 用于输出电流检测的电流镜
- 可配置控制接口
 - PH/EN
 - PWM (IN1/IN2)
 - 独立半桥控制
- 支持 1.8V、3.3V 和 5V 逻辑输入
- SPI 或硬件接口选项
- 低功耗睡眠模式 (10 μA)
- 小型封装和外形尺寸
 - 24 引脚散热薄型小外形尺寸 (HTSSOP) PowerPAD™IC 封装
- 保护 特性
 - VM 欠压闭锁 (UVLO)
 - 电荷泵欠压 (CPUV)
 - 过流保护 (OCP)
 - 输出对电池短路和接地短路保护
 - 开路负载检测
 - 热关断 (TSD)
 - 故障状况输出 (nFAULT/SPI)

2 应用

- 电子节流控制
- 废气再循环
- 侧后视镜倾斜
- 电子换挡器
- 气流转向阀控制

3 说明

DRV8873-Q1 器件是用于驱动汽车应用中的刷式直流电机的集成式驱动器 IC。两个逻辑输入控制 H 桥驱动器，该驱动器包含四个能够以高达 10A 的峰值电流双向驱动电机的 N 沟道 MOSFET。该器件由单一电源供电，支持 4.5V 至 38V 的宽输入电源范围。

该器件可通过 PH/EN 或 PWM 接口轻松连接至控制器电路。或者，可以使用独立的半桥控制来驱动两个电磁阀负载。

控制器可利用电流镜来监控负载电流。该电流镜接近于流经高侧 FET 的电流，并且不需要使用高功率电阻器来检测电流。

提供了低功耗睡眠模式，以通过关断大量内部电路来实现极低的静态电流消耗。还提供了用于欠压锁定、电荷泵故障、过流保护、短路保护、开路负载检测和过热的内部保护功能。可通过 nFAULT 引脚和 SPI 寄存器来指示故障状况。

器件信息⁽¹⁾

器件型号	封装	封装尺寸 (标称值)
DRV8873-Q1	HTSSOP (24)	7.70mm x 4.40mm

(1) 如需了解所有可用封装，请参阅数据表末尾的可订购产品附录。

简化原理图

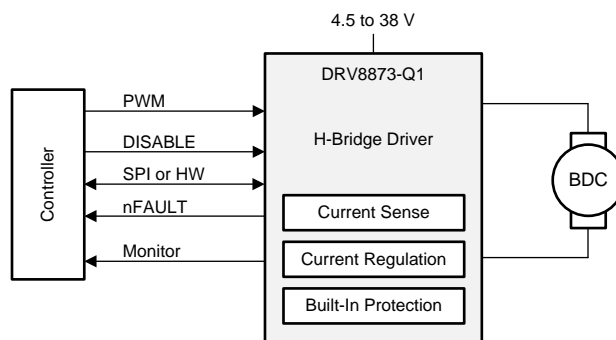

目录

1	特性	1	7.5	Programming.....	30
2	应用	1	7.6	Register Maps	35
3	说明	1	8	Application and Implementation	40
4	修订历史记录	2	8.1	Application Information.....	40
5	Pin Configuration and Functions	3	8.2	Typical Application	40
6	Specifications.....	4	9	Power Supply Recommendations.....	46
6.1	Absolute Maximum Ratings	4	9.1	Bulk Capacitance Sizing	46
6.2	ESD Ratings.....	5	10	Layout.....	47
6.3	Recommended Operating Conditions.....	5	10.1	Layout Guidelines	47
6.4	Thermal Information	5	10.2	Layout Example	47
6.5	Electrical Characteristics.....	5	11	器件和文档支持	48
6.6	SPI Timing Requirements	8	11.1	文档支持	48
6.7	Typical Characteristics	9	11.2	接收文档更新通知	48
7	Detailed Description	10	11.3	社区资源	48
7.1	Overview	10	11.4	商标	48
7.2	Functional Block Diagram	11	11.5	静电放电警告.....	48
7.3	Feature Description.....	13	11.6	术语表	48
7.4	Device Functional Modes.....	29	12	机械、封装和可订购信息.....	48

4 修订历史记录

注：之前版本的页码可能与当前版本有所不同。

Changes from Original (October 2017) to Revision A

Page

• 已更改 将状态从预告信息更改成了生产数据	1
------------------------------	----------

5 Pin Configuration and Functions

**DRV8873H-Q1 PWP PowerPAD Package
24-Pin HTSSOP
Top View**

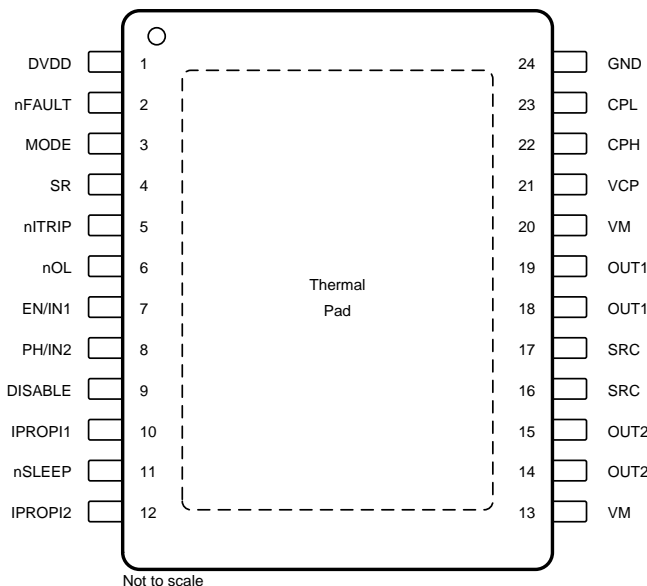

**DRV8873S-Q1 PWP PowerPAD Package
24-Pin HTSSOP
Top View**

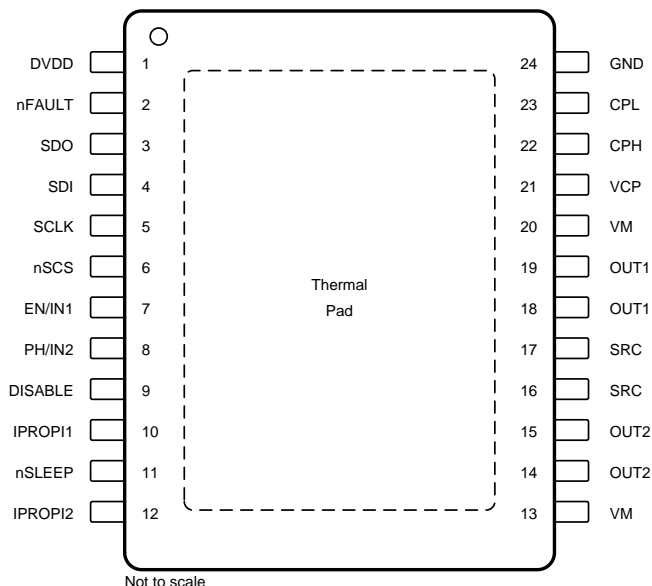

Pin Functions

NAME	PIN NO.		TYPE ⁽¹⁾	DESCRIPTION
	DRV8873H-Q1	DRV8873S-Q1		
CPH	22	22	PWR	Charge pump switching node. Connect a X7R capacitor with a value of 47 nF between the CPH and CPL pins.
CPL	23	23	PWR	Charge pump switching node. Connect a X7R capacitor with a value of 47 nF between the CPH and CPL pins.
DVDD	1	1	PWR	Digital regulator. This pin is the 5-V internal digital-supply regulator. Bypass this pin to GND with a 6.3-V, 1-μF ceramic capacitor.
EN/IN1	7	7	I	Control Inputs. For details, see the Control Modes section. This pin has an internal pulldown resistor to GND.
DISABLE	9	9	I	Bridge disable input. A logic high on this pin disables the H-bridge Hi-Z. Internal pullup to DVDD.
GND	24	24	PWR	Ground pin
IPROPI1	10	10	O	High-side FET current. The analog current proportional to the current flowing in the half bridge.
IPROPI2	12	12	O	High-side FET current. The analog current proportional to the current flowing in the half bridge.
nITRIP	5	—	I	Internal current-regulation control pin (ITRIP). To enable the ITRIP feature, do not connect this pin (or tie it to GND). To disable the ITRIP feature, connect this pin to the DVDD pin.
nOL	6	—	I	Open-load diagnostic control pin. To run the open-load diagnostic at power up, tie it to ground. Connect it to DVDD, open-load diagnostic will be disabled.
MODE	3	—	I	Input mode pin. Sets the PH/EN, PWM, or independent-PWM mode.
OUT1	18	18	O	Half-bridge output 1. Connect this pin to the motor or load.
OUT1	19	19	O	Half-bridge output 1. Connect this pin to the motor or load.
OUT2	14	14	O	Half-bridge output 2. Connect this pin to the motor or load.
OUT2	15	15	O	Half-bridge output 2. Connect this pin to the motor or load.

(1) I = input, O = output, PWR = power, NC = no connect, OD = open-drain output, PP = push-pull output

Pin Functions (continued)

NAME	PIN		TYPE ⁽¹⁾	DESCRIPTION
	NO.			
	DRV8873H-Q1	DRV8873S-Q1		
PH/IN2	8	8	I	Control inputs. For details, see the Control Modes section. This pin has an internal pulldown resistor to GND.
SCLK	—	5	I	Serial clock input. Serial data is shifted out and captured on the corresponding rising and falling edge on this pin.
SDI	—	4	I	Serial data input. Data is captured on the falling edge of the SCLK pin.
SDO	—	3	PP	Serial data output. Data is shifted out on the rising edge of the SCLK pin. This is a push-pull output.
SR	4	—	I	Slew rate adjust. This pin sets the slew rate of the H-bridge outputs.
SRC	16	16	O	Power FET source. Tie this pin to GND through a low-impedance path.
SRC	17	17	O	Power FET source. Tie this pin to GND through a low-impedance path.
VCP	21	21	PWR	Charge pump output. Connect a 16-V, 1- μ F ceramic capacitor from this pin to the VM supply.
VM	13	13	PWR	Power supply. This pin is the motor supply voltage. Bypass this pin to GND with a 0.1- μ F ceramic capacitor and a bulk capacitor.
VM	20	20	PWR	Power supply. This pin is the motor supply voltage. Bypass this pin to GND with a 0.1- μ F ceramic capacitor and a bulk capacitor.
nFAULT	2	2	OD	Fault indication pin. This pin is pulled logic low with a fault condition. This open-drain output requires an external pullup resistor.
nSCS	—	6	I	Serial chip select. An active low on this pin enables the serial interface communications. Internal pullup to nSLEEP.
nSLEEP	11	11	I	Sleep input. To enter a low-power sleep mode, set this pin logic low.

6 Specifications

6.1 Absolute Maximum Ratings

 over operating free-air temperature range (unless otherwise noted)⁽¹⁾

			MIN	MAX	UNIT
	Power supply voltage	VM	-0.3	40	V
	Charge pump voltage	VCP, CPH	-0.3	$V_{VM} + 5.7$	V
	Charge pump switching pin	CPL	-0.3	V_{VM}	V
	Internal logic regulator voltage	DVDD	-0.3	5.7	V
	Digital pin voltage	EN/IN1, PH/IN2, nSLEEP, DISABLE, nFAULT, MODE, SR, SCLK, SDI, SDO, nSCS	-0.3	5.7	V
V_{TRIP}	Analog pin voltage	IPROPI1, IPROPI2	0	5.5	V
V_{SRC}	H-Bridge source pin voltage		-0.3	0.3	V
	Phase node pin voltage	OUTx	$V_{SRC} - 1$	$V_{VM} + 1$	V
	Open drain output current	nFAULT	0	10	mA
	Push-pull output current	SDO	0	10	mA
T_J	Operating junction temperature		-40	150	°C
T_{stg}	Storage temperature		-65	150	°C

(1) Stresses beyond those listed under Absolute Maximum Ratings may cause permanent damage to the device. These are stress ratings only, which do not imply functional operation of the device at these or any other conditions beyond those indicated under Recommended Operating Conditions. Exposure to absolute-maximum-rated conditions for extended periods may affect device reliability.

6.2 ESD Ratings

			VALUE	UNIT
$V_{(ESD)}$	Electrostatic discharge	Human body model (HBM), per AEC Q100–002 ⁽¹⁾ HBM ESD Classification Level 2	±2000	V
		Charged device model (CDM), per AEC Q100–011 CDM ESD Classification Level C4B	±750	
		Corner pins (1, 12, 13, and 24)	±500	
		Other pins	±500	

(1) AEC Q100–002 indicates that HBM stressing shall be in accordance with the ANSI/ESDA/JEDEC JS–001 specification.

6.3 Recommended Operating Conditions

over operating free-air temperature range (unless otherwise noted)

		MIN	MAX	UNIT
V_{VM}	Power supply voltage	4.5	38	V
V_I	Logic level input voltage	0	5.5	V
f_{PWM}	Applied PWM signal (EN/IN1, PH/IN2)		100	kHz
T_A	Operating ambient temperature	–40	125	°C
T_J	Operating junction temperature	–40	150	°C

6.4 Thermal Information

THERMAL METRIC ⁽¹⁾		DRV8873-Q1	UNIT
		PWP (HTSSOP)	
		24 PINS	
$R_{\theta JA}$	Junction-to-ambient thermal resistance	27.8	°C/W
$R_{\theta JC(top)}$	Junction-to-case (top) thermal resistance	18.8	°C/W
$R_{\theta JB}$	Junction-to-board thermal resistance	5.1	°C/W
Ψ_{JT}	Junction-to-top characterization parameter	0.3	°C/W
Ψ_{JB}	Junction-to-board characterization parameter	5.2	°C/W
$R_{\theta JC(bot)}$	Junction-to-case (bottom) thermal resistance	1.0	°C/W

(1) For more information about traditional and new thermal metrics, see the [Semiconductor and IC Package Thermal Metrics](#) application report.

6.5 Electrical Characteristics

Over recommended operating conditions unless otherwise noted. Typical limits apply for $T_A = 25^\circ\text{C}$ and $V_{VM} = 13.5\text{ V}$

PARAMETER		TEST CONDITIONS	MIN	TYP	MAX	UNIT
POWER SUPPLIES (VM, DVDD)						
V_{VM}	VM operating voltage		4.5		38	V
I_{VM}	VM operating supply current	$V_{VM} = 13.5\text{ V}$; nSLEEP = 1; DISABLE = 0		5	10	mA
$I_{VM(Q)}$	VM sleep mode supply current	$V_{VM} = 13.5\text{ V}$; nSLEEP = 0		15	30	μA
V_{DVDD}	Internal logic regulator voltage	2-mA load, $V_{VM} > 5.5\text{ V}$	4.7	5	5.3	V
$t_{(SLEEP)}$	Sleep time	nSLEEP low to start device shutdown	50			μs
$t_{(RESET)}$	nSLEEP reset pulse	nSLEEP low to only clear fault registers	5		20	μs
$t_{(WAKE)}$	Wake-up time	nSLEEP high to device ready for input signals			1.5	ms
t_{on}	Turn-on time	$V_M > V_{(UVLO)}$; nSLEEP = 1, to output transition			1.5	ms
$t_{(DISABLE)}$	DISABLE deglitch time	DISABLE signal transition		2.5		μs
CHARGE PUMP (VCP, CPH, CPL)						
V_{VCP}	VCP operating voltage			5		V
I_{VCP}	VCP current	$V_{VM} = 13.5\text{ V}$		7	10	mA
$f_{(VCP)}$	Charge pump switching frequency	$V_{VM} > V_{(UVLO)}$; nSLEEP = 1		400		kHz

Electrical Characteristics (continued)

 Over recommended operating conditions unless otherwise noted. Typical limits apply for $T_A = 25^\circ\text{C}$ and $V_{VM} = 13.5\text{ V}$

PARAMETER		TEST CONDITIONS	MIN	TYP	MAX	UNIT
LOGIC-LEVEL INPUTS (EN/IN1, PH/IN2, nSLEEP, SCLK, SDI)						
V_{IL}	Input logic-low voltage		0		0.8	V
V_{IH}	Input logic-high voltage		1.6		5.3	V
V_{HYS}	Input logic hysteresis			150		mV
I_{IL}	Input logic-low current	$V_{IN} = 0\text{ V}$	-5		5	μA
I_{IH}	Input logic-high current	$V_{IN} = 5\text{ V}$		50		μA
R_{PD}	Internal pulldown resistance	to GND		100		k Ω
t_{pd}	Propagation delay (EN/IN1, PH/IN2 to OUTx = 50%)	SR = 000b; $I_O = 1\text{ A}$		1.2		μs
		SR = 001b; $I_O = 1\text{ A}$		1.6		
		SR = 010b; $I_O = 1\text{ A}$		2.6		
		SR = 011b; $I_O = 1\text{ A}$		3.4		
		SR = 100b; $I_O = 1\text{ A}$		4.1		
		SR = 101b; $I_O = 1\text{ A}$		5.2		
		SR = 110b; $I_O = 1\text{ A}$		7.8		
		SR = 111b; $I_O = 1\text{ A}$		13.3		
LOGIC-LEVEL INPUT (DISABLE)						
$R_{PU,DIS}$	Internal pull-up resistance	DISABLE to DVDD		100		k Ω
$V_{IL,DIS}$	Input logic-low voltage		0		0.8	V
$V_{IH,DIS}$	Input logic-high voltage		1.6		5.3	V
LOGIC-LEVEL INPUT (nSCS)						
$V_{IL,nSCS}$	Input logic-low voltage		0		0.8	V
$V_{IH,nSCS}$	Input logic-high voltage		1.6		5.3	V
$R_{PU,nSCS}$	Internal pull-up resistance	nSCS to nSLEEP		450		k Ω
LOGIC-LEVEL INPUT (nSLEEP)						
$V_{IL,SLEEP}$	Input logic-low voltage		0		0.8	V
$V_{IH,SLEEP}$	Input logic-high voltage		2.7		5.3	V
$I_{IH,SLEEP}$	Input logic-high current	$V_{IN} = 5\text{ V}$; nSCS is High			$80 + I_{SDO}^{(1)}$	μA
THREE-LEVEL INPUT (MODE)						
R_{IN-1}	Input mode 1	Tied to GND			105	Ω
R_{IN-2}	Input mode 2	Tied to GND	190			k Ω
R_{IN-3}	Input mode 3	Tied to DVDD			105	Ω
PUSH-PULL OUTPUT (SDO)						
$R_{PD,SDO}$	Internal pull-down resistance	With respect to GND		30	50	Ω
$R_{PU,SDO}$	Internal pull-up resistance	With respect to nSLEEP		120	240	Ω
OPEN DRAIN OUTPUT (nFAULT)						
V_{OL}	Output logic-low voltage	$I_O = 2\text{ mA}$			0.1	V
I_{OZ}	Output high-impedance leakage	$V_O = 5\text{ V}$	-2		2	μA
MOTOR DRIVER OUTPUTS (OUT1, OUT2)						
$R_{DS(ON)}$	High-side FET on-resistance	$V_{VM} = 13.5\text{ V}$; $T_A = 25^\circ\text{C}$; $T_J = 25^\circ\text{C}$		75		m Ω
		$V_{VM} = 13.5\text{ V}$; $T_A = 25^\circ\text{C}$; $T_J = 150^\circ\text{C}$		125	155	
$R_{DS(ON)}$	Low-side FET on-resistance	$V_{VM} = 13.5\text{ V}$; $T_A = 25^\circ\text{C}$; $T_J = 25^\circ\text{C}$		75		m Ω
		$V_{VM} = 13.5\text{ V}$; $T_A = 25^\circ\text{C}$; $T_J = 150^\circ\text{C}$		125	155	
$t_{(DEAD)}$	Output dead time	SR = 100b		500		ns
$V_{F(DIODE)}$	Body diode forward voltage	$I_O = 1\text{ A}$		0.8		V

(1) SDO output current external to the device

Electrical Characteristics (continued)

Over recommended operating conditions unless otherwise noted. Typical limits apply for $T_A = 25^\circ\text{C}$ and $V_{VM} = 13.5\text{ V}$

PARAMETER		TEST CONDITIONS	MIN	TYP	MAX	UNIT
I_{SINK}	Sink current when $\text{OUT}_x = \text{Hi-Z}$	$n\text{SLEEP} = 0$		62		μA
		$n\text{SLEEP} = 1, \text{DISABLE} = 1$		340		
SR	Slew rate (H/W Device) OUT_x 10% to 90% changing	$I_O = 1\text{ A}$; Connect to GND		53.2		$\text{V}/\mu\text{s}$
		$I_O = 1\text{ A}$; $R_{(\text{SR})} = 22\text{ k}\Omega \pm 5\%$ to GND		34		
		$I_O = 1\text{ A}$; $R_{(\text{SR})} = 68\text{ k}\Omega \pm 5\%$ to GND		18.3		
		$I_O = 1\text{ A}$; No connect (Hi-Z)		13		
		$I_O = 1\text{ A}$; $R_{(\text{SR})} = 51\text{ k}\Omega \pm 5\%$ to DVDD		7.9		
		$I_O = 1\text{ A}$; Connect to DVDD		2.6		
SR	Slew rate (SPI Device) OUT_x 10% to 90% changing	$I_O = 1\text{ A}$; SR = 000b		53.2		$\text{V}/\mu\text{s}$
		$I_O = 1\text{ A}$; SR = 001b		34		
		$I_O = 1\text{ A}$; SR = 010b		18.3		
		$I_O = 1\text{ A}$; SR = 011b		13		
		$I_O = 1\text{ A}$; SR = 100b		10.8		
		$I_O = 1\text{ A}$; SR = 101b		7.9		
		$I_O = 1\text{ A}$; SR = 110b		5.3		
		$I_O = 1\text{ A}$; SR = 111b		2.6		
CURRENT SENSE OUTPUTS (IPROPI1, IPROPI2)						
k	Current mirror scaling			1100		A/A
k_{ERR}	Current mirror scaling	$I_O < 1\text{ A}$	-50		50	mA
		$I_O \geq 1\text{ A}$	-5		5	%
$t_{(\text{IPROPI})}$	OUT_x to IPROPI	$V_O = 2\text{ V}$; SR = 000b		2.2		μs
		$V_O = 2\text{ V}$; SR = 111b		10.5		
CURRENT REGULATION						
I_{TRIP}	Current limit threshold	ITRIP_LVL = 00b; $V_{VM} = 13.5\text{ V}$	3.27	3.85	4.43	A
		ITRIP_LVL = 01b; $V_{VM} = 13.5\text{ V}$	4.6	5.4	6.2	
		ITRIP_LVL = 10b; $V_{VM} = 13.5\text{ V}$	5.5	6.5	7.5	
		ITRIP_LVL = 11b; $V_{VM} = 13.5\text{ V}$	5.95	7	8.1	
t_{OFF}	PWM off-time	TOFF = 00b		20		μs
		TOFF = 01b		40		
		TOFF = 10b		60		
		TOFF = 11b		80		
t_{BLANK}	PWM blanking time			5		μs
PROTECTION CIRCUITS						
$V_{(\text{UVLO})}$	VM undervoltage lockout	VM falling; UVLO report		4.35	4.45	V
		VM rising; UVLO recovery		4.5	4.7	
$t_{(\text{UVLO})}$	VM UVLO falling deglitch time	VM falling; UVLO report		10		μs
$V_{(\text{RST})}$	VM UVLO reset	VM falling; UVLO report; device reset			4.1	V
$V_{\text{VCP}(\text{UV})}$	Charge pump undervoltage	$V_{VM} = 12\text{ V}$; $T_A = 25^\circ\text{C}$; CPUV report		$V_{VM} + 2.25$		V
$I_{(\text{OCP})}$	Overcurrent protection trip level		10			A
$t_{(\text{OCP})}$	Overcurrent deglitch time			3	5	μs
$t_{(\text{RETRY})}$	Overcurrent retry time (H/W Device)			4		ms
$t_{(\text{RETRY})}$	Overcurrent retry time (SPI Device)	OCP_TRETRY = 00b		0.5		ms
		OCP_TRETRY = 01b		1		
		OCP_TRETRY = 10b		2		
		OCP_TRETRY = 11b		4		
V_{OLA}	Open load active mode		150	300	450	mV

Electrical Characteristics (continued)

Over recommended operating conditions unless otherwise noted. Typical limits apply for $T_A = 25^\circ\text{C}$ and $V_{VM} = 13.5\text{ V}$

PARAMETER		TEST CONDITIONS	MIN	TYP	MAX	UNIT
$t_{d(OL)}$	Open load diagnostic delay time	OL_DLY = 0b		0.3		ms
		OL_DLY = 1b		1.2		
I_{OL}	Open load current			3		mA
T_{OTW}	Thermal warning temperature	Die temperature (T_J)	140	150	160	$^\circ\text{C}$
T_{TSD}	Thermal shutdown temperature	Die Temperature (T_J)	165	175	185	$^\circ\text{C}$
T_{hys}	Thermal shutdown hysteresis	Die temperature (T_J)		20		$^\circ\text{C}$

6.6 SPI Timing Requirements

		MIN	NOM	MAX	UNIT
$t_{(READY)}$	SPI ready, $V_M > V_{(UVLO)}$		1		ms
$t_{(CLK)}$	SCLK minimum period	100			ns
$t_{(CLKH)}$	SCLK minimum high time	50			ns
$t_{(CLKL)}$	SCLK minimum low time	50			ns
$t_{su(SDI)}$	SDI input setup time	20			ns
$t_h(SDI)$	SDI input hold time	30			ns
$t_{d(SDO)}$	SDO output delay time, SCLK high to SDO valid, $C_L = 20\text{ pF}$			30	ns
$t_{su(nSCS)}$	nSCS input setup time	50			ns
$t_h(nSCS)$	nSCS input hold time	50			ns
$t_{(HI_nSCS)}$	nSCS minimum high time before active low	500			ns
$t_{dis(nSCS)}$	nSCS disable time, nSCS high to SDO high impedance		10		ns



图 1. SPI Slave-Mode Timing Definition

6.7 Typical Characteristics



图 2. R_{DS(on)} vs Temperature

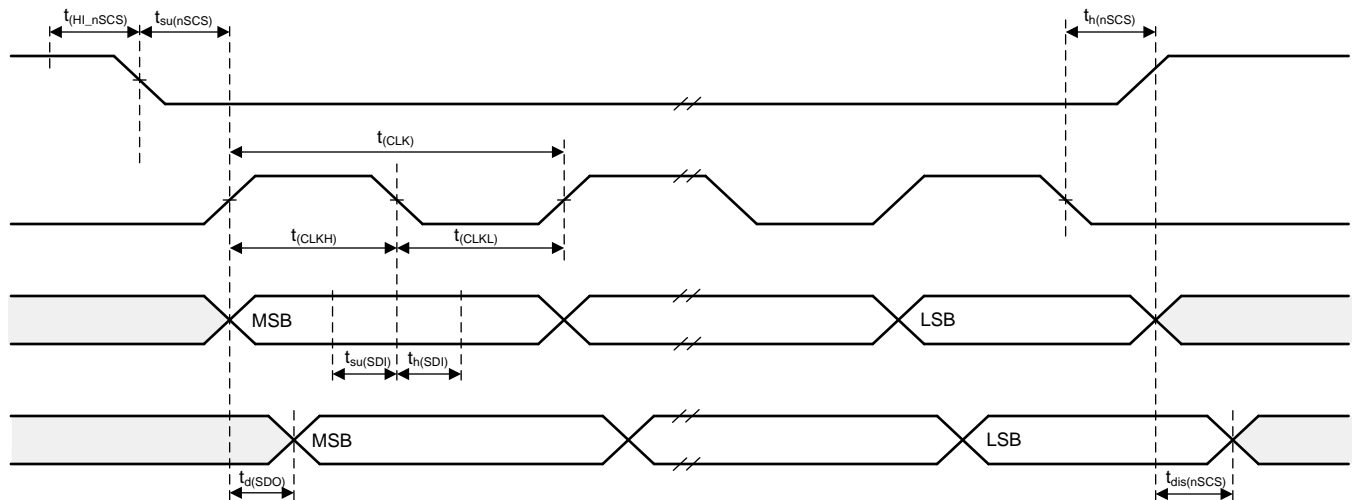

图 3. Operating Current (I_{VM}) vs Temperature

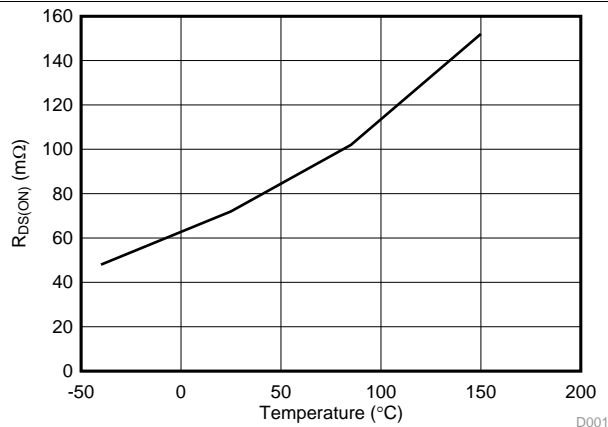

图 4. Sleep Current (I_{VM(Q)}) vs Temperature

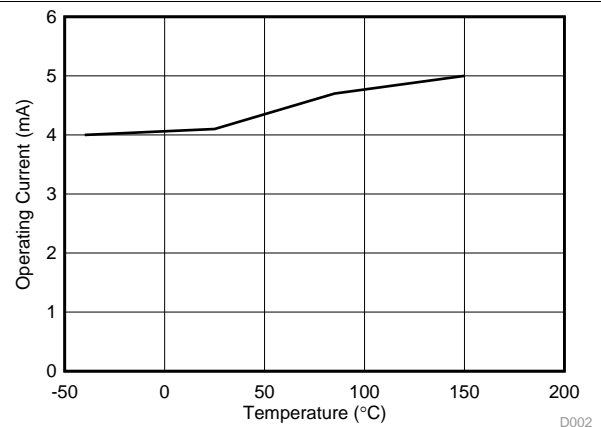

ITRIP = 01b

图 5. ITRIP Current vs Temperature

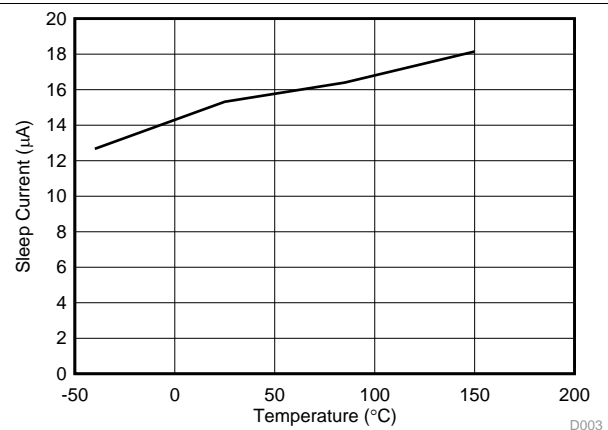
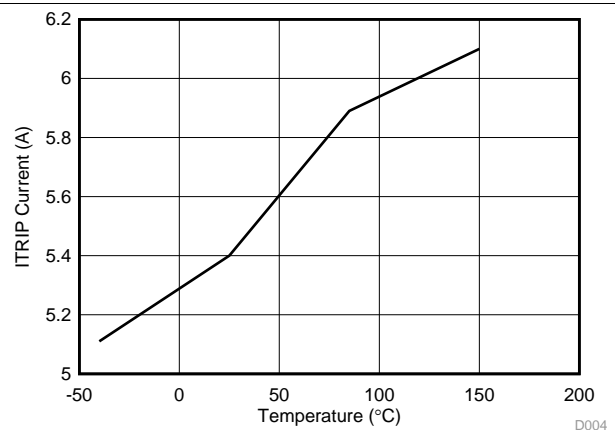
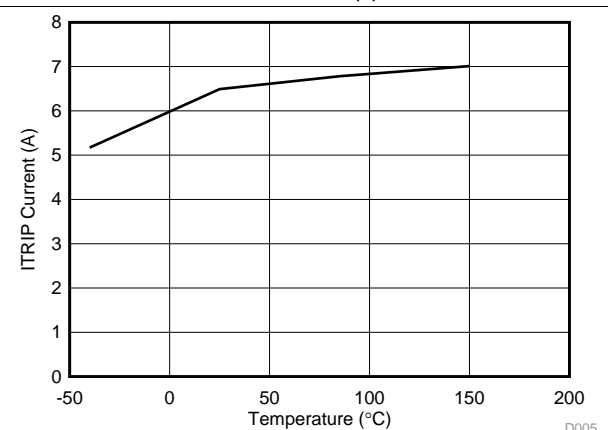

ITRIP = 10b

图 6. ITRIP Current vs Temperature

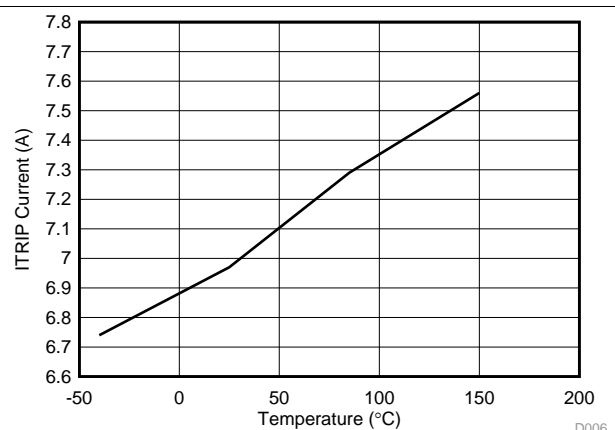

ITRIP = 11b

图 7. ITRIP Current vs Temperature

7 Detailed Description

7.1 Overview

The device is an integrated, 4.5-V to 38-V motor driver for automotive brushed-motor applications. The device is capable of high output-current drive using low- $R_{DS(ON)}$ integrated MOSFETs.

A standard 4-wire serial peripheral interface (SPI) decreases the device pin count by allowing the various device settings and fault reporting to be managed through an external controller. Alternatively a hardware interface option device is available for easy configuration with less detailed control of all device functions.

The device integrates a current mirror which provides an output current proportional to the current through the high-side FETs. This feature allows the system to monitor the motor current without the need for a large high-power resistor for current sensing. The device has a built-in current regulation feature with a fixed off-time current-chopping scheme. The current-chopping level is selected through SPI in the SPI version of the device and in the hardware version of the device is it a fixed value.

In addition to the high level of driver integration, the device provides a broad range of integrated protection features. These features include power-supply undervoltage lockout (UVLO), charge-pump undervoltage lockout, overcurrent faults, open-load detection, output short to battery and short to ground protection, and thermal shutdown. Device faults are indicated by the nFAULT pin with detailed information available in the device registers.

The device integrates a spread spectrum clocking feature for both the internal digital oscillator and internal charge pump. This feature combined with output slew rate control minimizes the radiated emissions from the device.

The device is available in a 24-pin HTSSOP package with a thermal pad.

7.2 Functional Block Diagram

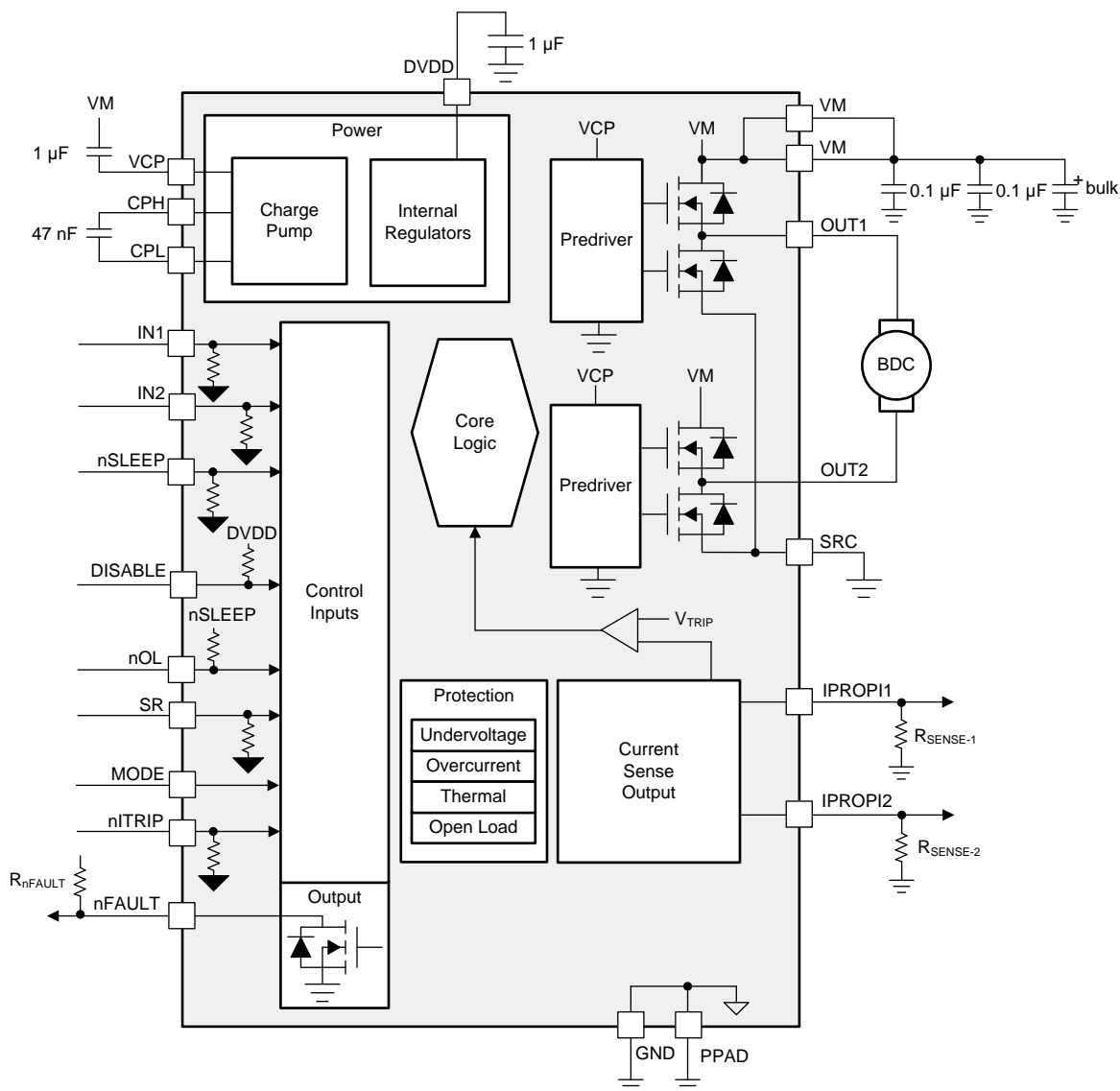

Copyright © 2017, Texas Instruments Incorporated

图 8. Hardware Device Block Diagram

Functional Block Diagram (接下页)

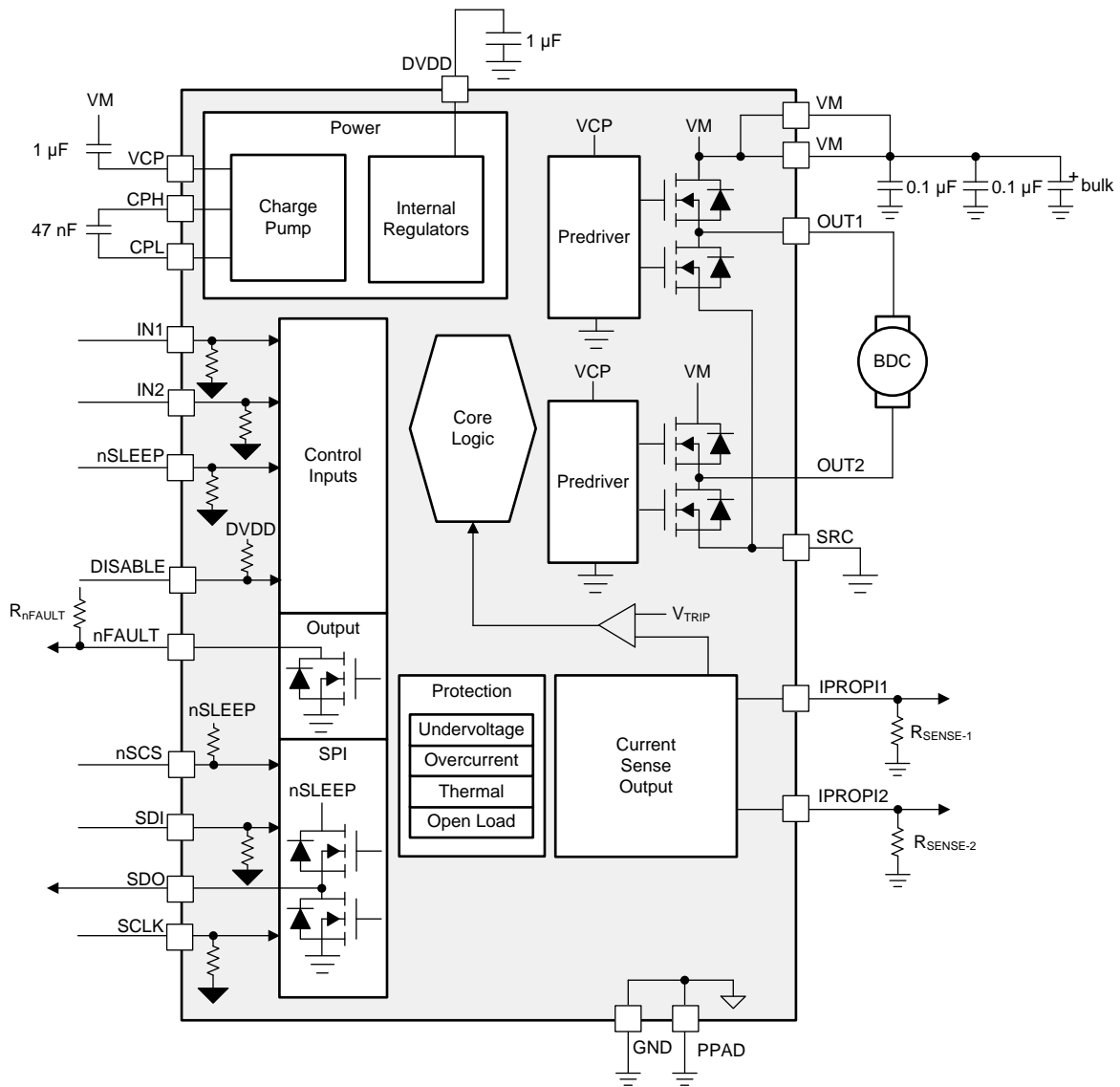

Copyright © 2017, Texas Instruments Incorporated

图 9. Software Device Block Diagram

7.3 Feature Description

表 1 lists the recommended external components for the device.

表 1. External Components

COMPONENT	PIN 1	PIN 2	RECOMMENDED
C _{VM1}	VM	GND	0.1-μF ceramic capacitor rated for VM
C _{VM2}	VM	GND	Bulk capacitor rated for VM
C _{VCP}	VCP	VM	16-V, 1-μF ceramic capacitor
C _{FLY}	CPH	CPL	47-nF capacitor rated for VM
C _{DVDD}	DVDD	GND	6.3-V, 1-μF ceramic capacitor
R _{nFAULT}	VCC ⁽¹⁾	nFAULT	≥ 10-kΩ pullup resistor
R _{MODE}	MODE	GND or DVDD	Device hardware interface
R _{SENSE-1}	IPROPI1	GND	Resistors to convert mirrored current into a voltage
R _{SENSE-2}	IPROPI2	GND	Resistors to convert mirrored current into a voltage

(1) VCC is not a pin on the device, but a VCC supply-voltage pullup is required for the open-drain output nFAULT.

7.3.1 Bridge Control

The device output has four N-channel MOSFETs configured in a H-bridge. The driver can be controlled using a PH/EN, PWM, or independent half-bridge input mode. 表 2 lists the control mode configurations.

表 2. Control Mode Configuration

HARDWARE DEVICE MODE PIN	SPI DEVICE MODE REGISTER	CONTROL MODE
L	00b	PH/EN
H	01b (default)	PWM
200 kΩ ± 5% to GND	10b	Independent half bridge
Not applicable	11b	Input disabled, bridge Hi-Z

In the hardware version of the device, the MODE pin determines the control interface and latches on power-up or when exiting sleep mode. During the device power-up sequence, the DVDD pin is enabled first, and then the MODE pin latches. Tying the MODE pin directly to ground sets the mode to phase and enable. Tying the MODE pin to the DVDD pin, or an external 5 V rail, sets the mode to PWM. Connecting the MODE pin to ground with a 200 kΩ ± 5% resistor sets the mode to independent half-bridge where the two half-bridges can be independently controlled by their respective input (INx) pins. 表 3 lists the different MODE pin settings.

表 3. DRV8873H-Q1 MODE Pin Settings

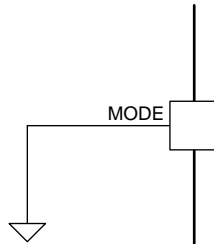
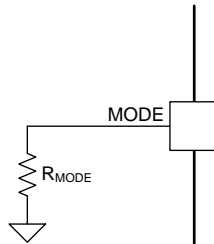
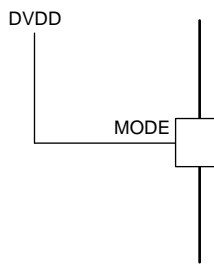
CONNECTION	MODE	CIRCUIT
Connect to GND	Phase and Enable	
200 kΩ ± 5% to GND	Independent half-bridge	
Connect to DVDD	PWM	

In the SPI version of the device, the mode setting can be changed by writing to the MODE register in the IC1 control register because this device version has no dedicated MODE pin. The device mode gets latched when the DISABLE signal transitions from high to low.

7.3.1.1 Control Modes

The device output consists of four N-channel MOSFETs that are designed to drive high current. The MOSFETs are controlled by two logic inputs, EN/IN1 and PH/IN2, in three different input modes to support various commutation and control methods, as shown in the logic tables (表 4, 表 5, and 表 6). In the Independent PWM mode, the fault handling is performed independently for each half bridge. For example, if an overcurrent condition (OCP) is detected in half-bridge 1, only the half-bridge 1 output (OUT1) is disabled and half-bridge 2 continues to operate based on the IN2 input.

表 4. PH/EN Mode Truth Table

nSLEEP	DISABLE	EN/IN1	PH/IN2	OUT1	OUT2
0	X	X	X	Hi-Z	Hi-Z
1	1	X	X	Hi-Z	Hi-Z
1	0	0	X	H	H
1	0	1	0	L	H
1	0	1	1	H	L

表 5. PWM Mode Truth Table

nSLEEP	DISABLE	EN/IN1	PH/IN2	OUT1	OUT2
0	X	X	X	Hi-Z	Hi-Z
1	1	X	X	Hi-Z	Hi-Z
1	0	0	0	Hi-Z	Hi-Z
1	0	0	1	L	H
1	0	1	0	H	L
1	0	1	1	H	H

表 6. Independent Mode Truth Table

nSLEEP	DISABLE	EN/IN1	PH/IN2	OUT1	OUT2
0	X	X	X	Hi-Z	Hi-Z
1	1	X	X	Hi-Z	Hi-Z
1	0	0	0	L	L
1	0	0	1	L	H
1	0	1	0	H	L
1	0	1	1	H	H

The inputs can be set to static voltages for 100% duty cycle drive, or they can be pulse-width modulated (PWM) for variable motor speed. When using PWM mode (MODE = 1), switching between driving and braking typically is best. For example, to drive a motor forward with 50% of its maximum revolutions per minute (RPM), the IN1 pin is high and the IN2 pin is low during the driving period. During the other period in this example, the IN1 pin is high and the IN2 pin is high.



图 10. Half-Bridge Current Paths

In the Independent PWM mode, to independently put the outputs of the half bridge in the high-impedance (Hi-Z) state, the OUT1_DIS or OUT2_DIS bit in the IC3 register must be set to 1b. Writing a logic 1 to the OUT1_DIS bit disables the OUT1 output. Writing a logic 1 to the OUT2_DIS bit disables the OUT2 output. The default value in these registers is 0b. The option to independently set the outputs of the half bridge in the Hi-Z state is not available for the hardware version of the device.

7.3.1.2 Half-Bridge Operation

The device can be used to drive two solenoids or unidirectional brushed DC-motor loads instead of a brushed-DC motor in full H-bridge configuration. Independent half-bridge control is preferred for operation in this mode; however, using the PH/EN or PWM modes is not restricted if the correct driving and braking states can be achieved.

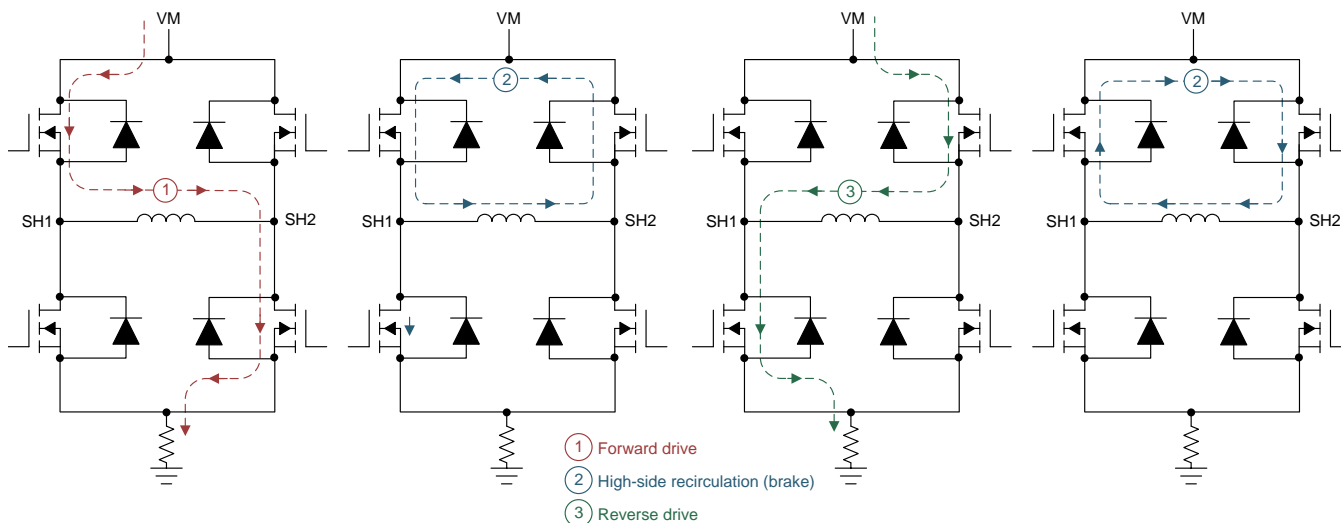
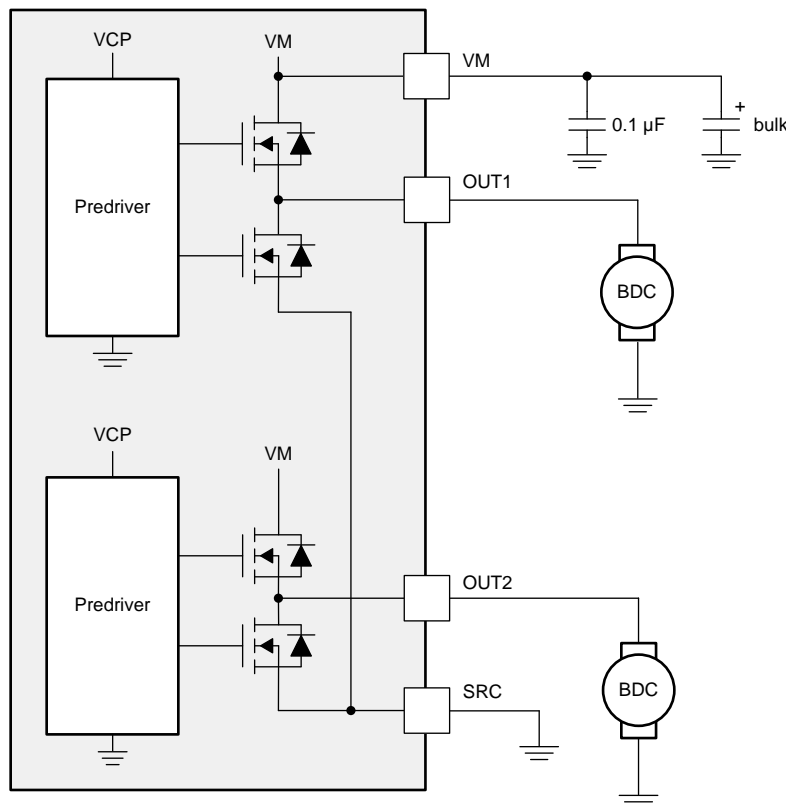

Copyright © 2017, Texas Instruments Incorporated

图 11. Independent Half bridge Mode Driving Two Low-Side Loads

TI does not recommend tying the OUT1 and OUT2 pins together and drive a load. The half bridges may be out of synchronization in this configuration and any mismatch in the input commands can momentarily result in shoot through condition. This mismatch can be mitigated by adding an inductor in-line with the outputs.

If loads are connected between the OUTx and VM pins, the device can draw more current than specified in the [Electrical Characteristics](#) table. To avoid this condition, TI recommends connecting loads in the configuration shown in [图 11](#).

Depending on how the loads are connected on the outputs pin, some of the features offered by the device could have reduced functionality. For example, having a load between the OUTx and GND pins, as shown in [图 11](#), results in false trips of the open-load diagnosis in active-mode (OLA). Having a load tied between the OUTx and VM pins restricts the use of internal current regulation because no means of measuring current flowing through the load with the current mirror block is available. [表 7](#) lists these use cases.

表 7. Control Mode Configuration

LOAD CONNECTIONS		FUNCTIONALITY	
NODE 1	NODE 2	OLA	CURRENT REGULATION (I _{TRIP})
OUTx	GND	Not Available	Operational
OUTx	VM	Operational	Not Available

7.3.1.3 Internal Current Sense and Current Regulation

The IPROPI pin outputs an analog current that is proportional to the current flowing in the H-bridge. The output current is typically 1/1100 of the current in both high-side FETs. The IPROPI pin is derived from the current through either of the high-side FETs. Because of this, the IPROPI pin does not represent the half bridge current when operating in a fast decay mode or low-side slow decay mode. The IPROPI pin represents the H-bridge current under forward drive, reverse drive, and high-side slow decay. The IPROPI output is delayed by approximately 2 μs for the fastest slew-rate setting (43.2 V/μs) after the high-side FET is switched on.



图 12. Current-Sense Block Diagram

The selection of the external resistor should be such that the voltage on the IPROPI pin is less than 5 V. Therefore the resistor must be sized less than this value based on 公式 1. The range of current that can be monitored is from 100 mA to 10 A assuming the selected external resistor meets the calculated value from 公式 1. If the current exceeds 10 A, the device could reach overcurrent protection (OCP) or overtemperature shutdown (TSD). If OCP occurs, the device disables the internal MOSFETs and protects itself (for the hardware version of the device) or based on the OCP_MODE setting (for the SPI version of the device). For guidelines on selecting a sense resistor, see the [Sense Resistor](#) section.

$$R_{(SENSE)} = k \times 5 \text{ V} / I_o$$

where

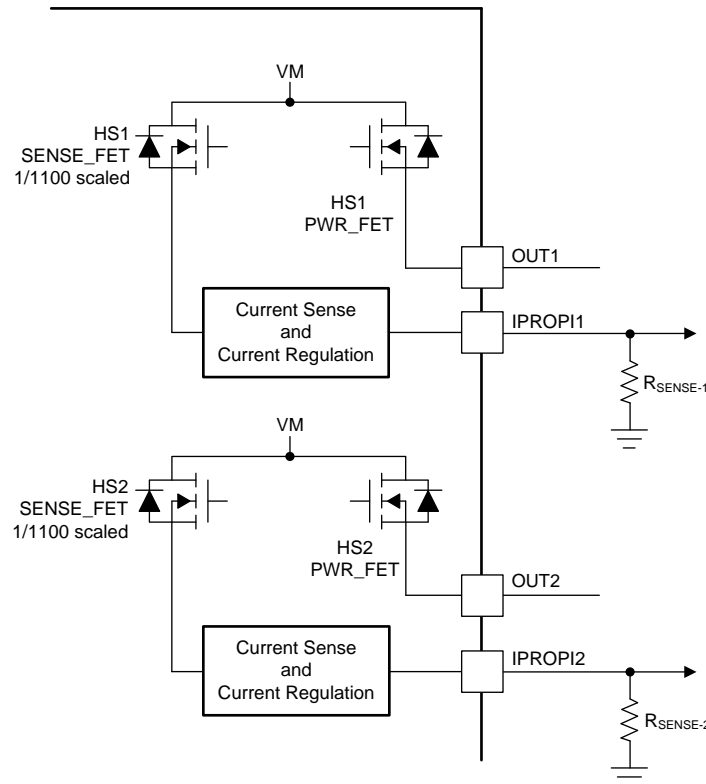
- k is the current mirror scaling factor, which is typically 1100.
- I_o is the maximum drive current to be monitored.

(1)

注

Texas Instruments recommends the load current not exceed 8 A during normal operation. If slew rate setting of 2.6 V/μs (SR = 111b) is used when the load current is about 8 A, choose TOFF to be either 40 μs or 60 μs.

The SPI version of the device limits the output current based on the trip level set in the SPI registers. In the hardware version of the device, the current trip limit is set to 6.5 A. The current regulation feature is enabled by default on both the outputs (OUT1 and OUT2). To disable current regulation in the hardware version of the device, the nITRIP pin must be connected to DVDD. To disable current regulation in the SPI version of the device, the DIS_ITRIP bits in the IC4 Control register must be written to. The bit settings are:

- 01b to disable current regulation only on the OUT1 pin
- 10b to disable current regulation only on the OUT2 pin
- 11b to disable current regulation on both the OUT1 and OUT2 pins

表 8. Control Regulation Threshold

PARAMETER	ITRIP_LVL BIT	MIN	TYP	MAX	UNIT
I_{TRIP} Current limit threshold	ITRIP_LVL = 00b	3.4	4	4.6	A
	ITRIP_LVL = 01b	4.6	5.4	6.2	A
	ITRIP_LVL = 10b	5.5	6.5	7.5	A
	ITRIP_LVL = 11b	6	7	8	A

When the I_{TRIP} current has been reached, the device enforces slow current decay by enabling both the high-side FETs for a time of t_{OFF} . In the hardware version of the device, the t_{OFF} time is 40 μ s. The t_{OFF} time is selectable through SPI in the SPI version of the device, as shown in 表 9. The default setting is 01b ($t_{OFF} = 40 \mu$ s).

表 9. PWM Off Time Settings

PARAMETER	TOFF BIT	t_{OFF} DURATION	UNIT
t_{OFF} PWM off time	TOFF = 00b	20	μ s
	TOFF = 01b	40	μ s
	TOFF = 10b	60	μ s
	TOFF = 11b	80	μ s

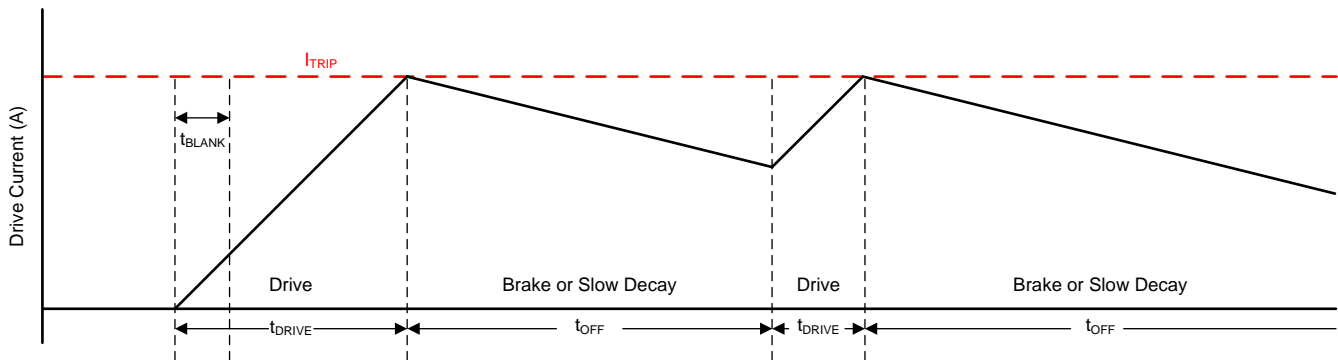
图 13. Current Regulation Time Periods

When the t_{OFF} time has elapsed and the current level falls below the current regulation (I_{TRIP}) level, the output is re-enabled according to the inputs. If, after the t_{OFF} time has elapsed the current is still higher than the I_{TRIP} level, the device enforces another t_{OFF} time period of the same duration.

The drive time (t_{DRIVE}) occurs until another ITRIP event is reached and depends heavily on the VM voltage, the back-EMF of the motor, and the inductance of the motor. During the t_{DRIVE} time, the current-sense regulator does not enforce the ITRIP limit until the t_{BLANK} time has elapsed. While in current regulation, the inputs can be toggled to drive the load in the opposite direction to decay the current faster. For example, if the load was in forward drive prior to entering current regulation it can only go into reverse drive when the driver enforces current regulation.

The IPROPI1 pin represents the current flowing through the HS1 MOSFET of half-bridge 1. The IPROPI2 pin represents the current flowing through the HS2 MOSFET of half-bridge 2. To measure current with one sense resistor, the IPROPI1 and IPROPI2 pins must be connected together with the R_{SENSE} resistor as shown in 图 14. In this configuration, the current-sense output is proportional to the sum of the currents flowing through the both high-side FETs.



图 14. Current Sense Output

7.3.1.4 Slew-Rate Control

The rise and fall times (t_r and t_f) of the outputs can be adjusted on the hardware version of the device by changing the value of an external resistor connected from the SR pin to ground. On the SPI version of the device, the slew rate can be adjusted through the SPI. The output slew rate is adjusted internally to the device by controlling the ramp rate of the driven FET gate. The voltage or resistance on the SR pin sets the output rise and fall times in the hardware version of the device.

表 10. DRV8873H-Q1 Slew Rate (SR) Pin Connections

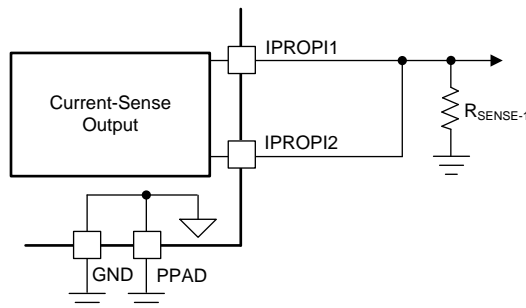
CONNECTION	SR	CIRCUIT
Connect to GND	53.2 V/ μ s	
22 k Ω \pm 5% to GND	34 V/ μ s	
68 k Ω \pm 5% to GND	18.3 V/ μ s	

表 10. DRV8873H-Q1 Slew Rate (SR) Pin Connections (接下页)

CONNECTION	SR	CIRCUIT
> 2 M Ω to GND (Hi-Z)	13 V/ μ s	
51 k Ω \pm 5% to DVDD	7.9 V/ μ s	
Connect to DVDD	2.6 V/ μ s	

图 15 shows the internal circuit block for the SR pin.



图 15. SR Block Diagram

表 11 lists the settings in the SPI register that set the output rise and fall times in the SPI version of the device.

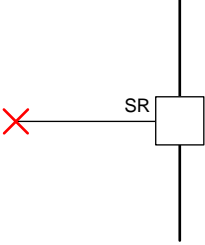
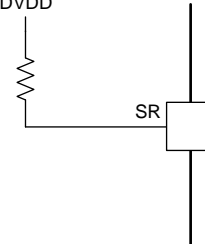
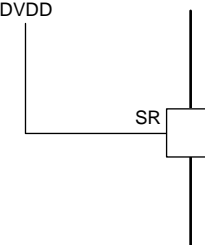
表 11. DRV8873S-Q1 Slew Rate Settings

SR	RISE TIME (V/μs)	FALL TIME (V/μs)
000b	53.2	53.2
001b	34	34
010b	18.3	18.3
011b	13	13
100b	10.8	10.8
101b	7.9	7.9
110b	5.3	5.3
111b	2.6	2.6

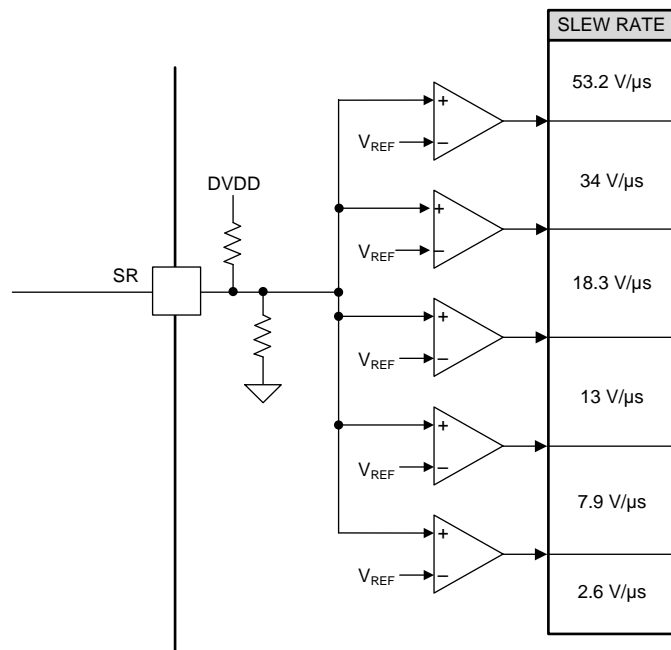
The typical voltage on the SR pin is 3 V and is driven internally. Changing the resistor value on the SR pin changes the slew-rate setting from approximately 2.6 V/μs to 53.2 V/μs. The recommended values for the external resistor are shown in the [Slew Rate](#) section. If the SR pin is grounded then the slew rate is 53.2 V/μs. Leaving the SR pin as a no-connect pin sets the slew rate to 13 V/μs. Tying it to the DVDD pin sets the slew rate to 2.6 V/μs.

7.3.1.5 Dead Time

The dead time (t_{DEAD}) is measured as the time when the OUTx pin is in the Hi-Z state between turning off one of the half bridge MOSFETs and turning on the other. For example, the output is in the Hi-Z state between turning off the high-side MOSFET and turning on the low-side MOSFET, or turning on the high-side MOSFET and turning off the low-side MOSFET.



图 16. Propagation Delay Time

If the output pin is measured during the t_{DEAD} time the voltage depends on the direction of the current. If the current is leaving the pin, the voltage is a diode drop below ground. If the current is entering the pin, the voltage is a diode drop above VM. The diode drop is associated with the body diode of the high-side or the low-side FET. The dead time is dependent on the slew-rate setting because a portion of the FET gate ramp includes the observable dead time.

7.3.1.6 Propagation Delay

The propagation delay time (t_{PD}) is measured as the time between an input edge to an output change. This time comprises two parts: an input deglitcher and output slewing delay. The input deglitcher prevents noise on the input pins from affecting the output state. The adjustable slew rate also contributes to the propagation delay time. For the fastest slew-rate setting, the t_{PD} time is typically 1.5 μs , and for the slowest slew-rate setting, the t_{PD} time is typically 4.5 μs . For the output to change state during normal operation, one FET must first be turned off.

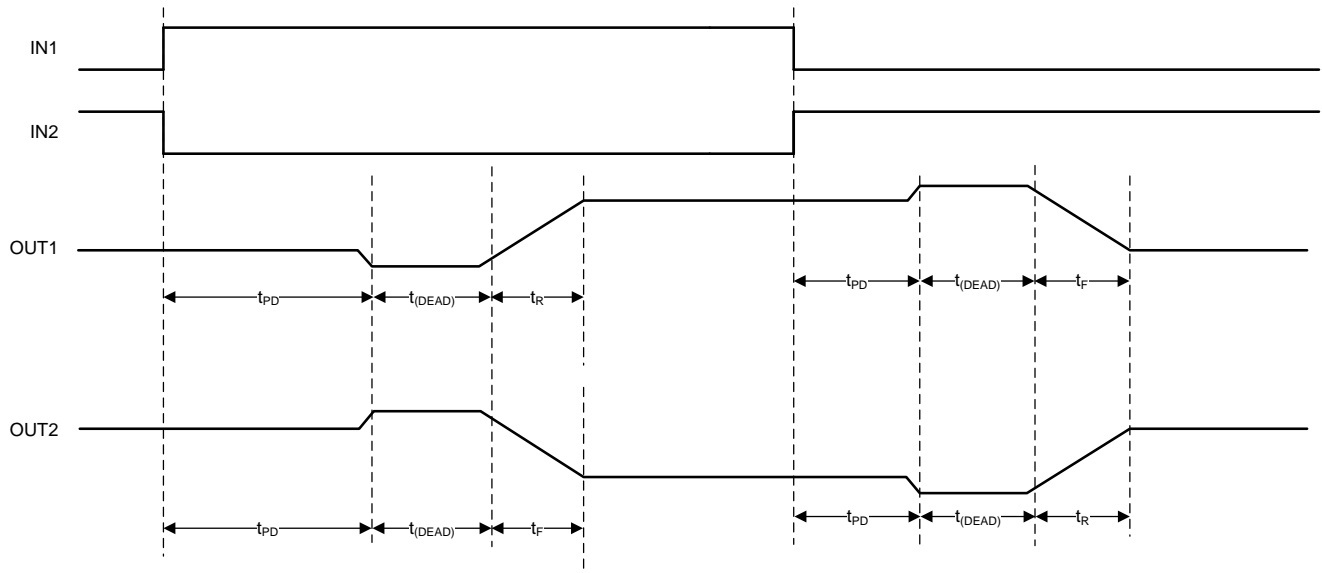
7.3.1.7 nFAULT Pin

The nFAULT pin has an open-drain output and should be pulled up to a 5-V or 3.3-V supply. When a fault is detected, the nFAULT line is logic low. For a 3.3-V pullup the nFAULT pin can be tied to the DVDD pin with a resistor (see the [Application and Implementation](#) section). For a 5-V pullup, an external 5-V supply must be used.



图 17. nFAULT Pin

During the device power-up sequence, or when exiting sleep mode, the nFAULT pin is held low until the digital core is alive and functional. This low level signal on the nFAULT line does not represent a fault condition. The signal can be used by the external MCU to determine when the digital core of the device is ready; however, this does not mean that the device is ready to accept input commands via the INx pins.

7.3.1.8 nSLEEP as SDO Reference

The nSLEEP pin manages the state of the device. The device goes into sleep mode with a logic-low signal, and comes out of sleep mode when the nSLEEP pin goes high. The signal level when the nSLEEP pin goes high determines the logic level on the SDO output in the SPI version of the device. A 3.3-V signal on the nSLEEP pin provides a 3.3-V output on the SDO output. A 5-V signal on the nSLEEP pin provides a 5-V output on the SDO pin. If the sleep feature is not required, the nSLEEP pin can be connected to the MCU power supply. In that case, when the MCU is powered-up, the motor driver device is also powered-up.

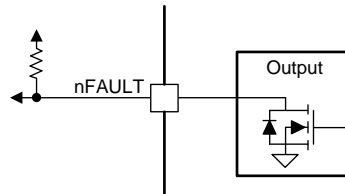

图 18. nSCS and nSLEEP Circuit

In the SPI version of the device, if the nSLEEP reset pulse is used to clear faults, the SDO voltage reference is not available for the duration of the nSLEEP reset pulse. No data can be transmitted on the SDO line for the duration when the nSLEEP pin is held low. Therefore, TI recommends using the CLR_FLT bit in the IC3 control register to clear the faults.

7.3.2 Motor Driver Protection Circuits

The device is fully protected against VM undervoltage conditions, charge-pump undervoltage conditions, overcurrent events, and overtemperature events.

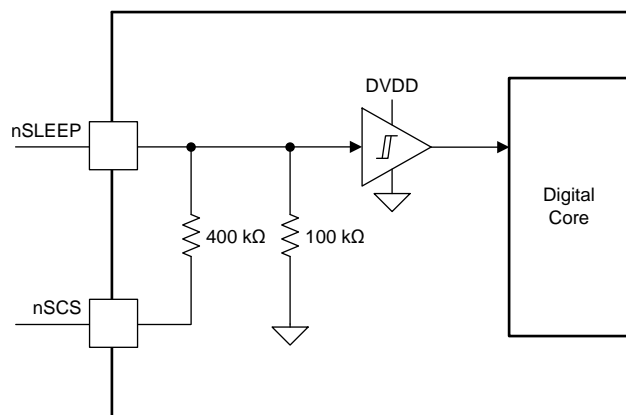
7.3.2.1 VM Undervoltage Lockout (UVLO)

If at any time the voltage on the VM pin falls below the UVLO-threshold voltage, $V_{(UVLO)}$, for the voltage supply, all the outputs (OUTx) are disabled, and the nFAULT pin is driven low. The charge pump is disabled in this condition. The FAULT and UVLO bits are latched high in the SPI registers. Normal operation resumes (motor-driver operation and nFAULT released) when the VM undervoltage condition is removed. The UVLO bit remains set until it is cleared through the CLR_FLT bit or an nSLEEP reset pulse.

注

During the power-up sequence VM must exceed $V_{(UVLO)}$ recovery max limit in order to power-up and function properly. After a successful power-up sequence, the device can operate down to the $V_{(UVLO)}$ report limit before going into the undervoltage lockout condition.

7.3.2.2 VCP Undervoltage Lockout (CPUV)

If at any time the voltage on the VCP pin falls below the $V_{VCP(UV)}$ voltage for the charge pump, all the outputs (OUTx) are disabled, and the nFAULT pin is driven low. The charge pump remains active during this condition. The FAULT and CPUV bits are latched high in the SPI registers. Normal operation resumes (motor-driver operation and nFAULT released) when the VCP undervoltage condition is removed. The CPUV bit remains set until it is cleared through the CLR_FLT bit or an nSLEEP reset pulse. This protection feature can be disabled by setting the DIS_CPUV bit high.

7.3.2.3 Overcurrent Protection (OCP)

If the current in any FET exceeds the $I_{(ocp)}$ limits for longer than the $t_{(OCP)}$ time, all FETs in the half bridge are disabled and the nFAULT pin is driven low. The charge pump remains active during this condition. The overcurrent protection can operate in four different modes: latched shutdown, automatic retry, report only, and disabled. In the independent PWM mode (MODE = 10b or MODE pin to ground with a $200\text{-k}\Omega \pm 5\%$ resistor) the fault handling is performed independently for each half-bridge based on the OCP mode selected. This protection scheme protects the outputs from shorts to battery and shorts to ground.

7.3.2.3.1 Latched Shutdown (OCP_MODE = 00b)

In this mode, after an OCP event, all the outputs (OUTx) are disabled and the nFAULT pin are driven low. The FAULT, OCP, and corresponding MOSFET OCP bits are latched high in the SPI registers. Normal operation resumes (motor-driver operation and nFAULT released) when the OCP condition is removed and a clear faults command has been issued either through the CLR_FLT bit or an nSLEEP reset pulse. This mode is the default mode for an OCP event for both the hardware version and SPI version of the device.

7.3.2.3.2 Automatic Retry (OCP_MODE = 01b)

In this mode, after an OCP event all the outputs (OUTx) are disabled and the nFAULT pin is driven low. The FAULT, OCP, and corresponding MOSFET OCP bits are latched high in the SPI registers. Normal operation resumes automatically (motor-driver operation and nFAULT released) after the $t_{(RETRY)}$ time has elapsed and the fault condition is removed.

7.3.2.3.3 Report Only (OCP_MODE = 10b)

In this mode, no protective action is performed when an overcurrent event occurs. The overcurrent event is reported by driving the nFAULT pin low and latching the FAULT, OCP, and corresponding MOSFET OCP bits high in the SPI registers. The motor driver continues to operate. The external controller acts appropriately to manage the overcurrent condition. The reporting is cleared (nFAULT released) when the OCP condition is removed and a clear faults command has been issued either through the CLR_FLT bit or an nSLEEP reset pulse.

7.3.2.3.4 Disabled (OCP_MODE = 11b)

In this mode, no protective or reporting action is performed when an overcurrent event occurs. The device continues to drive the load based on the input signals.

7.3.2.4 Open-Load Detection (OLD)

If the motor is disconnected from the device, an open-load condition is detected and the nFAULT pin is latched low until a clear faults command is issued by the MCU either through the CLR_FLT bit or an nSLEEP reset pulse. The fault also clears when the device is power cycled or comes out of sleep mode. The OLD test is designed for applications that have capacitance less than 15 nF when the OL_DLY bit set to 0b and for less than 60 nF when the OL_DLY bit is set to 1b on the OUTx pins. This setting is equivalent to measuring the resistance values listed in [表 12](#).

表 12. Resistance for Open Load Detection

NODE 1	NODE 2	RESISTANCE	COMMENTS
OUT1	OUT2	2 kΩ	
OUTx	VM	12 kΩ	V _{VM} = 13.5 V
OUTx	GND	3 kΩ	

Open load detection works in both standby mode (OLP) and active mode (OLA). OLP detects the presence of the motor prior to commutating the motor. OLA detects the motor disconnection from the driver during commutation.

7.3.2.4.1 Open-Load Detection in Passive Mode (OLP)

The open-load passive diagnostic (OLP) is different for the hardware and SPI version of the device. The OLP test is available in all three modes of operation (PN/EN, PWM, and independent half-bridge). When the open-load test is running, the internal power MOSFETs are disabled.

For the hardware version of the device, the OLP test is performed at power-up or after exiting sleep mode if the nOL pin is left as a no connect pin (or tied to GND). If the nOL pin is tied to the DVDD pin (or an external 5-V rail), the OLP test is not performed by the device.

For the SPI version of the device, the OLP test is performed when commanded. The following sequence shows how to perform the OLP test directly after the device powers up:

1. Power up the device (DISABLE pin high).
2. Select the mode through SPI.
3. Wait for the t_{DISABLE} time to expire.
4. Write 1b to the EN_OL bit in the IC1 register.
5. Perform the OLP test.
 - If an open load (OL) is detected, the nFAULT pin is driven low, the FAULT and OLx bits are latched high. When the OL condition is removed, a clear faults command must be issued by the MCU either through the CLR_FLT bit or an nSLEEP reset pulse which resets the OLx register bit.
 - If an OL condition is not detected, the EN_OL bits return to the default setting (0b) after the $t_{\text{d(OL)}}$ time expires.
6. Set the DISABLE pin low so that the device drives the motor or load based on the input signals.

If an open-load diagnostic is performed at any other time, the following sequence must be followed:

1. Set the pin DISABLE high (to disable the half bridge outputs).
2. Wait for the t_{DISABLE} time to expire.
3. Write 1b to the EN_OL bit in the IC1 register.
4. Perform the OLP test.
 - If an OL condition is detected, the nFAULT pin is driven low, and the FAULT and OLx bits are latched high. When the OL condition is removed, a clear faults command must be issued by the MCU either through the CLR_FLT bit or an nSLEEP reset pulse which resets the OLx register bits.
 - If an OL condition is not detected, the EN_OL bits return to the default setting (0b) after the $t_{\text{d(OL)}}$ time expires.

- Set the DISABLE pin low so that the device drives the motor or load based on the input signals.



图 19. Open-Load Detection Circuit

The EN_OL register maintains the written command until the diagnostic is complete. The signal on the DISABLE pin must remain high for the entire duration of the test. While the OLP test is running, if the DISABLE pin goes low, the OLP test is aborted to resume normal operation and no fault is reported. The OLP test is not performed if the motor is energized.

The OLD test checks for a high-impedance connection on the OUTx pins. The diagnostic runs in two steps. First the pullup current source is enabled. If a load is connected, the current passes through the pullup resistor and the OLx_PU comparator output remains low. If an OL condition exists, the current through the pullup resistor goes to 0 A and the OLx_PU comparator trips high. Second the pulldown current source is enabled. In the same way, the OLx_PD comparator output either remains low to indicate that a load is connected, or trips high to indicate an OL condition.

If both the OLx_PU and OLx_PD comparators report an OL condition, the OLx bit in the SPI register latches high and the nFAULT line goes low to indicate an OL fault. When the OL condition is removed, a clear faults command must be issued by the MCU either through the CLR_FLT bit or an nSLEEP reset pulse which resets the OL1 and OL2 register bits. The charge pump remains active during this fault condition.

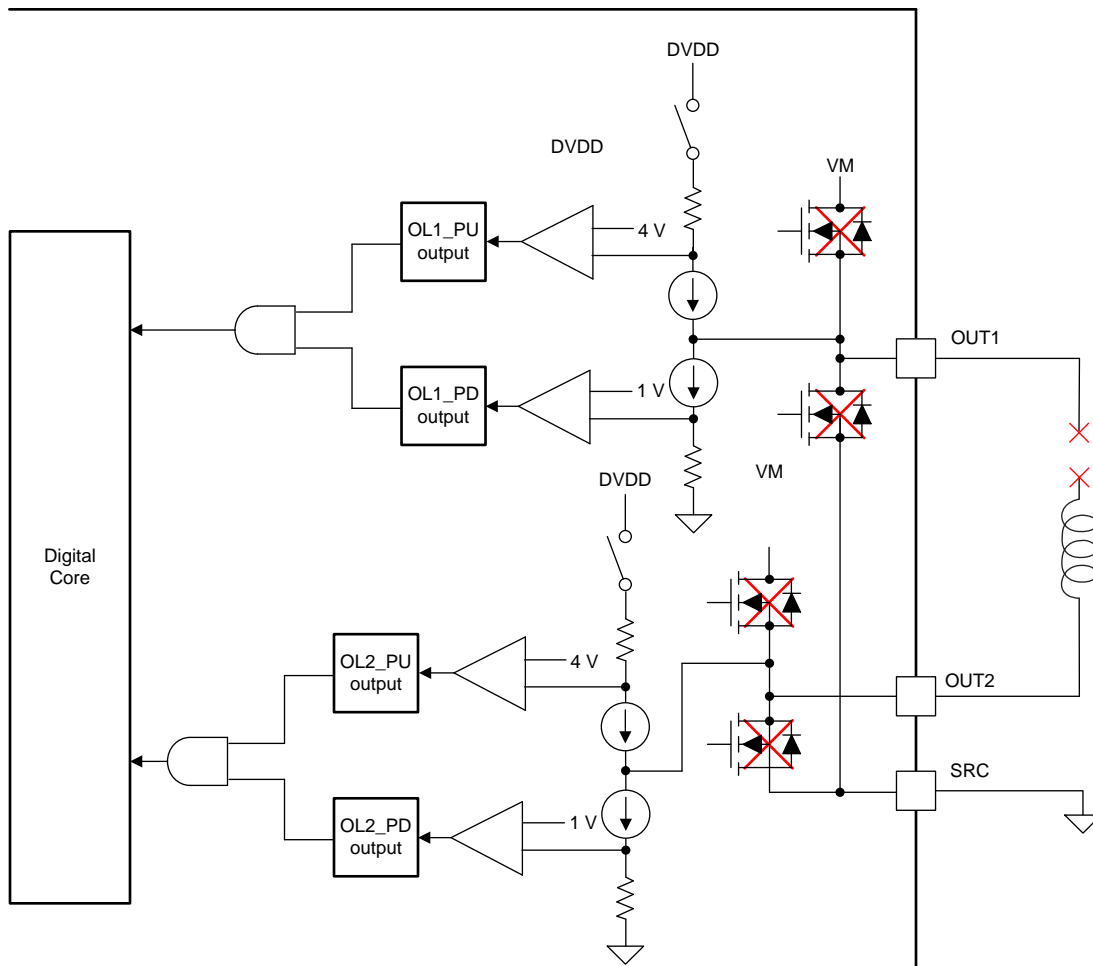
7.3.2.4.2 Open-Load Detection in Active Mode (OLA)

Open load in active mode is detected when the OUT1 and OUT2 voltages do not exhibit overshoot greater than the V_{OLA} over V_M between the time the low-side FET is switched off and the high-side FET is switched on during an output PWM cycle, as shown in Figure 20. An open load is not detected if the energy stored in the inductor is high enough to cause an overshoot greater than the V_{OLA} over V_M caused by the flyback current flowing through the body diode of the high-side FET. The OLA diagnostic is disabled by default and can be enabled by writing a 1b to the EN_OLA bit in IC4 control register.



图 20. Open-Load Active Mode Circuit

In PH/EN and PWM mode, the motor current decays by high-side recirculation. In independent PWM mode, the motor can enter the brake state either by high-side or low-side recirculation. If the motor enters the brake state using low-side recirculation, the diode V_F voltage of high-side FET is less than the V_{OLA} voltage which flags an open load fault even though the load is connected across the OUT1 and OUT2 pins. In this case, the OLA mode should not be used. If high-side current recirculation is done with independent PWM mode, the OLA mode functions properly.

注

The OLA mode is functional only when high-side recirculation of the motor current occurs. Depending on the operation conditions and external circuitry, such as the output capacitors, an open load condition could be indicated even though the load is present. This case might occur, for example, during a direction change or for small load currents with respectively small PWM duty cycles. Therefore, TI recommends evaluating the open load diagnosis only in known, suitable operating conditions and to ignore it otherwise.

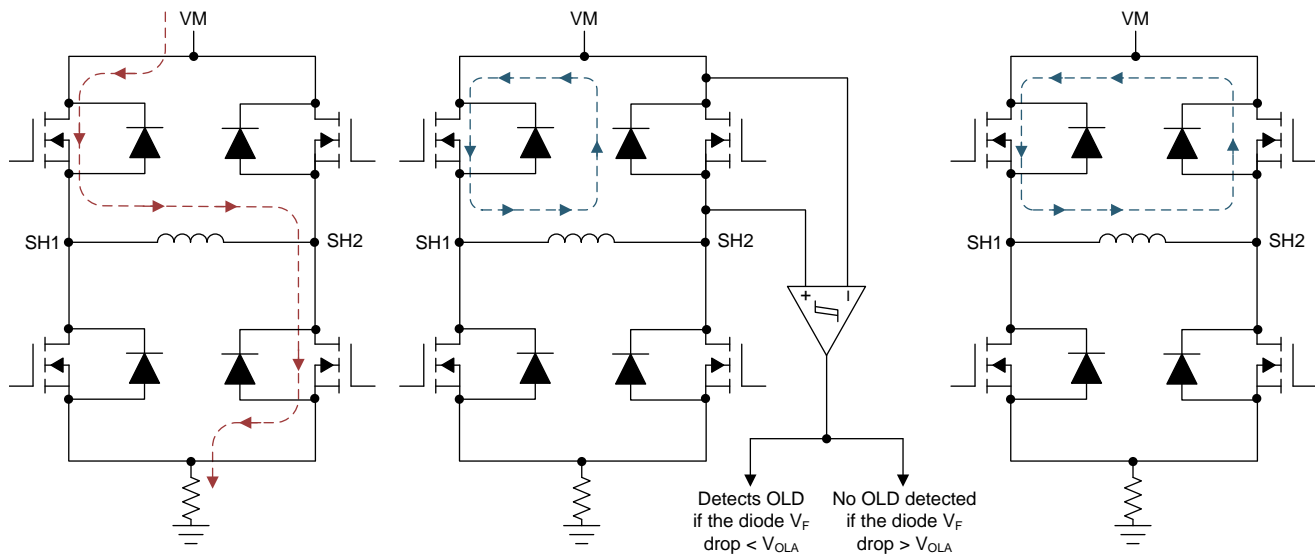
To avoid inadvertently triggering the open load diagnosis, a failure counter is implemented. Three consecutive occurrences of the internal open-load signal must occur, essentially three consecutive PWM pulses without freewheeling detected, before an open load condition is reported by the nFAULT pin and in the SPI register.

In the hardware version of the device, OLA mode is active when the nOL pin is left as a no-connect pin or tied to ground. If low-side current recirculation is done with independent PWM control, an open load condition is detected even though the load is connected. To avoid this false trip, the OLD must be disabled by taking the nOL pin high; however, both OLA and OLP diagnostics will be disabled.

7.3.2.5 Thermal Shutdown (TSD)

If the die temperature exceeds the thermal shutdown limit, the half bridge are disabled, and the nFAULT pin is driven low. The charge pump remains active during this condition. In addition, the FAULT bit and TSD bit are latched high. This protection feature cannot be disabled. The overtemperature protection can operate in two different modes: latched shutdown and automatic recovery.

7.3.2.5.1 Latched Shutdown (TSD_MODE = 0b)

In this mode, after a TSD event all the outputs (OUTx) are disabled and the nFAULT pin is driven low. The FAULT and TSD bits are latched high in the SPI register. Normal operation resumes (motor-driver operation and the nFAULT line released) when the TSD condition is removed and a clear faults command has been issued either through the CLR_FLT bit or an nSLEEP reset pulse. This mode is the default mode for a TSD event in the SPI version of the device.

7.3.2.5.2 Automatic Recovery (TSD_MODE = 1b)

In this mode, after a TSD event all the outputs (OUTx) are disabled and the nFAULT pin is driven low. The FAULT and TSD bits are latched high in the SPI register. Normal operation resumes (motor-driver operation and the nFAULT line released) when the junction temperature falls below the overtemperature threshold limit minus the hysteresis ($T_{TSD} - T_{HYS}$). The TSD bit remains latched high indicating that a thermal event occurred until a clear faults command is issued either through the CLR_FLT bit or an nSLEEP reset pulse. This mode is the default mode for a TSD event in the hardware version of the device.

7.3.2.6 Thermal Warning (OTW)

If the die temperature exceeds the trip point of the thermal warning (T_{OTW}) the OTW bit is set in the registers of SPI devices. The device performs no additional action and continues to function. When the die temperature falls below the hysteresis point of the thermal warning, the OTW bit clears automatically. The OTW bit can also be configured to report on the nFAULT pin, and set the FAULT bit in the SPI version of the device, by setting the OTW_REP bit to 1b through the SPI registers. The charge pump remains active during this condition.

表 13. Fault Response

FAULT	CONDITION	CONFIGURATION	REPORT	HALF BRIDGE	LOGIC	RECOVERY
VM undervoltage (UVLO)	$V_{VM} < V_{(UVLO)}$ (maximum 4.45 V)	—	nFAULT	Hi-Z	Reset	Automatic: $V_{VM} > V_{(UVLO)}$ (maximum 4.55 V)
Charge pump undervoltage (CPUV)	$V_{VCP} < V_{VCP(UV)}$ (typical $V_{VM} + 2.25$ V)	DIS_CPUV = 0b	nFAULT	Hi-Z	Active	Automatic: $V_{VCP} > V_{VCP(UV)}$ (typical $V_{VM} + 2.25$ V)
		DIS_CPUV = 1b	none	Active	Active	No action
Overcurrent (OCP)	$I_O > I_{(OCP)}$ (minimum 10 A)	OCP_MODE = 00b	nFAULT	Hi-Z	Active	Latched: CLR_FLT/nSLEEP
		OCP_MODE = 01b	nFAULT	Hi-Z	Active	Retry: $t_{(RETRY)}$
		OCP_MODE = 10b	nFAULT	Active	Active	No action
		OCP_MODE = 11b	none	Active	Active	No action
Open load (OLD)	No load detected	EN_OLP = 1b	nFAULT	Active	Active	Latched: CLR_FLT/nSLEEP
		EN_OLA = 1b	nFAULT	Active	Active	Latched: CLR_FLT/nSLEEP
Current regulation (ITRIPx)	$I_O > ITRIP_LVL$	ITRIP_REP = 0b	none	Active	Active	No action
		ITRIP_REP = 1b	nFAULT	Active	Active	No action
Thermal shutdown (TSD)	$T_J > T_{TSD}$ (minimum 165°C)	TSD_MODE = 0b	nFAULT	Hi-Z	Active	Latched: CLR_FLT/nSLEEP
		TSD_MODE = 1b	nFAULT	Hi-Z	Active	Automatic: $T_J > T_{TSD} - T_{HYS}$ (T_{HYS} typical 20°C)
Thermal Warning (OTW)	$T_J > T_{OTW}$ (minimum 140°C)	OTW_REP = 0b	none	Active	Active	No action
		OTW_REP = 1b	nFAULT	Active	Active	Automatic: $T_J < T_{OTW} - T_{HYS}$

7.3.3 Hardware Interface

The hardware-interface device option lets the device be configured without a SPI, however not all of the functionality is configurable. The following configuration settings are fixed for the hardware interface device option:

- CPUV is enabled
- OCP_MODE is latched shutdown
- TSD_MODE is automatic recovery
- OL_DLY is 300 μ s
- ITRIP level is 6.5-A if current regulation is enabled by the nITRIP pin
- OLA is activated when the open load diagnostic is enabled by the nOL pin
- No option to independently set the outputs (OUTx) to the Hi-Z state

7.3.3.1 MODE (Tri-Level Input)

The MODE pin of the hardware version of the device determines the control interface and latches on power-up or when exiting sleep mode. 表 14 lists the different control interfaces that can be set with the MODE pin.

表 14. DRV8873H-Q1 MODE Settings

MODE	CONTROL MODE
L	PH/EN
H	PWM
Hi-Z (200 k Ω \pm 5% to GND)	Independent half bridge

When the MODE pin is latched on power-up or when exiting sleep mode; any additional changes to the signal at the MODE pin are ignored by the device. To change the mode settings, a power cycle or sleep reset must be performed on the device. To use the device in PWM mode, tie the MODE pin to either the DVDD pin or an external 5-V rail. To use the device in independent half-bridge mode, the MODE pin must be connected to with a 200-k Ω \pm 5% resistor (or left as a no connect). Tying the MODE pin to the GND pin puts the device in phase and enable (PH/EN) mode.

7.3.3.2 Slew Rate

The rise and fall times of the outputs can be selected based on the configuration listed in 表 15 for the hardware version of the device.

表 15. Slew Rate Settings in H/W Device

SR PIN CONNECTION	RISE TIME (V/ μ s)	FALL TIME (V/ μ s)
Connect to GND	53.2	53.2
22 k Ω \pm 5% to GND	34	34
68 k Ω \pm 5% to GND	18.3	18.3
> 2M Ω to GND (Hi-Z)	13	13
51 k Ω \pm 5% to DVDD	7.9	7.9
Connect to DVDD	2.6	2.6

7.4 Device Functional Modes

7.4.1 Motor Driver Functional Modes

7.4.1.1 Sleep Mode (nSLEEP = 0)

The nSLEEP pin sets the state of the device. When the nSLEEP pin is low, the device goes to a low-power sleep mode. In sleep mode, all the internal MOSFETs are disabled, the charge pump is disabled, and the SPI is disabled. The $t_{(SLEEP)}$ time must elapse after a falling edge on the nSLEEP pin before the device enters sleep mode. The device goes from sleep mode automatically if the nSLEEP pin is brought high. The $t_{(WAKE)}$ time must elapse before the device is ready for inputs.

Device Functional Modes (接下页)

7.4.1.2 Disable Mode ($nSLEEP = 1$, $DISABLE = 1$)

The DISABLE pin is used to enable or disable the half bridge in the device. When the DISABLE pin is high, the output drivers are disabled in the Hi-Z state. In this mode, the open-load diagnostic can be performed for the SPI version of the device because the SPI remains active.

7.4.1.3 Operating Mode ($nSLEEP = 1$, $DISABLE = 0$)

When the $nSLEEP$ pin is high, the DISABLE pin is low, and $V_M > V_{(UVLO)}$, the device enters the active mode. The $t_{(WAKE)}$ time must elapse before the device is ready for inputs. In this mode, the charge pump and low-side gate regulator are enabled.

7.4.1.4 $nSLEEP$ Reset Pulse

In addition to the CLR_FLT bit in the SPI register, a latched fault can be cleared through a quick $nSLEEP$ pulse. This pulse must be greater than the $nSLEEP$ deglitch time of 5 μs and shorter than 20 μs . If $nSLEEP$ is low for longer than 20 μs , the faults are cleared and the device may or may not shutdown, as shown in the timing diagram (see 图 21). This reset pulse resets any SPI faults and does not affect the status of the charge pump or other functional blocks.



图 21. $nSLEEP$ Reset Pulse

7.5 Programming

7.5.1 Serial Peripheral Interface (SPI) Communication

The SPI version of the device has full duplex, 4-wire synchronous communication. This section describes the SPI protocol, the command structure, and the control and status registers. The device can be connected with the MCU in the following configurations:

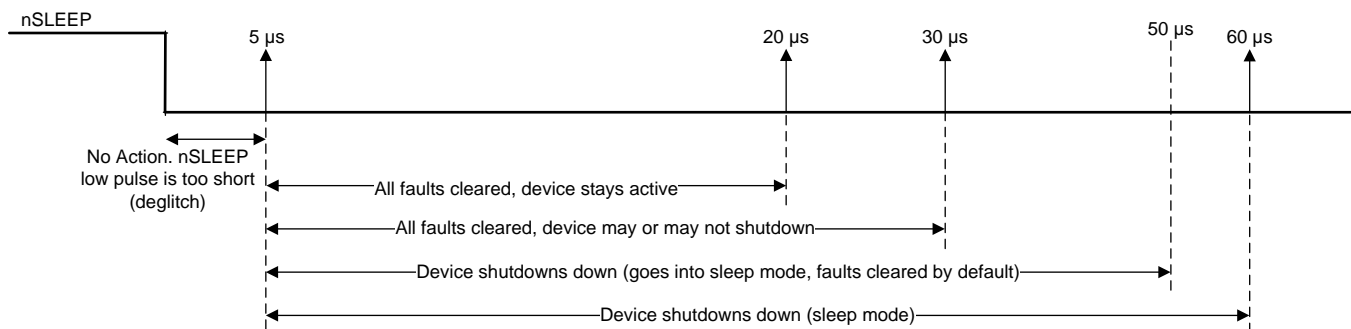
- One slave device
- Multiple slave devices in parallel connection
- Multiple slave devices in series (daisy chain) connection

7.5.1.1 SPI Format

The SDI input data word is 16 bits long and consists of the following format:

- 1 read or write bit, W (bit 14)
- 5 address bits, A (bits 13 through 9)
- 8 data bits, D (bits 7 through 0)

The SDO output-data word is 16 bits long and the first 8 bits make up the Status Register (S1). The Report word (R1) is the content of the register being accessed.

For a write command ($W0 = 0$), the response word on the SDO pin is the data currently in the register being written to.

For a read command ($W0 = 1$), the response word is the data currently in the register being read

Programming (接下页)

表 16. SDI Input Data Word Format

	R/W	ADDRESS						DATA							
B15	B14	B13	B12	B11	B10	B9	B8	B7	B6	B5	B4	B3	B2	B1	B0
0	W0	A4	A3	A2	A1	A0	X	D7	D6	D5	D4	D3	D2	D1	D0

表 17. SDO Output Data Word Format

STATUS								REPORT							
B15	B14	B13	B12	B11	B10	B9	B8	B7	B6	B5	B4	B3	B2	B1	B0
1	1	OTW	UVLO	CPUV	OCF	TSD	OLD	D7	D6	D5	D4	D3	D2	D1	D0

7.5.1.2 SPI for a Single Slave Device

The SPI is used to set device configurations, operating parameters, and read out diagnostic information. The device SPI operates in slave mode. The SPI input-data (SDI) word consists of a 16-bit word, with 8 bits command and 8 bits of data. The SPI output data (SDO) word consists of 8 bits of status register with fault status indication and 8 bits of register data. 图 22 shows the data sequence between the MCU and the SPI slave driver.



图 22. SPI Transaction Between MCU and SPI version of the device

A valid frame must meet the following conditions:

- The SCLK pin must be low when the nSCS pin goes low and when the nSCS pin goes high.
- The nSCS pin should be taken high for at least 500 ns between frames.
- When the nSCS pin is asserted high, any signals at the SCLK and SDI pins are ignored, and the SDO pin is in the high-impedance state (Hi-Z).
- Full 16 SCLK cycles must occur.
- Data is captured on the falling edge of the clock and data is driven on the rising edge of the clock.
- The most-significant bit (MSB) is shifted in and out first.
- If the data word sent to SDI pin is less than 16 bits or more than 16 bits, a frame error occurs and the data word is ignored.
- For a write command, the existing data in the register being written to is shifted out on the SDO pin following the 8-bit command data.

7.5.1.3 SPI for Multiple Slave Devices in Parallel Configuration

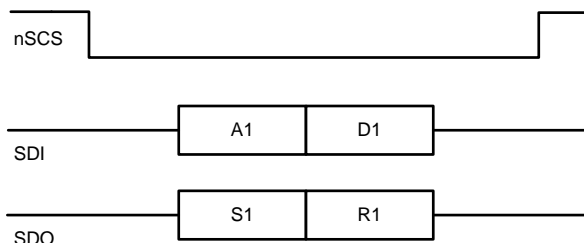
Multiple devices can be connected in parallel as shown in 图 23. In this configuration, all the slave devices can share the same SDI, SDO, and CLK lines from the micro-controller, but has dedicated chip-select pin (CSx) for each device from the micro-controller.

The micro-controller activates the SPI of a given device via that device's chip-select input, the other devices remain inactive for SPI transactions. This configuration helps reduce micro-controller resources for SPI transactions if multiple slave devices are connected to the same micro-controller.

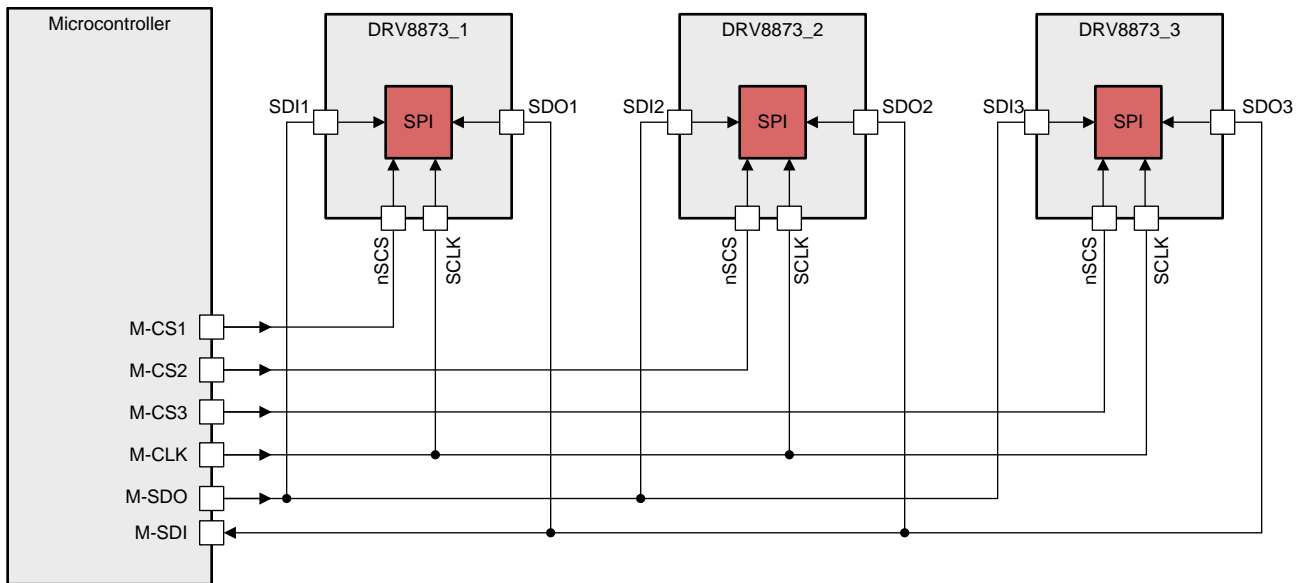

Copyright © 2017, Texas Instruments Incorporated

图 23. Three DRV8873S-Q1 Devices Connected in Parallel Configuration

7.5.1.4 SPI for Multiple Slave Devices in Daisy Chain Configuration

The device can be connected in a daisy chain configuration to keep GPIO ports available when multiple devices are communicating to the same MCU. 图 24 shows the topology when three devices are connected in series.



图 24. Three DRV8873S-Q1 Devices Connected in Daisy Chain

The first device in the chain receives data from the MCU in the following format for 3-device configuration: 2 bytes of header (HDRx) followed by 3 bytes of address (Ax) followed by 3 bytes of data (Dx).

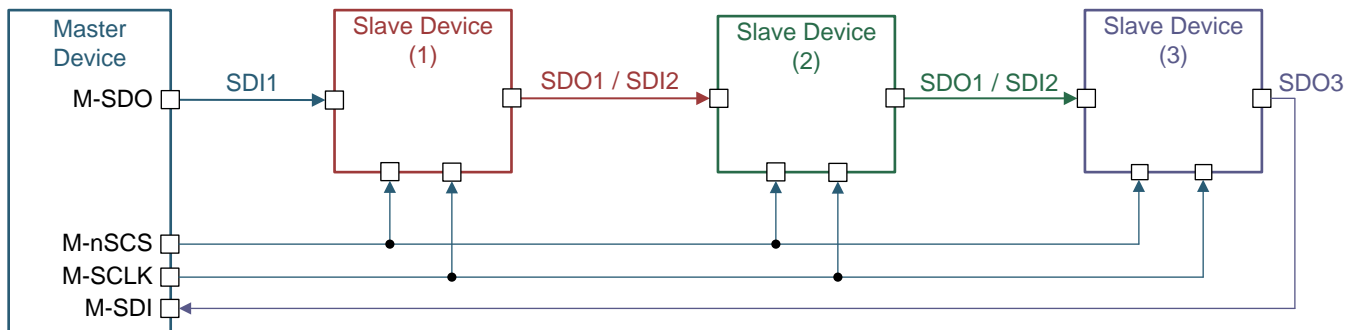

图 25. SPI Frame With Three DRV8873S-Q1 Devices

After the data has been transmitted through the chain, the MCU receives the data string in the following format for 3-device configuration: 3 bytes of status (Sx) followed by 2 bytes of header followed by 3 bytes of report (Rx).

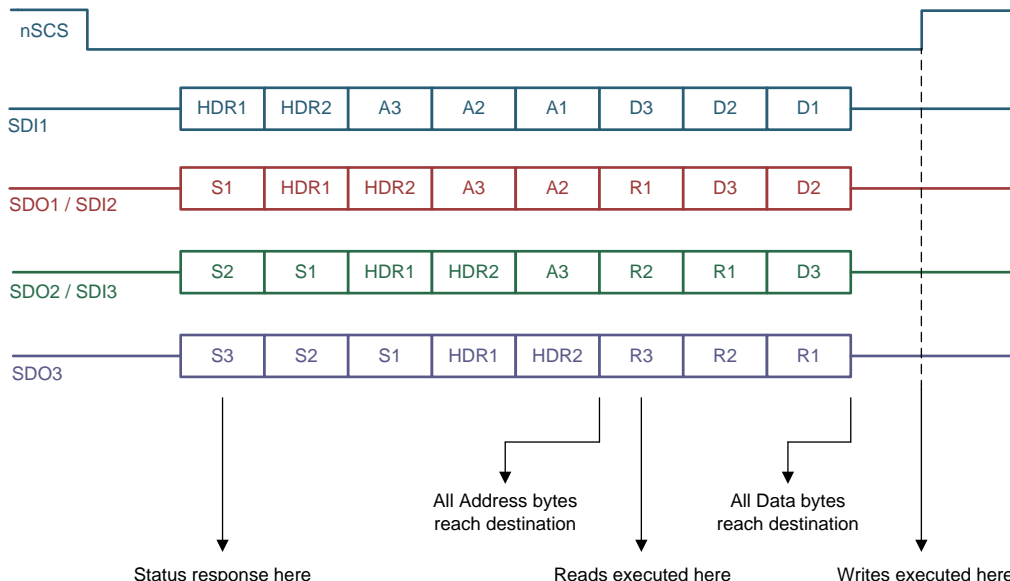

图 26. SPI Data Sequence for Three DRV8873S-Q1 Devices

The header bytes contain information of the number of devices connected in the chain, and a global clear fault command that will clear the fault registers of all the devices on the rising edge of the chip select (nSCS) signal. Header values N5 through N0 are 6 bits dedicated to show the number of devices in the chain. Up to 63 devices can be connected in series for each daisy chain connection.

The 5 LSBs of the HDR2 register are don't care bits that can be used by the MCU to determine integrity of the daisy chain connection. Header bytes must start with 1 and 0 for the two MSBs.

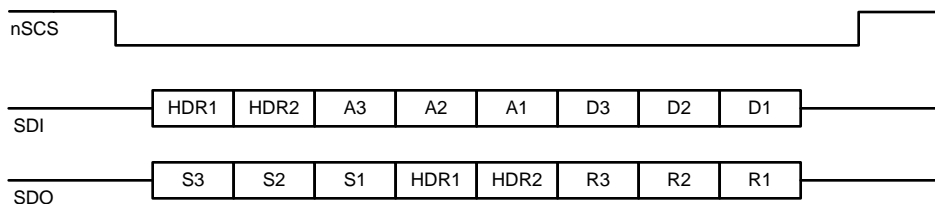

图 27. Header Bytes

The status byte provides information about the fault status register for each device in the daisy chain so that the MCU does not have to initiate a read command to read the fault status from any particular device. This keeps additional read commands for the MCU and makes the system more efficient to determine fault conditions flagged in a device. Status bytes must start with 1 and 1 for the two MSBs.

图 28. Contents of Header, Status, Address, and Data Bytes

When data passes through a device, it determines the position of itself in the chain by counting the number of status bytes it receives followed by the first header byte. For example, in this 3-device configuration, device 2 in the chain receives two status bytes before receiving the HDR1 byte which is then followed by the HDR2 byte.

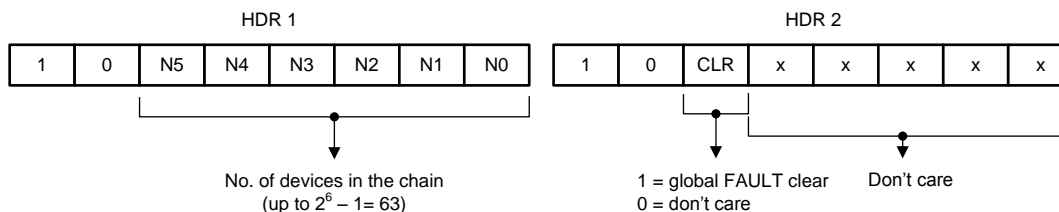
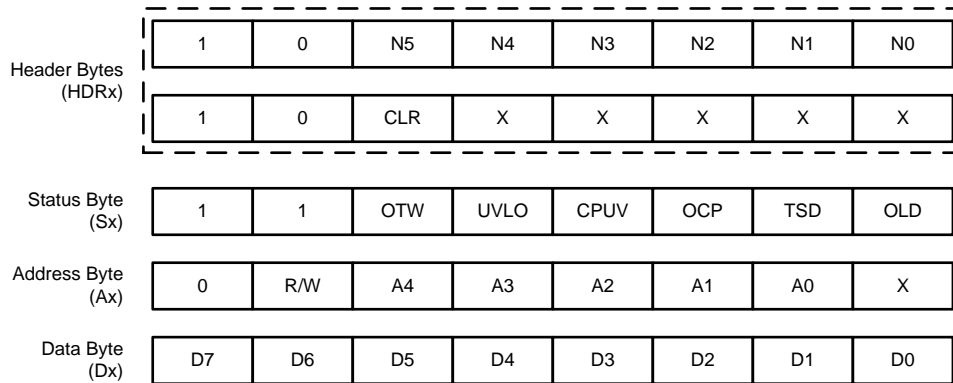
From the two status bytes, the data can determine that its position is second in the chain. From the HDR2 byte, the data can determine how many devices are connected in the chain. In this way, the data only loads the relevant address and data byte in its buffer and bypasses the other bits. This protocol allows for faster communication without adding latency to the system for up to 63 devices in the chain.

The address and data bytes remain the same with respect to a 1-device connection. The report bytes (R1 through R3), as shown in [图 26](#), are the content of the register being accessed.

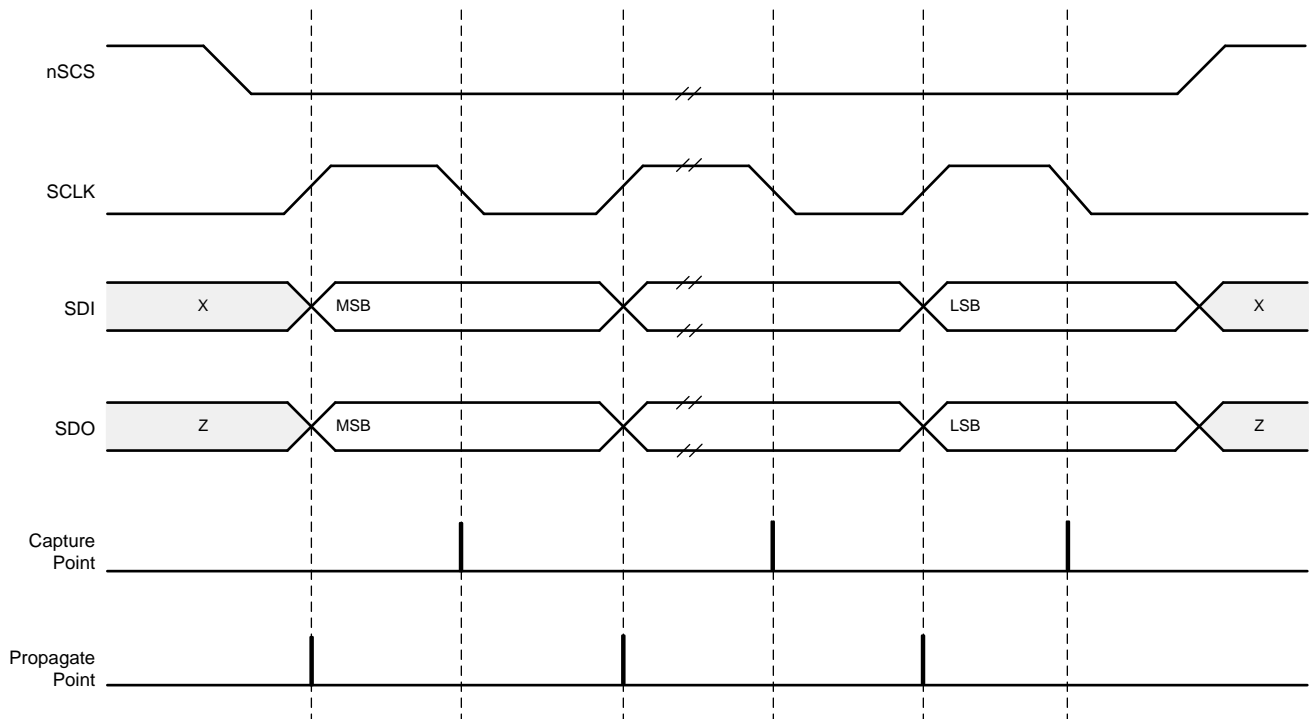
图 29. SPI Transaction

7.6 Register Maps

表 18 lists the memory-mapped registers for the device. All register addresses not listed in 表 18 should be considered as reserved locations and the register contents should not be modified.

表 18. Memory Map

Register Name	7	6	5	4	3	2	1	0	Access Type	Address
FAULT Status	RSVD	FAULT	OTW	UVLO	CPUV	OCP	TSD	OLD	R	0x00
DIAG Status	OL1	OL2	ITRIP1	ITRIP2	OCP_H1	OCP_L1	OCP_H2	OCP_L2	R	0x01
IC1 Control	TOFF		SPL_IN	SR			MODE		RW	0x02
IC2 Control	ITRIP_REP	TSD_MODE	OTW_REP	DIS_CPUV	OCP_TRETRY		OCP_MODE		RW	0x03
IC3 Control	CLR_FLT	LOCK			OUT1_DIS	OUT2_DIS	EN_IN1	PH_IN2	RW	0x04
IC4 Control	RSVD	EN_OLP	OLP_DLY	EN_OLA	ITRIP_LVL		DIS_ITRIP		RW	0x05

Complex bit access types are encoded to fit into small table cells. 表 19 shows the codes that are used for access types in this section.

表 19. Access Type Codes

Access Type	Code	Description
Read Type		
R	R	Read
Write Type		
W	W	Write
Reset or Default Value		
-n		Value after reset or the default value

7.6.1 Status Registers

The status registers are used to reporting warning and fault conditions. Status registers are read-only registers [表 20](#) lists the memory-mapped registers for the status registers. All register offset addresses not listed in [表 20](#) should be considered as reserved locations and the register contents should not be modified.

表 20. Status Registers Summary Table

Address	Register Name	Section
0x00	FAULT status	Go
0x01	DIAG status	Go

7.6.1.1 FAULT Status Register Name (address = 0x00)

FAULT status is shown in [图 30](#) and described in [表 21](#).

Read-only

图 30. FAULT Status Register

7	6	5	4	3	2	1	0
RSVD	FAULT	OTW	UVLO	CPUV	OCP	TSD	OLD
R-0b	R-0b	R-0b	R-0b	R-0b	R-0b	R-0b	R-0b

表 21. FAULT Status Register Field Descriptions

Bit	Field	Type	Default	Description
7	RSVD	R	0b	Reserved
6	FAULT	R	0b	Global FAULT status register. Compliments the nFAULT pin
5	OTW	R	0b	Indicates overtemperature warning
4	UVLO	R	0b	Indicates UVLO fault condition
3	CPUV	R	0b	Indicates charge-pump undervoltage fault condition
2	OCP	R	0b	Indicates an overcurrent condition
1	TSD	R	0b	Indicates an overtemperature shutdown
0	OLD	R	0b	Indicates an open-load detection

7.6.1.2 DIAG Status Register Name (address = 0x01)

DIAG status is shown in [图 31](#) and described in [表 22](#).

Read-only

图 31. DIAG Status Register

7	6	5	4	3	2	1	0
OL1	OL2	ITRIP1	ITRIP2	OCP_H1	OCP_L1	OCP_H2	OCP_L2
R-0b	R-0b	R-0b	R-0b	R-0b	R-0b	R-0b	R-0b

表 22. DIAG Status Register Field Descriptions

Bit	Field	Type	Default	Description
7	OL1	R	0b	Indicates open-load detection on half bridge 1
6	OL2	R	0b	Indicates open-load detection on half bridge 2
5	ITRIP1	R	0b	Indicates the current regulation status of half bridge 1. 0b = Indicates output 1 is not in current regulation 1b = Indicates output 1 is in current regulation

表 22. DIAG Status Register Field Descriptions (接下页)

Bit	Field	Type	Default	Description
4	ITRIP2	R	0b	Indicates the current regulation status of half bridge 2. 0b = Indicates output 2 is not in current regulation 1b = Indicates output 2 is in current regulation
3	OCP_H1	R	0b	Indicates overcurrent fault on the high-side FET of half bridge 1
2	OCP_L1	R	0b	Indicates overcurrent fault on the low-side FET of half bridge 1
1	OCP_H2	R	0b	Indicates overcurrent fault on the high-side FET of half bridge 2
0	OCP_L2	R	0b	Indicates overcurrent fault on the low-side FET of half bridge 2

7.6.2 Control Registers

The IC control registers are used to configure the device. Status registers are read and write capable.

表 23 lists the memory-mapped registers for the control registers. All register offset addresses not listed in 表 23 should be considered as reserved locations and the register contents should not be modified.

表 23. Control Registers Summary Table

Address	Register Name	Section
0x02	IC1 control	Go
0x03	IC2 control	Go
0x04	IC3 control	Go
0x05	IC4 control	Go

7.6.2.1 IC1 Control Register (address = 0x02)

IC1 control is shown in 图 32 and described in 表 24.

Read/Write

图 32. IC1 Control Register

7	6	5	4	3	2	1	0
TOFF		SPI_IN	SR			MODE	
R/W-01b		R/W-0b	R/W-100b			R/W-01b	

表 24. IC1 Control Register Field Descriptions

Bit	Field	Type	Default	Description
7-6	TOFF	R/W	01b	00b = 20 μ s 01b = 40 μs 10b = 60 μ s 11b = 80 μ s
5	SPI_IN	R/W	0b	0b = Outputs follow input pins (INx) 1b = Outputs follow SPI registers EN_IN1 and PH_IN2
4-2	SR	R/W	100b	000b = 53.2-V/ μ s rise time 001b = 34-V/ μ s rise time 010b = 18.3-V/ μ s rise time 011b = 13-V/ μ s rise time 100b = 10.8-V/μs rise time 101b = 7.9-V/ μ s rise time 110b = 5.3-V/ μ s rise time 111b = 2.6-V/ μ s rise time

表 24. IC1 Control Register Field Descriptions (接下页)

Bit	Field	Type	Default	Description
1-0	MODE	R/W	01b	00b = PH/EN 01b = PWM 10b = Independent half bridge 11b = Input disabled; bridge Hi-Z

7.6.2.2 IC2 Control Register (address = 0x03)

IC2 control is shown in 图 33 and described in 表 25.

Read/Write

图 33. IC2 Control Register

7	6	5	4	3	2	1	0
ITRIP_REP	TSD_MODE	OTW_REP	DIS_CPUV	OCP_TRETRY		OCP_MODE	
R/W-0b	R/W-0b	R/W-0b	R/W-0b	R/W-11b		R/W-00b	

表 25. IC2 Control Register Field Descriptions

Bit	Field	Type	Default	Description
7	ITRIP_REP	R/W	0b	0b = ITRIP is not reported on nFAULT or the FAULT bit 1b = ITRIP is reported on nFAULT and the FAULT bit
6	TSD_MODE	R/W	0b	0b = Overtemperature condition causes a latched fault 1b = Overtemperature condition causes an automatic recovery fault
5	OTW_REP	R/W	0b	0b = OTW is not reported on nFAULT or the FAULT bit 1b = OTW is reported on nFAULT and the FAULT bit
4	DIS_CPUV	R/W	0b	0b = Charge pump undervoltage fault is enabled 1b = Charge pump undervoltage fault is disabled
3-2	OCP_TRETRY	R/W	11b	00b = Overcurrent retry time is 0.5 ms 01b = Overcurrent retry time is 1 ms 10b = Overcurrent retry time is 2 ms 11b = Overcurrent retry time is 4 ms
1-0	OCP_MODE	R/W	00b	00b = Overcurrent condition causes a latched fault 01b = Overcurrent condition causes an automatic retrying fault 10b = Overcurrent condition is report only but no action is taken 11b = Overcurrent condition is not reported and no action is taken

7.6.2.3 IC3 Control Register (address = 0x04)

IC3 control is shown in 图 34 and described in 表 26.

Read/Write

图 34. IC3 Control Register

7	6	5	4	3	2	1	0
CLR_FLT	LOCK			OUT1_DIS	OUT2_DIS	EN_IN1	PH_IN2
R/W-0b	R/W-100b			R/W-0b	R/W-0b	R/W-0b	R/W-0b

表 26. IC3 Control Register Field Descriptions

Bit	Field	Type	Default	Description
7	CLR_FLT	R/W	0b	Write a 1b to this bit to clear the fault bits. This bit is automatically reset after a write.
6-4	LOCK	R/W	100b	Write 011b to this register to lock all register settings in the IC1 control register except to these bits and address 0x04, bit 7 (CLR_FLT) Write 100b to this register to unlock all register settings in the IC1 control register
3	OUT1_DIS	R/W	0b	Enabled only in the Independent PWM mode 0b = Half bridge 1 enabled 1b = Half bridge 1 disabled (Hi-Z)
2	OUT2_DIS	R/W	0b	Enabled only in the Independent PWM mode 0b = Half bridge 2 enabled 1b = Half bridge 2 disabled (Hi-Z)
1	EN_IN1	R/W	0b	EN/IN1 bit to control the outputs through SPI (when SPI_IN = 1b)
0	PH_IN2	R/W	0b	PH/IN2 bit to control the outputs through SPI (when SPI_IN = 1b)

7.6.2.4 IC4 Control Register (address = 0x05)

IC4 control is shown in [图 35](#) and described in [表 27](#).

Read/Write

图 35. IC4 Control Register

7	6	5	4	3	2	1	0
RSVD	EN_OLP	OLP_DLY	EN_OLA	ITRIP_LVL		DIS_ITRIP	
R/W-0b	R/W-0b	R/W-0b	R/W-0b	R/W-10b		R/W-00b	

表 27. IC4 Control Register Field Descriptions

Bit	Field	Type	Default	Description
7	RSVD	R/W	0b	Reserved
6	EN_OLP	R/W	0b	Write 1b to run open load diagnostic in standby mode. When open load test is complete EN_OLP returns to 0b (status check)
5	OLP_DLY	R/W	0b	0b = Open load diagnostic delay is 300 μs 1b = Open load diagnostic delay is 1.2 ms
4	EN_OLA	R/W	0b	0b = Open load diagnostic in active mode is disabled 1b = Enable open load diagnostics in active mode
3-2	ITRIP_LVL	R/W	10b	00b = 4 A 01b = 5.4 A 10b = 6.5 A 11b = 7 A
1-0	DIS_ITRIP	R/W	00b	00b = Current regulation is enabled 01b = Current regulation is disabled for OUT1 10b = Current regulation is disabled for OUT2 11b = Current regulation is disabled for both OUT1 and OUT2

8 Application and Implementation

注

Information in the following applications sections is not part of the TI component specification, and TI does not warrant its accuracy or completeness. TI's customers are responsible for determining suitability of components for their purposes. Customers should validate and test their design implementation to confirm system functionality.

8.1 Application Information

The device is used mainly to drive a brushed DC motor. The on-board current regulation allows for limiting the motor current during start-up and stall conditions. The design procedures in the [Typical Application](#) section highlight how to use and configure the SPI version of the device.

8.2 Typical Application

图 36 shows the typical application schematic for the SPI version of the device.



图 36. Typical Application Schematic

Typical Application (接下页)

8.2.1 Design Requirements

表 28 lists the example input parameters for the system design.

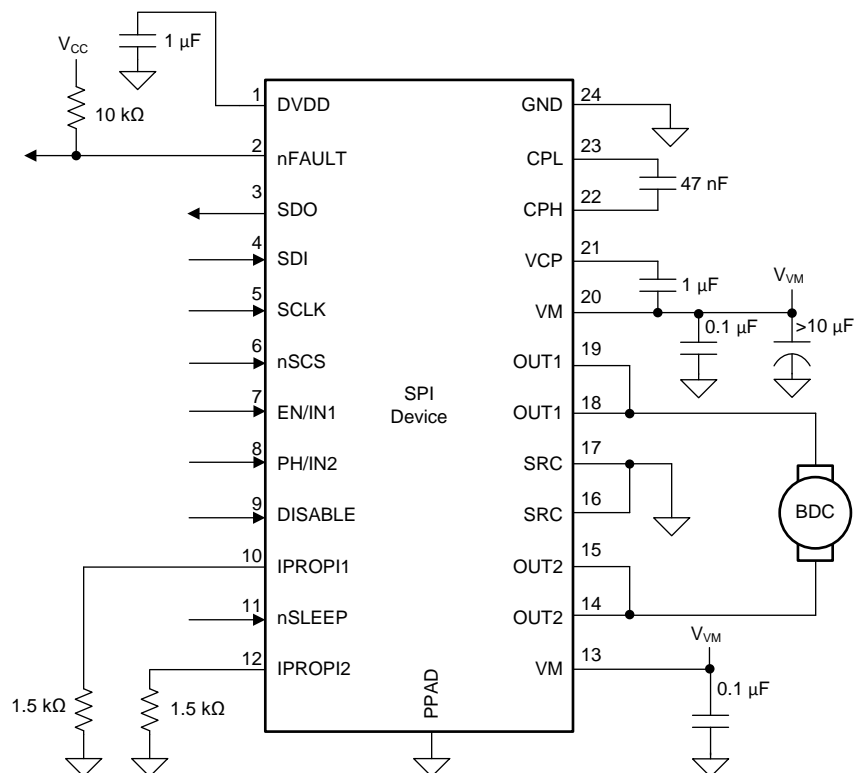
表 28. Design Parameters

DESIGN PARAMETERS	REFERENCE	EXAMPLE VALUE
Supply voltage	VM	13.5 V
Motor RMS current	I _{RMS}	2.5 A
Motor winding inductance	LM	2.9 mH
Motor current trip point	I _{TRIP}	6.5 A
PWM frequency	f _{PWM}	10 kHz
Sense resistor	R _{SENSE}	1.5 kΩ
Rise and fall times (slew rate)	t _{SR}	1 μs

8.2.1.1 Motor Voltage

The motor voltage used depends on the ratings of the motor selected and the desired RPM. A higher voltage spins a brushed DC motor faster with the same PWM duty cycle applied to the power FETs. A higher voltage also increases the rate of current change through the inductive motor windings.

8.2.1.2 Drive Current and Power Dissipation

The current path is through the high-side sourcing power driver, motor winding, and low-side sinking power driver. The amount of current the device can drive depends on the power dissipation without going into thermal shutdown. The amount of current that can be power dissipation losses in one source and sink power driver are calculated in 公式 2.

$$P_D = (I_{RMS})^2 \times (R_{DS(on)High-side} + R_{DS(on)Low-side}) \quad (2)$$

The I_{OUT} current is equal to the average current drawn by the DC motor. At 25°C ambient temperature, the power dissipation becomes (2.5 A)² × (150 mΩ) = 0.94 W.

The temperature that the device reaches depends on the thermal resistance to the air and PCB. Soldering the device PowerPAD to the PCB ground plane, with vias to the top and bottom board layers, is important to dissipate heat into the PCB and reduce the device temperature. In the example used here, the device had an effective thermal resistance R_{θJA} of 27.8°C/W. The junction temperature T_J value becomes as shown in 公式 3.

$$T_J = T_A + (P_D \times R_{\theta JA}) = 25^\circ\text{C} + (0.94 \text{ W} \times 27.8^\circ\text{C/W}) = 51^\circ\text{C} \quad (3)$$

注

The values of R_{DS(on)} increases with temperature, so as the device heats, the power dissipation increases. This fact must be taken into consideration when sizing the heatsink.

At start-up and fault conditions, the current flowing through the motor is much higher than normal running current; these peak currents and their duration must also be considered. High PWM frequency also results in higher switching losses. Typically, switching the inputs at 100 kHz compared to 10 kHz causes 20% more power loss in heat.

Power dissipation in the device is dominated by the power dissipated of the internal MOSFET resistance. The maximum amount of power that can be dissipated in the device is dependent on ambient temperature and heatsinking.

Total power dissipation for the device is composed of three main components. These are the quiescent supply current dissipation, the power MOSFET switching losses, and the power MOSFET R_{DS(ON)} (conduction) losses. While other factors may contribute additional power losses, these other items are typically insignificant compared to the three main items.

$$P_{TOT} = P_{VM} + P_{SW} + P_D \quad (4)$$

P_{VM} can be calculated from the nominal supply voltage (V_M) and the supply current (I_{VM}) in active mode.

$$P_{VM} = V_M \times I_{VM} = 13.5 \text{ V} \times 5 \text{ mA} = 67.5 \text{ mW} \quad (5)$$

P_{SW} can be calculated from the nominal supply voltage (V_M), average output current (I_{RMS}), switching frequency (f_{PWM}) and the device output rise and fall times (t_{SR}) time specifications.

$$P_{SW} = P_{SW_RISE} + P_{SW_FALL} = 0.17\text{ W} + 0.17\text{ W} = 0.34\text{ W} \tag{6}$$

$$P_{SW_RISE} = 0.5 \times V_M \times I_{RMS} \times t_{SR} \times f_{PWM} = 0.5 \times 13.5\text{ V} \times 2.5\text{ A} \times 1\ \mu\text{s} \times 10\text{ kHz} = 0.17\text{ W} \tag{7}$$

$$P_{SW_FALL} = 0.5 \times V_M \times I_{RMS} \times t_{SR} \times f_{PWM} = 0.5 \times 13.5\text{ V} \times 2.5\text{ A} \times 1\ \mu\text{s} \times 10\text{ kHz} = 0.17\text{ W} \tag{8}$$

Therefore, total power dissipation (P_{TOT}) at 25°C ambient temperature becomes = $P_{VM} + P_{SW} + P_D = 67.5\text{ mW} + 0.34\text{ W} + 0.94\text{ W} = 1.35\text{ W}$

P_{TOT} makes the junction temperature (T_J) of the device to be

$$T_J = T_A + (P_{TOT} \times R_{\theta JA}) = 25^\circ\text{C} + (1.35\text{ W} \times 27.8^\circ\text{C/W}) = 63^\circ\text{C} \tag{9}$$

The power dissipation from power MOSFET switching losses and quiescent supply current dissipation results is approximately 12°C rise in the junction temperature (different between 公式 9 and 公式 3). Care must be taken when doing the PCB layout and heatsinking the motor driver device so that the thermal characteristics are properly managed.



图 37. PCB Model (4-Layer PCB Shown, 2-Layer PCB Has No Vias)



图 38. 4-Layer PCB

Junction-to-Ambient Thermal Resistance vs Copper Area

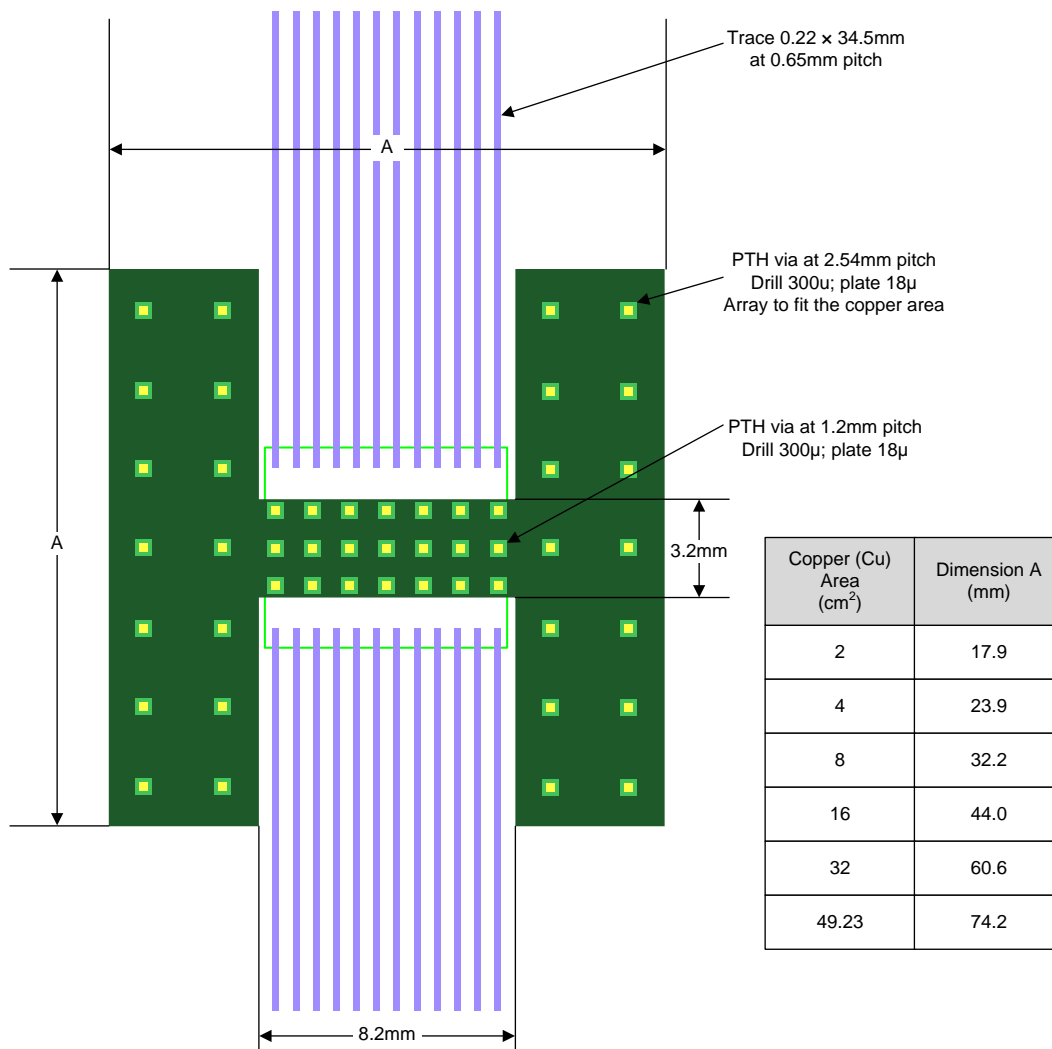

图 39. 4-Layer PCB

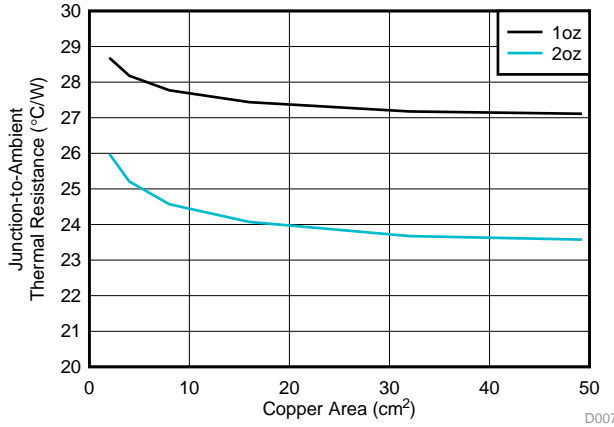
Junction-to-Board Characterization Parameter vs Copper Area

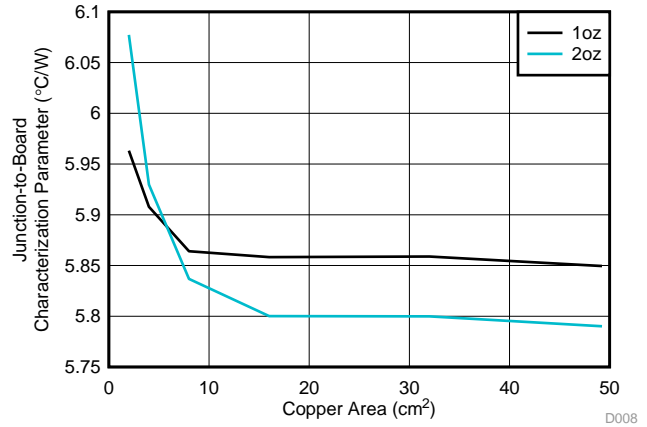

图 40. 2-Layer PCB (No Vias)

Junction-to-Ambient Thermal Resistance vs Copper Area

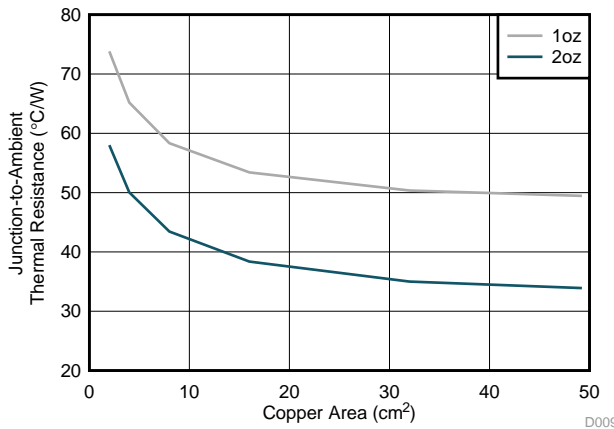

图 41. 2-Layer PCB (No Vias)

Junction-to-Board Characterization Parameter vs Copper Area

8.2.1.3 Sense Resistor

For optimal performance, the sense resistor must have the following features:

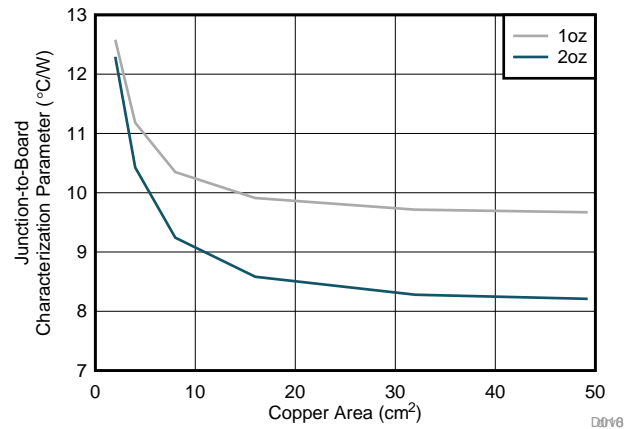
- Surface-mount device
- Low inductance
- Placed closely to the motor driver device

Use [公式 10](#) to calculate the power dissipation (P_D) of the sense resistor.

$$P_D = (I_{(RMS)} / k)^2 \times R_{(SENSE)} \quad (10)$$

In this example, for the RMS motor current is 2.5 A, the sense resistor of 1.5 k Ω dissipates approximately 7.5 mW of power. The power quickly increases with higher current levels. Resistors typically have a rated power within some ambient temperature range, along with a derated power curve for high ambient temperatures. When a PCB is shared with other components that generate heat, the system designer should add margin. Measuring the actual sense resistor temperature in a final system is best.

8.2.2 Detailed Design Procedure

8.2.2.1 Thermal Considerations

The device has thermal shutdown (TSD) at 165°C (minimum). If the die temperature exceeds this TSD threshold, the device will be disabled until the temperature drops below the temperature hysteresis level.

Any tendency of the device to enter TSD is an indication of either excessive power dissipation, insufficient heatsinking, or too high of an ambient temperature.

8.2.2.2 Heatsinking

The PowerPAD package uses an exposed pad to remove heat from the device. For proper operation, this pad must be thermally connected to copper on the PCB to dissipate heat. On a multi-layer PCB with a ground plane, this connection can be accomplished by adding a number of vias to connect the thermal pad to the ground plane.

On PCBs without internal planes, a copper area can be added on either side of the PCB to dissipate heat. If the copper area is on the opposite side of the PCB from the device, thermal vias are used to transfer the heat between top and bottom layers.

For details about how to design the PCB, refer to the [PowerPAD™ Thermally Enhanced Package application report](#), and the [PowerPAD™ Made Easy application report](#), available at www.ti.com. In general, the more copper area that can be provided, the more power can be dissipated.

8.2.3 Application Curves



图 42. Overcurrent (OCP) Detection



图 43. Current Regulation (ITRIP)

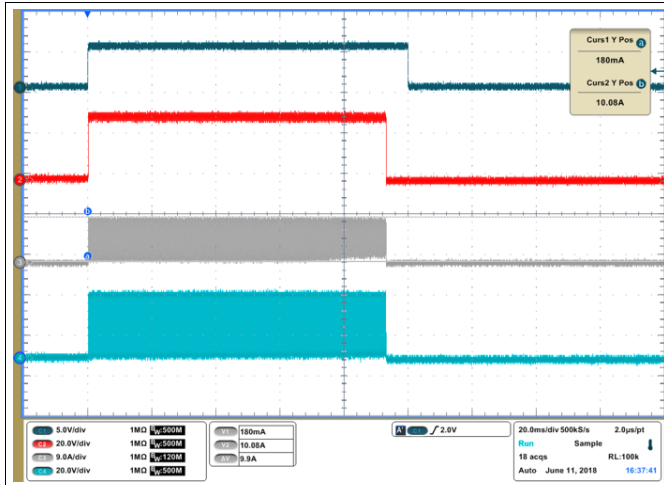

图 44. ITRIP Across TOFF and Load Current

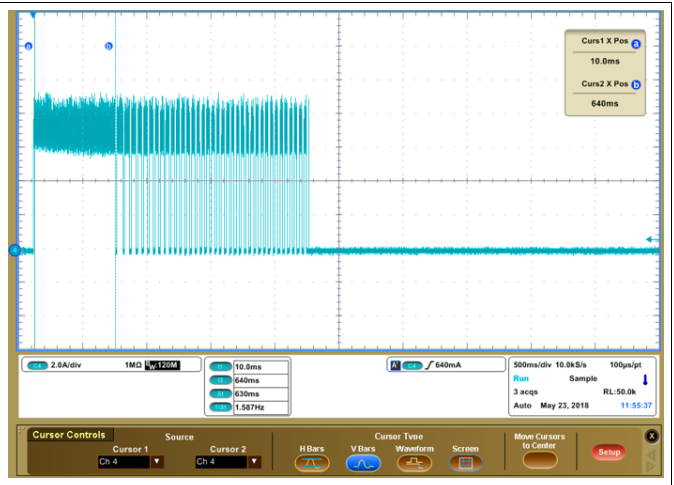

图 45. Motor Motion at Different Speeds

9 Power Supply Recommendations

The device is designed to operate with an input voltage supply (VM) range from 4.5 V to 40 V. A 0.1- μF ceramic capacitor rated for VM must be placed as close to the device as possible. Also, an appropriately sized bulk capacitor must be placed on the VM pin.

9.1 Bulk Capacitance Sizing

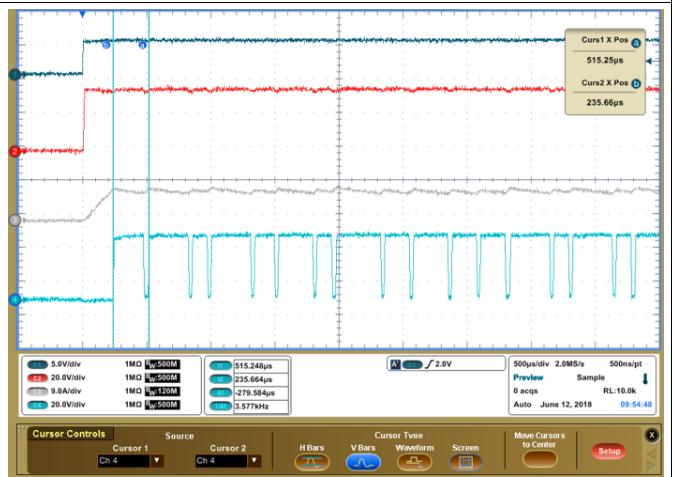
Bulk capacitance sizing is an important factor in motor drive system design. It is beneficial to have more bulk capacitance, while the disadvantages are increased cost and physical size.

The amount of local capacitance needed depends on a variety of factors including:

- The highest current required by the motor system.
- The capacitance of the power supply and the ability of the power supply to source current.
- The amount of parasitic inductance between the power supply and motor system.
- The acceptable voltage ripple.
- The type of motor used (brushed DC, brushless DC, and stepper).
- The motor braking method.

The inductance between the power supply and motor drive system limits the rate that current can change from the power supply. If the local bulk capacitance is too small, the system responds to excessive current demands or dumps from the motor with a change in voltage. When sufficient bulk capacitance is used, the motor voltage remains stable, and high current can be quickly supplied.

The data sheet provides a recommended value, but system-level testing is required to determine the appropriate sized bulk capacitor.



图 46. Example Setup of Motor Drive System With External Power Supply

The voltage rating for bulk capacitors should be higher than the operating voltage to provide a margin for cases when the motor transfers energy to the supply.

10 Layout

10.1 Layout Guidelines

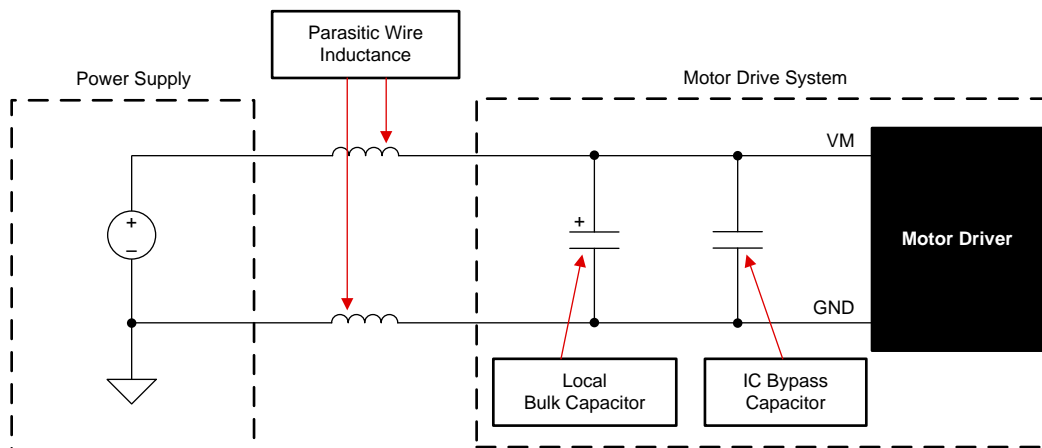
Each VM pin must be bypassed to ground using low-ESR ceramic bypass capacitors with recommended values of 0.1 μF rated for VM. These capacitors should be placed as close to the VM pins as possible with a thick trace or ground plane connection to the device GND pin.

Additional bulk capacitance is required to bypass the high current path. This bulk capacitance should be placed such that it minimizes the length of any high current paths. The connecting metal traces should be as wide as possible, with numerous vias connecting PCB layers. These practices minimize inductance and allow the bulk capacitor to deliver high current.

Place a low-ESR ceramic capacitor between the CPL and CPH pins. This capacitor should be 47 nF, rated for VM, and be of type X5R or X7R. Additionally, place a low-ESR ceramic capacitor between the VCP and VM pins. This capacitor should be 1 μF , rated for 16 V, and be of type X5R or X7R.

The current sense resistors should be placed as close as possible to the device pins to minimize trace inductance between the device pin and resistors.

10.2 Layout Example



图 47. Layout Example

11 器件和文档支持

11.1 文档支持

11.1.1 相关文档

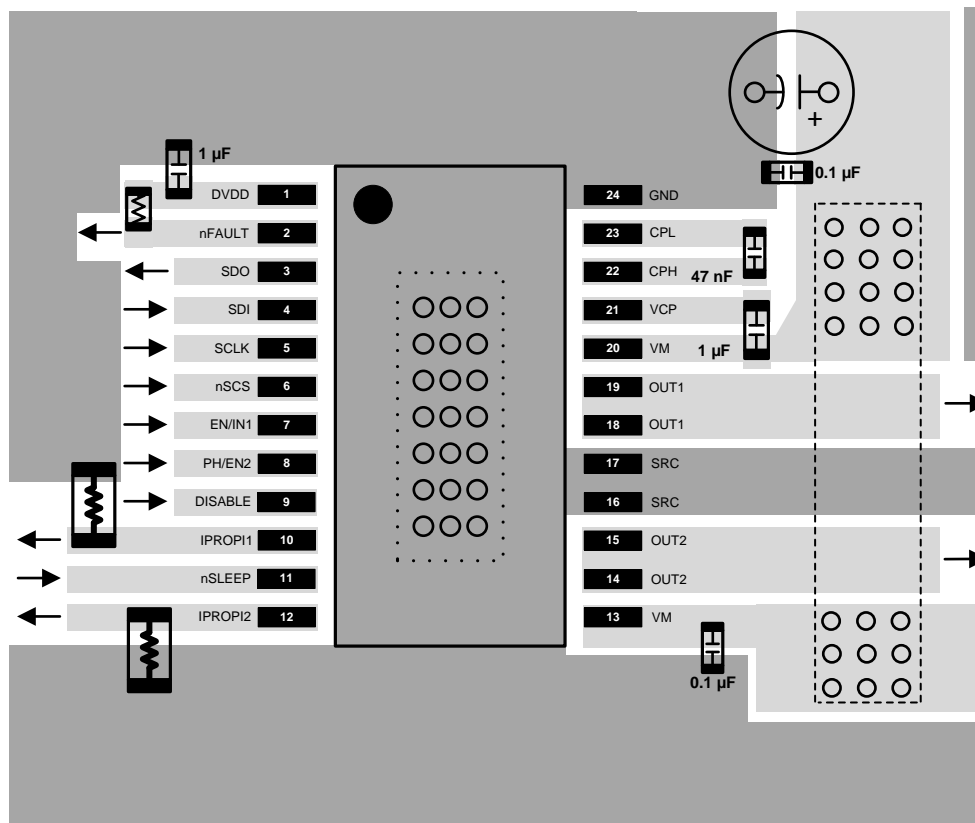
请参阅如下相关文档：

- 德州仪器 (TI), 《[计算电机驱动器的功耗](#)》应用报告
- 德州仪器 (TI), 《[串行外设接口的菊链实现](#)》应用报告
- 德州仪器 (TI), 《[DRV8873x-Q1EVM 用户指南](#)》
- 德州仪器 (TI), 《[DRV8873x-Q1EVM GUI 用户指南](#)》
- 德州仪器 (TI), 《[工业电机驱动解决方案指南](#)》
- 德州仪器 (TI), 《[PowerPAD™ 热增强型封装](#)》应用报告
- 德州仪器 (TI), 《[PowerPAD™ 速成](#)》应用报告
- 德州仪器 (TI), 《[采用 MSP430™ 的传感器式三相 BLDC 电机控制](#)》应用报告
- 德州仪器 (TI), 《[了解电机驱动器电流额定值](#)》应用报告

11.2 接收文档更新通知

要接收文档更新通知，请导航至 TI.com.cn 上的器件产品文件夹。单击右上角的 [通知我](#) 进行注册，即可每周接收产品信息更改摘要。有关更改的详细信息，请查看任何已修订文档中包含的修订历史记录。

11.3 社区资源

下列链接提供到 TI 社区资源的连接。链接的内容由各个分销商“按照原样”提供。这些内容并不构成 TI 技术规范，并且不一定反映 TI 的观点；请参阅 TI 的 [《使用条款》](#)。

TI E2E™ 在线社区 [TI 的工程师对工程师 \(E2E\) 社区](#)。此社区的创建目的在于促进工程师之间的协作。在 e2e.ti.com 中，您可以咨询问题、分享知识、拓展思路并与同行工程师一道帮助解决问题。

设计支持 [TI 参考设计支持](#) 可帮助您快速查找有帮助的 E2E 论坛、设计支持工具以及技术支持的联系信息。

11.4 商标

PowerPAD, MSP430, E2E are trademarks of Texas Instruments.
All other trademarks are the property of their respective owners.

11.5 静电放电警告



ESD 可能会损坏该集成电路。德州仪器 (TI) 建议通过适当的预防措施处理所有集成电路。如果不遵守正确的处理措施和安装程序，可能会损坏集成电路。

ESD 的损坏小至导致微小的性能降级，大至整个器件故障。精密的集成电路可能更容易受到损坏，这是因为非常细微的参数更改都可能会导致器件与其发布的规格不相符。

11.6 术语表

SLYZ022 — *TI 术语表*。

这份术语表列出并解释术语、缩写和定义。

12 机械、封装和可订购信息

以下页面包含机械、封装和可订购信息。这些信息是指定器件的最新可用数据。数据如有变更，恕不另行通知，且不会对此文档进行修订。如需获取此数据表的浏览器版本，请查阅左侧的导航栏。

PACKAGING INFORMATION

Orderable Device	Status (1)	Package Type	Package Drawing	Pins	Package Qty	Eco Plan (2)	Lead finish/ Ball material (6)	MSL Peak Temp (3)	Op Temp (°C)	Device Marking (4/5)	Samples
DRV8873HPWPRQ1	ACTIVE	HTSSOP	PWP	24	2000	RoHS & Green	NIPDAU	Level-3-260C-168 HR	-40 to 125	8873HQ	Samples
DRV8873SPWPRQ1	ACTIVE	HTSSOP	PWP	24	2000	RoHS & Green	NIPDAU	Level-3-260C-168 HR	-40 to 125	8873SQ	Samples

(1) The marketing status values are defined as follows:

ACTIVE: Product device recommended for new designs.

LIFEBUY: TI has announced that the device will be discontinued, and a lifetime-buy period is in effect.

NRND: Not recommended for new designs. Device is in production to support existing customers, but TI does not recommend using this part in a new design.

PREVIEW: Device has been announced but is not in production. Samples may or may not be available.

OBSELETE: TI has discontinued the production of the device.

(2) **RoHS:** TI defines "RoHS" to mean semiconductor products that are compliant with the current EU RoHS requirements for all 10 RoHS substances, including the requirement that RoHS substance do not exceed 0.1% by weight in homogeneous materials. Where designed to be soldered at high temperatures, "RoHS" products are suitable for use in specified lead-free processes. TI may reference these types of products as "Pb-Free".

RoHS Exempt: TI defines "RoHS Exempt" to mean products that contain lead but are compliant with EU RoHS pursuant to a specific EU RoHS exemption.

Green: TI defines "Green" to mean the content of Chlorine (Cl) and Bromine (Br) based flame retardants meet JS709B low halogen requirements of <=1000ppm threshold. Antimony trioxide based flame retardants must also meet the <=1000ppm threshold requirement.

(3) MSL, Peak Temp. - The Moisture Sensitivity Level rating according to the JEDEC industry standard classifications, and peak solder temperature.

(4) There may be additional marking, which relates to the logo, the lot trace code information, or the environmental category on the device.

(5) Multiple Device Markings will be inside parentheses. Only one Device Marking contained in parentheses and separated by a "~" will appear on a device. If a line is indented then it is a continuation of the previous line and the two combined represent the entire Device Marking for that device.

(6) Lead finish/Ball material - Orderable Devices may have multiple material finish options. Finish options are separated by a vertical ruled line. Lead finish/Ball material values may wrap to two lines if the finish value exceeds the maximum column width.

Important Information and Disclaimer:The information provided on this page represents TI's knowledge and belief as of the date that it is provided. TI bases its knowledge and belief on information provided by third parties, and makes no representation or warranty as to the accuracy of such information. Efforts are underway to better integrate information from third parties. TI has taken and continues to take reasonable steps to provide representative and accurate information but may not have conducted destructive testing or chemical analysis on incoming materials and chemicals. TI and TI suppliers consider certain information to be proprietary, and thus CAS numbers and other limited information may not be available for release.

In no event shall TI's liability arising out of such information exceed the total purchase price of the TI part(s) at issue in this document sold by TI to Customer on an annual basis.

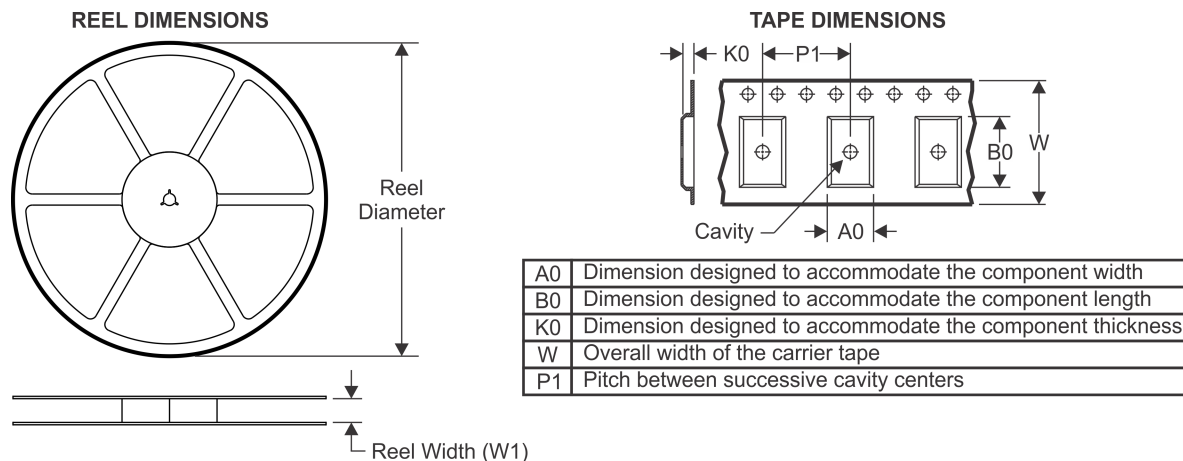
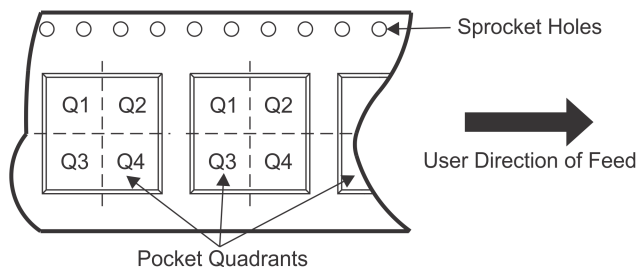
TAPE AND REEL INFORMATION

QUADRANT ASSIGNMENTS FOR PIN 1 ORIENTATION IN TAPE

*All dimensions are nominal

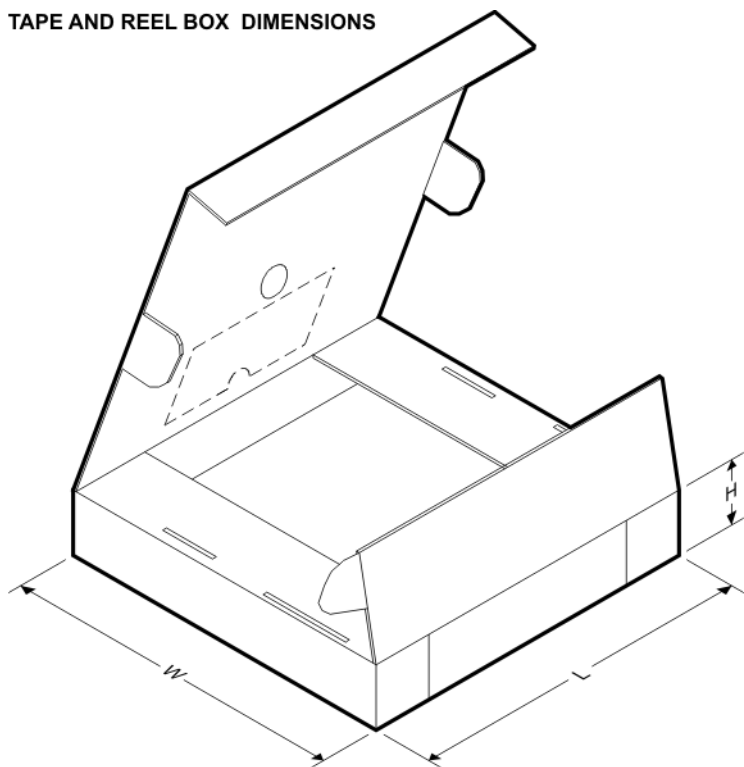
Device	Package Type	Package Drawing	Pins	SPQ	Reel Diameter (mm)	Reel Width W1 (mm)	A0 (mm)	B0 (mm)	K0 (mm)	P1 (mm)	W (mm)	Pin1 Quadrant
DRV8873SPWPRQ1	HTSSOP	PWP	24	2000	330.0	16.4	6.95	8.3	1.6	8.0	16.0	Q1

TAPE AND REEL BOX DIMENSIONS

*All dimensions are nominal

Device	Package Type	Package Drawing	Pins	SPQ	Length (mm)	Width (mm)	Height (mm)
DRV8873SPWPRQ1	HTSSOP	PWP	24	2000	350.0	350.0	43.0

GENERIC PACKAGE VIEW

PWP 24

PowerPAD™ TSSOP - 1.2 mm max height

4.4 x 7.6, 0.65 mm pitch

PLASTIC SMALL OUTLINE

This image is a representation of the package family, actual package may vary.
Refer to the product data sheet for package details.

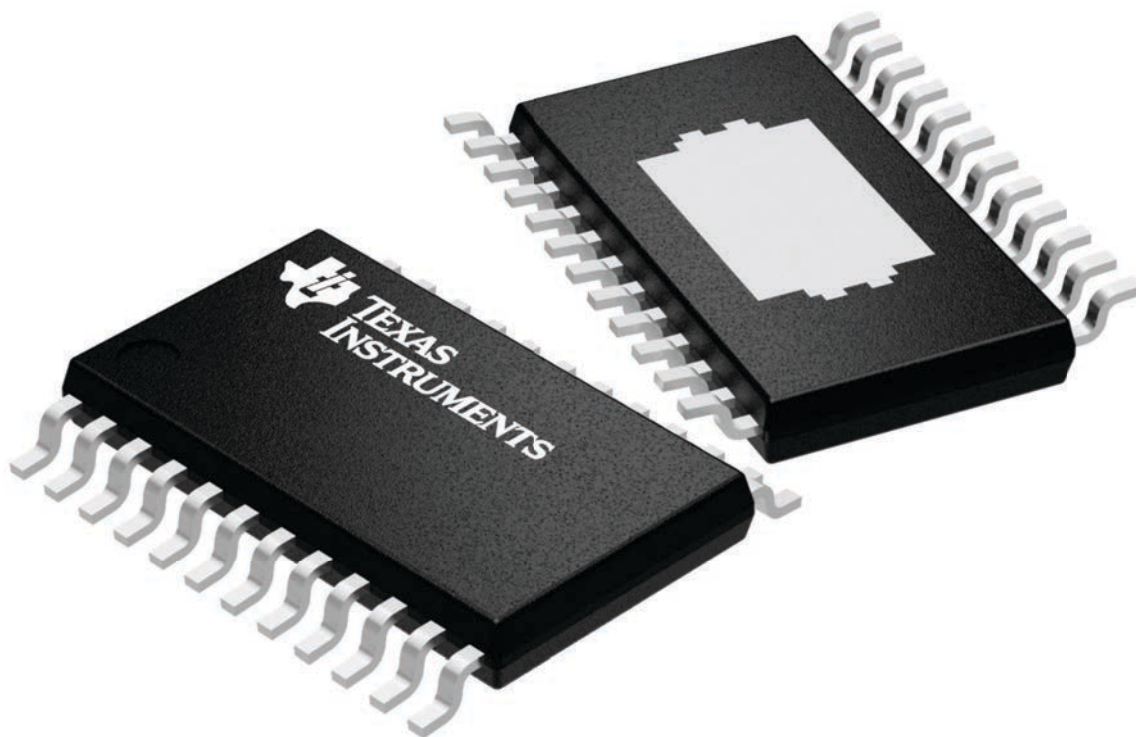

4224742/B

PWP0024J

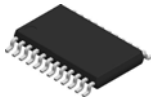

PACKAGE OUTLINE

PowerPAD™ TSSOP - 1.2 mm max height

SMALL OUTLINE PACKAGE

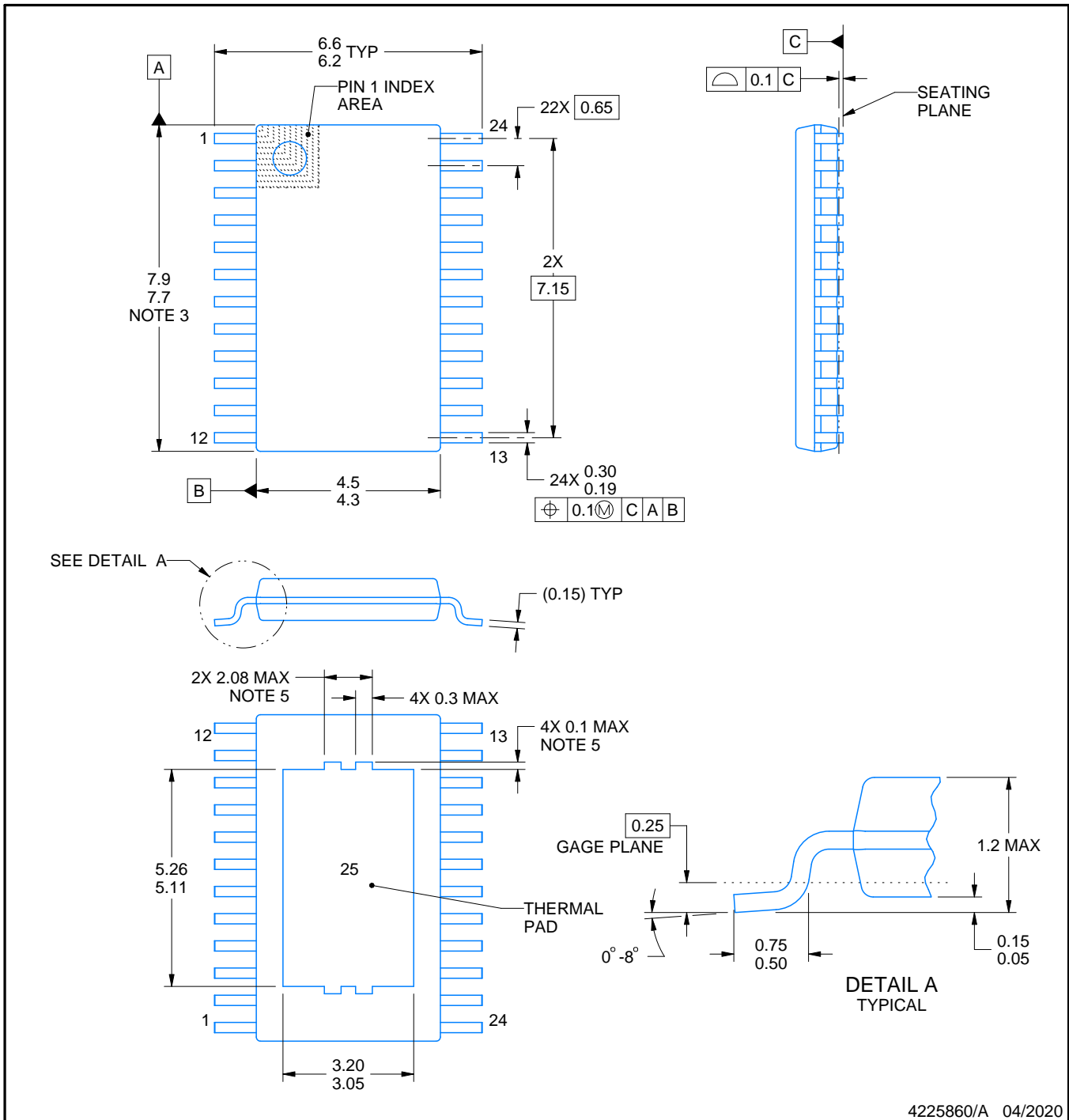

4225860/A 04/2020

NOTES:

PowerPAD is a trademark of Texas Instruments.

1. All linear dimensions are in millimeters. Any dimensions in parenthesis are for reference only. Dimensioning and tolerancing per ASME Y14.5M.
2. This drawing is subject to change without notice.
3. This dimension does not include mold flash, protrusions, or gate burrs. Mold flash, protrusions, or gate burrs shall not exceed 0.15 mm per side.
4. Reference JEDEC registration MO-153.
5. Features may differ or may not be present.

EXAMPLE STENCIL DESIGN

PWP0024J

PowerPAD™ TSSOP - 1.2 mm max height

SMALL OUTLINE PACKAGE

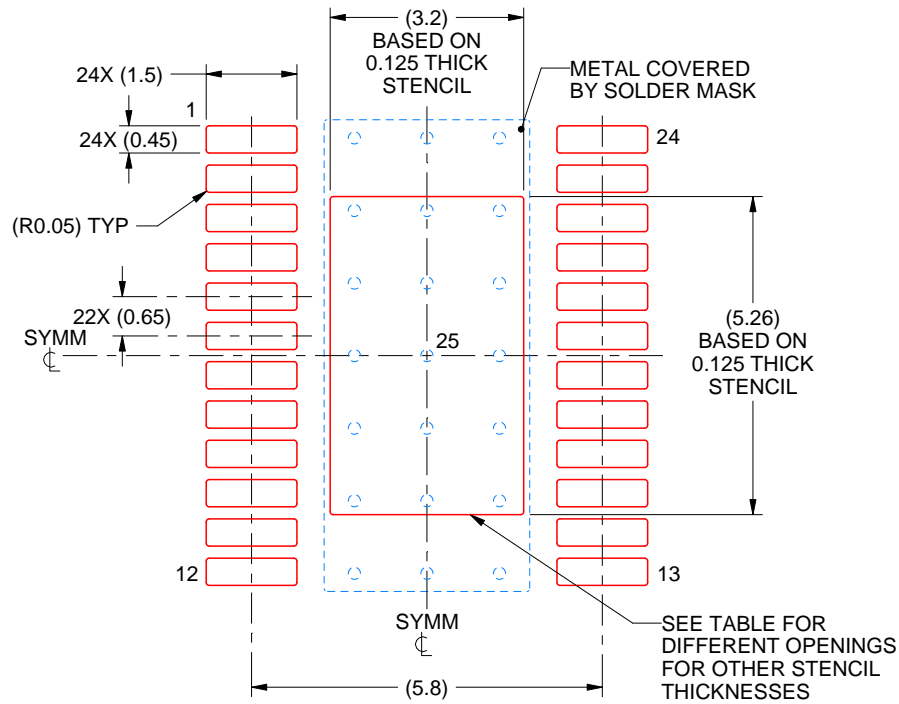

SOLDER PASTE EXAMPLE
 BASED ON 0.125 mm THICK STENCIL
 SCALE: 8X

STENCIL THICKNESS	SOLDER STENCIL OPENING
0.1	3.58 X 5.88
0.125	3.20 X 5.26 (SHOWN)
0.15	2.92 X 4.80
0.175	2.70 X 4.45

4225860/A 04/2020

NOTES: (continued)

11. Laser cutting apertures with trapezoidal walls and rounded corners may offer better paste release. IPC-7525 may have alternate design recommendations.
12. Board assembly site may have different recommendations for stencil design.

重要声明和免责声明

TI“按原样”提供技术和可靠性数据（包括数据表）、设计资源（包括参考设计）、应用或其他设计建议、网络工具、安全信息和其他资源，不保证没有瑕疵且不做任何明示或暗示的担保，包括但不限于对适销性、某特定用途方面的适用性或不侵犯任何第三方知识产权的暗示担保。

这些资源可供使用 TI 产品进行设计的熟练开发人员使用。您将自行承担以下全部责任：(1) 针对您的应用选择合适的 TI 产品，(2) 设计、验证并测试您的应用，(3) 确保您的应用满足相应标准以及任何其他功能安全、信息安全、监管或其他要求。

这些资源如有变更，恕不另行通知。TI 授权您仅可将这些资源用于研发本资源所述的 TI 产品的应用。严禁对这些资源进行其他复制或展示。您无权使用任何其他 TI 知识产权或任何第三方知识产权。您应全额赔偿因在这些资源的使用中对 TI 及其代表造成的任何索赔、损害、成本、损失和债务，TI 对此概不负责。

TI 提供的产品受 [TI 的销售条款](#) 或 [ti.com](#) 上其他适用条款/TI 产品随附的其他适用条款的约束。TI 提供这些资源并不会扩展或以其他方式更改 TI 针对 TI 产品发布的适用的担保或担保免责声明。

TI 反对并拒绝您可能提出的任何其他或不同的条款。

邮寄地址：Texas Instruments, Post Office Box 655303, Dallas, Texas 75265

Copyright © 2022，德州仪器 (TI) 公司