

SN74HC595B 采用三态输出寄存器的 8 位移位寄存器

1 特性

- 8 位串行输入/并行输出移位寄存器
- 采用超小型逻辑四方扁平无引线 (QFN) 封装 (最大高度为 0.5mm)
- 独立于 V_{CC} 的输入过压容差
- 2V 至 6V 的宽运行电压范围
- 高电流三态输出最多可驱动 15 个低功耗肖特基晶体管-晶体管逻辑器件 (LSTTL) 负载
- 低功耗: I_{CC} 为 80 μ A (最大值)
- $t_{pd} = 13$ ns (典型值)
- ± 6 mA 输出驱动 (电压为 5V 时)
- 低输入电流: 1 μ A (最大值)
- 移位寄存器具有直接清零功能
- 运行温度为 -55°C 至 125°C

2 应用

- 网络交换机
- 工厂自动化
- 移动可穿戴设备
- 工业楼宇自动化
- 电力基础设施
- 发光二极管 (LED) 显示屏
- 服务器

3 说明

SN74HC595B 器件包含一个 8 位串行输入/并行输出移位寄存器, 可将数据馈入 8 位 D 类存储寄存器。存储寄存器具有并行三态输出。移位寄存器和存储寄存器均具有独立时钟。移位寄存器具有一个直接覆盖清零 (SRCLR) 输入以及用于级联结构的串行 (SER) 输入和串行输出。当输出使能 (OE) 输入置为高电平时, 除 Q_H 之外的所有输出均将置于高阻抗状态。

表 1. 器件信息

部件号	封装 (引脚)	封装尺寸 (标称值)
SN74HC595BRWN	X1QFN (16)	2.50mm x 2.50mm

(1) 要了解所有可用封装, 请参见数据表末尾的可订购产品附录。



图 1. 逻辑图 (正逻辑)

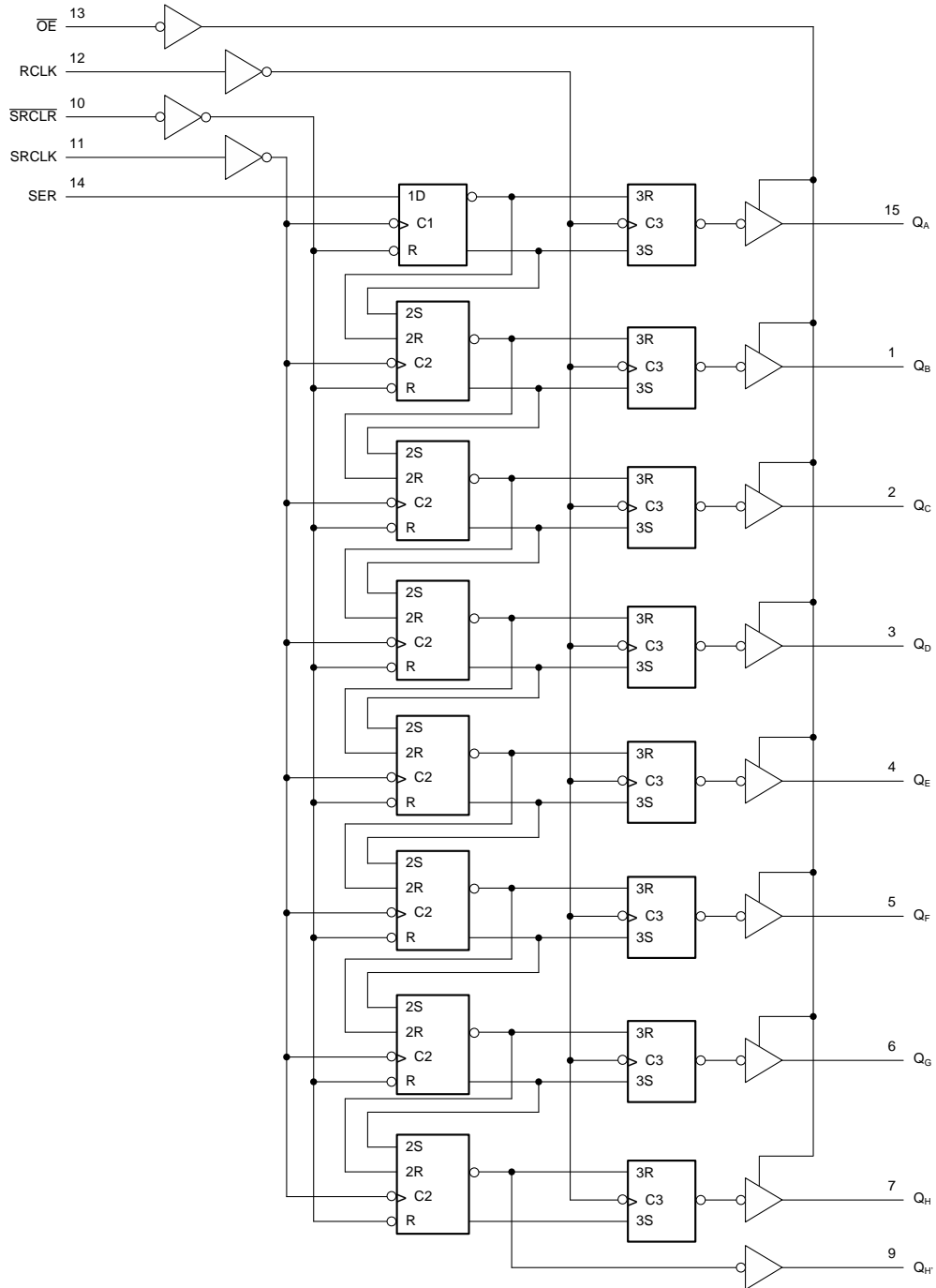

目录

1	特性	1	7.2	Functional Block Diagram	13
2	应用	1	7.3	Feature Description	14
3	说明	1	7.4	Device Functional Modes	14
4	Pin Configuration and Functions	4	8	Application and Implementation	15
5	Specifications	5	8.1	Application Information	15
5.1	Absolute Maximum Ratings	5	8.2	Typical Application	15
5.2	ESD Ratings	5	9	Power Supply Recommendations	17
5.3	Recommended Operating Conditions	5	10	Layout	17
5.4	Thermal Information	6	10.1	Layout Guidelines	17
5.5	Electrical Characteristics	6	10.2	Layout Example	17
5.6	Timing Requirements	7	11	器件和文档支持	18
5.7	Switching Characteristics	8	11.1	文档支持	18
5.8	Operating Characteristics	9	11.2	社区资源	18
5.9	Typical Characteristics	10	11.3	Trademarks	18
6	Parameter Measurement Information	11	11.4	Electrostatic Discharge Caution	18
7	Detailed Description	12	11.5	Glossary	18
7.1	Overview	12	12	机械、封装和可订购信息	18

4 Pin Configuration and Functions

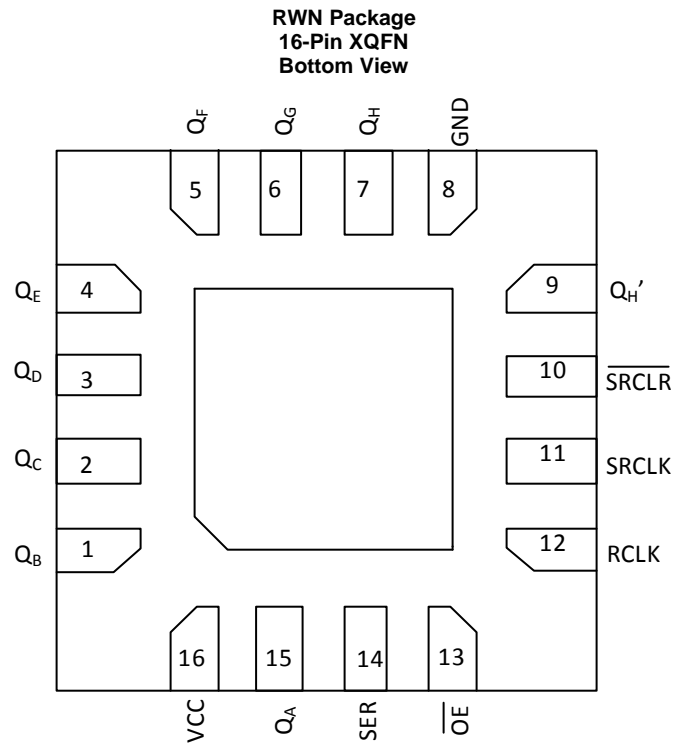
Table 2. Pin Functions

PIN		I/O	DESCRIPTION
NAME	RWN		
GND	8	—	Ground Pin
\overline{OE}	13	I	Output Enable; does not control $Q_{H'}$
Q_A	15	O	Q_A Output
Q_B	1	O	Q_B Output
Q_C	2	O	Q_C Output
Q_D	3	O	Q_D Output
Q_E	4	O	Q_E Output
Q_F	5	O	Q_F Output
Q_G	6	O	Q_G Output
Q_H	7	O	Q_H Output
$Q_{H'}$	9	O	$Q_{H'}$ Output
RCLK	12	I	RCLK Input
SER	14	I	SER Input
SRCLK	11	I	SRCLK Input
\overline{SRCLR}	10	I	\overline{SRCLR} Input
VCC	16	—	Power Pin

5 Specifications

5.1 Absolute Maximum Ratings

over operating free-air temperature range (unless otherwise noted)⁽¹⁾

		MIN	MAX	UNIT	
V _{CC}	Supply voltage	-0.5	7	V	
V _I	Input voltage	-0.5	7	V	
I _{IK}	Input clamp current ⁽¹⁾	V _I < 0	-20	mA	
I _{OK}	Output clamp current ⁽²⁾	V _O < 0 or V _O > V _{CC}	±20	mA	
I _O	Continuous output current	V _O = 0 to V _{CC}	±35	mA	
Continuous current through V _{CC} or GND			±70	mA	
T _J	Junction temperature		150	°C	
T _{stg}	Storage temperature		-65	150	°C

- (1) Stresses beyond those listed under *Absolute Maximum Ratings* may cause permanent damage to the device. These are stress ratings only, and functional operation of the device at these or any other conditions beyond those indicated under *Recommended Operating Conditions* is not implied. Exposure to absolute-maximum-rated conditions for extended periods may affect device reliability.
- (2) The input and output voltage ratings may be exceeded if the input and output current ratings are observed.

5.2 ESD Ratings

		VALUE	UNIT
V _(ESD)	Electrostatic discharge	Human body model (HBM), per ANSI/ESDA/JEDEC JS-001, all pins ⁽¹⁾	±2000
		Charged-device model (CDM), per JEDEC specification JESD22-C101, all pins ⁽²⁾	±1000

- (1) JEDEC document JEP155 states that 500-V HBM allows safe manufacturing with a standard ESD control process.
- (2) JEDEC document JEP157 states that 250-V CDM allows safe manufacturing with a standard ESD control process.

5.3 Recommended Operating Conditions

over operating free-air temperature range (unless otherwise noted)⁽¹⁾

		SN74HC595B			UNIT
		MIN	NOM	MAX	
V _{CC}	Supply voltage	2	5	6	V
V _{IH}	High-level input voltage	V _{CC} = 2 V	1.5		V
		V _{CC} = 4.5 V	3.15		
		V _{CC} = 6 V	4.2		
V _{IL}	Low-level input voltage	V _{CC} = 2 V		0.5	V
		V _{CC} = 4.5 V		1.35	
		V _{CC} = 6 V		1.8	
V _I	Input voltage	0		V _{CC}	V
V _O	Output voltage	0		V _{CC}	V
Δt/Δv	Input transition rise or fall time ⁽²⁾	V _{CC} = 2 V		1000	ns
		V _{CC} = 4.5 V		500	
		V _{CC} = 6 V		400	
T _A	Operating free-air temperature	-55		125	°C

- (1) All unused inputs of the device must be held at V_{CC} or GND to ensure proper device operation. See the TI application report, *Implications of Slow or Floating CMOS Inputs*, [SCBA004](#).
- (2) If this device is used in the threshold region (from V_{IL,max} = 0.5 V to V_{IH,min} = 1.5 V), there is a potential to go into the wrong state from induced grounding, causing double clocking. Operating with the inputs at t_i = 1000 ns and V_{CC} = 2 V does not damage the device; however, functionally, the CLK inputs are not ensured while in the shift, count, or toggle operating modes.

5.4 Thermal Information

THERMAL METRIC ⁽¹⁾		SN74HC595B	UNIT
		RWN (X1QFN)	
		16 PINS	
R _{θJA}	Junction-to-ambient thermal resistance	112	°C/W
R _{θJctop}	Junction-to-case (top) thermal resistance	47.9	
R _{θJB}	Junction-to-board thermal resistance	72.4	
ψ _{JT}	Junction-to-top characterization parameter	0.6	
ψ _{JB}	Junction-to-board characterization parameter	72.4	
R _{θJcbot}	Junction-to-case (bottom) thermal resistance	32.2	

(1) For more information about traditional and new thermal metrics, see the *Semiconductor and IC Package Thermal Metrics* application report, [SPRA953](#).

5.5 Electrical Characteristics

over recommended operating free-air temperature range (unless otherwise noted)

PARAMETER	TEST CONDITIONS		V _{CC}	T _A = 25°C			T _A = -55°C to 125°C		T _A = -40°C to 85°C		UNIT
				MIN	TYP	MAX	MIN	MAX	MIN	MAX	
V _{OH}	V _I = V _{IH} or V _{IL}	I _{OH} = -20 μA	2 V	1.9	1.998		1.9		1.9	V	
			4.5 V	4.4	4.499		4.4		4.4		
			6 V	5.9	5.999		5.9		5.9		
		4.5 V	Q _H , I _{OH} = -4 mA	3.98	4.3		3.7		3.84		
			Q _A - Q _H , I _{OH} = -6 mA	3.98	4.3		3.7		3.84		
			Q _H , I _{OH} = -5.2 mA	6 V	5.48	5.8		5.2			5.34
Q _A - Q _H , I _{OH} = -7.8 mA	5.48	5.8			5.2		5.34				
V _{OL}	V _I = V _{IH} or V _{IL}	I _{OL} = 20 μA	2 V		0.002	0.1		0.1		0.1	V
			4.5 V		0.001	0.1		0.1		0.1	
			6 V		0.001	0.1		0.1		0.1	
		4.5 V	Q _H , I _{OL} = 4 mA		0.17	0.26		0.4		0.33	
			Q _A - Q _H , I _{OL} = 6 mA		0.17	0.26		0.4		0.33	
			Q _H , I _{OL} = 5.2 mA	6 V	0.15	0.26		0.4		0.33	
Q _A - Q _H , I _{OL} = 7.8 mA	0.15	0.26			0.4		0.33				
I _I	V _I = V _{CC} or 0	6 V		±0.1	±100		±1000		±1000	nA	
I _{OZ}	V _O = V _{CC} or 0, Q _A - Q _H	6 V		±0.01	±0.5		±10		±5	μA	
I _{CC}	V _I = V _{CC} or 0, I _O = 0	6 V			8		160		80	μA	
C _i		2 V to 6 V		3	10		10		10	pF	

5.6 Timing Requirements

over operating free-air temperature range (unless otherwise noted)

		V _{CC}	T _A = 25°C		T _A = -55°C to 125°C		T _A = -40°C to 85°C		UNIT
			MIN	MAX	MIN	MAX	MIN	MAX	
f _{clock}	Clock frequency	2 V	6		4.2		5		MHz
		4.5 V	31		21		25		
		6 V	36		25		29		
t _w	SRCLK or RCLK high or low	2 V	80	120		100		ns	
		4.5 V	16	24		20			
		6 V	14	20		17			
	SRCLR low	2 V	80	120		100			
		4.5 V	16	24		20			
		6 V	14	20		17			
t _{su}	SER before SRCLK↑	2 V	100	150		125		ns	
		4.5 V	20	30		25			
		6 V	17	25		21			
	SRCLK↑ before RCLK↑ ⁽¹⁾	2 V	75	113		94			
		4.5 V	15	23		19			
		6 V	13	19		16			
	SRCLR low before RCLK↑	2 V	50	75		65			
		4.5 V	10	15		13			
		6 V	9	13		11			
	SRCLR high (inactive) before SRCLK↑	2 V	50	75		60			
		4.5 V	10	15		12			
		6 V	9	13		11			
t _h	Hold time, SER after SRCLK↑	2 V	0	0		0		ns	
		4.5 V	0	0		0			
		6 V	0	0		0			

(1) This set-up time allows the storage register to receive stable data from the shift register. The clocks can be tied together, in which case the shift register is one clock pulse ahead of the storage register.

5.7 Switching Characteristics

Over recommended operating free-air temperature range.

PARAMETER	FROM (INPUT)	TO (OUTPUT)	LOAD CAPACITANCE	V _{CC}	T _A = 25°C			T _A = -55°C to 125°C		T _A = -40°C to 85°C		UNIT
					MIN	TYP	MAX	MIN	MAX	MIN	MAX	
f _{max}			50 pF	2 V	6	26		4.2		5	MHz	
				4.5 V	31	38		21		25		
				6 V	36	42		25		29		
t _{pd}	SRCLK	Q _{H'}	50 pF	2 V		50	160		240		200	ns
				4.5 V		17	32		48		40	
				6 V		14	27		41		34	
	RCLK	Q _A – Q _H	50 pF	2 V		50	150		225		187	
				4.5 V		17	30		45		37	
				6 V		14	26		38		32	
t _{PHL}	$\overline{\text{SRCLR}}$	Q _{H'}	50 pF	2 V		51	175		261		219	ns
				4.5 V		18	35		52		44	
				6 V		15	30		44		37	
t _{en}	$\overline{\text{OE}}$	Q _A – Q _H	50 pF	2 V		40	150		255		187	ns
				4.5 V		15	30		45		37	
				6 V		13	26		38		32	
t _{dis}	$\overline{\text{OE}}$	Q _A – Q _H	50 pF	2 V		42	200		300		250	ns
				4.5 V		23	40		60		50	
				6 V		20	34		51		43	
t _t		Q _A – Q _H	50 pF	2 V		28	60		90		75	ns
				4.5 V		8	12		18		15	
				6 V		6	10		15		13	
		Q _{H'}	50 pF	2 V		28	75		110		95	
				4.5 V		8	15		22		19	
				6 V		6	13		19		16	
t _{pd}	RCLK	Q _A – Q _H	150 pf	2 V		60	200		300		250	ns
				4.5 V		22	40		60		50	
				6 V		19	34		51		43	
t _{en}	$\overline{\text{OE}}$	Q _A – Q _H	150 pf	2 V		70	200		298		250	ns
				4.5 V		23	40		60		50	
				6 V		19	34		51		43	
t _t		Q _A – Q _H	150 pf	2 V		45	210		315		265	ns
				4.5 V		17	42		63		53	
				6 V		13	36		53		45	

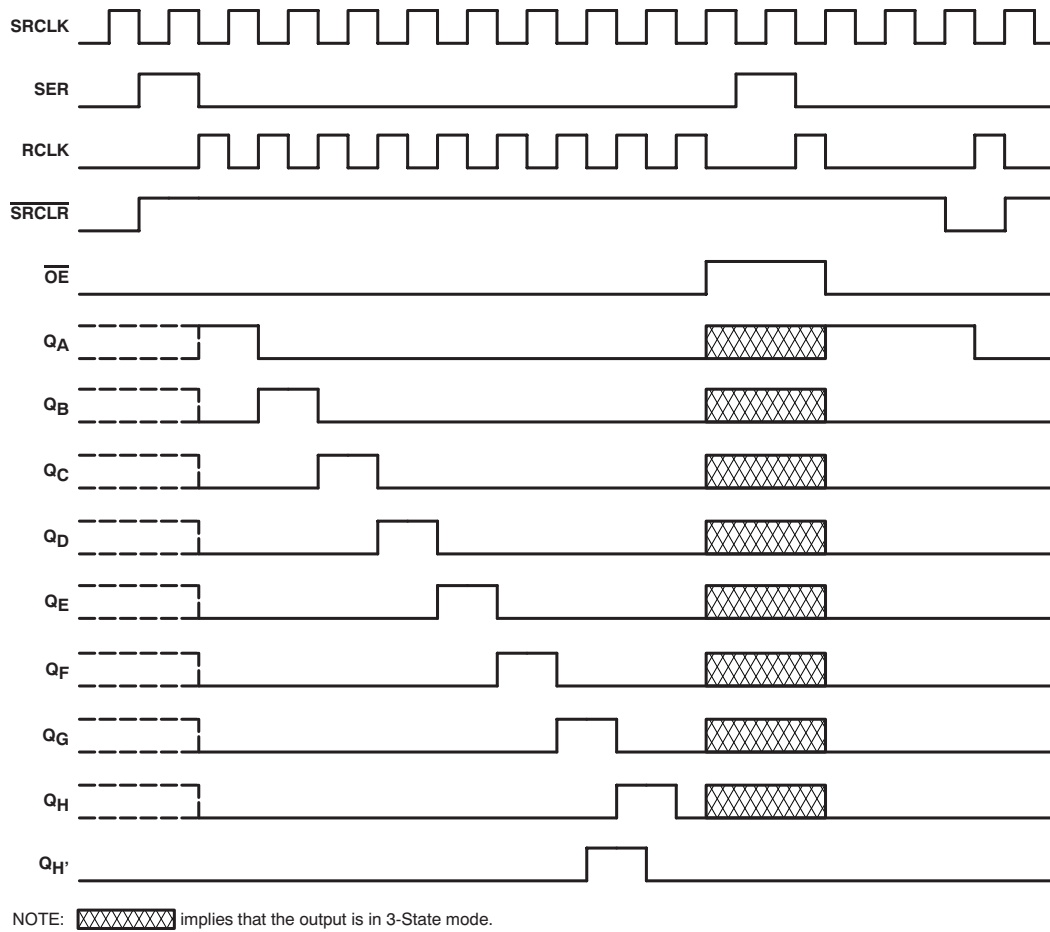

Figure 2. Timing Diagram

5.8 Operating Characteristics

T_A = 25°C

PARAMETER		TEST CONDITIONS	TYP	UNIT
C _{pd}	Power dissipation capacitance	No load	400	pF

5.9 Typical Characteristics

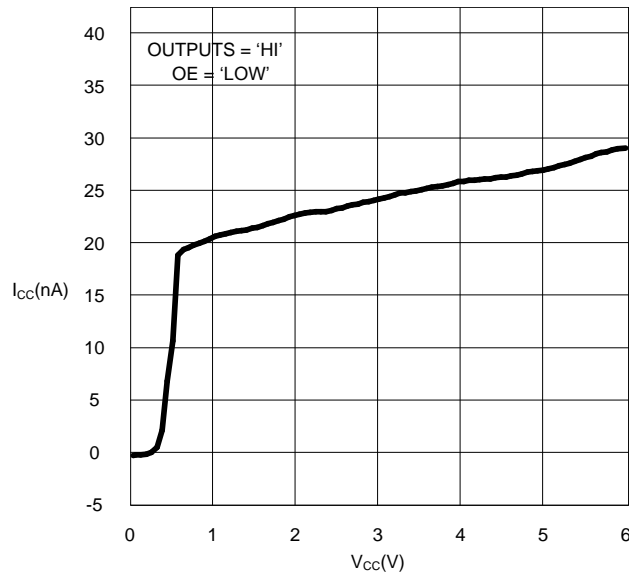
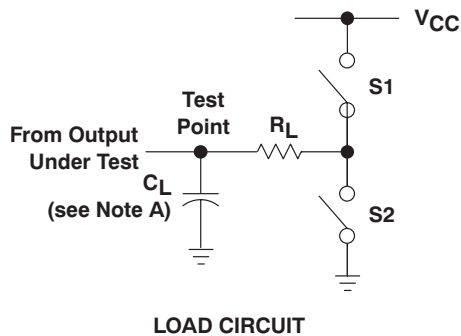
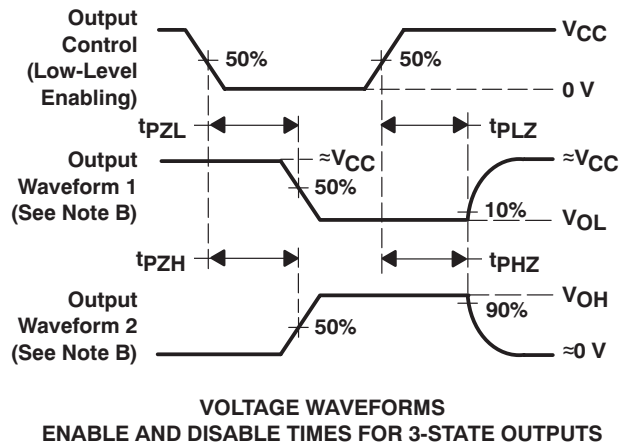
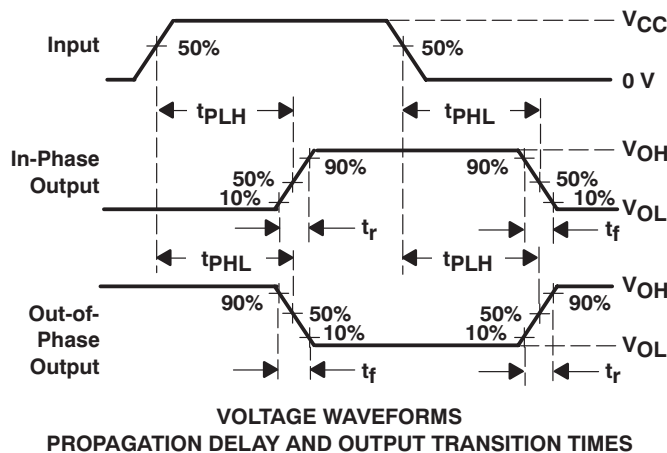
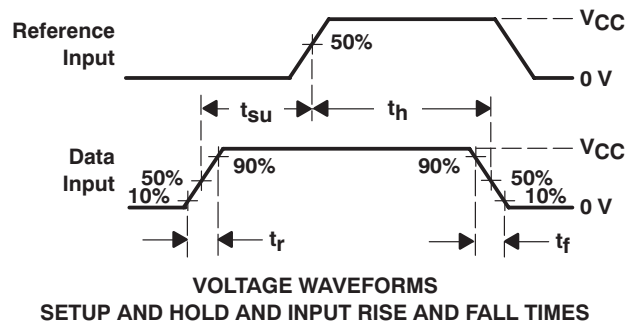
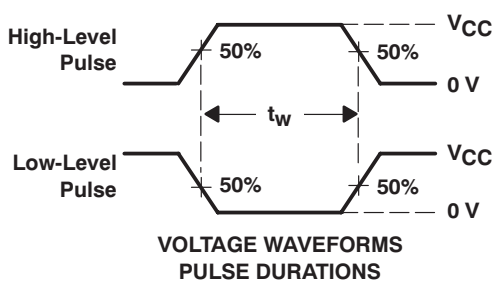

Figure 3. SN74HC595B I_{CC} vs. V_{CC}

6 Parameter Measurement Information



PARAMETER	R_L	C_L	S1	S2
t_{en}	1 k Ω	50 pF or 150 pF	Open	Closed
			Closed	Open
t_{dis}	1 k Ω	50 pF	Open	Closed
			Closed	Open
t_{pd} or t_t		50 pF or 150 pF	Open	Open



- NOTES:
- A. C_L includes probe and test-fixture capacitance.
 - B. Waveform 1 is for an output with internal conditions such that the output is low, except when disabled by the output control. Waveform 2 is for an output with internal conditions such that the output is high, except when disabled by the output control.
 - C. Phase relationships between waveforms were chosen arbitrarily. All input pulses are supplied by generators having the following characteristics: $PRR \leq 1$ MHz, $Z_O = 50 \Omega$, $t_r = 6$ ns, $t_f = 6$ ns.
 - D. For clock inputs, f_{max} is measured when the input duty cycle is 50%.
 - E. The outputs are measured one at a time, with one input transition per measurement.
 - F. t_{PLZ} and t_{PHZ} are the same as t_{dis} .
 - G. t_{PZL} and t_{PZH} are the same as t_{en} .
 - H. t_{PLH} and t_{PHL} are the same as t_{pd} .

Figure 4. Load Circuit and Voltage Waveforms

7 Detailed Description

7.1 Overview

The SN74HC595B is part of the HC family of logic devices intended for CMOS applications. The SN74HC595B device is an 8-bit shift register that feeds an 8-bit D-type storage register.

Both the shift register clock (SRCLK) and storage register clock (RCLK) are positive-edge triggered. If both clocks are connected together, the shift register is always one clock pulse ahead of the storage register. The Q_H may be used for daisy chaining the device and will not go into high impedance when \overline{OE} is asserted.

7.2 Functional Block Diagram

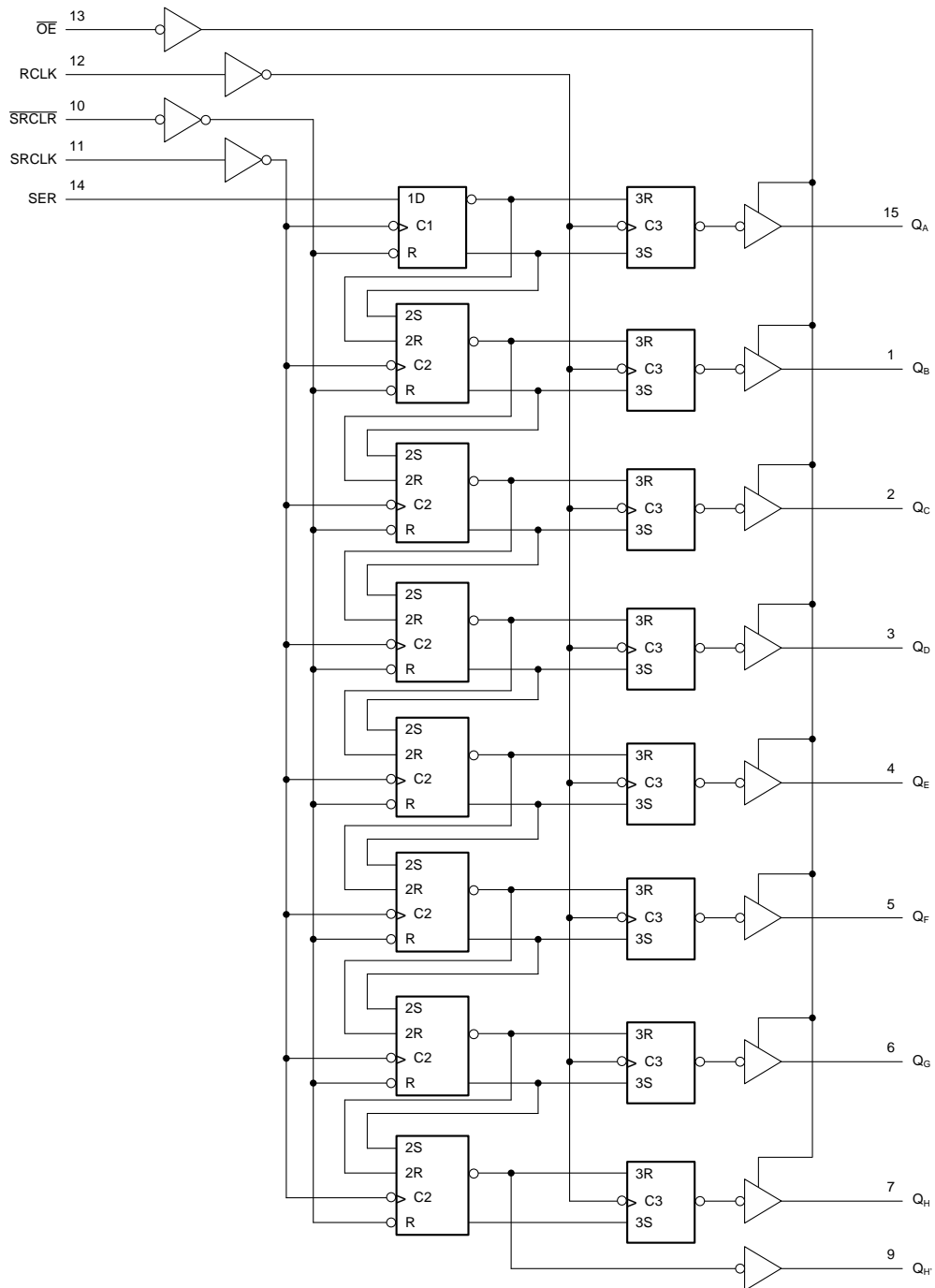

Figure 5. Logic Diagram (Positive Logic)

7.3 Feature Description

The SN74HC595B device is an 8-bit Serial-In, Parallel-Out shift register. It has a wide operating voltage of 2 V to 6 V, and the high-current 3-state outputs can drive up to 15 LSTTL Loads. The device has a low power consumption of 80- μ A (Maximum) I_{CC} . Additionally, this device has a low input current of 1 μ A (Maximum) and a ± 6 -mA output drive at 5 V. The device is available currently in the smallest logic QFN package at 0.5 mm max height with 0.4 mm pitch. The inputs are over voltage tolerant independent of V_{CC} .

7.4 Device Functional Modes

Table 3 lists the functional modes of the SN74HC595B devices.

Table 3. Function Table

INPUTS					FUNCTION
SER	SRCLK	SRCLR	RCLK	\overline{OE}	
–	–	–	–	H	Outputs $Q_A - Q_H$ are disabled. Q_H is active .
–	–	–	–	L	Outputs $Q_A - Q_H$ are enabled.
–	–	L	–	–	Shift register is cleared.
L	↑	H	–	–	First stage of the shift register goes low. Other stages store the data of previous stage, respectively.
H	↑	H	–	–	First stage of the shift register goes high. Other stages store the data of previous stage, respectively.
–	–	–	↑	–	Shift-register data is stored in the storage register.

8 Application and Implementation

8.1 Application Information

The SN74HC595B is a low-drive CMOS device that is used for a multitude of bus interface type applications where output ringing is a concern. The low drive and slow edge rates will minimize overshoot and undershoot on the outputs. Q_H pin of the first register should be connected to the serial (SER) pin of the second register for daisy chaining.

8.2 Typical Application

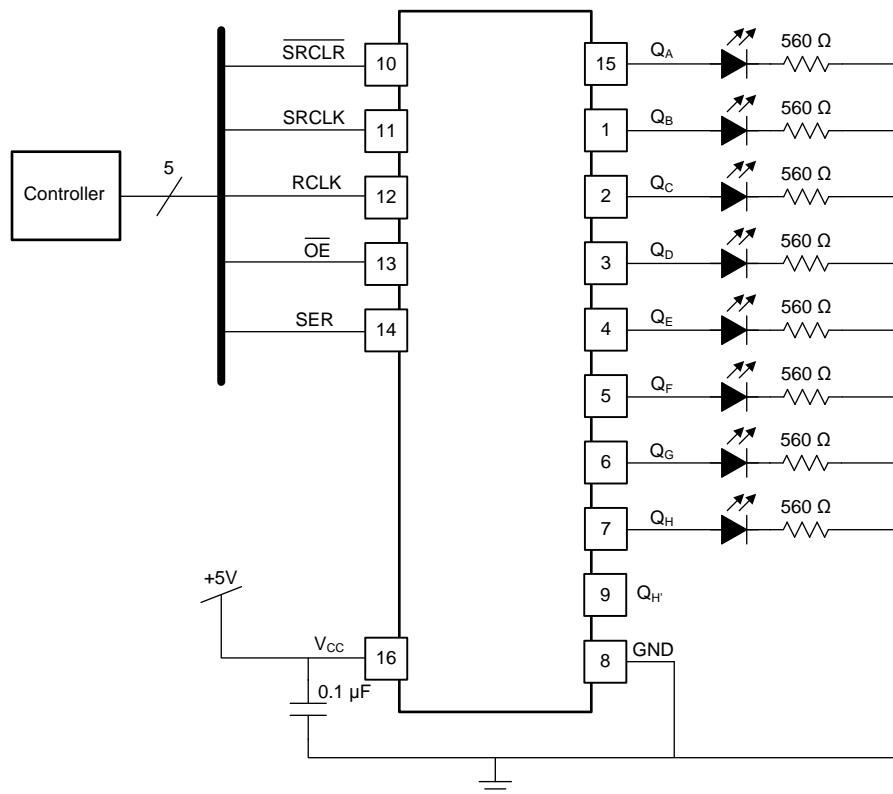

Figure 6. Typical Application Schematic

8.2.1 Design Requirements

This device uses CMOS technology and has a balanced output drive. Take care to avoid bus contention because it can drive currents in excess of the maximum limits. The high drive will also create fast edges into light loads, so routing and load conditions should be considered to prevent ringing.

8.2.2 Detailed Design Procedure

- Recommended input conditions
 - Specified high and low levels. See (V_{IH} and V_{IL}) in the [Recommended Operating Conditions](#) table.
 - Specified high and low levels. See (V_{IH} and V_{IL}) in the [Recommended Operating Conditions](#) table.
 - Inputs are over-voltage tolerant allowing them to go as high as 5.5 V at any valid V_{CC}
- Recommended output conditions
 - Load currents should not exceed 35 mA per output as per the [Absolute Maximum Ratings](#) table.
 - Outputs should not be pulled below Ground or above V_{CC}

Typical Application (continued)

8.2.3 Application Curves

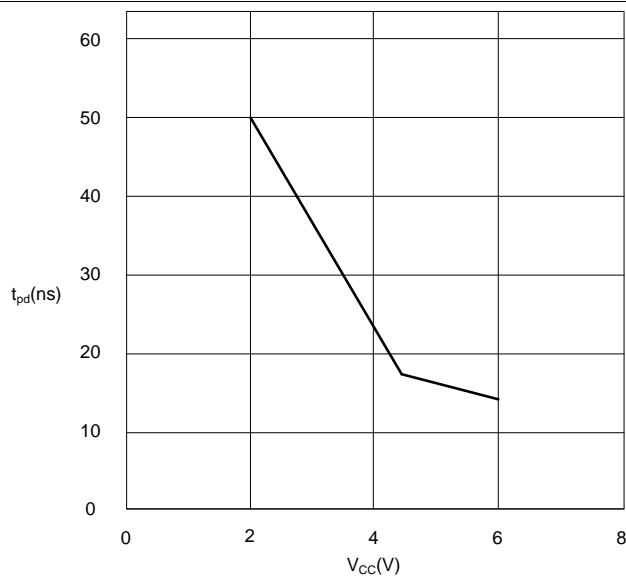

Figure 7. SN75HC595B t_{pd} vs. V_{CC}

9 Power Supply Recommendations

The power supply can be any voltage between the minimum and maximum supply voltage rating located in the [Recommended Operating Conditions](#) table. The total current through Ground or V_{CC} should not exceed 70 mA as per [Absolute Maximum Ratings](#) table.

Each V_{CC} pin should have a good bypass capacitor to prevent power disturbance. For devices with a single supply, 0.1 µf is recommended; if there are multiple V_{CC} pins, then 0.01 µf or 0.022 µf is recommended for each power pin. It is acceptable to parallel multiple bypass caps to reject different frequencies of noise. A 0.1 µf and a 1 µf are commonly used in parallel. The bypass capacitor should be installed as close to the power pin as possible for best results.

10 Layout

10.1 Layout Guidelines

When using multiple-bit logic devices, inputs should never float.

In many cases, functions or parts of functions of digital logic devices are unused, for example, when only two inputs of a triple-input and the gate are used, or only 3 of the 4 buffer gates are used. Such input pins should not be left unconnected because the undefined voltages at the outside connections result in undefined operational states. [Figure 8](#) specifies the rules that must be observed under all circumstances. All unused inputs of digital logic devices must be connected to a high or low bias to prevent them from floating. The logic level that should be applied to any particular unused input depends on the function of the device. Generally, they will be tied to GND or V_{CC}, whichever makes more sense or is more convenient. It is acceptable to float outputs, unless the part is a transceiver. If the transceiver has an output enable pin, it will disable the output section of the part when asserted. This will not disable the input section of the I/Os, so they cannot float when disabled.

10.2 Layout Example

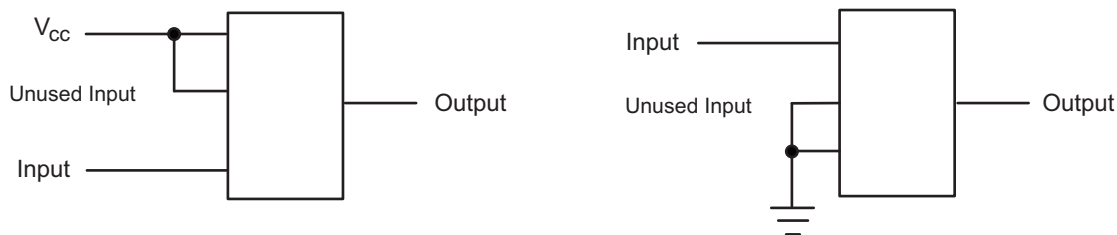

Figure 8. Layout Diagram

11 器件和文档支持

11.1 文档支持

11.1.1 相关文档

相关文档如下：

《CMOS 输入缓慢变化或悬空的影响》，[SCBA004](#)

11.2 社区资源

The following links connect to TI community resources. Linked contents are provided "AS IS" by the respective contributors. They do not constitute TI specifications and do not necessarily reflect TI's views; see TI's [Terms of Use](#).

TI E2E™ Online Community *TI's Engineer-to-Engineer (E2E) Community*. Created to foster collaboration among engineers. At e2e.ti.com, you can ask questions, share knowledge, explore ideas and help solve problems with fellow engineers.

Design Support *TI's Design Support* Quickly find helpful E2E forums along with design support tools and contact information for technical support.

11.3 Trademarks

E2E is a trademark of Texas Instruments.
All other trademarks are the property of their respective owners.

11.4 Electrostatic Discharge Caution



These devices have limited built-in ESD protection. The leads should be shorted together or the device placed in conductive foam during storage or handling to prevent electrostatic damage to the MOS gates.

11.5 Glossary

[SLYZ022](#) — *TI Glossary*.

This glossary lists and explains terms, acronyms, and definitions.

12 机械、封装和可订购信息

以下页中包括机械封装和可订购信息。这些信息是针对指定器件可提供的最新数据。这些数据会在无通知且不对本文档进行修订的情况下发生改变。要获得这份数据表的浏览器版本，请查阅左侧导航栏。

重要声明

德州仪器(TI)及其下属子公司有权根据 JESD46 最新标准,对所提供的产品和服务进行更正、修改、增强、改进或其它更改,并有权根据 JESD48 最新标准中止提供任何产品和服务。客户在下订单前应获取最新的相关信息,并验证这些信息是否完整且是最新的。所有产品的销售都遵循在订单确认时所提供的TI 销售条款与条件。

TI 保证其所销售的组件的性能符合产品销售时 TI 半导体产品销售条件与条款的适用规范。仅在 TI 保证的范围内,且 TI 认为有必要时才会使用测试或其它质量控制技术。除非适用法律做出了硬性规定,否则没有必要对每种组件的所有参数进行测试。

TI 对应用帮助或客户产品设计不承担任何义务。客户应对其使用 TI 组件的产品和应用自行负责。为尽量减小与客户产品和应用相关的风险,客户应提供充分的设计与操作安全措施。

TI 不对任何 TI 专利权、版权、屏蔽作品权或其它与使用了 TI 组件或服务的组合设备、机器或流程相关的 TI 知识产权中授予的直接或隐含权限作出任何保证或解释。TI 所发布的与第三方产品或服务有关的信息,不能构成从 TI 获得使用这些产品或服务的许可、授权、或认可。使用此类信息可能需要获得第三方的专利权或其它知识产权方面的许可,或是 TI 的专利权或其它知识产权方面的许可。

对于 TI 的产品手册或数据表中 TI 信息的重要部分,仅在没有对内容进行任何篡改且带有相关授权、条件、限制和声明的情况下才允许进行复制。TI 对此类篡改过的文件不承担任何责任或义务。复制第三方的信息可能需要服从额外的限制条件。

在转售 TI 组件或服务时,如果对该组件或服务参数的陈述与 TI 标明的参数相比存在差异或虚假成分,则会失去相关 TI 组件或服务的所有明示或暗示授权,且这是不正当的、欺诈性商业行为。TI 对任何此类虚假陈述均不承担任何责任或义务。

客户认可并同意,尽管任何应用相关信息或支持仍可能由 TI 提供,但他们将独立负责满足与其产品及其在应用中使用的 TI 产品相关的所有法律、法规和安全相关要求。客户声明并同意,他们具备制定与实施安全措施所需的全部专业技术和知识,可预见故障的危险后果、监测故障及其后果、降低有可能造成人身伤害的故障的发生机率并采取适当的补救措施。客户将全额赔偿因在此类安全关键应用中使用任何 TI 组件而对 TI 及其代理造成的任何损失。

在某些场合中,为了推进安全相关应用有可能对 TI 组件进行特别的促销。TI 的目标是利用此类组件帮助客户设计和创立其特有的可满足适用的功能安全性标准和要求的终端产品解决方案。尽管如此,此类组件仍然服从这些条款。

TI 组件未获得用于 FDA Class III (或类似的生命攸关医疗设备)的授权许可,除非各方授权官员已经达成了专门管控此类使用的特别协议。

只有那些 TI 特别注明属于军用等级或“增强型塑料”的 TI 组件才是设计或专门用于军事/航空应用或环境的。购买者认可并同意,对并非指定面向军事或航空航天用途的 TI 组件进行军事或航空航天方面的应用,其风险由客户单独承担,并且由客户独立负责满足与此类使用相关的所有法律和法规要求。

TI 已明确指定符合 ISO/TS16949 要求的产品,这些产品主要用于汽车。在任何情况下,因使用非指定产品而无法达到 ISO/TS16949 要求, TI 不承担任何责任。

	产品		应用
数字音频	www.ti.com.cn/audio	通信与电信	www.ti.com.cn/telecom
放大器和线性器件	www.ti.com.cn/amplifiers	计算机及周边	www.ti.com.cn/computer
数据转换器	www.ti.com.cn/dataconverters	消费电子	www.ti.com.cn/consumer-apps
DLP® 产品	www.dlp.com	能源	www.ti.com.cn/energy
DSP - 数字信号处理器	www.ti.com.cn/dsp	工业应用	www.ti.com.cn/industrial
时钟和计时器	www.ti.com.cn/clockandtimers	医疗电子	www.ti.com.cn/medical
接口	www.ti.com.cn/interface	安防应用	www.ti.com.cn/security
逻辑	www.ti.com.cn/logic	汽车电子	www.ti.com.cn/automotive
电源管理	www.ti.com.cn/power	视频和影像	www.ti.com.cn/video
微控制器 (MCU)	www.ti.com.cn/microcontrollers		
RFID 系统	www.ti.com.cn/rfidsys		
OMAP应用处理器	www.ti.com/omap		
无线连通性	www.ti.com.cn/wirelessconnectivity	德州仪器在线技术支持社区	www.deyisupport.com

邮寄地址: 上海市浦东新区世纪大道1568号, 中建大厦32楼邮政编码: 200122
Copyright © 2016, 德州仪器半导体技术(上海)有限公司

PACKAGING INFORMATION

Orderable Device	Status (1)	Package Type	Package Drawing	Pins	Package Qty	Eco Plan (2)	Lead finish/ Ball material (6)	MSL Peak Temp (3)	Op Temp (°C)	Device Marking (4/5)	Samples
SN74HC595BRWNR	ACTIVE	X1QFN	RWN	16	2000	RoHS & Green	NIPDAU	Level-1-260C-UNLIM	-55 to 125	13YI	Samples

(1) The marketing status values are defined as follows:

ACTIVE: Product device recommended for new designs.

LIFEBUY: TI has announced that the device will be discontinued, and a lifetime-buy period is in effect.

NRND: Not recommended for new designs. Device is in production to support existing customers, but TI does not recommend using this part in a new design.

PREVIEW: Device has been announced but is not in production. Samples may or may not be available.

OBSOLETE: TI has discontinued the production of the device.

(2) **RoHS:** TI defines "RoHS" to mean semiconductor products that are compliant with the current EU RoHS requirements for all 10 RoHS substances, including the requirement that RoHS substance do not exceed 0.1% by weight in homogeneous materials. Where designed to be soldered at high temperatures, "RoHS" products are suitable for use in specified lead-free processes. TI may reference these types of products as "Pb-Free".

RoHS Exempt: TI defines "RoHS Exempt" to mean products that contain lead but are compliant with EU RoHS pursuant to a specific EU RoHS exemption.

Green: TI defines "Green" to mean the content of Chlorine (Cl) and Bromine (Br) based flame retardants meet JS709B low halogen requirements of <=1000ppm threshold. Antimony trioxide based flame retardants must also meet the <=1000ppm threshold requirement.

(3) MSL, Peak Temp. - The Moisture Sensitivity Level rating according to the JEDEC industry standard classifications, and peak solder temperature.

(4) There may be additional marking, which relates to the logo, the lot trace code information, or the environmental category on the device.

(5) Multiple Device Markings will be inside parentheses. Only one Device Marking contained in parentheses and separated by a "-" will appear on a device. If a line is indented then it is a continuation of the previous line and the two combined represent the entire Device Marking for that device.

(6) Lead finish/Ball material - Orderable Devices may have multiple material finish options. Finish options are separated by a vertical ruled line. Lead finish/Ball material values may wrap to two lines if the finish value exceeds the maximum column width.

Important Information and Disclaimer:The information provided on this page represents TI's knowledge and belief as of the date that it is provided. TI bases its knowledge and belief on information provided by third parties, and makes no representation or warranty as to the accuracy of such information. Efforts are underway to better integrate information from third parties. TI has taken and continues to take reasonable steps to provide representative and accurate information but may not have conducted destructive testing or chemical analysis on incoming materials and chemicals. TI and TI suppliers consider certain information to be proprietary, and thus CAS numbers and other limited information may not be available for release.

In no event shall TI's liability arising out of such information exceed the total purchase price of the TI part(s) at issue in this document sold by TI to Customer on an annual basis.

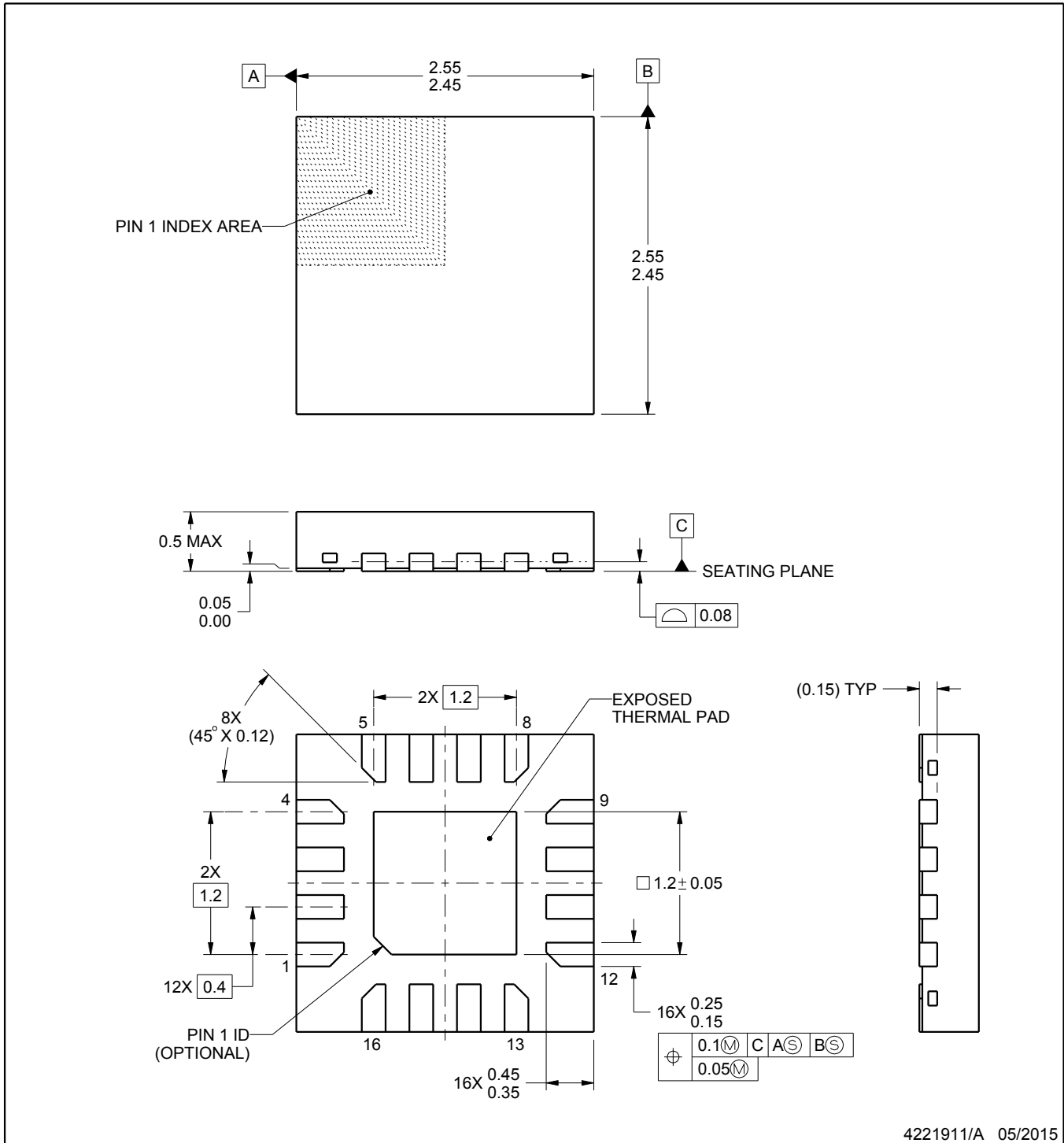
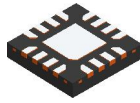

4221911/A 05/2015

NOTES:

1. All linear dimensions are in millimeters. Any dimensions in parenthesis are for reference only. Dimensioning and tolerancing per ASME Y14.5M.
2. This drawing is subject to change without notice.
3. The package thermal pad must be soldered to the printed circuit board for thermal and mechanical performance.

EXAMPLE BOARD LAYOUT

RWN0016A

X1QFN - 0.5 mm max height

PLASTIC QUAD FLATPACK - NO LEAD

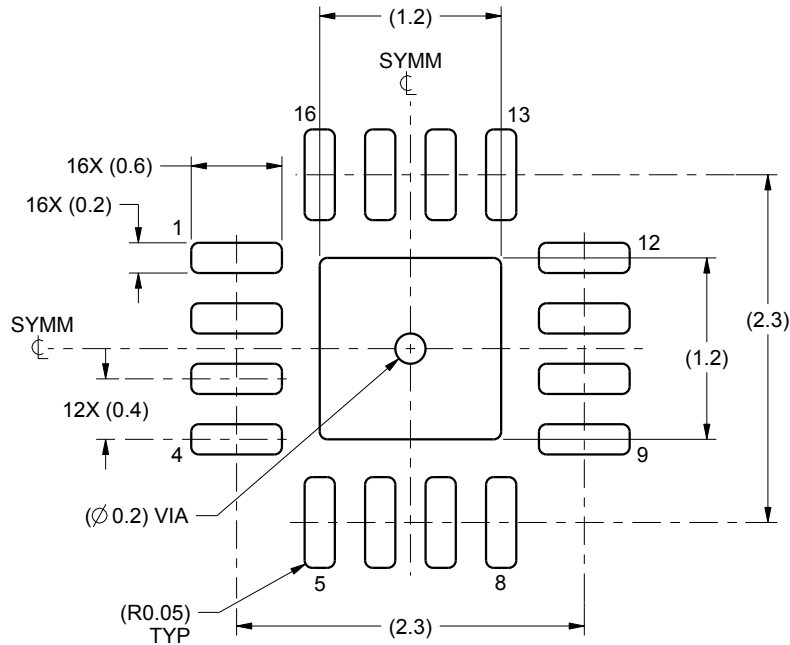

LAND PATTERN EXAMPLE
SCALE:20X

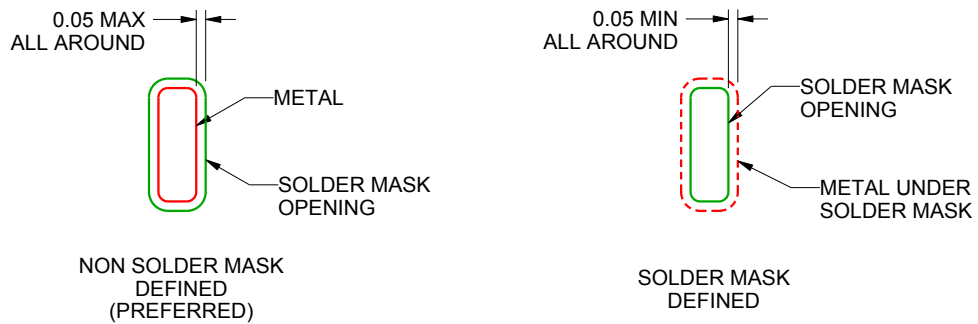

SOLDER MASK DETAILS

4221911/A 05/2015

NOTES: (continued)

4. This package is designed to be soldered to a thermal pad on the board. For more information, see Texas Instruments literature number SLUA271 (www.ti.com/lit/slue271).

EXAMPLE STENCIL DESIGN

RWN0016A

X1QFN - 0.5 mm max height

PLASTIC QUAD FLATPACK - NO LEAD

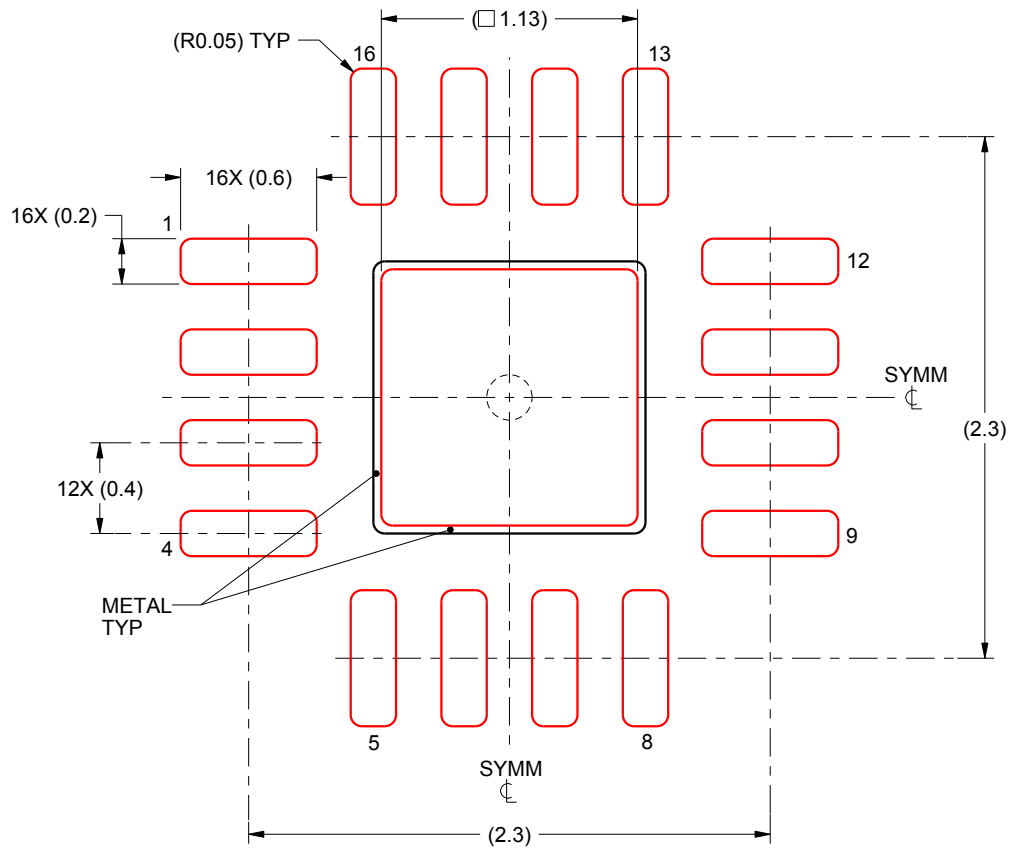

SOLDER PASTE EXAMPLE
BASED ON 0.1 mm THICK STENCIL

EXPOSED PAD
88% PRINTED SOLDER COVERAGE BY AREA
SCALE:30X

4221911/A 05/2015

NOTES: (continued)

5. Laser cutting apertures with trapezoidal walls and rounded corners may offer better paste release. IPC-7525 may have alternate design recommendations.

重要声明和免责声明

TI 均以“原样”提供技术性及其可靠性数据（包括数据表）、设计资源（包括参考设计）、应用或其他设计建议、网络工具、安全信息和其他资源，不保证其中不含任何瑕疵，且不做任何明示或暗示的担保，包括但不限于对适销性、适合某特定用途或不侵犯任何第三方知识产权的暗示担保。

所述资源可供专业开发人员应用TI 产品进行设计使用。您将对以下行为独自承担全部责任：(1) 针对您的应用选择合适的TI 产品；(2) 设计、验证并测试您的应用；(3) 确保您的应用满足相应标准以及任何其他安全、安保或其他要求。所述资源如有变更，恕不另行通知。TI 对您使用所述资源的授权仅限于开发资源所涉及TI 产品的相关应用。除此之外不得复制或展示所述资源，也不提供其它TI 或任何第三方的知识产权授权许可。如因使用所述资源而产生任何索赔、赔偿、成本、损失及债务等，TI 对此概不负责，并且您须赔偿由此对TI 及其代表造成的损害。

TI 所提供产品均受TI 的销售条款 (<http://www.ti.com.cn/zh-cn/legal/termsofsale.html>) 以及 [ti.com.cn](http://www.ti.com.cn) 上或随附TI 产品提供的其他可适用条款的约束。TI 提供所述资源并不扩展或以其他方式更改TI 针对TI 产品所发布的可适用的担保范围或担保免责声明。

邮寄地址：上海市浦东新区世纪大道 1568 号中建大厦 32 楼，邮政编码：200122

Copyright © 2020 德州仪器半导体技术（上海）有限公司