

MUX50x

36V 低电容、低电荷注入、精密模拟多路复用器

1 特性

- 低导通电容
 - MUX508: 9.4pF
 - MUX509: 6.7pF
- 低输入泄漏电流: 10pA
- 低电荷注入: 0.3pC
- 轨到轨运行
- 宽电源电压范围: $\pm 5V$ 至 $\pm 18V$ 或 $10V$ 至 $36V$
- 低导通电阻: 125 Ω
- 转换时间: 92ns
- 先断后合开关操作
- EN 引脚与 V_{DD} 相连
- 逻辑电平: $2V$ 至 V_{DD}
- 低电源电流: 45 μA
- 人体放电模式 (HBM) 静电放电 (ESD) 保护 > 2000V
- 行业标准的薄型小外形尺寸 (TSSOP) 封装和小外形尺寸集成电路 (SOIC) 封装

2 应用

- 工厂自动化和工业过程控制
- 可编程逻辑控制器 (PLC)
- 模拟输入模块
- 自动测试设备 (ATE)
- 数字万用表
- 电池监控系统

简化电路原理图

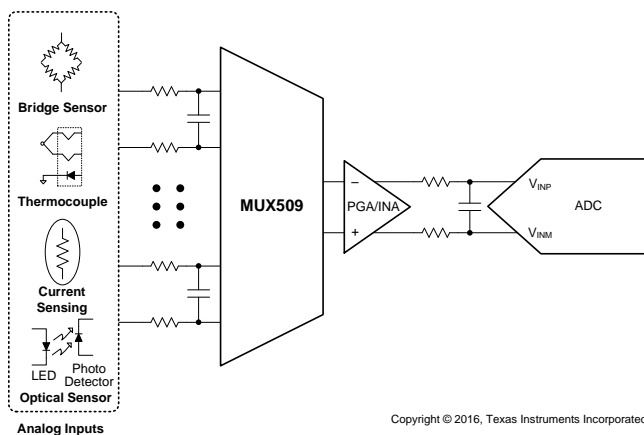

3 说明

MUX508 和 MUX509 (MUX50x) 是现代互补金属氧化物半导体 (CMOS) 模拟多路复用器 (mux)。MUX508 提供 8:1 单端通道, 而 MUX509 提供 4:1 差分通道或双 4:1 单端通道。MUX508 和 MUX509 在双电源 ($\pm 5V$ 至 $\pm 18V$) 或单电源 ($10V$ 至 $36V$) 供电时均能正常运行。两种器件在由对称电源 (如 $V_{DD} = 12V$, $V_{SS} = -12V$) 和非对称电源 (如 $V_{DD} = 12V$, $V_{SS} = -5V$) 供电时也能保证优异性能。所有数字输入具有兼容晶体管-晶体管逻辑电路 (TTL) 的阈值。当器件在有效电源电压范围内运行时, 该阈值可确保 TTL 和 CMOS 逻辑电路的兼容性。

MUX508 和 MUX509 这两款多路复用器的导通和关断泄漏电流都非常低, 因此能够以最小误差切换高输入阻抗源信号。该器件的电源电流低至 45 μA , 因此适用于便携式进行 VTT 放电。

器件信息⁽¹⁾

器件型号	封装	封装尺寸 (标称值)
MUX50x	TSSOP (16)	5.00mm x 4.40mm
	SOIC (16)	9.90mm x 3.91mm

(1) 要了解所有可用封装, 请参见数据表末尾的封装选项附录。

电荷注入与源电压间的关系

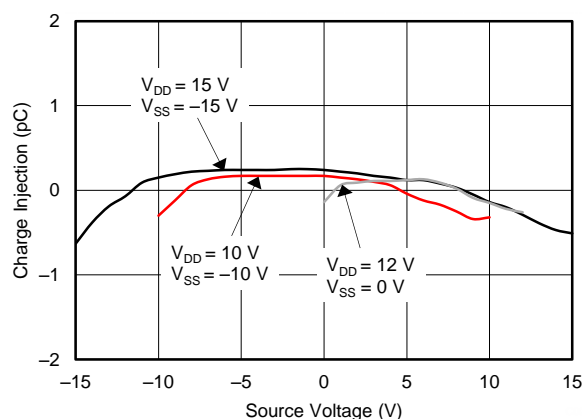

目录

1	特性	1	8.10	Channel-to-Channel Crosstalk	21
2	应用	1	8.11	Bandwidth	22
3	说明	1	8.12	THD + Noise	22
4	修订历史记录	2	9	Detailed Description	23
5	Device Comparison Table	4	9.1	Overview	23
6	Pin Configuration and Functions	4	9.2	Functional Block Diagram	23
7	Specifications	6	9.3	Feature Description	24
7.1	Absolute Maximum Ratings	6	9.4	Device Functional Modes	26
7.2	ESD Ratings	6	10	Applications and Implementation	27
7.3	Recommended Operating Conditions	6	10.1	Application Information	27
7.4	Thermal Information	7	10.2	Typical Application	27
7.5	Electrical Characteristics: Dual Supply	7	11	Power-Supply Recommendations	29
7.6	Electrical Characteristics: Single Supply	9	12	Layout	30
7.7	Typical Characteristics	11	12.1	Layout Guidelines	30
8	Parameter Measurement Information	15	12.2	Layout Example	30
8.1	Truth Tables	15	13	器件和文档支持	31
8.2	On-Resistance	16	13.1	文档支持	31
8.3	Off-Leakage Current	16	13.2	相关链接	31
8.4	On-Leakage Current	17	13.3	接收文档更新通知	31
8.5	Transition Time	17	13.4	社区资源	31
8.6	Break-Before-Make Delay	18	13.5	商标	31
8.7	Turn-On and Turn-Off Time	19	13.6	静电放电警告	31
8.8	Charge Injection	20	13.7	Glossary	31
8.9	Off Isolation	21	14	机械、封装和可订购信息	31

4 修订历史记录

注：之前版本的页码可能与当前版本有所不同。

Changes from Revision B (July 2016) to Revision C	Page
• 已将 D (SOIC) 封装添加至文档	1
• 已更改最后的 特性 分项以包括 SOIC 封装	1
• 已更改“描述”部分的第 部分	1
• 已将 SOIC 封装添加至 器件信息表	1
• Changed MUX509 description in <i>Device Comparison Table</i>	4
• Added D package to <i>Pin Configuration and Functions</i> section	4
• Added D package to <i>Thermal Information</i> table	7
• Changed Analog Switch, I_D parameter in <i>Electrical Characteristics: Dual Supply</i> table: split parameter into $I_{D(OFF)}$ and $I_{D(ON)}$ parameters, changed symbols, parameter names, and test conditions	7
• Changed <i>On-resistance drift</i> parameter in <i>Electrical Characteristics: Single Supply</i> table: changed V_S value in test conditions	9
• Changed Analog Switch, I_D parameter in <i>Electrical Characteristics: Single Supply</i> table: split parameter into $I_{D(OFF)}$ and $I_{D(ON)}$ parameters, changed symbols, parameter names, and $I_{D(ON)}$ test conditions	9
• Changed Figure 26 : changed switch symbol to a closed switch symbol	16
• Changed Figure 32 : added 0 V line, flipped V_S supply symbol	20
• Changed description of MUX509 in <i>Overview</i> section	23
• Changed Figure 42 : changed OPA140 amplifier and charge kickback filter box	27
• Added D package description to <i>Layout Guidelines</i> section	30

Changes from Revision A (March 2016) to Revision B **Page**

- 已增加 TI 设计 1
 - Changed Analog Switch, $I_{S(OFF)}$ and I_D parameter specifications in *Electrical Characteristics: Single Supply* table..... 9
-

Changes from Original (January 2016) to Revision A **Page**

- 已将“产品预览”更改为“量产数据” 1
-

5 Device Comparison Table

PRODUCT	DESCRIPTION
MUX508	8-channel, single-ended analog multiplexer (8:1 mux)
MUX509	4-channel differential or dual 4:1 single-ended analog multiplexer (8:2 mux)

6 Pin Configuration and Functions

**MUX508: PW and D Packages
16-Pin TSSOP and SOIC
Top View**

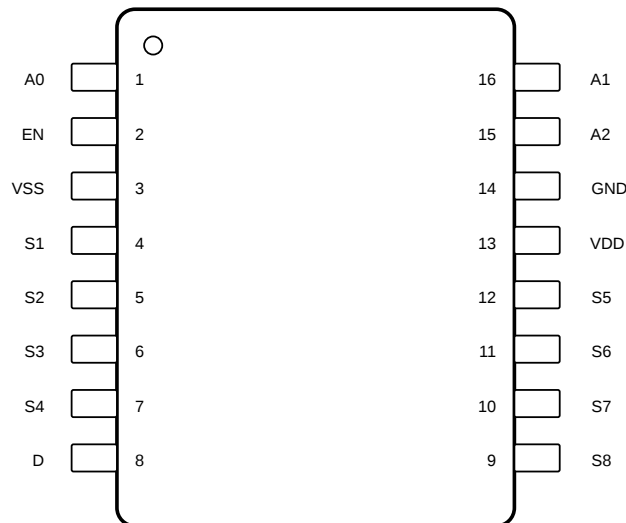

Pin Functions: MUX508

PIN		TYPE	DESCRIPTION
NAME	NO.		
A0	1	Digital input	Address line 0
A1	16	Digital input	Address line 1
A2	15	Digital input	Address line 2
D	8	Analog input or output	Drain pin. Can be an input or output.
EN	2	Digital input	Active high digital input. When this pin is low, all switches are turned off. When this pin is high, the A[2:0] logic inputs determine which switch is turned on.
GND	14	Power supply	Ground (0 V) reference
S1	4	Analog input or output	Source pin 1. Can be an input or output.
S2	5	Analog input or output	Source pin 2. Can be an input or output.
S3	6	Analog input or output	Source pin 3. Can be an input or output.
S4	7	Analog input or output	Source pin 4. Can be an input or output.
S5	12	Analog input or output	Source pin 5. Can be an input or output.
S6	11	Analog input or output	Source pin 6. Can be an input or output.
S7	10	Analog input or output	Source pin 7. Can be an input or output.
S8	9	Analog input or output	Source pin 8. Can be an input or output.
VDD	13	Power supply	Positive power supply. This pin is the most positive power-supply potential. For reliable operation, connect a decoupling capacitor ranging from 0.1 μ F to 10 μ F between VDD and GND.
VSS	3	Power supply	Negative power supply. This pin is the most negative power-supply potential. In single-supply applications, this pin can be connected to ground. For reliable operation, connect a decoupling capacitor ranging from 0.1 μ F to 10 μ F between VSS and GND.

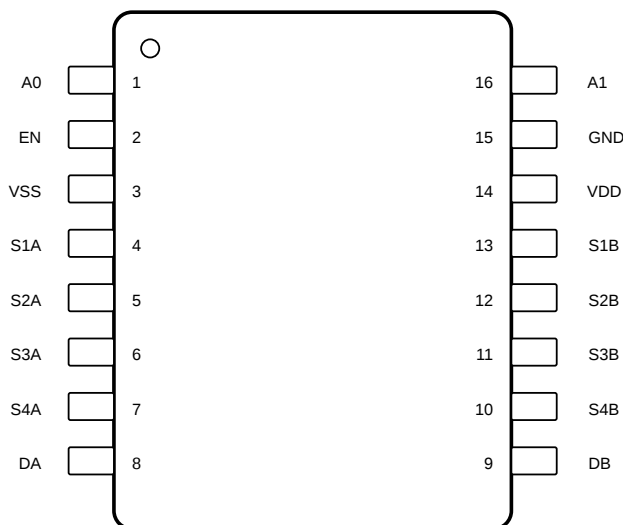
**MUX509: PW and D Packages
 16-Pin TSSOP and SOIC
 Top View**

Pin Functions: MUX509

PIN		TYPE	DESCRIPTION
NAME	NO.		
A0	1	Digital input	Address line 0
A1	16	Digital input	Address line 1
DA	8	Analog input or output	Drain pin A. Can be an input or output.
DB	9	Analog input or output	Drain pin B. Can be an input or output.
EN	2	Digital input	Active high digital input. When this pin is low, all switches are turned off. When this pin is high, the A[1:0] logic inputs determine which pair of switches is turned on.
GND	15	Power supply	Ground (0 V) reference
S1A	4	Analog input or output	Source pin 1A. Can be an input or output.
S2A	5	Analog input or output	Source pin 2A. Can be an input or output.
S3A	6	Analog input or output	Source pin 3A. Can be an input or output.
S4A	7	Analog input or output	Source pin 4A. Can be an input or output.
S1B	13	Analog input or output	Source pin 1B. Can be an input or output.
S2B	12	Analog input or output	Source pin 2B. Can be an input or output.
S3B	11	Analog input or output	Source pin 3B. Can be an input or output.
S4B	10	Analog input or output	Source pin 4B. Can be an input or output.
VDD	14	Power supply	Positive power supply. This pin is the most positive power supply potential. For reliable operation, connect a decoupling capacitor ranging from 0.1 μ F to 10 μ F between VDD and GND.
VSS	3	Power supply	Negative power supply. This pin is the most negative power supply potential. In single-supply applications, this pin can be connected to ground. For reliable operation, connect a decoupling capacitor ranging from 0.1 μ F to 10 μ F between VSS and GND.

7 Specifications

7.1 Absolute Maximum Ratings

 over operating free-air temperature range (unless otherwise noted)⁽¹⁾

		MIN	MAX	UNIT
Supply voltage	V_{DD}	-0.3	40	V
	V_{SS}	-40	0.3	
	$V_{DD} - V_{SS}$		40	
Digital input pins ⁽²⁾	EN, A0, A1, A2 pins	Voltage	$V_{SS} - 0.3$ $V_{DD} + 0.3$	V
		Current	-30 30	mA
Analog input pins ⁽²⁾	Sx, SxA, SxB pins	Voltage	$V_{SS} - 2$ $V_{DD} + 2$	V
		Current	-30 30	mA
Analog output pins ⁽²⁾	D, DA, DB pins	Voltage	$V_{SS} - 2$ $V_{DD} + 2$	V
		Current	-30 30	mA
Temperature	Operating, T_A	-55	150	°C
	Junction, T_J		150	
	Storage, T_{stg}	-65	150	

- (1) Stresses beyond those listed under *Absolute Maximum Ratings* may cause permanent damage to the device. These are stress ratings only, which do not imply functional operation of the device at these or any other conditions beyond those indicated under *Recommended Operating Conditions*. Exposure to absolute-maximum-rated conditions for extended periods may affect device reliability.
- (2) Only one pin at a time

7.2 ESD Ratings

		VALUE	UNIT
$V_{(ESD)}$	Electrostatic discharge	Human-body model (HBM), per ANSI/ESDA/JEDEC JS-001 ⁽¹⁾	2000
		Charged-device model (CDM), per JEDEC specification JESD22-C101 ⁽²⁾	500

- (1) JEDEC document JEP155 states that 500-V HBM allows safe manufacturing with a standard ESD control process.
- (2) JEDEC document JEP157 states that 250-V CDM allows safe manufacturing with a standard ESD control process.

7.3 Recommended Operating Conditions

		MIN	NOM	MAX	UNIT
V_{DD} ⁽¹⁾	Positive power-supply voltage	Dual supply	5	18	V
		Single supply	10	36	
V_{SS} ⁽²⁾	Negative power-supply voltage (dual supply)	-5		-18	V
$V_{DD} - V_{SS}$	Supply voltage	10		36	V
V_S	Source pins voltage ⁽³⁾	V_{SS}		V_{DD}	V
V_D	Drain pins voltage	V_{SS}		V_{DD}	V
V_{EN}	Enable pin voltage	V_{SS}		V_{DD}	V
V_A	Address pins voltage	V_{SS}		V_{DD}	V
I_{CH}	Channel current ($T_A = 25^\circ\text{C}$)	-25		25	mA
T_A	Operating temperature	-40		125	°C

- (1) When $V_{SS} = 0$ V, V_{DD} can range from 10 V to 36 V.
- (2) V_{DD} and V_{SS} can be any value as long as $10 \text{ V} \leq (V_{DD} - V_{SS}) \leq 36 \text{ V}$, and $V_{DD} \geq 5 \text{ V}$.
- (3) V_S is the voltage on all the S pins.

7.4 Thermal Information

THERMAL METRIC ⁽¹⁾		MUX50x		UNIT
		PW (TSSOP)	D (SOIC)	
		16 PINS	16 PINS	
R _{θJA}	Junction-to-ambient thermal resistance	103.8	78.3	°C/W
R _{θJC(top)}	Junction-to-case (top) thermal resistance	36.8	37.2	°C/W
R _{θJB}	Junction-to-board thermal resistance	49.8	35.7	°C/W
ψ _{JT}	Junction-to-top characterization parameter	2.7	8.2	°C/W
ψ _{JB}	Junction-to-board characterization parameter	49.1	35.4	°C/W
R _{θJC(bot)}	Junction-to-case (bottom) thermal resistance	n/a	n/a	°C/W

(1) For more information about traditional and new thermal metrics, see the [Semiconductor and IC Package Thermal Metrics](#).

7.5 Electrical Characteristics: Dual Supply

at T_A = 25°C, V_{DD} = 15 V, and V_{SS} = -15 V (unless otherwise noted)

PARAMETER	TEST CONDITIONS	MIN	TYP	MAX	UNIT			
ANALOG SWITCH								
Analog signal range	T _A = -40°C to +125°C	V _{SS}		V _{DD}	V			
R _{ON}	On-resistance	V _S = 0 V, I _{CH} = 1 mA		125	170	Ω		
				145	200			
	V _S = ±10 V, I _{CH} = 1 mA	T _A = -40°C to +85°C			230			
		T _A = -40°C to +125°C			250			
ΔR _{ON}	On-resistance mismatch between channels	V _S = ±10 V, I _{CH} = 1 mA		2.4	6	Ω		
			T _A = -40°C to +85°C				9	
			T _A = -40°C to +125°C				11	
R _{FLAT}	On-resistance flatness	V _S = 10 V, 0 V, -10 V		22	45	Ω		
			T _A = -40°C to +85°C				53	
			T _A = -40°C to +125°C				58	
On-resistance drift	V _S = 0 V		0.52		%/°C			
I _{S(OFF)}	Input leakage current	Switch state is off, V _S = ±10 V, V _D = ±10 V ⁽¹⁾		-1	0.01	1	nA	
			T _A = -40°C to +85°C					10
			T _A = -40°C to +125°C					25
I _{D(OFF)}	Output off leakage current	Switch state is off, V _S = ±10 V, V _D = ±10 V ⁽¹⁾		-1	0.01	1	nA	
			T _A = -40°C to +85°C					10
			T _A = -40°C to +125°C					50
I _{D(ON)}	Output on leakage current	Switch state is on, V _D = ±10 V, V _S = floating		-1	0.01	1	nA	
			T _A = -40°C to +85°C					10
			T _A = -40°C to +125°C					50
LOGIC INPUT								
V _{IH}	High-level input voltage	2.0			V			
V _{IL}	Low-level input voltage			0.8	V			
I _D	Input current			0.15	μA			

(1) When V_S is positive, V_D is negative, and vice versa.

Electrical Characteristics: Dual Supply (continued)

 at $T_A = 25^\circ\text{C}$, $V_{DD} = 15\text{ V}$, and $V_{SS} = -15\text{ V}$ (unless otherwise noted)

PARAMETER	TEST CONDITIONS	MIN	TYP	MAX	UNIT
SWITCH DYNAMICS⁽²⁾					
t_{ON} Enable turn-on time	$V_S = \pm 10\text{ V}$, $R_L = 300\ \Omega$, $C_L = 35\text{ pF}$		88	136	ns
		$T_A = -40^\circ\text{C to } +85^\circ\text{C}$		144	
		$T_A = -40^\circ\text{C to } +125^\circ\text{C}$		151	
t_{OFF} Enable turn-off time	$V_S = \pm 10\text{ V}$, $R_L = 300\ \Omega$, $C_L = 35\text{ pF}$		63	75	ns
		$T_A = -40^\circ\text{C to } +85^\circ\text{C}$		83	
		$T_A = -40^\circ\text{C to } +125^\circ\text{C}$		90	
t_t Transition time	$V_S = 10\text{ V}$, $R_L = 300\ \Omega$, $C_L = 35\text{ pF}$		92	143	ns
		$T_A = -40^\circ\text{C to } +85^\circ\text{C}$		151	
		$T_A = -40^\circ\text{C to } +125^\circ\text{C}$		157	
t_{BBM} Break-before-make time delay	$V_S = 10\text{ V}$, $R_L = 300\ \Omega$, $C_L = 35\text{ pF}$, $T_A = -40^\circ\text{C to } +125^\circ\text{C}$	30	54		ns
Q_J Charge injection	$C_L = 1\text{ nF}$, $R_S = 0\ \Omega$	$V_S = 0\text{ V}$	0.3		pC
		$V_S = -15\text{ V to } +15\text{ V}$	± 0.6		
Off-isolation	$R_L = 50\ \Omega$, $V_S = 1\text{ V}_{RMS}$, $f = 1\text{ MHz}$	Nonadjacent channel to D, DA, DB	-96		dB
		Adjacent channel to D, DA, DB	-85		
Channel-to-channel crosstalk	$R_L = 50\ \Omega$, $V_S = 1\text{ V}_{RMS}$, $f = 1\text{ MHz}$	Nonadjacent channels	-96		dB
		Adjacent channels	-88		
$C_{S(OFF)}$ Input off-capacitance	$f = 1\text{ MHz}$, $V_S = 0\text{ V}$		2.4	2.9	pF
$C_{D(OFF)}$ Output off-capacitance	$f = 1\text{ MHz}$, $V_S = 0\text{ V}$	MUX508	7.5	8.4	pF
		MUX509	4.3	5	
$C_{D(ON)}$ Input/Output on-capacitance	$f = 1\text{ MHz}$, $V_S = 0\text{ V}$	MUX508	9.4	10.6	pF
		MUX509	6.7	7.7	
POWER SUPPLY					
V_{DD} supply current	All $V_A = 0\text{ V}$ or 3.3 V , $V_S = 0\text{ V}$, $V_{EN} = 3.3\text{ V}$,		45	59	μA
		$T_A = -40^\circ\text{C to } +85^\circ\text{C}$		62	
		$T_A = -40^\circ\text{C to } +125^\circ\text{C}$		83	
V_{SS} supply current	All $V_A = 0\text{ V}$ or 3.3 V , $V_S = 0\text{ V}$, $V_{EN} = 3.3\text{ V}$,		25	34	μA
		$T_A = -40^\circ\text{C to } +85^\circ\text{C}$		37	
		$T_A = -40^\circ\text{C to } +125^\circ\text{C}$		57	

(2) Specified by design, not production tested.

7.6 Electrical Characteristics: Single Supply

at $T_A = 25^\circ\text{C}$, $V_{DD} = 12\text{ V}$, and $V_{SS} = 0\text{ V}$ (unless otherwise noted)⁽¹⁾

PARAMETER		TEST CONDITIONS		MIN	TYP	MAX	UNIT
ANALOG SWITCH							
Analog signal range		$T_A = -40^\circ\text{C}$ to $+125^\circ\text{C}$		V_{SS}		V_{DD}	V
R_{ON}	On-resistance	$V_S = 10\text{ V}$, $I_{CH} = 1\text{ mA}$		235	340		Ω
			$T_A = -40^\circ\text{C}$ to $+85^\circ\text{C}$			390	
			$T_A = -40^\circ\text{C}$ to $+125^\circ\text{C}$			430	
ΔR_{ON}	On-resistance match	$V_S = 10\text{ V}$, $I_{CH} = 1\text{ mA}$		3.1	12		Ω
			$T_A = -40^\circ\text{C}$ to $+85^\circ\text{C}$			19	
			$T_A = -40^\circ\text{C}$ to $+125^\circ\text{C}$			23	
On-resistance drift		$V_S = 10\text{ V}$			0.47		%/ $^\circ\text{C}$
$I_{S(OFF)}$	Input leakage current	Switch state is off, $V_S = 1\text{ V}$ and $V_D = 10\text{ V}$, or $V_S = 10\text{ V}$ and $V_D = 1\text{ V}$ ⁽²⁾		-1	0.01	1	nA
			$T_A = -40^\circ\text{C}$ to $+85^\circ\text{C}$	-10		10	
			$T_A = -40^\circ\text{C}$ to $+125^\circ\text{C}$	-25		25	
$I_{D(OFF)}$	Output off leakage current	Switch state is off, $V_S = 1\text{ V}$ and $V_D = 10\text{ V}$, or $V_S = 10\text{ V}$ and $V_D = 1\text{ V}$ ⁽²⁾		-1	0.01	1	nA
			$T_A = -40^\circ\text{C}$ to $+85^\circ\text{C}$	-10		10	
			$T_A = -40^\circ\text{C}$ to $+125^\circ\text{C}$	-50		50	
$I_{D(ON)}$	Output on leakage current	Switch state is on, $V_D = 1\text{ V}$ and 10 V , $V_S = \text{floating}$		-1	0.01	1	nA
			$T_A = -40^\circ\text{C}$ to $+85^\circ\text{C}$	-10		10	
			$T_A = -40^\circ\text{C}$ to $+125^\circ\text{C}$	-50		50	
LOGIC INPUT							
V_{IH}	High-level input voltage			2.0			V
V_{IL}	Low-level input voltage					0.8	V
I_D	Input current					0.15	μA
SWITCH DYNAMIC CHARACTERISTICS							
t_{ON}	Enable turn-on time	$V_S = 8\text{ V}$, $R_L = 300\ \Omega$, $C_L = 35\text{ pF}$			85	140	ns
			$T_A = -40^\circ\text{C}$ to $+85^\circ\text{C}$			145	
			$T_A = -40^\circ\text{C}$ to $+125^\circ\text{C}$			149	
t_{OFF}	Enable turn-off time	$V_S = 8\text{ V}$, $R_L = 300\ \Omega$, $C_L = 35\text{ pF}$			48	83	ns
			$T_A = -40^\circ\text{C}$ to $+85^\circ\text{C}$			94	
			$T_A = -40^\circ\text{C}$ to $+125^\circ\text{C}$			102	
t_t	Transition time	$V_S = 8\text{ V}$, $C_L = 35\text{ pF}$			87	147	ns
		$V_S = 8\text{ V}$, $R_L = 300\ \Omega$, $C_L = 35\text{ pF}$,	$T_A = -40^\circ\text{C}$ to $+85^\circ\text{C}$			153	
		$V_S = 8\text{ V}$, $R_L = 300\ \Omega$, $C_L = 35\text{ pF}$,	$T_A = -40^\circ\text{C}$ to $+125^\circ\text{C}$			155	
t_{BBM}	Break-before-make time delay	$V_S = 8\text{ V}$, $R_L = 300\ \Omega$, $C_L = 35\text{ pF}$, $T_A = -40^\circ\text{C}$ to $+125^\circ\text{C}$		30	54		ns
Q_J	Charge injection	$C_L = 1\text{ nF}$, $R_S = 0\ \Omega$	$V_S = 6\text{ V}$		0.15		pC
			$V_S = 0\text{ V}$ to 12 V ,			± 0.4	
	Off-isolation	$R_L = 50\ \Omega$, $V_S = 1\text{ V}_{RMS}$, $f = 1\text{ MHz}$	Nonadjacent channel to D, DA, DB		-96		dB
			Adjacent channel to D, DA, DB			-85	
	Channel-to-channel crosstalk	$R_L = 50\ \Omega$, $V_S = 1\text{ V}_{RMS}$, $f = 1\text{ MHz}$	Nonadjacent channels		-96		dB
			Adjacent channels			-88	
$C_{S(OFF)}$	Input off-capacitance	$f = 1\text{ MHz}$, $V_S = 6\text{ V}$			2.7	3.2	pF
$C_{D(OFF)}$	Output off-capacitance	$f = 1\text{ MHz}$, $V_S = 6\text{ V}$		MUX508	9.1	10	pF
				MUX509	5	5.7	
$C_{D(ON)}$	Input/Output on-capacitance	$f = 1\text{ MHz}$, $V_S = 6\text{ V}$		MUX508	10.8	12	pF
				MUX509	6.9	8	

(1) Specified by design, not production tested.

(2) When V_S is 1 V, V_D is 10 V, and vice versa.

MUX508, MUX509

ZHCSEV2C – JANUARY 2016 – REVISED SEPTEMBER 2016

www.ti.com.cn
Electrical Characteristics: Single Supply (continued)

 at $T_A = 25^\circ\text{C}$, $V_{DD} = 12\text{ V}$, and $V_{SS} = 0\text{ V}$ (unless otherwise noted)⁽¹⁾

PARAMETER	TEST CONDITIONS	MIN	TYP	MAX	UNIT
POWER SUPPLY					
V_{DD} supply current	All $V_A = 0\text{ V}$ or 3.3 V , $V_S = 0\text{ V}$, $V_{EN} = 3.3\text{ V}$		42	53	μA
		$T_A = -40^\circ\text{C}$ to $+85^\circ\text{C}$		56	
		$T_A = -40^\circ\text{C}$ to $+125^\circ\text{C}$		77	
V_{SS} supply current	All $V_A = 0\text{ V}$ or 3.3 V , $V_S = 0\text{ V}$, $V_{EN} = 3.3\text{ V}$		23	38	μA
		$T_A = -40^\circ\text{C}$ to $+85^\circ\text{C}$		31	
		$T_A = -40^\circ\text{C}$ to $+125^\circ\text{C}$		51	

7.7 Typical Characteristics

at $T_A = 25^\circ\text{C}$, $V_{DD} = 15\text{ V}$, and $V_{SS} = -15\text{ V}$ (unless otherwise noted)

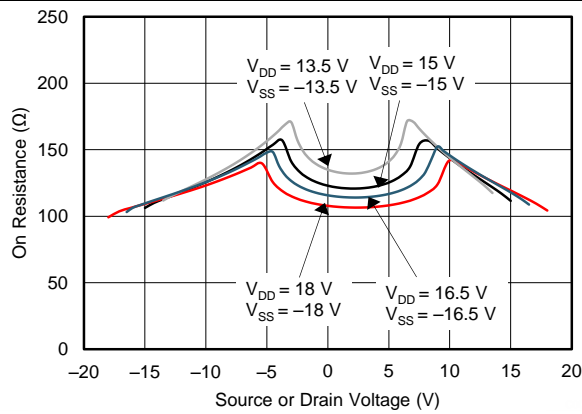
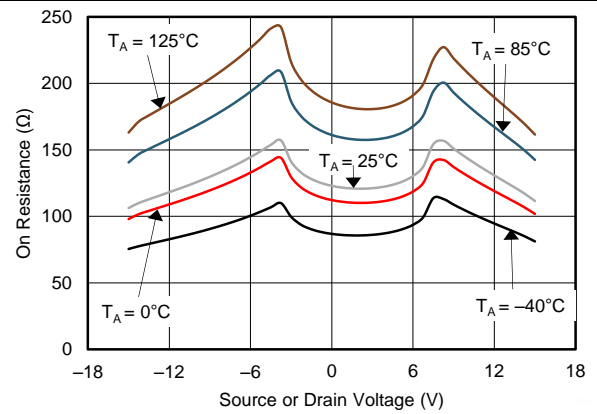

Figure 1. On-Resistance vs Source or Drain Voltage



$V_{DD} = 15\text{ V}$, $V_{SS} = -15\text{ V}$

Figure 2. On-Resistance vs Source or Drain Voltage

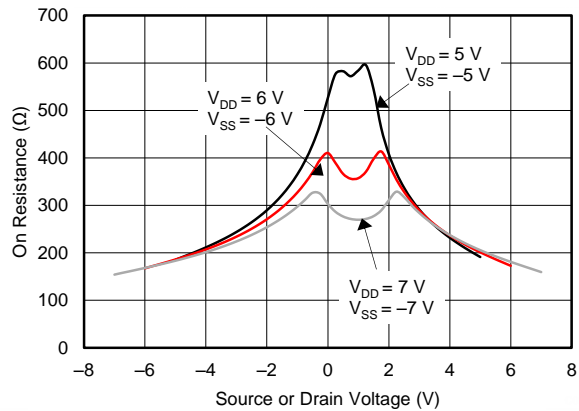
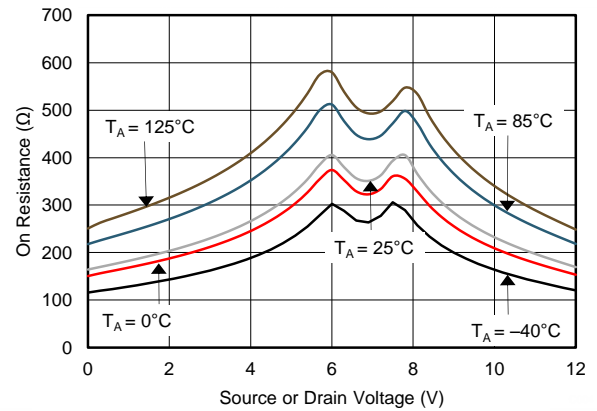

Figure 3. On-Resistance vs Source or Drain Voltage



$V_{DD} = 12\text{ V}$, $V_{SS} = 0\text{ V}$

Figure 4. On-Resistance vs Source or Drain Voltage

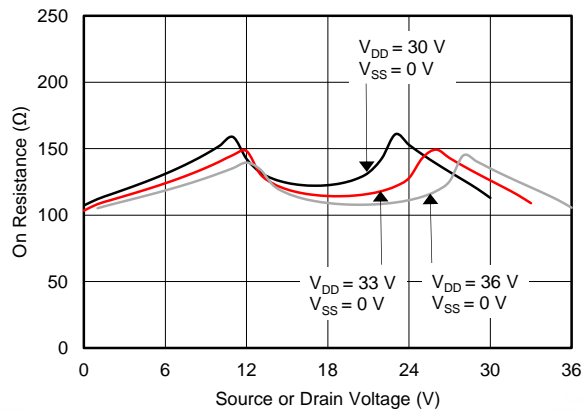

Figure 5. On-Resistance vs Source or Drain Voltage

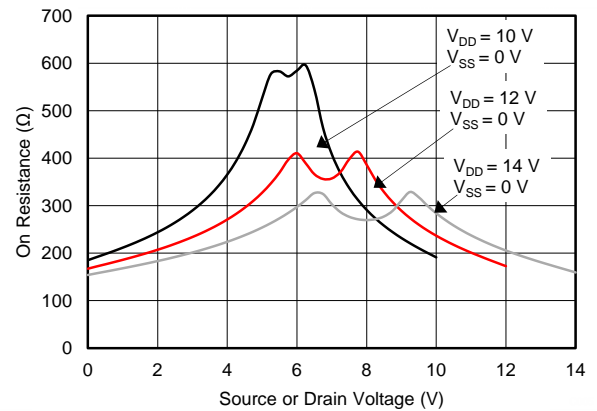
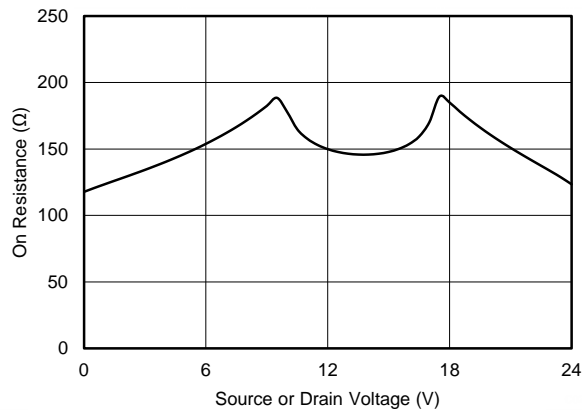

Figure 6. On-Resistance vs Source or Drain Voltage

Typical Characteristics (continued)

at $T_A = 25^\circ\text{C}$, $V_{DD} = 15\text{ V}$, and $V_{SS} = -15\text{ V}$ (unless otherwise noted)



$V_{DD} = 24\text{ V}$, $V_{SS} = 0\text{ V}$

Figure 7. On-Resistance vs Source or Drain Voltage

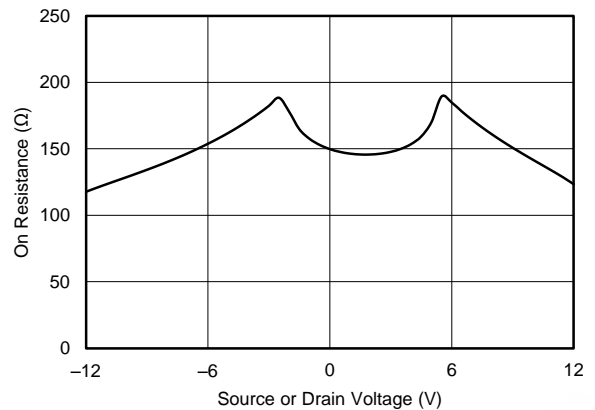

$V_{DD} = 12\text{ V}$, $V_{SS} = -12\text{ V}$

Figure 8. On-Resistance vs Source or Drain Voltage

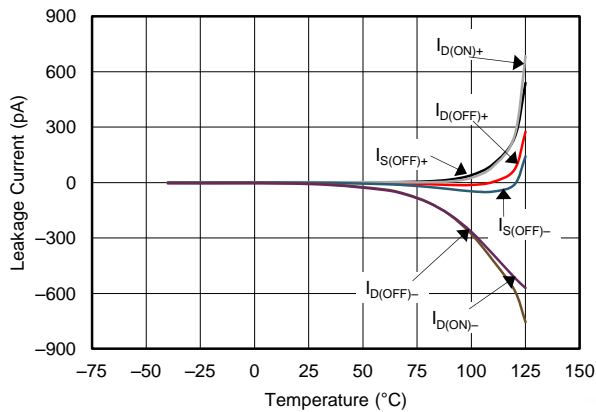

$V_{DD} = 15\text{ V}$, $V_{SS} = -15\text{ V}$

Figure 9. Leakage Current vs Temperature

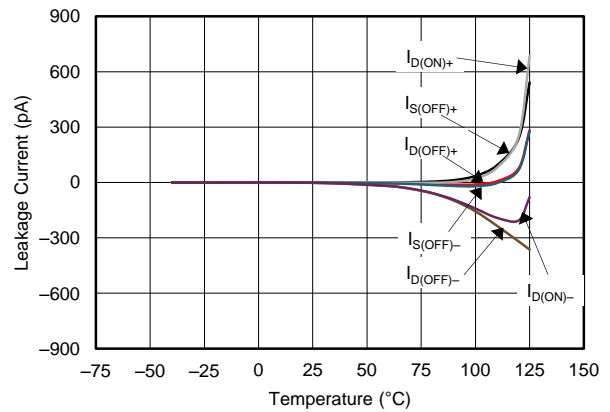

$V_{DD} = 12\text{ V}$, $V_{SS} = 0\text{ V}$

Figure 10. Leakage Current vs Temperature

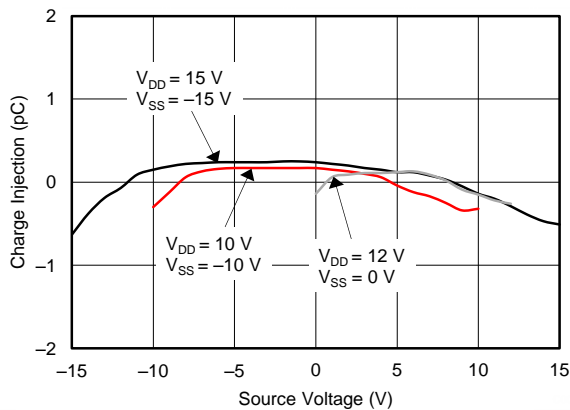

MUX508, source-to-drain

Figure 11. Charge Injection vs Source Voltage

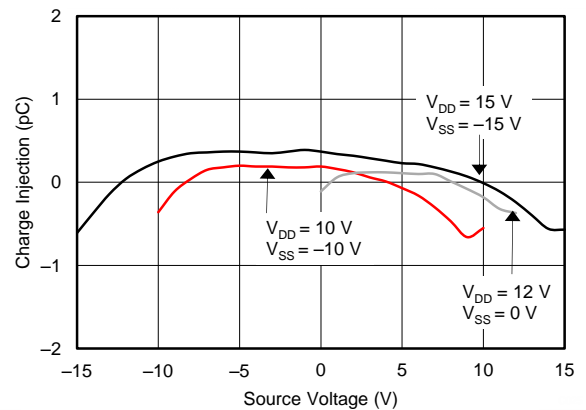

MUX509, source-to-drain

Figure 12. Charge Injection vs Source Voltage

Typical Characteristics (continued)

at $T_A = 25^\circ\text{C}$, $V_{DD} = 15\text{ V}$, and $V_{SS} = -15\text{ V}$ (unless otherwise noted)

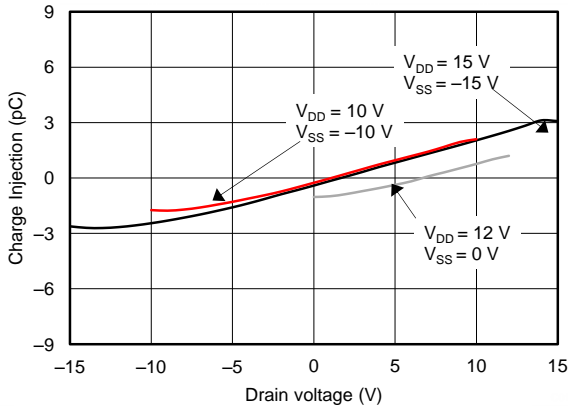

Drain-to-source

Figure 13. Charge Injection vs Source or Drain Voltage

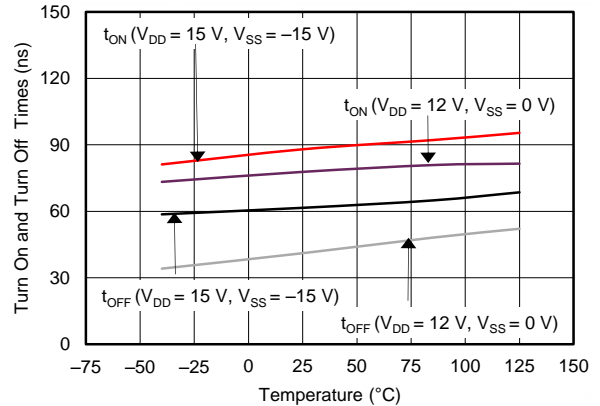

Figure 14. Turn-On and Turn-Off Times vs Temperature

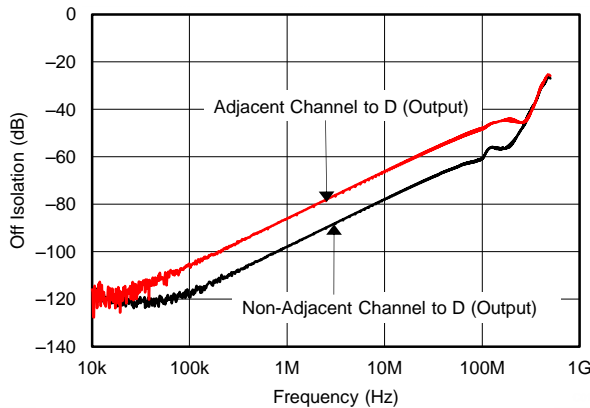

Figure 15. Off Isolation vs Frequency

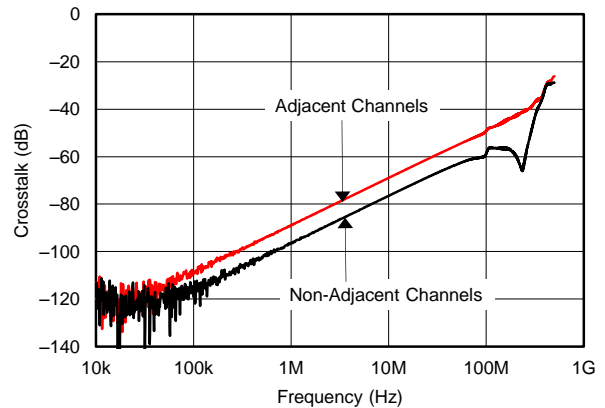

Figure 16. Crosstalk vs Frequency

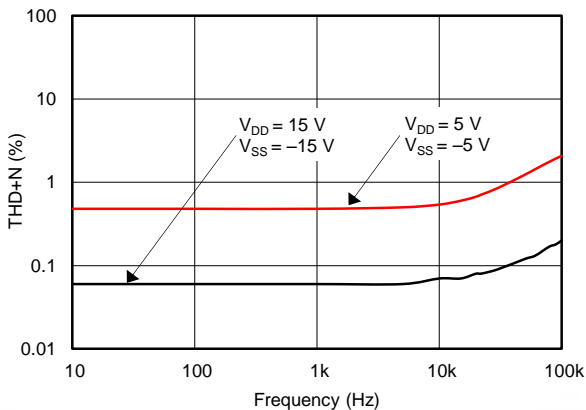

Figure 17. THD+N vs Frequency

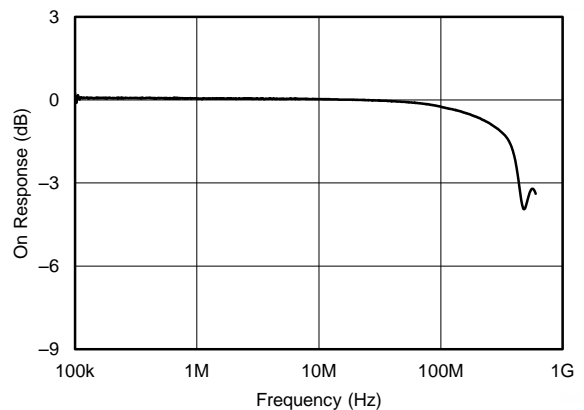

Figure 18. On Response vs Frequency

MUX508, MUX509

ZHCSEV2C – JANUARY 2016 – REVISED SEPTEMBER 2016

www.ti.com.cn

Typical Characteristics (continued)

at $T_A = 25^\circ\text{C}$, $V_{DD} = 15\text{ V}$, and $V_{SS} = -15\text{ V}$ (unless otherwise noted)

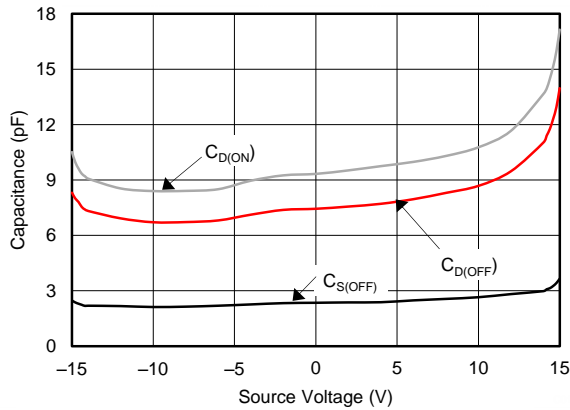

MUX508, $V_{DD} = 15\text{ V}$, $V_{SS} = -15\text{ V}$

Figure 19. Capacitance vs Source Voltage

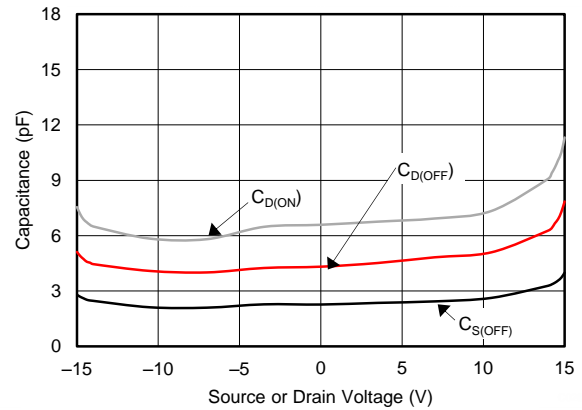

MUX509, $V_{DD} = 15\text{ V}$, $V_{SS} = -15\text{ V}$

Figure 20. Capacitance vs Source Voltage

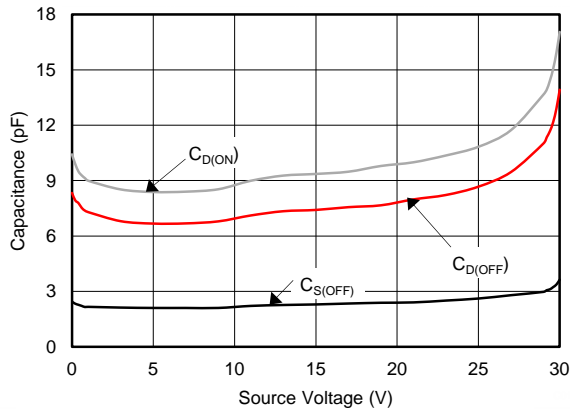

MUX508, $V_{DD} = 30\text{ V}$, $V_{SS} = 0\text{ V}$

Figure 21. Capacitance vs Source Voltage

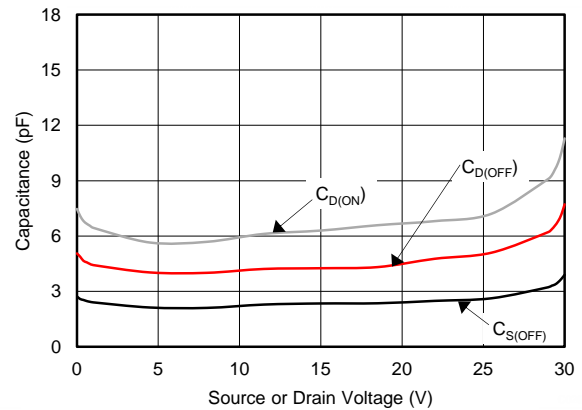

MUX509, $V_{DD} = 30\text{ V}$, $V_{SS} = 0\text{ V}$

Figure 22. Capacitance vs Source Voltage

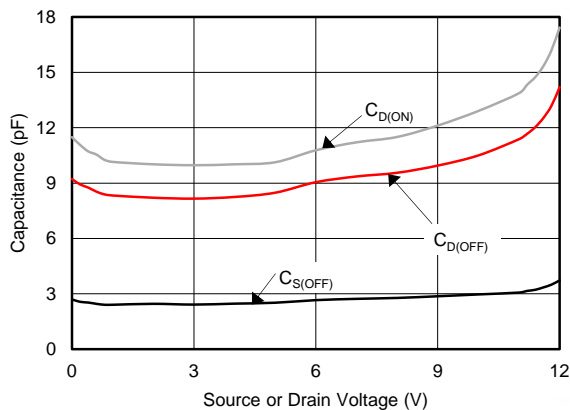

MUX508, $V_{DD} = 12\text{ V}$, $V_{SS} = 0\text{ V}$

Figure 23. Capacitance vs Source Voltage

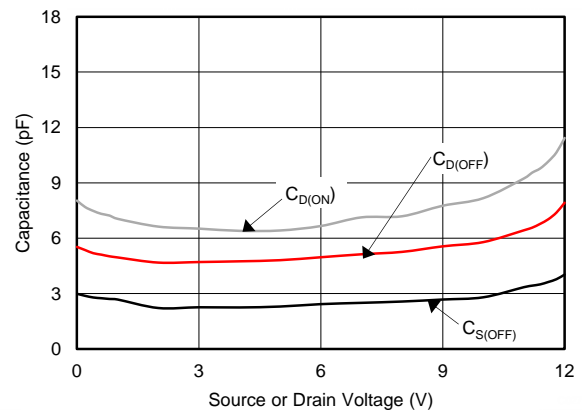

MUX509, $V_{DD} = 12\text{ V}$, $V_{SS} = 0\text{ V}$

Figure 24. Capacitance vs Source Voltage

Typical Characteristics (continued)

at $T_A = 25^\circ\text{C}$, $V_{DD} = 15\text{ V}$, and $V_{SS} = -15\text{ V}$ (unless otherwise noted)

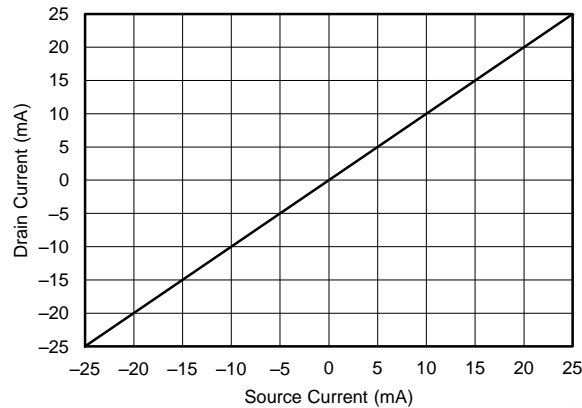

Figure 25. Source Current vs Drain Current

8 Parameter Measurement Information

8.1 Truth Tables

Table 1 and Table 2 show the truth tables for the MUX508 and MUX509, respectively.

Table 1. MUX508 Truth Table

EN	A2	A1	A0	STATE
0	X ⁽¹⁾	X ⁽¹⁾	X ⁽¹⁾	All channels are off
1	0	0	0	Channel 1 on
1	0	0	1	Channel 2 on
1	0	1	0	Channel 3 on
1	0	1	1	Channel 4 on
1	1	0	0	Channel 5 on
1	1	0	1	Channel 6 on
1	1	1	0	Channel 7 on
1	1	1	1	Channel 8 on

(1) X denotes *don't care*.

Table 2. MUX509 Truth Table

EN	A1	A0	STATE
0	X ⁽¹⁾	X ⁽¹⁾	All channels are off
1	0	0	Channels 1A and 1B on
1	0	1	Channels 2A and 2B on
1	1	0	Channels 3A and 3B on
1	1	1	Channels 4A and 4B on

(1) X denotes *don't care*.

8.2 On-Resistance

The on-resistance of the MUX50x is the ohmic resistance across the source (Sx, SxA, or SxB) and drain (D, DA, or DB) pins of the device. The on-resistance varies with input voltage and supply voltage. The symbol R_{ON} is used to denote on-resistance. The measurement setup used to measure R_{ON} is shown in Figure 26. Voltage (V) and current (I_{CH}) are measured using this setup, and R_{ON} is computed as shown in Equation 1.

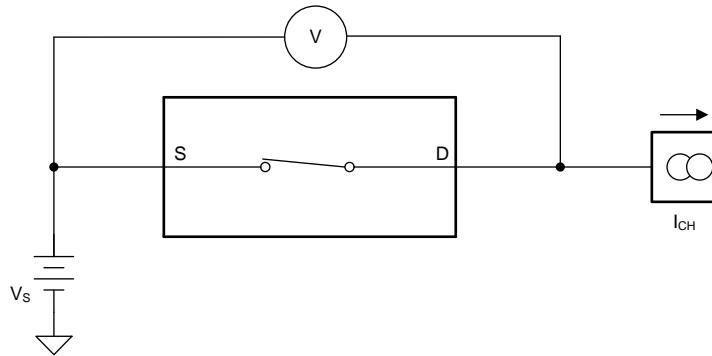

Figure 26. On-Resistance Measurement Setup

$$R_{ON} = V / I_{CH} \tag{1}$$

8.3 Off-Leakage Current

There are two types of leakage currents associated with a switch during the off state:

1. Source off-leakage current
2. Drain off-leakage current

Source off-leakage current is defined as the leakage current flowing into or out of the source pin when the switch is off. This current is denoted by the symbol $I_{S(OFF)}$.

Drain off-leakage current is defined as the leakage current flowing into or out of the drain pin when the switch is off. This current is denoted by the symbol $I_{D(OFF)}$.

The setup used to measure both types of off-leakage currents is shown in Figure 27.

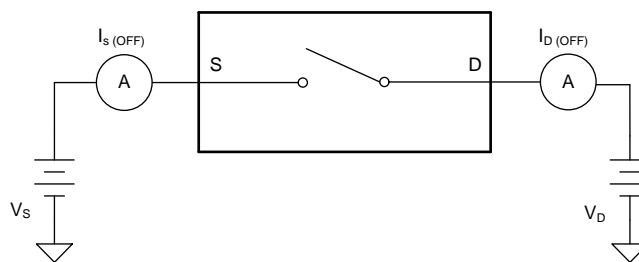

Figure 27. Off-Leakage Measurement Setup

8.4 On-Leakage Current

On-leakage current is defined as the leakage current that flows into or out of the drain pin when the switch is in the on state. The source pin is left floating during the measurement. Figure 28 shows the circuit used for measuring the on-leakage current, denoted by $I_{D(ON)}$.

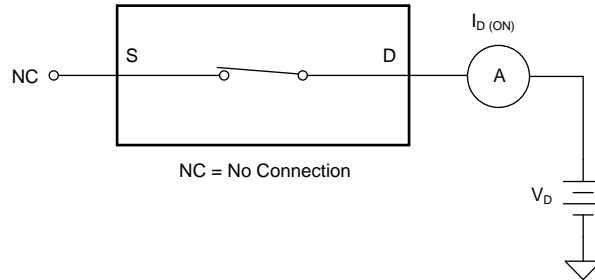
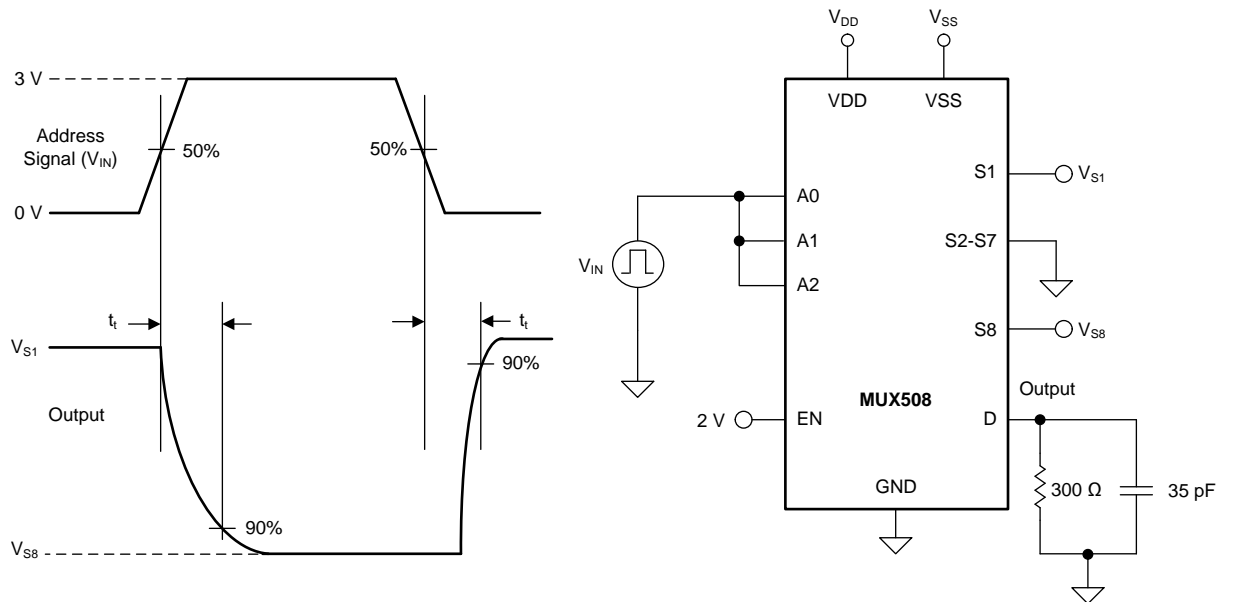

Figure 28. On-Leakage Measurement Setup

8.5 Transition Time

Transition time is defined as the time taken by the output of the MUX50x to rise or fall to 90% of the transition after the digital address signal has fallen or risen to the 50% of the transition. Figure 29 shows the setup used to measure transition time, denoted by the symbol t_t .



Copyright © 2016, Texas Instruments Incorporated

Figure 29. Transition-Time Measurement Setup

8.6 Break-Before-Make Delay

Break-before-make delay is a safety feature that prevents two inputs from connecting when the MUX50x is switching. The MUX50x output first breaks from the on-state switch before making the connection with the next on-state switch. The time delay between the *break* and the *make* is known as a break-before-make delay. [Figure 30](#) shows the setup used to measure break-before-make delay, denoted by the symbol t_{BBM} .

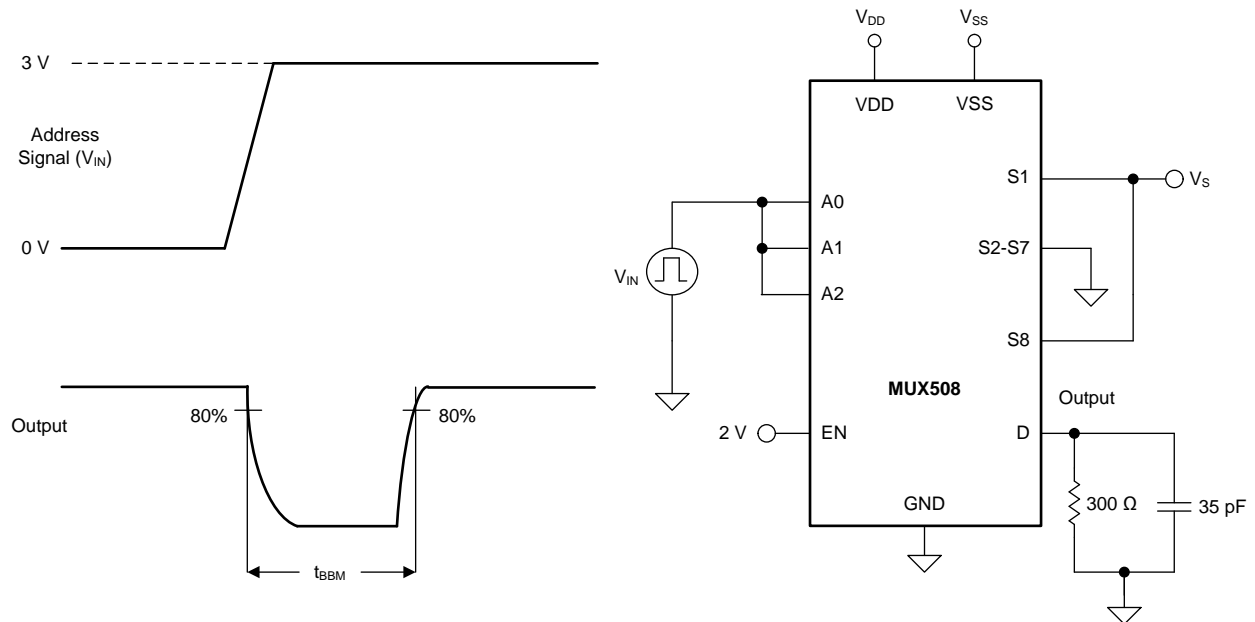

Copyright © 2016, Texas Instruments Incorporated

Figure 30. Break-Before-Make Delay Measurement Setup

8.7 Turn-On and Turn-Off Time

Turn-on time is defined as the time taken by the output of the MUX50x to rise to a 90% final value after the enable signal has risen to a 50% final value. Figure 31 shows the setup used to measure turn-on time. Turn-on time is denoted by the symbol t_{ON} .

Turn-off time is defined as the time taken by the output of the MUX50x to fall to a 10% initial value after the enable signal has fallen to a 50% initial value. Figure 31 shows the setup used to measure turn-off time. Turn-off time is denoted by the symbol t_{OFF} .

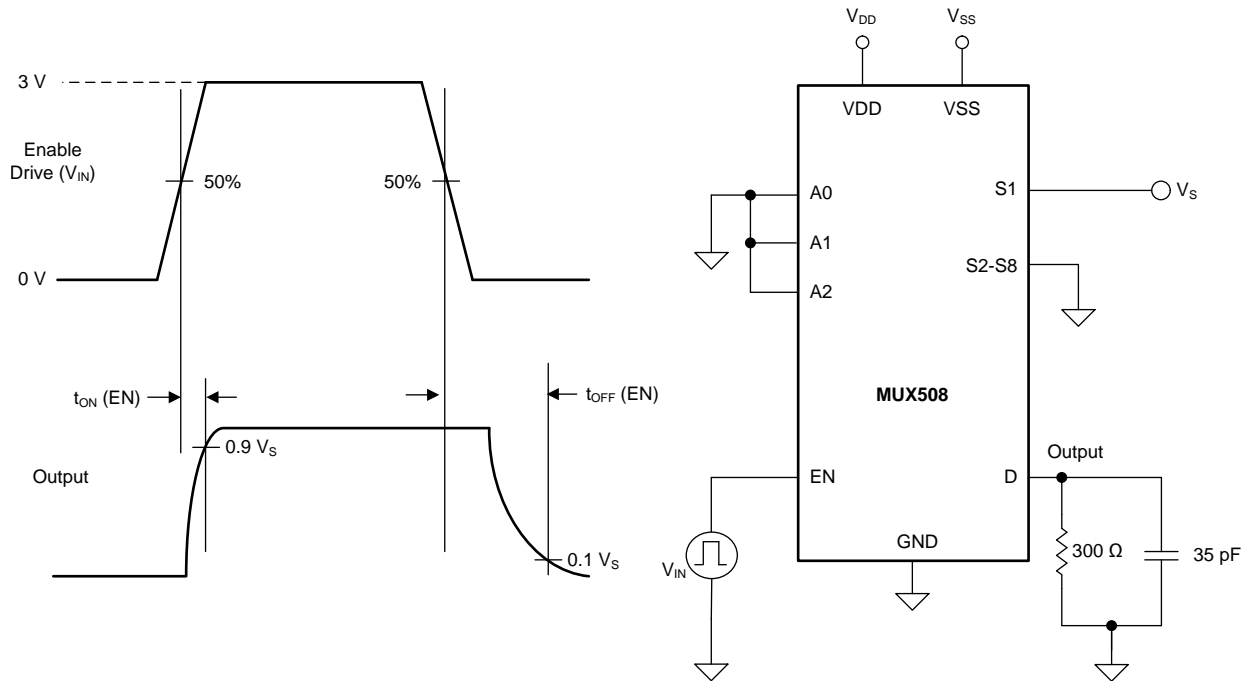

Copyright © 2016, Texas Instruments Incorporated

Figure 31. Turn-On and Turn-Off Time Measurement Setup

8.8 Charge Injection

The MUX50x have a simple transmission-gate topology. Any mismatch in capacitance between the NMOS and PMOS transistors results in a charge injected into the drain or source during the falling or rising edge of the gate signal. The amount of charge injected into the source or drain of the device is known as charge injection, and is denoted by the symbol Q_{INJ} . Figure 32 shows the setup used to measure charge injection.

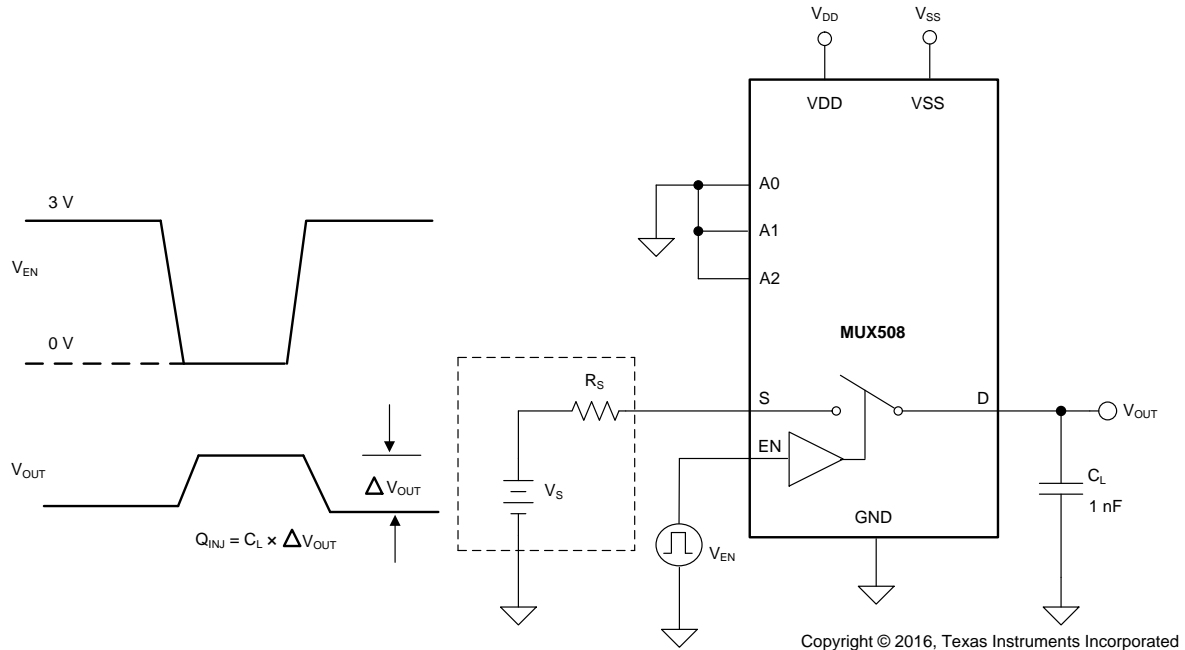

Figure 32. Charge-Injection Measurement Setup

8.9 Off Isolation

Off isolation is defined as the voltage at the drain pin (D, DA, or DB) of the MUX50x when a 1- V_{RMS} signal is applied to the source pin (Sx, SxA, or SxB) of an off-channel. Figure 33 shows the setup used to measure off isolation. Use Equation 2 to compute off isolation.

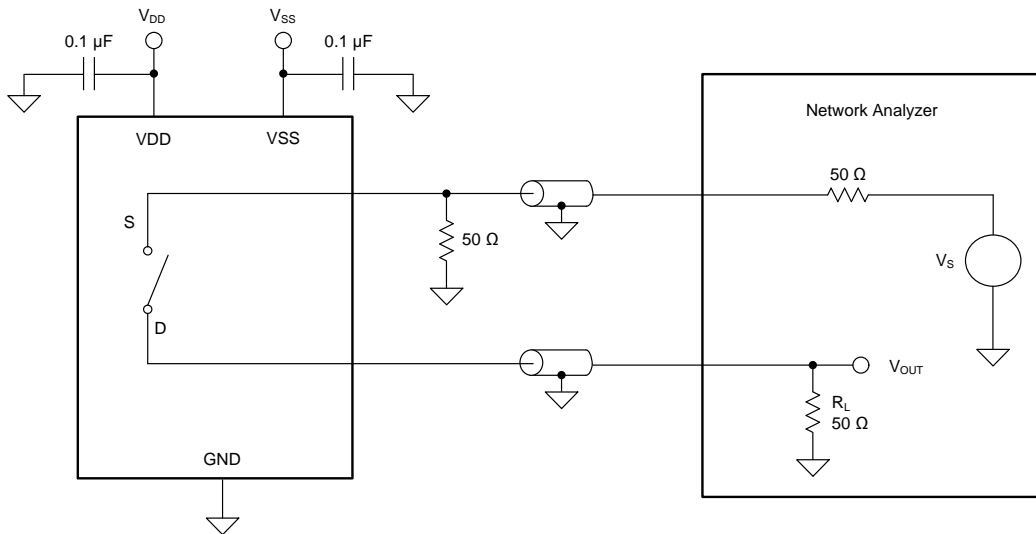

Figure 33. Off Isolation Measurement Setup

$$\text{Off Isolation} = 20 \cdot \text{Log} \left(\frac{V_{\text{OUT}}}{V_{\text{S}}} \right) \quad (2)$$

8.10 Channel-to-Channel Crosstalk

Channel-to-channel crosstalk is defined as the voltage at the source pin (Sx, SxA, or SxB) of an off-channel, when a 1- V_{RMS} signal is applied at the source pin of an on-channel. Figure 34 shows the setup used to measure, and Equation 3 is the equation used to compute, channel-to-channel crosstalk.

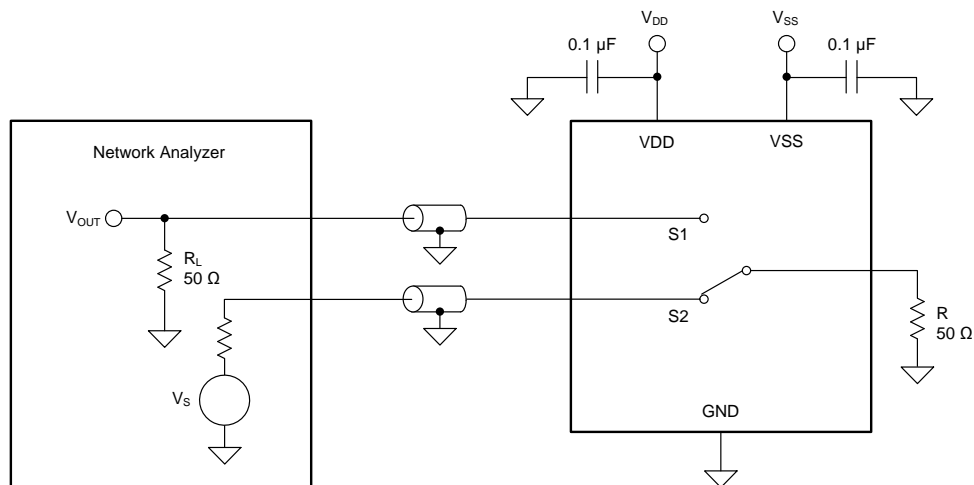

Figure 34. Channel-to-Channel Crosstalk Measurement Setup

$$\text{Channel-to-Channel Crosstalk} = 20 \cdot \text{Log} \left(\frac{V_{\text{OUT}}}{V_{\text{S}}} \right) \quad (3)$$

8.11 Bandwidth

Bandwidth is defined as the range of frequencies that are attenuated by < 3 dB when the input is applied to the source pin of an on-channel and the output is measured at the drain pin of the MUX50x. Figure 35 shows the setup used to measure bandwidth of the mux. Use Equation 4 to compute the attenuation.

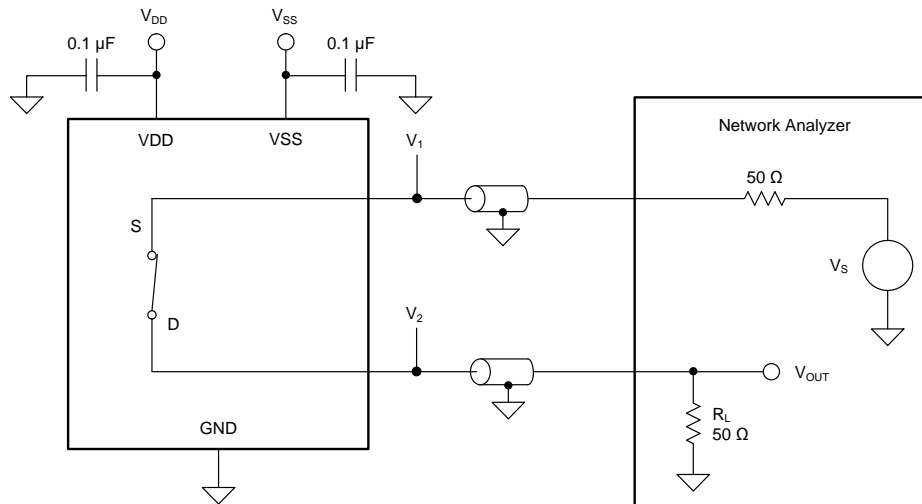

Figure 35. Bandwidth Measurement Setup

$$\text{Attenuation} = 20 \cdot \text{Log} \left(\frac{V_2}{V_1} \right) \quad (4)$$

8.12 THD + Noise

The total harmonic distortion (THD) of a signal is defined as the ratio of the sum of the powers of all harmonic components to the power of the fundamental frequency at the mux output. The on-resistance of the MUX50x varies with the amplitude of the input signal and results in distortion when the drain pin is connected to a low-impedance load. Total harmonic distortion plus noise is denoted as THD+N. Figure 36 shows the setup used to measure the THD+N of the MUX50x.

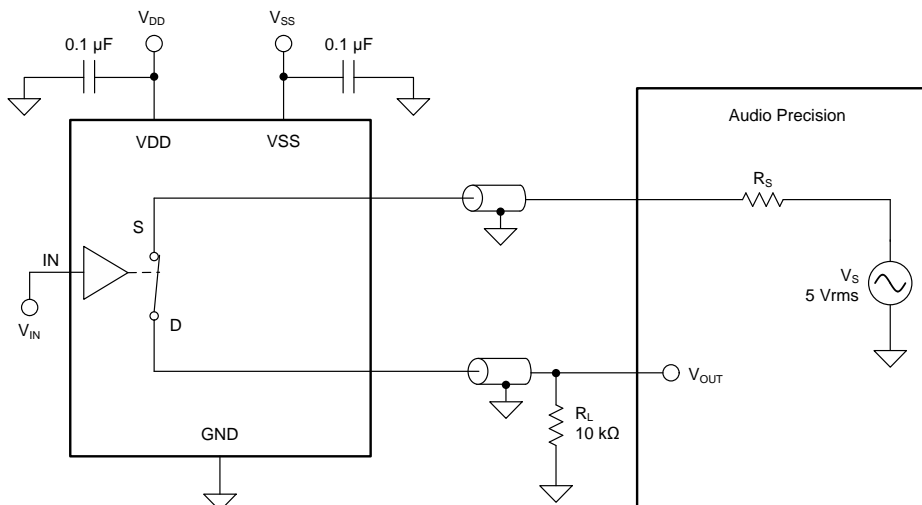

Figure 36. THD+N Measurement Setup

9 Detailed Description

9.1 Overview

The MUX50x are a family of analog multiplexers. The *Functional Block Diagram* section provides a top-level block diagram of both the MUX508 and MUX509. The MUX508 is an eight-channel, single-ended, analog mux. The MUX509 is a four-channel, differential or dual 4:1, single-ended, analog mux. Each channel is turned on or turned off based on the state of the address lines and enable pin.

9.2 Functional Block Diagram

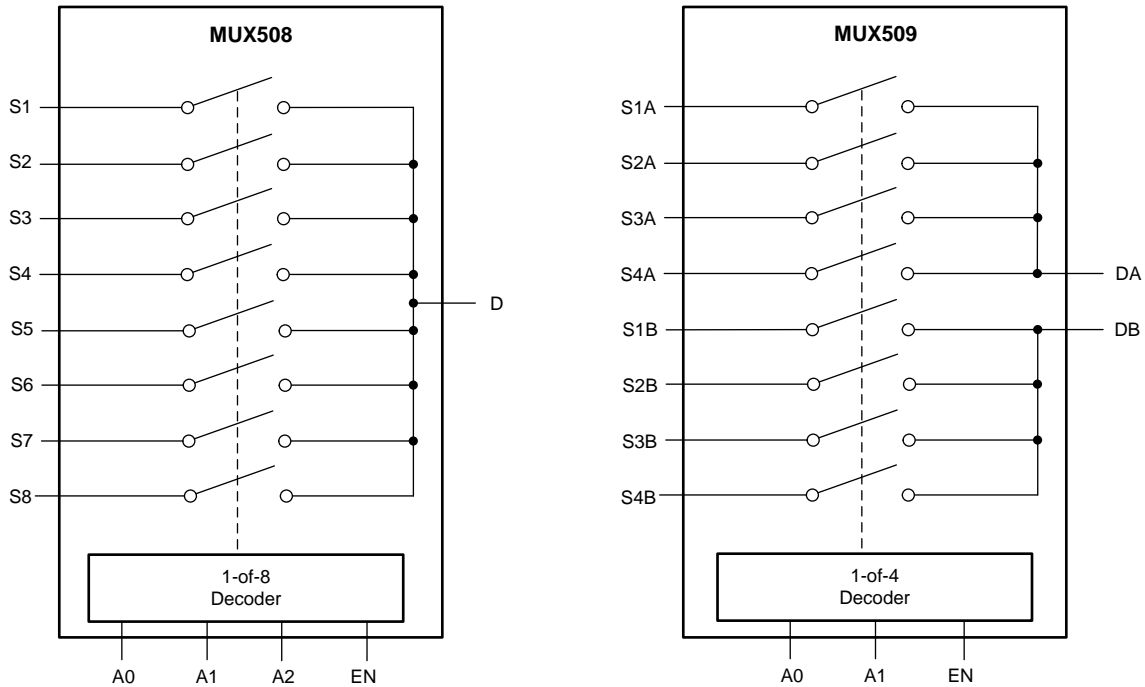

Copyright © 2016, Texas Instruments Incorporated

9.3 Feature Description

9.3.1 Ultralow Leakage Current

The MUX50x provide extremely low on- and off-leakage currents. The MUX50x are capable of switching signals from high source-impedance inputs into a high input-impedance op amp with minimal offset error because of these ultralow leakage currents. Figure 37 shows typical leakage currents of the MUX50x versus temperature.

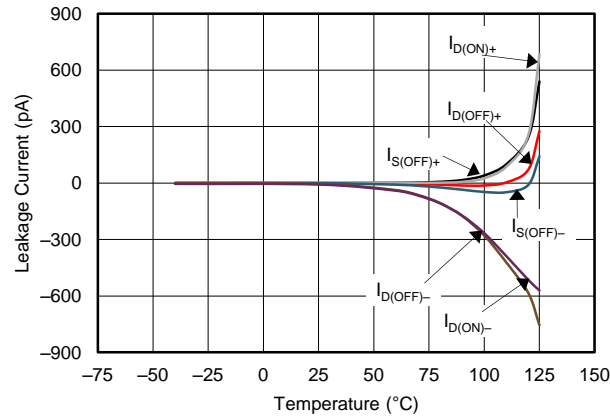

Figure 37. Leakage Current vs Temperature

9.3.2 Ultralow Charge Injection

The MUX50x have a simple transmission gate topology, as shown in Figure 38. Any mismatch in the stray capacitance associated with the NMOS and PMOS transistors creates an output level change whenever the switch is opened or closed.

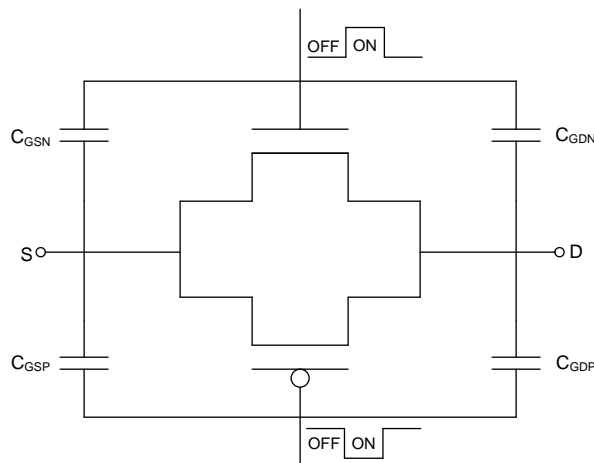

Figure 38. Transmission Gate Topology

Feature Description (continued)

The MUX50x have special charge-injection cancellation circuitry that reduces the source-to-drain charge injection to as low as 0.3 pC at $V_S = 0$ V, and ± 0.6 pC in the full signal range, as shown in Figure 39.

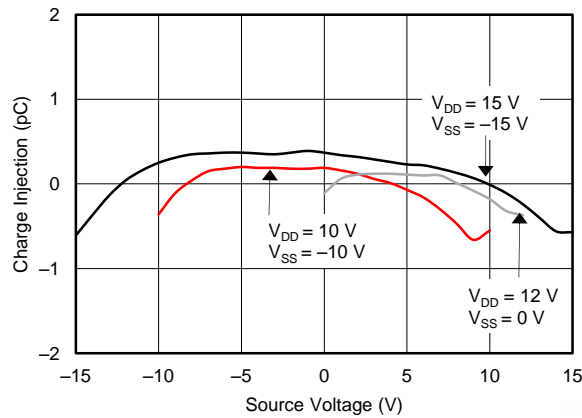

Figure 39. Source-to-Drain Charge Injection vs Source or Drain voltage

The drain-to-source charge injection becomes important when the device is used as a demultiplexer (demux), where D becomes the input and S_x becomes the output. Figure 40 shows the drain-to-source charge injection across the full signal range.

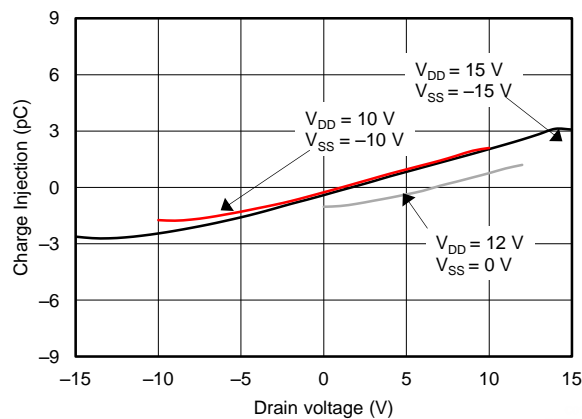

Figure 40. Drain-to-Source Charge Injection vs Source or Drain voltage

9.3.3 Bidirectional Operation

The MUX50x are operable as both a mux or demux. The source (S_x , S_xA , S_xB) and drain (D, DA, DB) pins of the MUX50x are used either as input or output. Each MUX50x channel has very similar characteristics in both directions.

Feature Description (continued)

9.3.4 Rail-to-Rail Operation

A valid analog signal for the MUX50x ranges from V_{SS} to V_{DD} . The input signal to the MUX50x can swing from V_{SS} to V_{DD} without any significant degradation in performance. The on-resistance of the MUX50x varies with input signal, as shown in Figure 41.

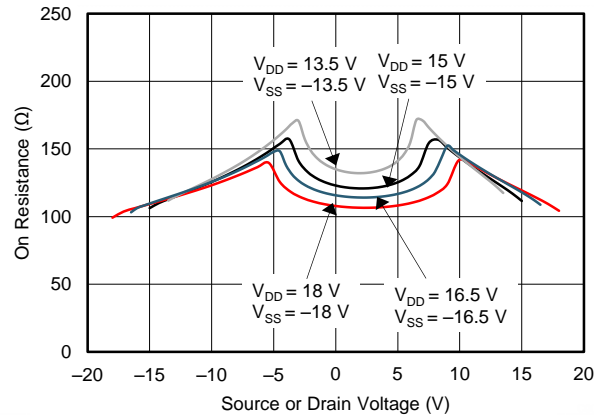

Figure 41. On-Resistance vs Source or Drain Voltage

9.4 Device Functional Modes

When the EN pin of the MUX50x is pulled high, one of the switches is closed based on the state of the address lines. When the EN pin is pulled low, all the switches are in an open state irrespective of the state of the address lines. The EN pin can be connected to V_{DD} (as high as 36 V).

10 Applications and Implementation

NOTE

Information in the following applications sections is not part of the TI component specification, and TI does not warrant its accuracy or completeness. TI's customers are responsible for determining suitability of components for their purposes. Customers should validate and test their design implementation to confirm system functionality.

10.1 Application Information

The MUX50x family offers outstanding input/output leakage currents and ultralow charge injection. These devices operate up to 36 V, and offer true rail-to-rail input and output. The on-capacitance of the MUX50x is very low. These features makes the MUX50x a precision, robust, high-performance analog multiplexer for high-voltage, industrial applications.

10.2 Typical Application

Figure 42 shows a 16-bit, differential, four-channel, multiplexed, data-acquisition system. This example is typical in industrial applications that require low distortion and a high-voltage differential input. The circuit uses the ADS8864, a 16-bit, 400-kSPS successive-approximation-resistor (SAR) analog-to-digital converter (ADC), along with a precision, high-voltage, signal-conditioning front end, and a four-channel differential mux. This application example details the process for optimizing a precision, high-voltage, front-end drive circuit using the MUX509, OPA192 and OPA140 to achieve excellent dynamic performance and linearity with the ADS8864.

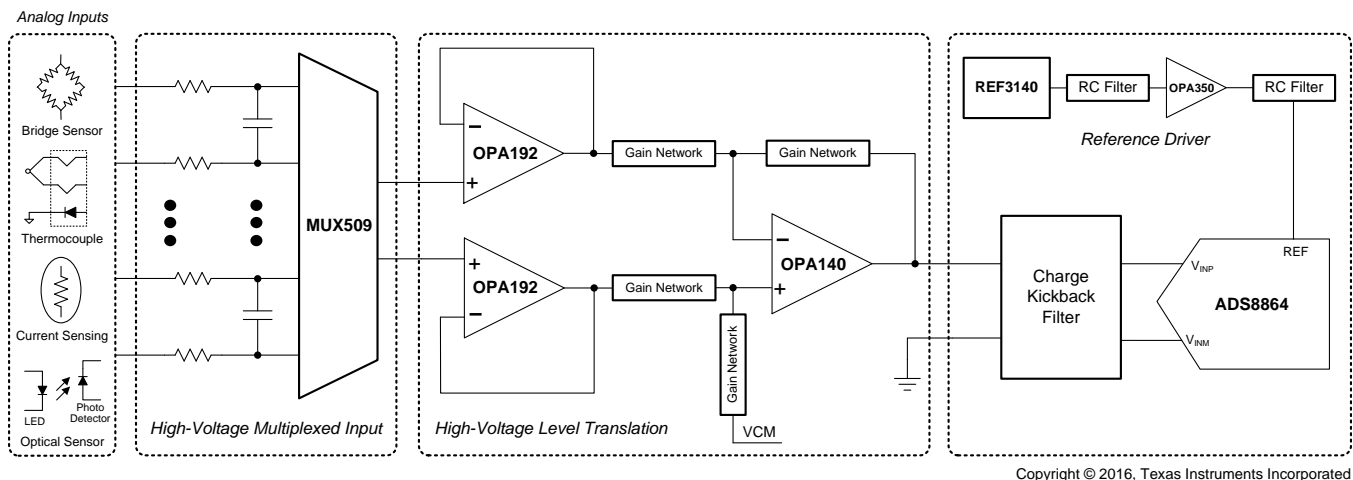

Copyright © 2016, Texas Instruments Incorporated

Figure 42. 16-Bit Precision Multiplexed Data-Acquisition System for High-Voltage Inputs With Lowest Distortion

10.2.1 Design Requirements

The primary objective is to design a ± 20 V, differential, four-channel, multiplexed, data-acquisition system with lowest distortion using the 16-bit ADS8864 at a throughput of 400 kSPS for a 10-kHz, full-scale, pure, sine-wave input. The design requirements for this block design are:

- System supply voltage: ± 15 V
- ADC supply voltage: 3.3 V
- ADC sampling rate: 400 kSPS
- ADC reference voltage (REFP): 4.096 V
- System input signal: A high-voltage differential input signal with a peak amplitude of 20 V and frequency (f_{IN}) of 10 kHz are applied to each differential input of the mux.

Typical Application (continued)

10.2.2 Detailed Design Procedure

The purpose of this precision design is to design an optimal, high-voltage, multiplexed, data-acquisition system for highest system linearity and fast settling. The overall system block diagram is illustrated in [Figure 42](#). The circuit is a multichannel, data-acquisition signal chain consisting of an input low-pass filter, mux, mux output buffer, attenuating SAR ADC driver, and the reference driver. The architecture allows fast sampling of multiple channels using a single ADC, providing a low-cost solution. This design systematically approaches each analog circuit block to achieve a 16-bit settling for a full-scale input stage voltage and linearity for a 10-kHz sinusoidal input signal at each input channel.



For step-by-step design procedure, circuit schematics, bill of materials, PCB files, simulation results, and test results, see [TI Precision Design TIPD151, 16-Bit, 400-kSPS, 4-Channel Multiplexed Data-Acquisition System for High-Voltage Inputs with Lowest Distortion](#).

10.2.3 Application Curve

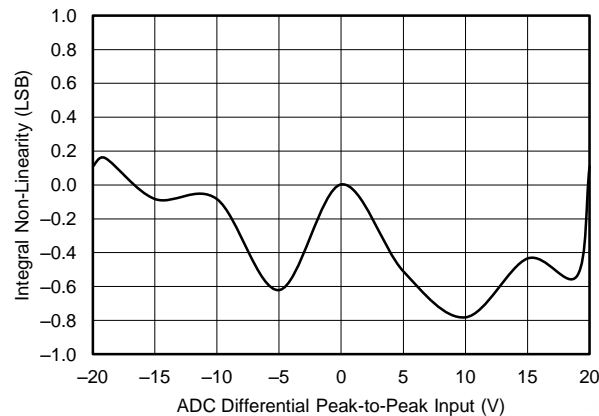

Figure 43. ADC 16-Bit Linearity Error for the Multiplexed Data-Acquisition Block

11 Power-Supply Recommendations

The MUX50x operates across a wide supply range of ± 5 V to ± 18 V (10 V to 36 V in single-supply mode). The MUX508 and MUX509 operate equally well with either dual supplies (± 5 V to ± 18 V), or a single supply (10 V to 36 V). They also perform well with unsymmetric supplies such as $V_{DD} = 12$ V and $V_{SS} = -5$ V. For reliable operation, use a supply decoupling capacitor with a capacitance between 0.1 μ F to 10 μ F at both the VDD and VSS pins to ground.

The on-resistance of the MUX50x varies with supply voltage, as shown in [Figure 44](#).

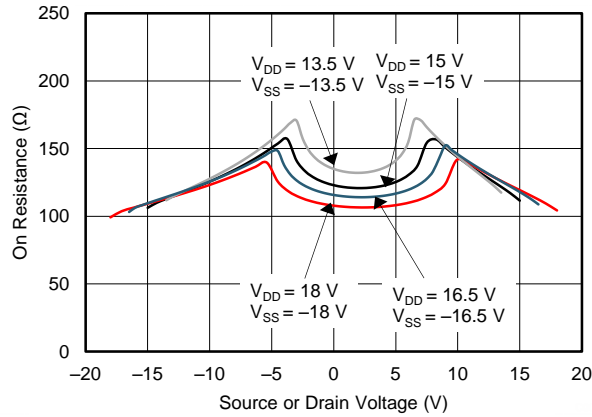

Figure 44. On-Resistance Variation With Supply and Input Voltage

12 Layout

12.1 Layout Guidelines

Figure 45 shows an example of a PCB layout with the MUX508IPW, and Figure 46 shows an example of a PCB layout with MUX509IPW. The guidelines provided in this section are also applicable to the SOIC MUX508ID and MUX509ID package variants as well.

Some key considerations are:

1. Decouple the VDD and VSS pins with a 0.1- μ F capacitor, placed as close to the pin as possible. Make sure that the capacitor voltage rating is sufficient for the V_{DD} and V_{SS} supplies.
2. Keep the input lines as small as possible. For the MUX509 differential signals, make sure the A inputs and B inputs are as symmetric as possible.
3. Use a solid ground plane to help distribute heat and reduce electromagnetic interference (EMI) noise pickup.
4. Do not run sensitive analog traces in parallel with digital traces. Avoid crossing digital and analog traces if possible and only make perpendicular crossings when necessary.

12.2 Layout Example

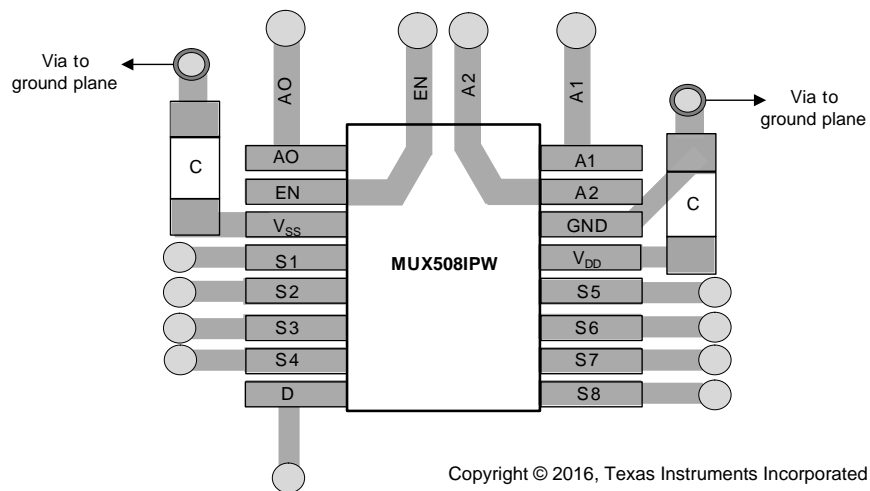

Figure 45. MUX508IPW Layout Example

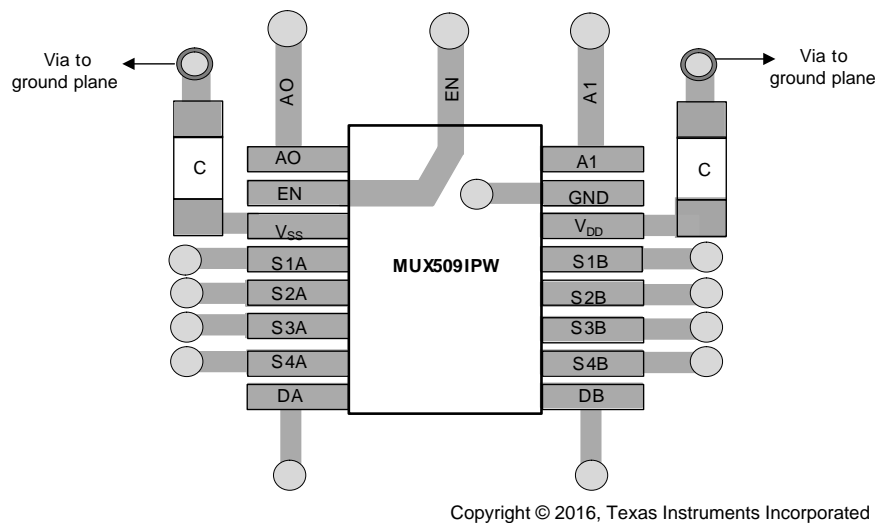

Figure 46. MUX509IPW Layout Example

13 器件和文档支持

13.1 文档支持

13.1.1 相关文档

- 《[ADS866x 支持双极输入范围的 12 位、500kSPS、4 通道和 8 通道单电源 SAR ADC](#)》（文献编号：SBAS492）
- 《[OPAx140 高精度、低噪声、轨到轨输出、11 MHz JFET 运算放大器](#)》（文献编号：SBOS498）
- 《[OPAx192 具有 e-trim™ 的 36V、精密、轨到轨输入/输出、低偏移电压、低输入偏置电流运算放大器](#)》（文献编号：SBOS620）

13.2 相关链接

表 3 列出了快速访问链接。范围包括技术文档、支持与社区资源、工具和软件，以及样片与购买的快速访问。

表 3. 相关链接

部件	产品文件夹	样片与购买	技术文档	工具与软件	支持与社区
MUX508	请单击此处	请单击此处	请单击此处	请单击此处	请单击此处
MUX509	请单击此处	请单击此处	请单击此处	请单击此处	请单击此处

13.3 接收文档更新通知

如需接收文档更新通知，请访问 www.ti.com.cn 网站上的器件产品文件夹。点击右上角的提醒我 (Alert me) 注册后，即可每周定期收到已更改的产品信息。有关更改的详细信息，请查阅已修订文档中包含的修订历史记录。

13.4 社区资源

The following links connect to TI community resources. Linked contents are provided "AS IS" by the respective contributors. They do not constitute TI specifications and do not necessarily reflect TI's views; see TI's [Terms of Use](#).

TI E2E™ Online Community *TI's Engineer-to-Engineer (E2E) Community*. Created to foster collaboration among engineers. At e2e.ti.com, you can ask questions, share knowledge, explore ideas and help solve problems with fellow engineers.

Design Support *TI's Design Support* Quickly find helpful E2E forums along with design support tools and contact information for technical support.

13.5 商标

E2E is a trademark of Texas Instruments.
All other trademarks are the property of their respective owners.

13.6 静电放电警告



ESD 可能会损坏该集成电路。德州仪器 (TI) 建议通过适当的预防措施处理所有集成电路。如果不遵守正确的处理措施和安装程序，可能会损坏集成电路。

ESD 的损坏小至导致微小的性能降级，大至整个器件故障。精密的集成电路可能更容易受到损坏，这是因为非常细微的参数更改都可能会导致器件与其发布的规格不相符。

13.7 Glossary

[SLYZ022](#) — *TI Glossary*.

This glossary lists and explains terms, acronyms, and definitions.

14 机械、封装和可订购信息

以下页中包括机械、封装和可订购信息。这些信息是针对指定器件可提供的最新数据。这些数据会在无通知且不对本文档进行修订的情况下发生改变。欲获得该数据表的浏览器版本，请查阅左侧的导航栏。

PACKAGING INFORMATION

Orderable Device	Status (1)	Package Type	Package Drawing	Pins	Package Qty	Eco Plan (2)	Lead finish/ Ball material (6)	MSL Peak Temp (3)	Op Temp (°C)	Device Marking (4/5)	Samples
MUX508ID	ACTIVE	SOIC	D	16	40	RoHS & Green	SN	Level-2-260C-1 YEAR	-40 to 125	M36508D	Samples
MUX508IDR	ACTIVE	SOIC	D	16	2500	RoHS & Green	SN	Level-2-260C-1 YEAR	-40 to 125	M36508D	Samples
MUX508IPW	ACTIVE	TSSOP	PW	16	90	RoHS & Green	NIPDAU	Level-2-260C-1 YEAR	-40 to 125	MUX508B	Samples
MUX508IPWR	ACTIVE	TSSOP	PW	16	2000	RoHS & Green	NIPDAU	Level-2-260C-1 YEAR	-40 to 125	MUX508B	Samples
MUX509ID	ACTIVE	SOIC	D	16	40	RoHS & Green	SN	Level-2-260C-1 YEAR	-40 to 125	M36509D	Samples
MUX509IDR	ACTIVE	SOIC	D	16	2500	RoHS & Green	SN	Level-2-260C-1 YEAR	-40 to 125	M36509D	Samples
MUX509IPW	ACTIVE	TSSOP	PW	16	90	RoHS & Green	NIPDAU	Level-2-260C-1 YEAR	-40 to 125	MUX509C	Samples
MUX509IPWR	ACTIVE	TSSOP	PW	16	2000	RoHS & Green	NIPDAU	Level-2-260C-1 YEAR	-40 to 125	MUX509C	Samples

(1) The marketing status values are defined as follows:

ACTIVE: Product device recommended for new designs.

LIFEBUY: TI has announced that the device will be discontinued, and a lifetime-buy period is in effect.

NRND: Not recommended for new designs. Device is in production to support existing customers, but TI does not recommend using this part in a new design.

PREVIEW: Device has been announced but is not in production. Samples may or may not be available.

OBSELETE: TI has discontinued the production of the device.

(2) **RoHS:** TI defines "RoHS" to mean semiconductor products that are compliant with the current EU RoHS requirements for all 10 RoHS substances, including the requirement that RoHS substance do not exceed 0.1% by weight in homogeneous materials. Where designed to be soldered at high temperatures, "RoHS" products are suitable for use in specified lead-free processes. TI may reference these types of products as "Pb-Free".

RoHS Exempt: TI defines "RoHS Exempt" to mean products that contain lead but are compliant with EU RoHS pursuant to a specific EU RoHS exemption.

Green: TI defines "Green" to mean the content of Chlorine (Cl) and Bromine (Br) based flame retardants meet JS709B low halogen requirements of <=1000ppm threshold. Antimony trioxide based flame retardants must also meet the <=1000ppm threshold requirement.

(3) MSL, Peak Temp. - The Moisture Sensitivity Level rating according to the JEDEC industry standard classifications, and peak solder temperature.

(4) There may be additional marking, which relates to the logo, the lot trace code information, or the environmental category on the device.

(5) Multiple Device Markings will be inside parentheses. Only one Device Marking contained in parentheses and separated by a "~" will appear on a device. If a line is indented then it is a continuation of the previous line and the two combined represent the entire Device Marking for that device.

⁽⁶⁾ Lead finish/Ball material - Orderable Devices may have multiple material finish options. Finish options are separated by a vertical ruled line. Lead finish/Ball material values may wrap to two lines if the finish value exceeds the maximum column width.

Important Information and Disclaimer:The information provided on this page represents TI's knowledge and belief as of the date that it is provided. TI bases its knowledge and belief on information provided by third parties, and makes no representation or warranty as to the accuracy of such information. Efforts are underway to better integrate information from third parties. TI has taken and continues to take reasonable steps to provide representative and accurate information but may not have conducted destructive testing or chemical analysis on incoming materials and chemicals. TI and TI suppliers consider certain information to be proprietary, and thus CAS numbers and other limited information may not be available for release.

In no event shall TI's liability arising out of such information exceed the total purchase price of the TI part(s) at issue in this document sold by TI to Customer on an annual basis.

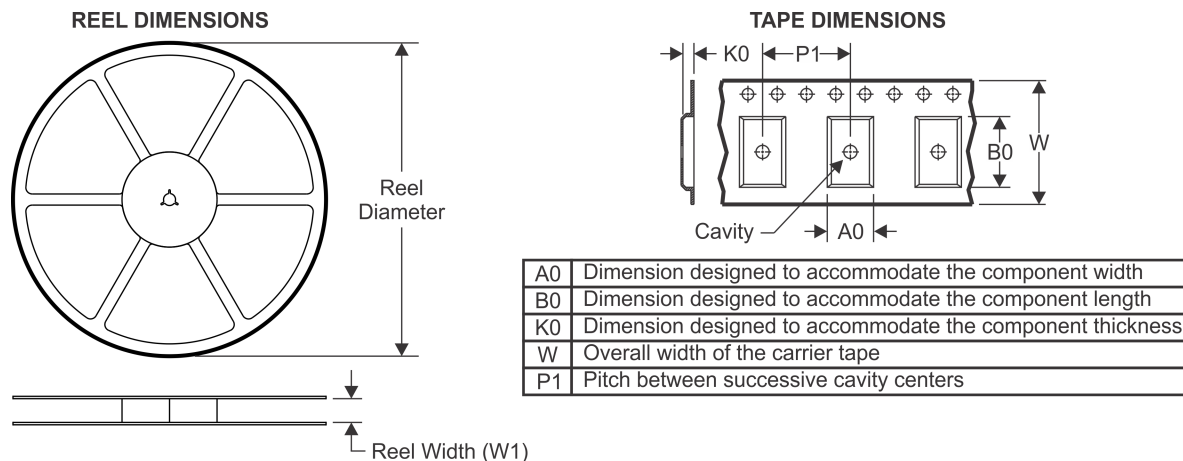
TAPE AND REEL INFORMATION

QUADRANT ASSIGNMENTS FOR PIN 1 ORIENTATION IN TAPE



*All dimensions are nominal

Device	Package Type	Package Drawing	Pins	SPQ	Reel Diameter (mm)	Reel Width W1 (mm)	A0 (mm)	B0 (mm)	K0 (mm)	P1 (mm)	W (mm)	Pin1 Quadrant
MUX508IDR	SOIC	D	16	2500	330.0	16.8	6.5	10.3	2.1	8.0	16.0	Q1
MUX508IPWR	TSSOP	PW	16	2000	330.0	12.4	6.9	5.6	1.6	8.0	12.0	Q1
MUX509IDR	SOIC	D	16	2500	330.0	16.8	6.5	10.3	2.1	8.0	16.0	Q1
MUX509IPWR	TSSOP	PW	16	2000	330.0	12.4	6.9	5.6	1.6	8.0	12.0	Q1

TAPE AND REEL BOX DIMENSIONS

*All dimensions are nominal

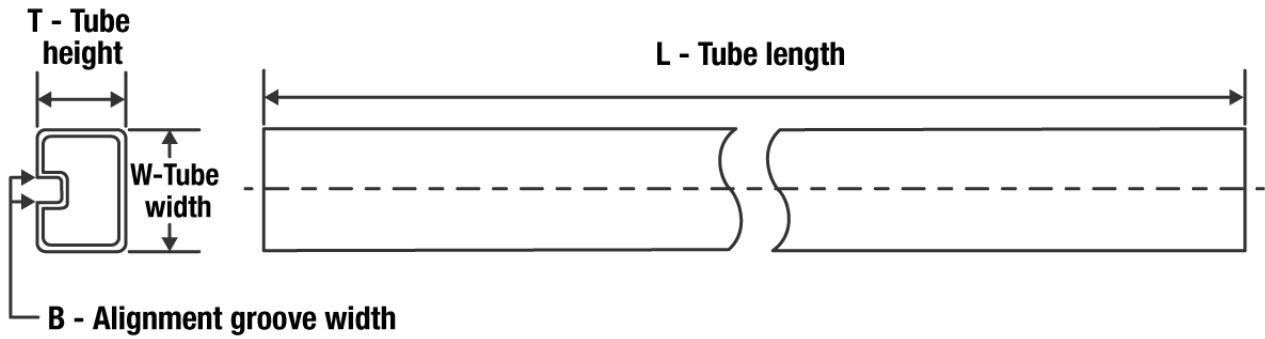
Device	Package Type	Package Drawing	Pins	SPQ	Length (mm)	Width (mm)	Height (mm)
MUX508IDR	SOIC	D	16	2500	366.0	364.0	50.0
MUX508IPWR	TSSOP	PW	16	2000	853.0	449.0	35.0
MUX509IDR	SOIC	D	16	2500	366.0	364.0	50.0
MUX509IPWR	TSSOP	PW	16	2000	853.0	449.0	35.0

TUBE

*All dimensions are nominal

Device	Package Name	Package Type	Pins	SPQ	L (mm)	W (mm)	T (μm)	B (mm)
MUX508ID	D	SOIC	16	40	517	7.87	635	4.25
MUX508IPW	PW	TSSOP	16	90	530	10.2	3600	3.5
MUX509ID	D	SOIC	16	40	517	7.87	635	4.25
MUX509IPW	PW	TSSOP	16	90	530	10.2	3600	3.5

D (R-PDSO-G16)

PLASTIC SMALL OUTLINE



- NOTES:
- A. All linear dimensions are in inches (millimeters).
 - B. This drawing is subject to change without notice.
 - C. Body length does not include mold flash, protrusions, or gate burrs. Mold flash, protrusions, or gate burrs shall not exceed 0.006 (0,15) each side.
 - D. Body width does not include interlead flash. Interlead flash shall not exceed 0.017 (0,43) each side.
 - E. Reference JEDEC MS-012 variation AC.

D (R-PDSO-G16)

PLASTIC SMALL OUTLINE

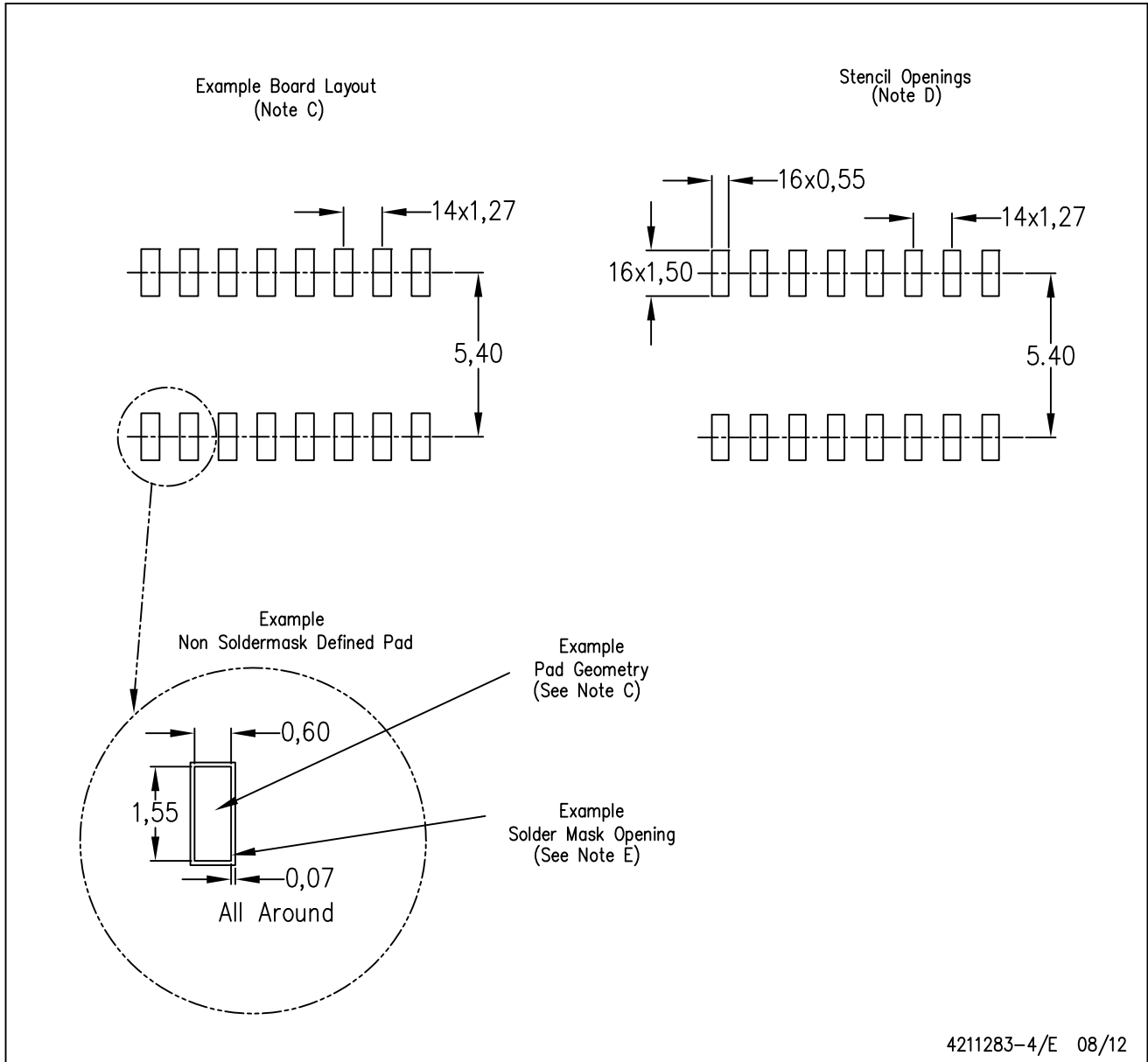

- NOTES:
- All linear dimensions are in millimeters.
 - This drawing is subject to change without notice.
 - Publication IPC-7351 is recommended for alternate designs.
 - Laser cutting apertures with trapezoidal walls and also rounding corners will offer better paste release. Customers should contact their board assembly site for stencil design recommendations. Refer to IPC-7525 for other stencil recommendations.
 - Customers should contact their board fabrication site for solder mask tolerances between and around signal pads.



4220204/A 02/2017

NOTES:

1. All linear dimensions are in millimeters. Any dimensions in parenthesis are for reference only. Dimensioning and tolerancing per ASME Y14.5M.
2. This drawing is subject to change without notice.
3. This dimension does not include mold flash, protrusions, or gate burrs. Mold flash, protrusions, or gate burrs shall not exceed 0.15 mm per side.
4. This dimension does not include interlead flash. Interlead flash shall not exceed 0.25 mm per side.
5. Reference JEDEC registration MO-153.

EXAMPLE BOARD LAYOUT

PW0016A

TSSOP - 1.2 mm max height

SMALL OUTLINE PACKAGE



LAND PATTERN EXAMPLE
EXPOSED METAL SHOWN
SCALE: 10X



SOLDER MASK DETAILS

4220204/A 02/2017

NOTES: (continued)

- 6. Publication IPC-7351 may have alternate designs.
- 7. Solder mask tolerances between and around signal pads can vary based on board fabrication site.

EXAMPLE STENCIL DESIGN

PW0016A

TSSOP - 1.2 mm max height

SMALL OUTLINE PACKAGE

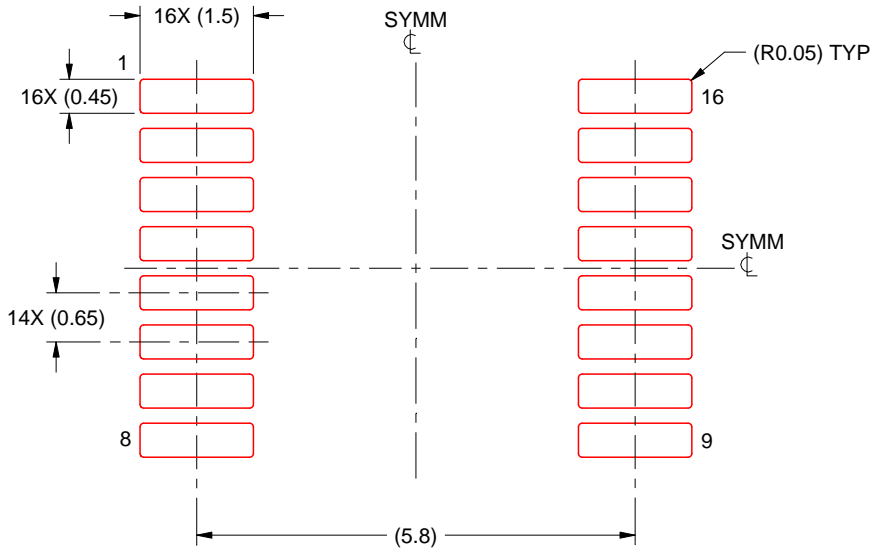

SOLDER PASTE EXAMPLE
BASED ON 0.125 mm THICK STENCIL
SCALE: 10X

4220204/A 02/2017

NOTES: (continued)

8. Laser cutting apertures with trapezoidal walls and rounded corners may offer better paste release. IPC-7525 may have alternate design recommendations.
9. Board assembly site may have different recommendations for stencil design.

重要声明和免责声明

TI“按原样”提供技术和可靠性数据（包括数据表）、设计资源（包括参考设计）、应用或其他设计建议、网络工具、安全信息和其他资源，不保证没有瑕疵且不做任何明示或暗示的担保，包括但不限于对适销性、某特定用途方面的适用性或不侵犯任何第三方知识产权的暗示担保。

这些资源可供使用 TI 产品进行设计的熟练开发人员使用。您将自行承担以下全部责任：(1) 针对您的应用选择合适的 TI 产品，(2) 设计、验证并测试您的应用，(3) 确保您的应用满足相应标准以及任何其他功能安全、信息安全、监管或其他要求。

这些资源如有变更，恕不另行通知。TI 授权您仅可将这些资源用于研发本资源所述的 TI 产品的应用。严禁对这些资源进行其他复制或展示。您无权使用任何其他 TI 知识产权或任何第三方知识产权。您应全额赔偿因在这些资源的使用中对 TI 及其代表造成的任何索赔、损害、成本、损失和债务，TI 对此概不负责。

TI 提供的产品受 [TI 的销售条款](#) 或 [ti.com](#) 上其他适用条款/TI 产品随附的其他适用条款的约束。TI 提供这些资源并不会扩展或以其他方式更改 TI 针对 TI 产品发布的适用的担保或担保免责声明。

TI 反对并拒绝您可能提出的任何其他或不同的条款。

邮寄地址：Texas Instruments, Post Office Box 655303, Dallas, Texas 75265

Copyright © 2022，德州仪器 (TI) 公司