

TPS92830-Q1 3 通道大电流线性 LED 控制器

1 特性

- 符合 AEC-Q100 标准
 - 器件温度等级 1: 环境运行温度范围为 -40°C 至 125°C
 - 器件人体放电模型 (HBM) 静电防护 (ESD) 分类等级 H2
 - 器件组件充电模型 (CDM) ESD 分类等级 C4B
- 4.5V 至 40V 的宽电压输入范围
- 3 通道高侧电流驱动和检测
 - 通道独立的电流设置
 - 通道独立的 PWM 输入
 - 通过 PWM 输入和电源实现 PWM 调光
 - 针对 EMC 优化的压摆率
- 高精度 LED 驱动
 - 采用外部 N 沟道 MOSFET 的精密电流调节 (2.5% 容差)
 - 具有非板载 Bin 电阻支持的 20:1 模拟调光配置
 - 具有全占空比屏蔽的精密 PWM 发生器 (2% 容差)
 - 用于同步的开漏 PWM 输出
- 保护和诊断
 - 用于外部 MOSFET 热保护的可调节输出电流降额
 - 具有自动恢复功能的 LED 灯串开路或短路诊断
 - 针对低电压运行支持诊断并具有可调节阈值
 - 多达 15 个器件的故障总线, 可配置为连带失效或仅失效的通道关闭
 - 故障模式下具有较低的静态电流 (每个器件小于 0.75mA)
- 工作结温范围: -40°C 至 150°C
- TSSOP 28 封装 (PW)

2 应用

- 后灯 – 尾灯和制动灯、后转向灯、雾灯、倒车灯
- 前灯 – 位置灯、日间行车灯、前转向灯、近光灯

3 说明

在实现更佳的灯光均匀性的趋势下, 高电流 LED 通常用于汽车前灯和后灯 (配备灯光扩散器和导光板)。同时, 为了满足严格的 EMC 和可靠性要求, 线性 LED 驱动器广泛用于汽车应用。不过, 通过集成功率晶体管为线性 LED 驱动器提供高电流是一项挑战。

TPS92830-Q1 器件是一款先进的汽车级高侧恒定电流线性 LED 控制器, 通过使用外部 N 沟道 MOSFET 提供高电流。该器件具有一整套用于汽车应用的功能, 并与各种 N 沟道 MOSFET 兼容。

TPS92830-Q1 器件的每个通道可以通过感应电阻器值独立设置通道电流。内部精密恒定电流调节环路通过感应电阻器上的电压感应通道电流, 并相应地控制 N 沟道 MOSFET 的栅极电压。该器件还集成了一个两级电荷泵, 用于低压降运行。电荷泵电压足够高, 可以支持各种 N 沟道 MOSFET。PWM 调光允许使用多个

器件信息(1)

器件型号	封装	封装尺寸 (标称值)
TPS92830-Q1	TSSOP (28)	9.70mm x 4.40mm

(1) 要了解所有可用封装, 请见数据表末尾的可订购产品附录。

简化原理图

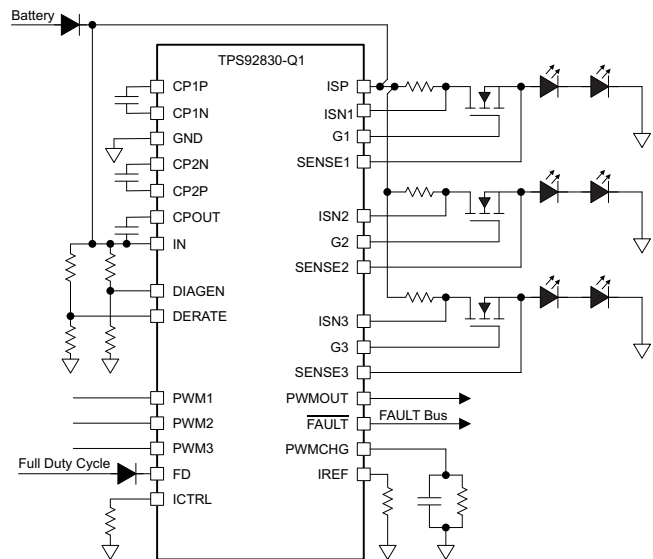

目录

1 特性	1	8.2 Functional Block Diagram	14
2 应用	1	8.3 Feature Description	15
3 说明	1	8.4 Device Functional Modes	29
4 修订历史记录	2	9 Application and Implementation	30
5 说明 (续)	4	9.1 Application Information	30
6 Pin Configuration and Functions	4	9.2 Typical Applications	30
7 Specifications	6	10 Layout	36
7.1 Absolute Maximum Ratings	6	10.1 Layout Guidelines	36
7.2 ESD Ratings	6	10.2 Layout Example	36
7.3 Recommended Operating Conditions	6	11 器件和文档支持	37
7.4 Thermal Information	7	11.1 接收文档更新通知	37
7.5 Electrical Characteristics	7	11.2 社区资源	37
7.6 Timing Requirements	9	11.3 商标	37
7.7 Typical Characteristics	11	11.4 静电放电警告	37
8 Detailed Description	14	11.5 Glossary	37
8.1 Overview	14	12 机械、封装和可订购信息	37

4 修订历史记录

注：之前版本的页码可能与当前版本有所不同。

Changes from Revision A (October 2017) to Revision B

Page

• Changed timing specification for PWM duty cycle	9
---	---

Changes from Original (July 2017) to Revision A

Page

• 在特性 部分中更改了电流调节和 PWM 发生器的容差	1
• Changed values for several parameters throughout the <i>Electrical Characteristics</i> table	7
• Changed parameter definitions for $I_{(DRV_source)}$ and $I_{(DRV_sink)}$ in the <i>Electrical Characteristics</i> table	7
• Changed parameter symbols for analog dimming accuracy in the <i>Electrical Characteristics</i> table	8
• Changed parameter descriptions for $V_{(OPEN_th_rising)}$, $V_{(OPEN_th_falling)}$,	8
• Changed parameter descriptions for $t_{(SG_retry_OFF)}$ and $t_{(OPEN_retry_OFF)}$ in the <i>Timing Requirements</i> table	9
• Added a condition for <i>Typical Characteristic</i> 图 6	11
• Deleted a condition from <i>Typical Characteristic</i> 图 8	12
• Deleted a <i>Fast Power Down and Slow Power Up</i> typical characteristic graph	12
• Added a <i>Fast Power Down and Slow Power Up</i> typical characteristic graph	13
• Added a condition for <i>Typical Characteristic</i> 图 17	13
• Added a condition for <i>Typical Characteristic</i> 图 18	13
• Changed <i>heat dissipation</i> to <i>current distribution</i> in Parallel MOSFET Driving	17
• Deleted a sentence from the PWM Dimming by Input section	18
• Added resistor and capacitor reference designators	19
• Deleted percentage values for $V_{(ICTRL_LIN_BOT)}$ and $V_{(ICTRL_LIN_TOP)}$ in the Analog Dimming Topology section	21
• Changed $V_{(SG_th_rising)}$ and $V_{(SG_th_falling)}$ with each other in the LED Short-to-GND Detection section	25
• Changed symbol of short-to-ground retry current to $I_{(Retry_short)}$	26
• Changed symbol of LED-open retry current to $I_{(Retry_open)}$ in the LED Open-Circuit Auto Retry section	26
• Changed some FAULT TYPE names in 表 4	29
• Updated application schematic.	30
• Changed the value of R8 from 75 kΩ to 76 kΩ for the PWM threshold setting	31
• Changed the equation for calculating $K_{(RES_DiagEn)}$	31

- Changed the values of R13 and R6 for 31
- Changed the equation for calculating $K_{(RES_DERATE)}$ 31
- Changed component values in the PWM equations of the *Detailed Design Procedure* 33
- Added an application curve 34
- Added text in the *Layout Guidelines* for keeping LED ground separate from device ground 36

5 说明 (续)

源以实现灵活性 - 内部 PWM 发生器、外部 PWM 输入或电源调光。各种专为汽车应用设计的诊断和保护可帮助提高系统稳健性和易用性。连带失效故障总线支持 TPS92830-Q1 与 TPS92630-Q1、TPS92638-Q1 和 TPS9261x-Q1 系列一同运行，以满足各种故障处理要求。

6 Pin Configuration and Functions

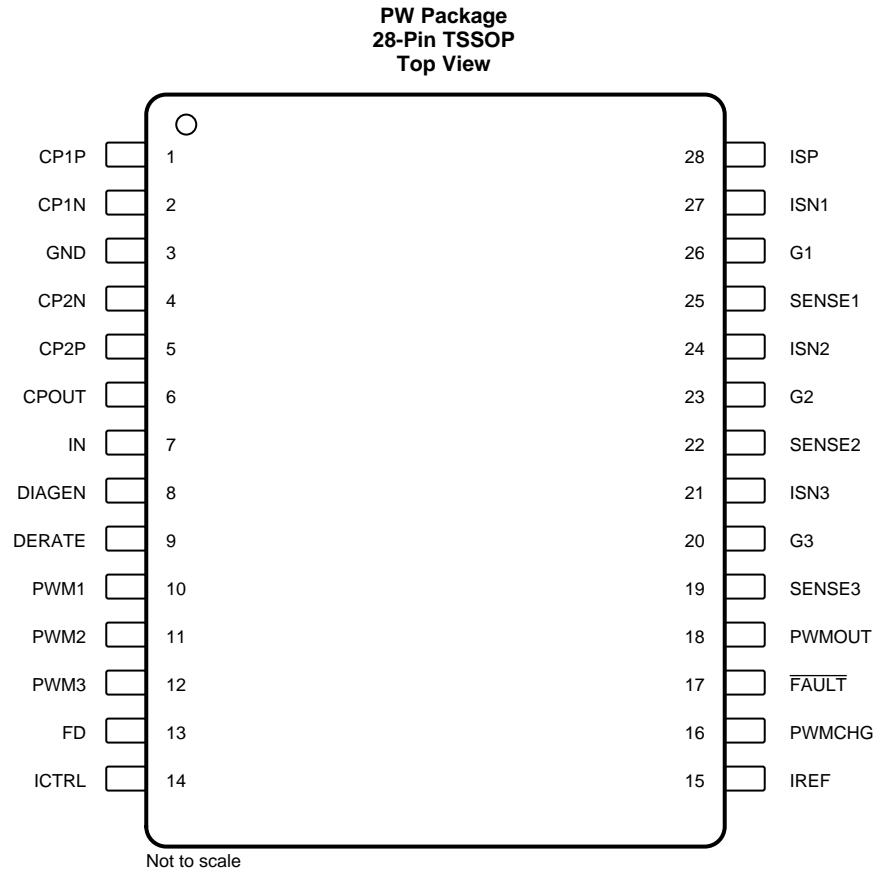

Pin Functions

PIN		I/O	DESCRIPTION
NAME	NO.		
CP1N	2	O	Charge pump first-stage flying capacitor negative output, charge pump to provide gate-drive voltage for external MOSFET. Connect a 10-nF flying capacitor between CP1P and CP1N.
CP1P	1	O	Charge pump first-stage flying capacitor positive output
CP2N	4	O	Charge pump second-stage flying capacitor negative output. Connect a 10-nF flying capacitor between CP2P and CP2N.
CP2P	5	O	Charge pump second-stage flying capacitor positive output
CPOUT	6	O	Charge-pump output voltage. Connect a 150-nF storage capacitor between CPOUT and IN.
DERATE	9	I	Voltage input for current derating. Connect to GND to disable the derate feature.
DIAGEN	8	I	Input pin with comparator to enable diagnostics to avoid false open-fault diagnostics when the device works in low-dropout mode. Use a resistor divider to set a threshold according to the LED forward voltage.
$\overline{\text{FAULT}}$	17	I/O	Fault bus pin to support one-fails-all-fail feature. Float: one-fails-all-fail; strong pullup: only-fails-off
FD	13	I	Full duty-cycle input, HIGH: 100% PWM; LOW: using external resistor-capacitor network to set PWM duty cycle

Pin Functions (continued)

PIN		I/O	DESCRIPTION
NAME	NO.		
G1	26	O	Channel 1 gate driver output, connect to CH 1 N-channel MOSFET gate
G2	23	O	Channel 2 gate driver output, connect to CH 2 N-channel MOSFET gate
G3	20	O	Channel 3 gate driver output, connect to CH 3 N-channel MOSFET gate
GND	3	—	GND
ICTRL	14	I	Analog dimming input, modulates the regulation voltage across the current-sense resistor. Apply a voltage source or connect a resistor between ICTRL and GND to set the analog dimming ratio.
IN	7	I	Power supply for the device. LED current only flows from the external MOSFET to the LED.
ISN1	27	I	Channel 1 current-sense negative input. Connect a current-sense resistor between ISP and ISN1 to set the CH 1 current.
ISN2	24	I	Channel 2 current-sense negative input. Connect a current-sense resistor between ISP and ISN2 to set the CH 2 current.
ISN3	21	I	Channel 3 current-sense negative input. Connect a current-sense resistor between ISP and ISN3 to set the CH 3 current.
IREF	15	O	Internal current reference. Connect an 8-k Ω resistor between IREF and GND,
ISP	28	I	Channel current-sense positive input. Kelvin-sense to LED sense-resistor positive node.
PWM1	10	I	Channel 1 PWM input
PWM2	11	I	Channel 2 PWM input
PWM3	12	I	Channel 3 PWM input
PWMCHG	16	I/O	On-chip PWM generator pin for external R-C. Connect a resistor and a capacitor between PWMCHG and GND to set the PWM duty cycle and frequency.
PWMOUT	18	O	High-voltage PWM open-drain output. Connect a 10-k Ω resistor between IN and PWMOUT
SENSE1	25	I/O	Channel 1 diagnostics pin. Connect to the CH 1 MOSFET source terminal
SENSE2	22	I/O	Channel 2 diagnostics pin. Connect to the CH 2 MOSFET source terminal
SENSE3	19	I/O	Channel 3 diagnostics pin. Connect to the CH 3 MOSFET source terminal

7 Specifications

7.1 Absolute Maximum Ratings

 over operating junction temperature range $T_J = -40^{\circ}\text{C}$ to 150°C (unless otherwise noted)⁽¹⁾

		MIN	MAX	UNIT
Supply voltage	IN ⁽²⁾	-0.3	45 ⁽³⁾	V
Input voltage	DERATE, DIAGEN, FD, ICTRL, ISN1, ISN2, ISN3, ISP, PWM1, PWM2, PWM3, PWMOUT, SENSE1, SENSE2, SENSE3 ⁽²⁾	-0.3	$V_{(IN)} + 0.3$	V
Output voltage	CP1P, CP2P, CPOUT, G1, G2, G3 ⁽²⁾	-0.3	$V_{(IN)} + 10$	V
Current-sense voltage	$V_{(ISP)} - V_{(ISNx)}$	-0.3	1	V
Gate-source voltage	$V_{(Gx)} - V_{(SENSEx)}$	-1	12	V
I/O	FAULT ⁽²⁾	-0.3	22	V
	CP1N, CP2N, IREF, PWMCHG ⁽²⁾	-0.3	6	V
Storage temperature, T_{stg}		-65	150	$^{\circ}\text{C}$
Junction temperature, T_J		-40	150	$^{\circ}\text{C}$

- (1) Stresses beyond those listed under *Absolute Maximum Ratings* may cause permanent damage to the device. These are stress ratings only, which do not imply functional operation of the device at these or any other conditions beyond those indicated under *Recommended Operating Conditions*. Exposure to absolute-maximum-rated conditions for extended periods may affect device reliability.
- (2) All voltages are with respect to GND.
- (3) Absolute maximum voltage 45 V for 200 ms.

7.2 ESD Ratings

		VALUE	UNIT	
$V_{(ESD)}$ Electrostatic discharge	Human-body model (HBM), per AEC Q100-002 ⁽¹⁾	± 2000	V	
	Charged-device model (CDM), per AEC Q100-011	Corner pins (CP1P, ICTRL, IREF, ISP)		± 750
		Other pins		± 500

- (1) AEC Q100-002 indicates that HBM stressing shall be in accordance with the ANSI/ESDA/JEDEC JS-001 specification.

7.3 Recommended Operating Conditions

 over operating junction temperature range $T_J = -40^{\circ}\text{C}$ to 150°C (unless otherwise noted)

		MIN	MAX	UNIT
Device supply voltage	IN	4.5	40	V
Sense voltage	ISP	0	$V_{(IN)}$	V
PWM inputs	PWMx	0	$V_{(IN)}$	V
Diagnostics enable pin	DIAGEN	0	$V_{(IN)}$	V
Current-sense voltage	$V_{(ISP)} - V_{(ISNx)}$	0	1	V
Fault bus	FAULT	0	20	V
PWM open-drain output	PWMOUT	0	$V_{(IN)}$	V
Analog dimming input	ICTRL	0	$V_{(IN)}$	V
Current derating input	DERATE	0	$V_{(IN)}$	V
Full duty-cycle input	FD	0	$V_{(IN)}$	V

7.4 Thermal Information

THERMAL METRIC ⁽¹⁾		TPS92830-Q1	UNIT
		PW (TSSOP)	
		28 PINS	
R _{θJA}	Junction-to-ambient thermal resistance	79.4	°C/W
R _{θJC(top)}	Junction-to-case (top) thermal resistance	20.1	°C/W
R _{θJB}	Junction-to-board thermal resistance	37.4	°C/W
ψ _{JT}	Junction-to-top characterization parameter	0.5	°C/W
ψ _{JB}	Junction-to-board characterization parameter	36.9	°C/W
R _{θJC(bot)}	Junction-to-case (bottom) thermal resistance	N/A	°C/W

(1) For more information about traditional and new thermal metrics, see [Semiconductor and IC Package Thermal Metrics](#).

7.5 Electrical Characteristics

V_{IN} = 5 V to 40 V, V_{ICTRL} = 3 V, V_{DERATE} = 0 V, T_J = –40°C to 150°C,⁽¹⁾ (unless otherwise noted)

PARAMETER		TEST CONDITIONS	MIN	TYP	MAX	UNIT
BIAS						
V _(POR_rising)	Supply voltage POR, rising threshold				4.5	V
I _(Quiescent)	Device standby current	PWMx = HIGH, FD = HIGH		3.5		mA
I _(FAULT)	Device current in fault mode	PWMx = HIGH, $\overline{\text{FAULT}}$ = LOW		0.5	0.75	mA
I _(IREF)	Reference current	R _(IREF) = 8 kΩ		99		μA
C _(IREF)	IREF loading capacitance	R _(IREF) = 8 kΩ	0		4.3	nF
CHARGE PUMP						
V _(cp_drv)	Charge-pump operating voltage		6.1	8.5	10	V
f _(cp_sw)	Charge-pump switching frequency			2.65		MHz
C _(cp_flying)	Charge-pump flying capacitor			10		nF
C _(cp_storage)	Charge-pump storage capacitor			150		nF
HIGH-PRECISION LOGIC INPUTS (DIAGEN, PWMx, FD)						
V _{IL(DIAGEN)}	Input logic-low voltage, DIAGEN		1.105	1.145	1.185	V
V _{IH(DIAGEN)}	Input logic-high voltage, DIAGEN		1.193	1.224	1.255	V
V _{IL(PWMx)}	Input logic-low voltage, PWMx		1.094	1.128	1.161	V
V _{IH(PWMx)}	Input logic-high voltage, PWMx		1.176	1.212	1.248	V
V _{IL(FD)}	Input logic-low voltage, FD		1.105	1.133	1.161	V
V _{IH(FD)}	Input logic-high voltage, FD		1.186	1.216	1.246	V
CONSTANT-CURRENT EXTERNAL N-CHANNEL MOSFET DRIVER						
V _(CS_REG_FULL)	Current-sense-resistor regulation voltage	V _(ICTRL) = 3 V, V _(DERATE) = 0 V		295		mV
ΔV _{(CS)⁽²⁾⁽³⁾}	Current-sense-resistor regulation-voltage accuracy	V _(ICTRL) = 3 V, V _(DERATE) = 0 V, channel accuracy	–1.5%		1.5%	
		V _(ICTRL) = 3 V, V _(DERATE) = 0 V, device accuracy	–2.5%		2.5%	
I _(DRV_source)	Gate-driver current-source capability at Gx		190	230	270	μA

(1) External N-channel MOSFET C_{iss} = 200 pF, C_{oss} = 70 pF, at V_{DS} = 25 Vdc, V_{GS} = 0 Vdc, f = 1 MHz, V_{th} = 4 V, compensation capacitor C_{gs} = 4 nF

$$\Delta V_{(CS_Channel_CHx)} = 1 - \frac{3 \times V_{(CS_REG_x)}}{\left(V_{(CS_REG_1)} + V_{(CS_REG_2)} + V_{(CS_REG_3)} \right)}, x = 1, 2, 3$$

(2)

$$\Delta V_{(CS_Device_CHx)} = 1 - \frac{V_{(CS_REG_x)}}{0.295}, x = 1, 2, 3$$

(3)

Electrical Characteristics (continued)
 $V_{IN} = 5\text{ V to }40\text{ V}$, $V_{ICTRL} = 3\text{ V}$, $V_{DERATE} = 0\text{ V}$, $T_J = -40^\circ\text{C to }150^\circ\text{C}$,⁽¹⁾ (unless otherwise noted)

PARAMETER		TEST CONDITIONS	MIN	TYP	MAX	UNIT
$I_{(DRV_sink)}$	Gate-driver current-sink capability at Gx		190	230	270	μA
$V_{(GS_clamp_neg)}$	Gate-source negative clamp voltage		-0.9	-0.7	-0.5	V
$V_{(GS_clamp_pos)}$	Gate-source positive clamp voltage		9.8	10.4	11.3	V
$I_{(ISNx_leakage)}$	Leakage current sink on ISNx pins			1.3	2.3	μA
INTERNAL PWM DIMMING						
$V_{(PWMCHG_th_rising)}$	Internal PWM generator, rising threshold		1.45	1.48	1.51	V
$V_{(PWMCHG_th_falling)}$	Internal PWM generator, falling threshold		0.78	0.8	0.82	V
$V_{(PWMCHG_th_hys)}$	Internal PWM generator hysteresis			0.68		V
$I_{(PWMCHG)}$	PWM generator pullup current	$V_{(PWMCHG)} = 0\text{ V}$, $FD = \text{LOW}$	194	200	206	μA
$V_{OL(PWMOUT)}$	Open-drain PWMOUT pulldown voltage	$V_{(PWMCHG)} = 3\text{ V}$, $I_{(PWMOUT)}$ pullup current = 4 mA			0.4	V
$r_{DS(on)(PWMOUT)}$	Open-drain PWMOUT pulldown MOSFET $r_{DS(on)}$		40	55	90	Ω
ANALOG DIMMING						
$V_{(ICTRL_FULL)}$	Full-range ICTRL voltage				1.65	V
$V_{(ICTRL_LIN_TOP)}$	Upper boundary for linear ICTRL dimming			1.425		V
$V_{(ICTRL_LIN_BOT)}$	Lower boundary for linear ICTRL dimming			75		mV
$\Delta V_{(CS_ICTRL_H)}$	Analog dimming accuracy	$V_{(ICTRL)} = 1.35\text{ V}$, $V_{(DERATE)} = 0\text{ V}$, accuracy: $1 - (V_{(CS_REG_x)} / 0.27)$, $x = 1, 2, 3$	-2.5%		2%	
$\Delta V_{(CS_ICTRL_M)}$	Analog dimming accuracy	$V_{(ICTRL)} = 0.75\text{ V}$, $V_{(DERATE)} = 0\text{ V}$, accuracy: $1 - (V_{(CS_REG_x)} / 0.15)$, $x = 1, 2, 3$	-4%		4%	
$\Delta V_{(CS_ICTRL_L)}$	Analog dimming accuracy	$V_{(ICTRL)} = 0.15\text{ V}$, $V_{(DERATE)} = 0\text{ V}$, accuracy: $1 - V_{(CS_REG_x)} / 0.03$, $x = 1, 2, 3$	-18%		18%	
$I_{(ICTRL_pullup)}$	ICTRL internal pullup current		0.95	0.985	1.02	mA
CURRENT DERATING						
$V_{(DERATE_FULL)}$	Full-range DERATE voltage			1.83		V
$V_{(DERATE_HALF)}$	Half-range DERATE voltage			2.38		V
$K_{(DERATE)}$	Derate dimming ratio	$V_{(DERATE)} = 1.966\text{ V}$	81%	87%	95%	
		$V_{(DERATE)} = 2.316\text{ V}$	51%	58%	65%	
DIAGNOSTICS						
$V_{(OPEN_th_rising)}$	LED open rising threshold, device triggers open-circuit diagnostics $V_{(SG_th_rising)}$, and $V_{(SG_th_falling)}$ in the <i>Electrical Characteristics</i> table	$V_{(ISNx)} - V_{(SENSEx)}$, $x = 1, 2, 3$	100	145	190	mV
$V_{(OPEN_th_falling)}$	LED open falling threshold, device releases from open-circuit diagnostics	$V_{(ISNx)} - V_{(SENSEx)}$, $x = 1, 2, 3$	240	280	320	mV
$V_{(OPEN_th_hyst)}$				135		mV
$I_{(Retry_open)}$	LED-open retry current		8	10	12	mA

Electrical Characteristics (continued)

 $V_{IN} = 5\text{ V to }40\text{ V}$, $V_{ICTRL} = 3\text{ V}$, $V_{DERATE} = 0\text{ V}$, $T_J = -40^\circ\text{C to }150^\circ\text{C}$,⁽¹⁾ (unless otherwise noted)

PARAMETER	TEST CONDITIONS	MIN	TYP	MAX	UNIT
$V_{(SG_th_rising)}$	Channel output V_{SENSEx} short-to-ground rising threshold, device triggers short-to-ground diagnostics	0.885	0.92	0.95	V
$V_{(SG_th_falling)}$	Channel output V_{SENSEx} short-to-ground falling threshold, device releases from short-to-ground diagnostics	1.17	1.215	1.26	V
$V_{(SG_th_hyst)}$	Channel output V_{SENSEx} short-to-ground hysteresis		295		mV
$I_{(Retry_short)}$	Channel output V_{SENSEx} short-to-ground retry current	0.75	1	1.25	mA
FAULT					
$V_{IL(FAULT)}$	Logic-input low threshold			0.7	V
$V_{IH(FAULT)}$	Logic-input high threshold	2			V
$V_{OL(FAULT)}$	Logic-output low threshold	With 500- μ A external pullup		0.4	V
$V_{OH(FAULT)}$	Logic-output high threshold	With 1- μ A external pulldown		3.4	V
$I_{(FAULT_pulldown)}$	\overline{FAULT} internal pulldown current	650	750	800	μ A
$I_{(FAULT_pullup)}$	\overline{FAULT} internal pullup current	6.5	7.6	9.5	μ A
THERMAL PROTECTION					
$T_{(TSD)}$	Thermal shutdown threshold		176		$^\circ\text{C}$
$T_{(TSD_HYS)}$	Thermal shutdown hysteresis		15		$^\circ\text{C}$

7.6 Timing Requirements

		MIN	NOM	MAX	UNIT
$t_{(OPEN_deg)}$	LED open-circuit deglitch time, described in LED open-circuit diagnostics section	100	125	150	μs
$t_{(SG_deg)}$	LED short-to-GND detection deglitch time, described in the LED short-to-GND diagnostics section	100	125	150	μs
$t_{(SG_retry_ON)}$	Channel output SENSEx short-to-ground retry on-time, described in the LED short-to-GND auto retry section	100	125	150	μs
$t_{(SG_retry_OFF)}$	Channel output SENSEx short-to-ground retry off-time, described in LED short-to-GND auto retry section		10.8		ms
$t_{(OPEN_retry_ON)}$	Channel output SENSEx open-circuit retry on-time	100	125	150	μs
$t_{(OPEN_retry_OFF)}$	Channel output SENSEx open-circuit retry off-time		10.8		ms
$D_{(PWM_10)}$	PWM duty cycle generated internally, nominal 10% duty cycle, as measured on output channel; see Figure 1 , $T_{(J)} = 25^\circ\text{C}$	9.8%	10%	10.2%	
	PWM duty cycle generated internally, nominal 10% duty cycle, as measured on output channel; see Figure 1 , $T_{(J)} = -40^\circ\text{C to }150^\circ\text{C}$	9.75%	10%	10.25%	
$t_{d(DERATE)}$	Derate current-response delay time when DERATE steps from 1.8 V to 2.4 V		25		μs
$t_{(CP_STARTUP)}$	$V_{(IN)} = 14\text{ V}$, $C_s = 150\text{ nF}$, CPOUT voltage reaches 18 V as shown in Device Start-Up Delay diagram		25		μs
$f_{(DRV_PWM)}$	Recommended PWM driving-frequency range			2000	Hz

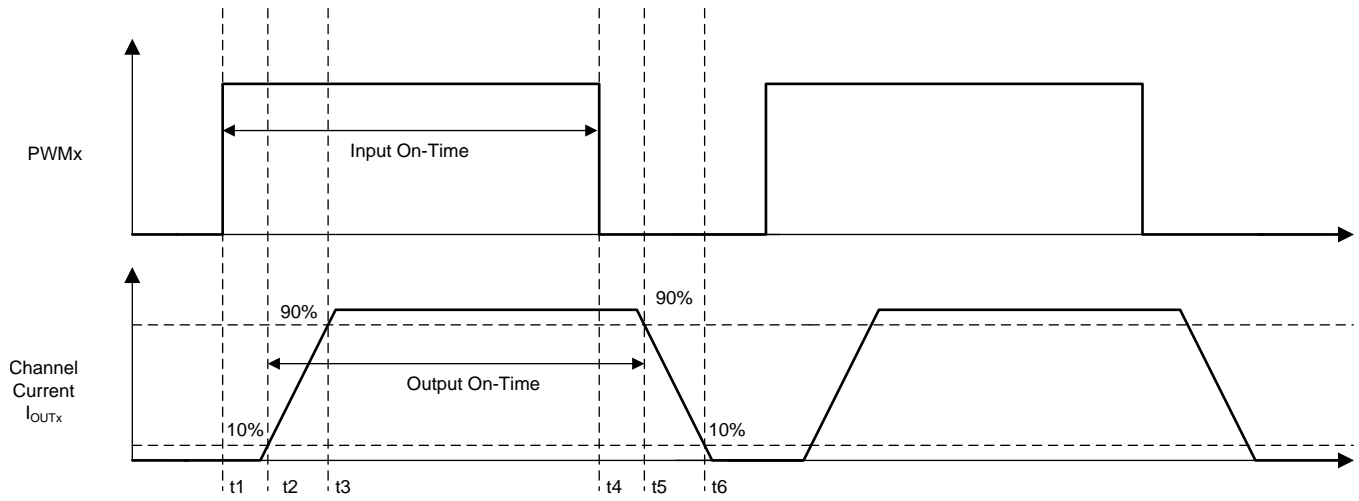

Copyright © 2017, Texas Instruments Incorporated

图 1. Channel-Current Output Timing Diagram

7.7 Typical Characteristics

T_A = 25 °C unless otherwise noted

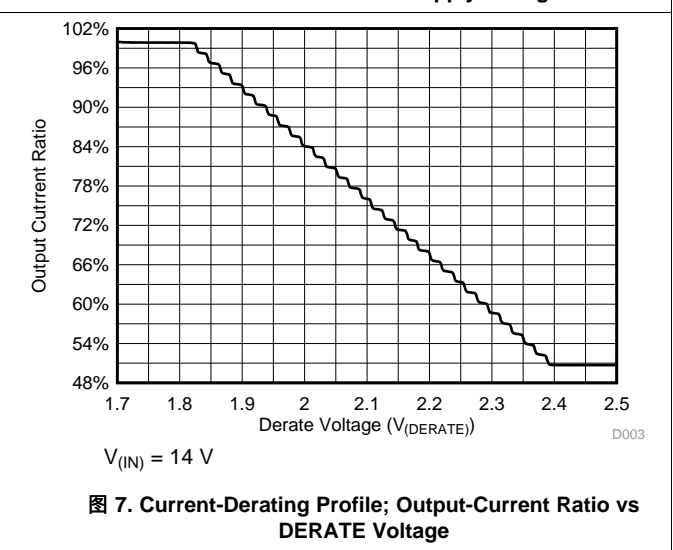
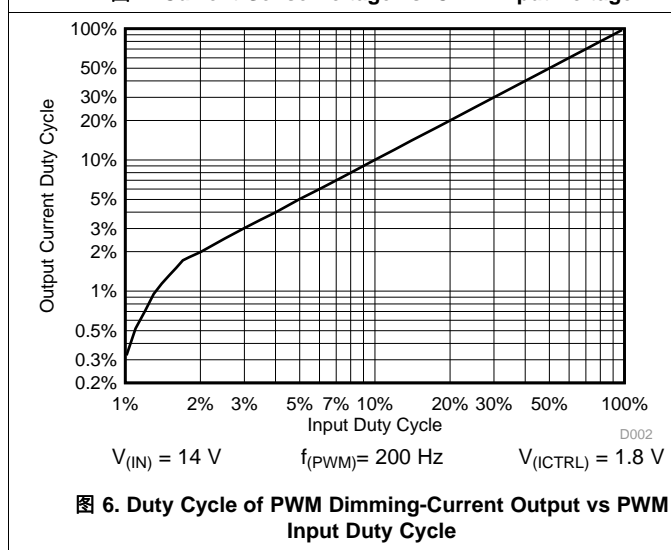
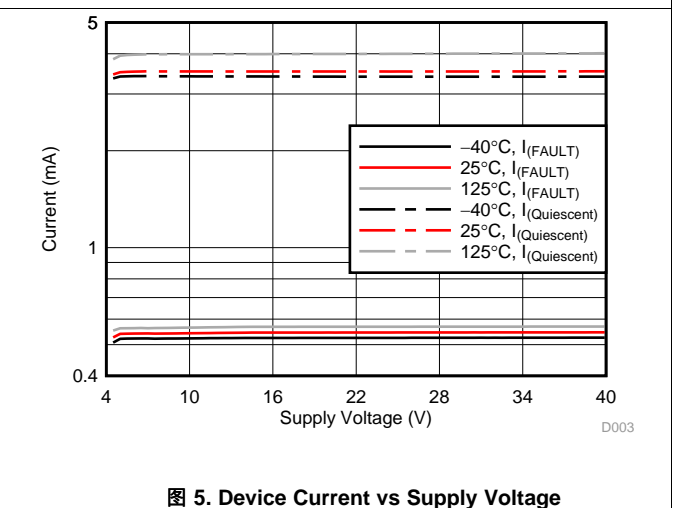
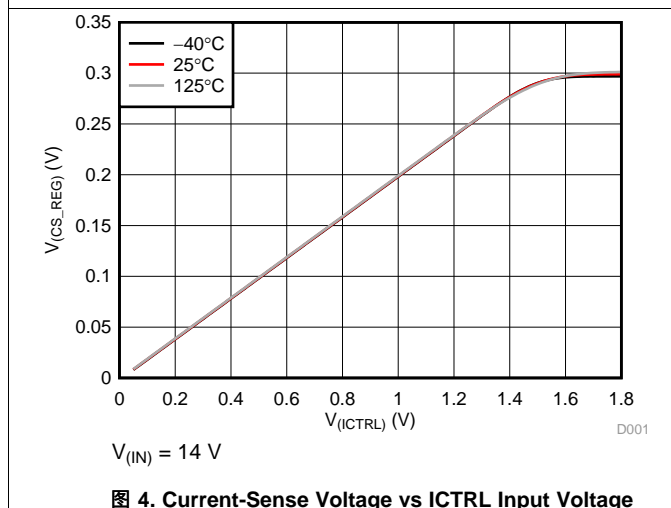
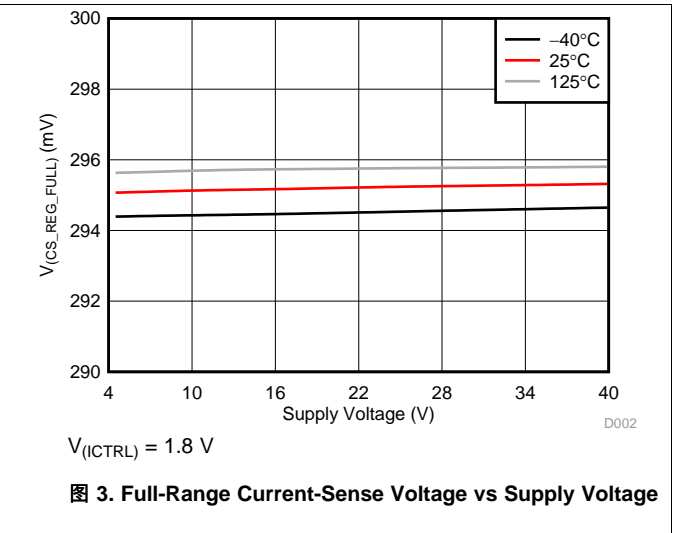
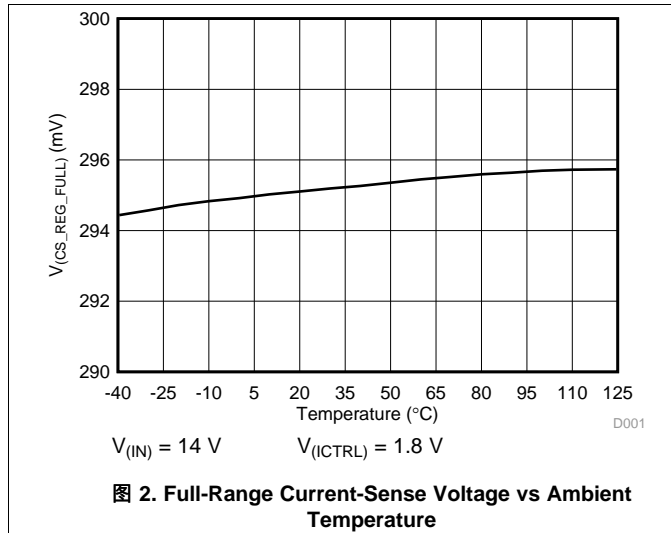

Typical Characteristics (接下页)

T_A = 25 °C unless otherwise noted

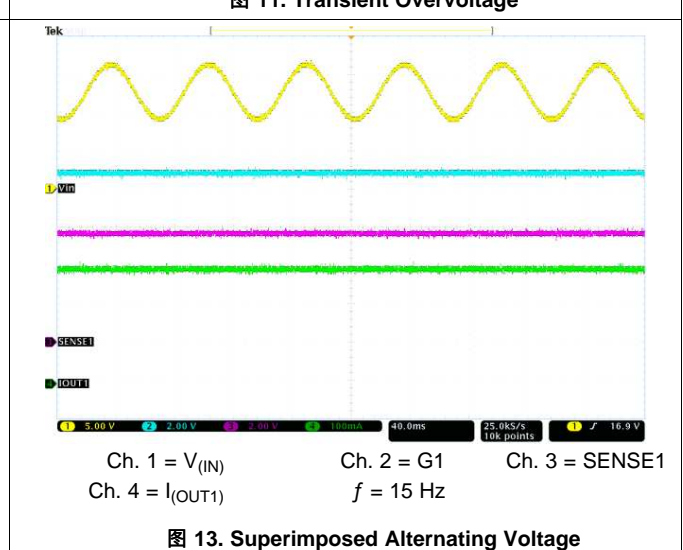
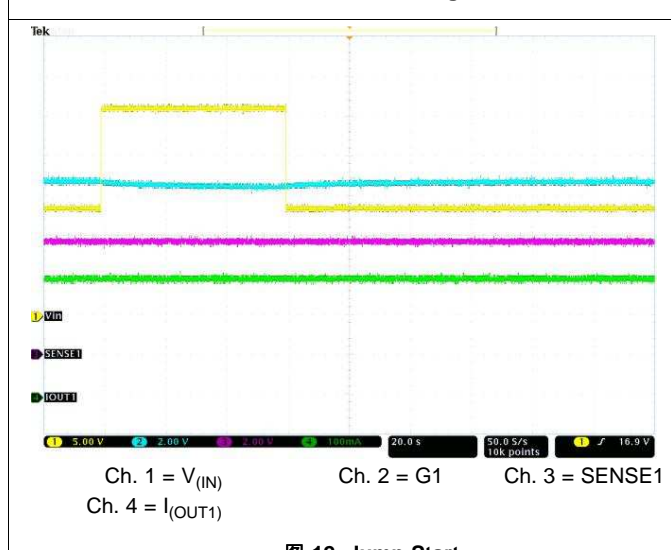
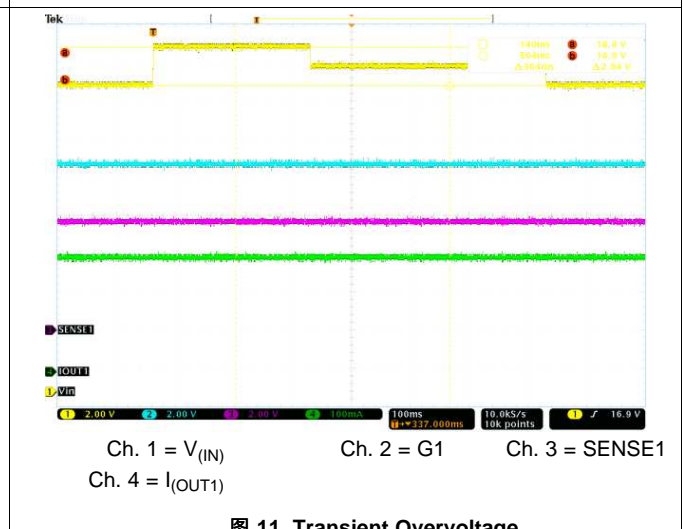
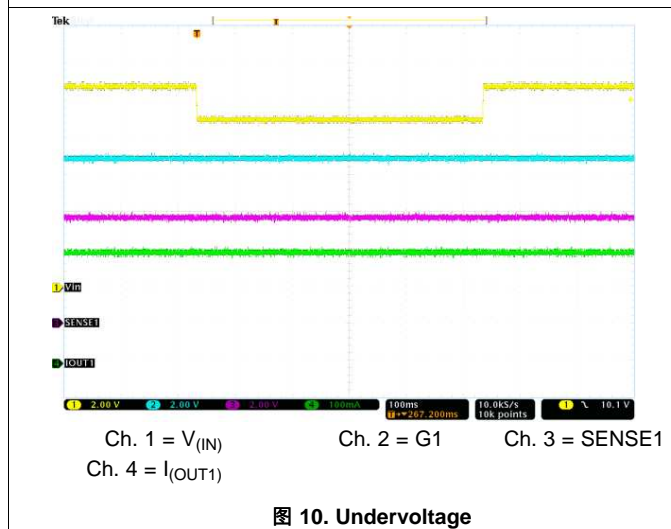
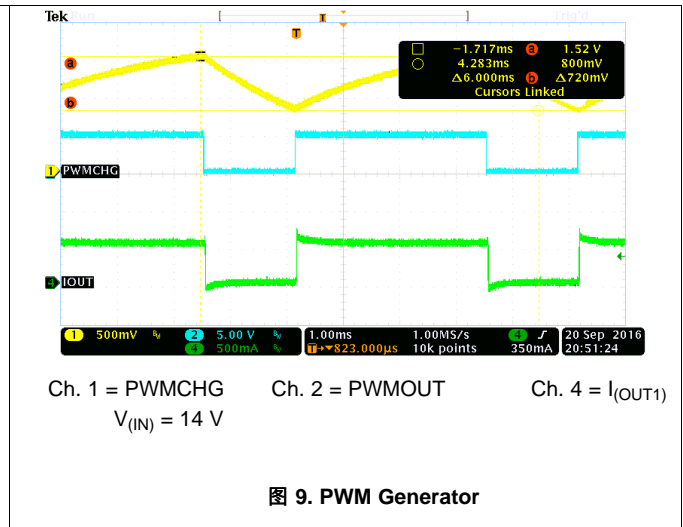
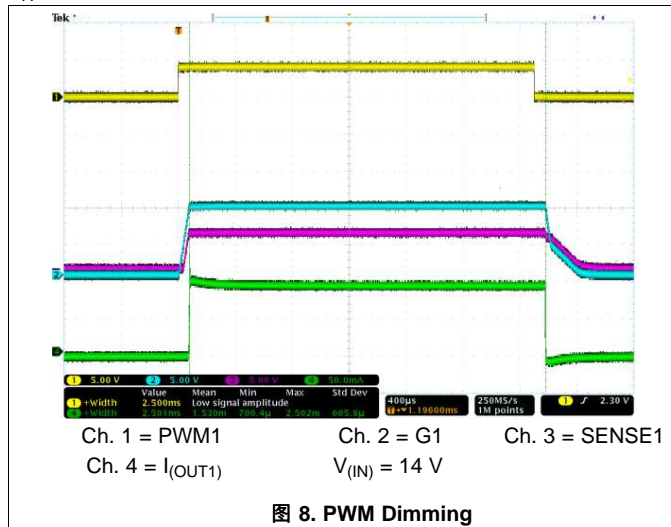

Typical Characteristics (接下页)

T_A = 25 °C unless otherwise noted



图 14. Fast Power Down and Slow Power Up



图 15. Slow Decrease, Quick Increase of Supply Voltage

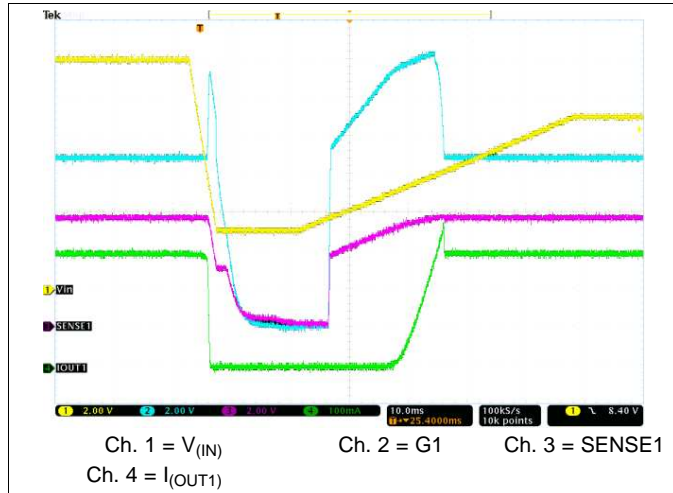

图 16. Slow Decrease and Slow Increase of Supply Voltage

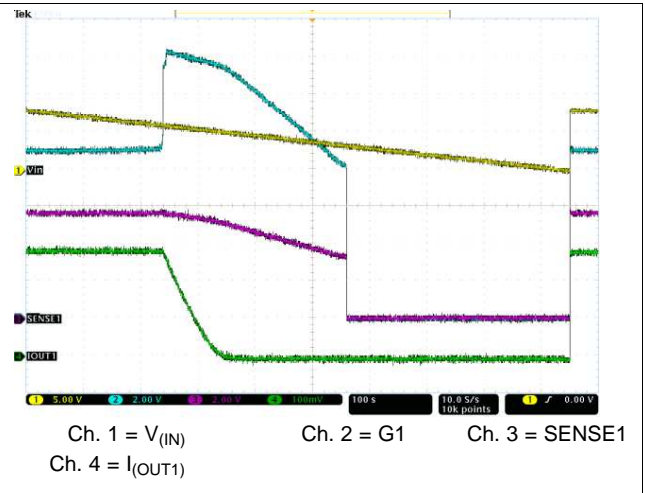

图 17. LED Open-Circuit Protection and One-Fails-All-Fail

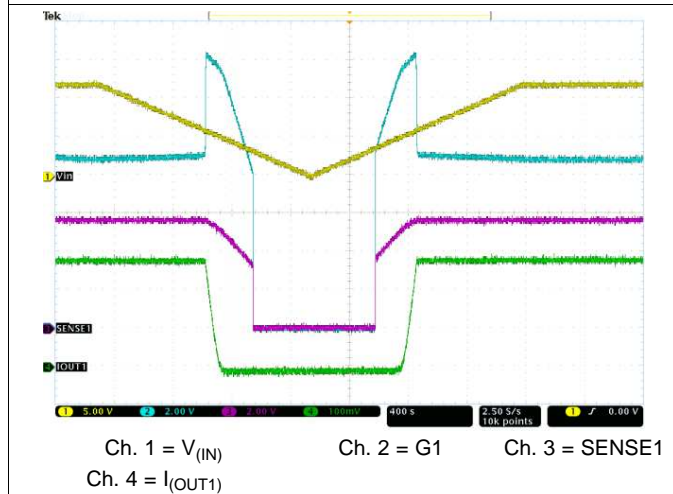

图 18. LED Hard Short Protection and One-Fails-All-Fail

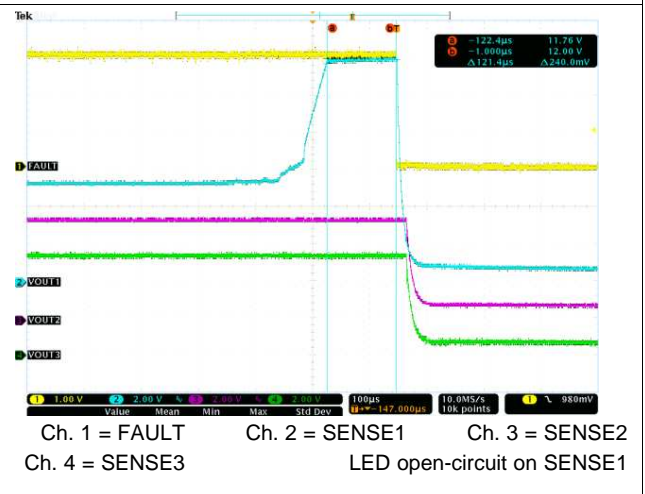

图 19. Device Start-Up Delay

8 Detailed Description

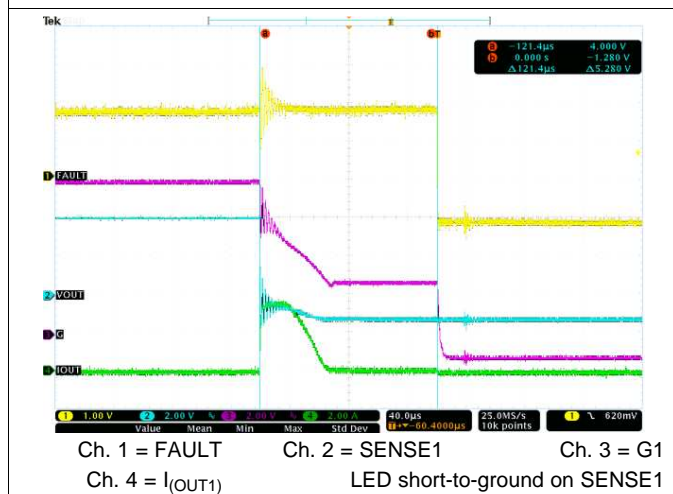
8.1 Overview

The TPS92830-Q1 device is an advanced automotive-grade high-side constant-current linear LED controller for delivering high current using external N-channel MOSFETs. The device has a full set of features for automotive applications. Each channel of the TPS92830-Q1 device sets the channel current independently by the sense-resistor value. An internal precision constant-current regulation loop senses the channel current by the voltage across the sense resistor and controls the gate voltage of the N-channel MOSFET accordingly. The device also integrates a two-stage charge pump for low-dropout operation. The charge-pump voltage is high enough to support a wide selection of N-channel MOSFETs. PWM dimming allows multiple sources for flexibility—internal PWM generator, external PWM inputs, or power-supply dimming. Various diagnostics and protection features specially designed for automotive applications help improve system robustness and ease of use. A one-fails-all-fail fault bus supports TPS92830-Q1 operation together with the TPS92630-Q1, TPS92638-Q1, and TPS9261x-Q1 family to fulfill various fault-handling requirements.

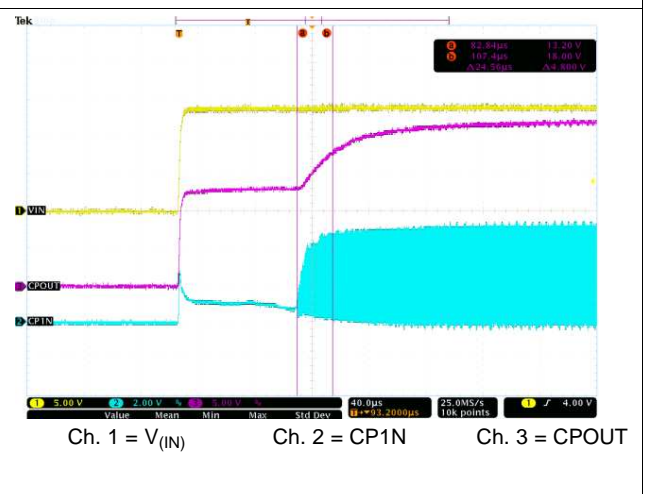
8.2 Functional Block Diagram

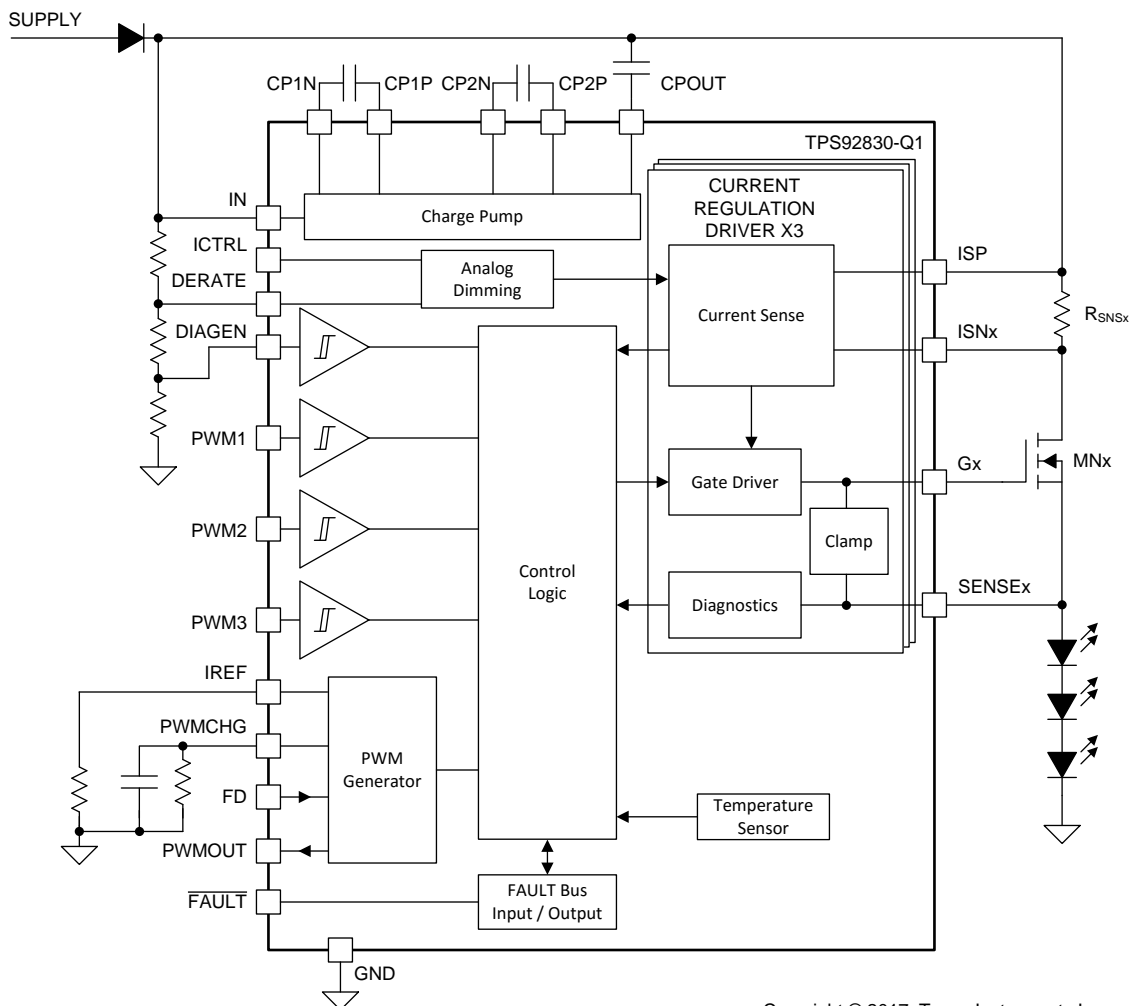

Copyright © 2017, Texas Instruments Incorporated

8.3 Feature Description

The TPS92830-Q1 device uses IN voltage to generate device bias. A two-stage charge pump provides gate driving voltage above the IN voltage for the high-side N-channel MOSFET. Each channel current is independently set by sense resistors. The analog-dimming ICTRL input supports off-board resistors as bin-setting resistors as well as direct voltage input. An integrated precision PWM generator could be used for PWM dimming locally.

8.3.1 Device Bias

The TPS92830-Q1 device has internal bias-generation and power-on-reset circuits for internal bias.

8.3.1.1 Power-On-Reset (POR)

The TPS92830-Q1 device has an internal power-on-reset (POR) function. When power is applied to IN, the internal POR holds the device in the reset condition until V_{IN} reaches $V_{(POR_rising)}$.

When the supply rises above POR threshold $V_{(POR_rising)}$, the charge pump starts working. The maximum gate-drive voltage is determined by the charge-pump voltage between CPOUT and IN.

8.3.1.2 Current Reference (IREF)

The TPS92830-Q1 device has a constant reference-voltage output on the IREF pin and uses current $I_{(IREF)}$ as the internal current reference. The analog-dimming internal-pullup current on ICTRL, and the PWM-generator internal charge current on PWMCHG, use $I_{(IREF)}$ as a reference current. The recommended value of reference resistor $R_{(IREF)}$ for IREF is 8 k Ω .

8.3.1.3 Low-Current Fault Mode

The TPS92830-Q1 device consumes minimal quiescent current when it is in fault mode. If the \overline{FAULT} voltage is pulled low either by internal diagnostics or externally, the device performs as follows:

- The charge pump is shut down.
- All drivers are turned off with their gates internally pulled down.
- The PWM generator and PWMOUT are turned off.
- IREF current is turned off.
- ICTRL current is turned off.

8.3.2 Charge Pump

8.3.2.1 Charge Pump Architecture

The TPS92830-Q1 device uses a two-stage charge pump to generate the high-side gate-drive voltage. The charge pump is a voltage tripler using external flying and storage capacitors.

C_{P1} is the first-stage flying capacitor, connected between CP1P and CP1N, which are the positive and negative nodes, respectively. C_{P2} is the second-stage flying capacitor, connected between CP2P and CP2N, which are the positive and negative nodes, respectively. C_S is the storage capacitor, connected between CPOUT and IN. C_S stores charge for the high-side gate driver.

The charge pump switches at frequency $f_{(cp_sw)}$ to optimize EMI performance.

Negative nodes CP1N and CP2N are driven by a 5-V driver, thus the maximum voltage on charge-pump output node CPOUT is approximately $V_{(IN)} + V_{(CP_drv)}$. The charge pump voltage across storage capacitor C_S is not dependent on $V_{(IN)}$.

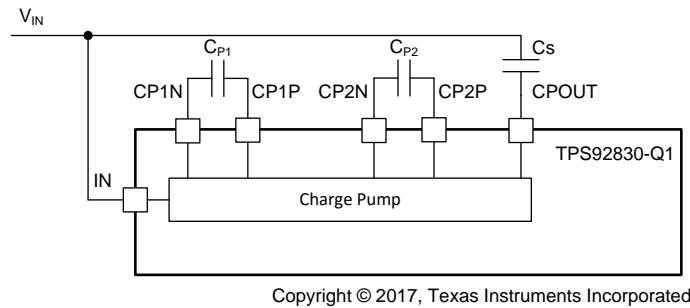
Feature Description (接下页)

图 20. Charge Pump
8.3.3 Constant-Current Driving

The TPS92830-Q1 device has three independent constant-current driving channels. Each channel sets channel current with an external high-side current-sense resistor, R_{SNSx} . Channel current is set as $V_{(\text{CS_REG})} / R_{\text{SNSx}}$.

Considering that both ICTRL and DERATE voltages reduce current-sense voltage $V_{(\text{CS_REG})}$ independently, channel current can be calculated using the following equation. Each of the dimming ratios is described separately in following sections.

$$I_{(\text{CHx})} = \frac{V_{(\text{CS_REG_FULL})} \times k_{(\text{ICTRL_DIM})} \times k_{(\text{DERATE_DIM})}}{R_{\text{SNSx}}} \quad (1)$$

8.3.3.1 High-Side Current Sense

The sense voltage across external current-sense resistor R_{SNSx} feeds back current information to the controller. An internal feedback control loop within the TPS92830-Q1 device regulates the external gate-overdrive voltage of the N-channel MOS transistor to keep the sense voltage at the desired level. By setting the external current-sense resistance value, the output current can be set individually on each channel.

8.3.3.2 High-Side Current Driving

To regulate the output current, the gate-source voltage of the external MOSFET must be regulated accordingly. The constant-current source is used to charge and discharge the N-channel MOSFET gate. During the current-slewing period, constant-current sourcing and sinking ensures the smooth slewing of the output current. The control loop requires sufficient MOSFET gate capacitance to ensure loop stability. In case the MOSFET gate capacitance is insufficient, a capacitor C_{GS} must be added across G_x and SENSE_x . TI also recommends always putting a C_{SENSE} of 10 nF from each of the SENSE_x pins to GND, and close to the device for EMC.

When a channel is switched on, current source $I_{(\text{DRV_source})}$ charges the gate of the external N-channel MOSFET. When a channel is switched off, current sink $I_{(\text{DRV_sink})}$ discharges the gate of the external MOSFET transistor down to ground.

Feature Description (接下页)



图 21. MOSFET Gate Capacitance Compensation

8.3.3.3 Gate Overdrive Voltage Protection

A bidirectional clamp is used to protect the gate-source path of the external N-channel MOSFETs from overstress conditions. Gate-source voltage $V_{(GS)}$ is clamped between $V_{(GS_clamp_neg)}$ and $V_{(GS_clamp_pos)}$ for MOSFET protection.

8.3.3.4 High-Precision Current Regulation

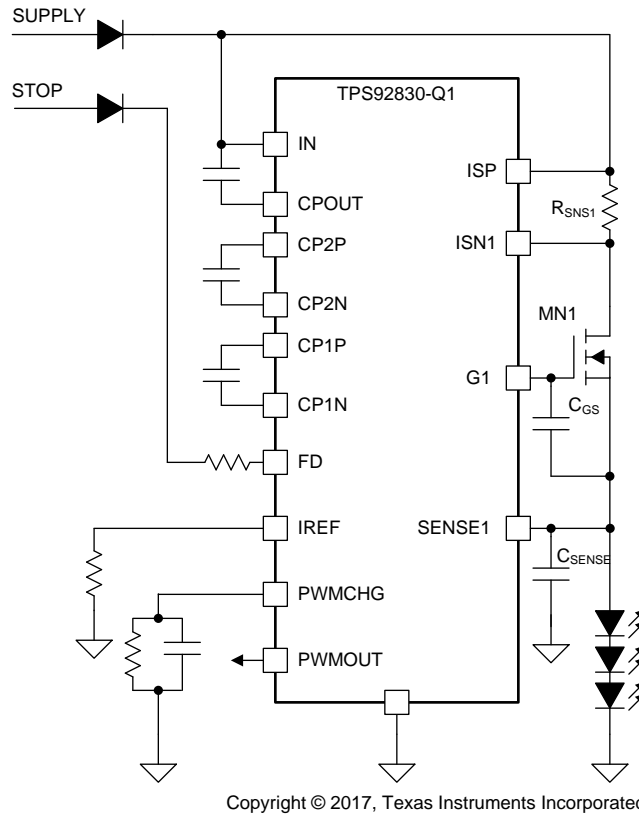
The TPS92830-Q1 device has a high-precision current-regulation loop. Its precision is at the maximum when the voltage across the current-sense resistor is set to maximum. The analog-dimming or current-derating function reduces the current-sense voltage, thus decreasing current-regulation accuracy.

8.3.3.5 Parallel MOSFET Driving

The TPS92830-Q1 device is designed to support parallel N-channel MOSFETs driving within the same channel. To balance heat dissipation, multiple MOSFETs could be paralleled together. A ballast resistor for each MOSFET is recommended to balance current distribution among parallel MOSFETs.

Larger variation on threshold mismatches requires larger ballast resistors. $V_{(TH_MISMATCH)}$ is the threshold for mismatches within the same batch of MOSFETs. $I_{(CH_MISMATCH)}$ is the allowed mismatch current between the parallel channels. Typically, $I_{(CH_MISMATCH)}$ can be set to 10% of full-range current. The ballast resistor value is set as calculated in the following equation.

$$R_{(Ballast)} = \frac{V_{(TH_MISMATCH)}}{I_{(CH_MISMATCH)}} \tag{2}$$

The ballast resistor typically ranges from hundreds of milliohms to several ohms depending on the channel current and MOSFET threshold-voltage variations.

Feature Description (接下页)

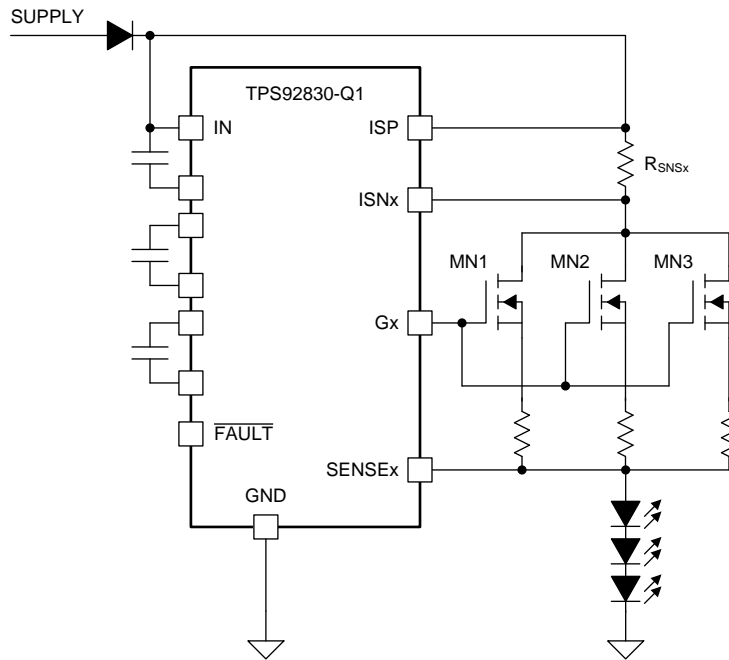

Copyright © 2017, Texas Instruments Incorporated

图 22. Parallel MOSFET Driving

8.3.4 PWM Dimming

The TPS92830-Q1 device supports a variety of PWM dimming methods, including PWM supply dimming, external PWM dimming by inputs, and internal PWM dimming by the internal PWM generator. Each PWM cycle should allow enough positive cycle time for gate charging and enough negative cycle time for gate discharging in order to achieve an accurate PWM dimming duty cycle.

8.3.4.1 Supply Dimming

In the case of supply dimming, the supply of the whole LED driver module is PWM dimmed, for example by body-control-module (BCM) high-side switches. The TPS92830-Q1 device supports supply dimming with a short power-on delay. Device supply V_{IN} should be always equal to $V_{(ISP)}$ to ensure that the charge pump voltage is high enough to turn on the MOSFET.

When supply dimming is used, it is recommended to be used together with PWM input, so that the channel is only turned on when the input voltage is above the device UVLO threshold. By keeping enough delay time between device power up and channel turnon, output current spikes can be avoided to ease EMC design.

8.3.4.2 PWM Dimming by Input

Each channel has individual PWM dimming by inputs.

The internal thresholds for PWM1–PWM3 are designed with high precision. With external resistor dividers, each channel threshold can be set flexibly and independently.

8.3.4.3 Internal Precision PWM Generator

The TPS92830-Q1 device has an integrated precision PWM generator for on-chip PWM dimming as shown in . The device supports open-drain PWMOUT for synchronization between devices. Each device can be connected as a master, generating PWM, or as a slave, relying on external PWM sources. An external RC circuit precisely sets the duty cycle of the PWM generator across a wide duty-cycle range. Variation of the capacitor value affects the output frequency but not the duty cycle.

The PWM generator uses reference current $2 \times I_{(IREF)}$ as the internal charge current, $I_{(PWMCHG)}$.

Feature Description (接下页)

When $V_{(PWMCHG)}$ increases above rising threshold $V_{(PWMCHG_th_rising)}$, the constant-current source is turned off and $V_{(PWMCHG)}$ decays through the external resistor-capacitor circuit. The PWM output is set LOW. The PWMCHG threshold is set to $V_{(PWMCHG_th_falling)}$. When $V_{(PWMCHG)}$ decreases below falling threshold $V_{(PWMCHG_th_falling)}$, the constant-current source is turned on again to charge up the external capacitor. The PWM output is HIGH and the threshold is set to $V_{(PWMCHG_th_rising)}$.

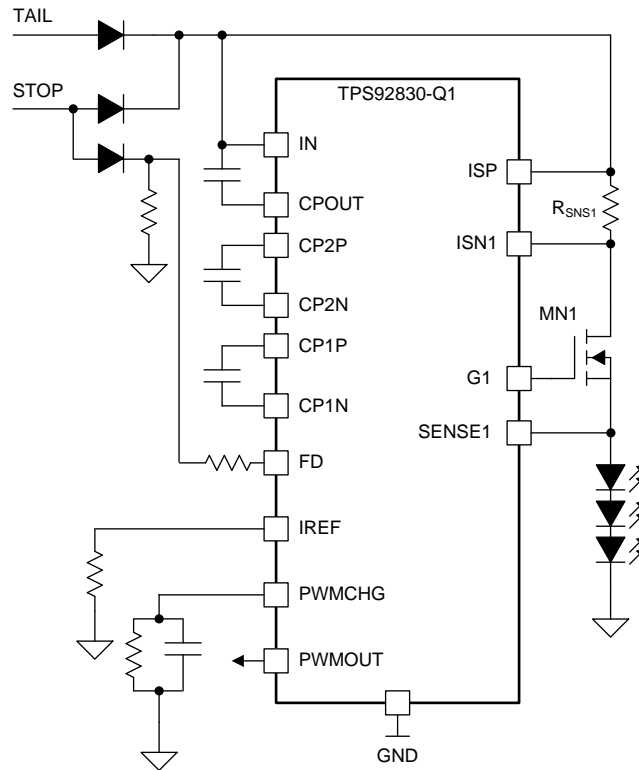

Copyright © 2017, Texas Instruments Incorporated

图 23. PWM Generator Dual-Brightness Configuration

An external resistor $R_{(PWMEXT)}$ and capacitor $C_{(PWMEXT)}$ are used to set the PWM cycle time.

$$t_{(PWM_ON)} = R_{(PWMEXT)} \times C_{(PWMEXT)} \times \ln \left(\frac{V_{(PWMCHG_th_falling)} - I_{(PWMCHG)} \times R_{(PWMEXT)}}{V_{(PWMCHG_th_rising)} - I_{(PWMCHG)} \times R_{(PWMEXT)}} \right) \quad (3)$$

$$t_{(PWM_OFF)} = R_{(PWMEXT)} \times C_{(PWMEXT)} \times \ln \left(\frac{V_{(PWMCHG_th_rising)}}{V_{(PWMCHG_th_falling)}} \right) \quad (4)$$

$$f_{(PWMEXT)} = \frac{1}{R_{(PWMEXT)} \times C_{(PWMEXT)} \times \left[\ln \left(\frac{V_{(PWMCHG_th_falling)} - I_{(PWMCHG)} \times R_{(PWMEXT)}}{V_{(PWMCHG_th_rising)} - I_{(PWMCHG)} \times R_{(PWMEXT)}} \right) + \ln \left(\frac{V_{(PWMCHG_th_rising)}}{V_{(PWMCHG_th_falling)}} \right) \right]} \quad (5)$$

$$D_{(PWMEXT)} = \frac{\ln \left(\frac{V_{(PWMCHG_th_falling)} - I_{(PWMCHG)} \times R_{(PWMEXT)}}{V_{(PWMCHG_th_rising)} - I_{(PWMCHG)} \times R_{(PWMEXT)}} \right)}{\ln \left(\frac{V_{(PWMCHG_th_falling)} - I_{(PWMCHG)} \times R_{(PWMEXT)}}{V_{(PWMCHG_th_rising)} - I_{(PWMCHG)} \times R_{(PWMEXT)}} \right) + \ln \left(\frac{V_{(PWMCHG_th_rising)}}{V_{(PWMCHG_th_falling)}} \right)} \quad (6)$$

Feature Description (接下页)



图 24. PWM Dimming Profile

8.3.4.4 Full Duty-Cycle Switch

The TPS92830-Q1 device can flexibly switch between the internal PWM modulation mode and the 100% duty-cycle mode by using the FD input. Once $V_{(FD)}$ is higher than threshold $V_{IH(FD)}$, the internal PWM generator is bypassed and output is merely controlled by the PWM inputs.

If FD is HIGH, the PWMCHG current source is turned off and $V_{(PWMCHG)}$ decays to GND through the external resistor-capacitor circuit. When FD falls below the threshold, $V_{(PWMCHG)}$ increases from GND due to the internal charge current.

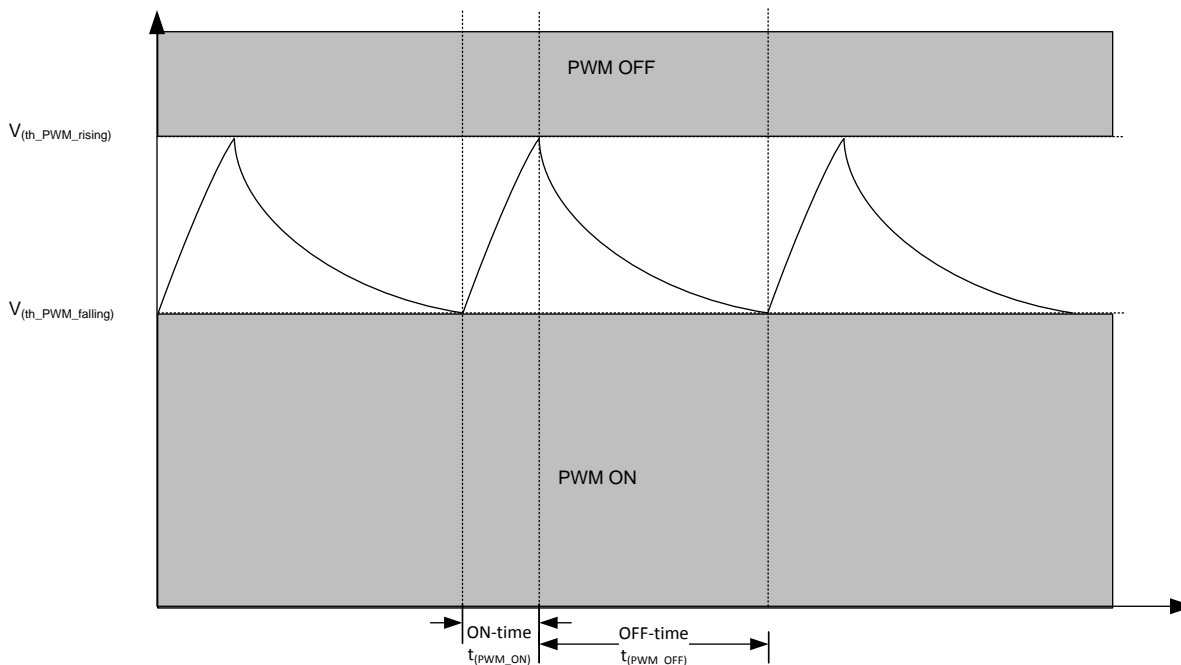
If FD is HIGH, PWM generator oscillation stops, and PWMOUT is controlled by PWM1 only.

External PWM inputs and internal PWM inputs are combined together for channel PWM dimming, or external PWM inputs can be used as channel enable inputs.

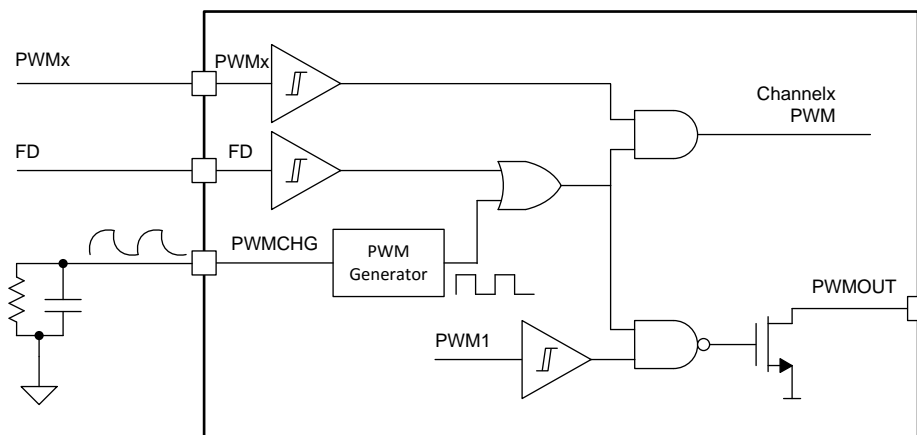

Copyright © 2017, Texas Instruments Incorporated

图 25. PWM Dimming Internal Block Diagram

Feature Description (接下页)
表 1. Truth Table When Driving With PWM

PWMx	FD	PWMCHG	CHANNELx PWM
LOW	X	X	LOW
HIGH	HIGH	X	HIGH
HIGH	LOW	R-C	PWM generated with RC

表 2. Truth Table When Driving With PWMOUT

PWM1	FD	PWMCHG	PWMOUT
LOW	X	X	LOW
HIGH	HIGH	X	HIGH
HIGH	LOW	R-C	PWM generated with RC

8.3.5 Analog Dimming

The TPS92830-Q1 device has a linear analog input pin, ICTRL, for output-current dimming. Voltage across the sense resistors is linearly reduced if the ICTRL input voltage $V_{(ICTRL)}$ decreases. Analog dimming can be used for brightness control, LED bin brightness correction, and thermal protection with a thermistor. ICTRL also supports off-board connection for LED binning and thermistor connection.

8.3.5.1 Analog Dimming Topology

Voltage at the ICTRL pin, $V_{(ICTRL)}$, is used for analog dimming control. To set $V_{(ICTRL)}$, either a reference input voltage can be applied or a resistor between ICTRL and GND can be used.

When $V_{(ICTRL)}$ is greater than $V_{(ICTRL_FULL)}$, analog dimming is not enabled; thus the analog dimming ratio is at 100%.

When $V_{(ICTRL)}$ is between $V_{(ICTRL_LIN_BOT)}$ and $V_{(ICTRL_LIN_TOP)}$, the analog dimming ratio is directly proportional to $V_{(ICTRL)}$. The analog dimming ratio can be calculated using the following equation. $V_{(ICTRL_LIN_BOT)}$ and $V_{(ICTRL_LIN_TOP)}$ represent the ICTRL voltage boundaries of the linear region.

$$k_{(ICTRL_DIM)} = \frac{V_{(ICTRL)}}{1.475\text{ V}} \times 100\% \quad (7)$$

When V_{ICTRL} is between $V_{(ICTRL_LIN_TOP)}$ and $V_{(ICTRL_FULL)}$ or between $V_{(ICTRL_LIN_BOT)}$ and 0, analog dimming is in a transition region, and linearity is not assured. Thus it is not recommended to use ICTRL in these regions.

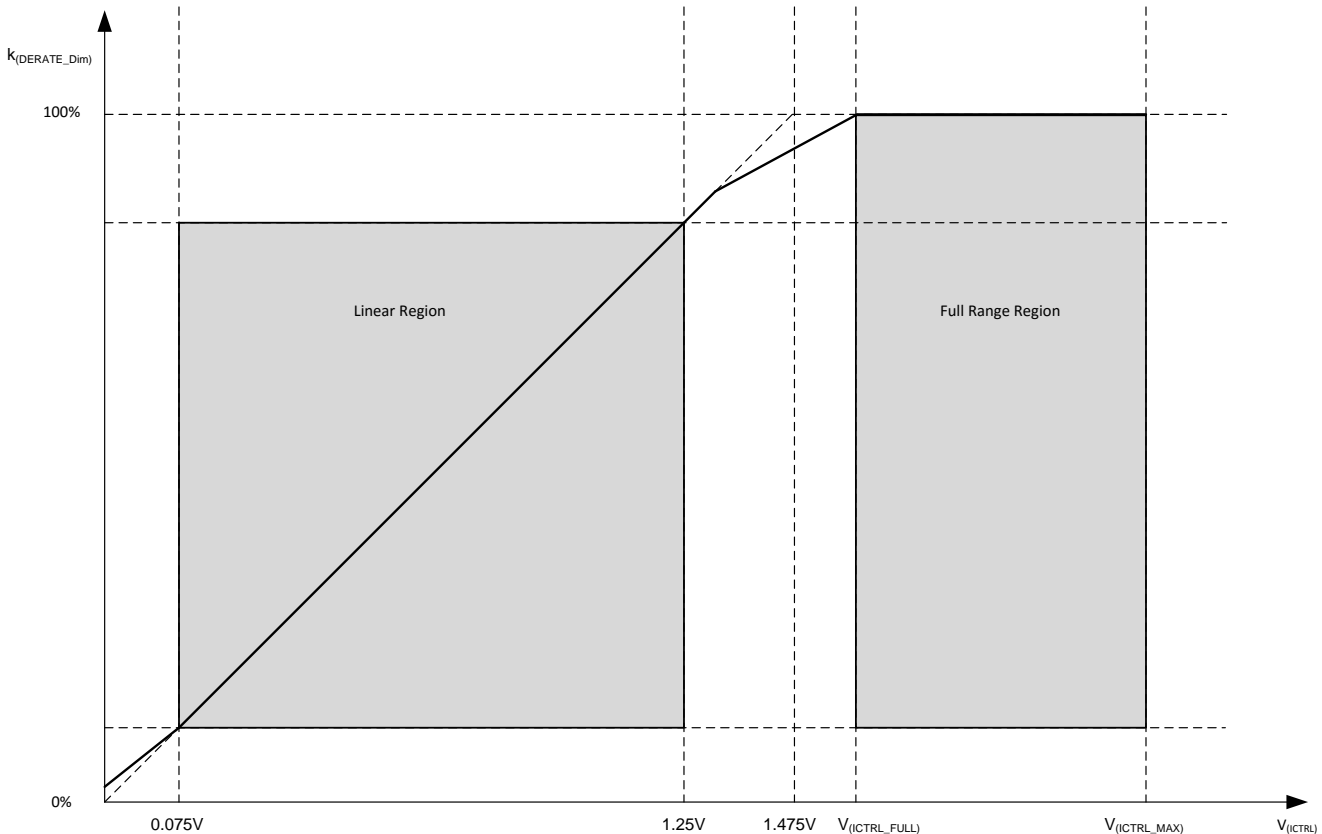

Copyright © 2017, Texas Instruments Incorporated

图 26. Analog Dimming Ratio

8.3.5.2 Internal High-Precision Pullup Current Source

An internal precision pullup current $I_{(ICTRL_pullup)}$ is provided within the device to minimize external component count. $I_{(ICTRL_pullup)}$ uses current reference $I_{(IREF)}$ as reference. With the internal pullup current source, only an external resistor between the ICTRL pin and GND is needed to set the ICTRL voltage and the analog dimming ratio.

If a voltage source or resistor divider is used, the internal pullup current must be taken into account to set the analog dimming ratio accurately.

The pullup current source pulls the ICTRL pin voltage up to input voltage $V_{(IN)}$ if the ICTRL pin is unconnected. When ICTRL is not used, it is recommended to leave the ICTRL pin floating.

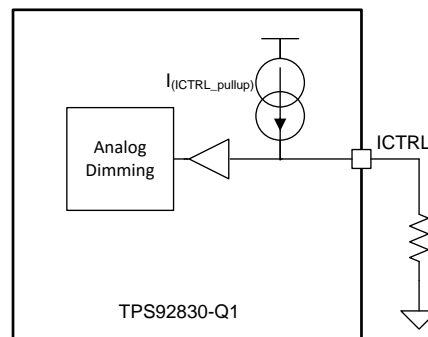

Copyright © 2017, Texas Instruments Incorporated

图 27. Internal High-Precision Pullup Current Source

8.3.6 Output Current Derating

The TPS92830-Q1 device has an integrated output-current derating function. Voltage across the sensing resistors is reduced if DERATE input voltage V_{DERATE} increases. The output current derating function can be used for supply overvoltage protection and thermal protection with a thermistor. The DERATE current curves are divided into 32 steps between 100% and 50% with hysteresis.

In the case where DERATE is used for battery voltage sensing, the resistor-divider ratio can be set in a typical application as follows.

- In the normal supply-voltage range, for example, (9 V–16 V), the output-current-derating function is disabled.
- In the overvoltage range, for example, (18 V–24 V), the output current starts to derate and reaches 50% when V_{IN} is at 24 V.
- When the voltage is even higher, for example, (24 V–26 V), the output current is saturated at 50%.

8.3.6.1 Output-Current Derating Topology

Voltage at the DERATE pin, $V_{\text{(DERATE)}}$, is used for output-current-derating control. To set the $V_{\text{(DERATE)}}$ voltage, a resistor divider on supply voltage V_{IN} is typically used for supply overvoltage protection.

- When V_{DERATE} is lower than $V_{\text{(DERATE_FULL)}}$, output current derating is not enabled; thus, output-current derating ratio $k_{\text{(DERATE_Dim)}}$ is at 100%.
- When V_{DERATE} is higher than $V_{\text{(DERATE_HALF)}}$, output current derating is limited to 50%; thus, output-current derating ratio $k_{\text{(DERATE_Dim)}}$ is at 50%.
- When $V_{\text{(DERATE)}}$ is between $V_{\text{(DERATE_FULL)}}$ and $V_{\text{(DERATE_HALF)}}$, the output-current-derating ratio is negatively proportional to $V_{\text{(DERATE)}}$ with 32 steps. Current derating is rounded to the next-lower step. The output-current-derating ratio can be calculated using the following equations.

$$V_{\text{(DERATE_STEP)}} = \frac{V_{\text{(DERATE_HALF)}} - V_{\text{(DERATE_FULL)}}}{32} \quad (8)$$

$$k_{\text{(DERATE_Dim)}} = 100\% - \left(\frac{V_{\text{(DERATE)}} - V_{\text{(DERATE_FULL)}}}{V_{\text{(DERATE_STEP)}}} \right) \times \frac{50\%}{32} \quad (9)$$

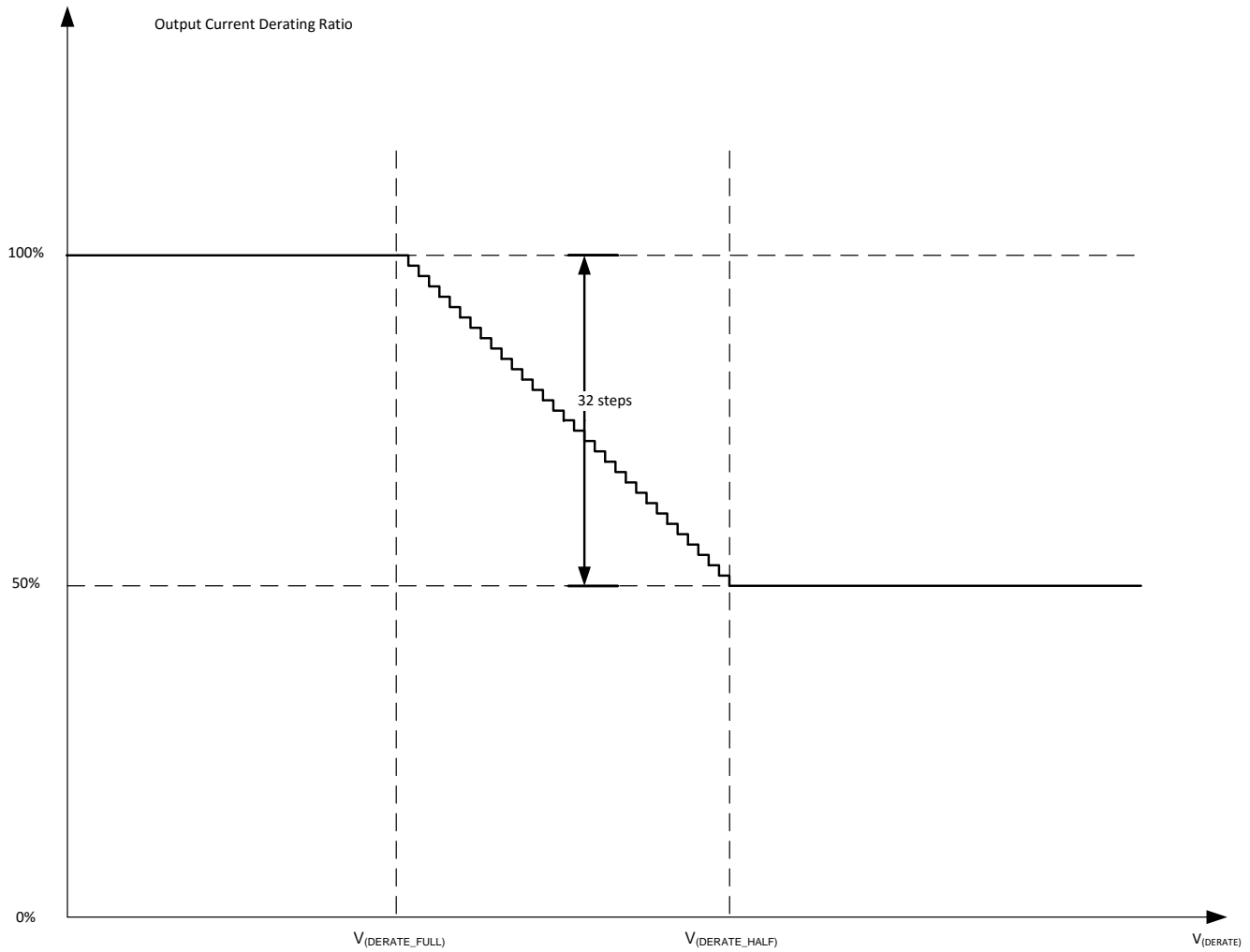

Copyright © 2017, Texas Instruments Incorporated

图 28. Output-Current Derating Profile

8.3.7 Diagnostics and Fault

The TPS92830-Q1 device provides advanced diagnostics and fault protection methods for automotive exterior lighting systems. The device is able to detect and protect from LED output short-to-GND as well as from LED output open-circuit scenarios. The device also supports a one-fails-all-fail fault bus that could flexibly fit different legislative requirements.

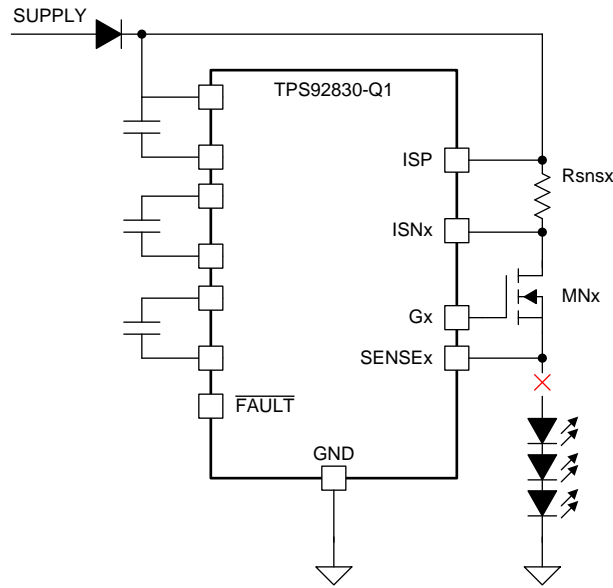

Copyright © 2017, Texas Instruments Incorporated

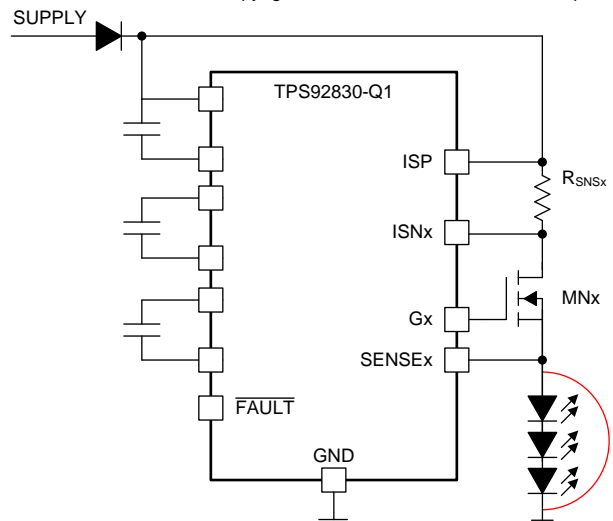

Copyright © 2017, Texas Instruments Incorporated

图 29. LED Open and Short Scenarios

8.3.7.1 LED Short-to-GND Detection

The TPS92830-Q1 device has channel-independent LED short-to-GND detection. Short-to-GND detection is only enabled during channel on-time. Once an LED short-to-GND failure is detected, the device turns off the faulty channel and retries automatically. If the auto-retry mechanism detects that the LED short-to-GND fault has been removed, the device resumes normal operation. section

The device monitors voltage $V_{(SENSEx)}$ and compares it with the internal reference voltage to detect short-to-GND failures. If the period during which $V_{(SENSEx)}$ falls below $V_{(SG_th_rising)}$ is longer than the deglitch time of $t_{(SG_deg)}$, the device asserts a short-to-GND fault on this channel. During the deglitch time period, if V_{SENSEx} rises above $V_{(SG_th_falling)}$, the timer is reset.

If a fault is detected, a constant-current source pulls the fault bus down. If \overline{FAULT} is low, all devices connected to the fault bus are off in the fault mode.

8.3.7.2 LED Short-to-GND Auto Retry

Once the channel has asserted a short-to-GND fault, it automatically retries periodically. In PWM mode, the device sources $I_{(\text{Retry_short})}$ through the SENSE_x pin to pull up the LED loads with a pulse duration of $t_{(\text{SG_retry_ON})}$. The device waits for $t_{(\text{SG_retry_OFF})}$ until the next retry pulse. Once auto retry detects that the short-to-GND fault is removed, the device resumes normal operation. During auto retry mode, the device ignores PWM inputs.

8.3.7.3 LED Open-Circuit Detection

The TPS92830-Q1 device has channel-independent LED open-circuit detection. Once an LED open-circuit failure is detected, the device turns off the faulty channel and retries automatically. If the retry mechanism detects that the LED open-circuit fault is removed, the device resumes normal operation.

The device monitors MOSFET dropout voltage differences between the ISN_x and SENSE_x pins. Voltage difference $V_{(\text{ISN}_x)} - V_{(\text{SENSE}_x)}$ is compared with internal reference voltage $V_{(\text{OPEN_th_rising})}$ to detect an LED open-circuit failure. If $V_{(\text{ISN}_x)} - V_{(\text{SENSE}_x)}$ falls below the $V_{(\text{OPEN_th_rising})}$ voltage and it stays there longer than the deglitch time of $t_{(\text{OPEN_deg})}$, the device asserts an open-load fault on this channel. During the deglitching time period, if $V_{(\text{ISN}_x)} - V_{(\text{SENSE}_x)}$ rises above $V_{(\text{OPEN_th_falling})}$, the deglitch timer is reset.

In normal operation, the N-channel MOSFET operates in the saturation region with a gate-source voltage close to its threshold voltage. In this case, the drain-source voltage of the N-channel MOSFET is typically much higher than open-circuit threshold $V_{(\text{OPEN_th_rising})}$. In the LED open-circuit condition, the N-channel MOSFET operates in the linear region with a gate-source voltage much higher than its threshold voltage. The N-channel MOSFET is fully on.

If a fault is detected, a constant-current source pulls the fault bus down. If the $\overline{\text{FAULT}}$ pin is low, all devices connected to the fault bus are off in the fault mode.

8.3.7.4 LED Open-Circuit Auto Retry

Once the channel has asserted an open-circuit fault, it automatically retries periodically. The device sources $I_{(\text{Retry_open})}$ through the SENSE_x pin to pull up the LED loads with a pulse duration of $t_{(\text{OPEN_retry_ON})}$. In PWM mode, the device waits for $t_{(\text{OPEN_retry_OFF})}$ until the next retry pulse. Once auto retry detects that the open-circuit fault has been removed, the device resumes normal operation. During auto retry mode, the device ignores PWM inputs. In the open-circuit scenario, the retry current cannot find a path to ground; thus, total current consumption does not increase.

8.3.7.5 Dropout-Mode Diagnostics

When the input voltage is not high enough to keep the external N-channel MOSFET in the constant-current saturation region, the TPS92830-Q1 device tries to regulate current by driving the external N-channel MOSFET in the linear region. This state is called the dropout mode, because voltage across the sense resistor is not able to reach the regulation threshold.

In dropout mode, LED open-circuit detection must be disabled via the DIAGEN input. Otherwise, the dropout mode would be treated as an LED open-circuit fault. The DIAGEN pin is used to avoid false diagnostics on an output channel due to low supply voltage.

When the DIAGEN voltage is low, the LED open-circuit detection is ignored. When the DIAGEN voltage is high, LED open-circuit detection resumes normal operation.

In dropout mode, the MOSFET is driven at maximum gate-source voltage to regulate current to the desired value. When the supply voltage increases, the MOSFET gate voltage is pulled down internally by a control loop. If the supply-voltage slew rate is fast, a high-current pulse can be observed on the LED for a short period of time. At the same time, the current-sense voltage may exceed the normal operating range and damage internal circuitry. A parallel diode or a current-limiting resistor less than 1 kΩ is recommended to clamp the voltage across the sensing resistor in the case of a large pulse current.

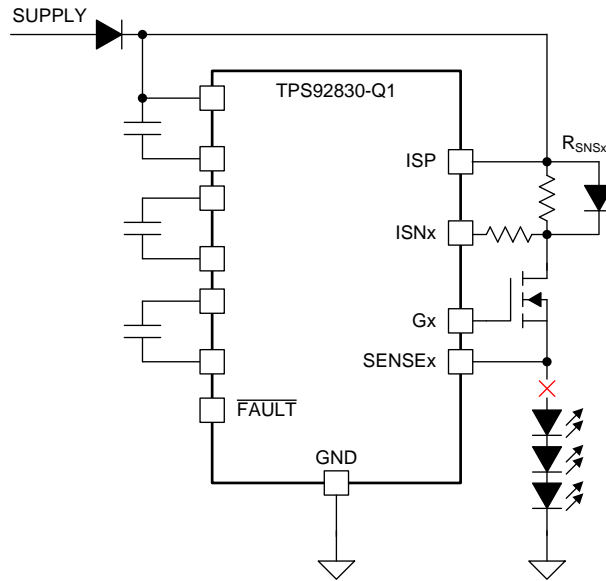

Copyright ©2017, Texas Instruments Incorporated

图 30. Resistor and Diode for Sense-Resistor Protection

8.3.7.6 Overtemperature Protection

The TPS92830-Q1 device monitors device junction temperature. When the junction temperature reaches the thermal shutdown threshold $T_{(TSD)}$, all outputs shut down and the charge pump also stops working. Once the junction temperature falls below $T_{(TSD)} - T_{(TSD_HYS)}$, the device resumes normal operation. During overtemperature protection, the \overline{FAULT} bus is pulled low.

8.3.7.7 \overline{FAULT} Bus Output With One-Fails-All-Fail

The TPS92830-Q1 device has a \overline{FAULT} bus for diagnostics output. It also supports a one-fails-all-fail function with other TPS92830-Q1, TPS9261x-Q1, TPS92630-Q1, or TPS92638-Q1 devices.

In normal operation, \overline{FAULT} is weakly pulled up by internal pullup current source $I_{(FAULT_pullup)}$ to a voltage higher than $V_{OH(FAULT)}$. If any fault scenario occurs, the \overline{FAULT} bus is strongly pulled low by internal pulldown current source $I_{(FAULT_pulldown)}$. Once $V_{(FAULT)}$ falls below $V_{IL(FAULT)}$, all outputs are shut down for protection. The faulty channel keeps retrying until the fault condition is removed. The charge pump is shut down, and current consumption is also reduced to $I_{(FAULT)}$ to save quiescent current.

If \overline{FAULT} is externally pulled up with a current higher than $I_{(FAULT_pulldown)}$, the one-fails-all-fail function is disabled and only the faulty channel is turned off. The charge pump remains operating normally, and the device is in normal operation mode. The \overline{FAULT} bus is able to support up to 15 pieces of TPS92830-Q1, TPS92630-Q1, TPS92638-Q1, or TPS9261x-Q1 devices.

8.3.7.8 Fault Table
表 3. Fault Table With DIAGEN = HIGH

FAULT TYPE	DETECTION MECHANISM	CHANNEL STATE	DEGLITCH TIME	FAULT BUS	FAULT HANDLING ROUTINE	FAULT RECOVERY
FAULT FLOATING						
LED open-circuit	$V_{ISN_x} - V_{SENSE_x} < V_{(OPEN_th_rising)}$	On	$t_{(OPEN_deg)}$	Constant-current pulldown	All channels turned off. Pulsed pullup retry of faulty channel.	Auto recover
LED short-to-GND	$V_{SENSE_x} < V_{(SG_th_rising)}$	On	$t_{(SG_deg)}$		All channels turned off. Pulsed pullup retry of faulty channel.	
LED short-to-battery	$V_{ISN_x} - V_{SENSE_x} < V_{(OPEN_th_rising)}$	On or off	$t_{(OPEN_deg)}$		All channels turned off. Faulty channel pulsed pullup retry of faulty channel.	
Overtemperature	$T_J > T_{(TSD)}$	On or off			All channels turned off.	
FAULT EXTERNALLY PULLED UP						
LED open-circuit	$V_{ISN_x} - V_{SENSE_x} < V_{(OPEN_th_rising)}$	On	$t_{(OPEN_deg)}$	Externally pulled up with internal constant-current pulldown	Only faulty channel turned off. Pulsed pullup retry of faulty channel.	Auto recover
LED short-to-GND	$V_{SENSE_x} < V_{(SG_th_rising)}$	On	$t_{(SG_deg)}$		Only faulty channel turned off. Pulsed pullup retry of faulty channel.	
LED short-to-battery	$V_{ISN_x} - V_{SENSE_x} < V_{(OPEN_th_rising)}$	On or off	$t_{(OPEN_deg)}$		Only faulty channel turned off. Pulsed pullup retry of faulty channel.	
Overtemperature	$T_J > T_{(TSD)}$	On or off			All channels turned off.	
FAULT EXTERNALLY PULLED DOWN						
All outputs disabled						

表 4. Fault Table With DIAGEN = LOW

FAULT TYPE	DETECTION MECHANISM	CHANNEL STATE	DEGLITCH TIME	FAULT BUS	FAULT HANDLING ROUTINE	FAULT RECOVERY
FAULT FLOATING						
LED open-circuit	Ignored	Ignored	Ignored	Ignored	Ignored	Ignored
LED short-to-GND	$V_{(SENSEx)} < V_{(SG_th_rising)}$	On	$t_{(SG_deg)}$	Constant current pull down	All channels turned off. Pulsed pullup retry of faulty channel.	Auto recover
LED short-to-battery	Ignored	Ignored	Ignored	Ignored	Ignored	Ignored
Overtemperature	$T_J > T_{(TSD)}$	On or off		Constant current pull down	All channels turned off.	Auto recover
FAULT EXTERNALLY PULLED UP						
LED open-circuit	Ignored	Ignored	Ignored	Ignored	Ignored	Ignored
LED short-to-GND	$V_{(SENSEx)} < V_{(SG_th_rising)}$	On	$t_{(SG_deg)}$	Externally pulled up with internal constant current pulled down	Only faulty channel turned off. Pulsed pullup retry of faulty channel.	Auto recover
LED short-to-battery	Ignored	Ignored	Ignored	Ignored	Ignored	Ignored
Overtemperature	$T_J > T_{(TSD)}$	On or off		Externally pulled up with internal constant current pulled down	All channels turned off.	Auto recover
FAULT EXTERNALLY PULLED LOW						
All outputs disabled	All outputs disabled	All outputs disabled	All outputs disabled	All outputs disabled	All outputs disabled	All outputs disabled

8.4 Device Functional Modes

8.4.1 Undervoltage Lockout, $V_{(IN)} < V_{(UVLO)}$

When the device is in undervoltage lockout mode, the TPS92830-Q1 device disables all functions until the supply rises above the UVLO-rising threshold. The device pulls down the Gx outputs. Other outputs are in the high-impedance state.

8.4.2 Normal Operation ($V_{(IN)} \geq 4.5\text{ V}$, $V_{(IN)} > V_{(LED)} + 0.5\text{ V}$)

The device drives an LED string in normal operation. A 0.5-V minimal dropout voltage is typically more than enough to maintain LED current regulation.

8.4.3 Low-Voltage Dropout

When the device drives an LED string in low-dropout mode, even with the MOSFETs fully turned on the output current may not reach target value. The device reports an LED open-circuit failure if DIAGEN is HIGH.

8.4.4 Fault Mode (Fault Is Detected)

When the device detects an open or shorted LED, the device tries to pull down the $\overline{\text{FAULT}}$ pin with a constant current. If the fault bus is pulled down, the device switches to fault mode and consumes a fault current of $I_{(FAULT)}$.

9 Application and Implementation

注

Information in the following applications sections is not part of the TI component specification, and TI does not warrant its accuracy or completeness. TI's customers are responsible for determining suitability of components for their purposes. Customers should validate and test their design implementation to confirm system functionality.

9.1 Application Information

In automotive applications, linear LED drivers are preferable for various applications, especially exterior lighting, for their simplicity and electromagnetic compatibility. This section provides a few examples to show the design process for different features.

9.2 Typical Applications

9.2.1 Typical Application for Automotive Exterior Lighting With One-Fails-All-Fail

Various functions of exterior lighting may use the following circuit. Here is a typical application circuit for a turn indicator. A TPS92830-Q1 drives a total of nine LEDs with 3s3p configuration at 300 mA each.



图 31. TPS92830-Q1 Typical Application Circuit For Automotive Exterior Lighting

9.2.1.1 Design Requirements

With the wide range of battery voltages in modern automotive systems, it is a common requirement among car OEMs to turn LEDs off when the battery voltage is below the minimal voltage threshold, for example, 6 V.

When the battery voltage is between 6 V and 9 V, LEDs may not achieve full brightness due to low input voltage. Although a linear LED driver may drive in low-dropout mode, it is required not to treat the low-dropout mode as an open-circuit fault and to report a false error.

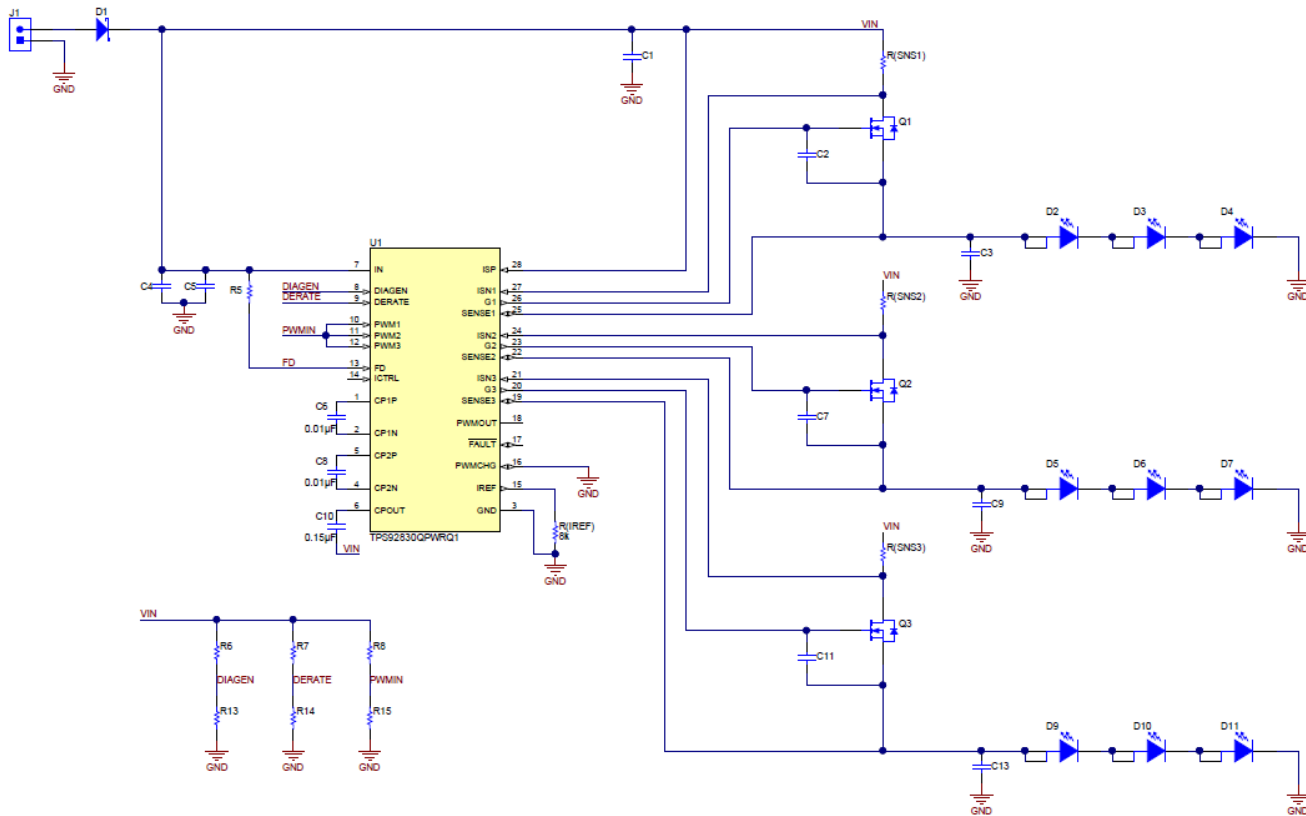
Typical Applications (接下页)

When battery voltage ranges between 9 V and 16 V, the LED driver works in normal mode with the one-fails-all-fail feature. If any LED strings fail with an open circuit or short circuit, the TPS92830-Q1 device pulls down the fault bus. All devices connected to the same fault bus turn off their outputs.

When the battery voltage is above 18 V, the TPS92830-Q1 device is able to detect the overvoltage and derate the output current to reduce the power dissipation of the MOSFETs and prevent thermal damage.

9.2.1.2 Detailed Design Procedure

Fixed Parameters

- Charge pump flying capacitor C6 = 10 nF
- Charge pump flying capacitor C8 = 10 nF
- $R_{(IREF)} = 8 \text{ k}\Omega$
- Charge pump storage capacitor C10 = 150 nF

Current Setting

- $I_{(LED)} = 300 \text{ mA}$
- $R_{(SNS)} = V_{(CS_REG)} / I_{(LED)} = 0.983 \Omega$

PWM Threshold Setting

- PWM enables when $V_{(IN)} > 6 \text{ V}$
- $K_{(RES_PWM)} = V_{IH(PWMx, \text{max})} / 6 \text{ V}$
- $K_{(RES_PWM)} = R15 / (R15 + R8)$
- Set $R15 = 20 \text{ k}\Omega$, $R8 = 76 \text{ k}\Omega$

DiagEN Setting (Enables LED-Open Detection When $V_{(IN)} > 9 \text{ V}$)

- $K_{(RES_DiagEN)} = V_{IH(DIAGEN, \text{max})} / 9 \text{ V}$
- $K_{(RES_DiagEn)} = R13 / (R6 + R13)$
- Set $R13 = 10 \text{ k}\Omega$, $R6 = 62 \text{ k}\Omega$ DiagEN setting

DERATE Setting (Reduces Current Output When $V_{(IN)} > 18 \text{ V}$)

- $K_{(RES_DERATE)} = V_{(DERATE_FULL, \text{min})} / 18 \text{ V}$
- $K_{(RES_DERATE)} = R7 / (R7 + R14)$
- Set $R7 = 10 \text{ k}\Omega$, $R14 = 95 \text{ k}\Omega$

To deliver 300 mA with a single MOSFET package, the designer must consider the maximum thermal-dissipation condition. The power dissipation of a MOSFET is usually at its peak when input voltage is at 16 V in a full-brightness condition. Assume the minimal LED forward voltage at 300 mA is 6 V.

$$P_{(MOSFET)} = I_{(LED)} \times (V_{(IN)} - V_{F(\text{Diode})} - V_{F(\text{LED}, \text{min})} - V_{(CS_REG)}) = 300\text{mA} \times (16 - 0.7 - 6 - 0.295) = 2.702\text{W} \quad (10)$$

MOSFET package and layout design must be considered to dissipate 2.702 W at maximum ambient temperature, usually 85°C.

The TPS92830 device can support a variety of N-channel MOSFETs in the markets. Adding a capacitor between the gate and source increases the loop phase margin. The recommended total capacitance at Gx is greater than 4 nF.

Typical Applications (接下页)

9.2.1.3 Application Curves

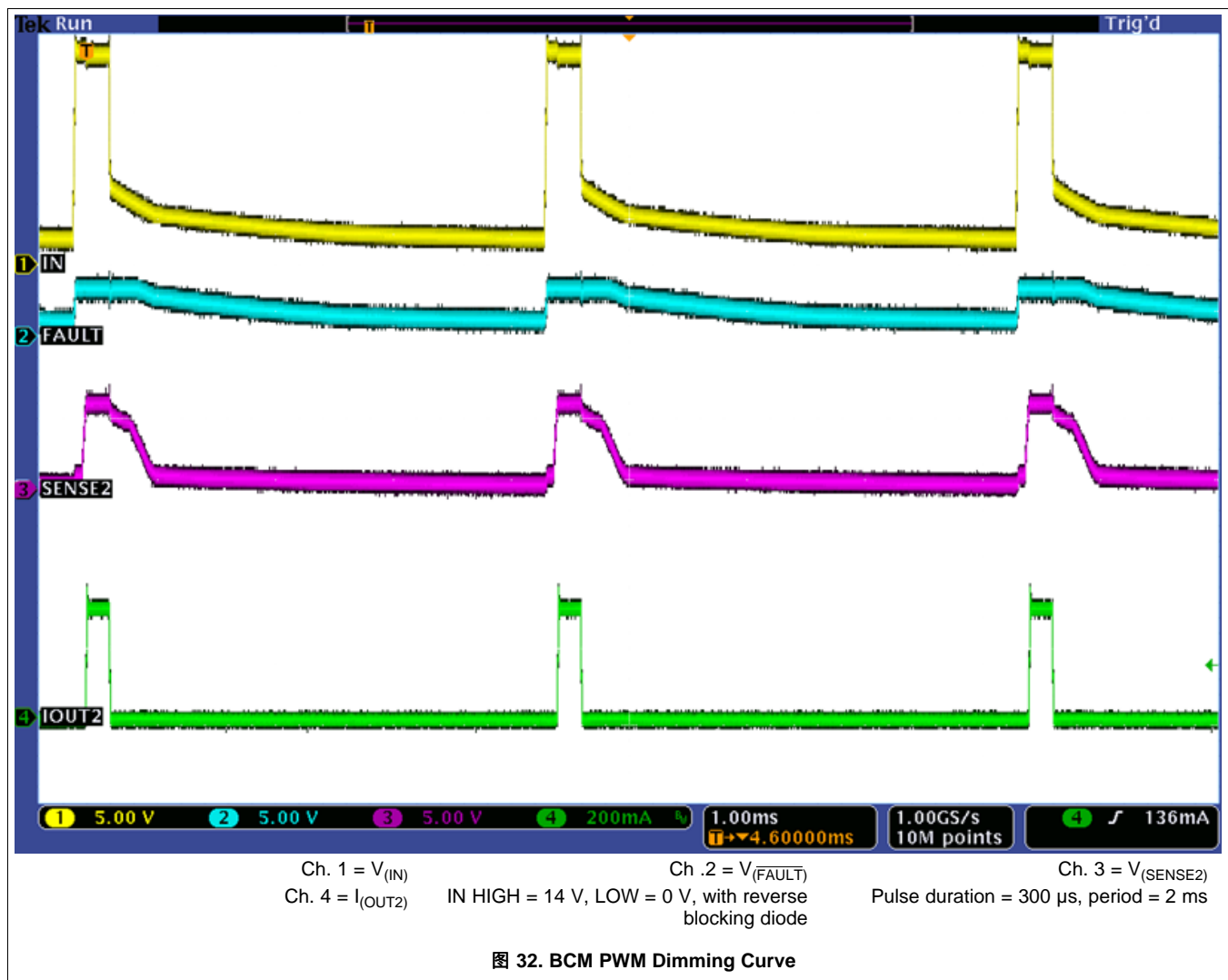

9.2.2 High-Precision Dual-Brightness PWM Generation

9.2.2.1 Dual-Brightness Application

Automotive lighting often reuses the same LEDs for different functions with different brightness, for example, daytime running lights (DRL) and position lights, or stop and tail lights. Analog dimming by changing the constant current may affect LED color temperature. PWM dimming could easily achieve the dimming ratio with the same color temperature.

The TPS92830-Q1 device provides a precision PWM generator with a synchronization PWMOUT output. Its integrated high-precision PWM generator ensures homogeneity across different devices.

Typical Applications (接下页)

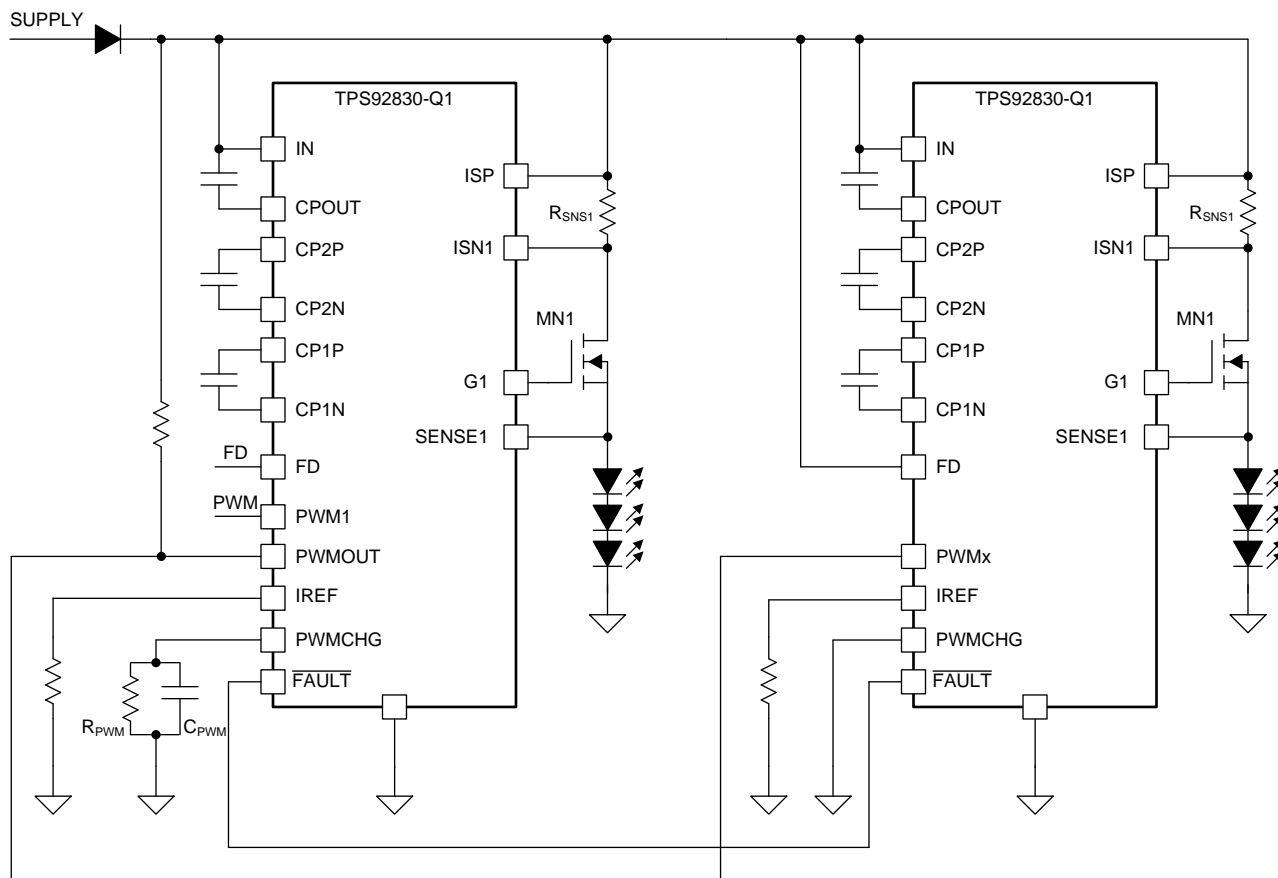

Copyright © 2017, Texas Instruments Incorporated

图 33. PWM Generator Master-Slave Configuration

9.2.2.2 Design Requirements

When full duty-cycle (FD) is HIGH, the output is at 100% duty cycle.

When full duty-cycle (FD) is LOW, the output is at 10% duty cycle and 250 Hz.

9.2.2.3 Detailed Design Procedure

PWM Equations

- $R_{PU} = 10\text{ k}\Omega$
- $C_{PWM} = 105.5\text{ nF}$
- $R_{PWM} = 55.5\text{ k}\Omega$

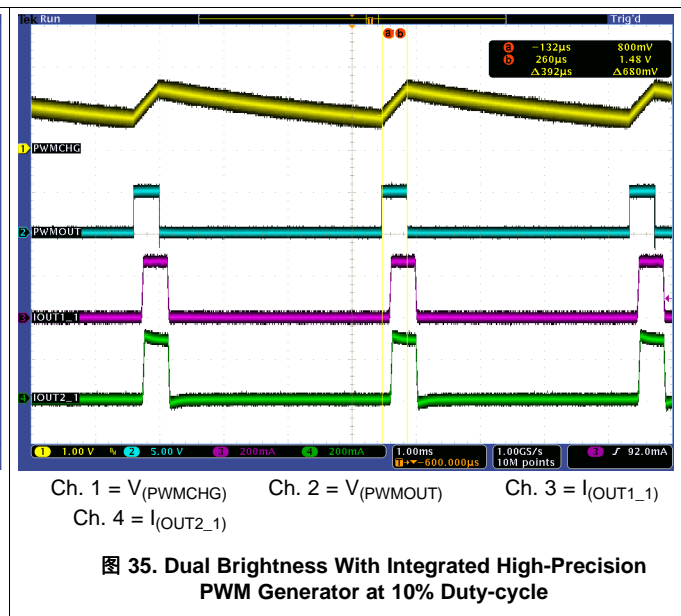
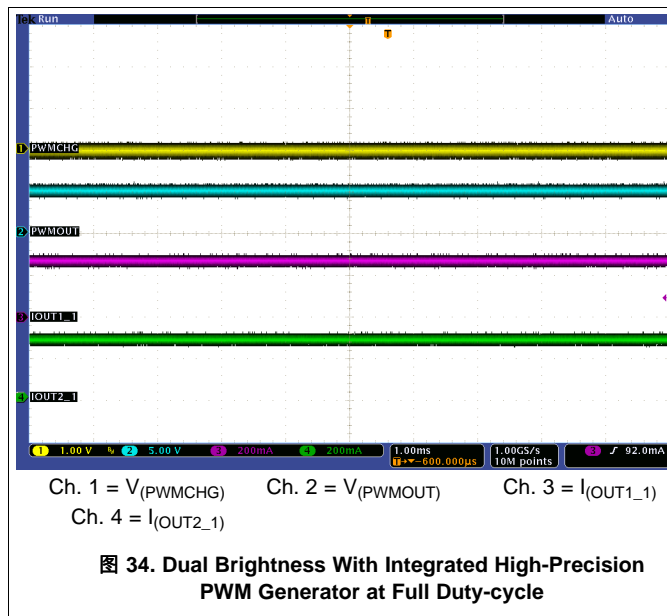
Typical Applications (接下页)
9.2.2.4 Application Curve

9.2.3 Driving High-Current LEDs With Parallel MOSFETs

Thermal performance is one key consideration in automotive exterior driving, especially for a linear LED driver. Due to large variations of automotive battery voltage, a linear LED driver must accommodate thermal dissipation with a worst-case scenario, which is high ambient temperature and high battery voltage.

LED driver thermal dissipation performance merely depends on the package and PCB thermal dissipation area. However, if the thermal dissipation performance of a single MOSFET is not able to support the required LED string current, multiple MOSFETs in parallel are able to dissipate heat for high-current applications.

When a MOSFET is in the saturation region as a current-control device, its current output strongly depends on its threshold. MOSFET threshold V_{th} can vary from one device to another. When MOSFETs are in parallel, even a small threshold mismatch could lead to imbalance of current distribution.

With an integrated charge pump, the TPS92830-Q1 device provides sufficient headroom even when the supply voltage is as low as 5 V. Thus adding ballast resistors between the N-channel MOSFET source and the LED string introduces negative feedback for each parallel MOSFET path to balance the current flows.

表 5. Thermal Measurement of Parallel MOSFETs

	WITHOUT CURRENT BALLAST Resistor	WITH 1-Ω BALLAST RESISTOR	WITH 3-Ω BALLAST RESISTOR
MOSFET1 Temperature (°C)	105.7	85.3	85.9
MOSFET2 Temperature (°C)	76.1	82.8	84.2
MOSFET3 Temperature (°C)	84.8	87.6	85.3

$V_{(IN)} = 16\text{ V}$, $I_{(Total)} = 964\text{ mA}$, $T_A = 25\text{ }^\circ\text{C}$.

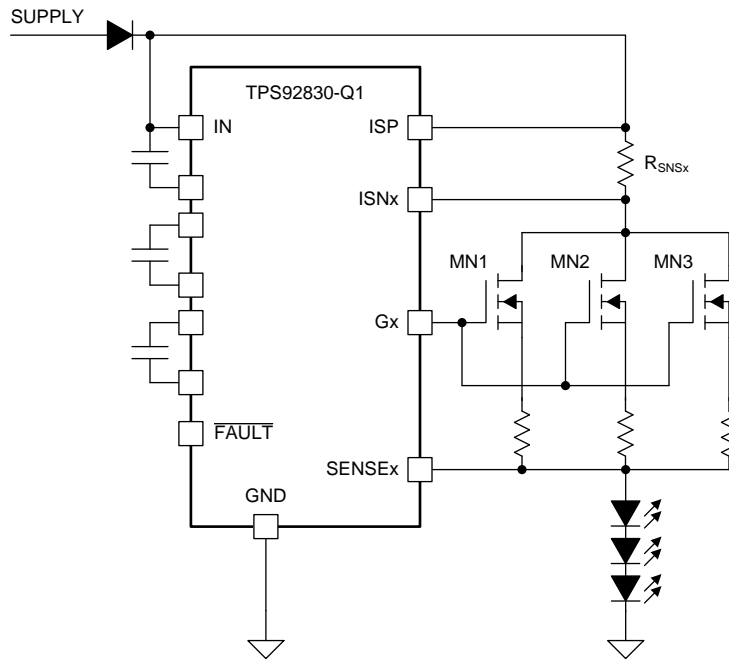

Copyright © 2017, Texas Instruments Incorporated

图 36. Parallel MOSFET Driving

9.2.3.1 Application Curves

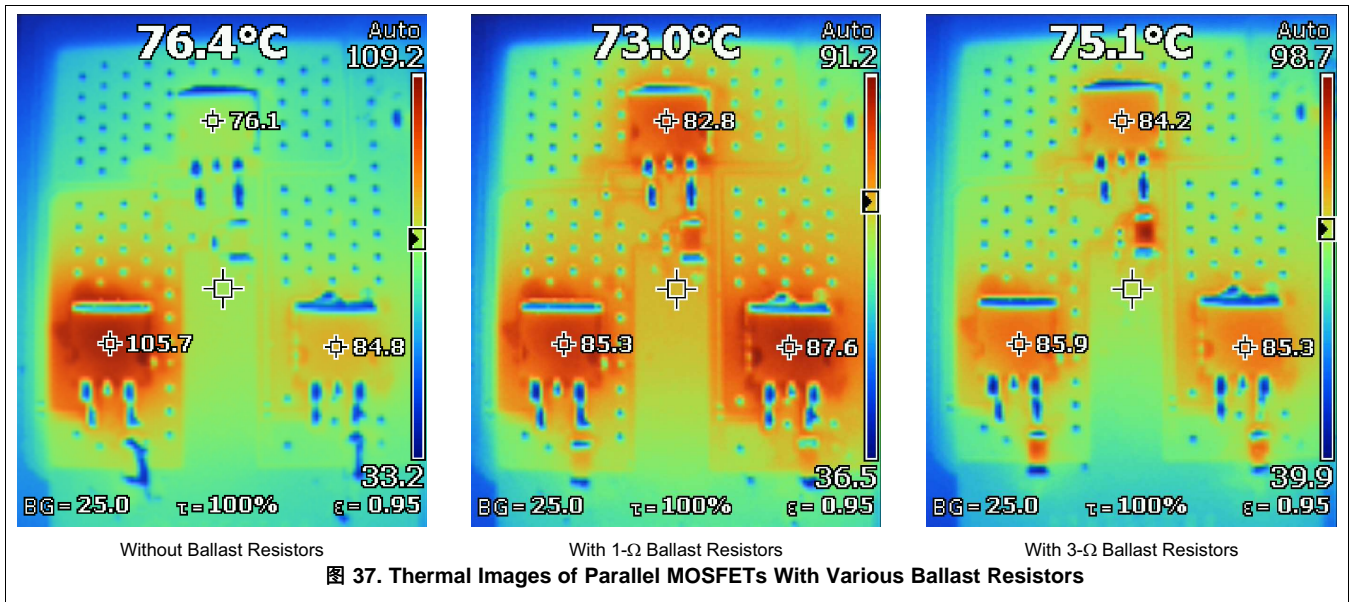

10 Layout

10.1 Layout Guidelines

The TPS92830-Q1 device relies on external MOSFETs to dissipate heat for high-current applications. To effectively dissipate heat on MOSFETs and LEDs, TI recommends to use 0.071-mm-thick (2-oz.) copper PCBs or metal-based boards. Make the thermal dissipation area with copper as large as possible. Place thermal vias on the thermal dissipation area to further improve the thermal dissipation capability. The current path starts from IN through the sense-resistors, MOSFETs, and LEDs to GND. Wide traces are helpful to reduce parasitic resistance along the current path as shown in the layout example below.

Place capacitors, especially charge pump capacitors, close to the device to make the current path as short as possible. TI suggests keeping the LED high-current ground path separate from device ground. TI also recommends kelvin-connection to the connector. The following layout example shows the recommended guidelines.

10.2 Layout Example

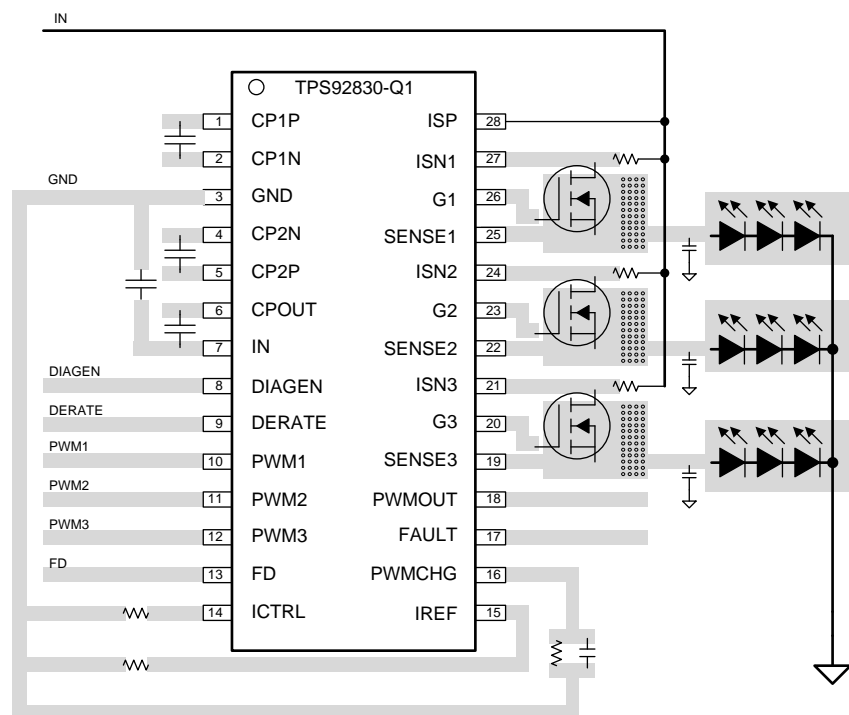

Copyright © 2017, Texas Instruments Incorporated

图 38. TPS92830-Q1 Example Layout Diagram

11 器件和文档支持

11.1 接收文档更新通知

要接收文档更新通知，请导航至TI.com 上的器件产品文件夹。单击右上角的通知我进行注册，即可每周接收产品信息更改摘要。

11.2 社区资源

下列链接提供到 TI 社区资源的连接。链接的内容由各个分销商“按照原样”提供。这些内容并不构成 TI 技术规范，并且不一定反映 TI 的观点；请参阅 TI 的《使用条款》。

TI E2E™ 在线社区 *TI 的工程师对工程师 (E2E) 社区*。此社区的创建目的在于促进工程师之间的协作。在 e2e.ti.com 中，您可以咨询问题、分享知识、拓展思路并与同行工程师一道帮助解决问题。

设计支持 *TI 参考设计支持* 可帮助您快速查找有帮助的 E2E 论坛、设计支持工具以及技术支持的联系信息。

11.3 商标

E2E is a trademark of Texas Instruments.

11.4 静电放电警告



这些装置包含有限的内置 ESD 保护。存储或装卸时，应将导线一起截短或将装置放置于导电泡棉中，以防止 MOS 门极遭受静电损伤。

11.5 Glossary

SLYZ022 — *TI Glossary*.

This glossary lists and explains terms, acronyms, and definitions.

12 机械、封装和可订购信息

以下页面包含机械、封装和可订购信息。这些信息是针对指定器件提供的最新数据。本数据随时可能发生变更并且不对本文档进行修订，恕不另行通知。要获得这份数据表的浏览器版本，请查阅左侧的导航窗格。

PACKAGING INFORMATION

Orderable Device	Status (1)	Package Type	Package Drawing	Pins	Package Qty	Eco Plan (2)	Lead finish/ Ball material (6)	MSL Peak Temp (3)	Op Temp (°C)	Device Marking (4/5)	Samples
TPS92830QPWRQ1	ACTIVE	TSSOP	PW	28	2000	RoHS & Green	NIPDAU	Level-3-260C-168 HR	-40 to 125	TPS92830	Samples

(1) The marketing status values are defined as follows:

ACTIVE: Product device recommended for new designs.

LIFEBUY: TI has announced that the device will be discontinued, and a lifetime-buy period is in effect.

NRND: Not recommended for new designs. Device is in production to support existing customers, but TI does not recommend using this part in a new design.

PREVIEW: Device has been announced but is not in production. Samples may or may not be available.

OBSOLETE: TI has discontinued the production of the device.

(2) **RoHS:** TI defines "RoHS" to mean semiconductor products that are compliant with the current EU RoHS requirements for all 10 RoHS substances, including the requirement that RoHS substance do not exceed 0.1% by weight in homogeneous materials. Where designed to be soldered at high temperatures, "RoHS" products are suitable for use in specified lead-free processes. TI may reference these types of products as "Pb-Free".

RoHS Exempt: TI defines "RoHS Exempt" to mean products that contain lead but are compliant with EU RoHS pursuant to a specific EU RoHS exemption.

Green: TI defines "Green" to mean the content of Chlorine (Cl) and Bromine (Br) based flame retardants meet JS709B low halogen requirements of <=1000ppm threshold. Antimony trioxide based flame retardants must also meet the <=1000ppm threshold requirement.

(3) MSL, Peak Temp. - The Moisture Sensitivity Level rating according to the JEDEC industry standard classifications, and peak solder temperature.

(4) There may be additional marking, which relates to the logo, the lot trace code information, or the environmental category on the device.

(5) Multiple Device Markings will be inside parentheses. Only one Device Marking contained in parentheses and separated by a "-" will appear on a device. If a line is indented then it is a continuation of the previous line and the two combined represent the entire Device Marking for that device.

(6) Lead finish/Ball material - Orderable Devices may have multiple material finish options. Finish options are separated by a vertical ruled line. Lead finish/Ball material values may wrap to two lines if the finish value exceeds the maximum column width.

Important Information and Disclaimer:The information provided on this page represents TI's knowledge and belief as of the date that it is provided. TI bases its knowledge and belief on information provided by third parties, and makes no representation or warranty as to the accuracy of such information. Efforts are underway to better integrate information from third parties. TI has taken and continues to take reasonable steps to provide representative and accurate information but may not have conducted destructive testing or chemical analysis on incoming materials and chemicals. TI and TI suppliers consider certain information to be proprietary, and thus CAS numbers and other limited information may not be available for release.

In no event shall TI's liability arising out of such information exceed the total purchase price of the TI part(s) at issue in this document sold by TI to Customer on an annual basis.

TAPE AND REEL INFORMATION



QUADRANT ASSIGNMENTS FOR PIN 1 ORIENTATION IN TAPE



*All dimensions are nominal

Device	Package Type	Package Drawing	Pins	SPQ	Reel Diameter (mm)	Reel Width W1 (mm)	A0 (mm)	B0 (mm)	K0 (mm)	P1 (mm)	W (mm)	Pin1 Quadrant
TPS92830QPWRQ1	TSSOP	PW	28	2000	330.0	16.4	6.9	10.2	1.8	12.0	16.0	Q1

TAPE AND REEL BOX DIMENSIONS



*All dimensions are nominal

Device	Package Type	Package Drawing	Pins	SPQ	Length (mm)	Width (mm)	Height (mm)
TPS92830QPWRQ1	TSSOP	PW	28	2000	350.0	350.0	43.0

MECHANICAL DATA

PW (R-PDSO-G28)

PLASTIC SMALL OUTLINE

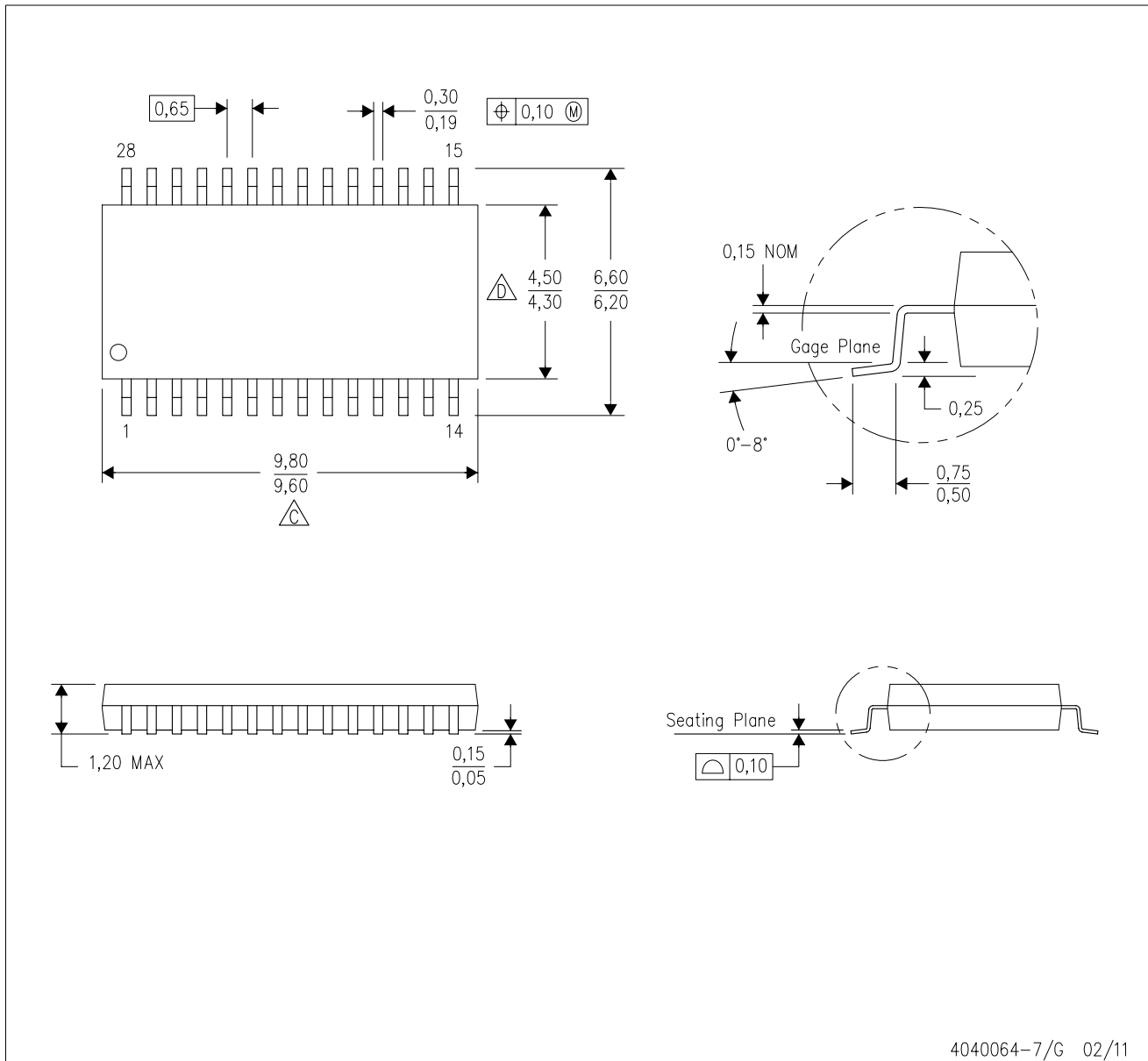

4040064-7/G 02/11

- NOTES:
- A. All linear dimensions are in millimeters. Dimensioning and tolerancing per ASME Y14.5M-1994.
 - B. This drawing is subject to change without notice.
 - C. Body length does not include mold flash, protrusions, or gate burrs. Mold flash, protrusions, or gate burrs shall not exceed 0,15 each side.
 - D. Body width does not include interlead flash. Interlead flash shall not exceed 0,25 each side.
 - E. Falls within JEDEC MO-153

PW (R-PDSO-G28)

PLASTIC SMALL OUTLINE

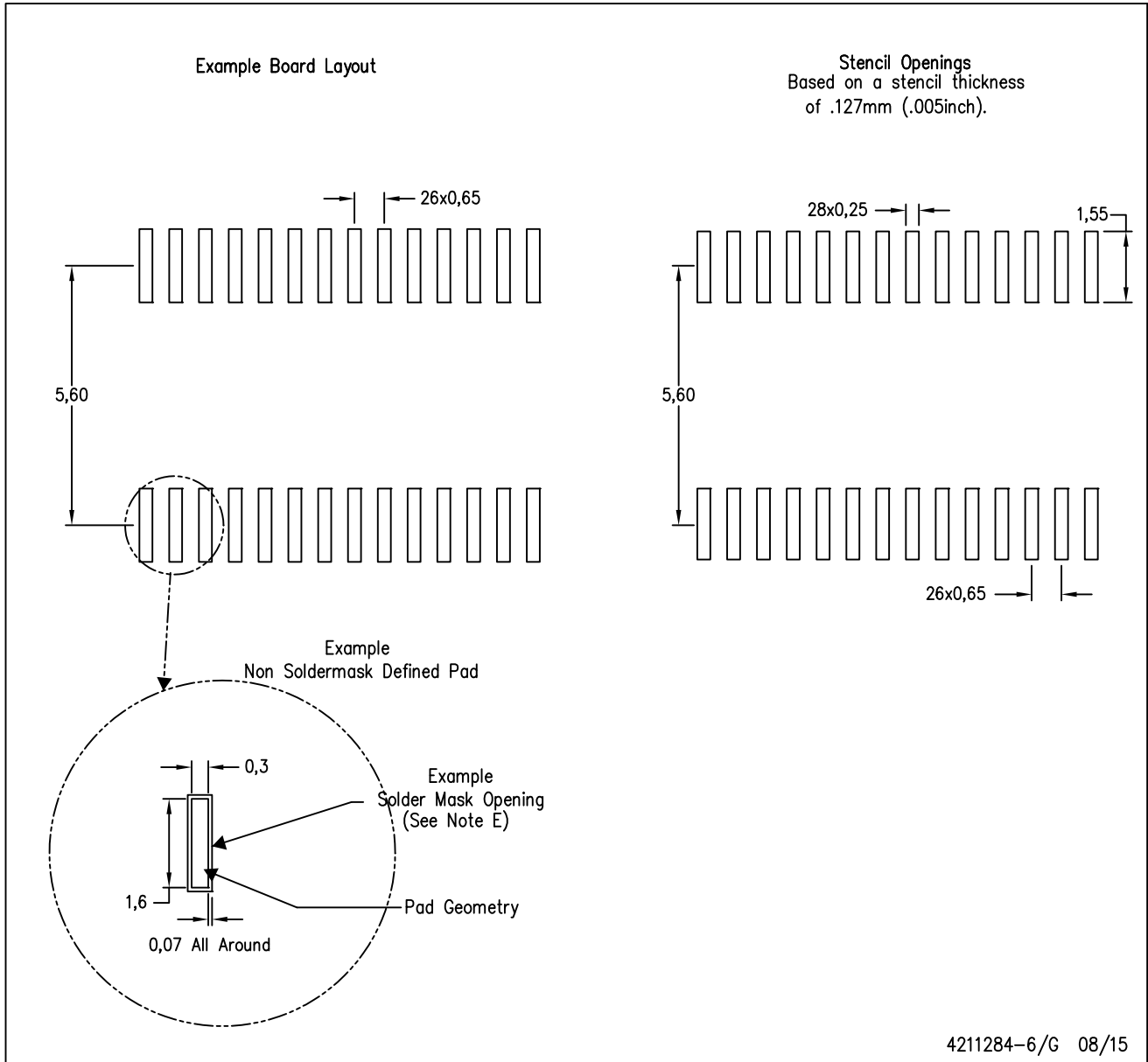

- NOTES:
- A. All linear dimensions are in millimeters.
 - B. This drawing is subject to change without notice.
 - C. Publication IPC-7351 is recommended for alternate design.
 - D. Laser cutting apertures with trapezoidal walls and also rounding corners will offer better paste release. Customers should contact their board assembly site for stencil design recommendations. Refer to IPC-7525 for other stencil recommendations.
 - E. Customers should contact their board fabrication site for solder mask tolerances between and around signal pads.

重要声明和免责声明

TI 均以“原样”提供技术性及其可靠性数据（包括数据表）、设计资源（包括参考设计）、应用或其他设计建议、网络工具、安全信息和其他资源，不保证其中不含任何瑕疵，且不做任何明示或暗示的担保，包括但不限于对适销性、适合某特定用途或不侵犯任何第三方知识产权的暗示担保。

所述资源可供专业开发人员应用TI 产品进行设计使用。您将对以下行为独自承担全部责任：(1) 针对您的应用选择合适的TI 产品；(2) 设计、验证并测试您的应用；(3) 确保您的应用满足相应标准以及任何其他安全、安保或其他要求。所述资源如有变更，恕不另行通知。TI 对您使用所述资源的授权仅限于开发资源所涉及TI 产品的相关应用。除此之外不得复制或展示所述资源，也不提供其它TI 或任何第三方的知识产权授权许可。如因使用所述资源而产生任何索赔、赔偿、成本、损失及债务等，TI 对此概不负责，并且您须赔偿由此对TI 及其代表造成的损害。

TI 所提供产品均受TI 的销售条款 (<http://www.ti.com.cn/zh-cn/legal/termsofsale.html>) 以及ti.com.cn上或随附TI产品提供的其他可适用条款的约束。TI提供所述资源并不扩展或以其他方式更改TI 针对TI 产品所发布的可适用的担保范围或担保免责声明。

邮寄地址：上海市浦东新区世纪大道 1568 号中建大厦 32 楼，邮政编码：200122

Copyright © 2020 德州仪器半导体技术（上海）有限公司