

## UCC28251 具有预偏置操作的高级 PWM 控制器

### 1 特性

- 预偏置启动
- 具有可编程延迟的同步整流器控制输出（包括零延迟支持）
- 具有输入电压前馈的电压模式控制或电流模式控制
- 初级侧或次级侧控制
- 3.3V, 1.5% 高精度基准输出
- 较低的最小运行频率
- 具有已匹配占空比输出的 1% 高精度逐周期过流保护
- 可编程软启动和断续重启定时器
- 散热增强型 4mm x 4mm 超薄四方扁平无引线 (VQFN)-20 封装和 20 引脚薄型小外形尺寸 (TSSOP) 封装

### 2 应用

- 半桥、全桥、交错正激和推挽隔离式转换器
- 电信和数据通信电源
- 无线基站电源
- 服务器电源
- 工业电源系统

简单应用图（400V 输入 DC 至 DC 转换器）

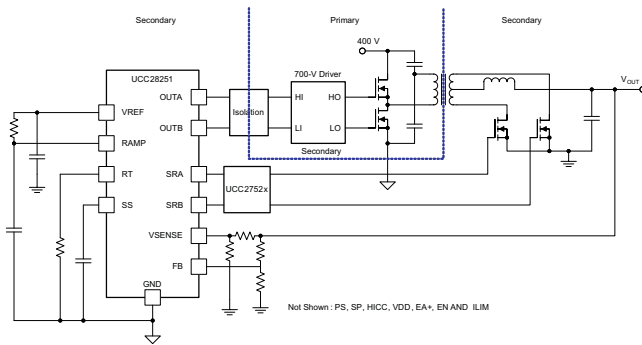

### 3 说明

UCC28251 PWM 控制器专为对预偏置启动要求严格的高功率密度应用而设计。UCC28251 的集成同步整流器控制输出针对高效和高性能拓扑结构，诸如半桥、全桥、交错正激和推挽结构。与 UCC28251 一同使用的 UCC27210 半桥驱动器和 UCC2752x MOSFET 驱动器提供一个完整的电源转换器解决方案。

UCC28251 是 UCC28250 PWM 控制器的功能性变体。UCC28251 在很大程度上保留了 UCC28250 的基本功能，同时经过设计增强了在离线式 400V 输入 DC-DC 应用和 48V 输入全桥或半桥应用中的性能。

器件信息(1)

器件型号	封装	封装尺寸 (标称值)
UCC28251	薄型小外形尺寸封装 (TSSOP) (20)	6.50mm x 4.40mm
	VQFN (20)	4.00mm x 4.00mm

(1) 如需了解所有可用封装，请见数据表末尾的可订购产品附录。

简单应用图（48V 输入 DC 至 DC 转换器）

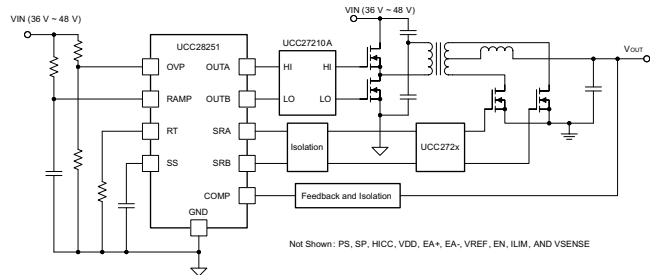

## 目录

1 特性 .....	1	8.3 Feature Description .....	14
2 应用 .....	1	8.4 Device Functional Modes .....	28
3 说明 .....	1	<b>9 Application and Implementation .....</b>	<b>29</b>
4 修订历史记录 .....	2	9.1 Application Information .....	29
5 说明 (续) .....	4	9.2 Typical Applications .....	35
<b>6 Pin Configuration and Functions .....</b>	<b>4</b>	<b>10 Power Supply Recommendations .....</b>	<b>43</b>
<b>7 Specifications .....</b>	<b>5</b>	<b>11 Layout .....</b>	<b>43</b>
7.1 Absolute Maximum Ratings .....	5	11.1 Layout Guidelines .....	43
7.2 ESD Ratings .....	5	11.2 Layout Example .....	44
7.3 Recommended Operating Conditions .....	5	11.3 Thermal Protection .....	44
7.4 Thermal Information .....	6	<b>12 器件和文档支持 .....</b>	<b>45</b>
7.5 Electrical Characteristics .....	6	12.1 文档支持 .....	45
7.6 Typical Characteristics .....	9	12.2 商标 .....	45
<b>8 Detailed Description .....</b>	<b>13</b>	12.3 静电放电警告 .....	45
8.1 Overview .....	13	12.4 Glossary .....	45
8.2 Functional Block Diagram .....	14	<b>13 机械、封装和可订购信息 .....</b>	<b>45</b>

## 4 修订历史记录

注：之前版本的页码可能与当前版本有所不同。

### Changes from Revision D (April 2013) to Revision E Page

• 已添加 引脚配置和功能部分, ESD 额定值表, 特性描述部分、器件功能模式、应用和实施部分、电源相关建议部分、布局部分、器件和文档支持部分以及机械、封装和可订购信息部分 .....	1
---	---

### Changes from Revision C (April, 2013) to Revision D Page

• Added VREF value for EN (Enable Pin) pin description. ....	15
• Changed <a href="#">Equation 3</a> . ....	17
• Changed <a href="#">Figure 27</a> . ....	19
• Changed <a href="#">Figure 28</a> . ....	20
• Changed <a href="#">Equation 4</a> . ....	20
• Changed Current Limit Circuit diagram. ....	25
• Changed UCC28251 Set Up for Peak Current Mode Control diagram. ....	33
• Changed <a href="#">Equation 28</a> . ....	37

### Changes from Revision B (March 2013) to Revision C Page

• Changed Operating junction temperature range from (-40 to 125) to (125 to 150). ....	5
• Added UCC28251PW Current Sense data. ....	7
• Changed Functional Block Diagram .....	14

**Changes from Revision A (February 2013) to Revision B**
**Page**

• Added Start threshold electrical characteristics.....	6
• Added Input offset electrical characteristics.....	6
• Added Primary off to secondary on dead time electrical characteristics.....	8
• Added Secondary off to primary on dead time electrical characteristics.....	8
• Added note, "The minimum value for $R_{PS}/R_{SP}$ is 5 k $\Omega$ and the maximum value is 250 k $\Omega$ ." in two places.....	19

**Changes from Original (February 2013) to Revision A**
**Page**

• Added <a href="#">Figure 24</a> , Oscillator Frequency $F_{OSC}$ vs External Resistance of RT at $T_{D(ps)} = 40$ ns and 100 ns.....	17
--	----

## 5 说明 (续)

在所有输出条件下，外部可编程软启动与内部预偏置启动电路的结合使用均可以使控制器逐渐到达稳态操作点。UCC28251 可针对初级或次级侧控制进行配置，并且可执行电压或电流模式控制。

振荡器的运行频率高达 1.8 MHz，并可与一个外部时钟同步。输入电压前馈、逐周期电流限制和一个可编程断续定时器可以使该系统保持在一个安全运行范围内。可执行输入电压、输出电压和温度保护。可独立设定初级侧开关和次级侧同步整流器之间的死区时间。

## 6 Pin Configuration and Functions

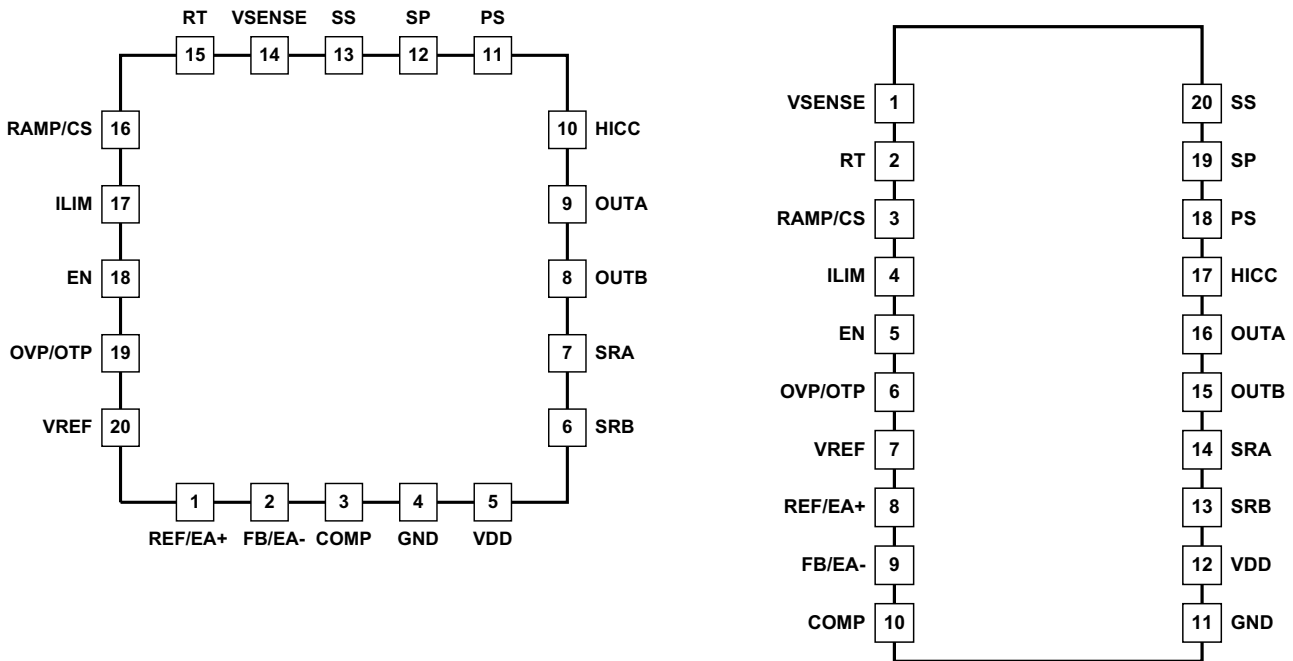

### Pin Functions

PIN			I/O	DESCRIPTION
QFN-20	PW-20	NAME		
5	12	VDD	I	Bias supply input.
20	7	VREF	O	3.3-V reference output.
18	5	EN	I	Device enable and disable.
15	2	RT	I	Oscillator frequency set or synchronous clock input.
12	19	SP	I	Synchronous rectifier off to primary on dead-time set .
11	18	PS	I	Primary off to synchronous rectifier on dead-time set .
16	3	RAMP/CS	I	PWM ramp input (for voltage mode control) or current sense input (for current mode control).
1	8	REF/EA+	I	Error amplifier non-inverting input.
2	9	FB/EA-	I	Error amplifier inverting input.
3	10	COMP	I/O	Error amplifier output.
14	1	VSENSE	I	Output voltage sensing for pre-bias control.
13	20	SS	I/O	Soft-start programming.
17	4	ILIM	I	Current sense for cycle-by-cycle over-current protection.
10	17	HICC	I	Cycle-by-cycle current limit time delay and Hiccup time setting.
19	6	OVP/OTP	I	Over voltage and over temperature protection pin.
9	16	OUTA	O	0.2-A sink/source primary switching output.
8	15	OUTB	O	0.2-A sink/source primary switching output.

### Pin Functions (continued)

PIN			I/O	DESCRIPTION
QFN-20	PW-20	NAME		
7	14	SRA	O	0.2-A sink/source synchronous rectifier output.
6	13	SRB	O	0.2-A sink/source synchronous rectifier output.
4	11	GND	I	Ground.

## 7 Specifications

### 7.1 Absolute Maximum Ratings

over operating free-air temperature range<sup>(1)(2)</sup> (unless otherwise noted)

		MIN	MAX	UNIT
VDD <sup>(3)</sup>	Input supply voltage	-0.3	20	V
	OUTA, OUTB, SRA and SRB	-0.3	VDD + 0.3	
	COMP	-0.3	VREF + 0.3	
	Input voltages on SS and EN	-0.3	5.5	
	Input voltages on RT, PS, SP, ILIM, OVP, HICC, VSENSE, EA+ and EA-	-0.3	3.6	
	Input voltage on RAMP/CS	-0.3	4.3	
	Output voltage on VREF	-0.3	3.6	
	Lead temperature (soldering 10 sec) PW package		300	°C
T <sub>stg</sub>	Storage temperature	-65	150	°C

- Stresses beyond those listed under Absolute Maximum Ratings may cause permanent damage to the device. These are stress ratings only, and functional operation of the device at these or any other conditions beyond those indicated under *Recommended Operating Conditions* is not implied. Exposure to absolute-maximum-rated conditions for extended periods may affect device reliability.
- These devices are sensitive to electrostatic discharge; follow proper device handling procedures.
- All voltages are with respect to GND unless otherwise noted. Currents are positive into, negative out of the specified pin. See Packaging Section of the datasheet for thermal limitations and considerations of packages.

### 7.2 ESD Ratings

		VALUE	UNIT
V <sub>(ESD)</sub>	Electrostatic discharge		V
	Human-body model (HBM), per ANSI/ESDA/JEDEC JS-001 <sup>(1)</sup>	±3000	
	Charged-device model (CDM), per JEDEC specification JESD22-C101 <sup>(2)</sup>	±2000	

- JEDEC document JEP155 states that 500-V HBM allows safe manufacturing with a standard ESD control process.
- JEDEC document JEP157 states that 250-V CDM allows safe manufacturing with a standard ESD control process.

### 7.3 Recommended Operating Conditions

over operating free-air temperature range (unless otherwise noted)

	MIN	NOM	MAX	UNIT
Supply voltage range, V <sub>DD</sub>	4.7	12	17	V
Supply bypass capacitor, C <sub>VDD</sub>	1			μF
VREF bypass capacitor	0.47		2.20	
Error amplifier input common mode range (REF/EA+, FB/EA-)	0		3.0	V
VSENSE input voltage range	0		3.3	
RT resistor range	12.5		200	kΩ
PS, SP resistor range	5		250	
RAMP/CS voltage range	0		2.3	V
Operating junction temperature range	-40		150	°C

## 7.4 Thermal Information

THERMAL METRIC <sup>(1)</sup>		UCC28251		UNIT
		RGP	PW	
		20 PINS	20 PINS	
$R_{\theta JA}$	Junction-to-ambient thermal resistance	126 with hot spot, 104 without hot spot	60.3 with hot spot, 39.3 without hot spot	°C/W
$R_{\theta JC(top)}$	Junction-to-case (top) thermal resistance	N/A	31.5	
$R_{\theta JB}$	Junction-to-board thermal resistance	N/A	55.8	
$R_{\theta JC(bot)}$	Junction-to-case (bottom) thermal resistance	0.8	N/A	

(1) For more information about traditional and new thermal metrics, see the *IC Package Thermal Metrics* application report, [SPRA953](#).

## 7.5 Electrical Characteristics<sup>(1)</sup>

VDD = 12 V, 1- $\mu$ F capacitor from VDD and VREF to GND,  $T_A = T_J = -40^\circ\text{C}$  to  $125^\circ\text{C}$ ,  $R_T = 75\text{ k}\Omega$  connected to ground to set  $F_{SW} = 100\text{ kHz}$  (unless otherwise noted).

PARAMETER		TEST CONDITIONS	MIN	TYP	MAX	UNIT
<b>SUPPLY CURRENTS</b>						
$I_{DD(off)}$	Startup current	VDD = 3.6 V		150	275	$\mu\text{A}$
$I_{DD}$	Operating supply current	100-pF capacitor on OUTA, OUTB, SRA and SRB	1.2	2.0	2.5	mA
$I_{DD(dis)}$	Standby current	EN = 0 V	250	425	600	$\mu\text{A}$
<b>UNDERVOLTAGE LOCKOUT</b>						
$V_{UVLOR}$	Start threshold		4.00	4.30	4.65	V
$V_{UVLOF}$	Minimum operating voltage after start		3.8	4.1	4.4	
	Hysteresis		0.15	0.20	0.25	
<b>SOFT-START</b>						
$I_{SS}$	Soft-start charge current	$V_{SS} = 0\text{ V}$	26	28	30	$\mu\text{A}$
$V_{SS(max)}$	Clamp voltage		3.3	3.6	4.0	V
<b>ENABLE<sup>(2)</sup></b>						
	Trigger threshold		1.5	2.0	2.25	V
	Minimum pulse width for pulse enable		3.2			$\mu\text{s}$
<b>ERROR AMPLIFIER</b>						
	High-level COMP voltage		2.8	3		V
	Low-level COMP voltage			0.3	0.4	
	Input offset		-16.2		18.0	mV
	Open loop gain		70	100		dB
$I_{COMP(snk)}$	COMP sink current		3.0	6.5	9.0	mA
$I_{COMP(src)}$	COMP source current		2.0	4.5	8.0	

(1) Typical values for  $T_A = 25^\circ\text{C}$ .

(2) Refer to EN pin description.

**Electrical Characteristics<sup>(1)</sup> (continued)**

V<sub>DD</sub> = 12 V, 1- $\mu$ F capacitor from V<sub>DD</sub> and V<sub>REF</sub> to GND, T<sub>A</sub> = T<sub>J</sub> = -40°C to 125°C, R<sub>T</sub> = 75 k $\Omega$  connected to ground to set F<sub>SW</sub> = 100 kHz (unless otherwise noted).

PARAMETER		TEST CONDITIONS	MIN	TYP	MAX	UNIT
<b>OSCILLATOR</b>						
F <sub>SW(nom)</sub>	Nominal switching frequency at OUTA or OUTB set by RT resistor	R <sub>T</sub> /S <sub>YNC</sub> = 75 k $\Omega$ , R <sub>SP</sub> = 20 k $\Omega$	90	98	106	kHz
F <sub>SW(min_sync)</sub>	Minimum switching frequency at OUTA or OUTB set by external sync frequency	f <sub>RT/SYNC</sub> = 50 kHz		42		
F <sub>SW(max_sync)</sub>	Maximum switching frequency at OUTA or OUTB set by external sync frequency	f <sub>RT/SYNC</sub> = 2.5 MHz		945		
	External synchronization signal high		1			V
	External synchronization signal low				0.2	
<b>VOLTAGE REFERENCE</b>						
V <sub>VREF</sub>	Output voltage	V <sub>DD</sub> = from 7 V to 17 V, I <sub>VREF</sub> = 2 mA	3.17	3.25	3.33	V
		0 < I <sub>REF</sub> < 10 mA	3.17	3.25	3.33	
	Short circuit current	V <sub>REF</sub> = 3 V, T <sub>J</sub> = 25 °C	12	25	40	mA
<b>CURRENT SENSE, CYCLE-BY-CYCLE CURRENT LIMIT WITH HICCUP</b>						
V <sub>ILIM</sub>	ILIM cycle-by-cycle threshold		0.497	0.505	0.513	V
T <sub>PDILIM</sub>	Propagation delay from ILIM to OUTA and OUTB outputs	Exclude leading edge blanking (UCC28251RGP)	15	25	36	ns
		Exclude leading edge blanking (UCC28251PW)	12.3	25.0	38.7	
T <sub>BLANK</sub>	Leading edge blanking		35	60	90	
	Current limit shutdown delay timing program current	Measured at HICC pin	55	75	95	$\mu$ A
	Hiccup timing program current	Measured at HICC pin	2.0	2.7	3.5	
V <sub>HICC_SD</sub>	Current limit shutdown delay timer threshold at HICC		0.55	0.60	0.65	V
V <sub>HICC_PU</sub>	HICC pull-up threshold		2.25	2.40	2.50	
V <sub>HICC_RST</sub>	Hiccup restart threshold		0.25	0.30	0.35	
V <sub>CS(max)</sub>	RAMP/CS clamp voltage	10-V ramp charging voltage source with 40-k $\Omega$ current limiting resistor	3.5	4.0	4.5	

**Electrical Characteristics<sup>(1)</sup> (continued)**

VDD = 12 V, 1- $\mu$ F capacitor from VDD and VREF to GND, T<sub>A</sub> = T<sub>J</sub> = -40°C to 125°C, RT = 75 k $\Omega$  connected to ground to set F<sub>SW</sub> = 100 kHz (unless otherwise noted).

PARAMETER		TEST CONDITIONS	MIN	TYP	MAX	UNIT
<b>OVP/OTP COMPARATOR</b>						
V <sub>OVP</sub>	Internal reference		0.66	0.70	0.74	V
I <sub>OVP</sub>	Internal current		6.0	8.5	11.0	$\mu$ A
<b>PRIMARY OUTPUTS</b>						
	Rise/fall time	C <sub>LOAD</sub> = 100 pF		8		ns
R <sub>SRC</sub>	Output source resistance	I <sub>OUT</sub> = 20 mA	12	20	35	$\Omega$
R <sub>SNK</sub>	Output sink resistance	I <sub>OUT</sub> = 20 mA	4	12	30	
<b>SYNCHRONOUS RECTIFIER OUTPUTS</b>						
	Rise/fall time	C <sub>LOAD</sub> = 100 pF		8		ns
R <sub>SRC</sub>	Output source resistance	I <sub>OUT</sub> = 20 mA, VDD = 12 V	12	20	35	$\Omega$
		I <sub>OUT</sub> = 20 mA, VDD = 5 V	15	25	45	
R <sub>SNK</sub>	Output sink resistance	I <sub>OUT</sub> = 20 mA, VDD = 12 V	4	12	30	
TD <sub>PS</sub>	Primary off to secondary on dead time	PS = VREF	-5.0	0	7.5	ns
		PS = 27 k $\Omega$	25	38	48	
		PS = 27 k $\Omega$ , 25 °C	32	38	43	
TD <sub>SP</sub>	Secondary off to primary on dead time	SP = VREF	-5.0	0	7.5	ns
		SP = 20 k $\Omega$	33	43	55	
		SP = 20 k $\Omega$ , 25 °C	39	43	48	

## 7.6 Typical Characteristics

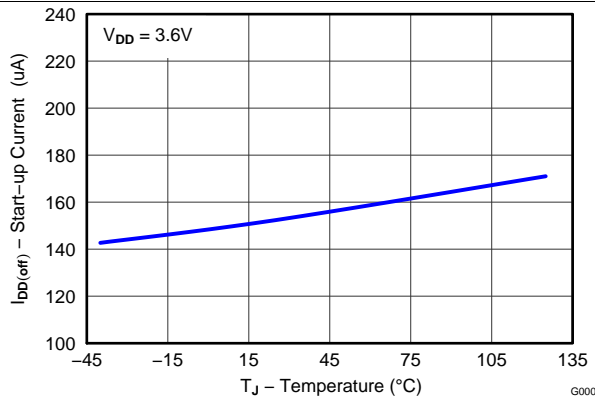

Figure 1. Start-Up Current vs Temperature

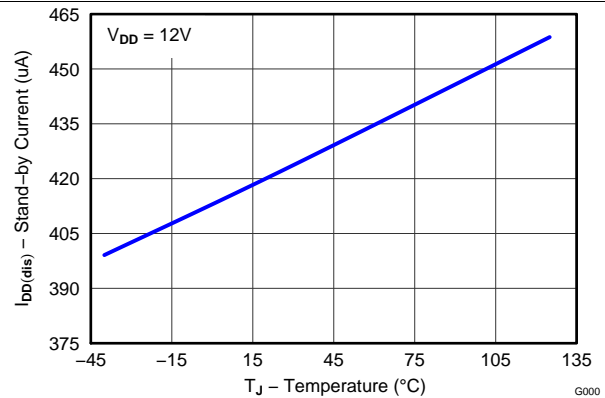

Figure 2. Stand-By Current vs Temperature

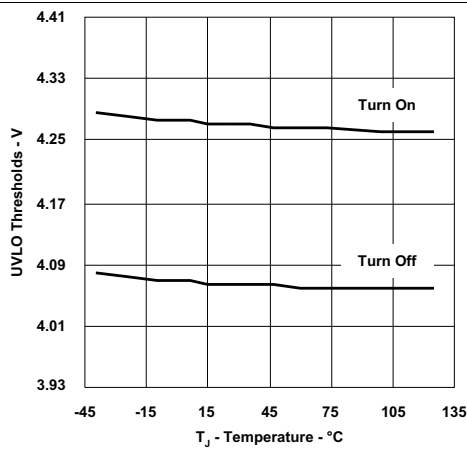

Figure 3. UVLO Thresholds vs Temperature

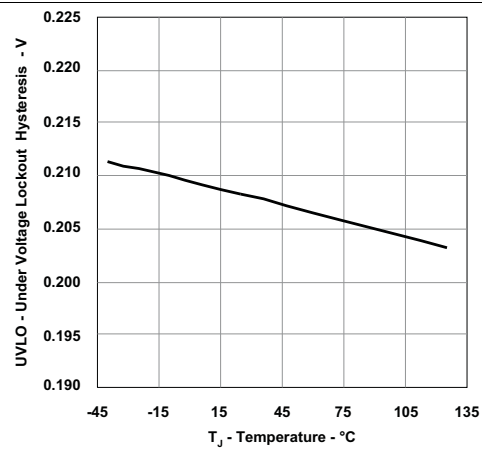

Figure 4. UVLO Voltage Lockout Hysteresis vs Temperature

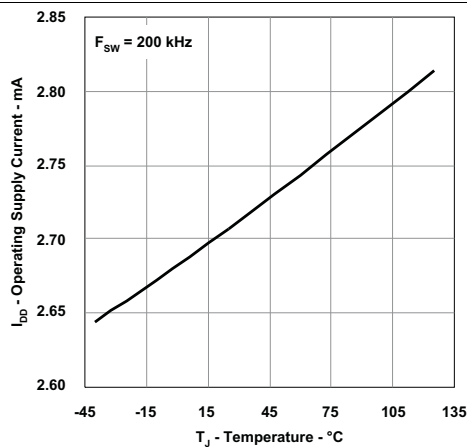

Figure 5. Operating Supply Current vs Temperature

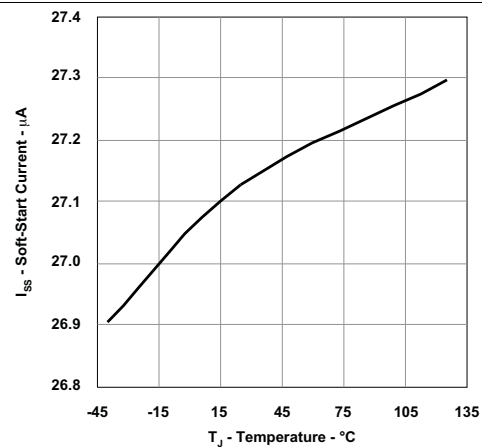
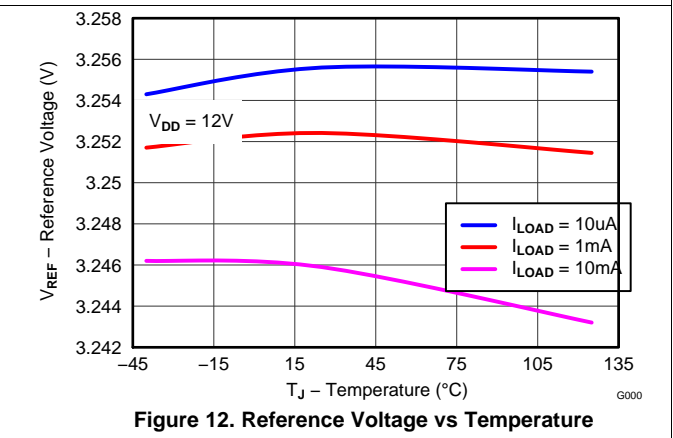
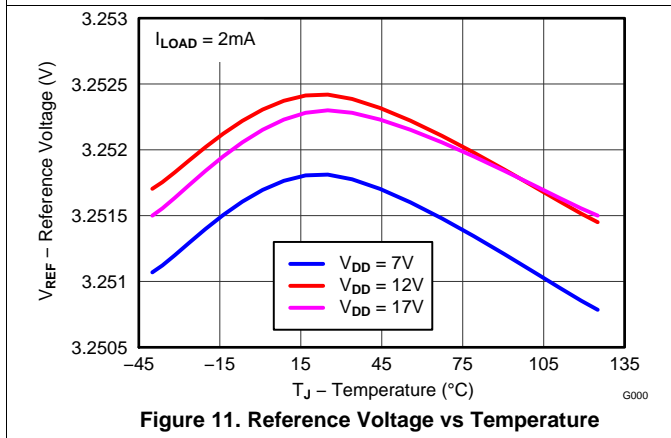
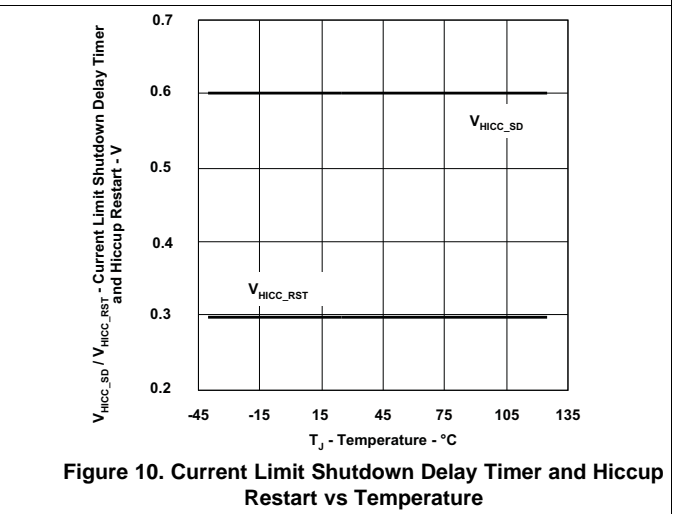
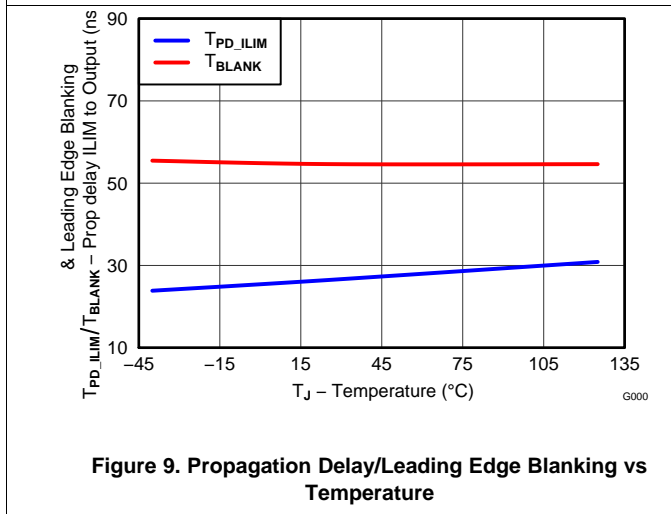
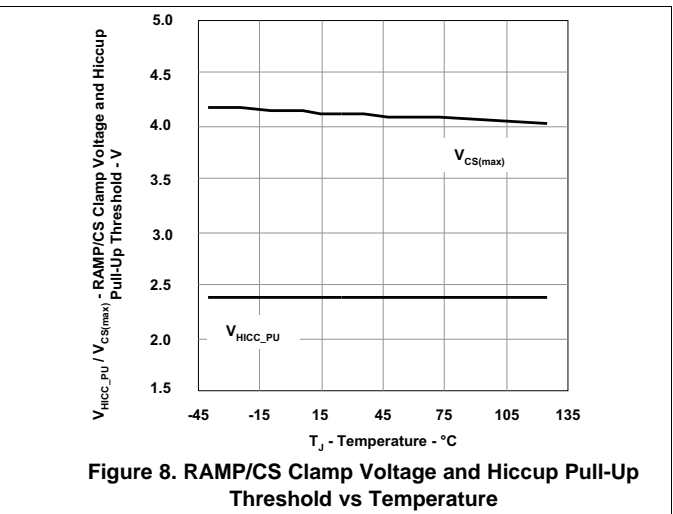
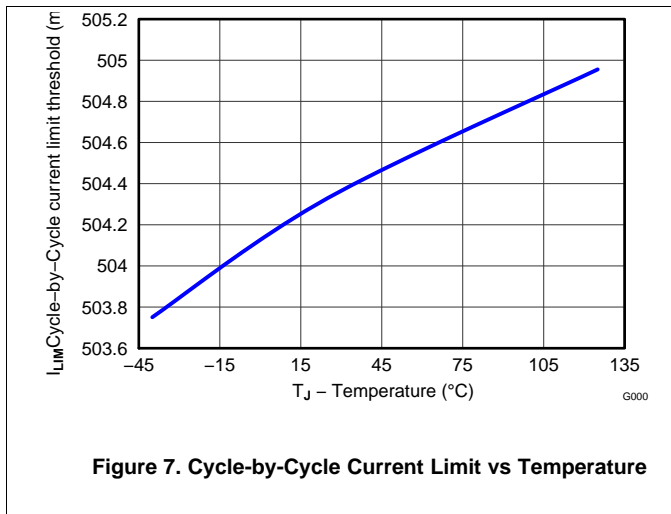
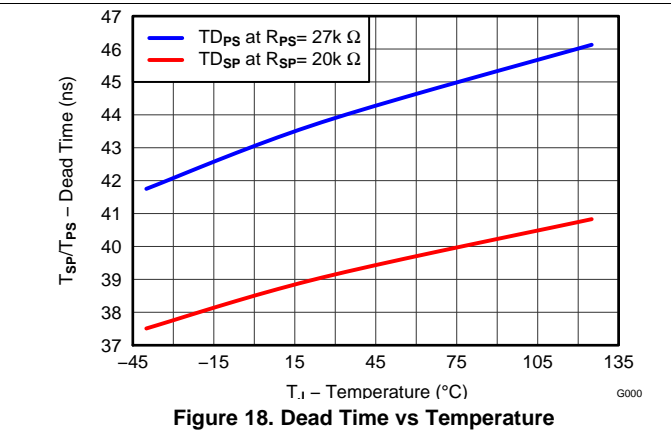
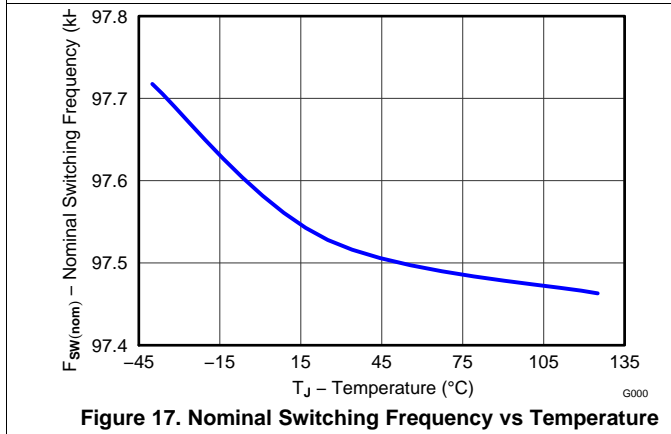
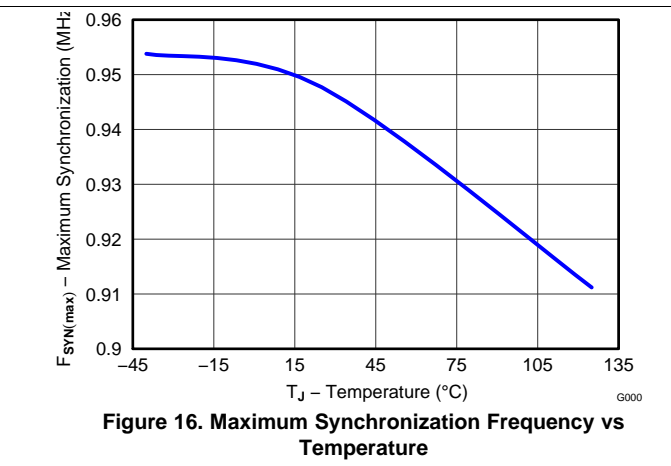
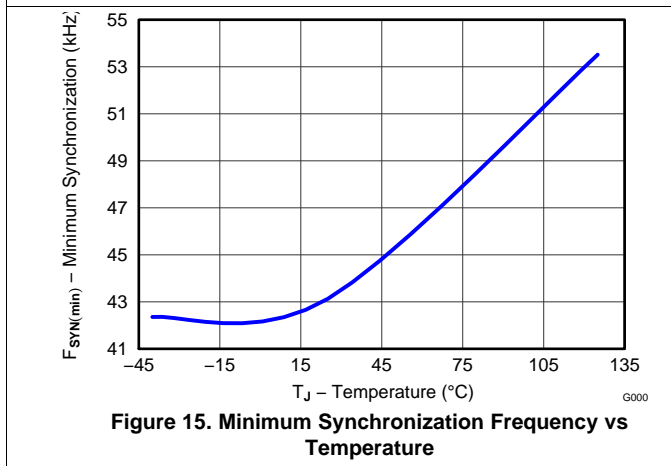
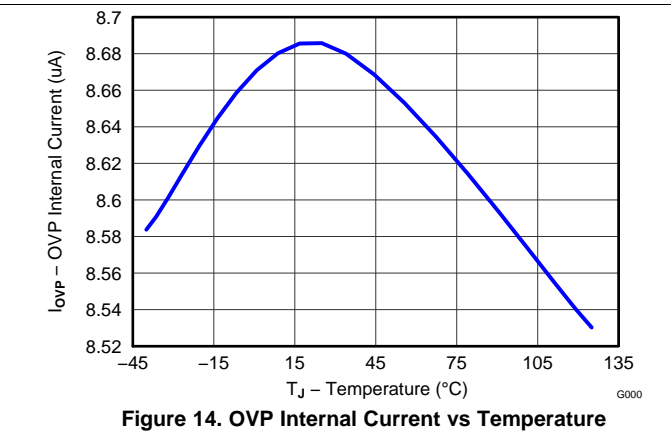
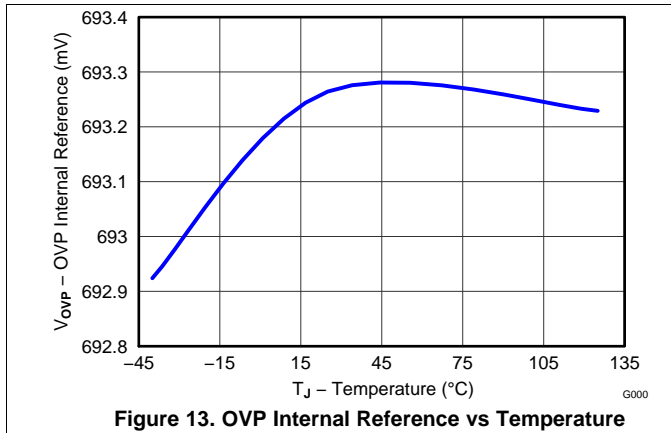

Figure 6. Soft-Start Current vs Temperature

Typical Characteristics (continued)



Typical Characteristics (continued)



**Typical Characteristics (continued)**

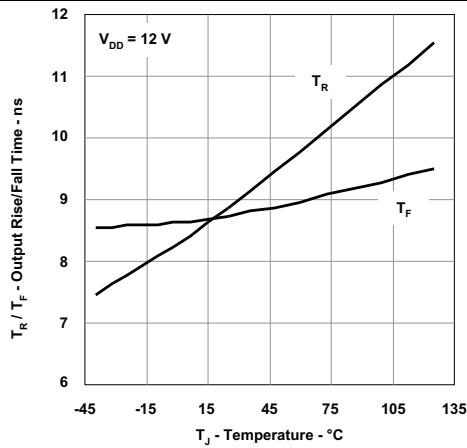

**Figure 19. Output Rise/Fall Time vs Temperature**

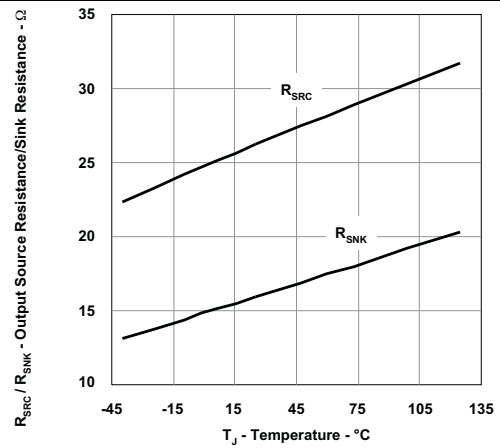

**Figure 20. Output Source Resistance/Sink Resistance vs Temperature**

## 8 Detailed Description

### 8.1 Overview

The UCC28251 is a functional variant of the UCC28250 PWM Controller. While the same basic functionality of the UCC28250 is largely maintained, the UCC28251 is designed to operate at a lower frequency (minimum of 27 kHz when programmed by RT pin) allowing operation in 400-V input DC-to-DC converters in off-line AC-to-DC power supplies, where frequency-dependent high-voltage switching losses are an important concern. Various other enhancements, (summarized in Table 1) made in UCC28251 that enhance the performance in both 400-V input and 48-V input full-bridge and half-bridge applications in server telecom power supplies.

#### 8.1.1 UCC28251 Enhancements Over the UCC28250

The UCC28251 is a functional variant of the UCC28250 PWM Controller. While the same basic functionality of the UCC28250 is largely maintained, the UCC28251 is designed to enhance performance in both offline, 400-V input DC-to-DC applications and 48-V input full-bridge or half-bridge applications. The overall improvements that are made in UCC28251 can be summarized in the table below:

**Table 1. UCC28251 Improvements**

NEW IN UCC28251	UCC28250	ENHANCEMENT
When synchronized to an external frequency source, the minimum switching frequency can be as low as 42 kHz. When programmed by R <sub>T</sub> resistor, the minimum switching frequency can be as low as 27 kHz.	UCC28250 does not allow support frequencies lower than 85 kHz.	UCC28251 enables better power efficiency in offline (400 V <sub>IN</sub> ) DC-to-DC converters.
PS and SP delay times are fully independent and maintain their programmed values under all conditions.	Whenever OUTA/B turn on time + ps delay is greater than ½ switching cycle time, the PS delay would be clamped (identical) to SP delay.	UCC28251 prevents shoot-through between primary and secondary side MOSFETs
EN shut down delay time shortened to ~1.5 μs (typical).	UCC28250 EN shutdown time was ~6 μs.	UCC28251 enables quicker shut down in offline DC-to-DC applications.
The synchronous rectifier outputs, SRA and SRB, are ensured to follow after the primary outputs and have a minimum 50% duty cycle during startup. SRA and SRB continue to be active and will only be disabled when UCC28251 is disabled.	The synchronous rectifier duty cycle will be equal to 0 when primary duty cycle is very narrow. This duty cycle loss can increased MOSFET V <sub>DS</sub> and cause poor reverse recovery.	UCC28251 reduces MOSFET stress and enables better reverse recovery.
UCC28251 startup is delayed by 20 μs typical after reaching V <sub>DD</sub> UVLO. This 20 μs delay provides enough time for SS pin to fully discharge.	No delay, immediate startup after UVLO is reached. After startup, if the applied V <sub>DD</sub> happens to drop below UVLO then rises back up above ULVO very quickly, the UCC28250's SS pin does not have enough time to discharge.	UCC28251 SS pin will fully discharge under V <sub>DD</sub> brownout conditions.
When OVP is detected, the internal current source now turn on for a minimum of 5 μs typical. This allows the capacitor connected to the OVP pin to be charged up sufficiently. (The internal current source has been changed to 8 μA).	In UCC28250, if the OVP comparator is triggered, the internal current source does not turn on for any minimum amount of time. In some cases this may result in the external OVP capacitor not being charged properly. This could result poor voltage hysteresis for OVP protection. (The internal current source is 11 μA).	UCC28251 allows over voltage protection to have enough voltage hysteresis.

## 8.2 Functional Block Diagram

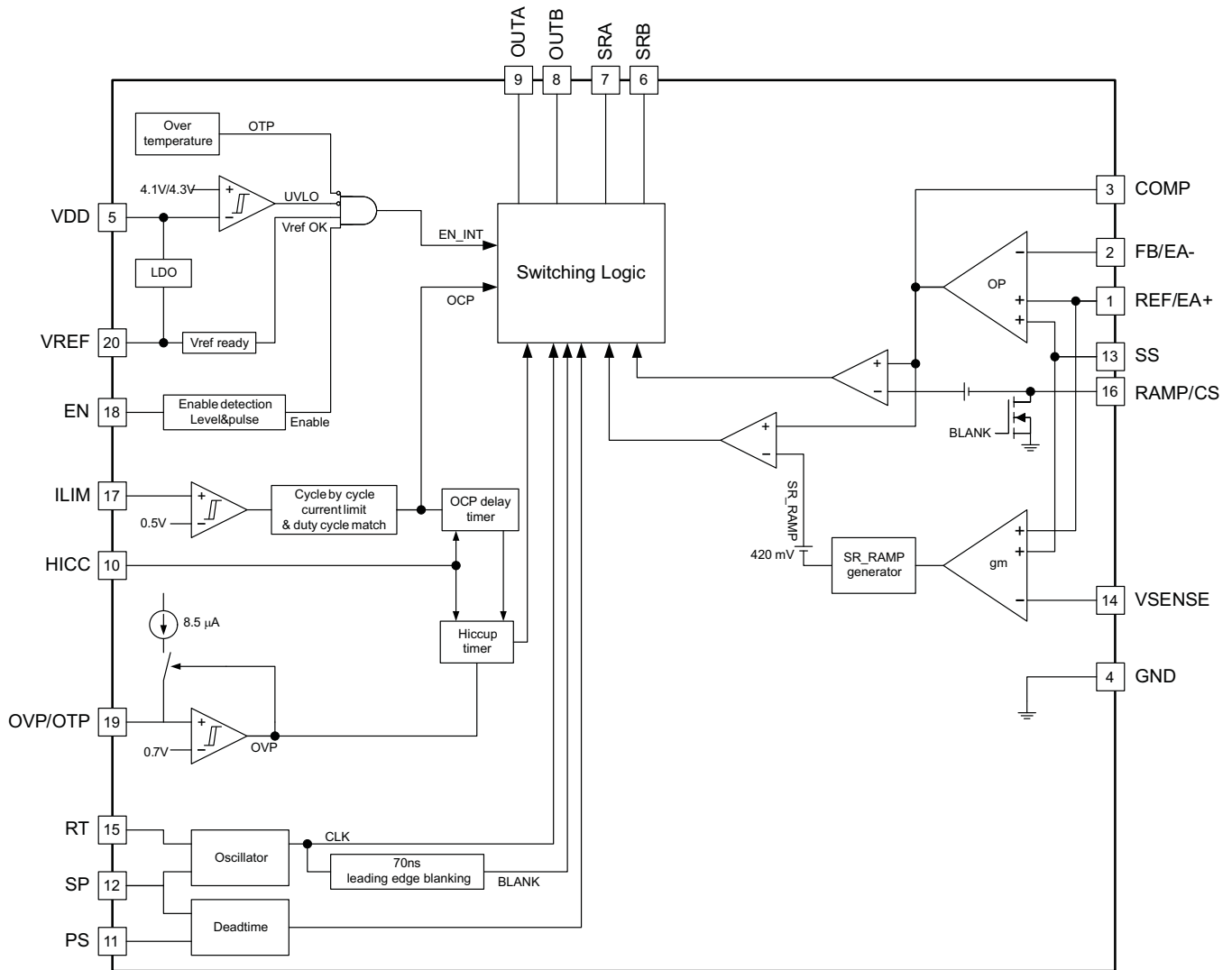

### NOTE

Pin numbers are used for RGP package. PW package has different pin numbers.

## 8.3 Feature Description

### 8.3.1 VDD (5/12)

The UCC28251 can be powered up by a wide supply range from 4.3 V (UVLO rising typical) to 20 V (absolute maximum), making it suitable for primary-side control or secondary-side control. When the voltage at the VDD pin is lower than 4.1 V (typical), the controller is in stand-by mode and consumes 150  $\mu$ A (typical) at 3.6 V VDD. In stand-by mode, VREF continues to be regulated to 3.3 V or follows VDD if VDD is lower than 3.3 V. Please refer to the VREF description for more detailed information. A minimum 1- $\mu$ F bypass capacitor is required from VDD to ground. Keep the bypass capacitor as close to the device as possible.

**Feature Description (continued)**

**8.3.2 VREF (Reference Generator) (20/7)**

The VREF pin is regulated at 3.3 V. An external ceramic capacitor must be placed as close as possible to the VREF and GND pins for noise filtering and to provide compensation to the regulator. The capacitance range must be limited between 0.47  $\mu$ F to 2.2  $\mu$ F for stability. This reference is used to power the controller’s internal circuits, and can also be used to bias an opto-coupler transistor, an external house-keeping microcontroller, or other peripheral circuits. This reference can also be used to generate the reference for an external error amplifier. This regulator output is internally current limited to 25 mA (typical).

**8.3.3 EN (Enable Pin) (18/5)**

The following conditions must be met before the controller allows start up:

1. VDD voltage has been sustained above the rising UVLO threshold 4.3 V (typical);
2. The 3.3-V reference voltage output at the VREF pin is 2.4 V (typical) for at least 20  $\mu$ s;
3. Junction temperature is below the thermal shutdown threshold 130°C (minimum);
4. The voltage at OVP is below 0.7 V (typical).

If all these conditions are met, the signal driving the EN pin is able to initiate the soft start process. Once the device is enabled, the 27- $\mu$ A internal charging current at the SS pin is turned on and begins to charge the soft-start capacitor. The EN pin can accept both level-enable and pulse-enable signals.

For level-enable, the voltage level on the EN pin needs to be continuously higher than 2.25 V to allow continuous operation. Once the EN pin falls below threshold, the device is disabled after 2  $\mu$ s (see [Figure 21](#)).

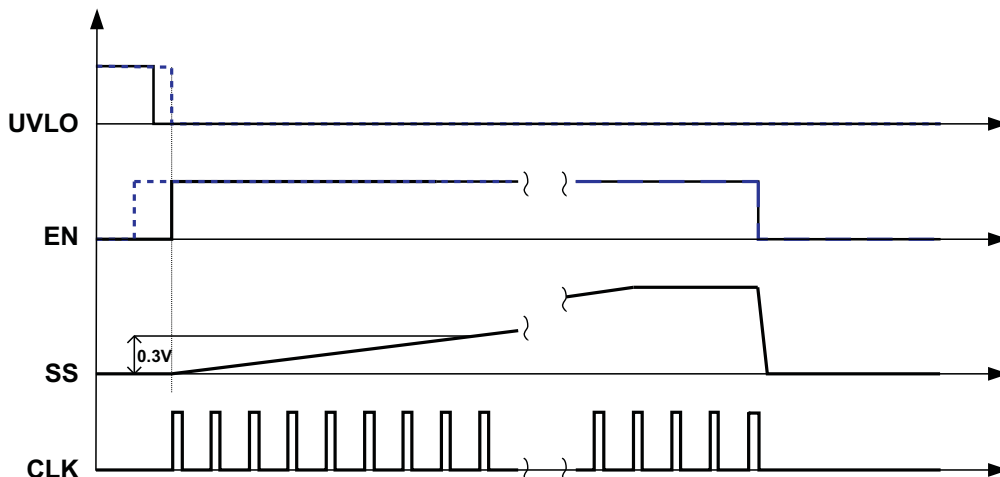

**Figure 21. Level Enable at EN Pin**

## Feature Description (continued)

A pulse signal may also be applied to the EN pin. Pulse-enable operation is shown on [Figure 22](#). If the EN falling edge happens before the SS voltage reaches 0.3 V, the enable signal at EN pin is considered as a pulse. In this case, the next rising edge at EN pin disables the controller. If the falling edge of the first pulse at EN pin happens after SS rises to 0.3 V, the UCC28251 interprets the pulse enable as a level enable, and an external solution as shown on [Figure 23](#) (a) can be used to reduce the pulse width. In this circuit, R2 is used to limit the current (especially the negative current) through the internal ESD cell. [Figure 23](#) (b) illustrates the waveforms based on this solution. To prevent false trigger by noises, the pulse at the EN pin must be at least 2.25 V (minimum) high and 3 μs wide to be considered valid.

Choose the R1, R2, and C values based on the following equations:

Choose R2 based on the current limit requirement of under 0.1 mA .

$$R_2 > 10k\Omega \quad (1)$$

Choose R1 arbitrarily but much smaller than R2 and choose C1 according to the time constant requirement to generate longer than 3-μs pulse.

$$C_1 = \frac{6\mu s}{R_1} \quad (2)$$

If enable function is not used, pull EN pin to VREF.

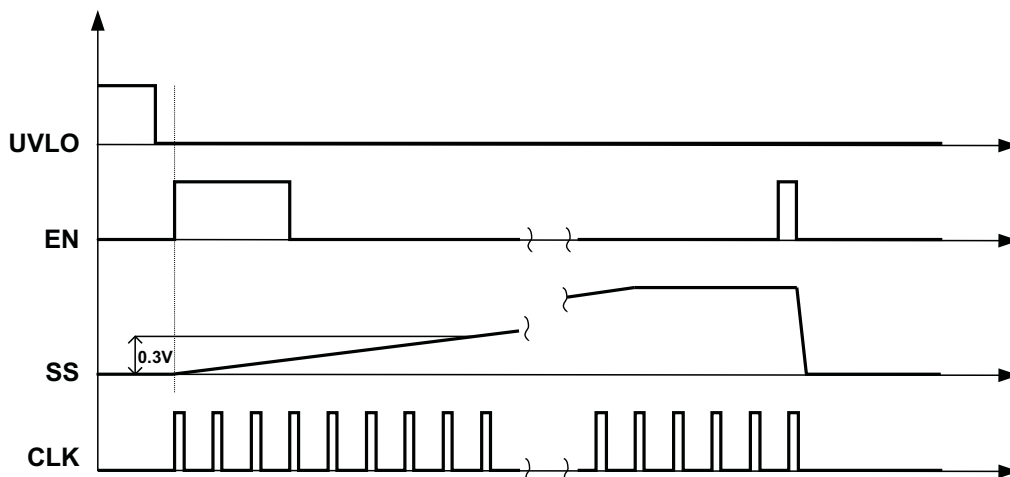

**Figure 22. Pulse Enable at EN Pin**

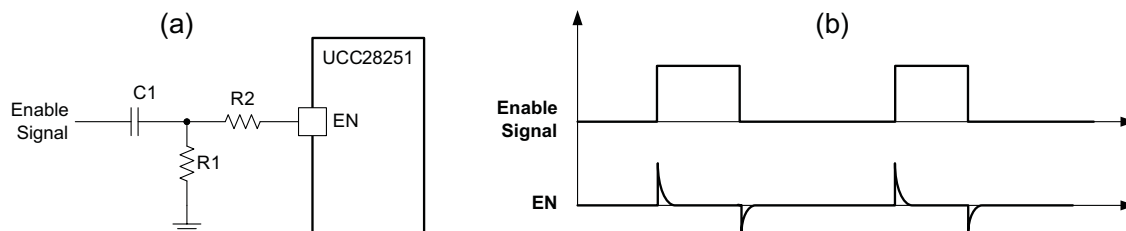

**Figure 23. An External Solution to Generate Enable Pulses for Pulse Enable**

## Feature Description (continued)

### 8.3.4 RT (Oscillator Frequency Set and Synchronization) (15/2)

The UCC28251 oscillator frequency is set by an external resistor connected between the RT pin and ground. The oscillator frequency can be set to any value between 50 kHz to 1.4 MHz, which is equivalent to an 25-kHz to 700-kHz switching frequency. Switching frequency selection is a trade-off between efficiency and component size. Based on the selected switching frequency, the programming resistor value can be calculated as:

$$R_T = \frac{1}{2 \times f_{SW} - t_{D(SP)}} \times 66.4 \text{ pF} \quad (3)$$

In this equation,  $f_{SW}$  is the switching frequency and  $T_{D(SP)}$  is the dead time between synchronous rectifier turn-off to primary switch turn-on.  $T_{D(SP)}$  is set by an external resistor between the SP pin and ground (refer to the SP pin description).

Each output (OUTA, OUTB, SRA, SRB) switches at half the oscillator frequency ( $f_{SW} = \frac{1}{2} \times f_{OSC}$ ). [Figure 24](#) shows the relationship between RT and  $f_{OSC}$  at certain  $T_{D(SP)}$  and can be used to program oscillator frequency accordingly.

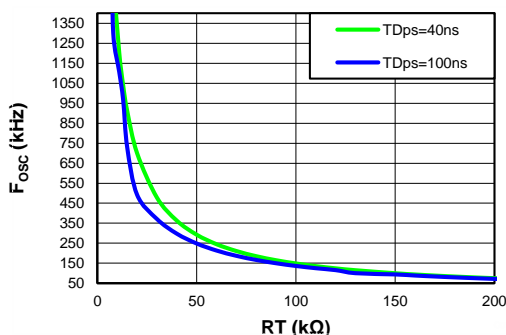
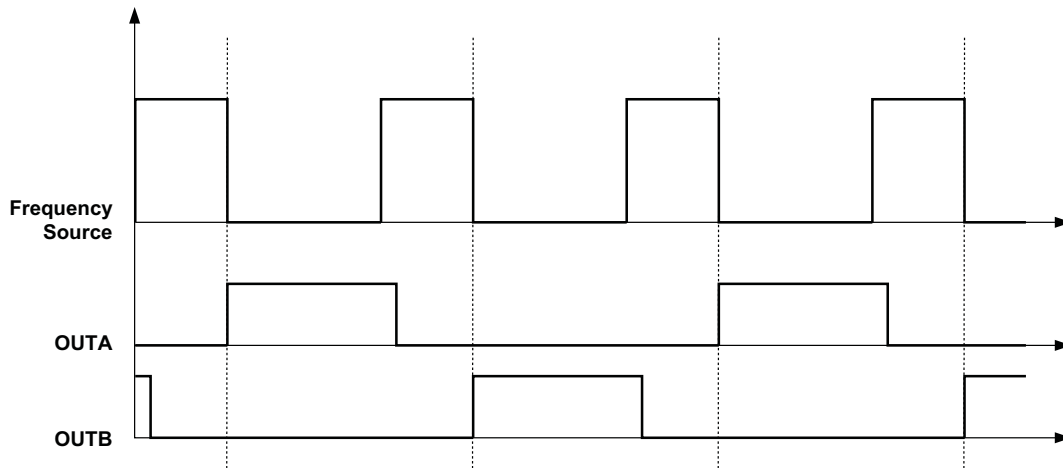

**Figure 24. Oscillator Frequency  $F_{OSC}$  vs External Resistance of  $R_t$  at  $T_{D(ps)} = 40 \text{ ns}$  and  $100 \text{ ns}$**

The UCC28251 can be synchronized to an external clock by applying an external clock source to the RT pin. Synchronization helps with parallel operation and/or preventing beat frequency noise. The UCC28251 synchronizes its internal oscillator to an external frequency source ranging from 84 kHz to 1.89 MHz, which is equivalent to an 42-kHz to 0.945-MHz switching frequency. The internal oscillator frequency is clamped to 84 kHz during synchronization if the external source frequency drops below 84 kHz.

The UCC28251 aligns the turn-on of primary outputs OUTA and OUTB to the falling edge of the synchronizing signal, as shown in [Figure 25](#). If the frequency source is from the gate outputs of another half bridge controller, interleaving can be achieved. The interleaving angle is determined by the frequency source's duty cycle. When a 50% duty cycle is applied, optimal interleaving is achieved, and EMI filters can be minimized.

**Feature Description (continued)**



**Figure 25. Timing Diagram for Synchronization**

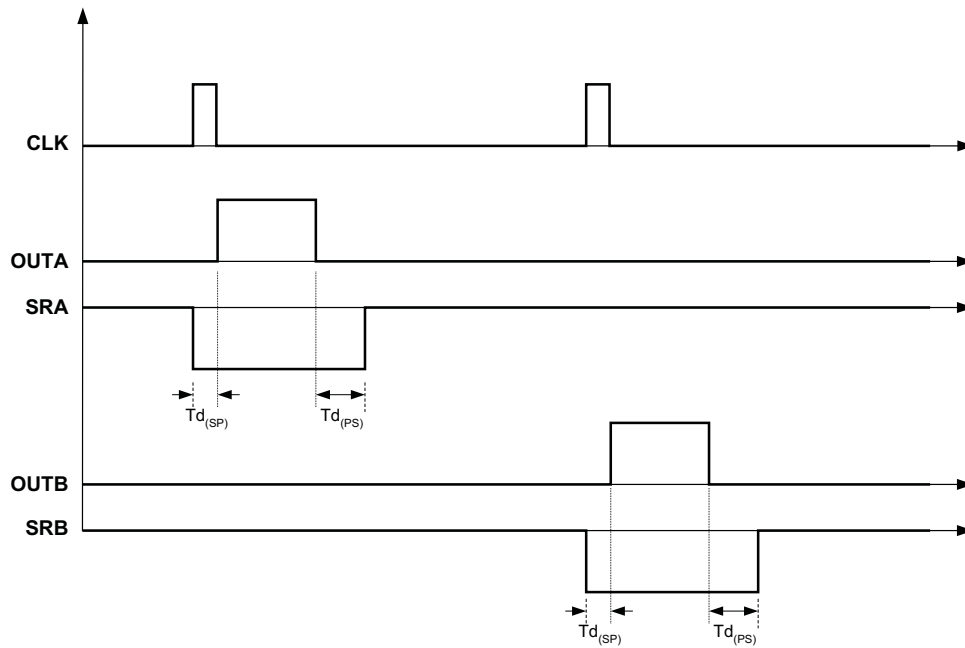

**Figure 26. UCC28251 Outputs Timing Waveforms**

**Feature Description (continued)**

**8.3.5 SP (Synchronous Rectifier Turn-Off to Primary Output Turn-On Dead Time Programming) (13/19)**

The dead time  $T_{D(SP)}$  between synchronous rectifier turn-off to primary output turn-on is programmed by an external resistor,  $R_{SP}$ , connected between the SP pin and ground. The value of  $R_{SP}$  can be determined by [Figure 27](#). Zero dead time can be achieved by tying the SP pin to VREF. The falling edge of synchronous rectifier SRA/SRB is aligned with the rising edge of the primary output OUTA/OUTB.

**NOTE**

The minimum value for  $R_{PS}$  and  $R_{SP}$  is 5 kΩ and the maximum value is 250 kΩ.

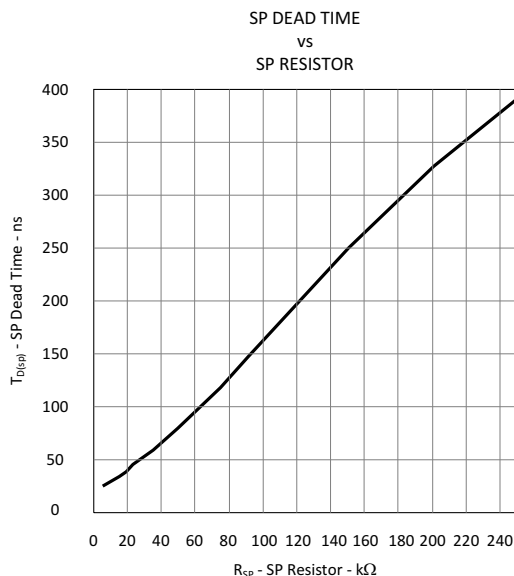

**Figure 27. Dead Time  $T_{D(SP)}$  vs. External Resistor  $R_{SP}$  at SP Pin**

**8.3.6 PS (Primary Output Turn-Off to Synchronous Rectifier Turn-On Dead Time Programming) (11/18)**

The dead time  $T_{D(PS)}$  between primary output turn-off to synchronous rectifier turn-on is set by external resistor,  $R_{PS}$ , connected between PS pin and ground. The value of  $R_{PS}$  is defined by [Figure 28](#). Zero dead time can be achieved by tying the SP pin to VREF.

**NOTE**

The minimum value for  $R_{PS}$  and  $R_{SP}$  is 5 kΩ and the maximum value is 250 kΩ.

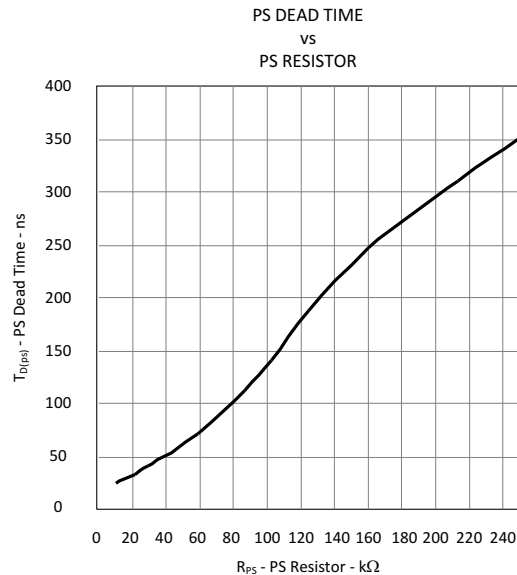
**Feature Description (continued)**

**Figure 28. Dead Time T<sub>D(PS)</sub> vs. External Resistor R<sub>PS</sub> at PS Pin**

**8.3.7 RAMP/CS (PWM Ramp Input or Current Sense Input) (16/3)**

The UCC28251 can be controlled using either voltage mode or current mode. RAMP/CS is a multi-function pin used either to generate the ramp signal for voltage mode control or to sense current for current mode control. The following sections describe the RAMP/CS functionality for voltage mode and current mode control.

**8.3.7.1 RAMP: Voltage Mode Control With Feed-Forward Operation**

For voltage mode control, a resistor R<sub>CS</sub> and a capacitor C<sub>CS</sub> must be connected to the RAMP/CS pin as shown in Figure 29. The internal pull-down switch has approximately 40-Ω on-resistance. The RAMP/CS pin is clamped internally to not exceed 4 V for internal device protection. The C<sub>CS</sub> value must be small enough to discharge the RAMP/CS pin from its peak voltage to ground within the pulse width of the BLANK signal (T<sub>D(SP)</sub> + 70 ns). The following formula derives a C<sub>CS</sub> value.

$$C_{CS} < \left( \frac{4V/2}{40\Omega} \right) \times \frac{T_{D(SP)} + 70ns}{4V} \quad (4)$$

A C<sub>CS</sub> value less than 650 pF works for most applications. In order to minimize the impacts of parasitic capacitance caused by the PCB layout and routing, a minimum of 100 pF is recommended for C<sub>CS</sub>. Once C<sub>CS</sub> is determined, R<sub>CS</sub> can be calculated according to the desired ramp peak amplitude.

$$R_{CS} = \frac{1}{2 \times \ln \left( \frac{V_{CHARGE}}{V_{CHARGE} - V_{PK}} \right) \times C_{CS} \times f_{SW}} \quad (5)$$

In this equation, the V<sub>CHARGE</sub> is the voltage used to generate the ramp, V<sub>PK</sub> is the desired ramp amplitude and the f<sub>SW</sub> is the switching frequency.

Feature Description (continued)

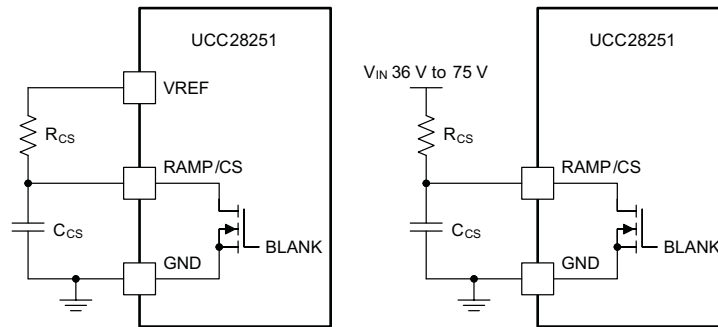

Figure 29. Fixed Ramp Generation/Ramp Generation With Input Voltage Feedforward

Voltage feed-forward can be achieved by driving  $R_{CS}$  from line input  $V_{IN}$ . The peak of RAMP/CS is proportional to  $V_{IN}$  and output will have much faster line transient response. When the UCC28251 is used for the primary-side control, RAMP parameters are critical for the optimal pre-biased start up performance. Refer to the 'Voltage Mode Control and Input Voltage Feed-Forward' section of the Functional Description section for a detailed design procedure of choosing  $R_{CS}$ .

If the line input cannot be easily accessed due to limited board area or other limitation, a RAMP signal with fixed peak voltage can be implemented by simply driving  $R_{CS}$  from 3.3 V VREF (Figure 29).

8.3.7.2 CS: Current Mode Control

For current mode control, the RAMP/CS pin is driven by a signal representative of the transformer primary-side current. The current signal has to have compatible input range of the COMP pin. As shown in Figure 30, the COMP pin voltage is used as the reference for peak current. The primary-side signals OUTA and OUTB are turned on by the internal clock signal and turned off when sensed peak current reaches the COMP pin voltage. Choose the current sense transformer turns ratio (1:n) and the burden resistor value ( $R_B$ ) based on the peak current at maximum load  $I_{MAX}$ . Refer to the Functional Description section for more details on the current mode control.

$$R_B = \frac{3V}{I_{MAX} / n} \tag{6}$$

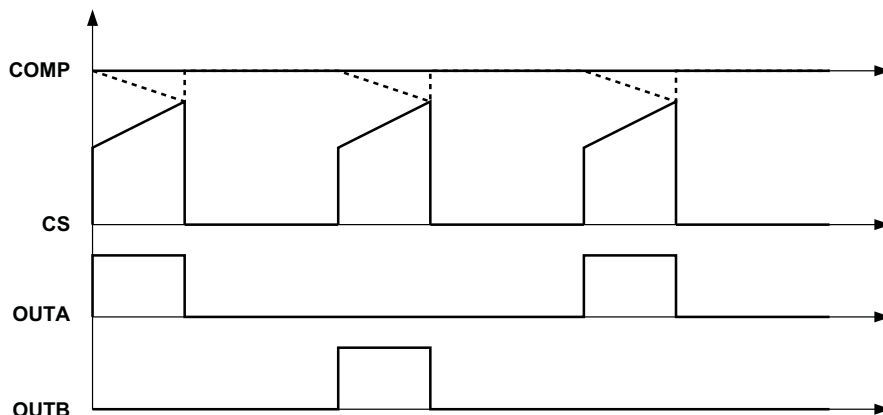

Figure 30. Peak Current Mode Control and PWM Generation

8.3.8 REF/EA+ (1/8)

REF/EA+ is the non-inverting input of the UCC28251's internal error amplifier.

## Feature Description (continued)

When the UCC28251 is configured for secondary-side control, the internal error amplifier is used as the control loop error amplifier. Connect REF/EA+ directly to the VREF pin to provide the reference voltage for the feedback loop.

When the UCC28251 is configured for primary-side control, the error amplifier is connected as a voltage follower. Connect REF/EA+ to the opto-coupler output.

The voltage range on REF/EA+ pin is 0 V to 3.7 V.

### 8.3.9 FB/EA– (2/9)

FB/EA- is the inverting input of the UCC28251's internal error amplifier.

When the UCC28251 is configured for secondary-side control, connect the output voltage sensing divider to this pin. The voltage divider can be selected according to the voltage on REF/EA+ pin. Referring to [Figure 32](#), pick the lower resistor  $R_{O1}$  value arbitrarily, and choose the upper resistor  $R_{O2}$  value as:

$$R_{O2} = \left( \frac{V_o}{V_{REF/EA+}} - 1 \right) \times R_{O1} \quad (7)$$

Because the control loop gain is affected by voltage divider resistor values, choose an appropriate  $R_{O1}$  value so that the voltage loop DC gain is larger than 40 dB to prevent interference between the primary-side control loop and the SR control loop during start up.

When the UCC28251 is sitting on the primary side, the error amplifier is connected as a voltage follower. Connect FB/EA- directly with COMP pin.

The maximum voltage allowed on FB/EA- pin is 3.7 V.

### 8.3.10 COMP (3/10)

The COMP pin is the internal error amplifier's output and also the input signal for PWM comparator. The maximum input common voltage of the PWM comparator is 2.8 V. It is suggested to program the peak value of RAMP to be lower than 2.3 V. Otherwise, the voltage of COMP pin should be clamp to be lower than 2.8 V by external circuit in order to make the internal PWM comparator work properly. An external circuit detailed as below is recommended for voltage clamp function. Both the primary-side switches' duty cycle and secondary-side SRs' duty cycle is controlled by the COMP pin voltage. At steady state, a higher COMP pin voltage results in a larger duty cycle for the primary-side switches and a smaller duty cycle on the SRs.

When the UCC28251 controller is set up for secondary-side control, connect the compensation network from the FB/EA- pin to the COMP pin.

For primary-side control, the error amplifier is connected as a voltage follower. Directly connect the COMP pin to the FB/EA- pin.

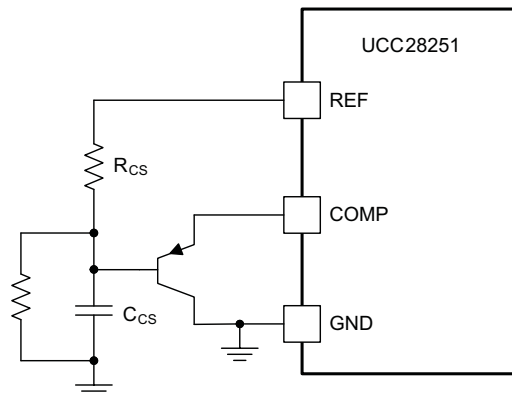

**Figure 31. Comp Clamp Circuit**

## Feature Description (continued)

### 8.3.11 VSENSE (14/1)

The VSENSE pin is used to directly sense the output voltage and to feed it into a transconductance error amplifier. The measured voltage allows the UCC28251 to achieve optimal pre-biased start up performance.

When configured as a secondary-side controller, the output voltage is sensed and fed into the FB/EA- pin. The UCC28251 uses a conventional error amplifier approach to allow type III compensation. Therefore, the FB/EA- pin voltage always follows the REF/EA+ voltage. The FB/EA- pin does not reflect the true output voltage and therefore this dedicated VSENSE pin is required. The voltage divider connected to VSENSE is discussed in the Pre-Biased Start-Up Section.

When UCC28251 is set up as primary-side control, connect VSENSE pin to VREF.

### 8.3.12 SS (Soft Start Programming Pin) (13/20)

The soft-start circuit gradually increases the converter's output voltage until steady state operation is reached. This reduces start-up stresses and current surge.

When the UCC28251 reaches its valid operating threshold, the SS pin capacitor is charged with a 27- $\mu$ A current source. The UCC28251's internal error amplifier non-inverting terminal follows the SS pin voltage on REF/EA+ pin voltage depending on which one is lower. Hence, during soft start, the SS pin voltage is lower than REF/EA+. The internal error amplifier then uses the SS pin as its reference voltage, until the SS pin voltage rises above the REF/EA+ level. Once the SS pin voltage is above REF/EA+ voltage, soft-start time is considered finished.

The soft-start implementation scheme and timing is different, depending on the location of the UCC28251 with respect to the isolation barrier.

For secondary-side control, the internal error amplifier is used to achieve the voltage regulation. The REF/EA+ is connected to an external reference voltage, FB/EA- is connected to the voltage sensing divider, and the error amplifier's output pin (COMP) is connected through a compensation filter back to the FB/EA- pin (Figure 32). In this case, the primary output's start-up is a closed loop soft start (soft-start input reference of error amplifier). The output soft-start time is determined by the external capacitor connected at SS pin based on the internal 27- $\mu$ A charging current and the voltage set at REF/EA+ pin.

Based on the soft-start time  $T_{SS}$ , choose soft start capacitor  $C_{SS}$  value as:

$$C_{SS} = \frac{27 \mu\text{A} \times T_{SS}}{V_{REF/EA+}} \quad (8)$$

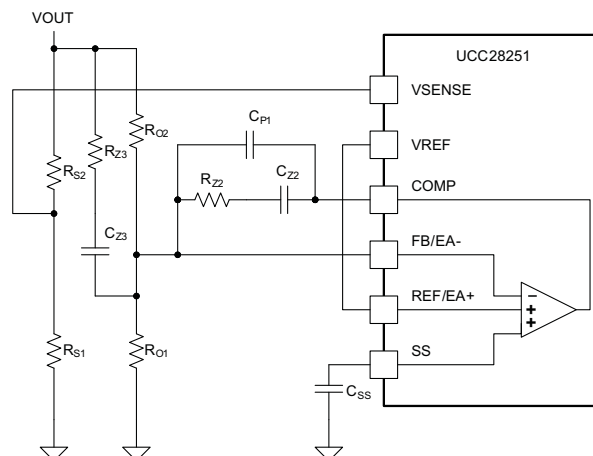

Figure 32. Error Amplifier EAMP Connections for Secondary-Side Control

## Feature Description (continued)

For primary-side control, the internal error amplifier is connected as a buffer stage. In other words, the COMP pin is shorted to the FB/EA- pin, and the output of an external error amplifier is connected to the REF/EA+ pin through an optical coupler (Figure 33). In this case, the output start-up is an open loop soft start because the COMP follows the soft-start voltage instead of the voltage loop output. The soft-start time is still determined by external capacitor  $C_{SS}$  and the 27- $\mu\text{A}$  internal charge current. The voltage depends on the value of final COMP voltage which corresponds to the regulated primary output duty cycle. According to the desired soft start time and COMP pin voltage level at steady state, the SS pin capacitor can be calculated as:

$$C_{SS} = \frac{27 \mu\text{A} \times T_{SS}}{V_{\text{COMP\_final}}} \quad (9)$$

After soft start, the voltage at SS pin is eventually clamped at around 4 V. Under fault conditions (UVLO, internal thermal shut down, OVP/OTP, hiccup mode), or when externally disabled, SS pin is pulled down to ground quickly by an internal switch with 2 k $\Omega$  on resistance to prepare for re-start. Pulling SS pin to ground externally shuts down the controller as well.

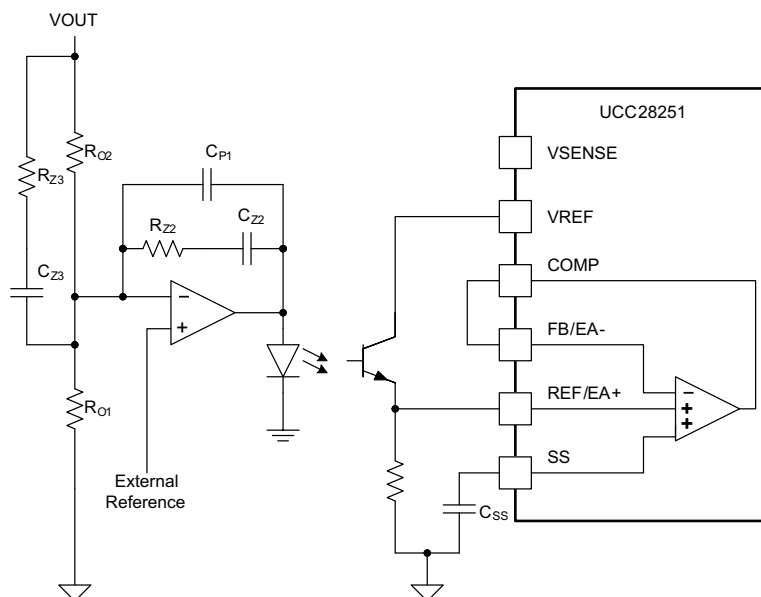

**Figure 33. Error Amplifier EAMP Connections for Primary-Side Control**

### 8.3.13 ILIM (Current Limit for Cycle-by-Cycle Over-Current Protection) (17/4)

Cycle-by-cycle current limit is accomplished using the ILIM pin for current mode control or for voltage mode control. The input to the ILIM pin represents the primary current information. If the voltage sensed at ILIM pin exceeds 0.5 V, the current sense comparator terminates the pulse of output OUTA or OUTB. If the high current condition persists, the controller operates in a cycle-by-cycle current limit mode with duty cycle determined by the current sense comparator instead of the PWM comparator. ILIM pin is pulled down by an internal switch when OUTA or OUTB goes low. This internal switch remains on for an additional 70 ns after OUTA or OUTB goes high to blank leading edge transient noise in the current sensing loop. This reduces the filtering requirements at the ILIM pin and improves the current sense response time.

Feature Description (continued)

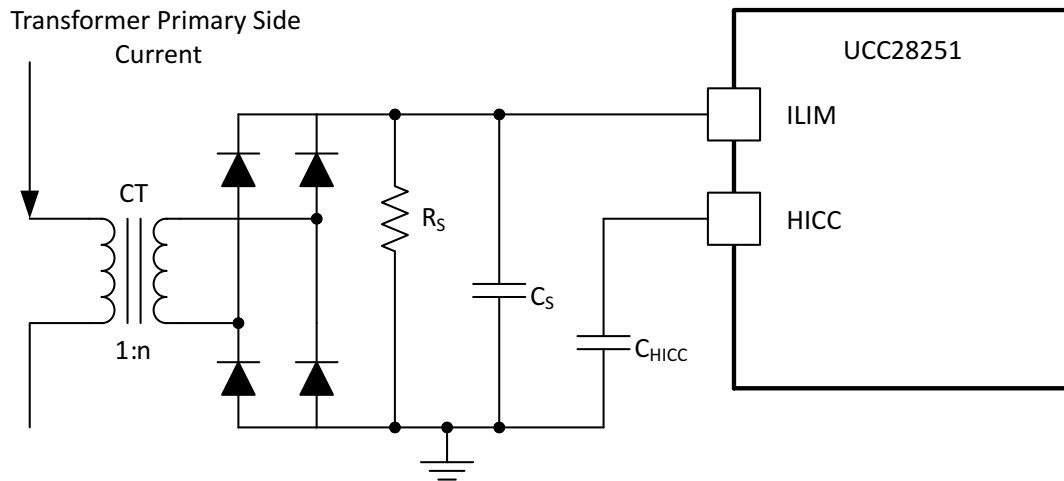

Figure 34. Current Limit Circuit

Once the over current protection level  $I_{PK}$  is selected, the current transformer turns ratio and the burden resistor value can be decided as:

$$R_s = \frac{0.5V \times n}{I_{PK}} \tag{10}$$

In this equation, current transformer turns ratio is 1:n and  $R_s$  is the burden resistor value.

Some filtering capacitance is required to reduce the sensing noise. Choose the RC constant at about 100 ns, and calculate the capacitor value as:

$$C_s = \frac{100ns}{R_s} \tag{11}$$

The cycle-by-cycle current limit operation time before all four outputs shut down can be programmed by external capacitor  $C_{HICC}$  at HICC pin. (See HICC pin description)

8.3.14 HICC (10/17)

The cycle-by-cycle current limit operation time before all four outputs shut down can be programmed by an external capacitor  $C_{HICC}$  from HICC pin to ground, as shown in Figure 34. Once all four outputs are shutdown, controller goes into hiccup cycle which is about 100 times the cycle-by-cycle current limit shut-down delay time. A 1-mA internal current source charges HICC pin up to 2.4 V, then the HICC pin is discharged by a 2.7- $\mu$ A internal current source to generate long hiccup restart time until HICC reaches 0.3 V. Based on the system requirement, once the cycle-by-cycle current limit delay time  $T_{OC(delay)}$  is selected, the HICC pin capacitor  $C_{HICC}$  can be selected based on the equation

$$C_{HICC} = \frac{T_{OC(delay)} \times 75\mu A}{0.6V} \tag{12}$$

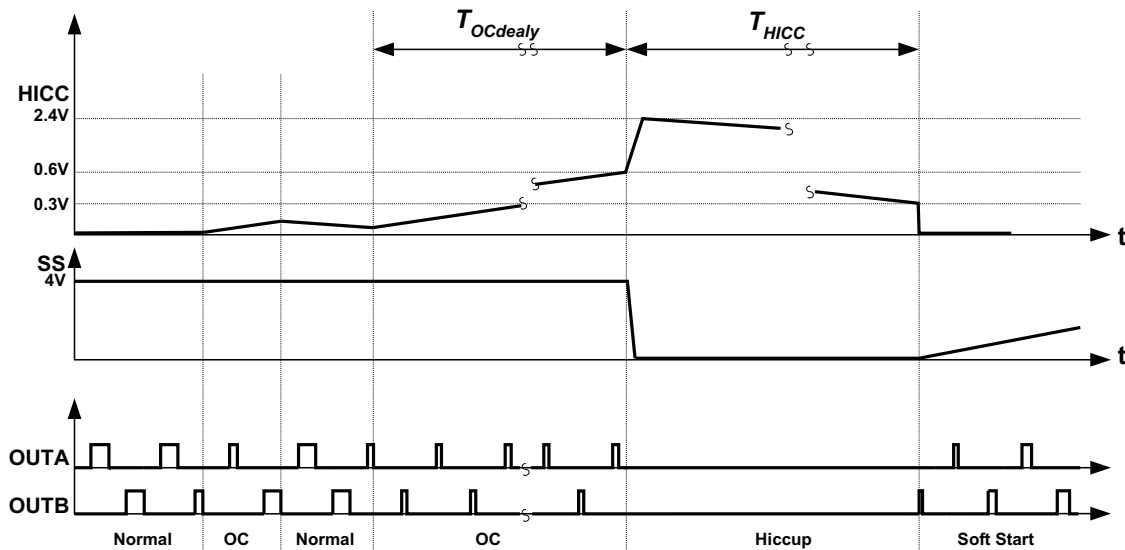
**Feature Description (continued)**

**Figure 35. Cycle-by-Cycle Current Limit Delay Timer and Hiccup Restart Timer**

As shown in [Figure 35](#), cycle-by-cycle current limiting shut-down delay time is:

$$T_{OC(\text{delay})} = C_{HICC} \times \frac{0.6\text{ V}}{75\ \mu\text{A}} \quad (13)$$

And hiccup-restart-time  $T_{HICC}$  is equal to:

$$T_{HICC} = C_{HICC} \times \frac{2.4\text{ V} - 0.3\text{ V}}{2.7\ \mu\text{A}} \quad (14)$$

As soon as the outputs are shut-down, the SS pin is pulled to ground internally until the hiccup restart timer is reset after time duration  $T_{HICC}$ .

**8.3.15 OVP/OTP (19/6)**

The OVP/OTP pin provides multiple fault protection functions. If the voltage on the OVP/OTP pin exceeds 0.7 V, a fault shutdown occurs. All outputs stop switching and stay off (low) during the shutdown, and the SS pin is pulled to ground internally. Once the fault condition is cleared (i.e. OVP/OTP voltage drops below 0.7 V), the UCC28251 enters hiccup mode. A soft-start cycle begins after the hiccup cycle is finished. An internal 8.5- $\mu\text{A}$  switched current source is used to create hysteresis.

If the external resistor divider runs from line voltage  $V_{IN}$ , a line over voltage protection is implemented.

If the external resistor divider runs from the output voltage, output over voltage fault protection is achieved. [Figure 36](#) shows the over-voltage protection external configuration at the OVP/OTP pin.

According to the protection threshold  $V_R$  and recovery threshold  $V_F$ , choose an arbitrary  $R_2$  value. To ensure a realistic solution,  $R_2$  needs to meet the following:

$$R_2 < \frac{0.7\text{ V} \times (V_R - V_F)}{8.5\ \mu\text{A} \times (V_R - 0.7\text{ V})} \quad (15)$$

The other two resistors,  $R_1$  and  $R_3$  can be calculated.

$$R_1 = \frac{V_R - 0.7\text{ V}}{0.7\text{ V}} \times R_2 \quad (16)$$

**Feature Description (continued)**

$$R_3 < \frac{0.7V \times (V_R - V_F) - 11\mu A \times R_2 \times (V_R - 0.7V)}{8.5\mu A \times V_R} \tag{17}$$

If the external resistor divider runs from 3.3-V VREF, and replaces R<sub>2</sub> with a positive temperature coefficient (PTC) thermistor, an over temperature fault protection with programmable hysteresis is accomplished (Figure 37). Choose an arbitrary PTC value, which has a resistance as R<sub>PTC1</sub> at protection temperature and resistance as R<sub>PTC2</sub> at recovery temperature. Because of its positive temperature coefficient, R<sub>PTC1</sub> is larger than R<sub>PTC2</sub>. To ensure an available solution, R<sub>PTC1</sub> and R<sub>PTC2</sub> need to meet the criteria.

$$0.7V \times (R_{PTC1} - R_{PTC2}) - 8.5\mu A \times R_{PTC1} \times R_{PTC2} \geq 0 \tag{18}$$

And resistors R<sub>1</sub> and R<sub>3</sub> can be calculated as:

$$R_1 = 3.7 \times R_{PTC1} \tag{19}$$

$$R_3 < \frac{2.6V \times [0.7V \times (R_{PTC1} - R_{PTC2}) - 8.5\mu A \times R_{PTC1} \times R_{PTC2}]}{8.5\mu A \times (2.6 \times R_{PTC1} + 0.7V \times R_{PTC2})} \tag{20}$$

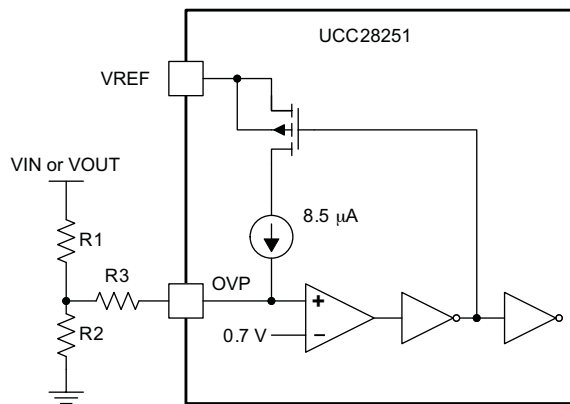

**Figure 36. Overvoltage Protection**

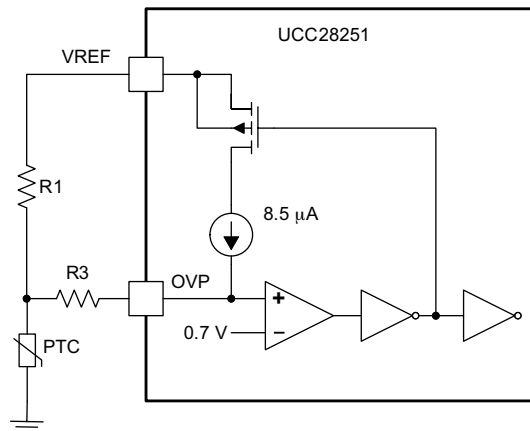

**Figure 37. Overtemperature Protection**

Figure 38 shows an external configuration using the OVP/OTP pin to achieve both overvoltage and overtemperature protection. Follow the same design procedure for the OVP setting to choose R<sub>1</sub>, R<sub>2</sub>, and R<sub>3</sub>. Choose an NTC value at protection temperature much smaller than R<sub>1</sub> and with the resistance at protection temperature as R<sub>NTC1</sub>, and recover temperature as R<sub>NTC2</sub>. The R<sub>4</sub> value can be calculated as:

**Feature Description (continued)**

$$R_4 = \frac{0.7\text{ V}}{3.3\text{ V} - 0.7\text{ V}} \times R_{\text{NTC}1} \quad (21)$$

Because of the interaction between the two voltage dividers, over temperature protection thresholds move slightly with the different input voltages.

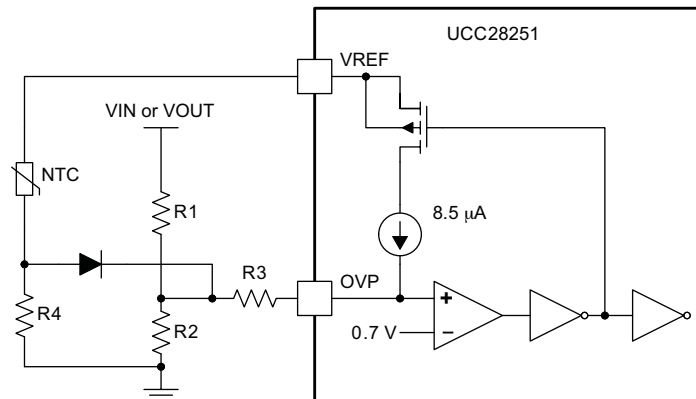

**Figure 38. Overvoltage and Overtemperature Protection With Single OVP Pin**

**8.3.16 OUTA (9/16) and OUTB (8/15)**

OUTA and OUTB are the primary-side switch control signals. With the 0.2-A peak current capability, an external gate driver is required.

**8.3.17 SRA (7/14) and SRB (6/13)**

SRA and SRB are the synchronous rectifier control signals. With the 0.2A peak current capability, an external gate driver is required.

**8.3.18 GND (4/11)**

GND pin is the ground reference for the whole device. Tie all the signal returns to this pin.

**8.4 Device Functional Modes**

The UCC28251 can be controlled using either voltage mode or current mode. RAMP/CS is a multi-function pin used either to generate the ramp signal for voltage mode control or to sense current for current mode control. Please refer to [RAMP/CS \(PWM Ramp Input or Current Sense Input\) \(16/3\)](#) for the details.

## 9 Application and Implementation

### NOTE

Information in the following applications sections is not part of the TI component specification, and TI does not warrant its accuracy or completeness. TI's customers are responsible for determining suitability of components for their purposes. Customers should validate and test their design implementation to confirm system functionality.

### 9.1 Application Information

The UCC28251 is a high performance PWM controller with advanced synchronous rectifier outputs and is ideally suited for regulated half-bridge, full-bridge and push-pull converters. A dedicated internal pre-biased start up control loop working in conjunction with a primary-side voltage loop achieves monotonic pre-biased start up for either primary-side or secondary-side control applications. The UCC28251 architecture allows either voltage mode or current mode control.

Input voltage feedforward can be implemented, allowing PWM ramp generator to improve the converter line transient response. Advanced cycle-by-cycle current limit achieves volt-second balancing even during fault conditions. The hiccup timer helps the system to stay within a safe operation range under over load conditions. With a multifunction OVP/OTP pin, combinations of input voltage protection, output voltage protection and over temperature protection can be implemented. The UCC28251 allows individual programming of dead time between primary-side switch and secondary-side SRs, in order to allow optimal power stage design. Dead time can also be reduced to zero, and this allows optimal system configuration considering the delays on the gate driver stage. The UCC28251 also provides complete system level protection functions, including UVLO, thermal shut down and over voltage, over current protection.

#### 9.1.1 Error Amplifier and PWM Generation

The UCC28251 includes a high performance internal error amplifier with low input offset, high source/sink current capability and high gain bandwidth (typical 3.5 MHz). The reference of the error amplifier (REF/EA+ pin) is set externally to support flexible trimming of the voltage loop, and to make the controller flexible for both primary side, as well as secondary-side control. The extra positive input for the error amplifier is the SS pin which is used to externally program the soft-start time of the converter's output.

During steady state operation, the primary switch duty cycle,  $D$ , is generated based on the external ramp on RAMP/CS pin and the COMP pin voltage. A higher COMP pin voltage results in a larger duty cycle. The secondary-side SR duty cycle is  $SR\_D = (1-D)$ , complementary to the primary-side duty cycle, without considering the dead time between primary-side switch and secondary-side SR. The primary outputs begin to switch when COMP pin voltage is above the 420 mV internal offset. The synchronous rectifier outputs, SRA and SRB, follow after the primary outputs and have a minimum 50% duty cycle during startup. SRA and SRB continue to be active and will only be disabled when UCC28251 is disabled (either through UVLO, EN shut down, OVP and etc). According to the internal logic, the minimum pulse width for the primary-side OUTA and OUTB is typically 100 ns.

During soft start, the primary-side switch duty cycle is generated based on the external ramp on RAMP/CS pin and the COMP pin voltage. However, the duty cycle of secondary-side SR is generated based on an internal ramp and the COMP pin voltage. When the converter is controlled on the primary side, an internal ramp is a fixed ramp with 3-V peak voltage. When the converter is controlled on secondary side, an internal ramp is generated based on the internal pre-biased start-up loop. An internal pre-biased start-up loop modifies the SR duty cycle during soft start to achieve the optimal pre-biased start-up performance.

After the SS pin reaches 2.9 V, the pre-biased start-up control loop is disabled. The secondary-side SR instantaneously changes into its steady state value as complementary to the primary-side duty cycle.

#### 9.1.2 Prebiased Start Up

With the internal error amplifier, UCC28251 supports both primary-side control and secondary-side control. For different control methods, the controller is configured accordingly and so is the pre-biased start-up control. During soft start, both the primary-side switches' duty cycle and secondary-side SRs' duty cycle are increased. This gradually increases the output voltage until steady state operation is reached, thereby reducing surge current.

## Application Information (continued)

### 9.1.2.1 Secondary-Side Control

For secondary-side control, the UCC28251 implements close-loop control of both the primary-side switches and secondary-side synchronous rectifiers' duty cycles. This makes it easy to achieve optimal start up performance.

The internal error amplifier is set up as the control loop error amplifier. Connect REF/EA+, FB/EA-, COMP and VSENSE as shown in [Figure 39](#). To achieve optimal pre-biased start up performance, the output voltage needs to be directly measured. The UCC28251 uses the VSENSE pin to directly sense this output voltage. Choose the voltage dividers on VSENSE slightly different to the FB/EA- voltage divider so that the voltage on VSENSE pin is roughly 10% to 15% more than FB/EA- pin voltages. Select  $R_{O1}$  equal to  $R_{S1}$ , and  $R_{S2}$  about 10% to 15% smaller than  $R_{O2}$ .

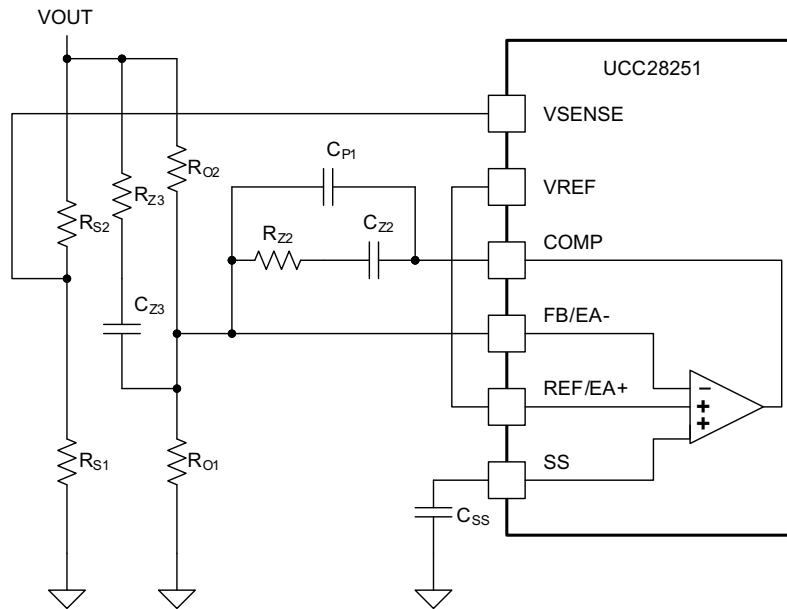

**Figure 39. Error Amplifier Set Up For Secondary-Side Control**

The error amplifier uses the lower voltage between the SS pin and the REF/EA+ pin to be the reference voltage for the feedback loop. In this method, the control loop is said to be 'closed' during the entire start up process, as it is always based on the true output voltage.

During soft start, the primary-side switch duty cycle is controlled by the COMP pin voltage and ramp voltage generated on the RAMP/CS pin. A higher COMP pin voltage results in larger duty cycle. However, to improve start up performance, the secondary-side synchronous rectifier duty cycle is controlled by a separate, internal ramp signal (generated by a dedicated pre-biased start up loop) and by the COMP pin voltage. This dedicated pre-biased loop is much faster than the regular voltage loop in order to avoid interaction between the two loops. The start up loop reads the output voltage via a transconductance error amplifier connected to the VSENSE pin. When the output voltage is higher than the reference, the pre-biased start up loop increases the SR duty cycle to reduce the output voltage. Conversely, when the output voltage is lower than the reference, the SR duty cycle is decreased to help maintain higher output voltage. To speed up the start up time, the minimum duty cycle of the synchronous rectifier is 50%.

Once the soft start is finished, the pre-biased loop is disabled and the duty cycle of the synchronous rectifiers becomes the complimentary of primary switches' duty cycle, with some dead time inserted in between.

### 9.1.2.2 Primary-Side Control

When the UCC28251 is sitting on the primary side, the internal error amplifier is connected as a voltage follower and an extra error amplifier is needed on the secondary side for closed loop control. The error amplifier implementation is shown in [Figure 40](#).

## Application Information (continued)

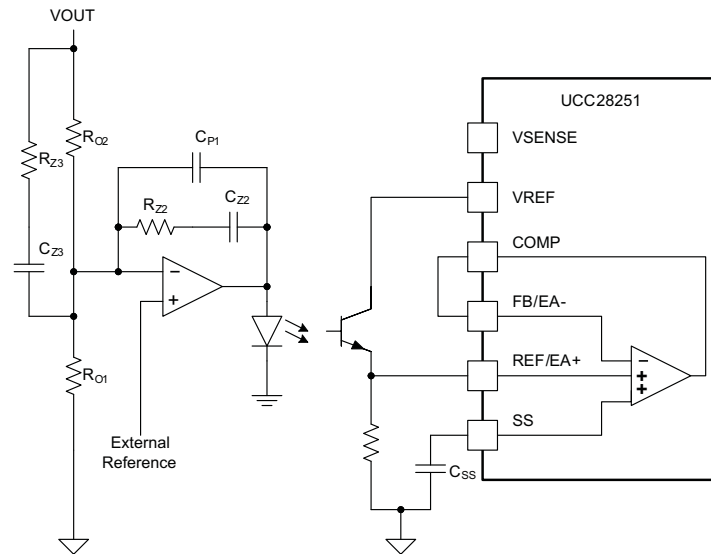

**Figure 40. Error Amplifier Setup for Primary-Side Control**

In the above configuration, the UCC28251 can only see the control loop feedback voltage, and cannot directly access the output voltage. The design of the soft-start time is critical to achieve optimal pre-biased start up performance. Some trial and error approaches are needed to achieve optimal performance. It is also important to choose the appropriate ramp amplitude. Refer to the ramp section discussion on the detailed design procedure for choosing ramp generation components.

During soft start, regardless of the pre-biased condition, the output voltage is always lower than the regulation voltage, so that the feedback loop is always saturated. When the internal error amplifier is connected as a voltage follower, the COMP voltage follows the lower of the voltage on the REF/EA+ pin and the SS pin. Since the feedback loop is saturated, the COMP pin always follows the SS pin voltage, until the output voltage becomes regulated and the feedback voltage takes over. In this control method, the output voltage control loop is always saturated, and the controller soft starts the COMP pin voltage. Therefore, it is called open loop soft start.

The primary-side switch duty cycle is controlled by the COMP pin voltage and by the RAMP/CS pin voltage. During soft start, the COMP pin voltage follows the SS pin as it is rising, so the primary-side switch duty cycle keeps increasing. When the output voltage becomes regulated, the feedback voltage becomes less than the SS pin voltage and the primary-side switch comes controlled by the control loop.

For the primary-side control setup, because output voltage is not directly accessible, the internal pre-biased start up loop is disabled by connecting VSENSE to VREF. Instead, the internal ramp used to generate the synchronous rectifier duty cycle is fixed, with the peak voltage of 3 V. The duty cycle of the synchronous rectifier increases as the SS pin voltage increases. When the SS pin voltage reaches 2.9 V, the soft start is considered finished and the synchronous rectifier duty cycle becomes the complementary of the primary-side switch duty cycle, minus the programmed dead time. Because of different COMP pin voltages at different line voltages, the SR duty cycle generated by the internal ramp might be different than the complementary of the primary-side switch duty cycle (1-D). If the duty cycle is too large, the internal logic is able to limit the duty cycle to (1-D). However, if the duty cycle is too small, when the soft start is finished, the SR duty cycle has a sudden change, which will cause output voltage disturbance. To optimize the pre-biased start up performance, it is recommended that the duty cycle change at the end of soft start be as small as possible.

### 9.1.3 Voltage Mode Control and Input Voltage Feed-Forward

For voltage mode control, a resistor  $R_{CS}$  and a capacitor  $C_{CS}$  are connected externally at RAMP/CS pin as shown in Figure 41. A ramp signal is generated on the RAMP/CS pin, at a rate of two times that of the switching frequency. The generated ramp signal is used to control the duty cycle for both the primary-side switches and secondary-side synchronous rectifiers. The ramp amplitude can be fixed or variable with the input voltage (input voltage feedforward).

## Application Information (continued)

To realize a fixed amplitude ramp, connect  $R_{CS}$  to the constant voltage source, so that the ramp capacitor charging voltage is fixed regardless of line and load condition. The RAMP/CS pin is clamped internally to 4 V for internal device protection. Because the internal pull-down switch has about 40- $\Omega$  on-resistance, the  $C_{CS}$  value must be small enough to discharge RAMP/CS from the peak to ground within  $T_{D(sp)} + 70$  ns (i.e. the pulse width of BLANK signal).

To achieve the input voltage feedforward, the slope of the ramp needs to be proportional to the input voltage. Tie  $R_{CS}$  to the input line voltage. Because the ramp voltage is much lower than the input voltage, the ramp capacitor charging current is considered to be proportional to the input voltage. With input voltage feedforward, the COMP pin voltage should only move slightly even with large input voltage variation. This will provide much better line transient response for the converter.

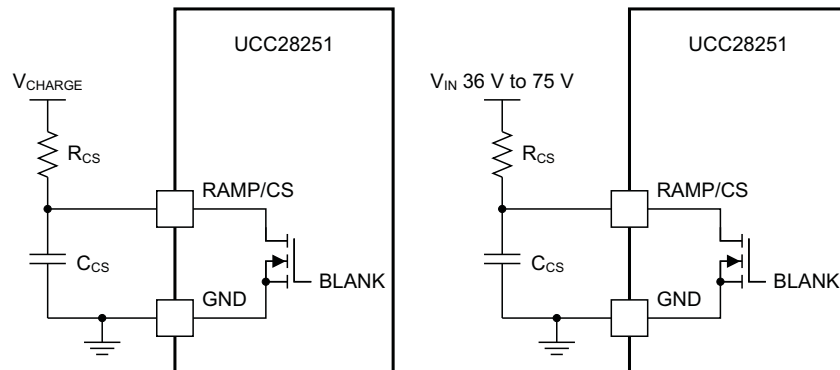

**Figure 41. External Configuration Of RAMP/CS Pin With/Without Feed-Forward Operation**

The input voltage feedforward also helps on pre-biased start up. When doing primary-side control to pre-biased start up, three conditions need to be considered:

### 9.1.3.1 Condition 1

At initial start up the primary side needs to provide enough energy to prevent output voltage dip;

### 9.1.3.2 Condition 2

At the end of soft start, it is required to keep the SR duty cycle change to be as small as possible. With input voltage feedforward, the COMP pin voltage is virtually fixed for different input voltages. Therefore, before the end of soft start, the duty cycle is the same for different input voltages. Choose the  $R_{CS}$  and  $C_{CS}$  following the procedure below.

Considering initial start up, the RAMP peak voltage should be:

$$V_{RAMP} = \frac{V_{IN} - V_{PRE-BIAS}}{2 \times n} \times V_{SR(ramp)} \quad (22)$$

In this equation,  $V_{IN}$  is the input voltage because of the feedforward any input voltage should be fine;  $V_{PRE-BIAS}$  is the highest pre-bias start-up voltage required by the system;  $n$  is the transformer primary to secondary turns ratio and  $V_{SR(ramp)}$  is the internal SR ramp peak voltage 3 V.

Another consideration is at the end of soft start, the SR duty cycle changes from controlled by the soft start, to complimentary to the primary-side duty cycle. The design should keep the transition as smooth as possible. Considering this, based on the output voltage and input voltage range, as well as the transformer turns ratio, calculate the SR duty cycle at different line voltages.

Next, based on the maximum duty cycle on the  $SR_{D_{MAX}}$ , and the internal fixed ramp amplitude 3 V, the COMP voltage at regulation can be chosen as:

$$V_{COMP(final)} = (SR_{D_{MAX}} - 0.5) \times 3 V \times 2 \quad (23)$$

## Application Information (continued)

### 9.1.3.3 Condition 3

Use the calculated COMP pin voltage to derive the external ramp amplitude

$$V_{RAMP} = \frac{V_{COMP(final)}}{(1 - SR_{D_{MAX}}) \times 2} \quad (24)$$

According to the calculated ramp voltage from Equation 22 and Equation 24 some trade off is required to pick up the appropriate ramp voltage. Based on the selected ramp capacitor  $C_{CS}$  value, choose the ramp resistor  $R_{CS}$  value:

$$R_{CS} = \frac{V_{IN(max)} \times 2}{V_{RAMP} \times C_{CS} \times f_{sw}} \quad (25)$$

In this equation,  $V_{IN(max)}$  is the maximum input voltage,  $f_{sw}$  is the switching frequency.

Because these calculations ignore the dead time and the non-linearity of the ramp, slight modification is expected to achieve the optimal design. When the input voltage feed forward is not used, refer to the RAMP pin discussion for RC calculation.

### 9.1.4 Peak Current Mode Control

For peak current mode control, RAMP/CS pin is connected directly with the current signal generated from a current transformer. The current signal must be compatible with the input range of the COMP pin. External slope compensation is required to prevent sub-harmonic oscillation and to maintain flux-balance. The slope compensation can be implemented by using OUTA and OUTB to charge external capacitors and use the voltage follower to add into the sensed the current signal, as shown in Figure 42. Follow the peak current mode control theory to select compensation slope or refer to *Modeling, Analysis and Compensation of the Current-Mode Converter (SLUA101)*.

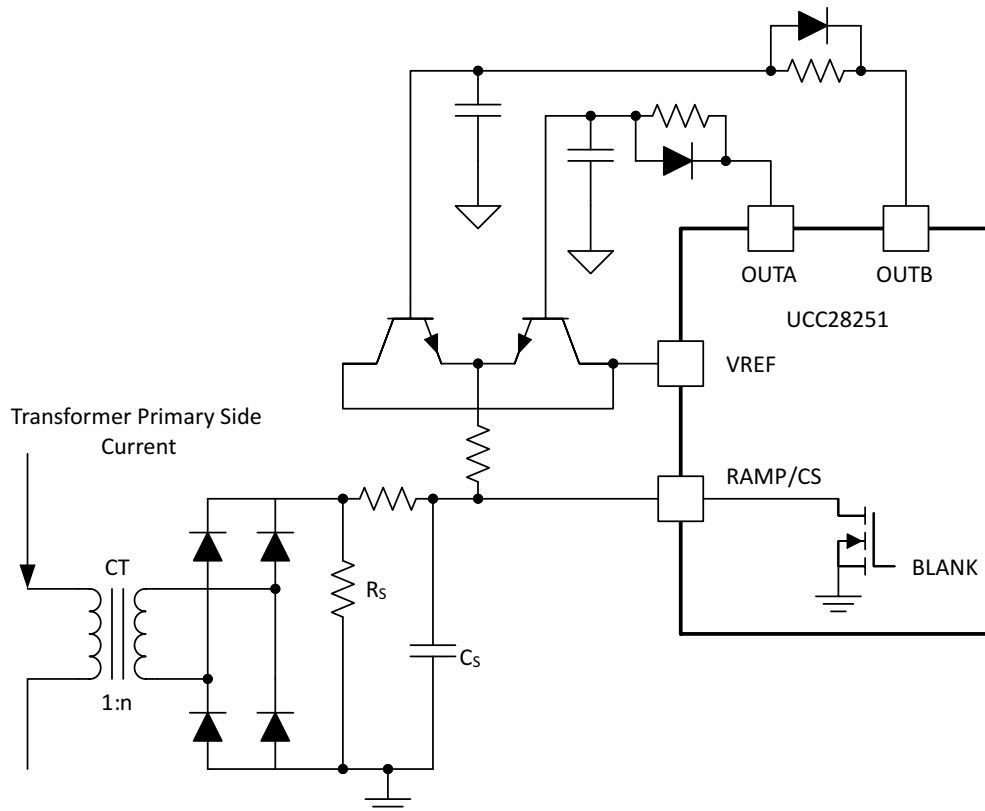

Figure 42. UCC28251 Set Up for Peak Current Mode Control

## Application Information (continued)

### 9.1.5 Cycle-by-Cycle Current Limit and Hiccup Mode Protection

Cycle-by-cycle current limit is accomplished using the ILIM pin for both current mode control and voltage mode control. The input to the ILIM pin represents the primary current information. If the voltage sensed at ILIM pin exceeds 0.5 V, the current sense comparator terminates the pulse of output OUTA or OUTB. If the high current condition persists, the controller operates in a cycle-by-cycle current limit mode with duty cycle determined by the current sense comparator instead of the PWM comparator. ILIM pin is pulled down by an internal switch at the rising edge of each clock cycle. This internal switch remains on for an additional 70 ns after OUTA or OUTB goes high to blank leading edge transient noise in the current sensing loop. This reduces the filtering requirements at the ILIM pin and improves the current sense response time.

UCC28251 makes it possible to maintain flux balance during cycle-by-cycle current limit operation. The duty cycles of primary switches are always matched. If one switch duty cycle is terminated earlier because of current limiting, a matched duty cycle is applied to the other switch for the next half switching cycle, regardless of the current condition, as shown in Figure 43. This matched duty cycle helps to maintain volt-second balancing on the transformer and prevents the transformer saturation.

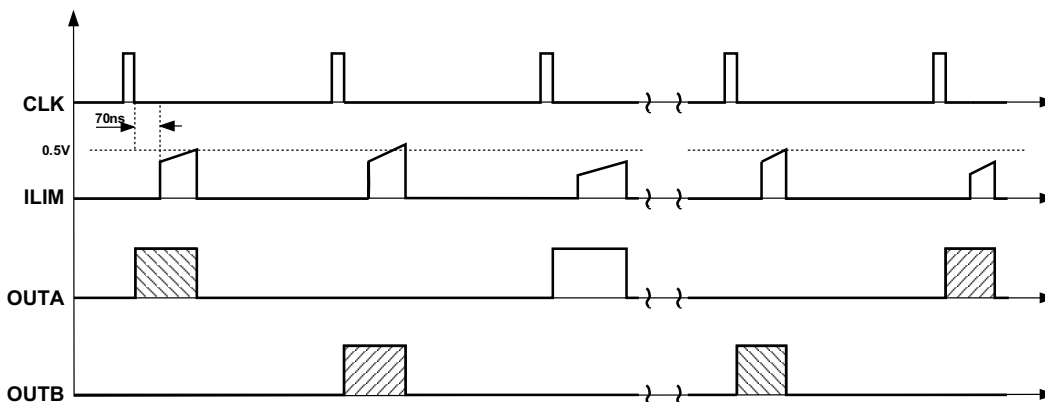

**Figure 43. Cycle-by-Cycle Current Limit Duty Cycle Matching**

Once the current limit is triggered, the 75- $\mu$ A internal current source begins to charge the capacitor on HICC pin. If the current limit condition went away before HICC pin reaches 0.6 V, the device stops charge HICC capacitor and begins to discharge it with 2.7- $\mu$ A current source. If the cycle-by-cycle current limit condition continues, HICC pin reaches 0.6 V, and all four outputs are shut down. The UCC28251 then enters hiccup mode. During hiccup mode, all four outputs keep low; SS pin is pulled to ground internally; a 2.7- $\mu$ A current source continuously discharge HICC pin capacitor; until HICC pin voltage reaches 0.3 V. After that, HICC pin is discharged internally to get ready for the next HICC event. The whole converter starts with soft start after hiccup mode.

The cycle-by-cycle current limit operation time before all four outputs shut down is programmed by external capacitor  $C_{\text{HICC}}$  at HICC pin. The delay time can be calculated as:

$$T_{\text{OC}(\text{delay})} = C_{\text{HICC}} \times \frac{0.6 \text{ V}}{75 \mu\text{A}} \quad (26)$$

The hiccup timer keeps all outputs being zero until the timer expires. The hiccup time  $T_{\text{HICC}}$  is calculated as:

$$T_{\text{HICC}} = C_{\text{HICC}} \times \frac{2.4 \text{ V} - 0.3 \text{ V}}{2.7 \mu\text{A}} \quad (27)$$

As soon as the outputs are shut-down, SS pin is pulled down internally until the hiccup restart timer is reset after time duration  $T_{\text{HICC}}$ . The detailed illustration of HICCUP mode is shown in Figure 44.

**Application Information (continued)**

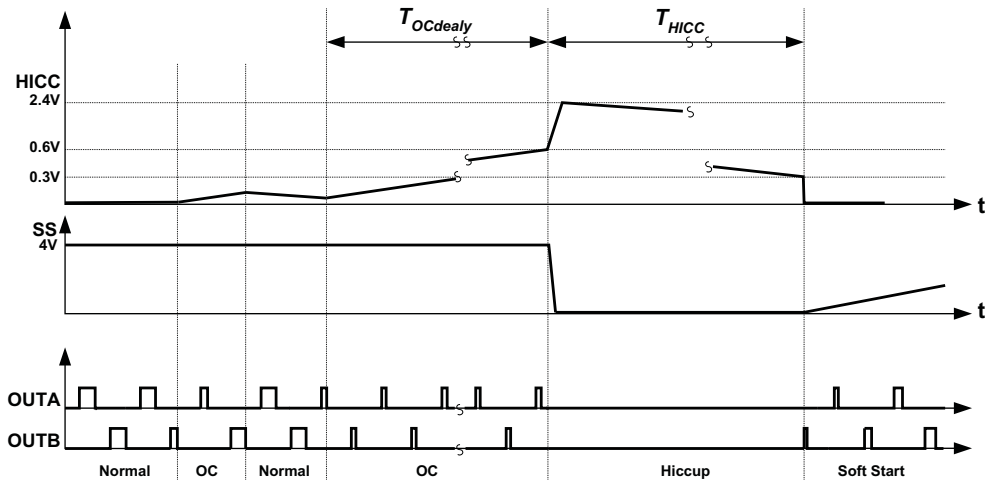

**Figure 44. Cycle-By-Cycle Current Limit Delay Timer and Hiccup Restart Timer**

**9.2 Typical Applications**

**9.2.1 Circuit Diagram in Design Example**

The example provided here is to show how to design a symmetrical half bridge converter of voltage mode control with UCC28251 on primary side.

Figure 45 is the circuit diagram to be used in this design example. This design example is to show how to determine the values in the circuit associated to UCC28251 programming.



## Typical Applications (continued)

### 9.2.1.1 Design Requirements

Table 2 shows the specifications for the design example.

**Table 2. Specifications for the Design Example**

PARAMETER		MIN	TYP	MAX	UNIT
V <sub>IN</sub>	Input voltage	36	48	72	VDC
V <sub>OUT</sub>	Output voltage		3.3		
P <sub>OUT</sub>	Output power			75	W
I <sub>OUT</sub>	Output load current			23	A
C <sub>OUT</sub>	Load capacitance			5000	μF
f <sub>SW</sub>	Switching frequency		150		kHz
P <sub>LIMIT</sub>	Over-power limit			150%	
η	Efficiency at full load		90%		
	Isolation	1500			V

### 9.2.1.2 Detailed Design Procedure

#### 9.2.1.2.1 Step 1: Power Stage Design

The power stage design in this example is standard and the same as that for symmetrical half bridge converter of voltage mode control. From the standard design, these components are determined. This includes Q1 through Q4, C1, C2, CT1, D1 and D2, D3, T1, T2 and T3, and U6. Their design is standard. Also, design associated to current sensing and protection is also standard. This includes CT1, D1, D2, R5 and C5.

#### 9.2.1.2.2 Step 2: Feedback Loop Design

D3 (TLV431) with U6, R6, R9, R10, R12, R13, C11 and C12 are composed of standard type 3 feedback loop compensation network and output voltage set point. Their design is also standard.

#### 9.2.1.2.3 Step 3: Programming The Device

##### 9.2.1.2.3.1 Step 3-1

Equation 3 is used to determine R<sub>T</sub> based on switching frequency, 300 kHz and assumes the dead time of 150 ns.

$$R_T = \frac{\frac{1}{2 \times 150 \text{ kHz}} - 150 \text{ ns}}{66.4 \text{ pF}} = \frac{3.18 \mu\text{s}}{66.4 \text{ pF}} = 47.9 \text{ k}\Omega$$

$$R_4 = 47.9 \text{ k}\Omega \quad (28)$$

##### 9.2.1.2.3.2 Step 3-2: Determine Ramp Resistance and Capacitance

There are two-fold considerations to determine RAMP resistance and capacitance. Equation 22 provides RAMP consideration for SR initial start up with prebias. The corresponding RAMP peak voltage is determined with input voltage low line and maximum prebias output voltage. In the below T1 turns ratio n = 4.

$$V_{\text{RAMP}} = \frac{V_{\text{IN}} - V_{\text{pre-bias}}}{2 \times V_{\text{pre-bias}}} \times V_{\text{SR\_RAMP}} = \frac{36 \text{ V} - 3.0 \text{ V}}{2 \times 3.0 \text{ V}} \times 3.0 \text{ V} = 0.750 \text{ V} \quad (29)$$

Equation 23 and Equation 24 provides RAMP consideration for soft start completion to make duty cycle match (1-D) = SR<sub>D</sub>.

1. Calculate OUTA or OUTB duty cycle at 75-V input voltage, 3.3-V output.

$$D = \frac{n \times V_O}{V_{IN}} \times \frac{1}{2} = \frac{4 \times 3.3 \text{ V}}{75 \text{ V}/2} \times \frac{1}{2} = 0.176 \quad (30)$$

2. Calculate SRA or SRB duty cycle.

$$SR\_D = 1 - D = 1 - 0.176 = 0.82 \quad (31)$$

3. Calculate the COMP voltage value in steady state (Equation 23).

$$V_{COMP} = (SR\_D - 0.5) \times 3.0 \text{ V} \times 2 = (0.824 - 0.5) \times 3.0 \text{ V} \times 2 = 1.944 \text{ V} \quad (32)$$

4. Calculate the RAMP peak value (Equation 24).

$$V_{RAMP} = \frac{V_{COMP}}{(D \times 2)} = \frac{1.944 \text{ V}}{(0.176 \times 2)} = 5.523 \text{ V} \quad (33)$$

5. Arbitrary select  $C_{RAMP}$  470 pF, then  $C3 = 470$  pF.

6. Calculate  $R_{RAMP}$ .

$$R_{RAMP\_1} = \frac{1}{2 \times \ln\left(\frac{V_{CHARGE}}{V_{CHARGE} - V_{RAMP}}\right) \times C_{RAMP} \times f_{sw}} = \frac{1}{2 \times \ln\left(\frac{36 \text{ V}}{36 \text{ V} - 0.750 \text{ V}}\right) \times 470 \text{ pF} \times 150 \text{ kHz}} = 336.9 \text{ k}\Omega \quad (34)$$

$$R_{RAMP\_2} = \frac{1}{2 \times \ln\left(\frac{V_{CHARGE}}{V_{CHARGE} - V_{RAMP}}\right) \times C_{RAMP} \times f_{sw}} = \frac{1}{2 \times \ln\left(\frac{75 \text{ V}}{75 \text{ V} - 5.523 \text{ V}}\right) \times 470 \text{ pF} \times 150 \text{ kHz}} = 92.7 \text{ k}\Omega \quad (35)$$

As different RAMP resistor values are obtained, at this stage, we may take their average value for initial design.

#### 9.2.1.2.4 Step 3-3: Determine Soft-Start Capacitance

Determine soft-start capacitance with soft-start time 15 ms.

$$C_{SS} = \frac{27 \mu\text{A} \times T_{SS}}{V_{COMP(\text{final})}} = \frac{27 \mu\text{A} \times 15 \text{ ms}}{4.0 \text{ V}} = 0.101 \mu\text{F} \Rightarrow C8 = 0.1 \mu\text{F} \quad (36)$$

#### 9.2.1.2.5 Step 3-4: Determine Dead-Time Resistance

Assuming the dead time is 150 ns, Select  $R7 = R8 = 121$  k $\Omega$  based on Figure 27 and Figure 28.

#### 9.2.1.2.6 Step 3-5: Determine OCP Hiccup Off-Time Capacitance

Assuming off time is 0.8 s (Equation 14).

$$C_{HICC} = T_{HICC} \times \frac{2.7 \mu\text{A}}{2.4 \text{ V} - 0.3 \text{ V}} = 0.8 \text{ s} \times \frac{2.7 \mu\text{A}}{2.4 \text{ V} - 0.3 \text{ V}} = 1.03 \mu\text{F} \Rightarrow C7 = 1.0 \mu\text{F} \quad (37)$$

#### 9.2.1.2.7 Step 3-6: Determine Primary-Side OVP Resistance

Assuming  $OV\_OFF = 73$  V,  $OV\_ON = 72$  V (Equation 15 to Equation 17).

$$R_2 \leq \frac{0.7 \text{ V} \times (V_r - V_f)}{11 \mu\text{A} \times (V_r - 0.7 \text{ V})} = \frac{0.7 \text{ V} \times (73 \text{ V} - 72 \text{ V})}{11 \mu\text{A} \times (73 \text{ V} - 0.7 \text{ V})} = 880 \Omega \Rightarrow R2 = 866 \Omega \quad (38)$$

$$R_1 = \frac{V_R - 0.7 \text{ V}}{0.7 \text{ V}} \times R_2 = \frac{73 \text{ V} - 0.7 \text{ V}}{0.7 \text{ V}} \times 866 \Omega = 89.4 \text{ k}\Omega \Rightarrow R1 = 88.7 \text{ k}\Omega \quad (39)$$

$$\begin{aligned}
 R_3 &= \frac{0.7\text{ V} \times (V_R - V_F) - 11\mu\text{A} \times R_2 \times (V_R - 0.7\text{ V})}{11\mu\text{A} \times V_r} = \\
 &= \frac{0.7\text{ V} \times (73\text{ V} - 72\text{ V}) - 11\mu\text{A} \times 866\Omega \times (73\text{ V} - 0.7\text{ V})}{11\mu\text{A} \times 73\text{ V}} = 14\Omega \Rightarrow R14 = 14\Omega
 \end{aligned}
 \tag{40}$$

#### 9.2.1.2.8 Step 3-7: Select Capacitance for VDD and VREF

As recommended by the datasheet, select  $C6 = C4 = 1.0\ \mu\text{F}$ . The final design is shown in [Figure 46](#).

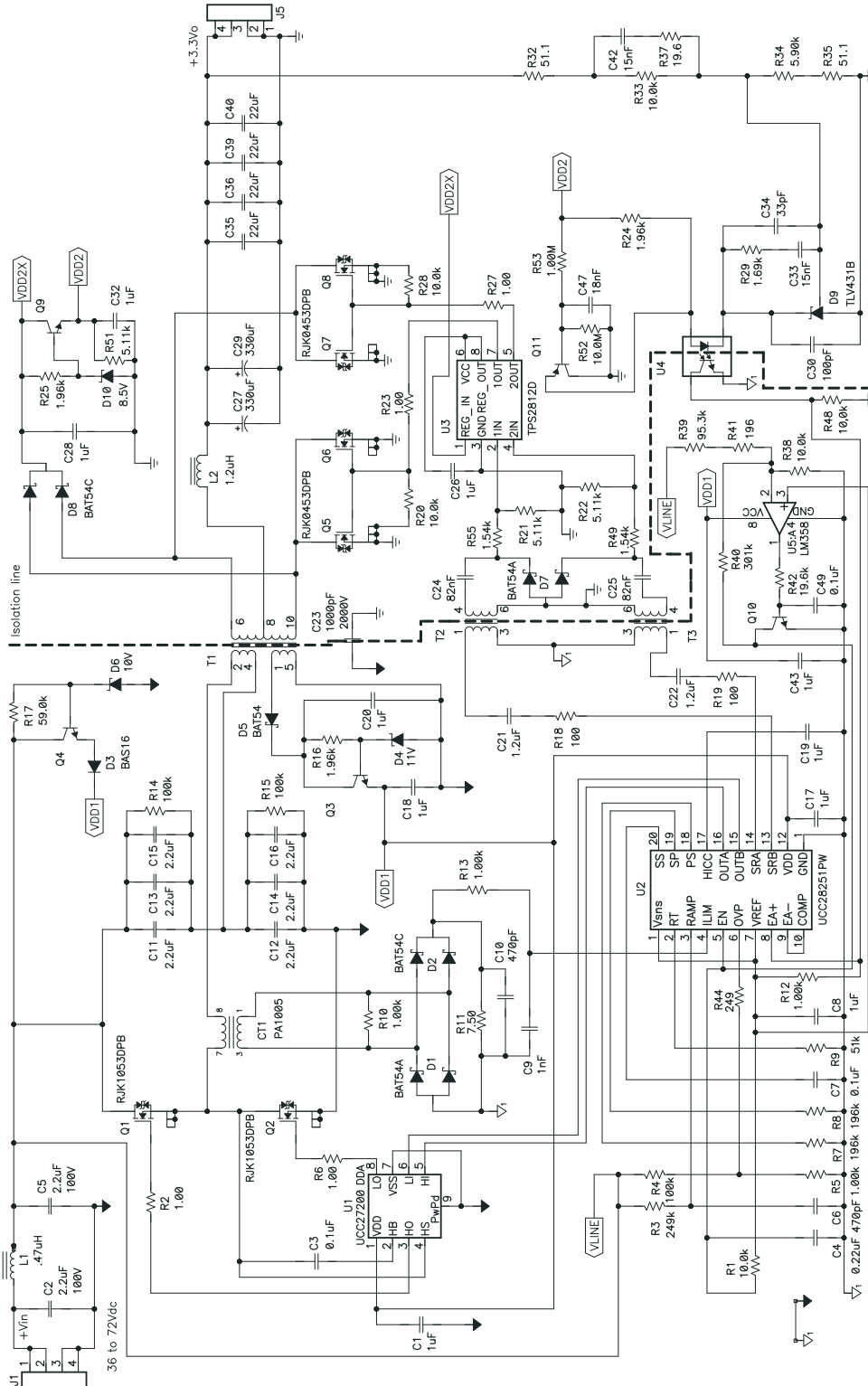
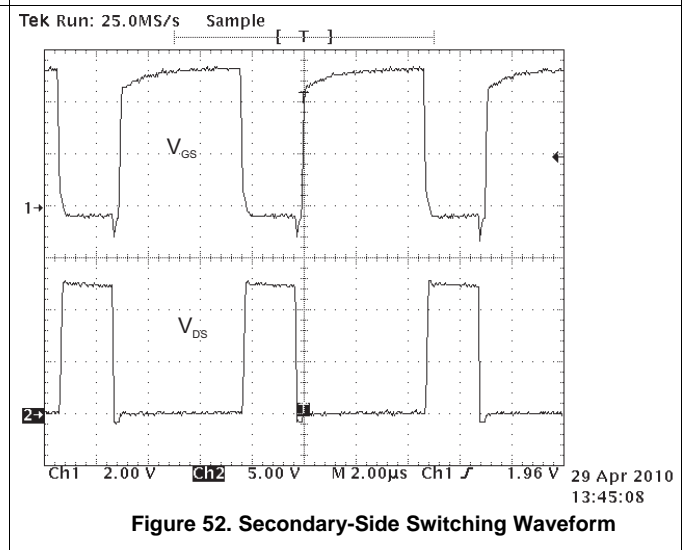
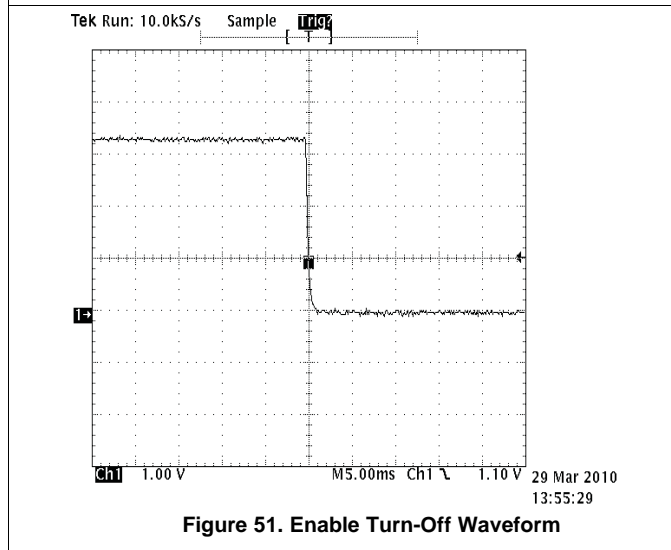
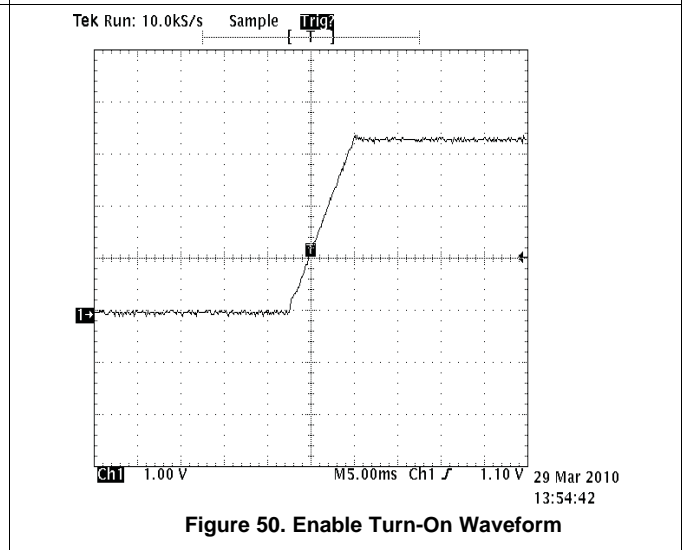
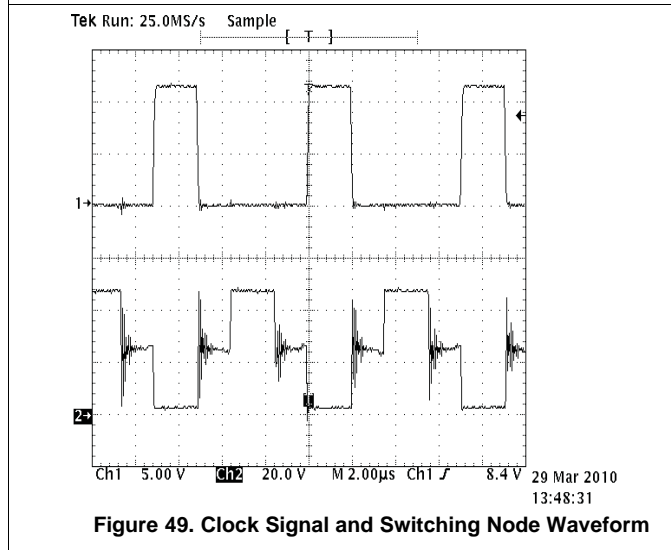
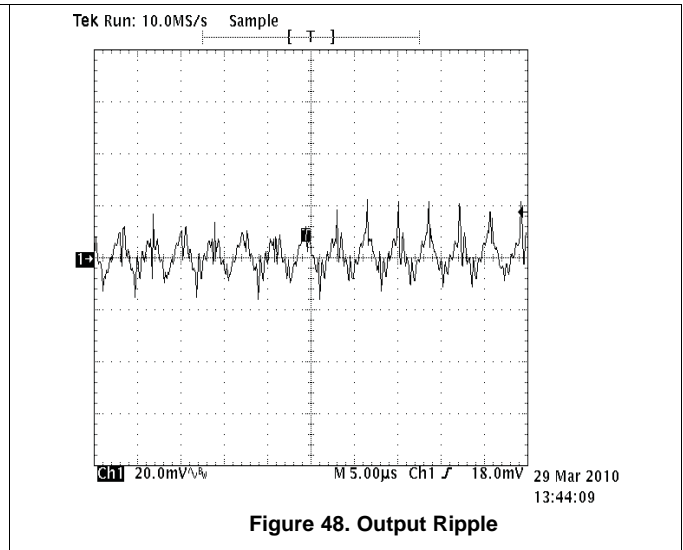
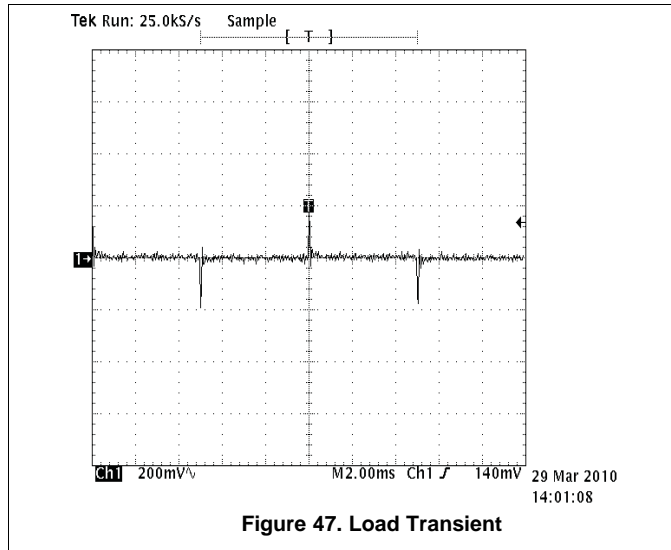

Figure 46. Schematics of Primary-Side Control Design Example

9.2.1.3 Application Curves



### 9.2.2 Secondary-Side Half-Bridge Controller With Synchronous Rectification

UCC28250 also supports secondary-side control. Refer to [Figure 53](#). In this configuration, the UCC28250 can be used in a design that produces smooth turn-on performance with an output pre-bias condition. The design example and guidelines are summarized in *Designing UCC28250 as a Secondary Side Control for Output Turn-On with a Pre-Bias Condition*, [SLAA477](#), and *Using the UCC28250EVM-564*, [SLUU441](#).

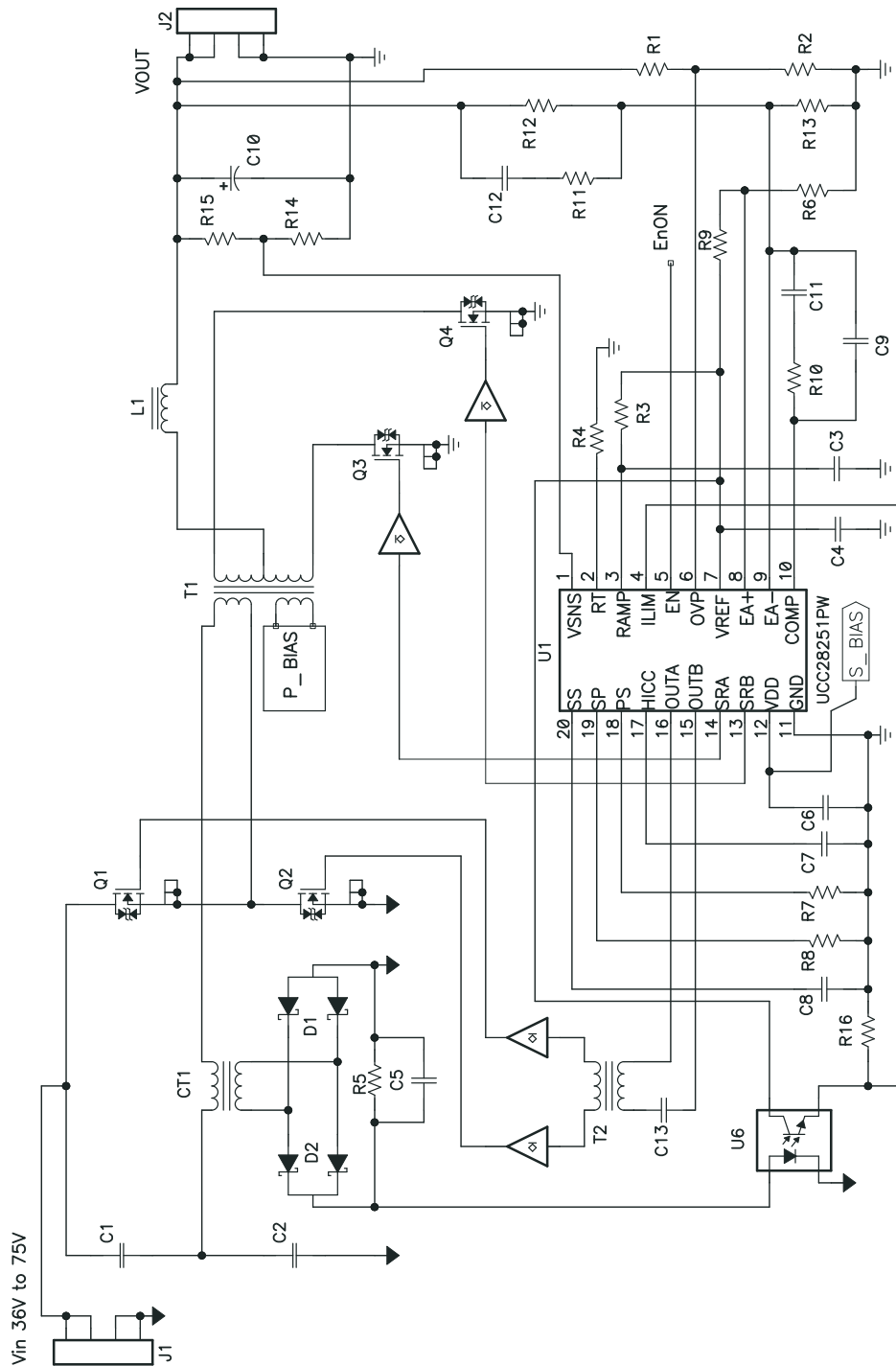

**Figure 53. Secondary-Side Half-Bridge Controller With Synchronous Rectification**

## 10 Power Supply Recommendations

The COMP pin is the internal error amplifier's output and also the input signal for PWM comparator. The maximum input common voltage of the PWM comparator is 2.8 V. It is suggested to program the peak value of RAMP to be lower than 2.3 V. Otherwise, the voltage of COMP pin should be clamp to be lower than 2.8 V by external circuit in order to make the internal PWM comparator work properly. Please refer to [COMP \(3/10\)](#) for the detail information.

## 11 Layout

### 11.1 Layout Guidelines

In order to increase the reliability and robustness of the design, it is recommended that the following layout guidelines be met.

1. REF/EA+ The REF/EA+ pin is the non-inverting input of the error amplifier. For secondary side control, this pin is used to set the reference of voltage loop which decides the output voltage. So it is important to keep it clear from any of high voltage switching nodes. In addition, a decoupling capacitor located closely is recommended. For primary side control, this pin needs to be connected to opto-coupler. it is important minimize the loop area by running the EA+ signal and GND trace in parallel.
2. FB/EA- Please minimize the loop between FB/EA- and COMP and keep it clear from any of high voltage switch nodes in order to avoid the noise injection into to the compensation loop.
3. COMP Please minimize the loop between FB/EA- and COMP and keep it clear from any of high voltage switch nodes in order to avoid the noise injection into to the compensation loop.
4. GND As with all PWM controllers, the effectiveness of the filter capacitors on the signal pins depends upon the integrity of the ground return. Place all decoupling and filter capacitors as close as possible to the device pins with short traces. The AGND pin is used as the return connection for the low-power signaling and sensitive signal so it should be separated from the power stage ground to avoid ground bouncing.
5. VDD, VREF The VCC pin must be decoupled to GND by minimum 1- $\mu$ F ceramic capacitors placed close to the pins.
6. SRA, SRB, OUTA, OUTB The SRA and SRB gate drive pins can be used to drive the inputs of gate driver or to directly drive the primary winding of a gate-drive transformer or the to directly drive the input of isolator. The tracks connected to these pins carry high dv/dt signals. Minimize noise pickup by routing them as far away as possible from tracks connected to sensitive signal including EA+, EA-, COMP, VSENSE, RT, RAMP/CS, ILIM, PS, SP.
7. HICC, SS, EN, OVP/OTP The connection track between the pin and external corresponding capacitor should be short.
8. PS, SP, RT, VSENSE, RAMP/CS, ILIM These pins are noise sensitive so please allocate related resistor as close as possible with the good ground connection.

## 11.2 Layout Example

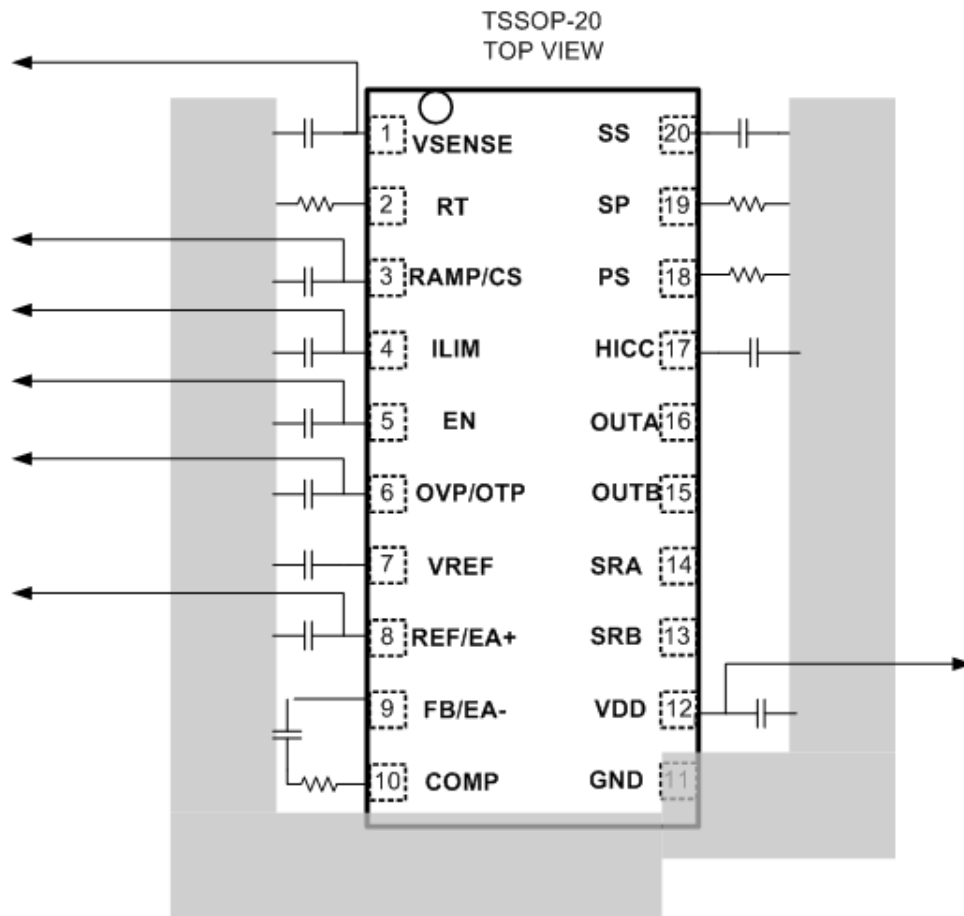

**Figure 54. Layout Example**

## 11.3 Thermal Protection

Internal thermal shutdown circuitry protects the UCC28251 in the event the maximum rated junction temperature is exceeded. When activated, typically at 160 °C, with the maximum threshold at 170 °C and minimum threshold at 150 °C the controller is forced into a low power standby mode. The outputs (OUTA, OUTB, SRA, SRB) are disabled. This helps to prevent accidental device overheating. A 20 °C hysteresis is added to prevent comparator oscillation. During thermal shutdown, the UCC28251 follows a normal start up sequence after the junction temperature falls below 140 °C (typical value, with 130 °C minimum threshold and 150 °C maximum threshold).

## 12 器件和文档支持

### 12.1 文档支持

#### 12.1.1 相关文档

相关文档请参见以下部分：

- 《将 UCC28250 设计为二次侧控制器以控制预偏置条件下的输出导通》，[SLAA477](#)
- 《使用 UCC28250EVM-564》，[SLUU441](#)

### 12.2 商标

All trademarks are the property of their respective owners.

### 12.3 静电放电警告



这些装置包含有限的内置 ESD 保护。存储或装卸时，应将导线一起截短或将装置放置于导电泡棉中，以防止 MOS 门极遭受静电损伤。

### 12.4 Glossary

[SLYZ022](#) — *TI Glossary*.

This glossary lists and explains terms, acronyms, and definitions.

## 13 机械、封装和可订购信息

以下页中包括机械、封装和可订购信息。这些信息是针对指定器件可提供的最新数据。这些数据会在无通知且不对本文档进行修订的情况下发生改变。欲获得该数据表的浏览器版本，请查阅左侧的导航栏

**PACKAGING INFORMATION**

Orderable Device	Status (1)	Package Type	Package Drawing	Pins	Package Qty	Eco Plan (2)	Lead finish/ Ball material (6)	MSL Peak Temp (3)	Op Temp (°C)	Device Marking (4/5)	Samples
UCC28251PW	ACTIVE	TSSOP	PW	20	70	RoHS & Green	NIPDAU	Level-1-260C-UNLIM	-40 to 125	UCC28251	<a href="#">Samples</a>
UCC28251PWR	ACTIVE	TSSOP	PW	20	2000	RoHS & Green	NIPDAU	Level-1-260C-UNLIM	-40 to 125	UCC28251	<a href="#">Samples</a>
UCC28251RGPR	ACTIVE	QFN	RGP	20	3000	RoHS & Green	NIPDAU	Level-2-260C-1 YEAR	-40 to 125	28251	<a href="#">Samples</a>
UCC28251RGPT	ACTIVE	QFN	RGP	20	250	RoHS & Green	NIPDAU	Level-2-260C-1 YEAR	-40 to 125	28251	<a href="#">Samples</a>

(1) The marketing status values are defined as follows:

**ACTIVE:** Product device recommended for new designs.

**LIFEBUY:** TI has announced that the device will be discontinued, and a lifetime-buy period is in effect.

**NRND:** Not recommended for new designs. Device is in production to support existing customers, but TI does not recommend using this part in a new design.

**PREVIEW:** Device has been announced but is not in production. Samples may or may not be available.

**OBSOLETE:** TI has discontinued the production of the device.

(2) **RoHS:** TI defines "RoHS" to mean semiconductor products that are compliant with the current EU RoHS requirements for all 10 RoHS substances, including the requirement that RoHS substance do not exceed 0.1% by weight in homogeneous materials. Where designed to be soldered at high temperatures, "RoHS" products are suitable for use in specified lead-free processes. TI may reference these types of products as "Pb-Free".

**RoHS Exempt:** TI defines "RoHS Exempt" to mean products that contain lead but are compliant with EU RoHS pursuant to a specific EU RoHS exemption.

**Green:** TI defines "Green" to mean the content of Chlorine (Cl) and Bromine (Br) based flame retardants meet JS709B low halogen requirements of <=1000ppm threshold. Antimony trioxide based flame retardants must also meet the <=1000ppm threshold requirement.

(3) MSL, Peak Temp. - The Moisture Sensitivity Level rating according to the JEDEC industry standard classifications, and peak solder temperature.

(4) There may be additional marking, which relates to the logo, the lot trace code information, or the environmental category on the device.

(5) Multiple Device Markings will be inside parentheses. Only one Device Marking contained in parentheses and separated by a "-" will appear on a device. If a line is indented then it is a continuation of the previous line and the two combined represent the entire Device Marking for that device.

(6) Lead finish/Ball material - Orderable Devices may have multiple material finish options. Finish options are separated by a vertical ruled line. Lead finish/Ball material values may wrap to two lines if the finish value exceeds the maximum column width.

**Important Information and Disclaimer:**The information provided on this page represents TI's knowledge and belief as of the date that it is provided. TI bases its knowledge and belief on information provided by third parties, and makes no representation or warranty as to the accuracy of such information. Efforts are underway to better integrate information from third parties. TI has taken and

continues to take reasonable steps to provide representative and accurate information but may not have conducted destructive testing or chemical analysis on incoming materials and chemicals. TI and TI suppliers consider certain information to be proprietary, and thus CAS numbers and other limited information may not be available for release.

In no event shall TI's liability arising out of such information exceed the total purchase price of the TI part(s) at issue in this document sold by TI to Customer on an annual basis.

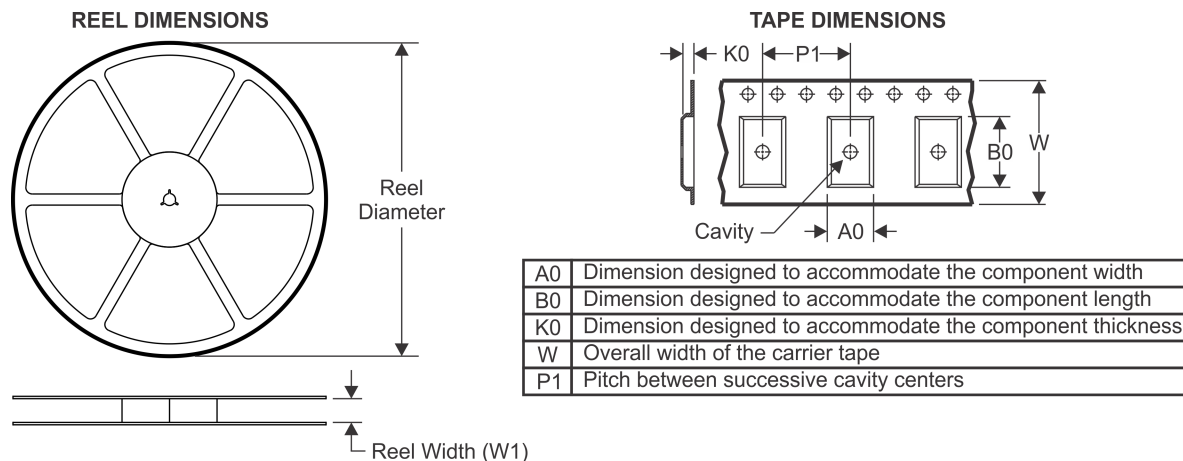
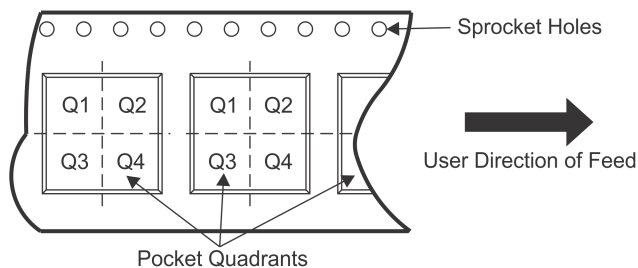
**TAPE AND REEL INFORMATION**

**QUADRANT ASSIGNMENTS FOR PIN 1 ORIENTATION IN TAPE**

\*All dimensions are nominal

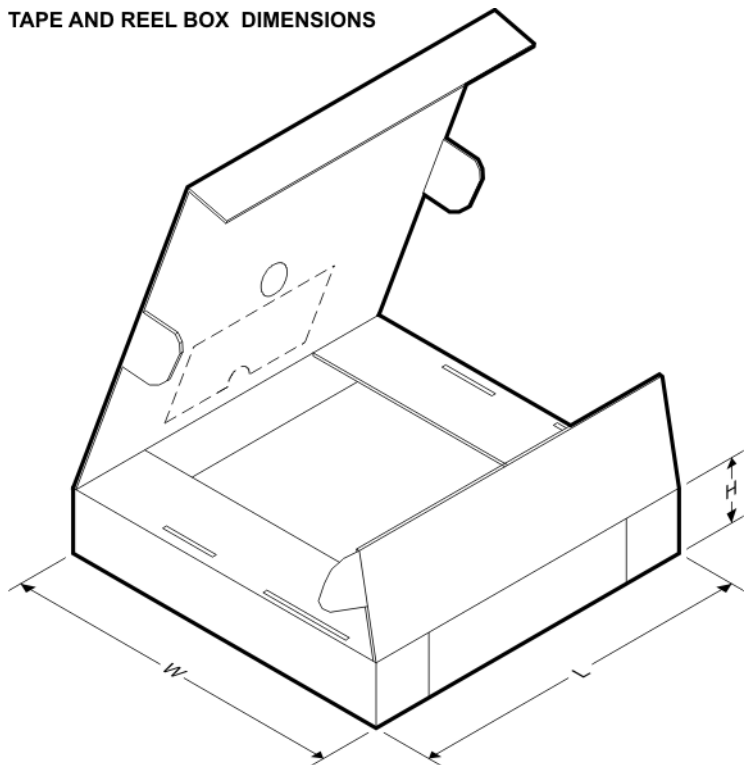
Device	Package Type	Package Drawing	Pins	SPQ	Reel Diameter (mm)	Reel Width W1 (mm)	A0 (mm)	B0 (mm)	K0 (mm)	P1 (mm)	W (mm)	Pin1 Quadrant
UCC28251PWR	TSSOP	PW	20	2000	330.0	16.4	6.95	7.1	1.6	8.0	16.0	Q1
UCC28251RGPR	QFN	RGP	20	3000	330.0	12.4	4.25	4.25	1.15	8.0	12.0	Q2
UCC28251RGPT	QFN	RGP	20	250	180.0	12.4	4.25	4.25	1.15	8.0	12.0	Q2

**TAPE AND REEL BOX DIMENSIONS**

\*All dimensions are nominal

Device	Package Type	Package Drawing	Pins	SPQ	Length (mm)	Width (mm)	Height (mm)
UCC28251PWR	TSSOP	PW	20	2000	853.0	449.0	35.0
UCC28251RGPR	QFN	RGP	20	3000	367.0	367.0	35.0
UCC28251RGPT	QFN	RGP	20	250	210.0	185.0	35.0

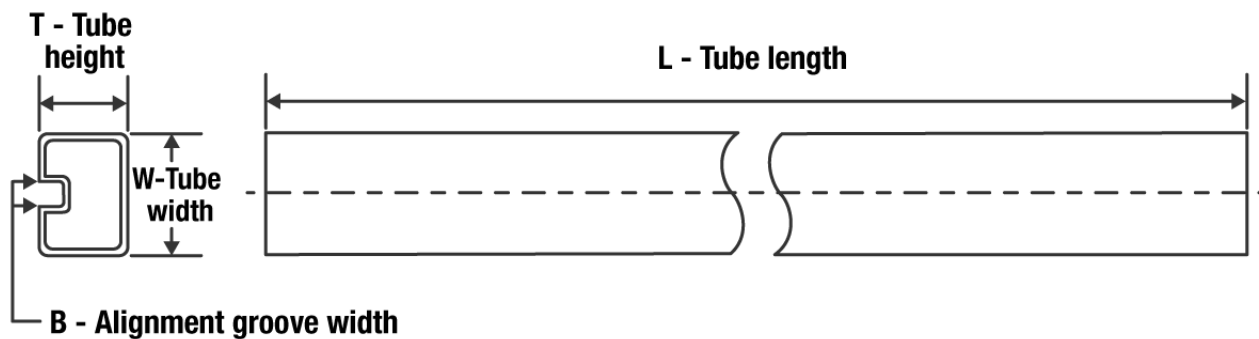
**TUBE**

\*All dimensions are nominal

Device	Package Name	Package Type	Pins	SPQ	L (mm)	W (mm)	T (μm)	B (mm)
UCC28251PW	PW	TSSOP	20	70	530	10.2	3600	3.5

# PW0020A

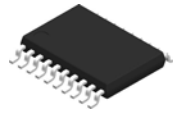

# PACKAGE OUTLINE

## TSSOP - 1.2 mm max height

SMALL OUTLINE PACKAGE

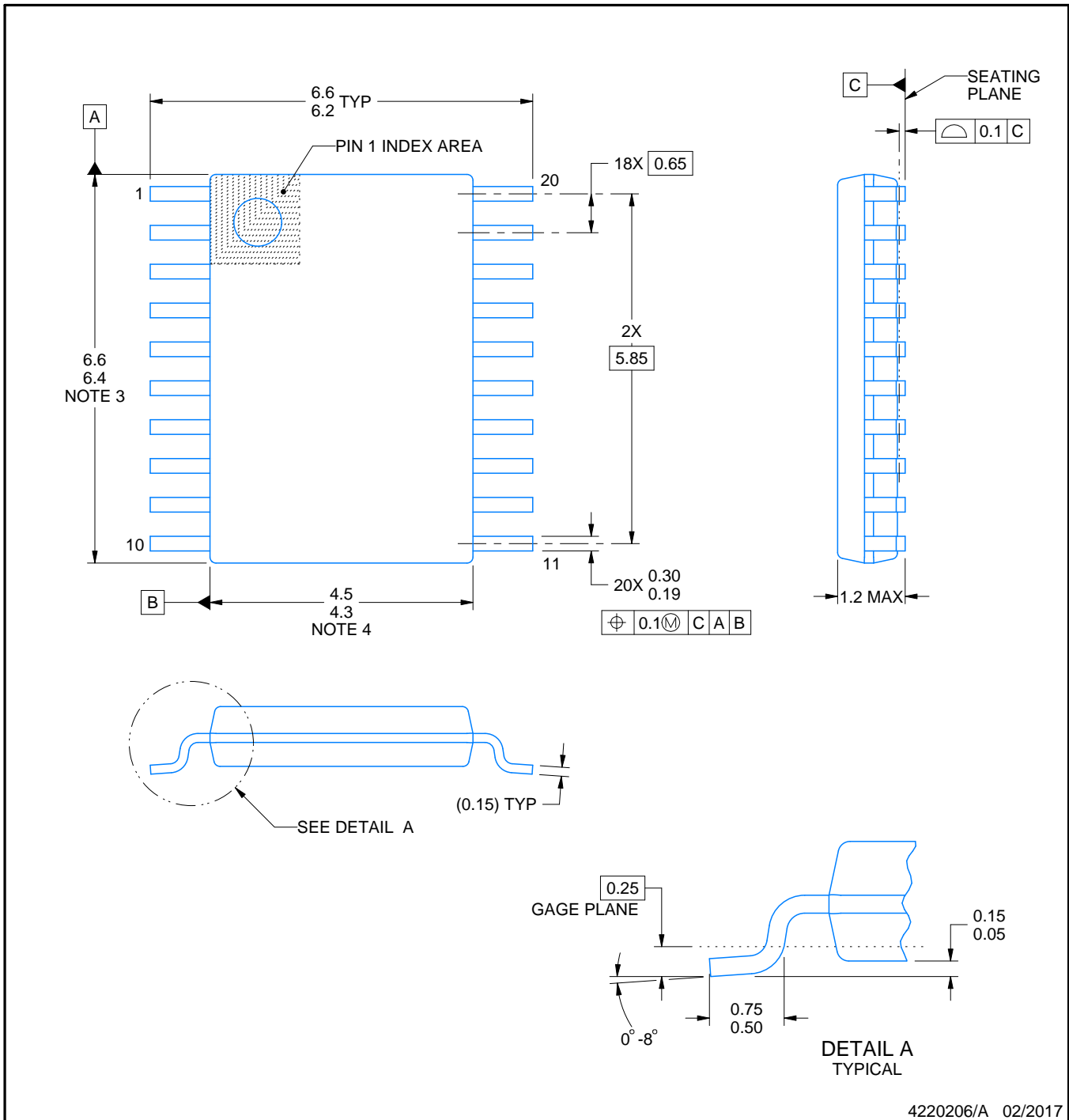

4220206/A 02/2017

### NOTES:

1. All linear dimensions are in millimeters. Any dimensions in parenthesis are for reference only. Dimensioning and tolerancing per ASME Y14.5M.
2. This drawing is subject to change without notice.
3. This dimension does not include mold flash, protrusions, or gate burrs. Mold flash, protrusions, or gate burrs shall not exceed 0.15 mm per side.
4. This dimension does not include interlead flash. Interlead flash shall not exceed 0.25 mm per side.
5. Reference JEDEC registration MO-153.

# EXAMPLE BOARD LAYOUT

PW0020A

TSSOP - 1.2 mm max height

SMALL OUTLINE PACKAGE

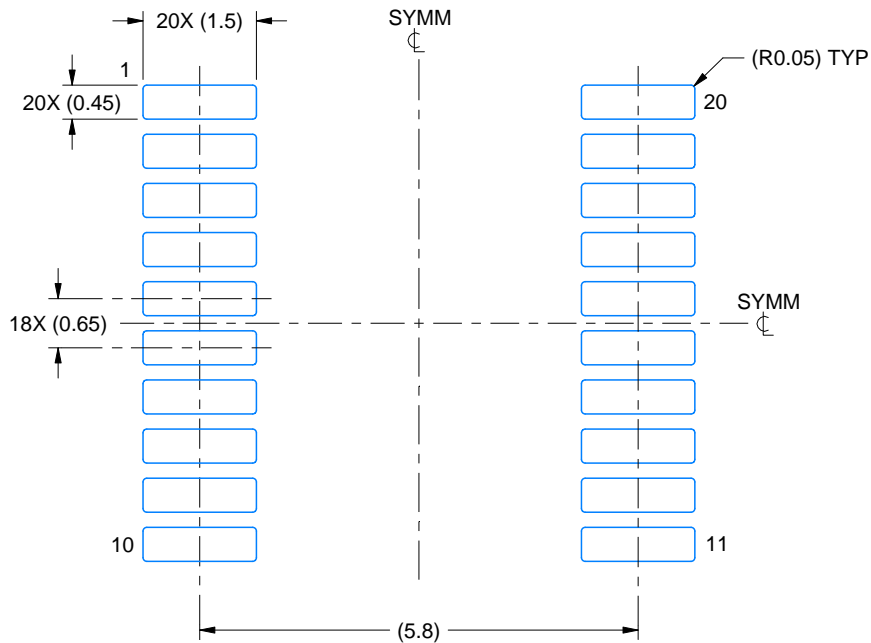

LAND PATTERN EXAMPLE  
EXPOSED METAL SHOWN  
SCALE: 10X

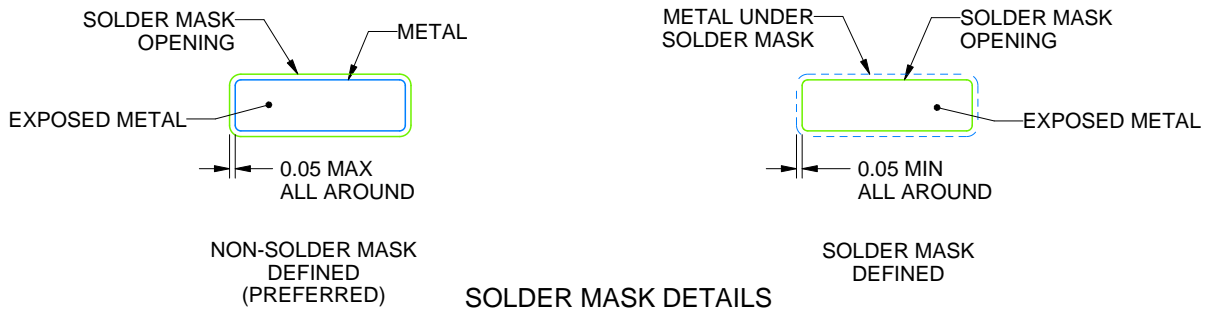

4220206/A 02/2017

NOTES: (continued)

- 6. Publication IPC-7351 may have alternate designs.
- 7. Solder mask tolerances between and around signal pads can vary based on board fabrication site.

# EXAMPLE STENCIL DESIGN

PW0020A

TSSOP - 1.2 mm max height

SMALL OUTLINE PACKAGE

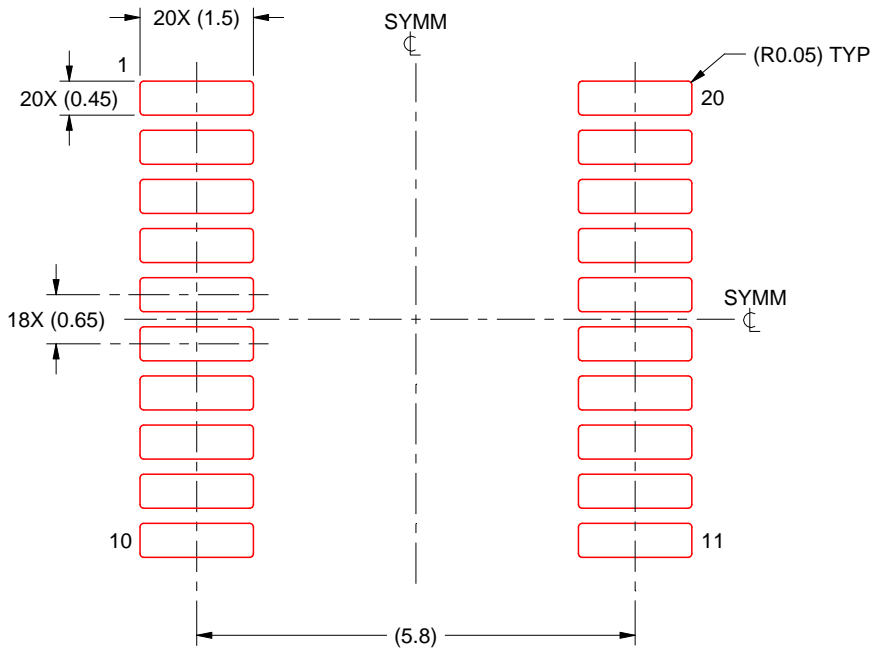

SOLDER PASTE EXAMPLE  
BASED ON 0.125 mm THICK STENCIL  
SCALE: 10X

4220206/A 02/2017

NOTES: (continued)

8. Laser cutting apertures with trapezoidal walls and rounded corners may offer better paste release. IPC-7525 may have alternate design recommendations.
9. Board assembly site may have different recommendations for stencil design.

PW (R-PDSO-G20)

PLASTIC SMALL OUTLINE

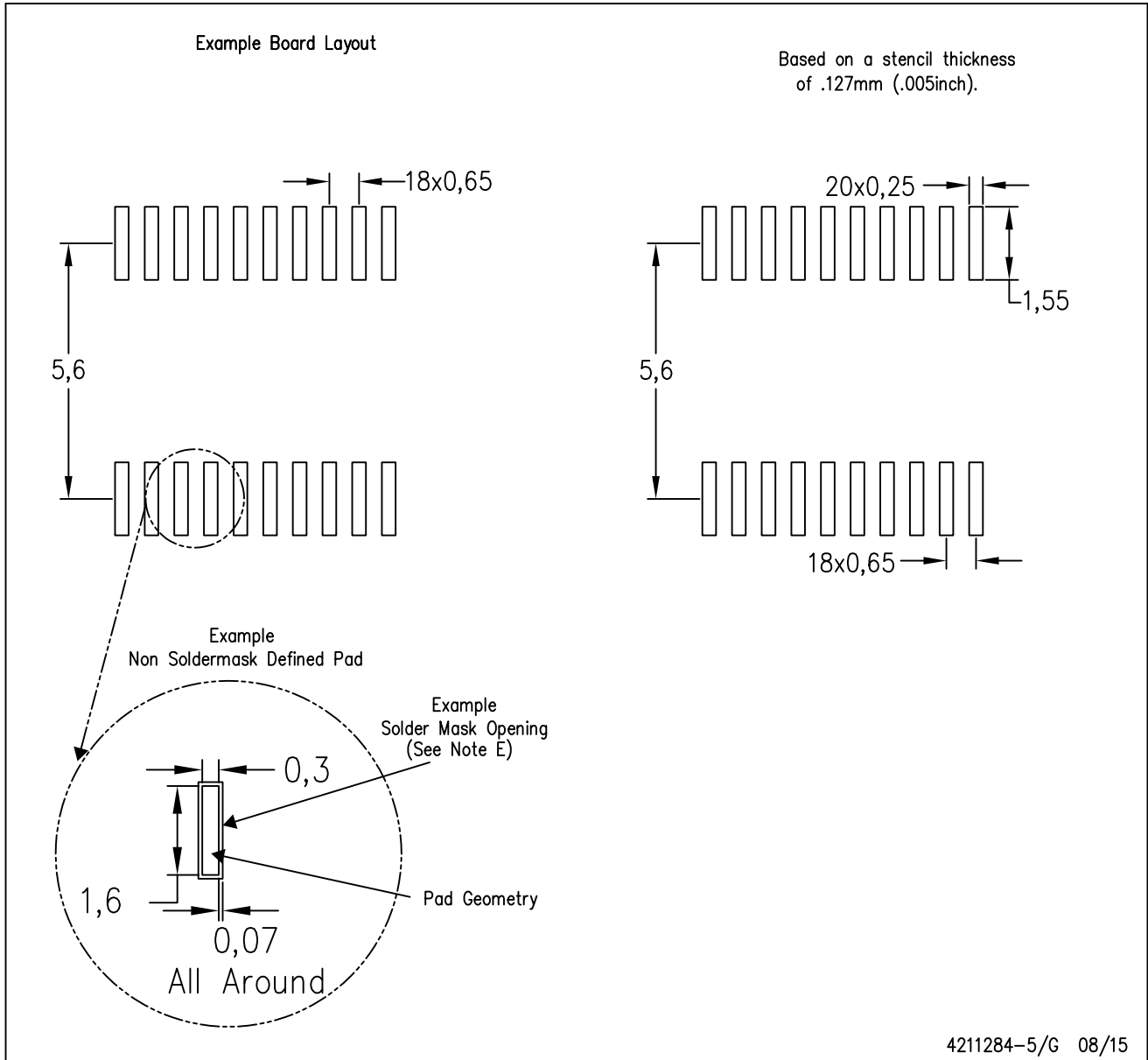

- NOTES:
- A. All linear dimensions are in millimeters.
  - B. This drawing is subject to change without notice.
  - C. Publication IPC-7351 is recommended for alternate design.
  - D. Laser cutting apertures with trapezoidal walls and also rounding corners will offer better paste release. Customers should contact their board assembly site for stencil design recommendations. Refer to IPC-7525 for other stencil recommendations.
  - E. Customers should contact their board fabrication site for solder mask tolerances between and around signal pads.

## GENERIC PACKAGE VIEW

**RGP 20**

**VQFN - 1 mm max height**

4 x 4, 0.5 mm pitch

VERY THIN QUAD FLATPACK

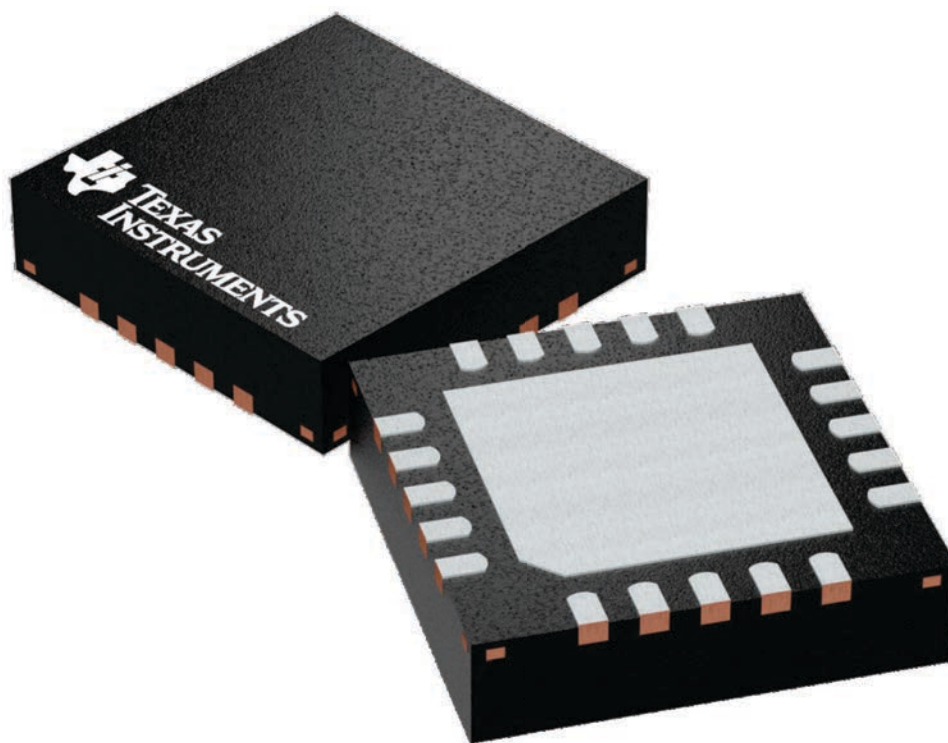

Images above are just a representation of the package family, actual package may vary.  
Refer to the product data sheet for package details.

4224735/A

RGP (S-PVQFN-N20)

PLASTIC QUAD FLATPACK NO-LEAD

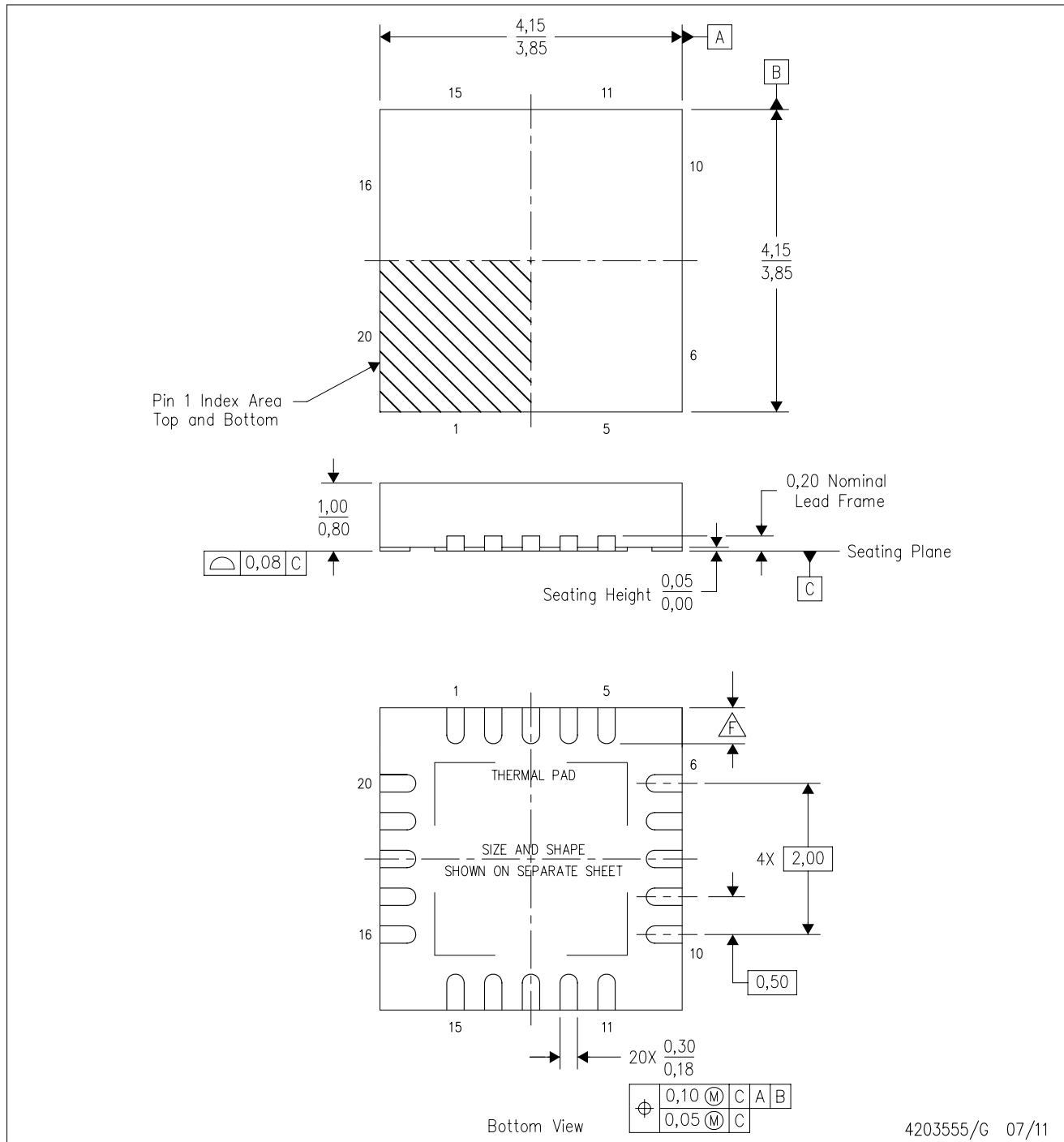

- NOTES:
- All linear dimensions are in millimeters. Dimensioning and tolerancing per ASME Y14.5M-1994.
  - This drawing is subject to change without notice.
  - QFN (Quad Flatpack No-Lead) package configuration.
  - The package thermal pad must be soldered to the board for thermal and mechanical performance.
  - See the additional figure in the Product Data Sheet for details regarding the exposed thermal pad features and dimensions.
- Check thermal pad mechanical drawing in the product datasheet for nominal lead length dimensions.

# THERMAL PAD MECHANICAL DATA

RGP (S-PVQFN-N20)

PLASTIC QUAD FLATPACK NO-LEAD

## THERMAL INFORMATION

This package incorporates an exposed thermal pad that is designed to be attached directly to an external heatsink. The thermal pad must be soldered directly to the printed circuit board (PCB). After soldering, the PCB can be used as a heatsink. In addition, through the use of thermal vias, the thermal pad can be attached directly to the appropriate copper plane shown in the electrical schematic for the device, or alternatively, can be attached to a special heatsink structure designed into the PCB. This design optimizes the heat transfer from the integrated circuit (IC).

For information on the Quad Flatpack No-Lead (QFN) package and its advantages, refer to Application Report, QFN/SON PCB Attachment, Texas Instruments Literature No. SLUA271. This document is available at [www.ti.com](http://www.ti.com).

The exposed thermal pad dimensions for this package are shown in the following illustration.

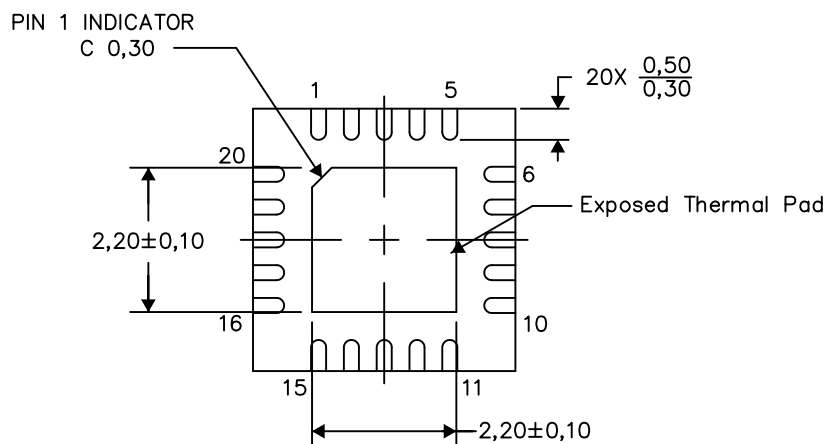

Bottom View

Exposed Thermal Pad Dimensions

4206346-4/AA 11/13

NOTES: A. All linear dimensions are in millimeters

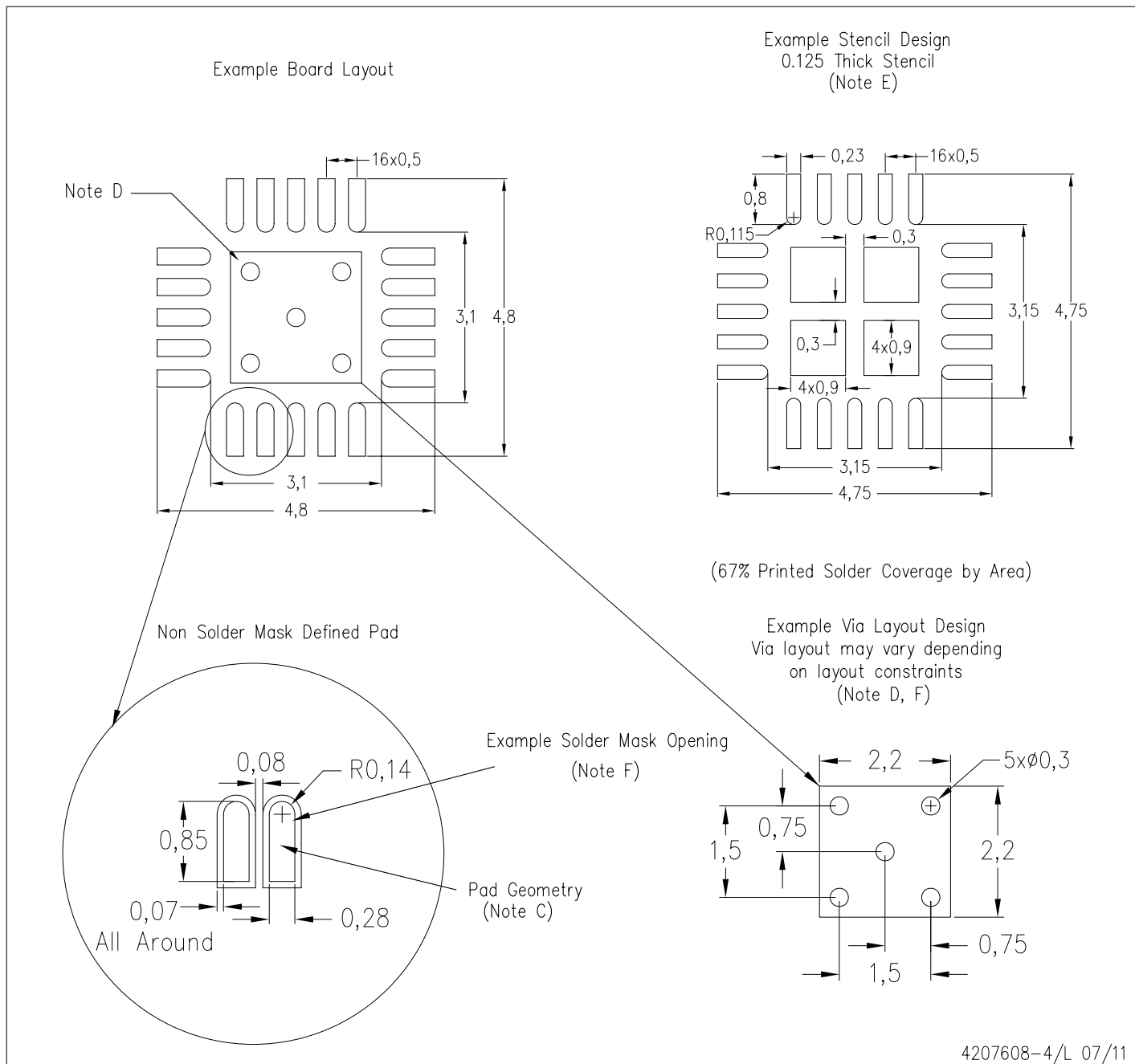

- NOTES:
- A. All linear dimensions are in millimeters.
  - B. This drawing is subject to change without notice.
  - C. Publication IPC-7351 is recommended for alternate designs.
  - D. This package is designed to be soldered to a thermal pad on the board. Refer to Application Note, Quad Flat-Pack Packages, Texas Instruments Literature No. SLUA271, and also the Product Data Sheets for specific thermal information, via requirements, and recommended board layout. These documents are available at [www.ti.com](http://www.ti.com) <<http://www.ti.com>>.
  - E. Laser cutting apertures with trapezoidal walls and also rounding corners will offer better paste release. Customers should contact their board assembly site for stencil design recommendations. Refer to IPC 7525 for stencil design considerations.
  - F. Customers should contact their board fabrication site for recommended solder mask tolerances and via tenting recommendations for vias placed in the thermal pad.

## 重要声明和免责声明

TI“按原样”提供技术和可靠性数据（包括数据表）、设计资源（包括参考设计）、应用或其他设计建议、网络工具、安全信息和其他资源，不保证没有瑕疵且不做任何明示或暗示的担保，包括但不限于对适销性、某特定用途方面的适用性或不侵犯任何第三方知识产权的暗示担保。

这些资源可供使用 TI 产品进行设计的熟练开发人员使用。您将自行承担以下全部责任：(1) 针对您的应用选择合适的 TI 产品，(2) 设计、验证并测试您的应用，(3) 确保您的应用满足相应标准以及任何其他功能安全、信息安全、监管或其他要求。

这些资源如有变更，恕不另行通知。TI 授权您仅可将这些资源用于研发本资源所述的 TI 产品的应用。严禁对这些资源进行其他复制或展示。您无权使用任何其他 TI 知识产权或任何第三方知识产权。您应全额赔偿因在这些资源的使用中对 TI 及其代表造成的任何索赔、损害、成本、损失和债务，TI 对此概不负责。

TI 提供的产品受 [TI 的销售条款](#) 或 [ti.com](#) 上其他适用条款/TI 产品随附的其他适用条款的约束。TI 提供这些资源并不会扩展或以其他方式更改 TI 针对 TI 产品发布的适用的担保或担保免责声明。

TI 反对并拒绝您可能提出的任何其他或不同的条款。

邮寄地址：Texas Instruments, Post Office Box 655303, Dallas, Texas 75265

Copyright © 2022，德州仪器 (TI) 公司