

SN74AHC595 8-Bit Shift Registers With 3-State Output Registers

1 Features

- Operating Range: 2-V to 5.5-V V_{CC}
- 8-Bit Serial-In, Parallel-Out Shift
- Latch-Up Performance Exceeds 100 mA Per JESD 78, Class II
- ESD Protection Exceeds JESD 22
 - 2000-V Human-Body Model (A114-A)
 - 200-V Machine Model (A115-A)
 - 1000-V Charged-Device Model (C101)

2 Applications

- Network Switches
- Power Infrastructures
- LED Displays
- Servers

3 Description

The SN74AHC595 device contains an 8-bit serial-in, parallel-out shift register that feeds an 8-bit D-type storage register. The storage register has parallel 3-state outputs. Separate clocks are provided for both the shift and storage registers. The shift register has a direct overriding clear (SRCLR) input, a serial (SER) input, and a serial output for cascading. When the output-enable (\overline{OE}) input is high, all outputs except QH' are in the high-impedance state.

Device Information

PART NUMBER	PACKAGE	BODY SIZE (NOM)
SN74AHC595N	PDIP (16)	19.31 mm x 6.35 mm
SN74AHC595D	SOIC (16)	9.90 mm x 3.90 mm
SN74AHC595DB	SSOP (16)	6.20 mm x 5.30 mm
SN74AHC595PW	TSSOP (16)	5.00 mm x 4.40 mm

(1) For all available packages, see the orderable addendum at the end of the data sheet.

Logic Diagram (Positive Logic)

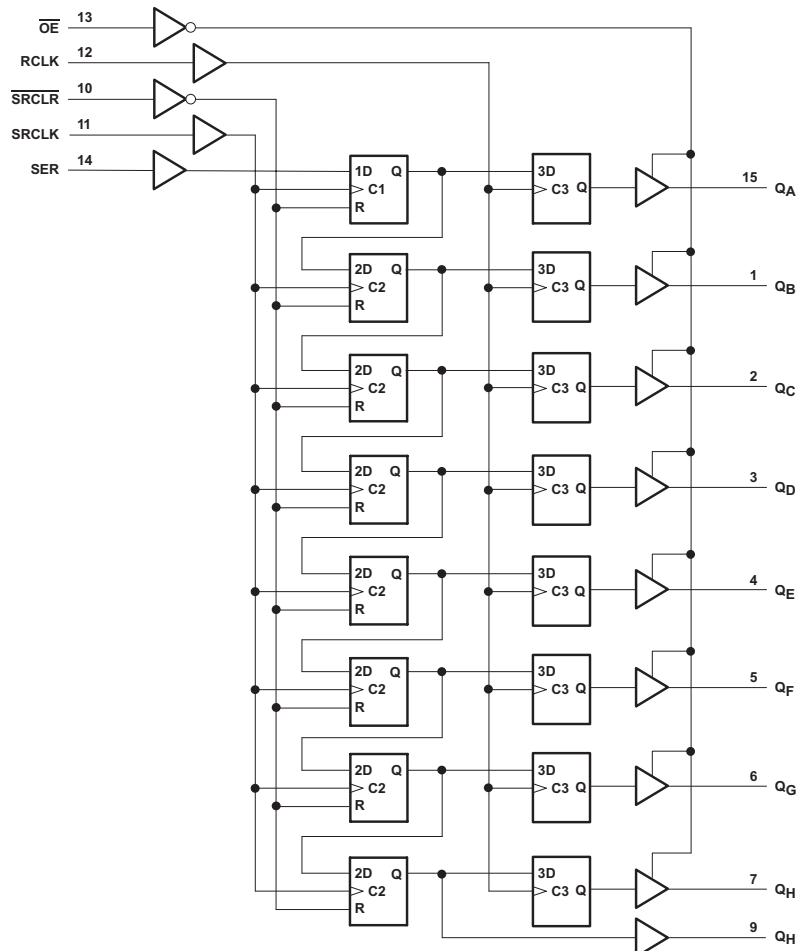

Table of Contents

1 Features	1	8.1 Overview	13
2 Applications	1	8.2 Functional Block Diagram	13
3 Description	1	8.3 Feature Description	14
4 Revision History	2	8.4 Device Functional Modes	14
5 Pin Configuration and Functions	3	9 Application and Implementation	15
6 Specifications	4	9.1 Application Information	15
6.1 Absolute Maximum Ratings	4	9.2 Typical Application	15
6.2 ESD Ratings	4	10 Power Supply Recommendations	17
6.3 Recommended Operating Conditions	4	11 Layout	17
6.4 Thermal Information	5	11.1 Layout Guidelines	17
6.5 Electrical Characteristics	5	11.2 Layout Example	17
6.6 Operating Characteristics	6	12 Device and Documentation Support	18
6.7 Timing Requirements: $V_{CC} = 3.3\text{ V} \pm 0.3\text{ V}$	6	12.1 Documentation Support	18
6.8 Timing Requirements: $V_{CC} = 5\text{ V} \pm 0.5\text{ V}$	7	12.2 Community Resources	18
6.9 Switching Characteristics: $V_{CC} = 3.3\text{ V} \pm 0.3\text{ V}$	7	12.3 Trademarks	18
6.10 Switching Characteristics: $V_{CC} = 5\text{ V} \pm 0.5\text{ V}$	9	12.4 Electrostatic Discharge Caution	18
6.11 Typical Characteristics	11	12.5 Glossary	18
7 Parameter Measurement Information	12	13 Mechanical, Packaging, and Orderable Information	18
8 Detailed Description	13		

4 Revision History

NOTE: Page numbers for previous revisions may differ from page numbers in the current version.

Changes from Revision J (July 2013) to Revision K	Page
• Deleted SN54AHC595 device from the data sheet	1
• Added <i>Device Information</i> table, <i>Pin Functions</i> table, <i>ESD Ratings</i> table, <i>Thermal Information</i> table, <i>Detailed Description</i> section, <i>Applications and Implementation</i> section, <i>Power Supply Recommendations</i> section, <i>Layout</i> section, <i>Device and Documentation Support</i> section, and <i>Mechanical, Packaging, and Orderable Information</i> section	1

Changes from Revision I (June 2004) to Revision J	Page
• Changed Updated document to new TI data sheet format.	1
• Extended operating temperature range to 125°C	4

5 Pin Configuration and Functions

D, DB, N, PW Packages
16-Pin SOIC, SSOP, PDIP, TSSOP
Top View

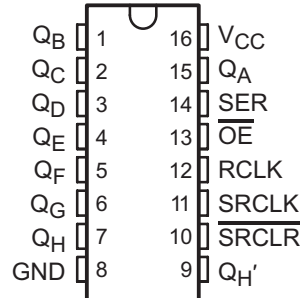

Pin Functions

PIN		I/O	DESCRIPTION
NAME	NO.		
GND	8	—	Ground Pin
\overline{OE}	13	I	Output Enable
Q _A	15	O	Q _A Output
Q _B	1	O	Q _B Output
Q _C	2	O	Q _C Output
Q _D	3	O	Q _D Output
Q _E	4	O	Q _E Output
Q _F	5	O	Q _F Output
Q _G	6	O	Q _G Output
Q _H	7	O	Q _H Output
Q _{H'}	9	O	Q _{H'} Output
RCLK	12	I	RCLK Input
SER	14	I	SER Input
SRCLK	11	I	SRCLK Input
\overline{SRCLR}	10	I	\overline{SRCLR} Input
V _{CC}	16	—	Power Pin

6 Specifications

6.1 Absolute Maximum Ratings

 over operating free-air temperature range (unless otherwise noted)⁽¹⁾

		MIN	MAX	UNIT
V _{CC}	Supply voltage	-0.5	7	V
V _I	Input voltage ⁽²⁾	-0.5	7	V
V _O	Output voltage ⁽²⁾	-0.5	V _{CC} + 0.5	V
I _{IK}	Input clamp current	(V _I < 0)	-20	mA
I _{OK}	Output clamp current	(V _O < 0 or V _O > V _{CC})	±20	mA
I _O	Continuous output current	(V _O = 0 to V _{CC})	±25	mA
Continuous current through V _{CC} or GND			±75	mA
T _J	Junction temperature		150	°C
T _{stg}	Storage temperature	-65	150	°C

- (1) Stresses beyond those listed under *Absolute Maximum Ratings* may cause permanent damage to the device. These are stress ratings only, and functional operation of the device at these or any other conditions beyond those indicated under *Recommended Operating Conditions* is not implied. Exposure to absolute-maximum-rated conditions for extended periods may affect device reliability.
- (2) The input and output voltage ratings may be exceeded if the input and output current ratings are observed.

6.2 ESD Ratings

		VALUE	UNIT
V _(ESD)	Electrostatic discharge	Human body model (HBM), per ANSI/ESDA/JEDEC JS-001 ⁽¹⁾	±2000
		Charged device model (CDM), per JEDEC specification JESD22-C101 ⁽²⁾	±1000

- (1) JEDEC document JEP155 states that 500-V HBM allows safe manufacturing with a standard ESD control process.
- (2) JEDEC document JEP157 states that 250-V CDM allows safe manufacturing with a standard ESD control process.

6.3 Recommended Operating Conditions

 over operating free-air temperature range (unless otherwise noted)⁽¹⁾

		MIN	NOM	MAX	UNIT
V _{CC}	Supply voltage	2		5.5	V
V _{IH}	High-level input voltage	V _{CC} = 2 V	1.5		V
		V _{CC} = 3 V	2.1		
		V _{CC} = 5.5 V	3.85		
V _{IL}	Low-level Input voltage	V _{CC} = 2 V		0.5	V
		V _{CC} = 3 V		0.9	
		V _{CC} = 5.5 V		1.65	
V _I	Input voltage	0		5.5	V
V _O	Output voltage	0		V _{CC}	V
I _{OH}	High-level output current	V _{CC} = 2 V		-50	μA
		V _{CC} = 3.3 V ± 0.3 V		-4	mA
		V _{CC} = 5 V ± 0.5 V		-8	
I _{OL}	Low-level output current	V _{CC} = 2 V		50	μA
		V _{CC} = 3.3 V ± 0.3 V		4	mA
		V _{CC} = 5 V ± 0.5 V		8	
Δt/Δv	Input transition rise or fall rate	V _{CC} = 3.3 V ± 0.3 V		100	ns/V
		V _{CC} = 5 V ± 0.5 V		20	
T _A	Operating free-air temperature	-40		125	°C

- (1) All unused inputs of the device must be held at V_{CC} or GND to ensure proper device operation. Refer to the TI application report, *Implications of Slow or Floating CMOS Inputs*, [SCBA004](#).

6.4 Thermal Information

THERMAL METRIC ⁽¹⁾		SN74AHC595				UNIT
		D (SOIC)	DB (SSOP)	N (PDIP)	PW (TSSOP)	
		16 PINS	16 PINS	16 PINS	16 PINS	
R _{θJA}	Junction-to-ambient thermal resistance	73	97.8	47.8	106.1	°C/W
R _{θJC(top)}	Junction-to-case (top) thermal resistance	—	48.1	35.1	40.8	°C/W
R _{θJB}	Junction-to-board thermal resistance	—	48.5	27.8	51.1	°C/W
ψ _{JT}	Junction-to-top characterization parameter	—	10.0	20.1	3.8	°C/W
ψ _{JB}	Junction-to-board characterization parameter	—	47.9	27.7	50.6	°C/W

(1) For more information about traditional and new thermal metrics, see the *Semiconductor and IC Package Thermal Metrics* application report, [SPRA953](#).

6.5 Electrical Characteristics

over operating free-air temperature range (unless otherwise noted) ⁽¹⁾

PARAMETER	TEST CONDITIONS		V _{CC}	MIN	TYP	MAX	UNIT
V _{OH}	I _{OH} = -50 μA	T _A = 25°C	2 V	1.9	2		V
		T _A = -40°C to 85°C		1.9			
		T _A = -40°C to 125°C Recommended		1.9			
	I _{OH} = -50 μA	T _A = 25°C	3 V	2.9	3		
		T _A = -40°C to 85°C		2.9			
		T _A = -40°C to 125°C Recommended		2.9			
	I _{OH} = -50 μA	T _A = 25°C	4.5 V	4.4	4.5		
		T _A = -40°C to 85°C		4.4			
		T _A = -40°C to 125°C Recommended		4.4			
	I _{OH} = -4 mA	T _A = 25°C	3 V	2.58			
		T _A = -40°C to 85°C		2.48			
		T _A = -40°C to 125°C Recommended		2.48			
I _{OH} = -8 mA	T _A = 25°C	4.5 V	3.94				
	T _A = -40°C to 85°C		3.8				
	T _A = -40°C to 125°C Recommended		3.8				
V _{OL}	I _{OL} = 50 μA	T _A = 25°C	2 V			0.1	V
		T _A = -40°C to 85°C				0.1	
		T _A = -40°C to 125°C Recommended				0.1	
	I _{OL} = 50 μA	T _A = 25°C	3 V			0.1	
		T _A = -40°C to 85°C				0.1	
		T _A = -40°C to 125°C Recommended				0.1	
	I _{OL} = 50 μA	T _A = 25°C	4.5 V			0.1	
		T _A = -40°C to 85°C				0.1	
		T _A = -40°C to 125°C Recommended				0.1	
	I _{OL} = 4 mA	T _A = 25°C	3 V			0.36	
		T _A = -40°C to 85°C				0.44	
		T _A = -40°C to 125°C Recommended				0.44	
I _{OL} = 8 mA	T _A = 25°C	4.5 V			0.36		
	T _A = -40°C to 85°C				0.44		
	T _A = -40°C to 125°C Recommended				0.44		
I _I	V _I = 5.5 V or GND	T _A = 25°C	0 V to 5.5 V			±0.1	μA
		T _A = -40°C to 85°C				±1	
		T _A = -40°C to 125°C Recommended				±1	
I _{OZ}	V _I = V _{CC} or GND, V _O = V _{CC} or GND, OE = V _{IH} or V _{IL} ,	Q _A - Q _H	5.5 V	T _A = 25°C		±0.25	μA
				T _A = -40°C to 85°C		±2.5	
				T _A = -40°C to 125°C Recommended		±2.5	

(1) On products compliant to MIL-PRF-38535, this parameter is not production tested at V_{CC} = 0 V.

Electrical Characteristics (continued)

 over operating free-air temperature range (unless otherwise noted) ⁽¹⁾

PARAMETER	TEST CONDITIONS		V _{CC}	MIN	TYP	MAX	UNIT
I _{CC}	V _I = V _{CC} or GND,	I _O = 0	5.5 V			T _A = 25°C	4
						T _A = –40°C to 85°C	40
						T _A = –40°C to 125°C Recommended	40
C _i	V _I = V _{CC} or GND	T _A = 25°C	5 V		3	10	pF
		T _A = –40°C TO 85°C				10	
C _O	V _O = V _{CC} or GND,	T _A = 25°C	5 V		5.5		pF

6.6 Operating Characteristics

 V_{CC} = 5 V, T_A = 25°C

PARAMETER	TEST CONDITIONS	TYP	UNIT
C _{pd}	Power dissipation capacitance No load, f = 1 MHz	25.2	pF

6.7 Timing Requirements: V_{CC} = 3.3 V ± 0.3 V

over recommended operating free-air temperature range (unless otherwise noted)

			MIN	MAX	UNIT
t _w	Pulse duration	SRCLK high or low	T _A = 25°C	5	ns
			T _A = –40°C to 85°C	5	
			T _A = –40°C to 125°C Recommended	6	
	RCLK high or low	T _A = 25°C	5		
		T _A = –40°C to 85°C	5		
		T _A = –40°C to 125°C Recommended	6		
	SRCLR low	T _A = 25°C	5		
		T _A = –40°C to 85°C	5		
		T _A = –40°C to 125°C Recommended	6.5		
t _{su}	Set-up time	SER before SRCLK↑	T _A = 25°C	3.5	
			T _A = –40°C to 85°C	3.5	
			T _A = –40°C to 125°C Recommended	4.5	
	SRCLK↑ before RCLK↑ ⁽¹⁾	T _A = 25°C	8		
		T _A = –40°C to 85°C	8.5		
		T _A = –40°C to 125°C Recommended	9.5		
	SRCLR low before RCLK↑	T _A = 25°C	8		
		T _A = –40°C to 85°C	9		
		T _A = –40°C to 125°C Recommended	10		
	SRCLR high (inactive) before SRCLK↑	T _A = 25°C	3		
		T _A = –40°C to 85°C	3		
		T _A = –40°C to 125°C Recommended	4		
t _h	Hold time	SER after SRCLK↑	T _A = 25°C	1.5	
			T _A = –40°C to 85°C	1.5	
			T _A = –40°C to 125°C Recommended	2.5	

(1) This set-up time allows the storage register to receive stable data from the shift register. The clocks can be tied together, in which case the shift register is one clock pulse ahead of the storage register.

6.8 Timing Requirements: $V_{CC} = 5 V \pm 0.5 V$

			MIN	NOM	MAX	UNIT
t_W	SRCLK high or low	$T_A = 25^\circ\text{C}$	5			ns
		$T_A = -40^\circ\text{C}$ to 85°C	5			
		$T_A = -40^\circ\text{C}$ to 125°C Recommended	6			
	RCLK high or low	$T_A = 25^\circ\text{C}$	5			
		$T_A = -40^\circ\text{C}$ to 85°C	5			
		$T_A = -40^\circ\text{C}$ to 125°C Recommended	6			
	$\overline{\text{SRCLR}}$ low	$T_A = 25^\circ\text{C}$	5			
		$T_A = -40^\circ\text{C}$ to 85°C	5			
		$T_A = -40^\circ\text{C}$ to 125°C Recommended	6.2			
t_{su}	SER before SRCLK \uparrow	$T_A = 25^\circ\text{C}$	3			ns
		$T_A = -40^\circ\text{C}$ to 85°C	3			
		$T_A = -40^\circ\text{C}$ to 125°C Recommended	4			
	SRCLK \uparrow before RCLK \uparrow ⁽¹⁾	$T_A = 25^\circ\text{C}$	5			
		$T_A = -40^\circ\text{C}$ to 85°C	5			
		$T_A = -40^\circ\text{C}$ to 125°C Recommended	6			
	$\overline{\text{SRCLR}}$ low before RCLK \uparrow	$T_A = 25^\circ\text{C}$	5			
		$T_A = -40^\circ\text{C}$ to 85°C	5			
		$T_A = -40^\circ\text{C}$ to 125°C Recommended	6			
	$\overline{\text{SRCLR}}$ high (inactive) before SRCLK \uparrow	$T_A = 25^\circ\text{C}$	2.5			
		$T_A = -40^\circ\text{C}$ to 85°C	2.5			
		$T_A = -40^\circ\text{C}$ to 125°C Recommended	3.5			
t_h	SER after SRCLK \uparrow	$T_A = 25^\circ\text{C}$	2			ns
		$T_A = -40^\circ\text{C}$ to 85°C	2			
		$T_A = -40^\circ\text{C}$ to 125°C Recommended	3			

(1) This set-up time allows the storage register to receive stable data from the shift register. The clocks can be tied together, in which case the shift register is one clock pulse ahead of the storage register.

6.9 Switching Characteristics: $V_{CC} = 3.3 V \pm 0.3 V$

over operating free-air temperature range (unless otherwise noted)

PARAMETER	FROM (INPUT)	TO (OUTPUT)	LOAD CAPACITANCE	TEST CONDITIONS	MIN	TYP	MAX	UNIT
f_{max}			$C_L = 15 \text{ pF}$	$T_A = 25^\circ\text{C}$	80 ⁽¹⁾	120 ⁽¹⁾		MHz
				$T_A = -40^\circ\text{C}$ to 85°C	70			
				$T_A = -40^\circ\text{C}$ to 125°C Recommended	60			
			$C_L = 50 \text{ pF}$	$T_A = 25^\circ\text{C}$	55	105		
				$T_A = -40^\circ\text{C}$ to 85°C	50			
				$T_A = -40^\circ\text{C}$ to 125°C Recommended	40			
t_{PLH}	RCLK	$Q_A - Q_H$	$C_L = 15 \text{ pF}$	$T_A = 25^\circ\text{C}$		6 ⁽¹⁾	11.9 ⁽¹⁾	ns
				$T_A = -40^\circ\text{C}$ to 85°C	1		13.5	
				$T_A = -40^\circ\text{C}$ to 125°C Recommended	1		14.9	
t_{PHL}	RCLK	$Q_A - Q_H$	$C_L = 15 \text{ pF}$	$T_A = 25^\circ\text{C}$		6 ⁽¹⁾	11.9 ⁽¹⁾	ns
				$T_A = -40^\circ\text{C}$ to 85°C	1		13.5	
				$T_A = -40^\circ\text{C}$ to 125°C Recommended	1		14.9	
t_{PLH}	SRCLK	Q_H	$C_L = 15 \text{ pF}$	$T_A = 25^\circ\text{C}$		6.6 ⁽¹⁾	13 ⁽¹⁾	ns
				$T_A = -40^\circ\text{C}$ to 85°C	1		15	
				$T_A = -40^\circ\text{C}$ to 125°C Recommended	1		16.4	
t_{PHL}	SRCLK	Q_H	$C_L = 15 \text{ pF}$	$T_A = 25^\circ\text{C}$		6.6 ⁽¹⁾	13 ⁽¹⁾	ns
				$T_A = -40^\circ\text{C}$ to 85°C	1		15	
				$T_A = -40^\circ\text{C}$ to 125°C Recommended	1		16.4	

(1) On products compliant to MIL-PRF-38535, this parameter is not production tested.

Switching Characteristics: $V_{CC} = 3.3 V \pm 0.3 V$ (continued)

over operating free-air temperature range (unless otherwise noted)

PARAMETER	FROM (INPUT)	TO (OUTPUT)	LOAD CAPACITANCE	TEST CONDITIONS	MIN	TYP	MAX	UNIT
t_{PHL}	\overline{SRCLR}	Q_H	$C_L = 15 \text{ pF}$	$T_A = 25^\circ\text{C}$		6.2 ⁽¹⁾	12.8 ⁽¹⁾	ns
				$T_A = -40^\circ\text{C to } 85^\circ\text{C}$	1		13.7	
				$T_A = -40^\circ\text{C to } 125^\circ\text{C Recommended}$	1		15	
t_{PZH}	\overline{OE}	$Q_A - Q_H$	$C_L = 15 \text{ pF}$	$T_A = 25^\circ\text{C}$		6 ⁽¹⁾	11.5 ⁽¹⁾	ns
				$T_A = -40^\circ\text{C to } 85^\circ\text{C}$	1		13.5	
				$T_A = -40^\circ\text{C to } 125^\circ\text{C Recommended}$	1		14.9	
t_{PZL}	\overline{OE}	$Q_A - Q_H$	$C_L = 15 \text{ pF}$	$T_A = 25^\circ\text{C}$		7.8 ⁽¹⁾	11.5 ⁽¹⁾	ns
				$T_A = -40^\circ\text{C to } 85^\circ\text{C}$	1		13.5	
				$T_A = -40^\circ\text{C to } 125^\circ\text{C Recommended}$	1		14.9	
t_{PLH}	RCLK	$Q_A - Q_H$	$C_L = 50 \text{ pF}$	$T_A = 25^\circ\text{C}$		7.9	15.4	ns
				$T_A = -40^\circ\text{C to } 85^\circ\text{C}$	1		17	
				$T_A = -40^\circ\text{C to } 125^\circ\text{C Recommended}$	1		18.6	
t_{PHL}	RCLK	$Q_A - Q_H$	$C_L = 50 \text{ pF}$	$T_A = 25^\circ\text{C}$		7.9	15.4	ns
				$T_A = -40^\circ\text{C to } 85^\circ\text{C}$	1		17	
				$T_A = -40^\circ\text{C to } 125^\circ\text{C Recommended}$	1		18.6	
t_{PLH}	SRCLK	Q_H	$C_L = 50 \text{ pF}$	$T_A = 25^\circ\text{C}$		9.2	16.5	ns
				$T_A = -40^\circ\text{C to } 85^\circ\text{C}$	1		18.5	
				$T_A = -40^\circ\text{C to } 125^\circ\text{C Recommended}$	1		20	
t_{PHL}	SRCLK	Q_H	$C_L = 50 \text{ pF}$	$T_A = 25^\circ\text{C}$		9.2	16.5	ns
				$T_A = -40^\circ\text{C to } 85^\circ\text{C}$	1		18.5	
				$T_A = -40^\circ\text{C to } 125^\circ\text{C Recommended}$	1		20	
t_{PHL}	\overline{SRCLR}	Q_H	$C_L = 50 \text{ pF}$	$T_A = 25^\circ\text{C}$		9	16.3	ns
				$T_A = -40^\circ\text{C to } 85^\circ\text{C}$	1		17.2	
				$T_A = -40^\circ\text{C to } 125^\circ\text{C Recommended}$	1		18.7	
t_{PZH}	\overline{OE}	$Q_A - Q_H$	$C_L = 50 \text{ pF}$	$T_A = 25^\circ\text{C}$		7.8	15	ns
				$T_A = -40^\circ\text{C to } 85^\circ\text{C}$	1		17	
				$T_A = -40^\circ\text{C to } 125^\circ\text{C Recommended}$	1		18.6	
t_{PZL}	\overline{OE}	$Q_A - Q_H$	$C_L = 50 \text{ pF}$	$T_A = 25^\circ\text{C}$		9.6	15	ns
				$T_A = -40^\circ\text{C to } 85^\circ\text{C}$	1		17	
				$T_A = -40^\circ\text{C to } 125^\circ\text{C Recommended}$	1		18.6	
t_{PHZ}	\overline{OE}	$Q_A - Q_H$	$C_L = 50 \text{ pF}$	$T_A = 25^\circ\text{C}$		8.1	15.7	ns
				$T_A = -40^\circ\text{C to } 85^\circ\text{C}$	1		16.2	
				$T_A = -40^\circ\text{C to } 125^\circ\text{C Recommended}$	1		17.4	
t_{PLZ}	\overline{OE}	$Q_A - Q_H$	$C_L = 50 \text{ pF}$	$T_A = 25^\circ\text{C}$		9.3	15.7	ns
				$T_A = -40^\circ\text{C to } 85^\circ\text{C}$	1		16.2	
				$T_A = -40^\circ\text{C to } 125^\circ\text{C Recommended}$	1		17.4	

6.10 Switching Characteristics: $V_{CC} = 5 V \pm 0.5 V$

over operating free-air temperature range (unless otherwise noted)

PARAMETER	FROM (INPUT)	TO (OUTPUT)	LOAD CAPACITANCE	TEST CONDITIONS	MIN	TYP	MAX	UNIT
f_{max}			$C_L = 15 \text{ pF}$	$T_A = 25^\circ\text{C}$	135 ⁽¹⁾	170 ⁽¹⁾		MHz
				$T_A = -40^\circ\text{C to } 85^\circ\text{C}$	115			
			$C_L = 50 \text{ pF}$	$T_A = 25^\circ\text{C}$	95	140		
				$T_A = -40^\circ\text{C to } 85^\circ\text{C}$	85			
t_{PLH}	RCLK	$Q_A - Q_H$	$C_L = 15 \text{ pF}$	$T_A = 25^\circ\text{C}$		4.3 ⁽¹⁾	7.4 ⁽¹⁾	ns
				$T_A = -40^\circ\text{C to } 85^\circ\text{C}$	1		8.5	
t_{PHL}	RCLK	$Q_A - Q_H$	$C_L = 15 \text{ pF}$	$T_A = 25^\circ\text{C}$		4.3 ⁽¹⁾	7.4 ⁽¹⁾	ns
				$T_A = -40^\circ\text{C to } 85^\circ\text{C}$	1		8.5	
t_{PLH}	SRCLK	Q_H	$C_L = 15 \text{ pF}$	$T_A = 25^\circ\text{C}$		4.5 ⁽¹⁾	8.2 ⁽¹⁾	ns
				$T_A = -40^\circ\text{C to } 85^\circ\text{C}$	1		9.4	
t_{PHL}	SRCLK	Q_H	$C_L = 15 \text{ pF}$	$T_A = 25^\circ\text{C}$		4.5 ⁽¹⁾	8.2 ⁽¹⁾	ns
				$T_A = -40^\circ\text{C to } 85^\circ\text{C}$	1		9.4	
t_{PHL}	$\overline{\text{SRCLR}}$	Q_H	$C_L = 15 \text{ pF}$	$T_A = 25^\circ\text{C}$		4.5 ⁽¹⁾	8 ⁽¹⁾	ns
				$T_A = -40^\circ\text{C to } 85^\circ\text{C}$	1		9.1	
t_{PZH}	$\overline{\text{OE}}$	$Q_A - Q_H$	$C_L = 15 \text{ pF}$	$T_A = 25^\circ\text{C}$		4.3 ⁽¹⁾	8.6 ⁽¹⁾	ns
				$T_A = -40^\circ\text{C to } 85^\circ\text{C}$	1		10	
t_{PZL}	$\overline{\text{OE}}$	$Q_A - Q_H$	$C_L = 15 \text{ pF}$	$T_A = 25^\circ\text{C}$		5.4 ⁽¹⁾	8.6 ⁽¹⁾	ns
				$T_A = -40^\circ\text{C to } 85^\circ\text{C}$	1		10	
t_{PLH}	RCLK	$Q_A - Q_H$	$C_L = 50 \text{ pF}$	$T_A = 25^\circ\text{C}$		5.6	9.4	ns
				$T_A = -40^\circ\text{C to } 85^\circ\text{C}$	1		10.5	
t_{PHL}	RCLK	$Q_A - Q_H$	$C_L = 50 \text{ pF}$	$T_A = 25^\circ\text{C}$		5.6	9.4	ns
				$T_A = -40^\circ\text{C to } 85^\circ\text{C}$	1		10.5	
t_{PLH}	SRCLK	Q_H	$C_L = 50 \text{ pF}$	$T_A = 25^\circ\text{C}$		6.4	10.2	ns
				$T_A = -40^\circ\text{C to } 85^\circ\text{C}$	1		11.4	
t_{PHL}	SRCLK	Q_H	$C_L = 50 \text{ pF}$	$T_A = 25^\circ\text{C}$		6.4	10.2	ns
				$T_A = -40^\circ\text{C to } 85^\circ\text{C}$	1		11.4	
t_{PHL}	$\overline{\text{SRCLR}}$	Q_H	$C_L = 50 \text{ pF}$	$T_A = 25^\circ\text{C}$		6.4	10	ns
				$T_A = -40^\circ\text{C to } 85^\circ\text{C}$	1		11.1	
t_{PZH}	$\overline{\text{OE}}$	$Q_A - Q_H$	$C_L = 50 \text{ pF}$	$T_A = 25^\circ\text{C}$		5.7	10.6	ns
				$T_A = -40^\circ\text{C to } 85^\circ\text{C}$	1		12	
t_{PZL}	$\overline{\text{OE}}$	$Q_A - Q_H$	$C_L = 50 \text{ pF}$	$T_A = 25^\circ\text{C}$		6.8	10.6	ns
				$T_A = -40^\circ\text{C to } 85^\circ\text{C}$	1		12	
t_{PHZ}	$\overline{\text{OE}}$	$Q_A - Q_H$	$C_L = 50 \text{ pF}$	$T_A = 25^\circ\text{C}$		3.5	10.3	ns
				$T_A = -40^\circ\text{C to } 85^\circ\text{C}$	1		11	
t_{PLZ}	$\overline{\text{OE}}$	$Q_A - Q_H$	$C_L = 50 \text{ pF}$	$T_A = 25^\circ\text{C}$		3.4	10.3	ns
				$T_A = -40^\circ\text{C to } 85^\circ\text{C}$	1		11	

(1) On products compliant to MIL-PRF-38535, this parameter is not production tested.

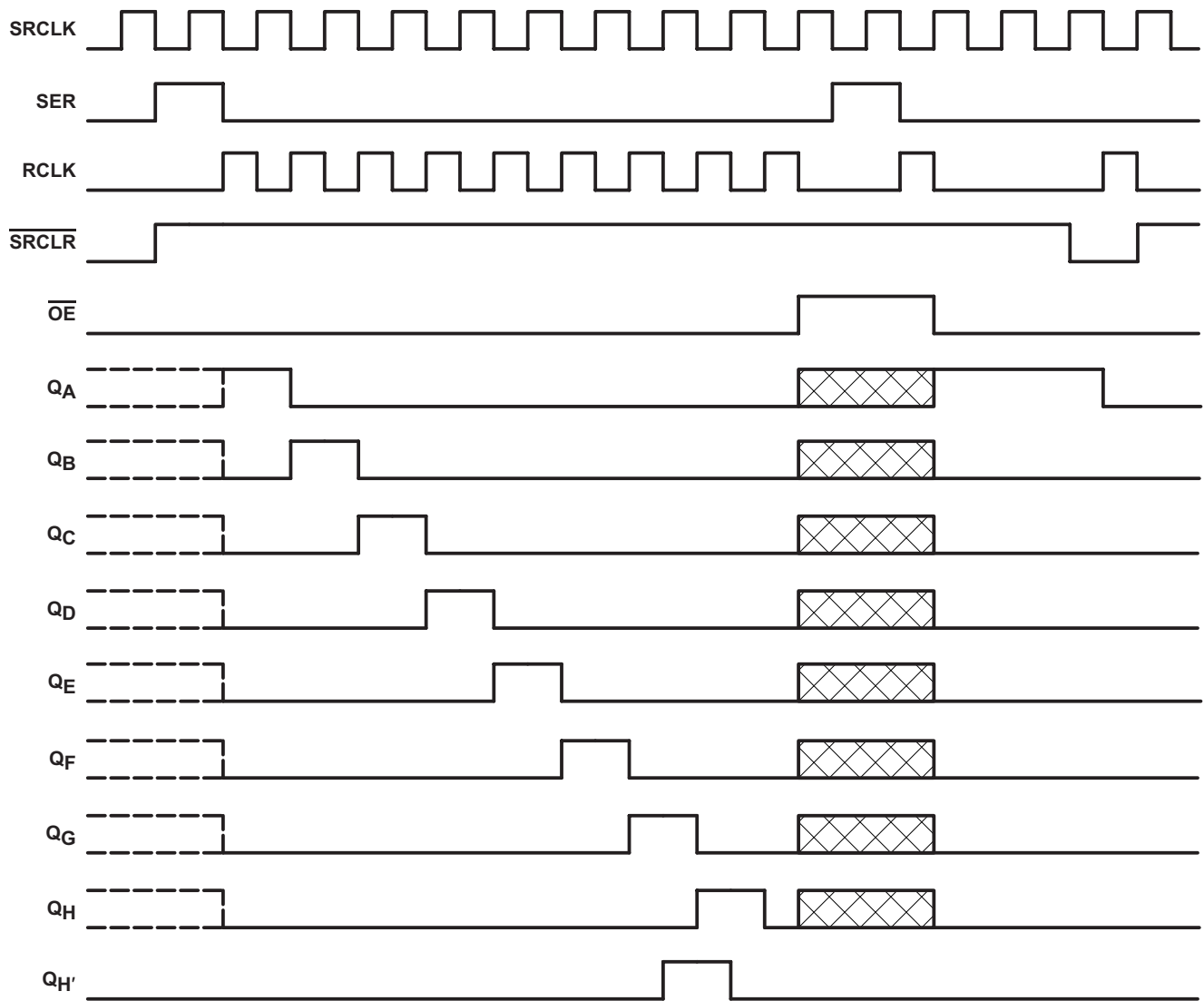

NOTE:  implies that the output is in 3-State mode.

Figure 1. Timing Diagram

6.11 Typical Characteristics

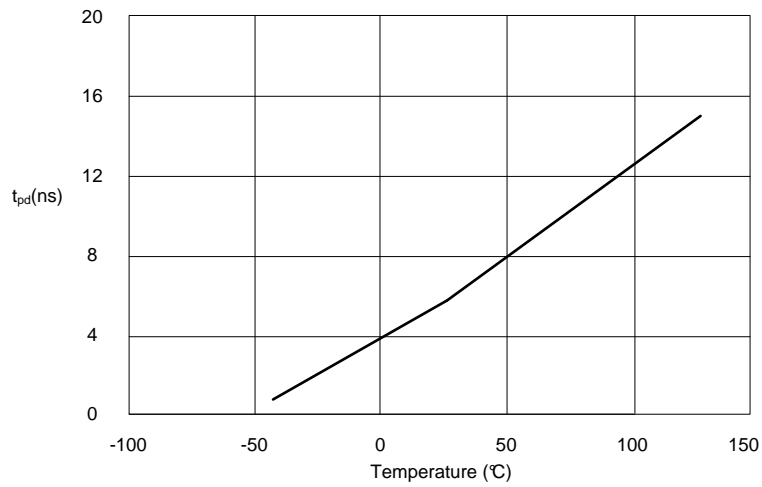

$V_{CC} = 3.3\text{ V}$

15-pF Load

Figure 2. SN74AHC595 RCLK to Q TPD vs Temperature

7 Parameter Measurement Information

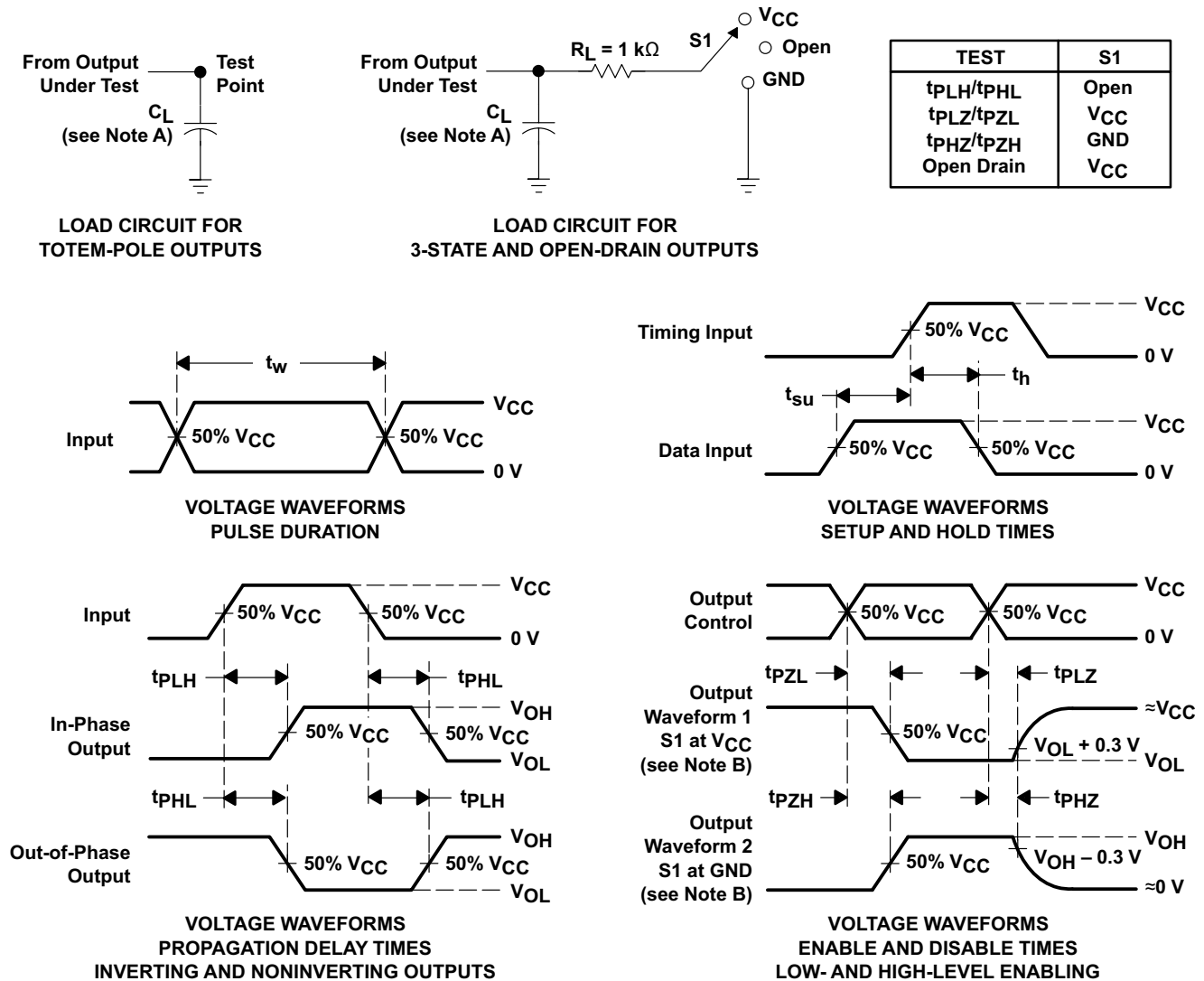

- C_L includes probe and jig capacitance.
- Waveform 1 is for an output with internal conditions such that the output is low except when disabled by the output control.
Waveform 2 is for an output with internal conditions such that the output is high except when disabled by the output control.
- All input pulses are supplied by generators having the following characteristics: $PRR \leq 1$ MHz, $Z_O = 50 \Omega$, $t_r \leq 3$ ns, $t_f \leq 3$ ns.
- The outputs are measured one at a time with one input transition per measurement.
- All parameters and waveforms are not applicable to all devices.

Figure 3. Load Circuit and Voltage Waveforms

8 Detailed Description

8.1 Overview

The SN74AHC595 device is part of the AHC family of logic devices intended for CMOS applications. The SN74HC595 device is an 8-bit shift register that feeds an 8-bit D-type storage register.

Both the shift-register clock (SRCLK) and storage-register clock (RCLK) are positive-edge triggered. If both clocks are connected together, the shift register is always one clock pulse ahead of the storage register.

8.2 Functional Block Diagram

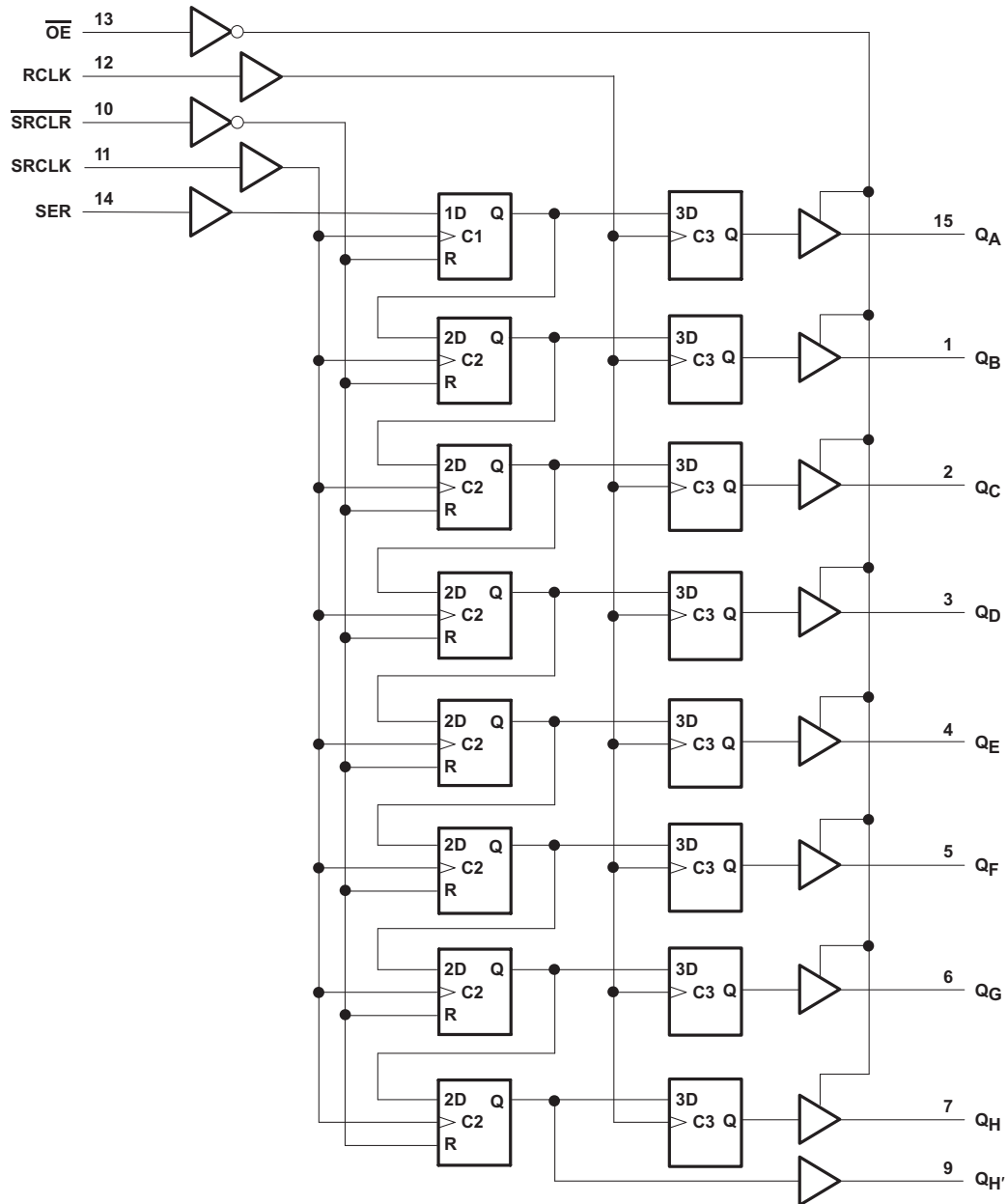

8.3 Feature Description

The SN74AHC595 device is an 8-bit serial-in, parallel-out shift registers that have a wide operating voltage range from 2 V to 5.5 V and a low current consumption of 40- μ A (max) I_{CC} .

8.4 Device Functional Modes

Table 1. Function Table

INPUTS					FUNCTION
SER	SRCLK	SRCLR	RCLK	OE	
X	X	X	X	H	Outputs Q_A – Q_H are disabled.
X	X	X	X	L	Outputs Q_A – Q_H are enabled.
X	X	L	X	X	Shift register is cleared.
L	↑	H	X	X	First stage of the shift register goes low. Other stages store the data of previous stage, respectively.
H	↑	H	X	X	First stage of the shift register goes high. Other stages store the data of previous stage, respectively.
X	X	X	↑	X	Shift-register data is stored into the storage register.

9 Application and Implementation

NOTE

Information in the following applications sections is not part of the TI component specification, and TI does not warrant its accuracy or completeness. TI's customers are responsible for determining suitability of components for their purposes. Customers should validate and test their design implementation to confirm system functionality.

9.1 Application Information

The SN74AHC595 device is a low-drive CMOS device that can be used for a multitude of bus-interface type applications where output ringing is a concern. The low drive and slow edge rates minimize overshoot and undershoot on the outputs. Figure 4 shows an application where eight LEDs are used to visualize the data bits contained within the shift register.

9.2 Typical Application

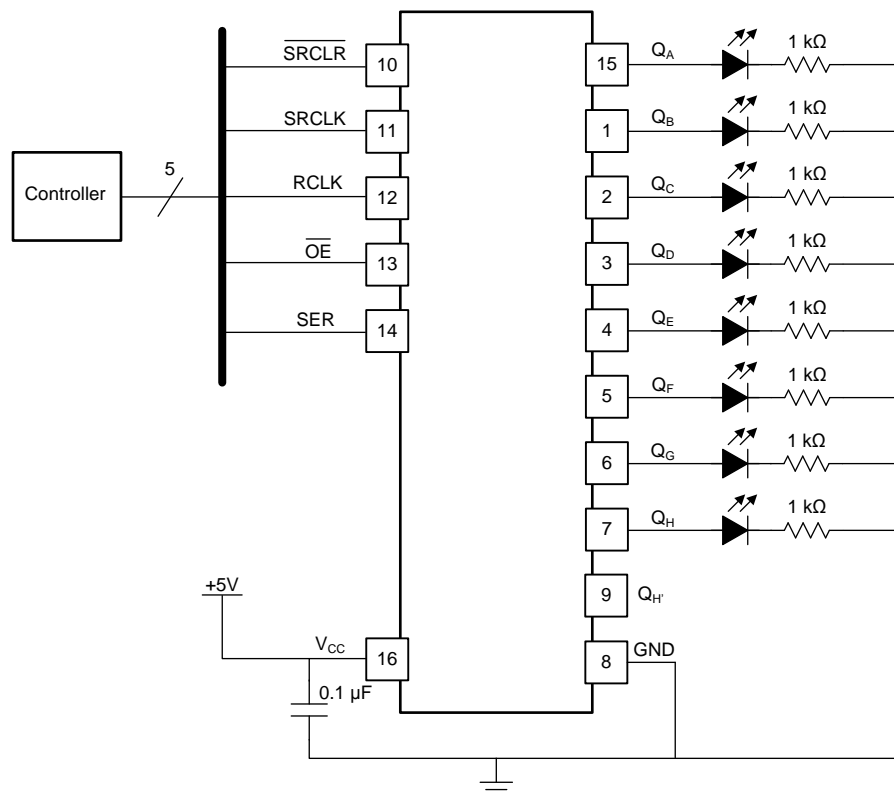

Figure 4. Shift Register Display of 8 bits

9.2.1 Design Requirements

This device uses CMOS technology and has balanced output drive. Care must be taken to avoid bus contention because it can drive currents that would exceed maximum limits. The high drive will also create fast edges into light loads, so routing and load conditions must be considered to prevent ringing.

9.2.2 Detailed Design Procedure

- Recommended input conditions:
 - Specified high and low levels. See (V_{IH} and V_{IL}) in the *Recommended Operating Conditions* table.
 - Specified high and low levels. See (V_{IH} and V_{IL}) in the *Recommended Operating Conditions* table.
 - Inputs are overvoltage tolerant allowing them to go as high as 6.0 V at any valid V_{CC}

Typical Application (continued)

- Recommend output conditions:
 - Load currents must not exceed 25 mA per output and 75 mA total for the part
 - Outputs must not be pulled above V_{CC}

9.2.3 Application Curve

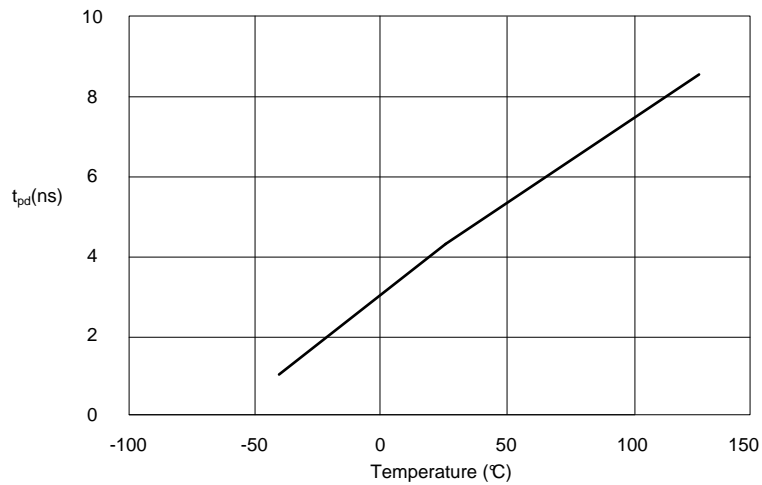
 $V_{CC} = 5\text{ V}$

15-pF Load

Figure 5. SN74AHC595 RCLK to Q TPD vs Temperature

10 Power Supply Recommendations

The power supply can be any voltage between the MIN and MAX supply-voltage rating located in the [Recommended Operating Conditions](#) table.

Each V_{CC} pin must have a good bypass capacitor to prevent power disturbance. For devices with a single supply, 0.1- μf capacitor is recommended; if there are multiple V_{CC} pins, then a 0.01- μf or a 0.022- μf capacitor is recommended for each power pin. It is acceptable to parallel multiple bypass capacitors to reject different frequencies of noise. A 0.1- μf and a 1- μf capacitor are commonly used in parallel. The bypass capacitor must be installed as close to the power pin as possible for best results.

11 Layout

11.1 Layout Guidelines

When using multiple-bit logic devices, inputs must never float.

In many cases, functions or parts of functions of digital logic devices are unused, for example, when only two inputs of a triple-input AND gate are used or only 3 of the 4 buffer gates are used. Such input pins must **not** be left unconnected because the undefined voltages at the outside connections results in undefined operational states. [Figure 6](#) specifies the rules that must be observed under all circumstances. All unused inputs of digital logic devices must be connected to a high or low bias to prevent them from floating. The logic level that must be applied to any particular unused input depends on the function of the device. Generally, these unused inputs will be tied to GND or V_{CC} , whichever makes more sense or is more convenient. It is generally acceptable to float outputs, unless the part is a transceiver. If the transceiver has an output-enable pin, it will disable the output section of the part when asserted. This will not disable the input section of the I/Os, so they cannot float when disabled.

11.2 Layout Example

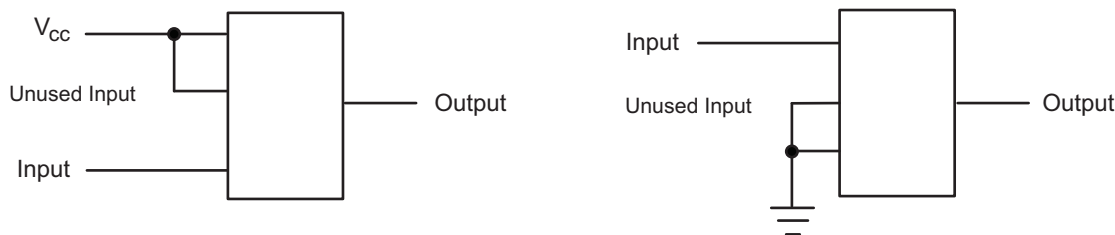

Figure 6. Layout Diagram

12 Device and Documentation Support

12.1 Documentation Support

12.1.1 Related Documentation

For related documentation, see the following:

Implications of Slow or Floating CMOS Inputs, [SCBA004](#)

12.2 Community Resources

The following links connect to TI community resources. Linked contents are provided "AS IS" by the respective contributors. They do not constitute TI specifications and do not necessarily reflect TI's views; see TI's [Terms of Use](#).

TI E2E™ Online Community *TI's Engineer-to-Engineer (E2E) Community*. Created to foster collaboration among engineers. At [e2e.ti.com](#), you can ask questions, share knowledge, explore ideas and help solve problems with fellow engineers.

Design Support *TI's Design Support* Quickly find helpful E2E forums along with design support tools and contact information for technical support.

12.3 Trademarks

E2E is a trademark of Texas Instruments.
All other trademarks are the property of their respective owners.

12.4 Electrostatic Discharge Caution



These devices have limited built-in ESD protection. The leads should be shorted together or the device placed in conductive foam during storage or handling to prevent electrostatic damage to the MOS gates.

12.5 Glossary

[SLYZ022](#) — *TI Glossary*.

This glossary lists and explains terms, acronyms, and definitions.

13 Mechanical, Packaging, and Orderable Information

The following pages include mechanical, packaging, and orderable information. This information is the most current data available for the designated devices. This data is subject to change without notice and revision of this document. For browser-based versions of this data sheet, refer to the left-hand navigation.

PACKAGING INFORMATION

Orderable Device	Status (1)	Package Type	Package Drawing	Pins	Package Qty	Eco Plan (2)	Lead finish/ Ball material (6)	MSL Peak Temp (3)	Op Temp (°C)	Device Marking (4/5)	Samples
SN74AHC595D	ACTIVE	SOIC	D	16	40	RoHS & Green	NIPDAU	Level-1-260C-UNLIM	-40 to 125	AHC595	Samples
SN74AHC595DBR	ACTIVE	SSOP	DB	16	2000	RoHS & Green	NIPDAU	Level-1-260C-UNLIM	-40 to 125	HA595	Samples
SN74AHC595DR	ACTIVE	SOIC	D	16	2500	RoHS & Green	NIPDAU	Level-1-260C-UNLIM	-40 to 125	AHC595	Samples
SN74AHC595DRE4	ACTIVE	SOIC	D	16	2500	RoHS & Green	NIPDAU	Level-1-260C-UNLIM	-40 to 125	AHC595	Samples
SN74AHC595N	ACTIVE	PDIP	N	16	25	RoHS & Green	NIPDAU	N / A for Pkg Type	-40 to 125	SN74AHC595N	Samples
SN74AHC595PW	ACTIVE	TSSOP	PW	16	90	RoHS & Green	NIPDAU	Level-1-260C-UNLIM	-40 to 125	HA595	Samples
SN74AHC595PWR	ACTIVE	TSSOP	PW	16	2000	RoHS & Green	NIPDAU SN	Level-1-260C-UNLIM	-40 to 125	HA595	Samples
SN74AHC595PWRG4	ACTIVE	TSSOP	PW	16	2000	RoHS & Green	NIPDAU	Level-1-260C-UNLIM	-40 to 125	HA595	Samples

(1) The marketing status values are defined as follows:

ACTIVE: Product device recommended for new designs.

LIFEBUY: TI has announced that the device will be discontinued, and a lifetime-buy period is in effect.

NRND: Not recommended for new designs. Device is in production to support existing customers, but TI does not recommend using this part in a new design.

PREVIEW: Device has been announced but is not in production. Samples may or may not be available.

OBSELETE: TI has discontinued the production of the device.

(2) **RoHS:** TI defines "RoHS" to mean semiconductor products that are compliant with the current EU RoHS requirements for all 10 RoHS substances, including the requirement that RoHS substance do not exceed 0.1% by weight in homogeneous materials. Where designed to be soldered at high temperatures, "RoHS" products are suitable for use in specified lead-free processes. TI may reference these types of products as "Pb-Free".

RoHS Exempt: TI defines "RoHS Exempt" to mean products that contain lead but are compliant with EU RoHS pursuant to a specific EU RoHS exemption.

Green: TI defines "Green" to mean the content of Chlorine (Cl) and Bromine (Br) based flame retardants meet JS709B low halogen requirements of <=1000ppm threshold. Antimony trioxide based flame retardants must also meet the <=1000ppm threshold requirement.

(3) MSL, Peak Temp. - The Moisture Sensitivity Level rating according to the JEDEC industry standard classifications, and peak solder temperature.

(4) There may be additional marking, which relates to the logo, the lot trace code information, or the environmental category on the device.

(5) Multiple Device Markings will be inside parentheses. Only one Device Marking contained in parentheses and separated by a "~" will appear on a device. If a line is indented then it is a continuation of the previous line and the two combined represent the entire Device Marking for that device.

⁽⁶⁾ Lead finish/Ball material - Orderable Devices may have multiple material finish options. Finish options are separated by a vertical ruled line. Lead finish/Ball material values may wrap to two lines if the finish value exceeds the maximum column width.

Important Information and Disclaimer:The information provided on this page represents TI's knowledge and belief as of the date that it is provided. TI bases its knowledge and belief on information provided by third parties, and makes no representation or warranty as to the accuracy of such information. Efforts are underway to better integrate information from third parties. TI has taken and continues to take reasonable steps to provide representative and accurate information but may not have conducted destructive testing or chemical analysis on incoming materials and chemicals. TI and TI suppliers consider certain information to be proprietary, and thus CAS numbers and other limited information may not be available for release.

In no event shall TI's liability arising out of such information exceed the total purchase price of the TI part(s) at issue in this document sold by TI to Customer on an annual basis.

OTHER QUALIFIED VERSIONS OF SN74AHC595 :

- Automotive : [SN74AHC595-Q1](#)

NOTE: Qualified Version Definitions:

- Automotive - Q100 devices qualified for high-reliability automotive applications targeting zero defects

TAPE AND REEL INFORMATION

QUADRANT ASSIGNMENTS FOR PIN 1 ORIENTATION IN TAPE



*All dimensions are nominal

Device	Package Type	Package Drawing	Pins	SPQ	Reel Diameter (mm)	Reel Width W1 (mm)	A0 (mm)	B0 (mm)	K0 (mm)	P1 (mm)	W (mm)	Pin1 Quadrant
SN74AHC595DBR	SSOP	DB	16	2000	330.0	16.4	8.35	6.6	2.4	12.0	16.0	Q1
SN74AHC595DR	SOIC	D	16	2500	330.0	16.4	6.5	10.3	2.1	8.0	16.0	Q1
SN74AHC595DR	SOIC	D	16	2500	330.0	16.4	6.5	10.3	2.1	8.0	16.0	Q1
SN74AHC595PWR	TSSOP	PW	16	2000	330.0	12.4	6.9	5.6	1.6	8.0	12.0	Q1
SN74AHC595PWR	TSSOP	PW	16	2000	330.0	12.4	6.9	5.6	1.6	8.0	12.0	Q1
SN74AHC595PW RG4	TSSOP	PW	16	2000	330.0	12.4	6.9	5.6	1.6	8.0	12.0	Q1

TAPE AND REEL BOX DIMENSIONS

*All dimensions are nominal

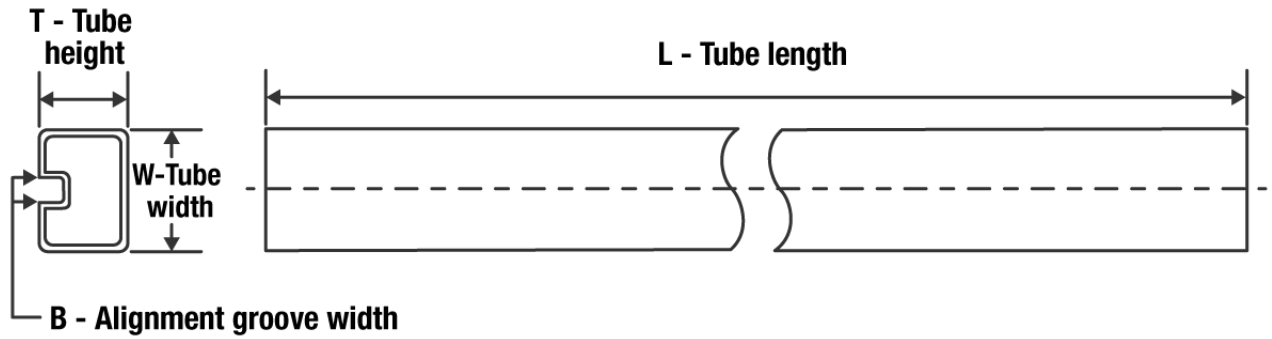
Device	Package Type	Package Drawing	Pins	SPQ	Length (mm)	Width (mm)	Height (mm)
SN74AHC595DBR	SSOP	DB	16	2000	853.0	449.0	35.0
SN74AHC595DR	SOIC	D	16	2500	340.5	336.1	32.0
SN74AHC595DR	SOIC	D	16	2500	853.0	449.0	35.0
SN74AHC595PWR	TSSOP	PW	16	2000	853.0	449.0	35.0
SN74AHC595PWR	TSSOP	PW	16	2000	364.0	364.0	27.0
SN74AHC595PW RG4	TSSOP	PW	16	2000	367.0	367.0	35.0

TUBE

*All dimensions are nominal

Device	Package Name	Package Type	Pins	SPQ	L (mm)	W (mm)	T (μm)	B (mm)
SN74AHC595D	D	SOIC	16	40	507	8	3940	4.32
SN74AHC595D	D	SOIC	16	40	506.6	8	3940	4.32
SN74AHC595N	N	PDIP	16	25	506	13.97	11230	4.32
SN74AHC595N	N	PDIP	16	25	506	13.97	11230	4.32
SN74AHC595PW	PW	TSSOP	16	90	530	10.2	3600	3.5

D (R-PDSO-G16)

PLASTIC SMALL OUTLINE

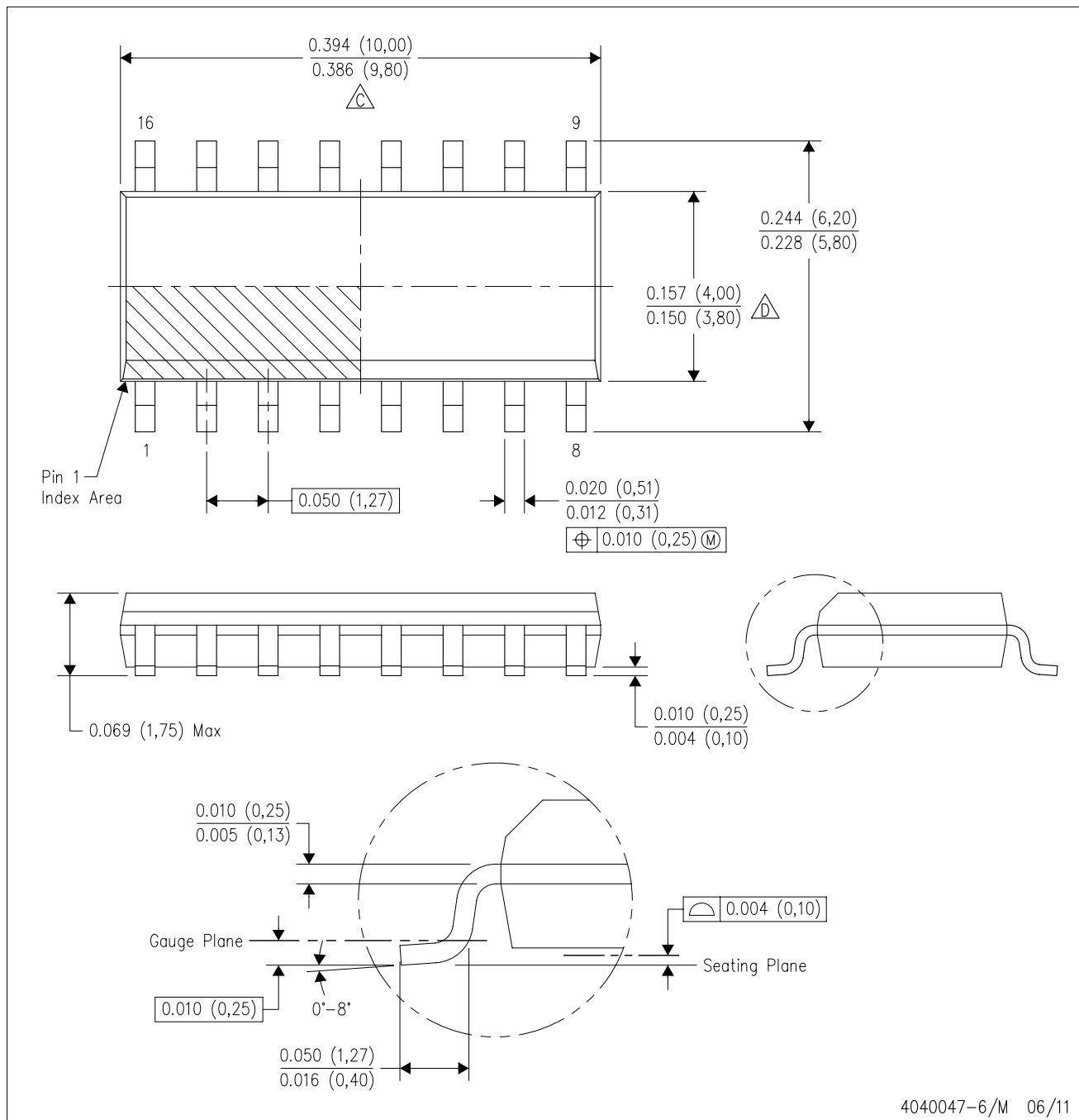

- NOTES:
- A. All linear dimensions are in inches (millimeters).
 - B. This drawing is subject to change without notice.
 - Body length does not include mold flash, protrusions, or gate burrs. Mold flash, protrusions, or gate burrs shall not exceed 0.006 (0,15) each side.
 - Body width does not include interlead flash. Interlead flash shall not exceed 0.017 (0,43) each side.
 - E. Reference JEDEC MS-012 variation AC.

D (R-PDSO-G16)

PLASTIC SMALL OUTLINE



- NOTES:
- All linear dimensions are in millimeters.
 - This drawing is subject to change without notice.
 - Publication IPC-7351 is recommended for alternate designs.
 - Laser cutting apertures with trapezoidal walls and also rounding corners will offer better paste release. Customers should contact their board assembly site for stencil design recommendations. Refer to IPC-7525 for other stencil recommendations.
 - Customers should contact their board fabrication site for solder mask tolerances between and around signal pads.



4220204/A 02/2017

NOTES:

1. All linear dimensions are in millimeters. Any dimensions in parenthesis are for reference only. Dimensioning and tolerancing per ASME Y14.5M.
2. This drawing is subject to change without notice.
3. This dimension does not include mold flash, protrusions, or gate burrs. Mold flash, protrusions, or gate burrs shall not exceed 0.15 mm per side.
4. This dimension does not include interlead flash. Interlead flash shall not exceed 0.25 mm per side.
5. Reference JEDEC registration MO-153.

EXAMPLE BOARD LAYOUT

PW0016A

TSSOP - 1.2 mm max height

SMALL OUTLINE PACKAGE



LAND PATTERN EXAMPLE
EXPOSED METAL SHOWN
SCALE: 10X



SOLDER MASK DETAILS

4220204/A 02/2017

NOTES: (continued)

- 6. Publication IPC-7351 may have alternate designs.
- 7. Solder mask tolerances between and around signal pads can vary based on board fabrication site.

EXAMPLE STENCIL DESIGN

PW0016A

TSSOP - 1.2 mm max height

SMALL OUTLINE PACKAGE



SOLDER PASTE EXAMPLE
BASED ON 0.125 mm THICK STENCIL
SCALE: 10X

4220204/A 02/2017

NOTES: (continued)

8. Laser cutting apertures with trapezoidal walls and rounded corners may offer better paste release. IPC-7525 may have alternate design recommendations.
9. Board assembly site may have different recommendations for stencil design.

DB (R-PDSO-G**)

PLASTIC SMALL-OUTLINE

28 PINS SHOWN



- NOTES: A. All linear dimensions are in millimeters.
 B. This drawing is subject to change without notice.
 C. Body dimensions do not include mold flash or protrusion not to exceed 0,15.
 D. Falls within JEDEC MO-150

N (R-PDIP-T**)

PLASTIC DUAL-IN-LINE PACKAGE

16 PINS SHOWN



- NOTES:
- A. All linear dimensions are in inches (millimeters).
 - B. This drawing is subject to change without notice.
 - Falls within JEDEC MS-001, except 18 and 20 pin minimum body length (Dim A).
 - The 20 pin end lead shoulder width is a vendor option, either half or full width.

IMPORTANT NOTICE AND DISCLAIMER

TI PROVIDES TECHNICAL AND RELIABILITY DATA (INCLUDING DATA SHEETS), DESIGN RESOURCES (INCLUDING REFERENCE DESIGNS), APPLICATION OR OTHER DESIGN ADVICE, WEB TOOLS, SAFETY INFORMATION, AND OTHER RESOURCES "AS IS" AND WITH ALL FAULTS, AND DISCLAIMS ALL WARRANTIES, EXPRESS AND IMPLIED, INCLUDING WITHOUT LIMITATION ANY IMPLIED WARRANTIES OF MERCHANTABILITY, FITNESS FOR A PARTICULAR PURPOSE OR NON-INFRINGEMENT OF THIRD PARTY INTELLECTUAL PROPERTY RIGHTS.

These resources are intended for skilled developers designing with TI products. You are solely responsible for (1) selecting the appropriate TI products for your application, (2) designing, validating and testing your application, and (3) ensuring your application meets applicable standards, and any other safety, security, regulatory or other requirements.

These resources are subject to change without notice. TI grants you permission to use these resources only for development of an application that uses the TI products described in the resource. Other reproduction and display of these resources is prohibited. No license is granted to any other TI intellectual property right or to any third party intellectual property right. TI disclaims responsibility for, and you will fully indemnify TI and its representatives against, any claims, damages, costs, losses, and liabilities arising out of your use of these resources.

TI's products are provided subject to [TI's Terms of Sale](#) or other applicable terms available either on ti.com or provided in conjunction with such TI products. TI's provision of these resources does not expand or otherwise alter TI's applicable warranties or warranty disclaimers for TI products.

TI objects to and rejects any additional or different terms you may have proposed.

Mailing Address: Texas Instruments, Post Office Box 655303, Dallas, Texas 75265
Copyright © 2022, Texas Instruments Incorporated