

## ISO71xxCC 4242V<sub>PK</sub> 小封装低功耗三通道和四通道数字隔离器

### 1 特性

- 最大信号传输速率：50Mbps（5V 电源）
- 具有集成噪声滤波器的稳健耐用设计
- 缺省输出低选项（后缀 F）
- 低功耗，每通道 I<sub>CC</sub> 典型值（3.3V 电源）：
  - ISO7131：1Mbps 时为 1.5mA，25Mbps 时为 2.6mA
  - ISO7140：1Mbps 时为 1mA，25Mbps 时为 2.3mA
  - ISO7141：1Mbps 时为 1.3mA，25Mbps 时为 2.6mA
- 低传播延迟：典型值 23ns（3.3V 电源）
- 宽温度范围：-40°C 至 125°C
- 50kV/μs 瞬态抗扰度，典型值
- 采用 SiO<sub>2</sub> 隔离格栅，使用寿命长
- 可由 2.7V、3.3V 和 5V 电源及逻辑电平供电
- 小型四分之一尺寸小外形封装 (QSOP)-16 封装
- 安全及管理批准
  - 符合 UL 1577 的长达 1 分钟的 2500V<sub>RMS</sub> 隔离
  - 符合 DIN V VDE V 0884-10 (VDE V 0884-10):2006-12 的 4242V<sub>PK</sub> 隔离，566V<sub>PK</sub> 工作电压
  - CSA 组件接受通知 5A，IEC 60950-1 和 IEC 61010-1 终端设备标准
  - 符合 GB 4943.1-2011 的 CQC 认证

### 2 应用范围

- 通用隔离
  - 工业现场总线 (Fieldbus)
    - Profibus 现场总线
    - Modbus™
    - DeviceNet 数据总线
  - RS-232, RS-485
  - 串行外设接口

### 3 说明

ISO7131、ISO7140 和 ISO7141 器件提供符合 UL 标准的长达 1 分钟的 2500 V<sub>RMS</sub> 电流隔离，以及符合 VDE 标准的 4242 V<sub>PK</sub>。ISO7131 有三个通道，其中两个为正向通道，一个为反向通道。ISO7140 和 ISO7141 均为四通道隔离器；ISO7140 有四个正向通道，而 ISO7141 有三个正向通道和一个反向通道。这些器件在由 5V 电源和 3.3V/2.7V 电源供电时，分别可提供 50Mbps 和 40Mbps 的最大数据传输速率，并且输入上带有集成滤波器，适用于易受噪声干扰的应用。后缀 F 表示缺省输出状态为低电平；否则，缺省输出状态为高电平（请见表 3）。

每个隔离通道的逻辑输入和输出缓冲器均由二氧化硅 (SiO<sub>2</sub>) 绝缘格栅分离开来。与隔离式电源一起使用时，这些器件可防止数据总线或者其它电路上的噪声电流进入本地接地并且干扰或损坏敏感电路。这些器件具有晶体管晶体管逻辑电路 (TTL) 输入阈值，并且可由 2.7V、3.3V 和 5V 电压供电运行。通过 2.7V 或 3.3V 电源供电时，所有输入均可耐受 5V 电压。

器件信息<sup>(1)</sup>

器件型号	封装	封装尺寸 (标称值)
ISO7131CC	SSOP (16)	4.90mm × 3.90mm
ISO7140CC		
ISO7140FCC		
ISO7141CC		
ISO7141FCC		

(1) 如需了解所有可用封装，请见数据表末尾的可订购产品附录。

简化电路原理图

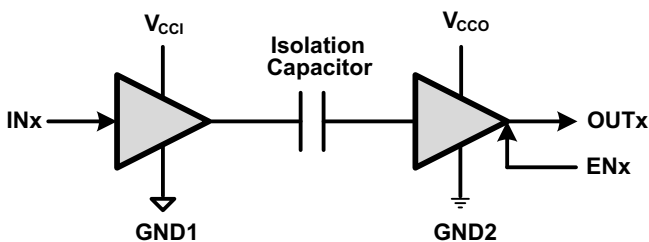

## 目录

<b>1</b>	特性 .....	<b>1</b>	6.14	Supply Current: $V_{CC1}$ and $V_{CC2}$ at 2.7 V .....	<b>11</b>
<b>2</b>	应用范围 .....	<b>1</b>	6.15	Typical Characteristics .....	<b>12</b>
<b>3</b>	说明 .....	<b>1</b>	<b>7</b>	<b>Parameter Measurement Information</b> .....	<b>14</b>
<b>4</b>	修订历史记录 .....	<b>2</b>	<b>8</b>	<b>Detailed Description</b> .....	<b>16</b>
<b>5</b>	<b>Pin Configuration and Functions</b> .....	<b>4</b>	8.1	Overview .....	<b>16</b>
<b>6</b>	<b>Specifications</b> .....	<b>5</b>	8.2	Functional Block Diagram .....	<b>16</b>
6.1	Absolute Maximum Ratings .....	<b>5</b>	8.3	Feature Description .....	<b>17</b>
6.2	ESD Ratings .....	<b>5</b>	8.4	Device Functional Modes .....	<b>19</b>
6.3	Recommended Operating Conditions .....	<b>5</b>	<b>9</b>	<b>Application and Implementation</b> .....	<b>21</b>
6.4	Thermal Information .....	<b>6</b>	9.1	Application Information .....	<b>21</b>
6.5	Power Dissipation Ratings .....	<b>6</b>	9.2	Typical Applications .....	<b>21</b>
6.6	Electrical Characteristics: $V_{CC1}$ and $V_{CC2}$ at 5 V $\pm 10\%$ .....	<b>6</b>	<b>10</b>	<b>Power Supply Recommendations</b> .....	<b>25</b>
6.7	Electrical Characteristics: $V_{CC1}$ and $V_{CC2}$ at 3.3 V $\pm 10\%$ .....	<b>6</b>	<b>11</b>	<b>Layout</b> .....	<b>25</b>
6.8	Electrical Characteristics: $V_{CC1}$ and $V_{CC2}$ at 2.7 V ...	<b>7</b>	11.1	Layout Guidelines .....	<b>25</b>
6.9	Switching Characteristics: $V_{CC1}$ and $V_{CC2}$ at 5 V $\pm 10\%$ .....	<b>7</b>	11.2	Layout Example .....	<b>25</b>
6.10	Switching Characteristics: $V_{CC1}$ and $V_{CC2}$ at 3.3 V $\pm 10\%$ .....	<b>8</b>	<b>12</b>	<b>器件和文档支持</b> .....	<b>26</b>
6.11	Switching Characteristics: $V_{CC1}$ and $V_{CC2}$ at 2.7 V ..	<b>8</b>	12.1	文档支持 .....	<b>26</b>
6.12	Supply Current: $V_{CC1}$ and $V_{CC2}$ at 5 V $\pm 10\%$ .....	<b>9</b>	12.2	相关链接 .....	<b>26</b>
6.13	Supply Current: $V_{CC1}$ and $V_{CC2}$ at 3.3 V $\pm 10\%$ ....	<b>10</b>	12.3	商标 .....	<b>26</b>
			12.4	静电放电警告 .....	<b>26</b>
			12.5	术语表 .....	<b>26</b>
			<b>13</b>	<b>机械封装和可订购信息</b> .....	<b>26</b>

## 4 修订历史记录

NOTE: Page numbers for previous revisions may differ from page numbers in the current version.

Changes from Revision E (September 2013) to Revision F	Page
• 已添加 引脚配置和功能部分, ESD 额定表, 特性描述部分, 器件功能模式, 应用和实施部分, 电源相关建议部分, 布局部分, 器件和文档支持部分以及机械、封装和可订购信息部分 .....	<b>1</b>
• VDE 标准更改为 DIN V VDE V 0884-10 (VDE V 0884-10):2006-12 .....	<b>1</b>

Changes from Revision D (August 2013) to Revision E	Page
• 将符合 UL 1577 的长达 1 分钟的 2500V <sub>RMS</sub> 隔离从 (审批正在审理中) 更改为 (已通过审批) .....	<b>1</b>
• Added note1 to the AVAILABLE OPTIONS table .....	<b>17</b>
• Changed 图 15 .....	<b>18</b>
• Changed From: Basic Insulation To: Basic Insulation, Altitude $\leq$ 5000m, Tropical Climate, 250 VRMS maximum working voltage in the Regulatory Information table .....	<b>19</b>
• Changed File number: E181974 (approval pending) To: File number: E181974 in the Regulatory Information table .....	<b>19</b>
• Changed the title of 图 21, 图 22, and 图 23 to include "PRBS 2 <sup>16</sup> - 1" .....	<b>23</b>

Changes from Revision C (July 2013) to Revision D	Page
• 添加了安全列表项“GB 4943.1-2011 和 GB 8898:2011 CQC 认证 (审批正在审理中)” .....	<b>1</b>
• Added 图 2 .....	<b>12</b>
• Deleted "Product Preview" From the AVAILABLE OPTIONS table .....	<b>17</b>
• Changed the REGULATORY INFORMATION, added column for CQC .....	<b>19</b>

<b>Changes from Revision B (June 2013) to Revision C</b>	<b>Page</b>
• 将特性从: ISO7140: 1Mbps 时待定 (TBD), 25Mbps 时 TBD 改为: ISO7140: 1Mbps 时为 1mA, 25Mbps 时为 2.3mA	1
• 在说明中添加了文本: “当由一个 2.7V 或者 3.3V 电源供电时, 所有输入均可耐受 5V 电压。”	1
• 删除了产品状态表	1
• 更改了安全和管理批准	1
• Changed the ABSOLUTE MAXIMUM RATINGS table	5
• Changed the SWITCHING CHARACTERISTICS table, Input glitch rejection time.	7
• Changed the SWITCHING CHARACTERISTICS table, Input glitch rejection time.	8
• Changed the SWITCHING CHARACTERISTICS table, Input glitch rejection time.	8
• Changed ISO7140 in the SUPPLY CURRENT table From: TBD To: values	9
• Changed ISO7140 in the SUPPLY CURRENT table From: TBD To: values	10
• Changed ISO7140 in the SUPPLY CURRENT table From: TBD To: values	11
• Changed 图 1 X-axis scale	12
• Changed the AVAILABLE OPTIONS table	17

<b>Changes from Revision A (June 2013) to Revision B</b>	<b>Page</b>
• 将器件 ISO7141CC 从: 产品预览改为: 在产品状态表中发布	1

<b>Changes from Original (April 2013) to Revision A</b>	<b>Page</b>
• 更改了简化电路原理图, 添加了接地符号	1
• Changed the SWITCHING CHARACTERISTICS table, Input glitch rejection time. Values by device.	7
• Changed the SWITCHING CHARACTERISTICS table, Input glitch rejection time. Values by device.	8
• Changed the SWITCHING CHARACTERISTICS table, Input glitch rejection time. Values by device.	8
• Added 图 3	12

## 5 Pin Configuration and Functions

**16-Pin  
SSOP Package  
Top View**

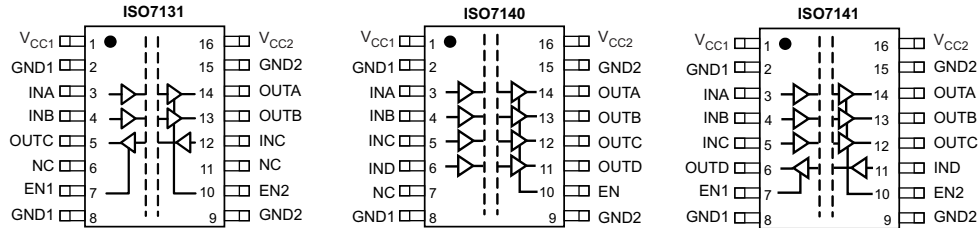

**Pin Functions**

NAME	PIN			I/O	DESCRIPTION
	ISO7131	ISO7140	ISO7141		
EN	—	10	—	I	Output enable. All output pins are enabled when EN is high or disconnected and disabled when EN is low.
EN1	7	—	7	I	Output enable 1. Output pins on side-1 are enabled when EN1 is high or disconnected and disabled when EN1 is low.
EN2	10	—	10	I	Output enable 2. Output pins on side-2 are enabled when EN2 is high or disconnected and disabled when EN2 is low.
GND1	2,8	2,8	2,8	—	Ground connection for $V_{CC1}$
GND2	9,15	9,15	9,15	—	Ground connection for $V_{CC2}$
INA	3	3	3	I	Input, channel A
INB	4	4	4	I	Input, channel B
INC	12	5	5	I	Input, channel C
IND	—	6	11	I	Input, channel D
NC	6,11	7	—	—	No Connect pins are floating with no internal connection
OUTA	14	14	14	O	Output, channel A
OUTB	13	13	13	O	Output, channel B
OUTC	5	12	12	O	Output, channel C
OUTD	—	11	6	O	Output, channel D
$V_{CC1}$	1	1	1	—	Power supply, $V_{CC1}$
$V_{CC2}$	16	16	16	—	Power supply, $V_{CC2}$

## 6 Specifications

### 6.1 Absolute Maximum Ratings<sup>(1)</sup>

		MIN	MAX	UNIT
$V_{CC1}, V_{CC2}$	Supply voltage <sup>(2)</sup>	-0.5	6	V
$IN_x, EN_x,$ $OUT_x$	Voltage	-0.5	$V_{CC} + 0.5$ <sup>(3)</sup>	V
$I_O$	Output current	-15	15	mA
$T_J$	Maximum junction temperature		150	°C
$T_{stg}$	Storage temperature	-65	150	°C

- (1) Stresses beyond those listed under Absolute Maximum Ratings may cause permanent damage to the device. These are stress ratings only, and functional operation of the device at these or any other conditions beyond those indicated under *Recommended Operating Conditions* is not implied. Exposure to absolute-maximum-rated conditions for extended periods may affect device reliability.
- (2) All voltage values except differential I/O bus voltages are with respect to the local ground terminal (GND1 or GND2) and are peak voltage values.
- (3) Maximum voltage must not exceed 6 V

### 6.2 ESD Ratings

		VALUE	UNIT
$V_{(ESD)}$	Electrostatic discharge		
	Human body model (HBM), per ANSI/ESDA/JEDEC JS-001 <sup>(1)</sup>	±4000	V
Charged-device model (CDM), per JEDEC specification JESD22-C101 <sup>(2)</sup>	±1500		

- (1) JEDEC document JEP155 states that 500-V HBM allows safe manufacturing with a standard ESD control process.
- (2) JEDEC document JEP157 states that 250-V CDM allows safe manufacturing with a standard ESD control process.

### 6.3 Recommended Operating Conditions

		MIN	NOM	MAX	UNIT
$V_{CC1}, V_{CC2}$	Supply voltage	2.7		5.5	V
$I_{OH}$	High-level output current ( $V_{CC} \geq 3.0$ V)	-4			mA
	High-level output current ( $V_{CC} < 3.0$ V)	-2			
$I_{OL}$	Low-level output current			4	mA
$V_{IH}$	High-level input voltage	2		5.5	V
$V_{IL}$	Low-level input voltage	0		0.8	
$t_{ui}$	Input pulse duration ( $V_{CC} \geq 4.5$ V)	20			ns
$t_{ui}$	Input pulse duration ( $V_{CC} < 4.5$ V)	25			
$1 / t_{ui}$	Signaling rate ( $V_{CC} \geq 4.5$ V)	0		50	Mbps
$1 / t_{ui}$	Signaling rate ( $V_{CC} < 4.5$ V)	0		40	
$T_A$	Ambient temperature	-40	25	125	°C
$T_J$	Junction temperature	-40		136	

## 6.4 Thermal Information

THERMAL METRIC <sup>(1)</sup>		ISO7131, ISO714x	UNIT
		DBQ	
		16 PINS	
R <sub>θJA</sub>	Junction-to-ambient thermal resistance	104.5	°C/W
R <sub>θJC(top)</sub>	Junction-to-case(top) thermal resistance	57.8	°C/W
R <sub>θJB</sub>	Junction-to-board thermal resistance	46.8	°C/W
ψ <sub>JT</sub>	Junction-to-top characterization parameter	18.3	°C/W
ψ <sub>JB</sub>	Junction-to-board characterization parameter	46.4	°C/W

(1) For more information about traditional and new thermal metrics, see the *IC Package Thermal Metrics* application report, [SPRA953](#).

## 6.5 Power Dissipation Ratings

	TEST CONDITIONS	VALUE	UNIT
P <sub>D</sub>	Device power dissipation V <sub>CC1</sub> = V <sub>CC2</sub> = 5.5 V, T <sub>J</sub> = 150°C, C <sub>L</sub> = 15 pF Input a 25-MHz, 50% duty cycle square wave	150	mW

## 6.6 Electrical Characteristics: V<sub>CC1</sub> and V<sub>CC2</sub> at 5 V ±10%

V<sub>CC1</sub> and V<sub>CC2</sub> at 5 V ± 10% (over recommended operating conditions unless otherwise noted.)

PARAMETER	TEST CONDITIONS	MIN	TYP	MAX	UNIT
V <sub>OH</sub>	I <sub>OH</sub> = -4 mA; see <a href="#">Figure 10</a>	V <sub>CCO</sub> <sup>(1)</sup> - 0.5	4.8		V
	I <sub>OH</sub> = -20 μA; see <a href="#">Figure 10</a>	V <sub>CCO</sub> <sup>(1)</sup> - 0.1	5		
V <sub>OL</sub>	I <sub>OL</sub> = 4 mA; see <a href="#">Figure 10</a>		0.2	0.4	V
	I <sub>OL</sub> = 20 μA; see <a href="#">Figure 10</a>		0	0.1	
V <sub>I(HYS)</sub>	Input threshold voltage hysteresis		450		mV
I <sub>IH</sub>	V <sub>IH</sub> = V <sub>CC</sub> at INx or ENx			10	μA
I <sub>IL</sub>	V <sub>IL</sub> = 0 V at INx or ENx	-10			μA
CMTI	V <sub>I</sub> = V <sub>CC</sub> or 0 V; see <a href="#">Figure 13</a>	25	75		kV/μs

(1) V<sub>CCO</sub> is the supply voltage, V<sub>CC1</sub> or V<sub>CC2</sub>, for the output channel that is being measured.

## 6.7 Electrical Characteristics: V<sub>CC1</sub> and V<sub>CC2</sub> at 3.3 V ±10%

V<sub>CC1</sub> and V<sub>CC2</sub> at 3.3 V ±10% (over recommended operating conditions unless otherwise noted.)

PARAMETER	TEST CONDITIONS	MIN	TYP	MAX	UNIT
V <sub>OH</sub>	I <sub>OH</sub> = -4 mA; see <a href="#">Figure 10</a>	V <sub>CCO</sub> <sup>(1)</sup> - 0.5	3		V
	I <sub>OH</sub> = -20 μA; see <a href="#">Figure 10</a>	V <sub>CCO</sub> <sup>(1)</sup> - 0.1	3.3		
V <sub>OL</sub>	I <sub>OL</sub> = 4 mA; see <a href="#">Figure 10</a>		0.2	0.4	V
	I <sub>OL</sub> = 20 μA; see <a href="#">Figure 10</a>		0	0.1	
V <sub>I(HYS)</sub>	Input threshold voltage hysteresis		425		mV
I <sub>IH</sub>	V <sub>IH</sub> = V <sub>CC</sub> at INx or ENx			10	μA
I <sub>IL</sub>	V <sub>IL</sub> = 0 V at INx or ENx	-10			μA
CMTI	V <sub>I</sub> = V <sub>CC</sub> or 0 V; see <a href="#">Figure 13</a>	25	50		kV/μs

(1) V<sub>CCO</sub> is the supply voltage, V<sub>CC1</sub> or V<sub>CC2</sub>, for the output channel that is being measured.

## 6.8 Electrical Characteristics: $V_{CC1}$ and $V_{CC2}$ at 2.7 V

$V_{CC1}$  and  $V_{CC2}$  at 2.7 V (over recommended operating conditions unless otherwise noted.)

PARAMETER		TEST CONDITIONS	MIN	TYP	MAX	UNIT
$V_{OH}$	High-level output voltage	$I_{OH} = -2$ mA; see <a href="#">图 10</a>	$V_{CCO}^{(1)} - 0.3$	2.5		V
		$I_{OH} = -20$ $\mu$ A; see <a href="#">图 10</a>	$V_{CCO}^{(1)} - 0.1$	2.7		
$V_{OL}$	Low-level output voltage	$I_{OL} = 4$ mA; see <a href="#">图 10</a>		0.2	0.4	V
		$I_{OL} = 20$ $\mu$ A; see <a href="#">图 10</a>		0	0.1	
$V_{I(HYS)}$	Input threshold voltage hysteresis			350		mV
$I_{IH}$	High-level input current	$V_{IH} = V_{CC}$ at INx or ENx			10	$\mu$ A
$I_{IL}$	Low-level input current	$V_{IL} = 0$ V at INx or ENx	-10			$\mu$ A
CMTI	Common-mode transient immunity	$V_I = V_{CC}$ or 0 V; see <a href="#">图 13</a>	25	50		kV/ $\mu$ s

(1)  $V_{CCO}$  is the supply voltage,  $V_{CC1}$  or  $V_{CC2}$ , for the output channel that is being measured.

## 6.9 Switching Characteristics: $V_{CC1}$ and $V_{CC2}$ at 5 V $\pm$ 10%

$V_{CC1}$  and  $V_{CC2}$  at 5 V  $\pm$ 10% (over recommended operating conditions unless otherwise noted.)

PARAMETER		TEST CONDITIONS	MIN	TYP	MAX	UNIT
$t_{PLH}$ , $t_{PHL}$	Propagation delay time	See <a href="#">图 10</a>	12	19	35	ns
PWD <sup>(1)</sup>	Pulse width distortion $ t_{PHL} - t_{PLH} $		3			
$t_{sk(o)}$ <sup>(2)</sup>	Channel-to-channel output skew time	Same-direction channels			2	ns
		Opposite-direction channels			4	
$t_{sk(pp)}$ <sup>(3)</sup>	Part-to-part skew time				12	ns
$t_r$	Output signal rise time	See <a href="#">图 10</a>		2		ns
$t_f$	Output signal fall time			2		ns
$t_{PHZ}$ , $t_{PLZ}$	Disable propagation delay, high/low-to-high impedance output	See <a href="#">图 11</a>		6	10	ns
$t_{PZH}$ , $t_{PZL}$	Enable propagation delay, high impedance-to-high/low output			5	10	ns
$t_{fs}$	Fail-safe output delay time from input data or power loss	See <a href="#">图 12</a>		9.5		$\mu$ s
$t_{GR}$	Input glitch rejection time			11		ns

(1) Also known as pulse skew

(2)  $t_{sk(o)}$  is the skew between outputs of a single device with all driving inputs connected together and the outputs switching in the same direction while driving identical loads.

(3)  $t_{sk(pp)}$  is the magnitude of the difference in propagation delay times between any terminals of different devices switching in the same direction while operating at identical supply voltages, temperature, input signals, and loads.

## 6.10 Switching Characteristics: $V_{CC1}$ and $V_{CC2}$ at 3.3 V $\pm$ 10%

 $V_{CC1}$  and  $V_{CC2}$  at 3.3 V  $\pm$ 10% (over recommended operating conditions unless otherwise noted.)

PARAMETER		TEST CONDITIONS	MIN	TYP	MAX	UNIT
$t_{PLH}$ , $t_{PHL}$	Propagation delay time	See 图 10	15	23	45	ns
PWD <sup>(1)</sup>	Pulse width distortion $ t_{PHL} - t_{PLH} $					
$t_{sk(o)}$ <sup>(2)</sup>	Channel-to-channel output skew time	Same-direction Channels			2	ns
		Opposite-direction Channels			4	
$t_{sk(pp)}$ <sup>(3)</sup>	Part-to-part skew time				19	ns
$t_r$	Output signal rise time	See 图 10		2.5		ns
$t_f$	Output signal fall time			2.5		ns
$t_{PHZ}$ , $t_{PLZ}$	Disable propagation delay, from high/low to high-impedance output	See 图 11		6.5	15	ns
$t_{PZH}$ , $t_{PZL}$	Enable propagation delay, from high-impedance to high/low output			6.5	15	ns
$t_{fs}$	Fail-safe output delay time from input data or power loss	See 图 12		8		$\mu$ s
$t_{GR}$	Input glitch rejection time			12.5		ns

(1) Also known as pulse skew

(2)  $t_{sk(o)}$  is the skew between outputs of a single device with all driving inputs connected together and the outputs switching in the same direction while driving identical loads.

(3)  $t_{sk(pp)}$  is the magnitude of the difference in propagation delay times between any terminals of different devices switching in the same direction while operating at identical supply voltages, temperature, input signals and loads.

## 6.11 Switching Characteristics: $V_{CC1}$ and $V_{CC2}$ at 2.7 V

 $V_{CC1}$  and  $V_{CC2}$  at 2.7 V (over recommended operating conditions unless otherwise noted.)

PARAMETER		TEST CONDITIONS	MIN	TYP	MAX	UNIT
$t_{PLH}$ , $t_{PHL}$	Propagation delay time	See 图 10	15	27	50	ns
PWD <sup>(1)</sup>	Pulse width distortion $ t_{PHL} - t_{PLH} $					
$t_{sk(o)}$ <sup>(2)</sup>	Channel-to-channel output skew time	Same-direction Channels			2	ns
		Opposite-direction Channels			4	
$t_{sk(pp)}$ <sup>(3)</sup>	Part-to-part skew time				22	ns
$t_r$	Output signal rise time	See 图 10		3		ns
$t_f$	Output signal fall time			3		ns
$t_{PHZ}$ , $t_{PLZ}$	Disable propagation delay, from high/low to high-impedance output	See 图 11		9	15	ns
$t_{PZH}$ , $t_{PZL}$	Enable propagation delay, from high-impedance to high/low output			9	15	ns
$t_{fs}$	Fail-safe output delay time from input data or power loss	See 图 12		8.5		$\mu$ s
$t_{GR}$	Input glitch rejection time			14		ns

(1) Also known as pulse skew

(2)  $t_{sk(o)}$  is the skew between outputs of a single device with all driving inputs connected together and the outputs switching in the same direction while driving identical loads.

(3)  $t_{sk(pp)}$  is the magnitude of the difference in propagation delay times between any terminals of different devices switching in the same direction while operating at identical supply voltages, temperature, input signals, and loads.

## 6.12 Supply Current: $V_{CC1}$ and $V_{CC2}$ at 5 V $\pm 10\%$

$V_{CC1}$  and  $V_{CC2}$  at 5 V  $\pm 10\%$  (over recommended operating conditions unless otherwise noted.)

PARAMETER	TEST CONDITIONS		MIN	TYP	MAX	UNIT		
<b>ISO7131</b>								
$I_{CC1}$	Disable	EN1 = EN2 = 0 V		2.2	3.7	mA		
$I_{CC2}$				3.7	5			
$I_{CC1}$	DC to 1 Mbps	DC signal: $V_I = V_{CC}$ or 0 V AC signal: All channels switching with square-wave clock input; $C_L = 15$ pF		2.2	3.7	mA		
$I_{CC2}$				3.7	5			
$I_{CC1}$	10 Mbps			3.4	4.8			
$I_{CC2}$				4.9	6.6			
$I_{CC1}$	25 Mbps			4.9	6.6			
$I_{CC2}$				6.8	9			
$I_{CC1}$	50 Mbps			7.1	10			
$I_{CC2}$				10.5	13			
<b>ISO7140</b>								
$I_{CC1}$	Disable		EN = 0 V		0.6		1.2	mA
$I_{CC2}$				4.6	7			
$I_{CC1}$	DC to 1 Mbps	DC Signal: $V_I = V_{CC}$ or 0 V, AC Signal: All channels switching with square wave clock input; $C_L = 15$ pF		0.6	1.3	mA		
$I_{CC2}$				4.8	7			
$I_{CC1}$	10 Mbps			1.4	2.2			
$I_{CC2}$				6.9	9.2			
$I_{CC1}$	25 Mbps			2.7	3.9			
$I_{CC2}$				10.3	13.5			
$I_{CC1}$	50 Mbps			4.7	6.5			
$I_{CC2}$				15.6	21			
<b>ISO7141</b>								
$I_{CC1}$	Disable		EN1 = EN2 = 0V		2.5		4.2	mA
$I_{CC2}$				4.2	7			
$I_{CC1}$	DC to 1 Mbps	DC signal: $V_I = V_{CC}$ or 0 V, AC signal: All channels switching with square wave clock input; $C_L = 15$ pF		2.5	4.2	mA		
$I_{CC2}$				4.2	7			
$I_{CC1}$	10 Mbps			3.8	5.3			
$I_{CC2}$				6.2	9.6			
$I_{CC1}$	25 Mbps			5.6	7.5			
$I_{CC2}$				9.2	13			
$I_{CC1}$	50 Mbps			8.4	11.2			
$I_{CC2}$				14	18.5			

### 6.13 Supply Current: $V_{CC1}$ and $V_{CC2}$ at 3.3 V $\pm$ 10%

 $V_{CC1}$  and  $V_{CC2}$  at 3.3 V  $\pm$ 10% (over recommended operating conditions unless otherwise noted.)

PARAMETER	TEST CONDITIONS		MIN	TYP	MAX	UNIT		
<b>ISO7131</b>								
$I_{CC1}$	Disable	EN1 = EN2 = 0 V		1.9	2.7	mA		
$I_{CC2}$				2.6	3.8			
$I_{CC1}$	DC to 1 Mbps	DC signal: $V_I = V_{CC}$ or 0 V AC signal: All channels switching with square-wave clock input; $C_L = 15$ pF		1.9	2.7	mA		
$I_{CC2}$				2.6	3.8			
$I_{CC1}$	10 Mbps			2.4	3.5			
$I_{CC2}$				3.5	4.7			
$I_{CC1}$	25 Mbps			3.2	4.6			
$I_{CC2}$				4.7	6.2			
$I_{CC1}$	40 Mbps			5	7			
$I_{CC2}$				7	9			
<b>ISO7140</b>								
$I_{CC1}$	Disable		EN = 0 V		0.3		0.7	mA
$I_{CC2}$				3.6	5.2			
$I_{CC1}$	DC to 1 Mbps	DC signal: $V_I = V_{CC}$ or 0 V, AC signal: All channels switching with square-wave clock input; $C_L = 15$ pF		0.4	0.8	mA		
$I_{CC2}$				3.7	5.3			
$I_{CC1}$	10 Mbps			0.9	1.4			
$I_{CC2}$				5.1	6.8			
$I_{CC1}$	25 Mbps			1.7	2.4			
$I_{CC2}$				7.3	10			
$I_{CC1}$	40 Mbps			2.4	3.7			
$I_{CC2}$				9.4	13			
<b>ISO7141</b>								
$I_{CC1}$	Disable		EN1 = EN2 = 0 V		2		3.1	mA
$I_{CC2}$				3.2	4.9			
$I_{CC1}$	DC to 1 Mbps	DC signal: $V_I = V_{CC}$ or 0 V, AC signal: All channels switching with square-wave clock input; $C_L = 15$ pF		2	3.1	mA		
$I_{CC2}$				3.2	4.9			
$I_{CC1}$	10 Mbps			2.8	3.8			
$I_{CC2}$				4.5	6.1			
$I_{CC1}$	25 Mbps			4	5.2			
$I_{CC2}$				6.4	8.3			
$I_{CC1}$	40 Mbps			5	8			
$I_{CC2}$				8.2	11.6			

## 6.14 Supply Current: $V_{CC1}$ and $V_{CC2}$ at 2.7 V

 $V_{CC1}$  and  $V_{CC2}$  at 2.7 V (over recommended operating conditions unless otherwise noted.)

PARAMETER	TEST CONDITIONS		MIN	TYP	MAX	UNIT		
<b>ISO7131</b>								
$I_{CC1}$	Disable	EN1 = EN2 = 0 V		1.2	2.4	mA		
$I_{CC2}$				2.3	3.3			
$I_{CC1}$	DC to 1 Mbps	DC signal: $V_I = V_{CC}$ or 0 V AC signal: All channels switching with square-wave clock input; $C_L = 15$ pF		1.2	2.4	mA		
$I_{CC2}$				2.3	3.3			
$I_{CC1}$	10 Mbps			2.1	3			
$I_{CC2}$				2.9	4			
$I_{CC1}$	25 Mbps			3	3.8			
$I_{CC2}$				4	5.2			
$I_{CC1}$	40 Mbps			4.2	5.3			
$I_{CC2}$				5.8	7			
<b>ISO7140</b>								
$I_{CC1}$	Disable		EN = 0 V		0.2		0.4	mA
$I_{CC2}$				3.2	4.7			
$I_{CC1}$	DC to 1 Mbps	DC signal: $V_I = V_{CC}$ or 0 V, AC signal: All channels switching with square-wave clock input; $C_L = 15$ pF		0.2	0.5	mA		
$I_{CC2}$				3.4	4.8			
$I_{CC1}$	10 Mbps			0.6	1			
$I_{CC2}$				4.5	6.3			
$I_{CC1}$	25 Mbps			1.2	1.8			
$I_{CC2}$				6.2	8			
$I_{CC1}$	40 Mbps			1.8	2.6			
$I_{CC2}$				8	11			
<b>ISO7141</b>								
$I_{CC1}$	Disable		EN1 = EN2 = 0 V		1.6		2.6	mA
$I_{CC2}$				2.8	4.1			
$I_{CC1}$	DC to 1 Mbps	DC signal: $V_I = V_{CC}$ or 0 V, AC signal: All channels switching with square-wave clock input; $C_L = 15$ pF		1.6	2.6	mA		
$I_{CC2}$				2.8	4.1			
$I_{CC1}$	10 Mbps			2.3	3.2			
$I_{CC2}$				3.8	5			
$I_{CC1}$	25 Mbps			3.3	4.2			
$I_{CC2}$				5.4	6.8			
$I_{CC1}$	40 Mbps			4.3	5.8			
$I_{CC2}$				6.9	9.2			

### 6.15 Typical Characteristics



图 1. ISO7131 Supply Current for All Channels vs Data Rate



图 2. ISO7140 Supply Current for All Channels vs Data Rate

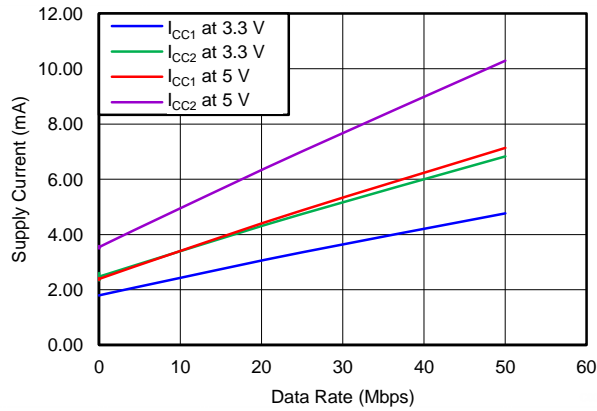

图 3. ISO7141 Supply Current for All Channels vs Data Rate

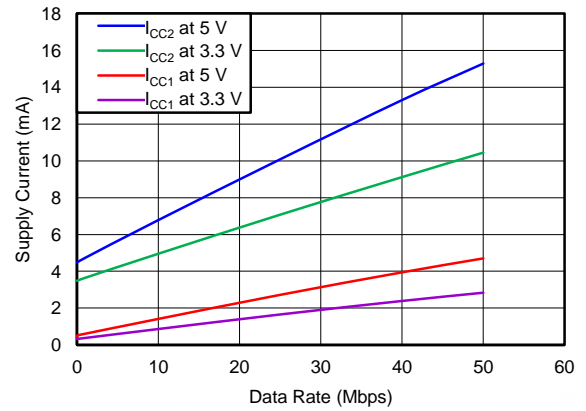

图 4. High-Level Output Voltage vs High-Level Output Current

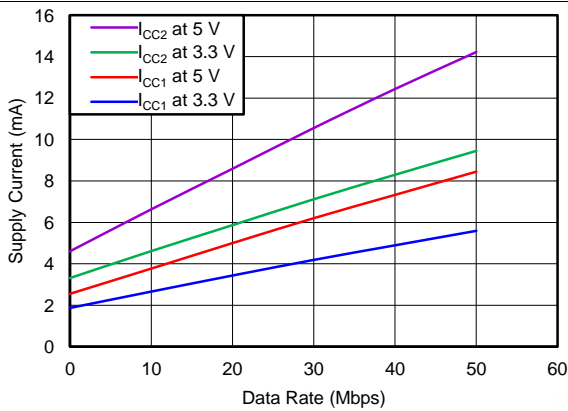

图 5. Low-Level Output Voltage vs Low-Level Output Current

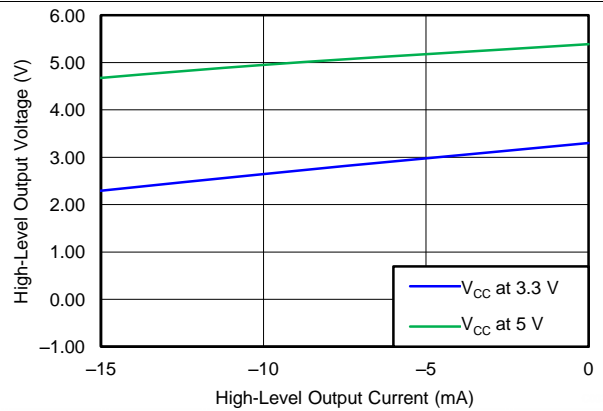

图 6. V<sub>CC</sub> Undervoltage Threshold vs Free-Air Temperature

Typical Characteristics (接下页)

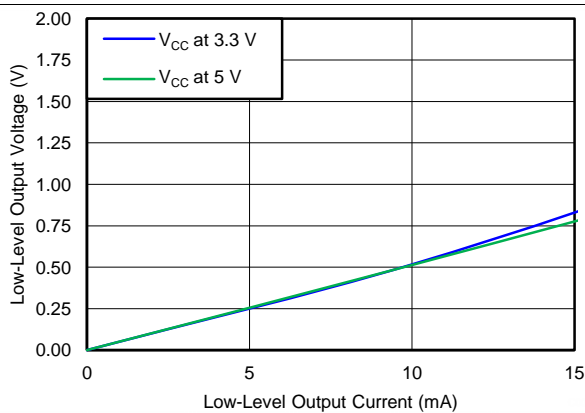

## 7 Parameter Measurement Information

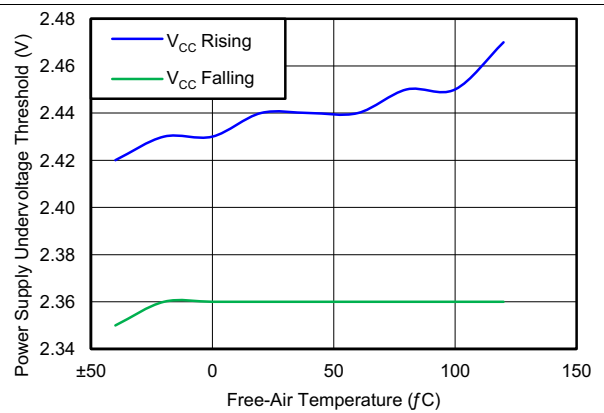
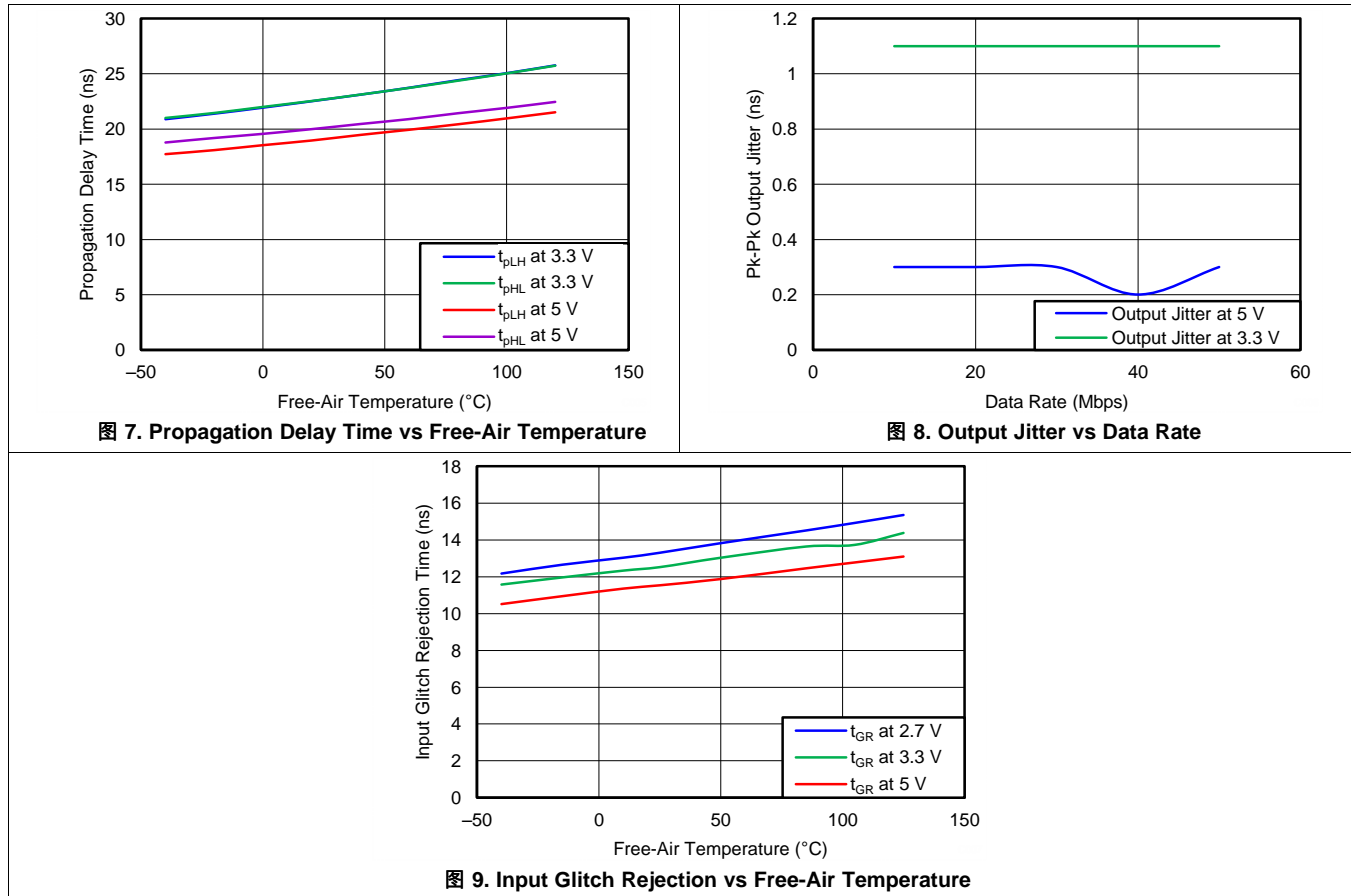
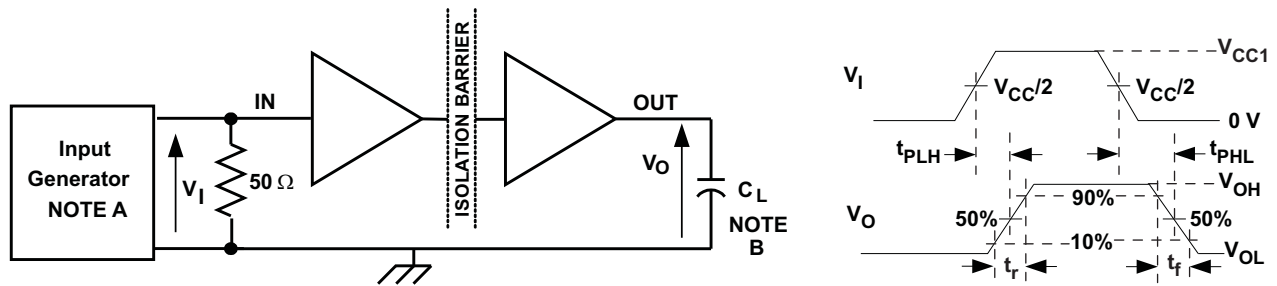

- A. The input pulse is supplied by a generator having the following characteristics: PRR  $\leq$  50 kHz, 50% duty cycle,  $t_r \leq 3$  ns,  $t_f \leq 3$  ns,  $Z_O = 50 \Omega$ . At the input, a 50- $\Omega$  resistor is required to terminate the input-generator signal. It is not needed in an actual application.
- B.  $C_L = 15$  pF and includes instrumentation and fixture capacitance within  $\pm 20\%$ .

**图 10. Switching-Characteristics Test Circuit and Voltage Waveforms**

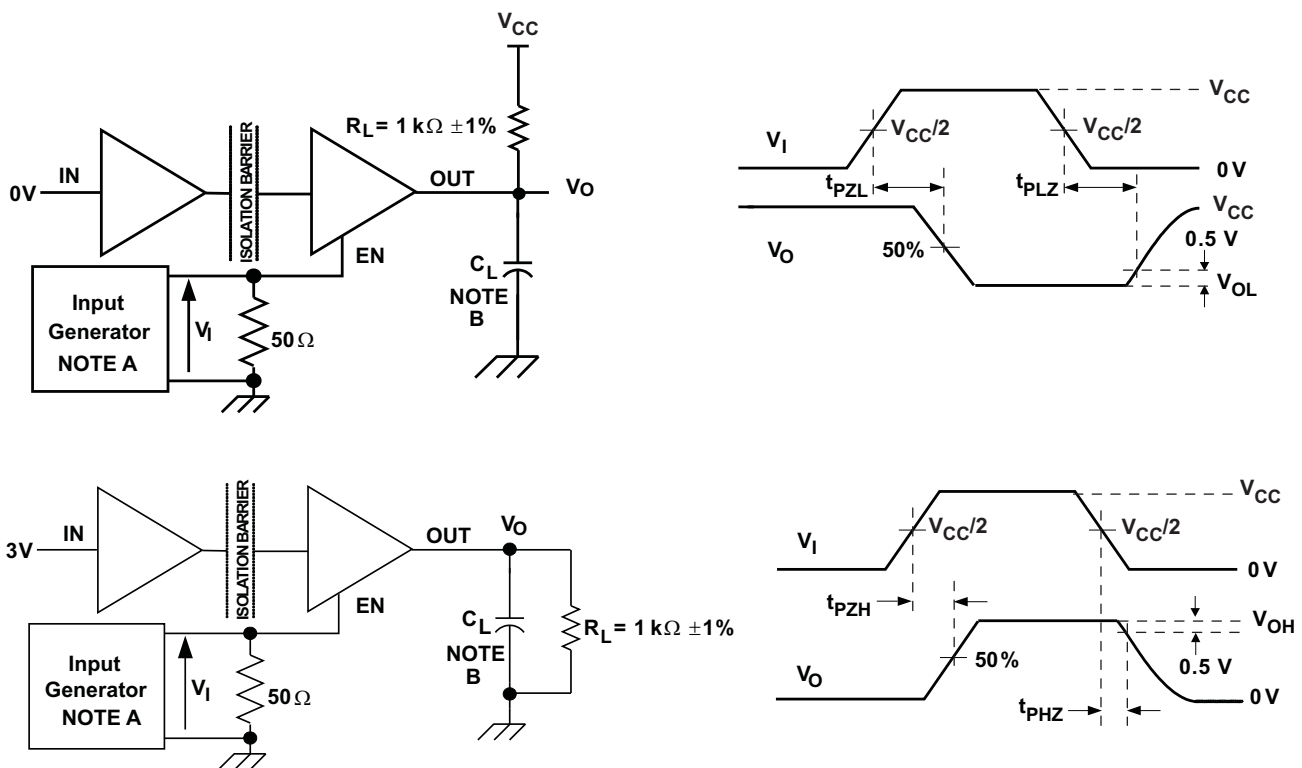

- A. The input pulse is supplied by a generator having the following characteristics: PRR  $\leq$  50 kHz, 50% duty cycle,  $t_r \leq 3$  ns,  $t_f \leq 3$  ns,  $Z_O = 50 \Omega$ .
- B.  $C_L = 15$  pF and includes instrumentation and fixture capacitance within  $\pm 20\%$ .

**图 11. Enable/Disable Propagation Delay-Time Test Circuit and Waveform**

Parameter Measurement Information (接下页)

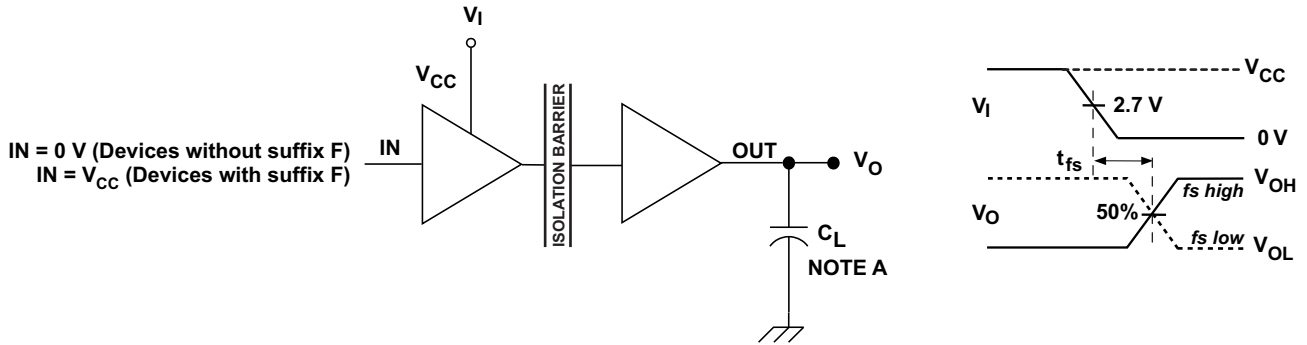

A. C<sub>L</sub> = 15 pF and includes instrumentation and fixture capacitance within ±20%.

图 12. Failsafe Delay-Time Test Circuit and Voltage Waveforms

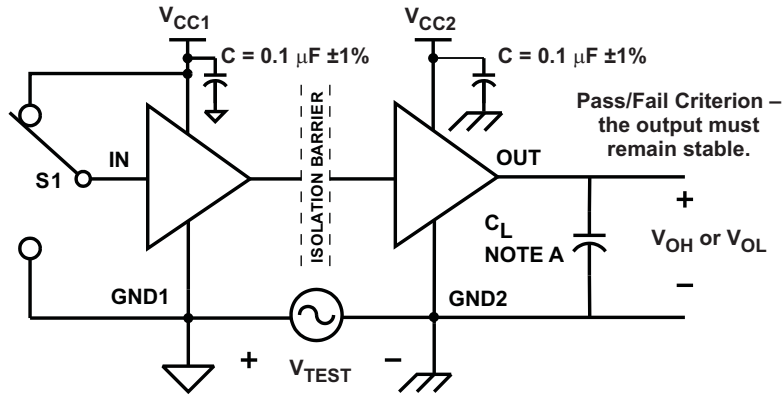

A. C<sub>L</sub> = 15 pF and includes instrumentation and fixture capacitance within ±20%.

图 13. Common-Mode Transient Immunity Test Circuit

## 8 Detailed Description

### 8.1 Overview

The isolator in 图 14 is based on a capacitive isolation barrier technique. The I/O channel of the device consists of two internal data channels, a high-frequency channel (HF) with a bandwidth from 100 kbps up to 150 Mbps, and a low-frequency channel (LF) covering the range from 100 kbps down to DC. In principle, a single-ended input signal entering the HF-channel is split into a differential signal through the inverter gate at the input. The following capacitor-resistor networks differentiate the signal into transients, which then are converted into differential pulses by two comparators. The comparator outputs drive a NOR-gate flip-flop whose output feeds an output multiplexer. A decision logic (DCL) at the driving output of the flip-flop measures the durations between signal transients. If the duration between two consecutive transients exceeds a certain time limit, (as in the case of a low-frequency signal), the DCL forces the output-multiplexer to switch from the high- to the low-frequency channel.

Because low-frequency input signals require the internal capacitors to assume prohibitively large values, these signals are pulse-width modulated (PWM) with the carrier frequency of an internal oscillator, thus creating a sufficiently high frequency signal, capable of passing the capacitive barrier. As the input is modulated, a low-pass filter (LPF) is needed to remove the high-frequency carrier from the actual data before passing it on to the output multiplexer.

### 8.2 Functional Block Diagram



图 14. Conceptual Block Diagram of a Digital Capacitive Isolator

### 8.3 Feature Description

**表 1. Product Features**

PRODUCT	RATED ISOLATION	INPUT THRESHOLD	DEFAULT OUTPUT	MAX DATA RATE and INPUT FILTER	CHANNEL DIRECTION
ISO7131CC	4242 V <sub>PK</sub> <sup>(1)</sup>	1.5-V TTL (CMOS compatible)	High	50 Mbps, with noise filter integrated	2 forward, 1 reverse
ISO7140CC			Low		4 forward, 0 reverse
ISO7140FCC			High		3 forward, 1 reverse
ISO7141CC			Low		
ISO7141FCC					

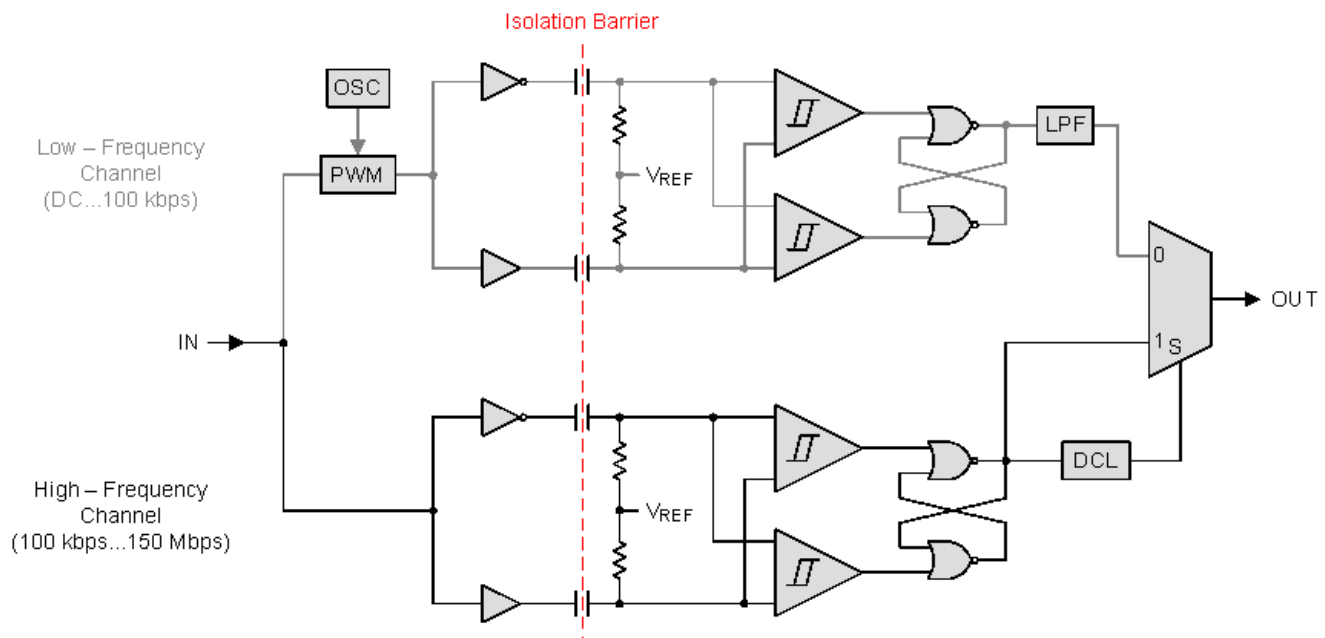
(1) See [Regulatory Information](#) for detailed Isolation Ratings.

#### 8.3.1 Insulation and Safety-Related Specifications

PARAMETER		TEST CONDITIONS	MIN	TYP	MAX	UNIT
V <sub>IOTM</sub>	Maximum transient overvoltage per DIN V VDE V 0884-10 (VDE V 0884-10):2006-12				4242	V <sub>PK</sub>
V <sub>IORM</sub>	Maximum working voltage per DIN V VDE V 0884-10 (VDE V 0884-10):2006-12				566	V <sub>PK</sub>
V <sub>ISO</sub>	Isolation Voltage per UL 1577	V <sub>TEST</sub> = V <sub>ISO</sub> , t = 60 sec (qualification)			2500	V <sub>RMS</sub>
		V <sub>TEST</sub> = 1.2 * V <sub>ISO</sub> , t = 1 sec (100% production)			3000	
V <sub>PR</sub>	Input-to-output test voltage per DIN V VDE V 0884-10 (VDE V 0884-10):2006-12	After Input/Output safety test subgroup 2/3, V <sub>PR</sub> = V <sub>IORM</sub> × 1.2, t = 10 s, Partial discharge < 5 pC			679	V <sub>PK</sub>
		Method a, After environmental tests subgroup 1, V <sub>PR</sub> = V <sub>IORM</sub> × 1.6, t = 10 s, Partial discharge < 5 pC			906	
		Method b1, 100% production test, V <sub>PR</sub> = V <sub>IORM</sub> × 1.875, t = 1 s, Partial discharge < 5 pC			1061	
L(I01)	Minimum air gap (clearance)	Shortest terminal to terminal distance through air	3.7			mm
L(I02)	Minimum external tracking (creepage)	Shortest terminal to terminal distance across the package surface	3.7			mm
	Minimum internal gap (internal clearance)	Distance through the insulation	0.014			mm
	Pollution degree			2		
CTI	Tracking resistance (comparative tracking index)	DIN IEC 60112 / VDE 0303 Part 1	≥400			V
R <sub>IO</sub> <sup>(1)</sup>	Isolation Resistance, Input to Output	V <sub>IO</sub> = 500 V, T <sub>A</sub> = 25°C		>10 <sup>12</sup>		Ω
		V <sub>IO</sub> = 500 V, 100°C ≤ T <sub>A</sub> ≤ T <sub>A</sub> max		>10 <sup>11</sup>		
C <sub>IO</sub> <sup>(1)</sup>	Barrier capacitance, input to output	V <sub>I</sub> = 0.4 sin (2πft), f = 1 MHz		2.3		pF
C <sub>I</sub> <sup>(2)</sup>	Input capacitance	V <sub>I</sub> = V <sub>CC</sub> /2 + 0.4 sin (2πft), f = 1 MHz, V <sub>CC</sub> = 5 V		2.8		pF

(1) All pins on each side of the barrier tied together creating a two-terminal device.

(2) Measured from input pin to ground.

注

Creepage and clearance requirements should be applied according to the specific equipment isolation standards of an application. Care should be taken to maintain the creepage and clearance distance of a board design to ensure that the mounting pads of the isolator on the printed-circuit-board (PCB) do not reduce this distance.

Creepage and clearance on a PCB become equal in certain cases. Techniques such as inserting grooves and/or ribs on a PCB are used to help increase these specifications.

表 2. IEC 60664-1 Ratings Table

PARAMETER	TEST CONDITIONS	SPECIFICATION
Basic Isolation Group	Material Group	II
Installation classification	Rated mains voltage $\leq 150 V_{RMS}$	I-IV
	Rated mains voltage $\leq 300 V_{RMS}$	I-III
	Rated mains voltage $\leq 400 V_{RMS}$	I-II

8.3.1.1 Safety Limiting Values

Safety limiting intends to prevent potential damage to the isolation barrier upon failure of input or output circuitry. A failure of the IO can allow low resistance to ground or the supply and, without current limiting, dissipate sufficient power to overheat the die and damage the isolation barrier, potentially leading to secondary system failures.

PARAMETER	TEST CONDITIONS	MIN	TYP	MAX	UNIT	
$I_S$ Safety input, output, or supply current	DBQ-16 $R_{\theta JA} = 104.5^{\circ}C/W, V_I = 5.5V, T_J = 150^{\circ}C, T_A = 25^{\circ}C$	$R_{\theta JA} = 104.5^{\circ}C/W, V_I = 5.5V, T_J = 150^{\circ}C, T_A = 25^{\circ}C$			217	mA
		$R_{\theta JA} = 104.5^{\circ}C/W, V_I = 3.6V, T_J = 150^{\circ}C, T_A = 25^{\circ}C$			332	
		$R_{\theta JA} = 104.5^{\circ}C/W, V_I = 2.7V, T_J = 150^{\circ}C, T_A = 25^{\circ}C$			443	
$T_S$ Maximum case temperature					150	$^{\circ}C$

The safety-limiting constraint is the absolute-maximum junction temperature specified in the [Absolute Maximum Ratings<sup>\(1\)</sup>](#) table. The power dissipation and junction-to-air thermal impedance of the device installed in the application hardware determines the junction temperature. The assumed junction-to-air thermal resistance in the [Thermal Information](#) table is that of a device installed on a high-K test board for leaded surface-mount packages. The power is the recommended maximum input voltage times the current. The junction temperature is then the ambient temperature plus the power times the junction-to-air thermal resistance.



图 15. DBQ-16  $\theta_{JC}$  Thermal Derating Curve

(1) Stresses beyond those listed under Absolute Maximum Ratings may cause permanent damage to the device. These are stress ratings only, and functional operation of the device at these or any other conditions beyond those indicated under [Recommended Operating Conditions](#) is not implied. Exposure to absolute-maximum-rated conditions for extended periods may affect device reliability.

### 8.3.1.2 Regulatory Information

VDE	UL	CSA	CQC
Certified according to DIN V VDE V 0884-10 (VDE V 0884-10):2006-12 and DIN EN 61010-1	Recognized under UL 1577 Component Recognition Program	Approved under CSA Component Acceptance Notice 5A, IEC 60950-1, and IEC 61010-1	Certified according to GB 4943.1-2011
Basic Insulation Maximum Transient Overvoltage, 4242 V <sub>PK</sub> Maximum Working Voltage, 566 V <sub>PK</sub>	Single protection, 2500 V <sub>RMS</sub> <sup>(1)</sup>	Reinforced Insulation per CSA 60950-1-03 and IEC 60950-1 (2nd Ed.), 185 V <sub>RMS</sub> maximum working voltage Basic Insulation per CSA 60950-1-03 and IEC 60950-1 (2nd Ed.), 370 V <sub>RMS</sub> maximum working voltage Reinforced Insulation per CSA 61010-1-12 and IEC 61010-1 (3rd Edition), 150 V <sub>RMS</sub> maximum working voltage Basic Insulation per CSA 61010-1-12 and IEC 61010-1 (3rd Edition), 300 V <sub>RMS</sub> maximum working voltage	Basic Insulation, Altitude ≤ 5000m, Tropical Climate, 250 V <sub>RMS</sub> maximum working voltage
Certificate number: 40016131	File number: E181974	Master contract number: 220991	Certificate number: CQC14001109540

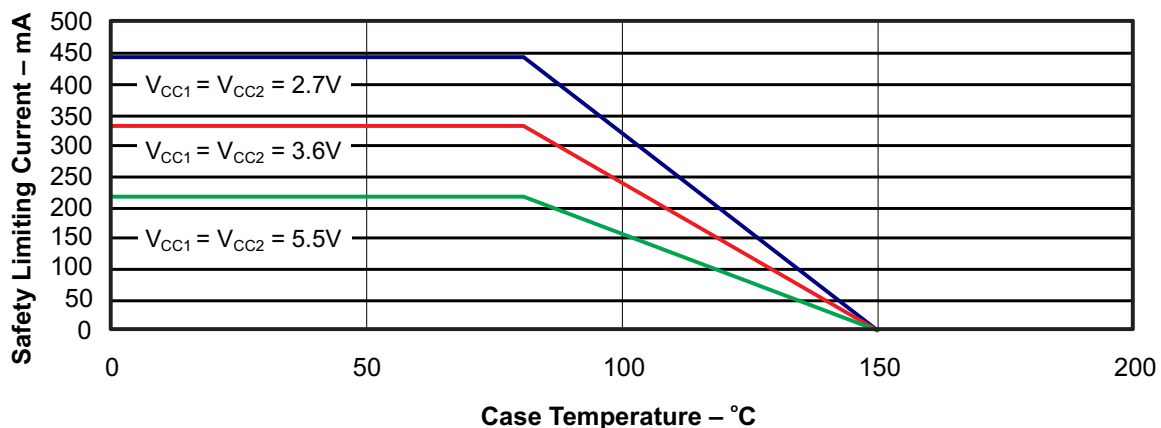
(1) Production tested ≥ 3000 Vrms for 1 second in accordance with UL 1577.

## 8.4 Device Functional Modes

表 3. Function Table<sup>(1)</sup>

V <sub>CCI</sub>	V <sub>CCO</sub>	INPUT (INx)	OUTPUT ENABLE (ENx)	OUTPUT (OUTx)	
				ISO71xxCC	ISO71xxFCC
PU	PU	H	H or open	H	H
		L	H or open	L	L
		X	L	Z	Z
		Open	H or open	H	L
PD	PU	X	H or open	H	L
PD	PU	X	L	Z	Z
PU	PD	X	X	Undetermined	Undetermined

(1) V<sub>CCI</sub> = Input-side V<sub>CC</sub>; V<sub>CCO</sub> = Output-side V<sub>CC</sub>; PU = Powered Up (V<sub>CC</sub> ≥ 2.7 V); PD = Powered Down (V<sub>CC</sub> ≤ 2.1 V); X = Irrelevant; H = High Level; L = Low Level; Z = High Impedance



图 16. Device I/O Schematics

## 9 Application and Implementation

### 注

Information in the following applications sections is not part of the TI component specification, and TI does not warrant its accuracy or completeness. TI's customers are responsible for determining suitability of components for their purposes. Customers should validate and test their design implementation to confirm system functionality.

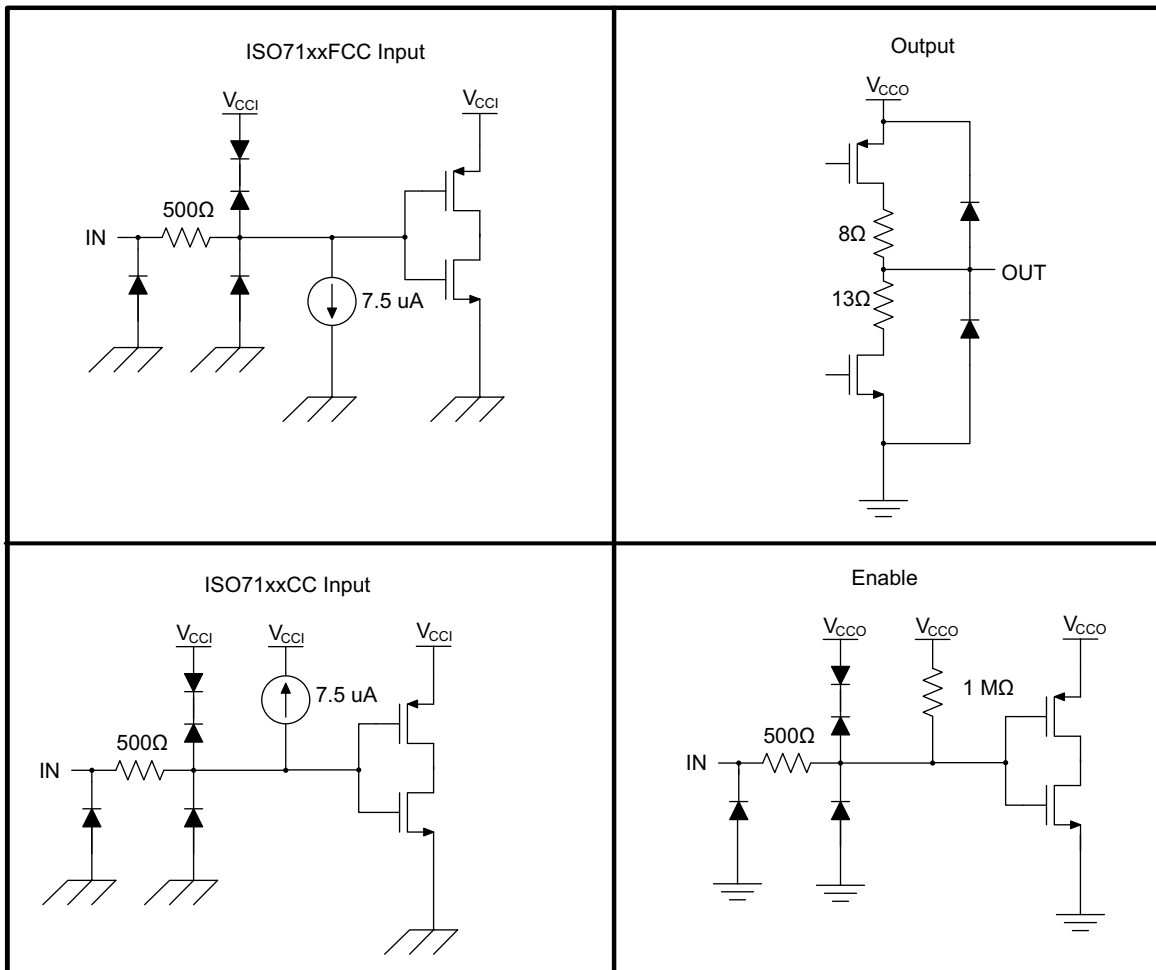
### 9.1 Application Information

ISO71xx use single-ended TTL-logic switching technology. Its supply voltage range is from 3 V to 5.5 V for both supplies,  $V_{CC1}$  and  $V_{CC2}$ . When designing with digital isolators, it is important to note that due to the single-ended design structure, digital isolators do not conform to any specific interface standard and are only intended for isolating single-ended CMOS or TTL digital signal lines. The isolator is typically placed between the data controller (that is,  $\mu C$  or UART), and a data converter or a line transceiver, regardless of the interface type or standard.

### 9.2 Typical Applications

#### 9.2.1 Isolated Data Acquisition System for Process Control

ISO71xx combined with TI's precision analog-to-digital converter and mixed signal micro-controller can create an advanced isolated data acquisition system as shown in 图 17.



图 17. Isolated Data Acquisition System for Process Control

## Typical Applications (接下页)

### 9.2.1.1 Design Requirements

Unlike optocouplers, which need external components to improve performance, provide bias, or limit current, ISO71xx only needs two external bypass capacitors to operate.

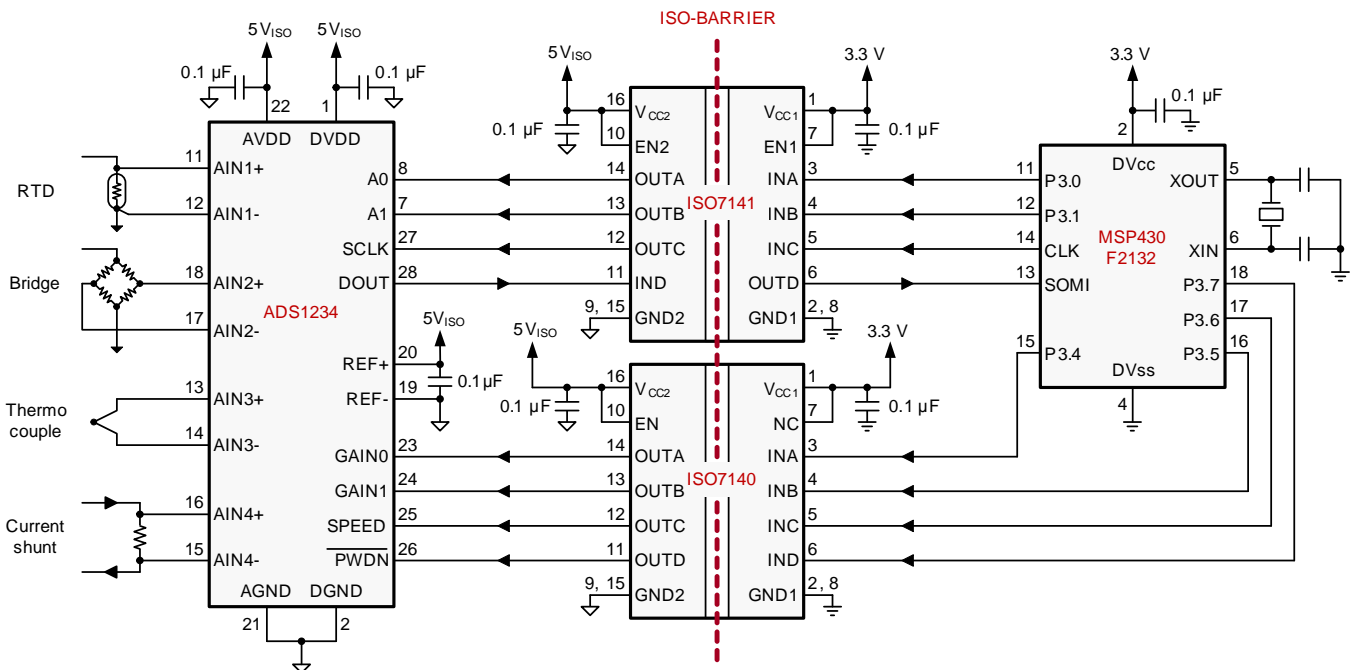
### 9.2.1.2 Detailed Design Procedure



图 18. Typical ISO7131 Circuit Hook-up



图 19. Typical ISO7140 Circuit Hook-up

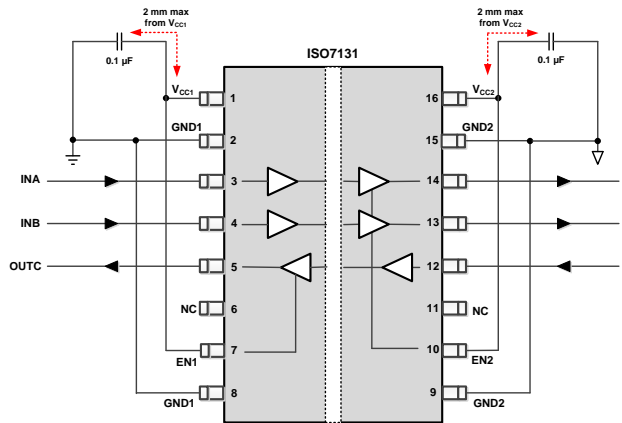

图 20. Typical ISO7141 Circuit Hook-up

Typical Applications (接下页)

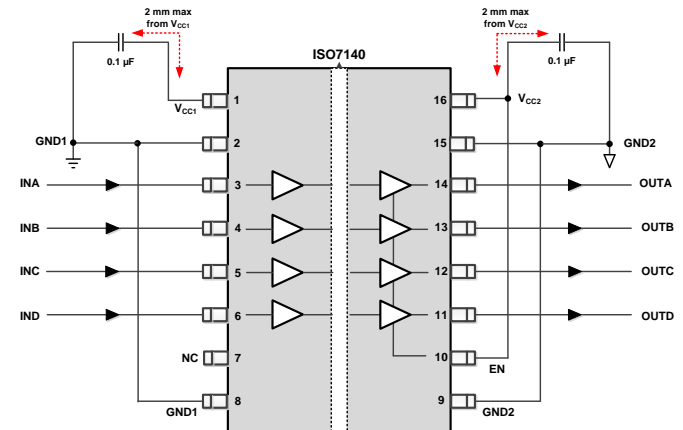
9.2.1.3 Application Curves

Typical eye diagrams of ISO71xx (see 图 21, 图 22, and 图 23) indicate low jitter and wide open eye at the maximum data rate.

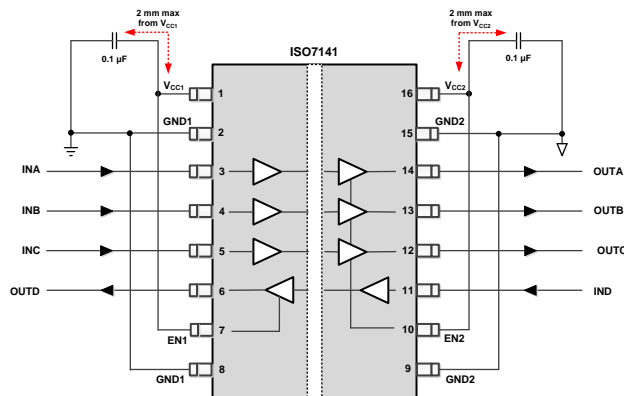

图 21. Typical Eye Diagram at 40 MBPS, PRBS 2<sup>16</sup> - 1, 2.7-V Operation



图 22. Typical Eye Diagram at 40 MBPS, PRBS 2<sup>16</sup> - 1, 3.3-V Operation

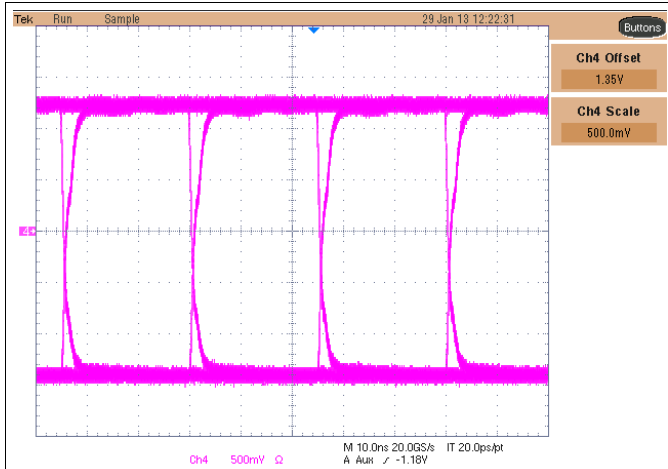

图 23. Typical Eye Diagram at 50 MBPS, PRBS 2<sup>16</sup> - 1, 5-V Operation

**Typical Applications (接下页)**
**9.2.2 Isolated RS-485 Interface**

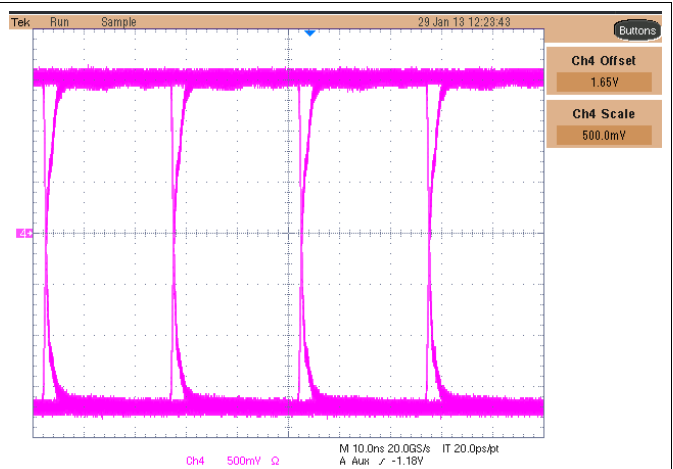
**图 24. Isolated RS-485 Interface**
**9.2.2.1 Design Requirements**

 See previous [Design Requirements](#).

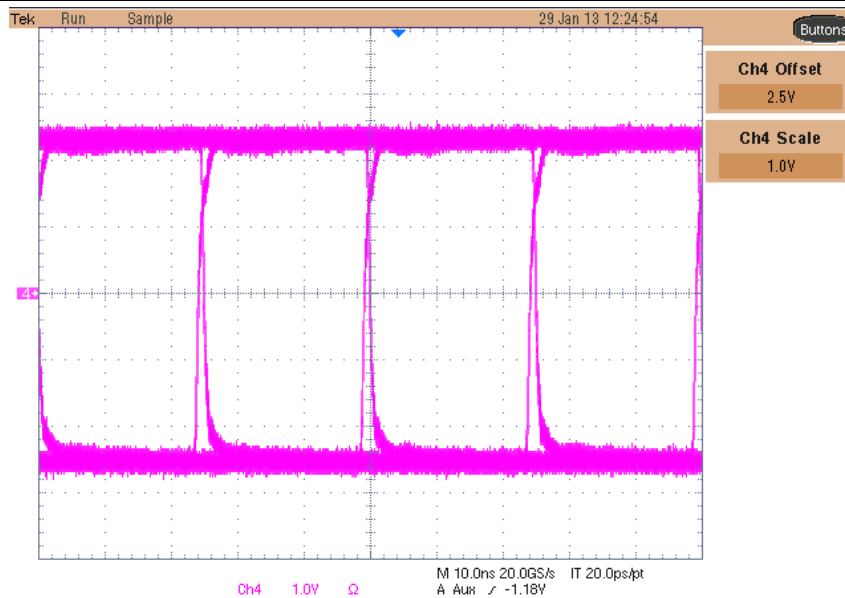
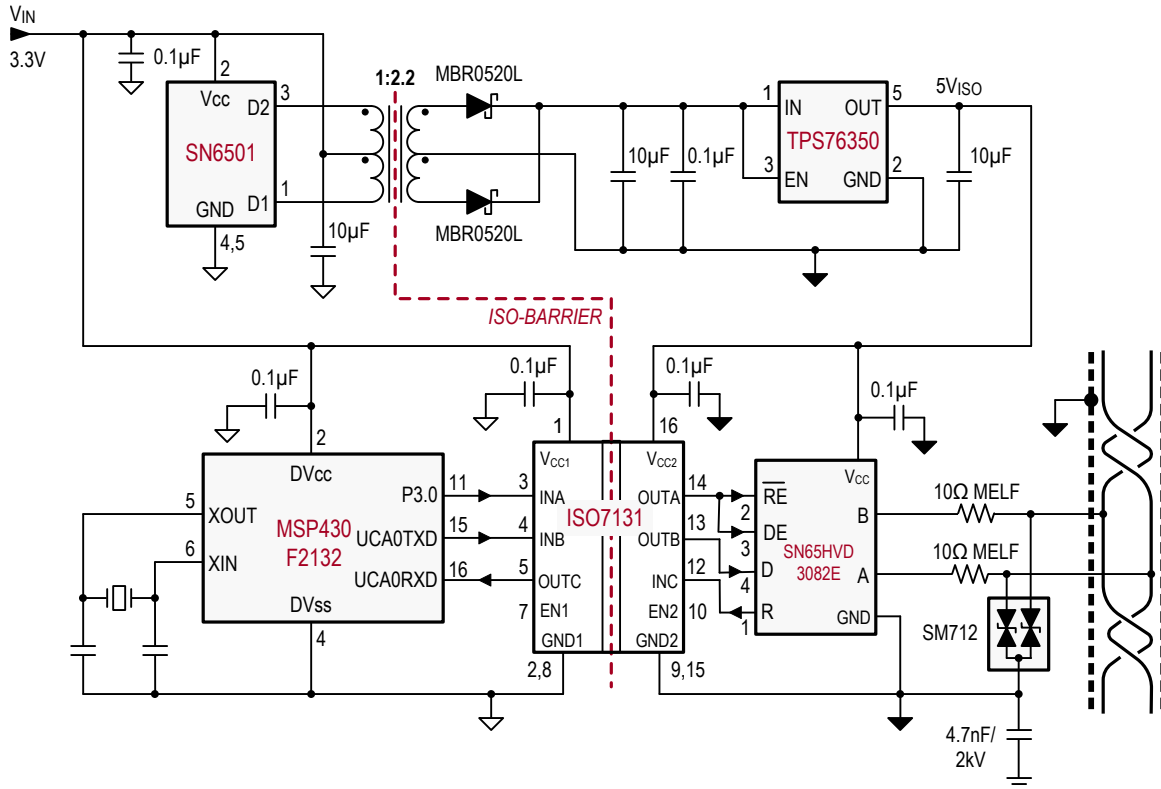
**9.2.2.2 Detailed Design Procedure**

 See previous [Detailed Design Procedure](#).

**9.2.2.3 Application Curves**

 See previous [Application Curves](#).

## 10 Power Supply Recommendations

To ensure reliable operation at all data rates and supply voltages, a 0.1- $\mu$ F bypass capacitor is recommended at input and output supply pins ( $V_{CC1}$  and  $V_{CC2}$ ). The capacitors should be placed as close to the supply pins as possible. If only a single primary-side power supply is available in an application, isolated power can be generated for the secondary-side with the help of a transformer driver such as TI's [SN6501](#). For such applications, detailed power supply design and transformer selection recommendations are available in [SN6501](#) data sheet ([SLLSEA0](#)).

## 11 Layout

### 11.1 Layout Guidelines

A minimum of four layers is required to accomplish a low EMI PCB design (see [图 25](#)). Layer stacking should be in the following order (top-to-bottom): high-speed signal layer, ground plane, power plane and low-frequency signal layer.

- Routing the high-speed traces on the top layer avoids the use of vias (and the introduction of their inductances) and allows for clean interconnects between the isolator and the transmitter and receiver circuits of the data link.
- Placing a solid ground plane next to the high-speed signal layer establishes controlled impedance for transmission line interconnects and provides an excellent low-inductance path for the return current flow.
- Placing the power plane next to the ground plane creates additional high-frequency bypass capacitance of approximately 100pF/in<sup>2</sup>.
- Routing the slower speed control signals on the bottom layer allows for greater flexibility as these signal links usually have margin to tolerate discontinuities such as vias.

If an additional supply voltage plane or signal layer is needed, add a second power / ground plane system to the stack to keep it symmetrical. This makes the stack mechanically stable and prevents it from warping. Also the power and ground plane of each power system can be placed closer together, thus increasing the high-frequency bypass capacitance significantly.

For detailed layout recommendations, see Application Note [SLLA284](#), *Digital Isolator Design Guide*.

#### 11.1.1 PCB Material

For digital circuit boards operating below 150 Mbps, (or rise and fall times higher than 1 ns), and trace lengths of up to 10 inches, use standard FR-4 epoxy-glass as PCB material. FR-4 (Flame Retardant 4) meets the requirements of Underwriters Laboratories UL94-V0, and is preferred over cheaper alternatives due to its lower dielectric losses at high frequencies, less moisture absorption, greater strength and stiffness, and its self-extinguishing flammability-characteristics.

#### 11.2 Layout Example

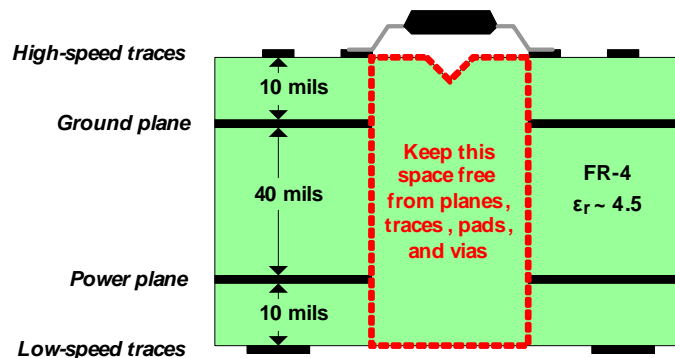

**图 25. Recommended Layer Stack**

## 12 器件和文档支持

### 12.1 文档支持

#### 12.1.1 相关文档

- [SLLA284](#), 《数字隔离器设计指南》
- [SLLSEA0](#), 《用于隔离电源的变压器驱动器》

### 12.2 相关链接

以下表格列出了快速访问链接。范围包括技术文档、支持与社区资源、工具和软件，并且可以快速访问样片或购买链接。

表 4. 相关链接

器件	产品文件夹	样片与购买	技术文档	工具与软件	支持与社区
ISO7131CC	<a href="#">请单击此处</a>	<a href="#">请单击此处</a>	<a href="#">请单击此处</a>	<a href="#">请单击此处</a>	<a href="#">请单击此处</a>
ISO7140CC	<a href="#">请单击此处</a>	<a href="#">请单击此处</a>	<a href="#">请单击此处</a>	<a href="#">请单击此处</a>	<a href="#">请单击此处</a>
ISO7140FCC	<a href="#">请单击此处</a>	<a href="#">请单击此处</a>	<a href="#">请单击此处</a>	<a href="#">请单击此处</a>	<a href="#">请单击此处</a>
ISO7141CC	<a href="#">请单击此处</a>	<a href="#">请单击此处</a>	<a href="#">请单击此处</a>	<a href="#">请单击此处</a>	<a href="#">请单击此处</a>
ISO7141FCC	<a href="#">请单击此处</a>	<a href="#">请单击此处</a>	<a href="#">请单击此处</a>	<a href="#">请单击此处</a>	<a href="#">请单击此处</a>

### 12.3 商标

Modbus is a trademark of Gould Inc.

All other trademarks are the property of their respective owners.

### 12.4 静电放电警告



这些装置包含有限的内置 ESD 保护。存储或装卸时，应将导线一起截短或将装置放置于导电泡棉中，以防止 MOS 门极遭受静电损伤。

### 12.5 术语表

[SLYZ022](#) — *TI* 术语表。

这份术语表列出并解释术语、首字母缩略词和定义。

[SLLA353](#) - 《隔离相关术语》。

## 13 机械封装和可订购信息

以下页中包括机械封装和可订购信息。 这些信息是针对指定器件可提供的最新数据。 这些数据会在无通知且不对本文档进行修订的情况下发生改变。 欲获得该数据表的浏览器版本，请查阅左侧的导航栏。

**PACKAGING INFORMATION**

Orderable Device	Status (1)	Package Type	Package Drawing	Pins	Package Qty	Eco Plan (2)	Lead finish/ Ball material (6)	MSL Peak Temp (3)	Op Temp (°C)	Device Marking (4/5)	Samples
ISO7131CCDBQ	ACTIVE	SSOP	DBQ	16	75	RoHS & Green	NIPDAU	Level-2-260C-1 YEAR	-40 to 125	7131CC	<a href="#">Samples</a>
ISO7131CCDBQR	ACTIVE	SSOP	DBQ	16	2500	RoHS & Green	NIPDAU	Level-2-260C-1 YEAR	-40 to 125	7131CC	<a href="#">Samples</a>
ISO7140CCDBQ	ACTIVE	SSOP	DBQ	16	75	RoHS & Green	NIPDAU	Level-2-260C-1 YEAR	-40 to 125	7140CC	<a href="#">Samples</a>
ISO7140CCDBQR	ACTIVE	SSOP	DBQ	16	2500	RoHS & Green	NIPDAU	Level-2-260C-1 YEAR	-40 to 125	7140CC	<a href="#">Samples</a>
ISO7140FCCDBQ	ACTIVE	SSOP	DBQ	16	75	RoHS & Green	NIPDAU	Level-2-260C-1 YEAR	-40 to 125	7140FC	<a href="#">Samples</a>
ISO7140FCCDBQR	ACTIVE	SSOP	DBQ	16	2500	RoHS & Green	NIPDAU	Level-2-260C-1 YEAR	-40 to 125	7140FC	<a href="#">Samples</a>
ISO7141CCDBQ	ACTIVE	SSOP	DBQ	16	75	RoHS & Green	NIPDAU	Level-2-260C-1 YEAR	-40 to 125	7141CC	<a href="#">Samples</a>
ISO7141CCDBQR	ACTIVE	SSOP	DBQ	16	2500	RoHS & Green	NIPDAU	Level-2-260C-1 YEAR	-40 to 125	7141CC	<a href="#">Samples</a>
ISO7141FCCDBQ	ACTIVE	SSOP	DBQ	16	75	RoHS & Green	NIPDAU	Level-2-260C-1 YEAR	-40 to 125	7141FC	<a href="#">Samples</a>
ISO7141FCCDBQR	ACTIVE	SSOP	DBQ	16	2500	RoHS & Green	NIPDAU	Level-2-260C-1 YEAR	-40 to 125	7141FC	<a href="#">Samples</a>

(1) The marketing status values are defined as follows:

**ACTIVE:** Product device recommended for new designs.

**LIFEBUY:** TI has announced that the device will be discontinued, and a lifetime-buy period is in effect.

**NRND:** Not recommended for new designs. Device is in production to support existing customers, but TI does not recommend using this part in a new design.

**PREVIEW:** Device has been announced but is not in production. Samples may or may not be available.

**OBSOLETE:** TI has discontinued the production of the device.

(2) **RoHS:** TI defines "RoHS" to mean semiconductor products that are compliant with the current EU RoHS requirements for all 10 RoHS substances, including the requirement that RoHS substance do not exceed 0.1% by weight in homogeneous materials. Where designed to be soldered at high temperatures, "RoHS" products are suitable for use in specified lead-free processes. TI may reference these types of products as "Pb-Free".

**RoHS Exempt:** TI defines "RoHS Exempt" to mean products that contain lead but are compliant with EU RoHS pursuant to a specific EU RoHS exemption.

**Green:** TI defines "Green" to mean the content of Chlorine (Cl) and Bromine (Br) based flame retardants meet JS709B low halogen requirements of <=1000ppm threshold. Antimony trioxide based flame retardants must also meet the <=1000ppm threshold requirement.

(3) MSL, Peak Temp. - The Moisture Sensitivity Level rating according to the JEDEC industry standard classifications, and peak solder temperature.

(4) There may be additional marking, which relates to the logo, the lot trace code information, or the environmental category on the device.

<sup>(5)</sup> Multiple Device Markings will be inside parentheses. Only one Device Marking contained in parentheses and separated by a "~" will appear on a device. If a line is indented then it is a continuation of the previous line and the two combined represent the entire Device Marking for that device.

<sup>(6)</sup> Lead finish/Ball material - Orderable Devices may have multiple material finish options. Finish options are separated by a vertical ruled line. Lead finish/Ball material values may wrap to two lines if the finish value exceeds the maximum column width.

**Important Information and Disclaimer:** The information provided on this page represents TI's knowledge and belief as of the date that it is provided. TI bases its knowledge and belief on information provided by third parties, and makes no representation or warranty as to the accuracy of such information. Efforts are underway to better integrate information from third parties. TI has taken and continues to take reasonable steps to provide representative and accurate information but may not have conducted destructive testing or chemical analysis on incoming materials and chemicals. TI and TI suppliers consider certain information to be proprietary, and thus CAS numbers and other limited information may not be available for release.

In no event shall TI's liability arising out of such information exceed the total purchase price of the TI part(s) at issue in this document sold by TI to Customer on an annual basis.

**TAPE AND REEL INFORMATION**

**QUADRANT ASSIGNMENTS FOR PIN 1 ORIENTATION IN TAPE**



\*All dimensions are nominal

Device	Package Type	Package Drawing	Pins	SPQ	Reel Diameter (mm)	Reel Width W1 (mm)	A0 (mm)	B0 (mm)	K0 (mm)	P1 (mm)	W (mm)	Pin1 Quadrant
ISO7131CCDBQR	SSOP	DBQ	16	2500	330.0	12.4	6.4	5.2	2.1	8.0	12.0	Q1
ISO7140CCDBQR	SSOP	DBQ	16	2500	330.0	12.4	6.4	5.2	2.1	8.0	12.0	Q1
ISO7140FCCDBQR	SSOP	DBQ	16	2500	330.0	12.4	6.4	5.2	2.1	8.0	12.0	Q1
ISO7141CCDBQR	SSOP	DBQ	16	2500	330.0	12.4	6.4	5.2	2.1	8.0	12.0	Q1
ISO7141FCCDBQR	SSOP	DBQ	16	2500	330.0	12.4	6.4	5.2	2.1	8.0	12.0	Q1

**TAPE AND REEL BOX DIMENSIONS**

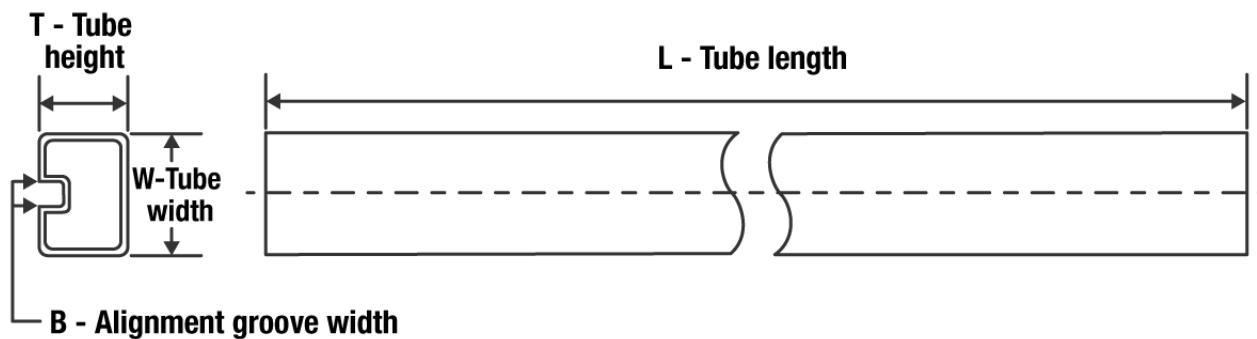

\*All dimensions are nominal

Device	Package Type	Package Drawing	Pins	SPQ	Length (mm)	Width (mm)	Height (mm)
ISO7131CCDBQR	SSOP	DBQ	16	2500	350.0	350.0	43.0
ISO7140CCDBQR	SSOP	DBQ	16	2500	350.0	350.0	43.0
ISO7140FCCDBQR	SSOP	DBQ	16	2500	350.0	350.0	43.0
ISO7141CCDBQR	SSOP	DBQ	16	2500	350.0	350.0	43.0
ISO7141FCCDBQR	SSOP	DBQ	16	2500	350.0	350.0	43.0

**TUBE**

\*All dimensions are nominal

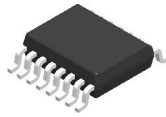
Device	Package Name	Package Type	Pins	SPQ	L (mm)	W (mm)	T (μm)	B (mm)
ISO7131CCDBQ	DBQ	SSOP	16	75	505.46	6.76	3810	4
ISO7140CCDBQ	DBQ	SSOP	16	75	505.46	6.76	3810	4
ISO7140FCCDBQ	DBQ	SSOP	16	75	505.46	6.76	3810	4
ISO7141CCDBQ	DBQ	SSOP	16	75	505.46	6.76	3810	4
ISO7141FCCDBQ	DBQ	SSOP	16	75	505.46	6.76	3810	4



# DBQ0016A

# PACKAGE OUTLINE

## SSOP - 1.75 mm max height

SHRINK SMALL-OUTLINE PACKAGE

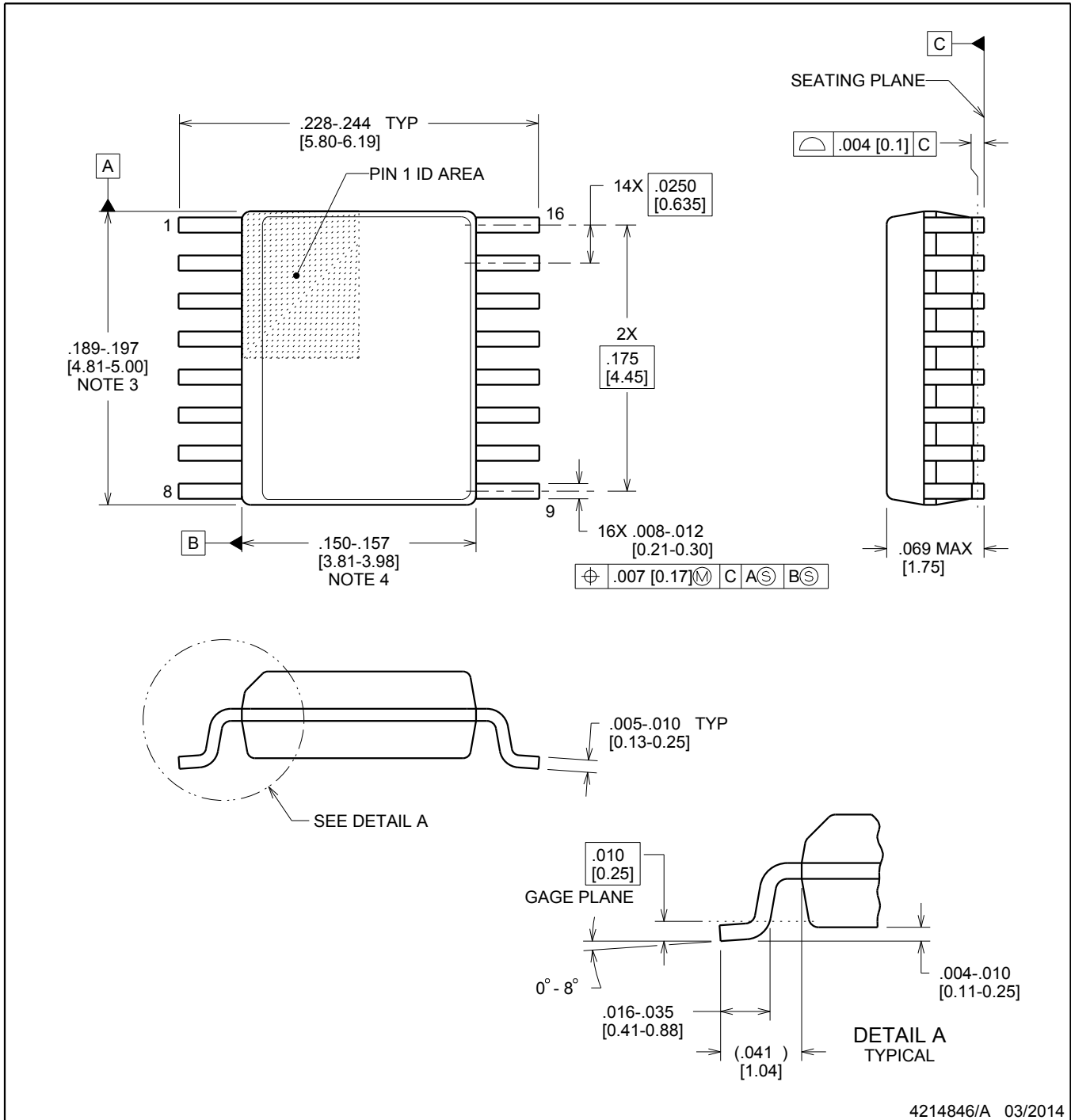

4214846/A 03/2014

### NOTES:

- Linear dimensions are in inches [millimeters]. Dimensions in parenthesis are for reference only. Controlling dimensions are in inches. Dimensioning and tolerancing per ASME Y14.5M.
- This drawing is subject to change without notice.
- This dimension does not include mold flash, protrusions, or gate burrs. Mold flash, protrusions, or gate burrs shall not exceed .006 inch, per side.
- This dimension does not include interlead flash.
- Reference JEDEC registration MO-137, variation AB.

# EXAMPLE BOARD LAYOUT

DBQ0016A

SSOP - 1.75 mm max height

SHRINK SMALL-OUTLINE PACKAGE

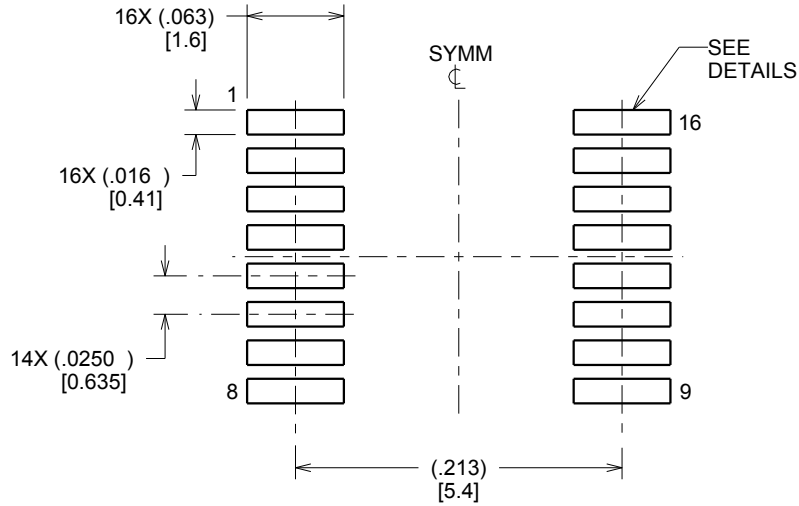

LAND PATTERN EXAMPLE  
SCALE:8X

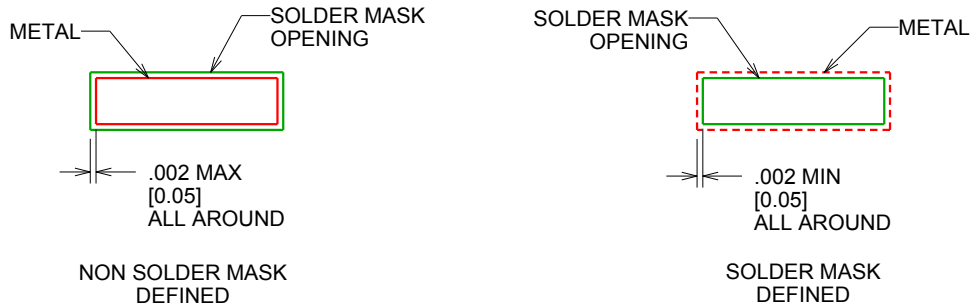

SOLDER MASK DETAILS

4214846/A 03/2014

NOTES: (continued)

- 6. Publication IPC-7351 may have alternate designs.
- 7. Solder mask tolerances between and around signal pads can vary based on board fabrication site.

# EXAMPLE STENCIL DESIGN

DBQ0016A

SSOP - 1.75 mm max height

SHRINK SMALL-OUTLINE PACKAGE

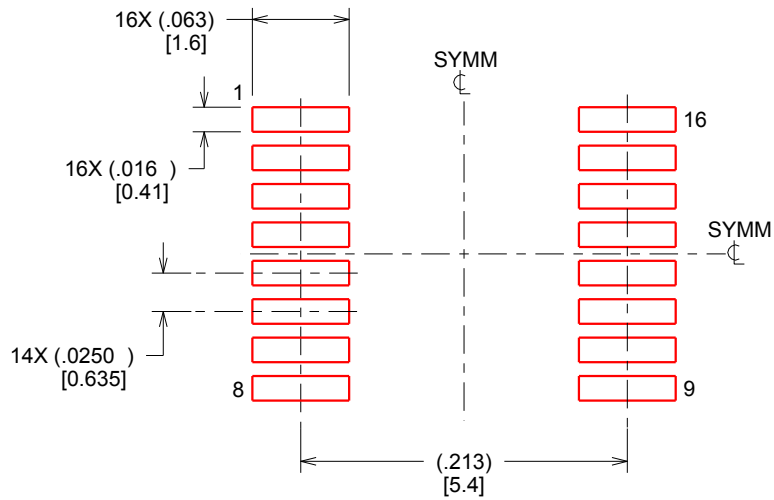

SOLDER PASTE EXAMPLE  
BASED ON .005 INCH [0.127 MM] THICK STENCIL  
SCALE:8X

4214846/A 03/2014

NOTES: (continued)

8. Laser cutting apertures with trapezoidal walls and rounded corners may offer better paste release. IPC-7525 may have alternate design recommendations.
9. Board assembly site may have different recommendations for stencil design.

## 重要声明和免责声明

TI“按原样”提供技术和可靠性数据（包括数据表）、设计资源（包括参考设计）、应用或其他设计建议、网络工具、安全信息和其他资源，不保证没有瑕疵且不做任何明示或暗示的担保，包括但不限于对适销性、某特定用途方面的适用性或不侵犯任何第三方知识产权的暗示担保。

这些资源可供使用 TI 产品进行设计的熟练开发人员使用。您将自行承担以下全部责任：(1) 针对您的应用选择合适的 TI 产品，(2) 设计、验证并测试您的应用，(3) 确保您的应用满足相应标准以及任何其他功能安全、信息安全、监管或其他要求。

这些资源如有变更，恕不另行通知。TI 授权您仅可将这些资源用于研发本资源所述的 TI 产品的应用。严禁对这些资源进行其他复制或展示。您无权使用任何其他 TI 知识产权或任何第三方知识产权。您应全额赔偿因在这些资源的使用中对 TI 及其代表造成的任何索赔、损害、成本、损失和债务，TI 对此概不负责。

TI 提供的产品受 [TI 的销售条款](#) 或 [ti.com](#) 上其他适用条款/TI 产品随附的其他适用条款的约束。TI 提供这些资源并不会扩展或以其他方式更改 TI 针对 TI 产品发布的适用的担保或担保免责声明。

TI 反对并拒绝您可能提出的任何其他或不同的条款。

邮寄地址：Texas Instruments, Post Office Box 655303, Dallas, Texas 75265

Copyright © 2022，德州仪器 (TI) 公司