

SN74LVC1G139 2 线至 4 线解码器

1 特性

- 采用德州仪器 (TI) NanoStar™和 NanoFree™封装
- 支持 5V V_{CC} 运行
- 输入电压高达 5.5V
- 支持下行转换到 V_{CC}
- 3.3V 和 15pF 负载条件下 t_{pd} 最大值为 4.9ns
- 低功耗, I_{CC} 最大值为 10 μ A
- 电压为 3.3V 时, 输出驱动为 ± 24 mA
- I_{off} 支持带电插入、局部关断模式以及后驱动保护
- 闩锁性能超过 100mA, 符合 JESD 78 II 类规范
- ESD 保护性能超出 JESD 22 标准
 - 2000V 人体放电模型 (A114-A)
 - 200V 机器模型 (A115-A)
 - 1000V 充电器件模型 (C101)

2 应用

- AV 接收机
- 固态硬盘 (SSD): 客户端和企业级
- 电视: LCD、数字和高清 (HD)
- 平板电脑: 企业级
- 视频分析: 服务器

3 说明

此 SN74LVC1G139 2 线至 4 线解码器专为 1.65V 至 5.5V V_{CC} 工作电压而设计。

SN74LVC1G139 2 线至 4 线解码器可适用于需要极短传播延迟时间的高性能存储解码或数据路由应用。在高性能存储系统中, 可使用此解码器来最大限度地消除系统解码的影响。与使用高速使能电路的高速存储器一起使用时, 这些解码器的延迟时间和存储器的使能时间通常小于存储器的典型存取时间。这意味着解码器引起的有效系统延迟可以忽略不计。

NanoStar 和 NanoFree 封装技术是器件封装概念的一项重大突破, 它将硅晶片用作封装。

该器件完全适用于使用 I_{off} 的局部掉电应用。 I_{off} 电路会禁用输出, 从而在器件掉电时防止电流回流损坏器件。

设备信息⁽¹⁾

器件型号	封装	外观尺寸 (NOM)
SN74LVC1G139DCT	SM8 (8)	2.95mm x 2.80mm
SN74LVC1G139DCU	超薄小外形尺寸封装 (VSSOP)(8)	2.30mm x 2.00mm
SN74LVC1G139YZP	DSBGA (8)	1.91mm x 0.91mm

(1) 如需了解所有可用封装, 请参阅数据表末尾的可订购产品附录。

简化原理图

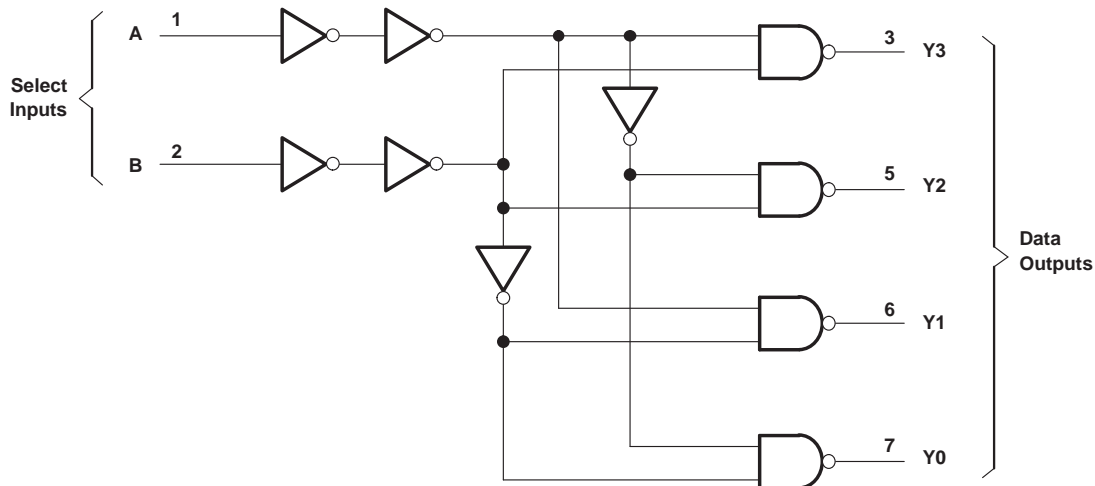

目录

<p>1 特性 1</p> <p>2 应用 1</p> <p>3 说明 1</p> <p>4 修订历史记录 2</p> <p>5 Pin Configuration and Functions 3</p> <p>6 Specification 4</p> <p> 6.1 Absolute Maximum Ratings 4</p> <p> 6.2 ESD Ratings 4</p> <p> 6.3 Recommended Operating Conditions 5</p> <p> 6.4 Thermal Information 5</p> <p> 6.5 Electrical Characteristics 6</p> <p> 6.6 Switching Characteristics 6</p> <p> 6.7 Operating Characteristics 6</p> <p>7 Typical Characteristics 7</p> <p>8 Parameter Measurement Information 8</p> <p>9 Detailed Description 10</p> <p> 9.1 Overview 10</p>	<p> 9.2 Functional Block Diagram 10</p> <p> 9.3 Feature Description 10</p> <p> 9.4 Device Functional Modes 10</p> <p>10 Application and Implementation 11</p> <p> 10.1 Application Information 11</p> <p> 10.2 Typical Application 11</p> <p>11 Power Supply Recommendations 12</p> <p>12 Layout 12</p> <p> 12.1 Layout Guidelines 12</p> <p> 12.2 Layout Example 12</p> <p>13 器件和文档支持 13</p> <p> 13.1 文档支持 13</p> <p> 13.2 社区资源 13</p> <p> 13.3 商标 13</p> <p> 13.4 静电放电警告 13</p> <p> 13.5 Glossary 13</p> <p>14 机械、封装和可订购信息 13</p>
--	--

4 修订历史记录

注：之前版本的页码可能与当前版本有所不同。

Changes from Revision D (February 2014) to Revision E	Page
---	------

- | | |
|---|---|
| • Updated the YZP package drawing | 3 |
|---|---|

Changes from Revision C (December 2005) to Revision D	Page
---	------

- | | |
|---|---|
| • 添加了应用部分、器件信息表、ESD 额定值表、热性能信息表、典型特性部分、特性说明部分、器件功能模式、应用和实施部分、电源相关建议部分、布局部分、器件和文档支持部分以及机械、封装和可订购信息部分 | 1 |
|---|---|

Changes from Revision B (December 2005) to Revision C	Page
---	------

- | | |
|----------------------------|---|
| • 将文档更新为新的 TI 数据表格式。 | 1 |
| • 已更新特性部分) 。 | 1 |
| • 删除了订购信息表。 | 1 |

5 Pin Configuration and Functions

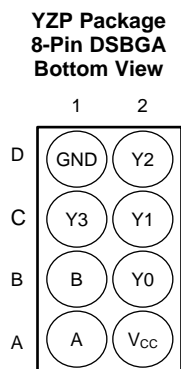
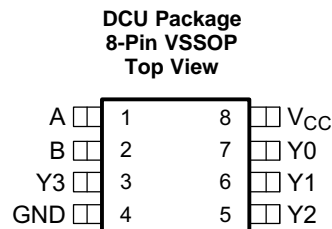
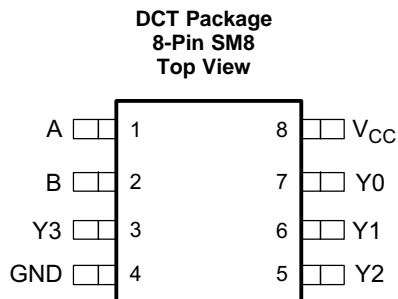

Pin Functions

NAME	PIN		I/O	DESCRIPTION
	DCT, DCU	YZP		
A	1	A1	I	Adress input, bit 0
B	2	B1	I	Adress input, bit 1
Y ₃	3	C1	O	Output 3, low when B is high and A is high
GND	4	D1	—	Ground
Y ₂	5	D2	O	Output 2, low when B is high and A is low
Y ₁	6	C2	O	Output 1, low when B is low and A is high
Y ₀	7	B2	O	Output 0, low when B is low and A is low
V _{CC}	8	A2	—	Power pin

6 Specification

6.1 Absolute Maximum Ratings

 over operating free-air temperature range (unless otherwise noted)⁽¹⁾

		MIN	MAX	UNIT
Supply Voltage, V_{CC}		-0.5	6.5	V
Input Voltage, V_I		-0.5	6.5	V
Voltage applied to any output in the high-impedance or power-off state, V_O ⁽²⁾		-0.5	6.5	V
Voltage applied to any output in the high or low state, V_O ⁽²⁾⁽³⁾		-0.5	$V_{CC} + 0.5$	V
Input clamp current, I_{IK}	$V_I < 0$		-50	mA
Output clamp current, I_{OK}	$V_O < 0$		-50	mA
Continuous output current, I_O			±50	mA
Continuous current through V_{CC} or GND, I_{CC}			±100	mA
Junction temperature, T_J			150	°C
Storage temperature, T_{stg}		-65	150	°C

- (1) Stresses beyond those listed under *Absolute Maximum Ratings* may cause permanent damage to the device. These are stress ratings only, and functional operation of the device at these or any other conditions beyond those indicated under *Recommended Operating Conditions* is not implied. Exposure to absolute-maximum-rated conditions for extended periods may affect device reliability.
- (2) The input and output negative-voltage ratings may be exceeded if the input and output current ratings are observed.
- (3) The value of V_{CC} is provided in the *Recommended Operating Conditions* table.

6.2 ESD Ratings

		VALUE	UNIT
$V_{(ESD)}$ Electrostatic discharge	Human body model (HBM), per ANSI/ESDA/JEDEC JS-001 ⁽¹⁾	±2500	V
	Charged-device model (CDM), per JEDEC specification JESD22-C101 ⁽²⁾	±1500	
	Machine model	±200	

- (1) JEDEC document JEP155 states that 500-V HBM allows safe manufacturing with a standard ESD control process.
- (2) JEDEC document JEP157 states that 250-V CDM allows safe manufacturing with a standard ESD control process.

6.3 Recommended Operating Conditions

over operating free-air temperature range (unless otherwise noted)⁽¹⁾

		MIN	MAX	UNIT	
V _{CC}	Supply voltage	Operating	1.65	5.5	V
		Data retention only	1.5		
V _{IH}	High-level input voltage	V _{CC} = 1.65 V to 1.95 V	0.65 × V _{CC}		V
		V _{CC} = 2.3 V to 2.7 V	1.7		
		V _{CC} = 3 V to 3.6 V	2		
		V _{CC} = 4.5 V to 5.5 V	0.7 × V _{CC}		
V _{IL}	Low-level input voltage	V _{CC} = 1.65 V to 1.95 V		0.35 × V _{CC}	V
		V _{CC} = 2.3 V to 2.7 V		0.7	
		V _{CC} = 3 V to 3.6 V		0.8	
		V _{CC} = 4.5 V to 5.5 V		0.3 × V _{CC}	
V _I	Input voltage	0	5.5	V	
V _O	Output voltage	0	V _{CC}	V	
I _{OH}	High-level output current	V _{CC} = 1.65 V		–4	mA
		V _{CC} = 2.3 V		–8	
		V _{CC} = 3 V		–16	
				–24	
V _{CC} = 4.5 V		–32			
I _{OL}	Low-level output current	V _{CC} = 1.65 V		4	mA
		V _{CC} = 2.3 V		8	
		V _{CC} = 3 V		16	
				24	
V _{CC} = 4.5 V		32			
Δt/Δv	Input transition rise or fall rate	V _{CC} = 1.8 V ± 0.15 V, 2.5 V ± 0.2 V		20	ns/V
		V _{CC} = 3.3 V ± 0.3 V		15	
		V _{CC} = 5 V ± 0.5 V		10	
T _A	Operating free-air temperature	–40	85	°C	

(1) All unused inputs of the device must be held at V_{CC} or GND to ensure proper device operation. See the [Implications of Slow or Floating CMOS Inputs application report](#).

6.4 Thermal Information

THERMAL METRIC ⁽¹⁾	SN74LVC1G139			UNIT	
	DCT (SM8)	DCU (VSSOP)	YZP (DSBGA)		
	8 PINS	8 PINS	8 PINS		
R _{θJA}	Junction-to-ambient thermal resistance	194	195	106	°C/W
R _{θJC(top)}	Junction-to-case (top) thermal resistance	124	74	1.6	°C/W
R _{θJB}	Junction-to-board thermal resistance	106	74	11	°C/W
ψ _{JT}	Junction-to-top characterization parameter	48	6.7	3.1	°C/W
ψ _{JB}	Junction-to-board characterization parameter	105	73	11	°C/W
R _{θJC(bot)}	Junction-to-case (bottom) thermal resistance	—	—	—	°C/W

(1) For more information about traditional and new thermal metrics, see the [Semiconductor and IC Package Thermal Metrics application report](#).

6.5 Electrical Characteristics

over recommended operating free-air temperature range (unless otherwise noted)

PARAMETER	TEST CONDITIONS		MIN	TYP ⁽¹⁾	MAX	UNIT
V _{OH} High-level output voltage	I _{OH} = -100 μA, V _{CC} = 1.65 V to 5.5 V		V _{CC} - 0.1			V
	I _{OH} = -4 mA, V _{CC} = 1.65 V		1.2			
	I _{OH} = -8 mA, V _{CC} = 2.3 V		1.9			
	I _{OH} = -16 mA, V _{CC} = 3 V		2.4			
	I _{OH} = -24 mA, V _{CC} = 3 V		2.3			
	I _{OH} = -32 mA, V _{CC} = 4.5 V		3.8			
V _{OL} Low-level output voltage	I _{OL} = 100 μA, V _{CC} = 1.65 V to 5.5 V		0.1			V
	I _{OL} = 4 mA, V _{CC} = 1.65 V		0.45			
	I _{OL} = 8 mA, V _{CC} = 2.3 V		0.3			
	I _{OL} = 16 mA, V _{CC} = 3 V		0.4			
	I _{OL} = 24 mA, V _{CC} = 3 V		0.55			
	I _{OL} = 32 mA, V _{CC} = 4.5 V		0.55			
I _I Inflection-point current	A or B inputs: V _I = 5.5 V or GND, V _{CC} = 0 to 5.5 V		±1			μA
I _{off} Off-state current	V _I or V _O = 5.5 V, V _{CC} = 0		±5			μA
I _{CC} Supply current	V _I = 5.5 V or GND, I _O = 0, V _{CC} = 1.65 V to 5.5 V		10			μA
ΔI _{CC} Supply current change	One input at V _{CC} - 0.6 V, other inputs at V _{CC} or GND, V _{CC} = 3 V to 5.5 V		500			μA
C _i Input capacitance	V _I = V _{CC} or GND, V _{CC} = 3.3 V		4			pF

 (1) All typical values are at V_{CC} = 3.3 V, T_A = 25°C.

6.6 Switching Characteristics

 over recommended operating free-air temperature range, C_L = 15 pF (unless otherwise noted)

PARAMETER	TEST CONDITIONS		MIN	MAX	UNIT	
t _{pd} Propagation delay time	A or B-to-Y	See 表 2	V _{CC} = 1.8 V ± 0.15 V	2.7	15.3	ns
			V _{CC} = 2.5 V ± 0.2 V	1.5	7.5	
			V _{CC} = 3.3 V ± 0.3 V	0.9	4.9	
			V _{CC} = 5 V ± 0.5 V	0.8	3.6	
		See 表 3	V _{CC} = 1.8 V ± 0.15 V	3	16.7	
			V _{CC} = 2.5 V ± 0.2 V	1.6	8.2	
			V _{CC} = 3.3 V ± 0.3 V	1.2	5.9	
			V _{CC} = 5 V ± 0.5 V	1.1	4.2	

6.7 Operating Characteristics

 T_A = 25°C

PARAMETER	TEST CONDITIONS		MIN	TYP	MAX	UNIT
C _{pd} ⁽¹⁾ Power dissipation capacitance	f = 10 MHz	V _{CC} = 1.8 V	31			pF
		V _{CC} = 2.5 V	34			
		V _{CC} = 3.3 V	36			
		V _{CC} = 5 V	39			

(1) Two outputs switching.

7 Typical Characteristics

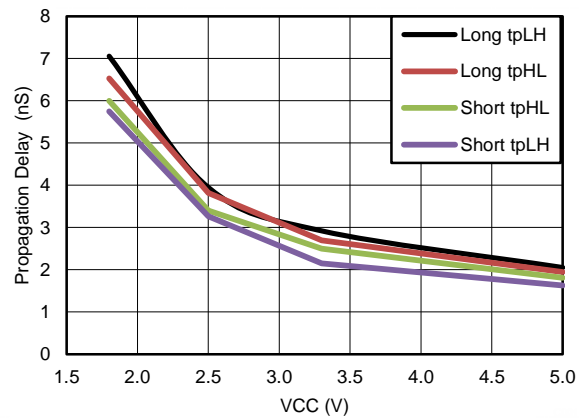

(1) Short is 2 inverter path. Long is 3 inverter path.

图 1. Propagation Delay vs VCC

8 Parameter Measurement Information

Unless otherwise noted, all input pulses are supplied by generators that have the following characteristics:

- PRR \leq 10 MHz
- $Z_O = 50 \Omega$

注

All parameters and waveforms are not applicable to all devices.

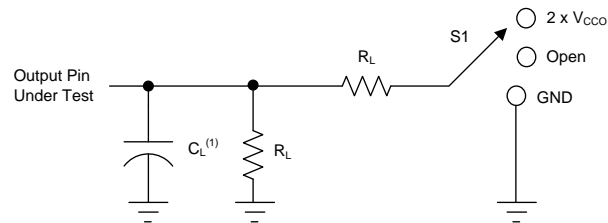

(1) C_L includes probe and jig capacitance.

图 2. Load Circuit

表 1. Loading Conditions for Parameter

TEST	S1
$t_{PLH}^{(1)}$, $t_{PHL}^{(1)}$	Open
$t_{PLZ}^{(2)}$, $t_{PZL}^{(3)}$	V_{LOAD}
$t_{PHZ}^{(2)}$, $t_{PZH}^{(3)}$	GND

- (1) t_{PLH} and t_{PHL} are the same as t_{pd} .
 (2) t_{PLZ} and t_{PHZ} are the same as t_{dis} .
 (3) t_{PZL} and t_{PZH} are the same as t_{en} .

表 2. Loading Conditions for V_{CC} – Case 1

V_{CC}	INPUTS		V_M	V_{LOAD}	C_L	R_L	V_A
	V_I	t_r/t_f					
$1.8 V \pm 0.15 V$	V_{CC}	$\leq 2 \text{ ns}$	$V_{CC} / 2$	$2 \times V_{CC}$	15 pF	1 M Ω	0.15 V
$2.5 V \pm 0.2 V$	V_{CC}	$\leq 2 \text{ ns}$	$V_{CC} / 2$	$2 \times V_{CC}$	15 pF	1 M Ω	0.15 V
$3.3 V \pm 0.3 V$	3 V	$\leq 2.5 \text{ ns}$	1.5 V	6 V	15 pF	1 M Ω	0.3 V
$5 V \pm 0.5 V$	V_{CC}	$\leq 2.5 \text{ ns}$	$V_{CC} / 2$	$2 \times V_{CC}$	15 pF	1 M Ω	0.3 V

表 3. Loading Conditions for V_{CC} – Case 2

V_{CC}	INPUTS		V_M	V_{LOAD}	C_L	R_L	V_A
	V_I	t_r/t_f					
$1.8 V \pm 0.15 V$	V_{CC}	$\leq 2 \text{ ns}$	$V_{CC} / 2$	$2 \times V_{CC}$	30 pF	1 M Ω	0.15 V
$2.5 V \pm 0.2 V$	V_{CC}	$\leq 2 \text{ ns}$	$V_{CC} / 2$	$2 \times V_{CC}$	30 pF	500 M Ω	0.15 V
$3.3 V \pm 0.3 V$	3 V	$\leq 2.5 \text{ ns}$	1.5 V	6 V	30 pF	500 M Ω	0.3 V
$5 V \pm 0.5 V$	V_{CC}	$\leq 2.5 \text{ ns}$	$V_{CC} / 2$	$2 \times V_{CC}$	30 pF	500 M Ω	0.3 V



图 3. Voltage Waveforms: Pulse Duration



(1) The outputs are measured one at a time, with one transition per measurement.

图 4. Voltage Waveforms: Propagation Delay Times Inverting And Noninverting Outputs

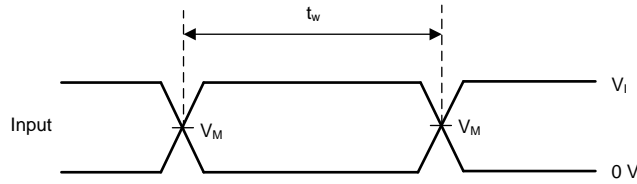
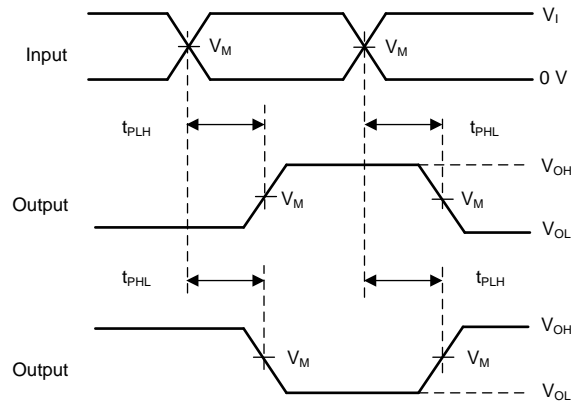

图 5. Voltage Waveforms: Setup and Hold Times



- (1) Waveform 1 is for an output with internal conditions such that the output is low, except when disabled by the output control.
- (2) Waveform 2 is for an output with internal conditions such that the output is high, except when disabled by the output control.
- (3) The outputs are measured one at a time, with one transition per measurement.

图 6. Voltage Waveforms: Enable and Disable Times, Low- and High-Level Enabling

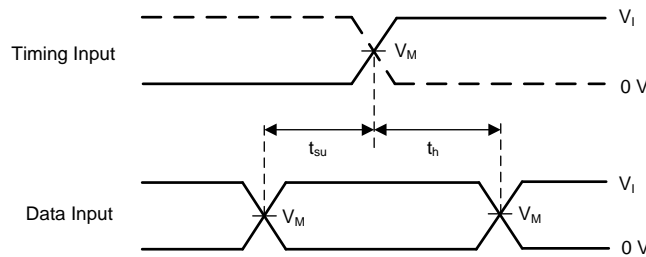
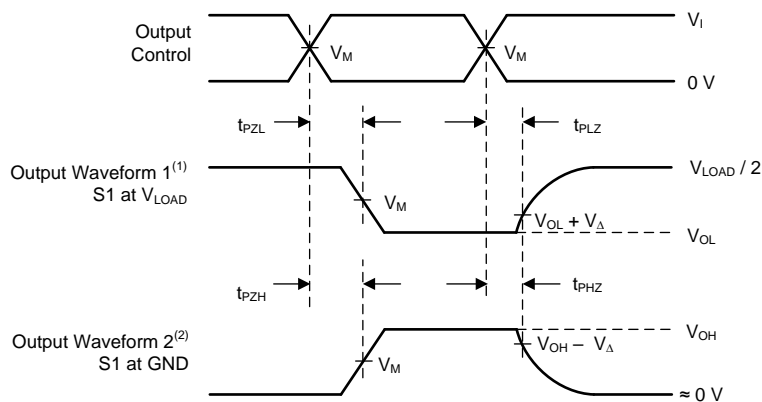
9 Detailed Description

9.1 Overview

The LVC1G139 device decodes the 2-bit input to one of the four outputs. The B input is the most significant bit and the Y outputs are active low. The propagation delays are very short and well matched (see [图 1](#)). Supply voltage from 1.65-V to 5.5-V is supported.

9.2 Functional Block Diagram

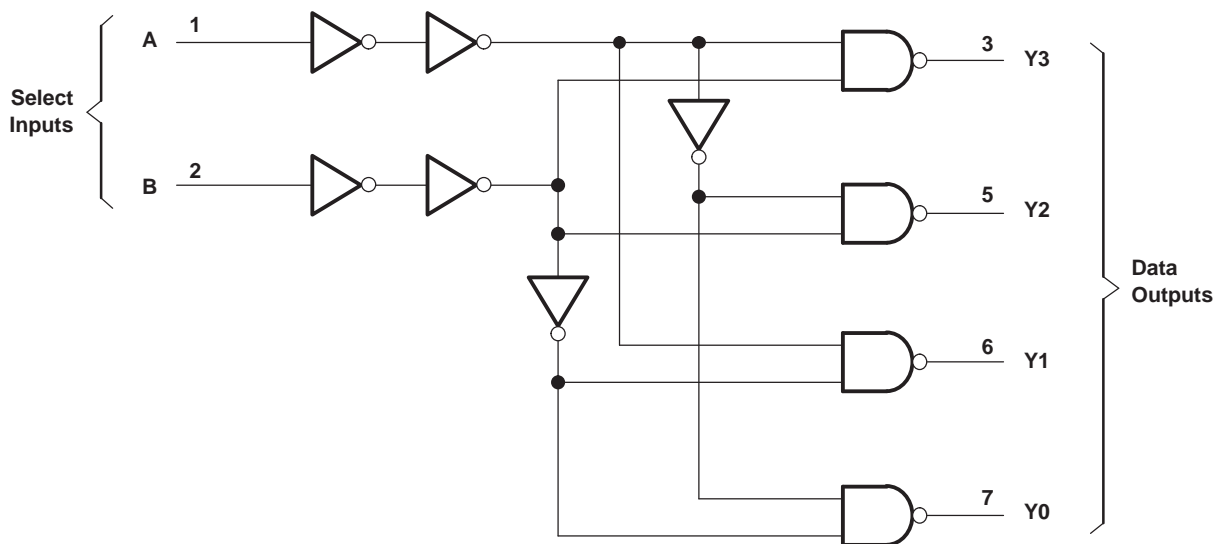

9.3 Feature Description

NanoStar and NanoFree package technology is a major breakthrough in device packaging concepts, using the die as the package.

This device is fully specified for partial-power-down applications using I_{off} . The I_{off} circuitry disables the outputs, preventing damaging current backflow through the device when it is powered down.

9.4 Device Functional Modes

[表 4](#) lists the functional modes of the SN74LVC1G139 device.

表 4. Function Table

INPUTS		OUTPUTS			
B	A	Y ₀	Y ₁	Y ₂	Y ₃
L	L	L	H	H	H
L	H	H	L	H	H
H	L	H	H	L	H
H	H	H	H	H	L

10 Application and Implementation

注

Information in the following applications sections is not part of the TI component specification, and TI does not warrant its accuracy or completeness. TI's customers are responsible for determining suitability of components for their purposes. Customers should validate and test their design implementation to confirm system functionality.

10.1 Application Information

The SN74LVC1G139 device is a 2-of-4 decoder and demultiplexer. This device decodes the 2-bit address on inputs A (bit 0) and B (bit 1) then provides a logic low on the matching address output. It can produce 24 mA of drive current at 3.3 V, making it ideal for driving multiple outputs.

10.2 Typical Application

This is an address line decoder using a 16-bit bus example; address bus lines 14 and 15 are decoded and drive four active low chip selects. Each output covers 16K address space mapped by the address bus lines 0 through 13.



图 7. Typical Application Diagram

10.2.1 Design Requirements

This device uses CMOS technology and has balanced output drive. Take care to avoid bus contention because it can drive currents that would exceed maximum limits. Outputs can be combined to produce higher drive but the high drive will also create faster edges into light loads so routing and load conditions should be considered to prevent ringing.

10.2.2 Detailed Design Procedure

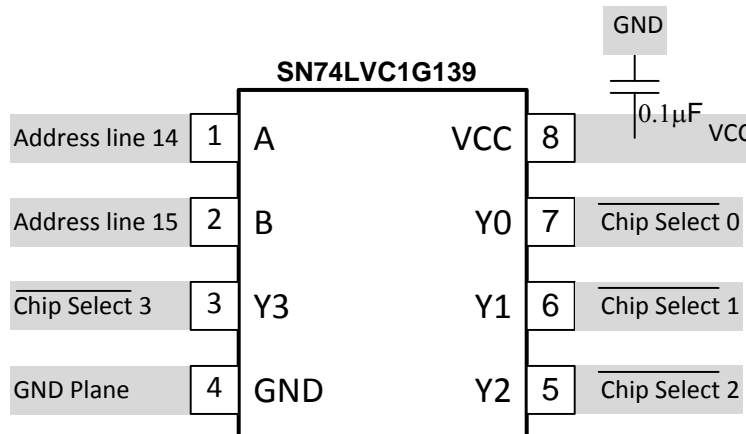
1. Recommended Input Conditions:

- Rise time and fall time specifications ($\Delta t/\Delta V$) are shown in the [Recommended Operating Conditions](#) table.
- Specified high (V_{IH}) and low voltage (V_{IL}) levels are shown in the [Recommended Operating Conditions](#) table.
- Inputs are overvoltage tolerant allowing them to go as high as 5.5 V at any valid V_{CC} .

2. Recommend Output Conditions:

- Load currents should not exceed 50 mA per output and 100 mA total for the part.
- Series resistors on the output may be used if the user desires to slow the output edge signal or limit the output current.

Typical Application (接下页)

10.2.3 Application Curve



图 8. I_{CC} vs Frequency
Load is 15 pF

11 Power Supply Recommendations

The power supply can be any voltage between the minimum and maximum supply voltage rating located in the *Recommended Operating Conditions* table.

Each V_{CC} terminal should have a good bypass capacitor to prevent power disturbance. For devices with a single supply, a 0.1-μF capacitor is recommended. If there are multiple V_{CC} terminals, then 0.01-μF or 0.022-μF capacitors are recommended for each power terminal. Parallel multiple bypass capacitors are allowed to reject different frequencies of noise. Multiple bypass capacitors may be paralleled to reject different frequencies of noise. The bypass capacitor must be installed as close to the power terminal as possible for the best results.

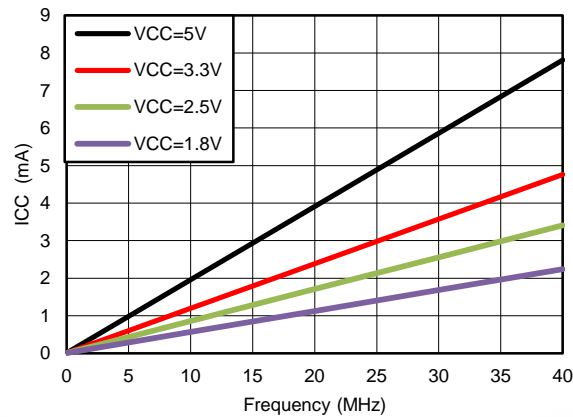
12 Layout

12.1 Layout Guidelines

When using multiple bit logic devices, inputs should not float. In many cases, functions or parts of functions of digital logic devices are unused. Some examples are when only two inputs of a triple-input AND gate are used, or when only 3 of the 4-buffer gates are used. Such input pins should not be left unconnected because the undefined voltages at the outside connections result in undefined operational states.

Specified in 图 9 are rules that must be observed under all circumstances. All unused inputs of digital logic devices must be connected to a high or low bias to prevent them from floating. The logic level that should be applied to any particular unused input depends on the function of the device. Generally they will be tied to GND or V_{CC}, whichever makes more sense or is more convenient.

12.2 Layout Example



图 9. Layout Diagram

13 器件和文档支持

13.1 文档支持

13.1.1 相关文档

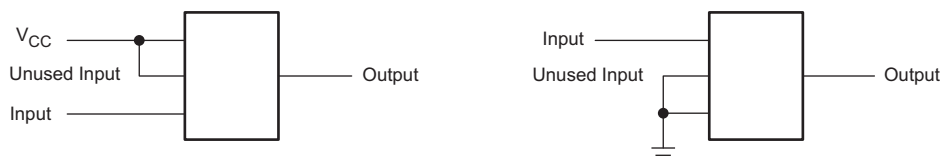
请参阅如下相关文档：

德州仪器 (TI)，《慢速或浮点 CMOS 输入的影响》应用报告

13.2 社区资源

下列链接提供到 TI 社区资源的连接。链接的内容由各个分销商“按照原样”提供。这些内容并不构成 TI 技术规范，并且不一定反映 TI 的观点；请参阅 TI 的《使用条款》。

TI E2E™ 在线社区 **TI 的工程师对工程师 (E2E) 社区**。此社区的创建目的在于促进工程师之间的协作。在 e2e.ti.com 中，您可以咨询问题、分享知识、拓展思路并与同行工程师一道帮助解决问题。

设计支持 **TI 参考设计支持** 可帮助您快速查找有帮助的 E2E 论坛、设计支持工具以及技术支持的联系信息。

13.3 商标

NanoStar, NanoFree, E2E are trademarks of Texas Instruments.
All other trademarks are the property of their respective owners.

13.4 静电放电警告



这些装置包含有限的内置 ESD 保护。存储或装卸时，应将导线一起截短或将装置放置于导电泡棉中，以防止 MOS 门极遭受静电损伤。

13.5 Glossary

SLYZ022 — *TI Glossary*.

This glossary lists and explains terms, acronyms, and definitions.

14 机械、封装和可订购信息

以下页面包含机械、封装和可订购信息。这些信息是指定器件的最新可用数据。数据如有变更，恕不另行通知和修订此文档。如欲获取此数据表的浏览器版本，请参阅左侧的导航。

PACKAGING INFORMATION

Orderable Device	Status (1)	Package Type	Package Drawing	Pins	Package Qty	Eco Plan (2)	Lead finish/ Ball material (6)	MSL Peak Temp (3)	Op Temp (°C)	Device Marking (4/5)	Samples
74LVC1G139DCTRE4	ACTIVE	SM8	DCT	8	3000	RoHS & Green	NIPDAU	Level-1-260C-UNLIM	-40 to 85	C39 (R, Z)	Samples
74LVC1G139DCUTG4	ACTIVE	VSSOP	DCU	8	250	RoHS & Green	NIPDAU	Level-1-260C-UNLIM	-40 to 85	C39R	Samples
SN74LVC1G139DCTR	ACTIVE	SM8	DCT	8	3000	RoHS & Green	NIPDAU	Level-1-260C-UNLIM	-40 to 85	C39 (R, Z)	Samples
SN74LVC1G139DCTT	ACTIVE	SM8	DCT	8	250	RoHS & Green	NIPDAU	Level-1-260C-UNLIM	-40 to 85	C39 (R, Z)	Samples
SN74LVC1G139DCUR	ACTIVE	VSSOP	DCU	8	3000	RoHS & Green	NIPDAU SN	Level-1-260C-UNLIM	-40 to 85	(C39J, C39Q, C39R)	Samples
SN74LVC1G139DCUT	ACTIVE	VSSOP	DCU	8	250	RoHS & Green	NIPDAU SN	Level-1-260C-UNLIM	-40 to 85	(C39J, C39Q, C39R)	Samples
SN74LVC1G139YZPR	ACTIVE	DSBGA	YZP	8	3000	RoHS & Green	SNAGCU	Level-1-260C-UNLIM	-40 to 85	DFN	Samples

(1) The marketing status values are defined as follows:

ACTIVE: Product device recommended for new designs.

LIFEBUY: TI has announced that the device will be discontinued, and a lifetime-buy period is in effect.

NRND: Not recommended for new designs. Device is in production to support existing customers, but TI does not recommend using this part in a new design.

PREVIEW: Device has been announced but is not in production. Samples may or may not be available.

OBSOLETE: TI has discontinued the production of the device.

(2) **RoHS:** TI defines "RoHS" to mean semiconductor products that are compliant with the current EU RoHS requirements for all 10 RoHS substances, including the requirement that RoHS substance do not exceed 0.1% by weight in homogeneous materials. Where designed to be soldered at high temperatures, "RoHS" products are suitable for use in specified lead-free processes. TI may reference these types of products as "Pb-Free".

RoHS Exempt: TI defines "RoHS Exempt" to mean products that contain lead but are compliant with EU RoHS pursuant to a specific EU RoHS exemption.

Green: TI defines "Green" to mean the content of Chlorine (Cl) and Bromine (Br) based flame retardants meet JS709B low halogen requirements of <=1000ppm threshold. Antimony trioxide based flame retardants must also meet the <=1000ppm threshold requirement.

(3) MSL, Peak Temp. - The Moisture Sensitivity Level rating according to the JEDEC industry standard classifications, and peak solder temperature.

(4) There may be additional marking, which relates to the logo, the lot trace code information, or the environmental category on the device.

(5) Multiple Device Markings will be inside parentheses. Only one Device Marking contained in parentheses and separated by a "~" will appear on a device. If a line is indented then it is a continuation of the previous line and the two combined represent the entire Device Marking for that device.

⁽⁶⁾ Lead finish/Ball material - Orderable Devices may have multiple material finish options. Finish options are separated by a vertical ruled line. Lead finish/Ball material values may wrap to two lines if the finish value exceeds the maximum column width.

Important Information and Disclaimer: The information provided on this page represents TI's knowledge and belief as of the date that it is provided. TI bases its knowledge and belief on information provided by third parties, and makes no representation or warranty as to the accuracy of such information. Efforts are underway to better integrate information from third parties. TI has taken and continues to take reasonable steps to provide representative and accurate information but may not have conducted destructive testing or chemical analysis on incoming materials and chemicals. TI and TI suppliers consider certain information to be proprietary, and thus CAS numbers and other limited information may not be available for release.

In no event shall TI's liability arising out of such information exceed the total purchase price of the TI part(s) at issue in this document sold by TI to Customer on an annual basis.

TAPE AND REEL INFORMATION



QUADRANT ASSIGNMENTS FOR PIN 1 ORIENTATION IN TAPE



*All dimensions are nominal

Device	Package Type	Package Drawing	Pins	SPQ	Reel Diameter (mm)	Reel Width W1 (mm)	A0 (mm)	B0 (mm)	K0 (mm)	P1 (mm)	W (mm)	Pin1 Quadrant
74LVC1G139DCUTG4	VSSOP	DCU	8	250	180.0	8.4	2.25	3.35	1.05	4.0	8.0	Q3
SN74LVC1G139DCTR	SM8	DCT	8	3000	180.0	13.0	3.35	4.5	1.55	4.0	12.0	Q3
SN74LVC1G139DCTT	SM8	DCT	8	250	180.0	13.0	3.35	4.5	1.55	4.0	12.0	Q3
SN74LVC1G139DCUR	VSSOP	DCU	8	3000	180.0	8.4	2.25	3.35	1.05	4.0	8.0	Q3
SN74LVC1G139DCUR	VSSOP	DCU	8	3000	178.0	9.5	2.25	3.35	1.05	4.0	8.0	Q3
SN74LVC1G139DCUR	VSSOP	DCU	8	3000	178.0	9.0	2.25	3.35	1.05	4.0	8.0	Q3
SN74LVC1G139DCUT	VSSOP	DCU	8	250	178.0	9.0	2.25	3.35	1.05	4.0	8.0	Q3
SN74LVC1G139DCUT	VSSOP	DCU	8	250	178.0	9.5	2.25	3.35	1.05	4.0	8.0	Q3
SN74LVC1G139YZPR	DSBGA	YZP	8	3000	178.0	9.2	1.02	2.02	0.63	4.0	8.0	Q1

TAPE AND REEL BOX DIMENSIONS

*All dimensions are nominal

Device	Package Type	Package Drawing	Pins	SPQ	Length (mm)	Width (mm)	Height (mm)
74LVC1G139DCUTG4	VSSOP	DCU	8	250	202.0	201.0	28.0
SN74LVC1G139DCTR	SM8	DCT	8	3000	182.0	182.0	20.0
SN74LVC1G139DCTT	SM8	DCT	8	250	182.0	182.0	20.0
SN74LVC1G139DCUR	VSSOP	DCU	8	3000	202.0	201.0	28.0
SN74LVC1G139DCUR	VSSOP	DCU	8	3000	202.0	201.0	28.0
SN74LVC1G139DCUR	VSSOP	DCU	8	3000	180.0	180.0	18.0
SN74LVC1G139DCUT	VSSOP	DCU	8	250	180.0	180.0	18.0
SN74LVC1G139DCUT	VSSOP	DCU	8	250	202.0	201.0	28.0
SN74LVC1G139YZPR	DSBGA	YZP	8	3000	220.0	220.0	35.0

DCU (S-PDSO-G8)

PLASTIC SMALL OUTLINE PACKAGE (DIE DOWN)

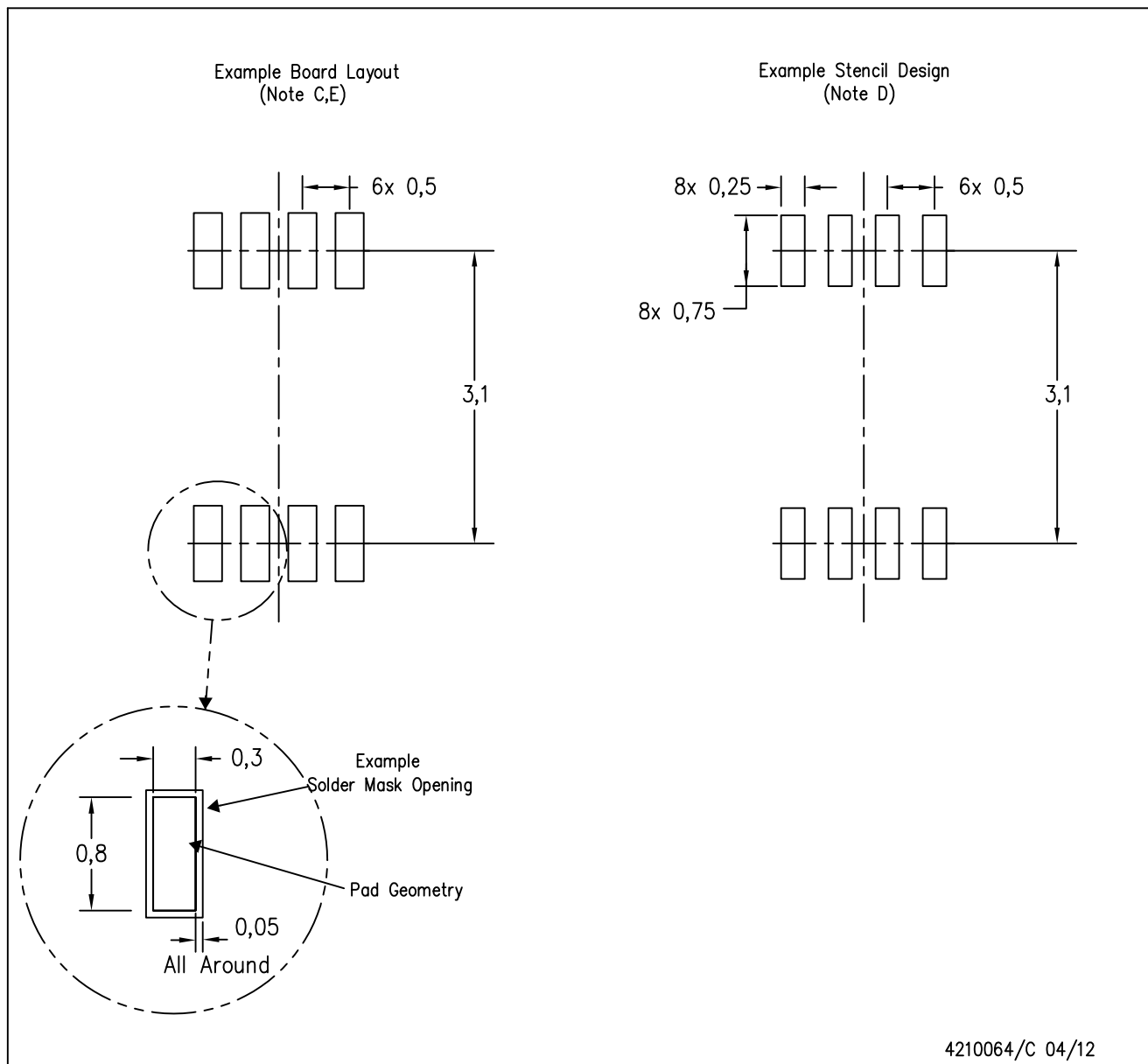

4210064/C 04/12

- NOTES:
- A. All linear dimensions are in millimeters.
 - B. This drawing is subject to change without notice.
 - C. Publication IPC-7351 is recommended for alternate designs.
 - D. Laser cutting apertures with trapezoidal walls and also rounding corners will offer better paste release. Customers should contact their board assembly site for stencil design recommendations. Refer to IPC-7525 for other stencil recommendations.
 - E. Customers should contact their board fabrication site for solder mask tolerances between and around signal pads.

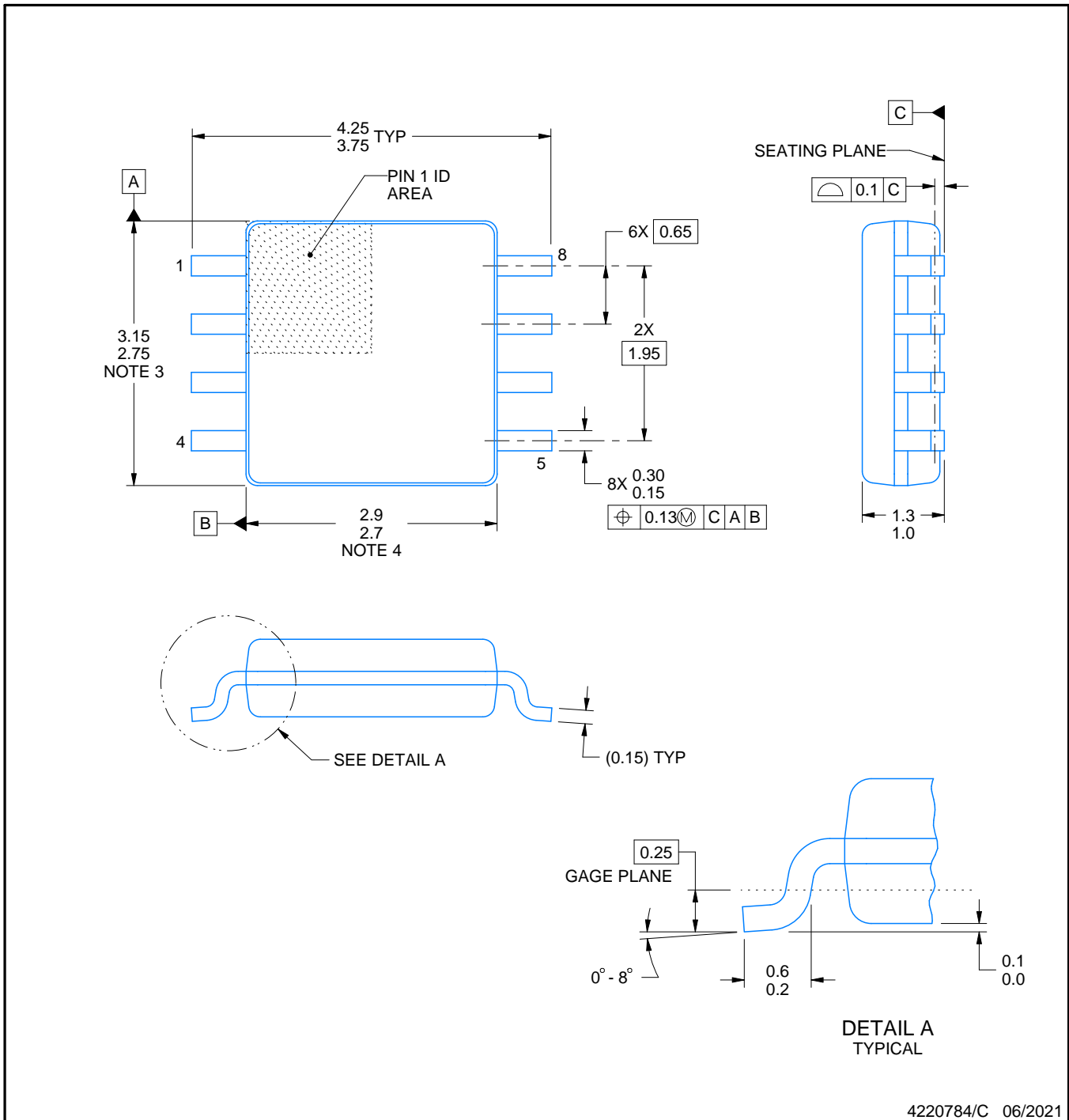
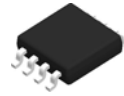

4220784/C 06/2021

NOTES:

1. All linear dimensions are in millimeters. Dimensions in parenthesis are for reference only. Dimensioning and tolerancing per ASME Y14.5M.
2. This drawing is subject to change without notice.
3. This dimension does not include mold flash, protrusions, or gate burrs. Mold flash, protrusions, or gate burrs shall not exceed 0.15 mm per side.
4. This dimension does not include interlead flash. Interlead flash shall not exceed 0.25 mm per side.

EXAMPLE BOARD LAYOUT

DCT0008A

SSOP - 1.3 mm max height

SMALL OUTLINE PACKAGE

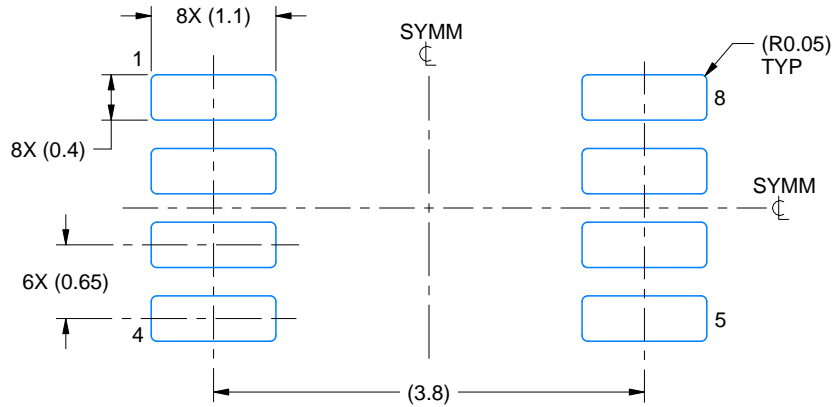

LAND PATTERN EXAMPLE
EXPOSED METAL SHOWN
SCALE:15X

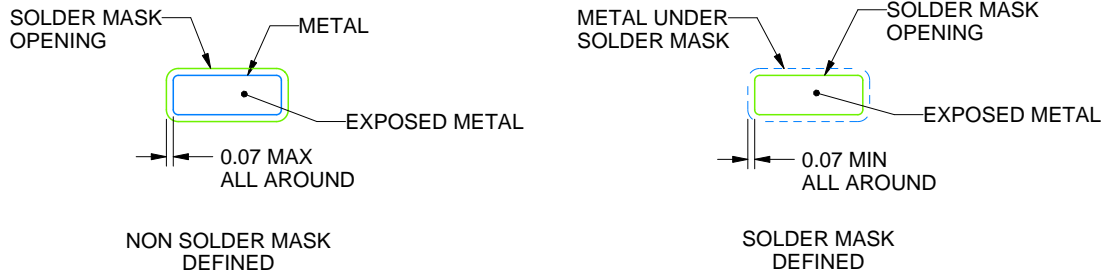

SOLDER MASK DETAILS

4220784/C 06/2021

NOTES: (continued)

- 5. Publication IPC-7351 may have alternate designs.
- 6. Solder mask tolerances between and around signal pads can vary based on board fabrication site.

EXAMPLE STENCIL DESIGN

DCT0008A

SSOP - 1.3 mm max height

SMALL OUTLINE PACKAGE

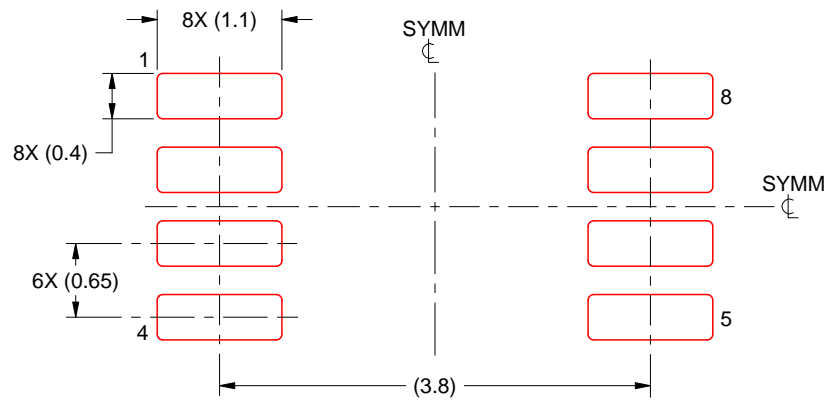

SOLDER PASTE EXAMPLE
BASED ON 0.125 mm THICK STENCIL
SCALE:15X

4220784/C 06/2021

NOTES: (continued)

7. Laser cutting apertures with trapezoidal walls and rounded corners may offer better paste release. IPC-7525 may have alternate design recommendations.
8. Board assembly site may have different recommendations for stencil design.

YZP0008

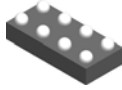

PACKAGE OUTLINE

DSBGA - 0.5 mm max height

DIE SIZE BALL GRID ARRAY

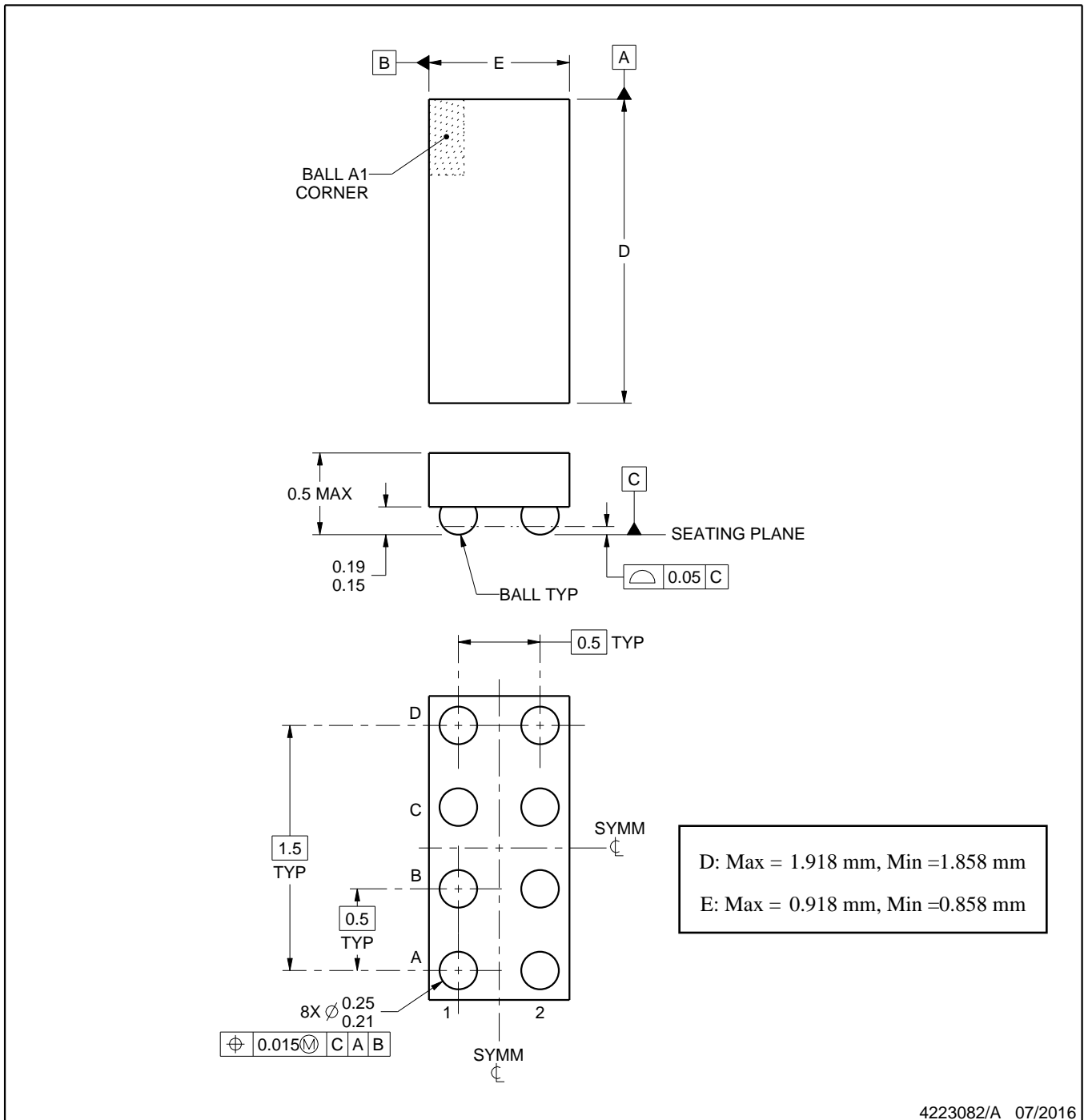

4223082/A 07/2016

NOTES:

1. All linear dimensions are in millimeters. Any dimensions in parenthesis are for reference only. Dimensioning and tolerancing per ASME Y14.5M.
2. This drawing is subject to change without notice.

EXAMPLE BOARD LAYOUT

YZP0008

DSBGA - 0.5 mm max height

DIE SIZE BALL GRID ARRAY

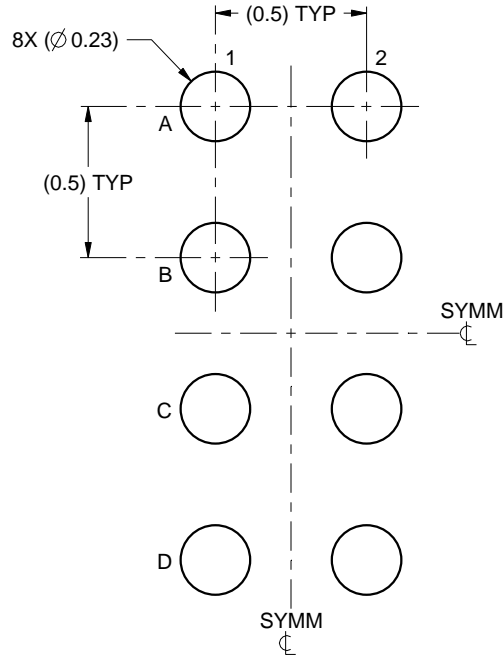

LAND PATTERN EXAMPLE
SCALE:40X

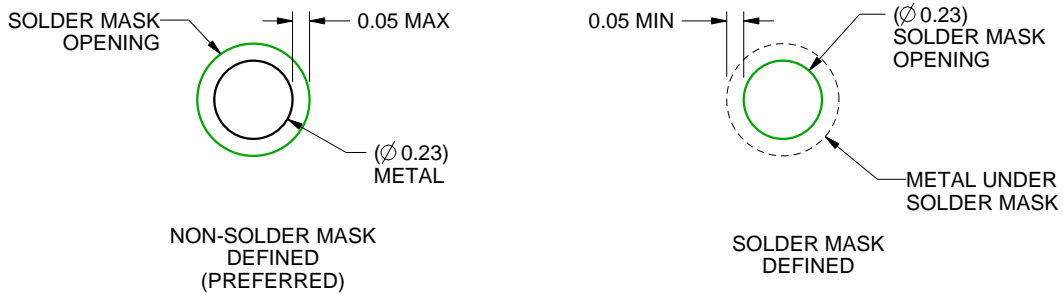

SOLDER MASK DETAILS
NOT TO SCALE

4223082/A 07/2016

NOTES: (continued)

3. Final dimensions may vary due to manufacturing tolerance considerations and also routing constraints. For more information, see Texas Instruments literature number SNVA009 (www.ti.com/lit/snva009).

EXAMPLE STENCIL DESIGN

YZP0008

DSBGA - 0.5 mm max height

DIE SIZE BALL GRID ARRAY

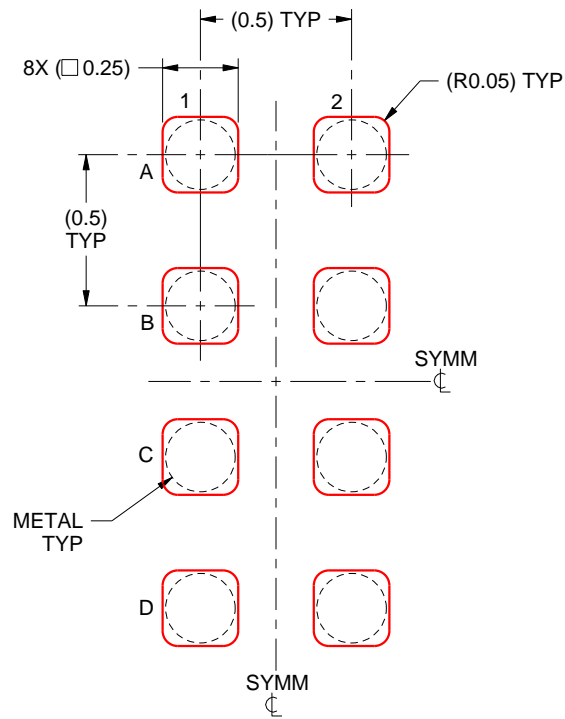

SOLDER PASTE EXAMPLE
BASED ON 0.1 mm THICK STENCIL
SCALE:40X

4223082/A 07/2016

NOTES: (continued)

4. Laser cutting apertures with trapezoidal walls and rounded corners may offer better paste release.

重要声明和免责声明

TI“按原样”提供技术和可靠性数据（包括数据表）、设计资源（包括参考设计）、应用或其他设计建议、网络工具、安全信息和其他资源，不保证没有瑕疵且不做任何明示或暗示的担保，包括但不限于对适销性、某特定用途方面的适用性或不侵犯任何第三方知识产权的暗示担保。

这些资源可供使用 TI 产品进行设计的熟练开发人员使用。您将自行承担以下全部责任：(1) 针对您的应用选择合适的 TI 产品，(2) 设计、验证并测试您的应用，(3) 确保您的应用满足相应标准以及任何其他功能安全、信息安全、监管或其他要求。

这些资源如有变更，恕不另行通知。TI 授权您仅可将这些资源用于研发本资源所述的 TI 产品的应用。严禁对这些资源进行其他复制或展示。您无权使用任何其他 TI 知识产权或任何第三方知识产权。您应全额赔偿因在这些资源的使用中对 TI 及其代表造成的任何索赔、损害、成本、损失和债务，TI 对此概不负责。

TI 提供的产品受 [TI 的销售条款](#) 或 [ti.com](#) 上其他适用条款/TI 产品随附的其他适用条款的约束。TI 提供这些资源并不会扩展或以其他方式更改 TI 针对 TI 产品发布的适用的担保或担保免责声明。

TI 反对并拒绝您可能提出的任何其他或不同的条款。

邮寄地址：Texas Instruments, Post Office Box 655303, Dallas, Texas 75265

Copyright © 2022，德州仪器 (TI) 公司