

## 3.3 V Dual LVTTTL to Differential LVPECL Translator

### FEATURES

- 450 ps (typ) Propagation Delay
- Operating Range:  $V_{CC}$  3.0 V to 3.8 with  $GND = 0$  V
- <50 ps (max) Output to Output Skew
- Built-in Temperature Compensation
- Drop in Compatible to MC100LVELT22

### APPLICATIONS

- Data and Clock Transmission Over Backplane
- Signaling Level Conversion for Clock or Data

### DESCRIPTION

The SN65ELT22 is a dual LVTTTL to differential LVPECL translator buffer. It operates on +3V supply and ground only. The output is driven default high when the inputs are left floating or unused. The low output skew makes the device the ideal solution for clock or data signal translation.

The SN65LVELT22 is housed in an industry standard SOIC-8 package and is also available in TSSOP-8 package option.

### PINOUT ASSIGNMENT

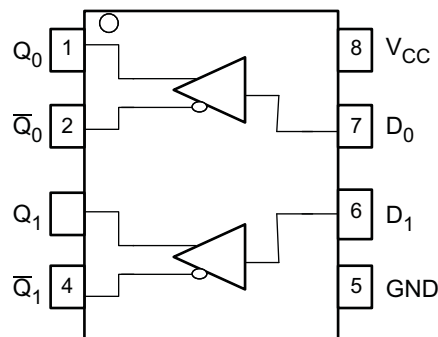

**Table 1. Pin Description**

PIN	FUNCTION
$D_0, D_1$	TTL inputs
$Q_0, \bar{Q}_0, Q_1, \bar{Q}_1$	PECL/ECL outputs
$V_{CC}$	Positive supply
GND	Ground

### ORDERING INFORMATION<sup>(1)</sup>

PART NUMBER	PART MARKING	PACKAGE	LEAD FINISH
SN65LVELT22D	SN65LVELT22	SOIC	NiPdAu
SN65LVELT22DGK	SN65LVELT22	SOIC-TSSOP	NiPdAu

(1) Leaded device options not initially available. Contact TI sales representative for further details.



Please be aware that an important notice concerning availability, standard warranty, and use in critical applications of Texas Instruments semiconductor products and disclaimers thereto appears at the end of this data sheet.



These devices have limited built-in ESD protection. The leads should be shorted together or the device placed in conductive foam during storage or handling to prevent electrostatic damage to the MOS gates.

## ABSOLUTE MAXIMUM RATINGS<sup>(1)</sup>

		VALUE	UNIT
Absolute PECL mode supply voltage, $V_{CC}$	$GND = 0\text{ V}$	6	V
$V_{IN}$ input voltage	$V_I \leq V_{CC}$	6	V
Output current	Continuous	50	mA
	Surge	100	
Operating temperature range		–40 to 85	°C
Storage temperature range		–65 to 150	°C

(1) Stresses beyond those listed under *absolute maximum ratings* may cause permanent damage to the device. These are stress ratings only, and functional operation of the device at these or any other conditions beyond those indicated under *recommended operating conditions* is not implied. Exposure to absolute-maximum-rated conditions for extended periods may affect device reliability.

## POWER DISSIPATION RATINGS

PACKAGE	CIRCUIT BOARD MODEL	POWER RATING $T_A < 25^\circ\text{C}$ (mW)	THERMAL RESISTANCE, JUNCTION TO AMBIENT NO AIRFLOW	DERATING FACTOR $T_A > 25^\circ\text{C}$ (mW/°C)	POWER RATING $T_A = 85^\circ\text{C}$ (mW)
SOIC	Low-K	719	139	7	288
	High-K	840	119	8	336
SOIC-TSSOP	Low-K	469	213	5	188
	High-K	527	189	5	211

## THERMAL CHARACTERISTICS

PARAMETER		PACKAGE	VALUE	UNIT
$\theta_{JB}$	Junction-to Board Thermal Resistance	SOIC	79	°C/W
		SOIC-TSSOP	120	
$\theta_{JC}$	Junction-to Case Thermal Resistance	SOIC	98	°C/W
		SOIC-TSSOP	74	

## KEY ATTRIBUTES

CHARACTERISTICS	VALUE
Moisture sensitivity level	Level 1
Flammability rating (Oxygen Index: 28 to 34)	UL 94 V-0 at 0.125 in
ESD-HBM	4 kV
ESD-machine model	200 V
ESD-charge device model	2 kV
Meets or exceeds JEDEC Spec EIA/JESD78 latchup test	

**PECL DC CHARACTERISTICS<sup>(1)</sup> ( $V_{CC} = 3.3\text{ V}$ ,  $GND = 0.0\text{ V}$ <sup>(2)</sup>)**

CHARACTERISTICS		-40°C			25°C			85°C			UNIT
		MIN	TYP	MAX	MIN	TYP	MAX	MIN	TYP	MAX	
$I_{CC}$	Power Supply Current		23	33		25	33		26	33	mA
$V_{OH}$	Output HIGH Voltage <sup>(3)</sup>	2275	2317	2420	2275	2331	2420	2275	2343	2420	mV
$V_{OL}$	Output LOW Voltage <sup>(3)</sup>	1490	1558	1680	1490	1556	1680	1490	1555	1680	mV

- (1) Device will meet the specifications after thermal balance has been established when mounted in a socket or printed circuit board with maintained transverse airflow greater than 500 lfm. Electrical parameters are assured only over the declared operating temperature range. Functional operation of the device exceeding these conditions is not implied. Device specification limit values are applied individually under normal operating conditions and not valid simultaneously.
- (2) Input parameters vary 1:1 with  $V_{CC}$ .  $V_{CC}$  can vary  $\pm 0.15\text{ V}$
- (3) Outputs are terminated through a 50- $\Omega$  resistor to  $V_{CC} - 2.0\text{ V}$ .

**TTL DC CHARACTERISTICS<sup>(1)</sup> ( $V_{CC} = 3.3\text{ V}$ ;  $T_A = -40^\circ\text{C}$  to  $85^\circ\text{C}$ )**

CHARACTERISTIC		CONDITION			MIN	TYP	MAX	UNIT
$I_{IH}$	Input HIGH current	$V_{IN} = 2.7\text{ V}$					20	$\mu\text{A}$
$I_{IHH}$	Input HIGH current max	$V_{IN} = V_{CC}$					100	$\mu\text{A}$
$I_{IL}$	Input LOW current	$V_{IN} = 0.5\text{ V}$					-0.2	mA
$V_{IK}$	Input clamp diode voltage	$I_{IN} = -18\text{ mA}$					-1.2	V
$V_{IH}$	Input HIGH voltage				2.0			V
$V_{IL}$	Input LOW voltage						0.8	V

- (1) Device will meet the specifications after thermal balance has been established when mounted in a socket or printed circuit board with maintained transverse airflow greater than 500 lfm. Electrical parameters are assured only over the declared operating temperature range. Functional operation of the device exceeding these conditions is not implied. Device specification limit values are applied individually under normal operating conditions and not valid simultaneously.

**AC CHARACTERISTICS<sup>(1)</sup> ( $V_{CC} = 3.3\text{ V}$ ;  $GND = 0.0\text{ V}$ )**

CHARACTERISTIC		-40°C			25°C			85°C			UNIT
		MIN	TYP	MAX	MIN	TYP	MAX	MIN	TYP	MAX	
$f_{MAX}$	Max switching frequency <sup>(2)</sup> , see <a href="#">Figure 5</a>		1750			1750			1700		MHz
$t_{PLH}/t_{PHL}$	Propagation delay to output at 1.5V, see <a href="#">Figure 4</a>	200	425	550	200	445	550	200	460	550	ps
$t_{SKEW}$	Within – device skew <sup>(3)</sup>		20	50		20	50		20	50	ps
	Device-to-device skew <sup>(4)</sup>		30	100		30	100		30	100	
$t_{JITTER}$	Random clock jitter (RMS)		0.5	1.0		0.5	1.0		0.5	1.0	ps
$t_r/t_f$	Output rise/fall times Q (20%–80%)		300	500		300	500		300	500	ps

- (1) Device will meet the specifications after thermal balance has been established when mounted in a socket or printed circuit board with maintained transverse airflow greater than 500 lfm. Electrical parameters are assured only over the declared operating temperature range. Functional operation of the device exceeding these conditions is not implied. Device specification limit values are applied individually under normal operating conditions and not valid simultaneously.
- (2) Maximum switching frequency measured at output amplitude of 300 mV<sub>pp</sub>.
- (3) This is measured between outputs under the identical transitions and conditions on any one device.
- (4) Device-Device Skew is defined as identical transitions at identical  $V_{CC}$  levels.

Typical Termination for Output Driver

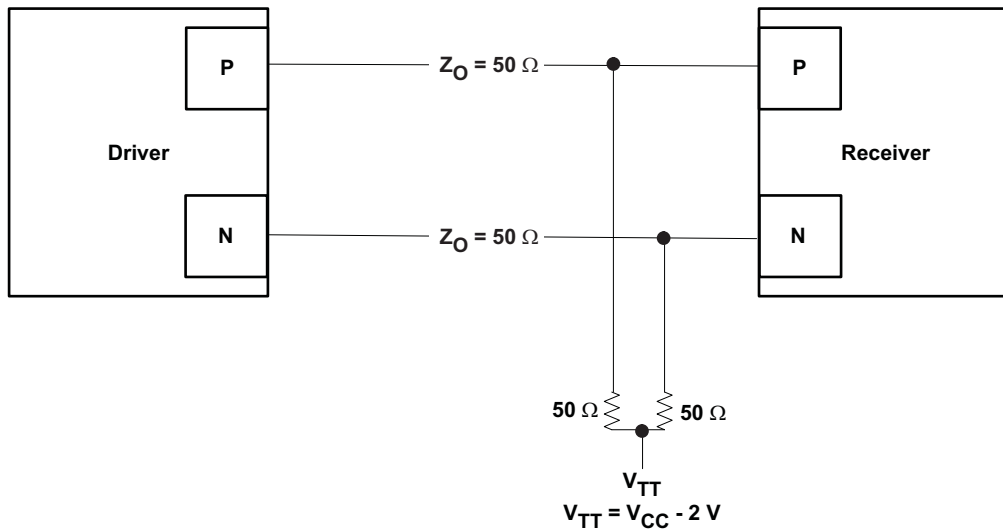

Figure 1. Termination for Output Driver

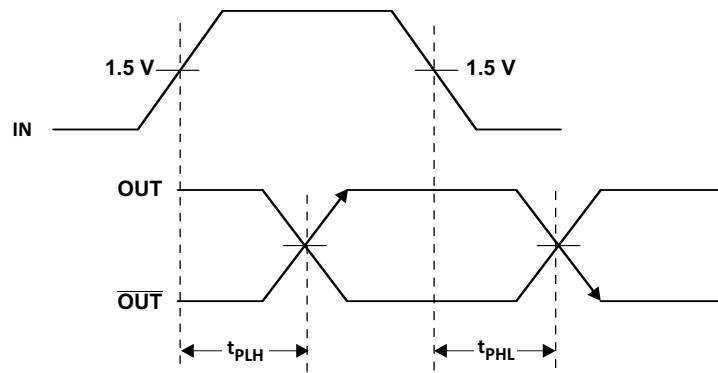

Figure 2. Output Propagation Delay



Figure 3. Output Rise and Fall Times

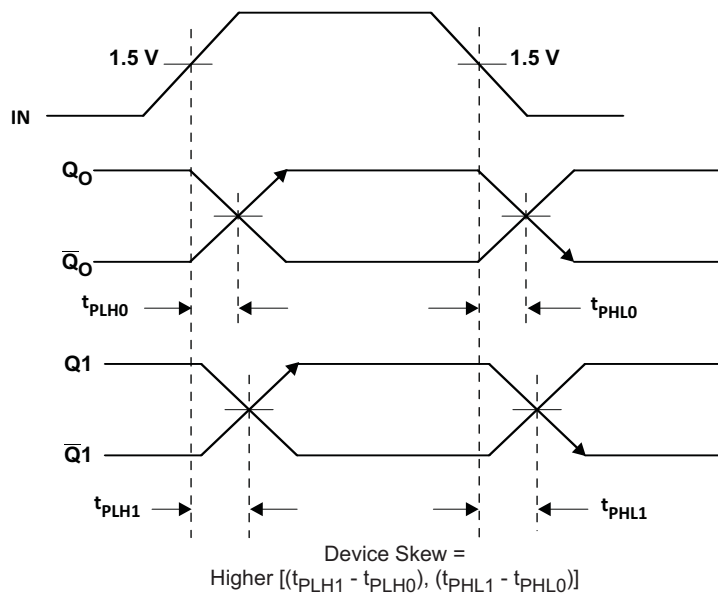

Figure 4. Device Skew

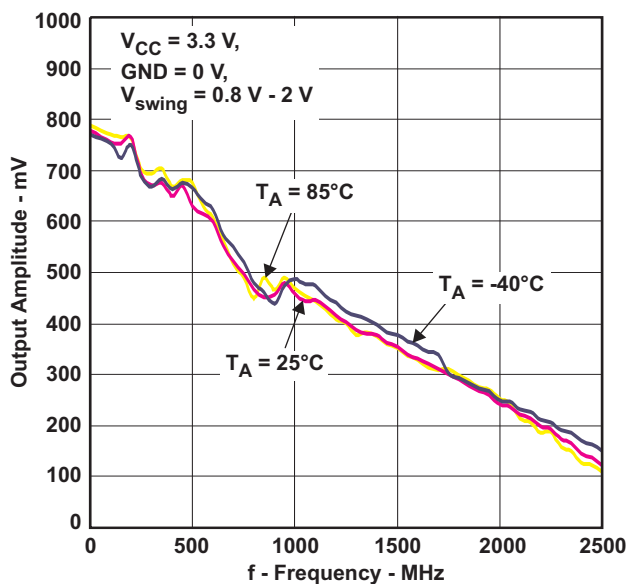

Figure 5. Output Amplitude vs. Frequency

**TAPE AND REEL INFORMATION**

**QUADRANT ASSIGNMENTS FOR PIN 1 ORIENTATION IN TAPE**

\*All dimensions are nominal

Device	Package Type	Package Drawing	Pins	SPQ	Reel Diameter (mm)	Reel Width W1 (mm)	A0 (mm)	B0 (mm)	K0 (mm)	P1 (mm)	W (mm)	Pin1 Quadrant
SN65LVELT22DGKR	VSSOP	DGK	8	2500	330.0	12.4	5.3	3.4	1.4	8.0	12.0	Q1
SN65LVELT22DR	SOIC	D	8	2500	330.0	12.4	6.4	5.2	2.1	8.0	12.0	Q1

**TAPE AND REEL BOX DIMENSIONS**



\*All dimensions are nominal

Device	Package Type	Package Drawing	Pins	SPQ	Length (mm)	Width (mm)	Height (mm)
SN65LVELT22DGKR	VSSOP	DGK	8	2500	853.0	449.0	35.0
SN65LVELT22DR	SOIC	D	8	2500	853.0	449.0	35.0

**TUBE**

\*All dimensions are nominal

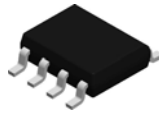
Device	Package Name	Package Type	Pins	SPQ	L (mm)	W (mm)	T (μm)	B (mm)
SN65LVELT22D	D	SOIC	8	75	506.6	8	3940	4.32
SN65LVELT22DGK	DGK	VSSOP	8	80	330.2	6.6	3005	1.88



D0008A

# PACKAGE OUTLINE

SOIC - 1.75 mm max height

SMALL OUTLINE INTEGRATED CIRCUIT

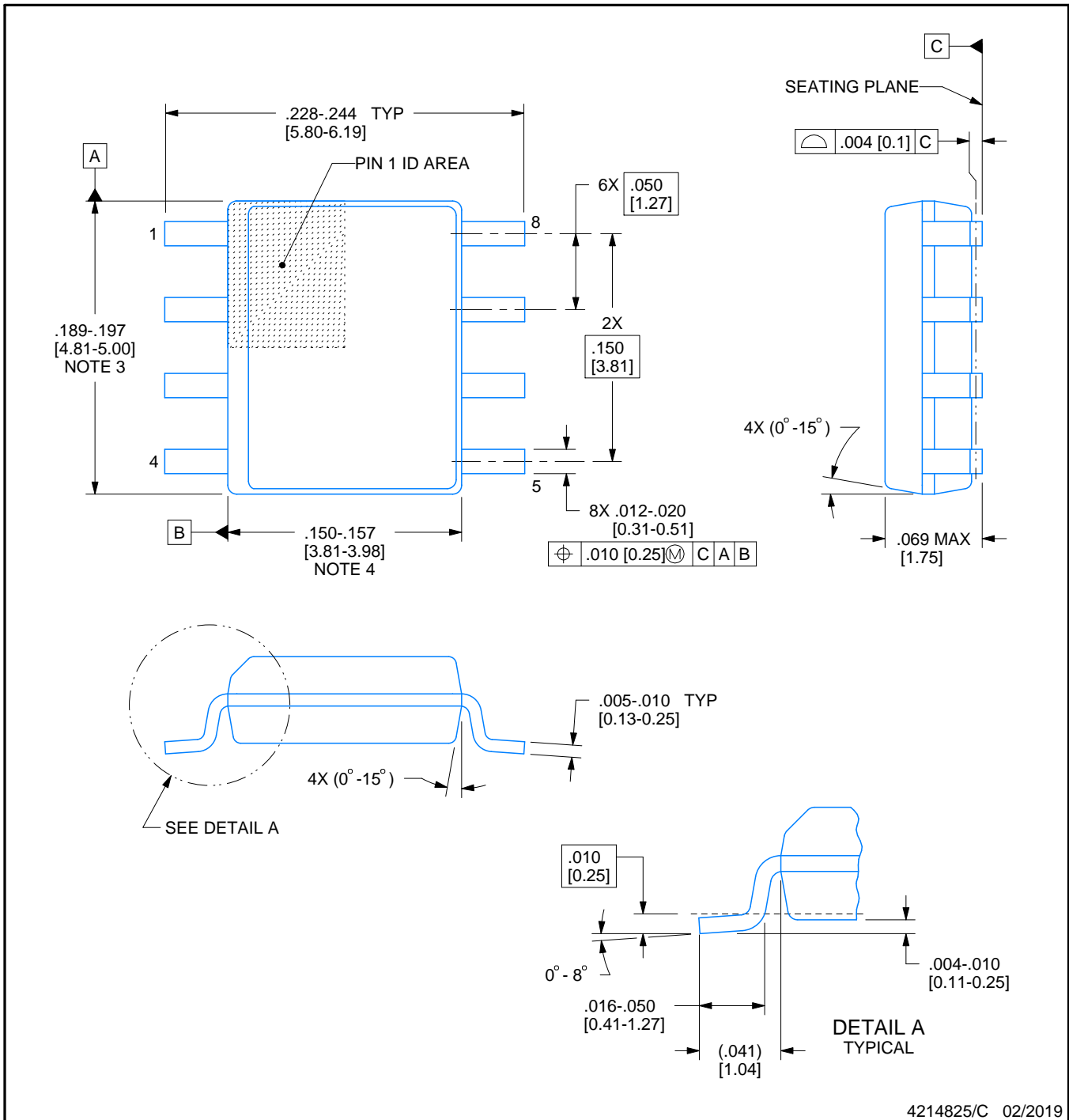

4214825/C 02/2019

NOTES:

- Linear dimensions are in inches [millimeters]. Dimensions in parenthesis are for reference only. Controlling dimensions are in inches. Dimensioning and tolerancing per ASME Y14.5M.
- This drawing is subject to change without notice.
- This dimension does not include mold flash, protrusions, or gate burrs. Mold flash, protrusions, or gate burrs shall not exceed .006 [0.15] per side.
- This dimension does not include interlead flash.
- Reference JEDEC registration MS-012, variation AA.

# EXAMPLE BOARD LAYOUT

D0008A

SOIC - 1.75 mm max height

SMALL OUTLINE INTEGRATED CIRCUIT

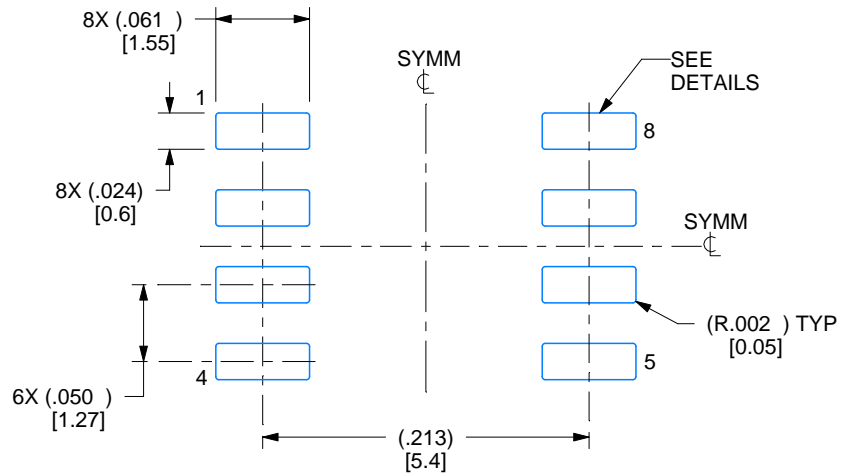

LAND PATTERN EXAMPLE  
 EXPOSED METAL SHOWN  
 SCALE:8X

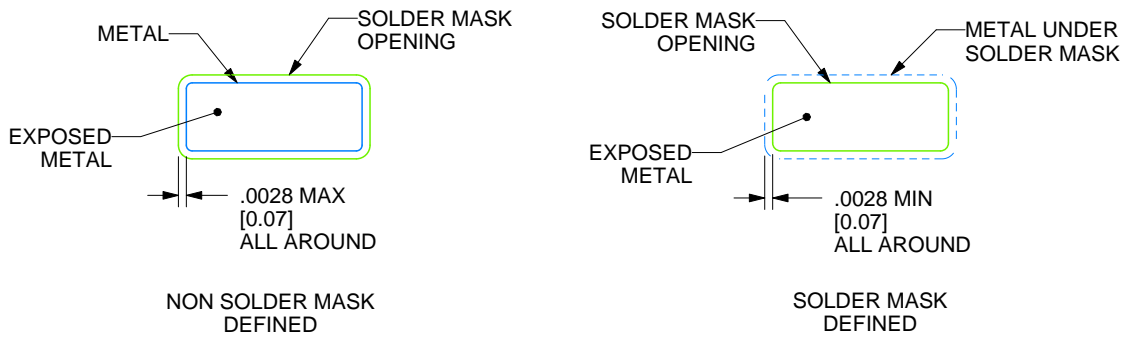

SOLDER MASK DETAILS

4214825/C 02/2019

NOTES: (continued)

- 6. Publication IPC-7351 may have alternate designs.
- 7. Solder mask tolerances between and around signal pads can vary based on board fabrication site.

# EXAMPLE STENCIL DESIGN

D0008A

SOIC - 1.75 mm max height

SMALL OUTLINE INTEGRATED CIRCUIT

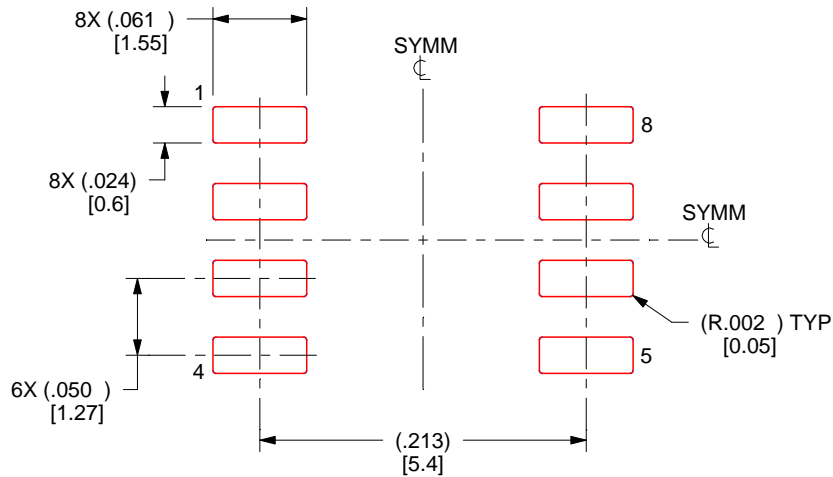

SOLDER PASTE EXAMPLE  
BASED ON .005 INCH [0.125 MM] THICK STENCIL  
SCALE:8X

4214825/C 02/2019

NOTES: (continued)

8. Laser cutting apertures with trapezoidal walls and rounded corners may offer better paste release. IPC-7525 may have alternate design recommendations.
9. Board assembly site may have different recommendations for stencil design.

DGK (S-PDSO-G8)

PLASTIC SMALL-OUTLINE PACKAGE

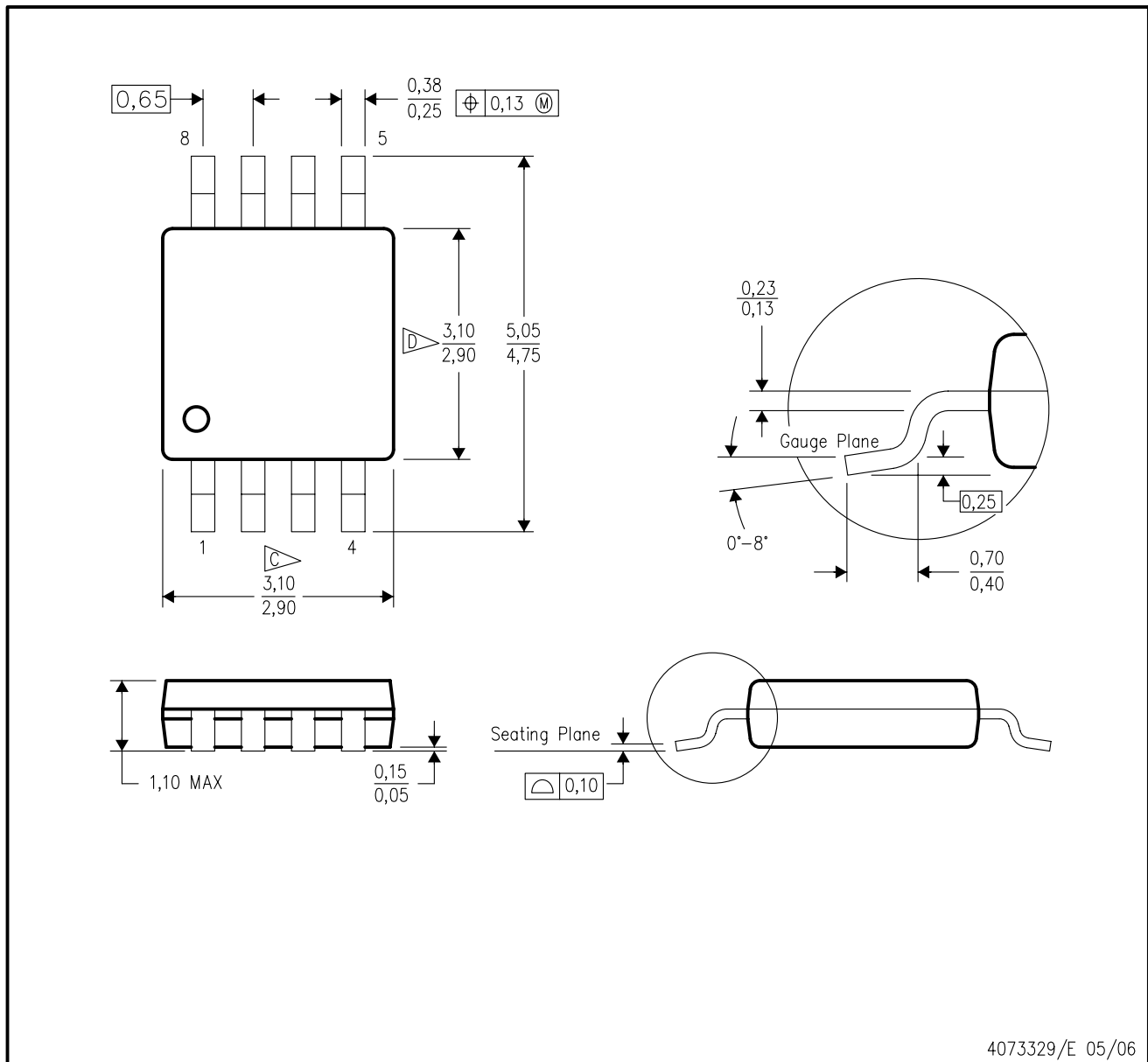

- NOTES:
- A. All linear dimensions are in millimeters.
  - B. This drawing is subject to change without notice.
  - C. Body length does not include mold flash, protrusions, or gate burrs. Mold flash, protrusions, or gate burrs shall not exceed 0.15 per end.
  - D. Body width does not include interlead flash. Interlead flash shall not exceed 0.50 per side.
  - E. Falls within JEDEC MO-187 variation AA, except interlead flash.

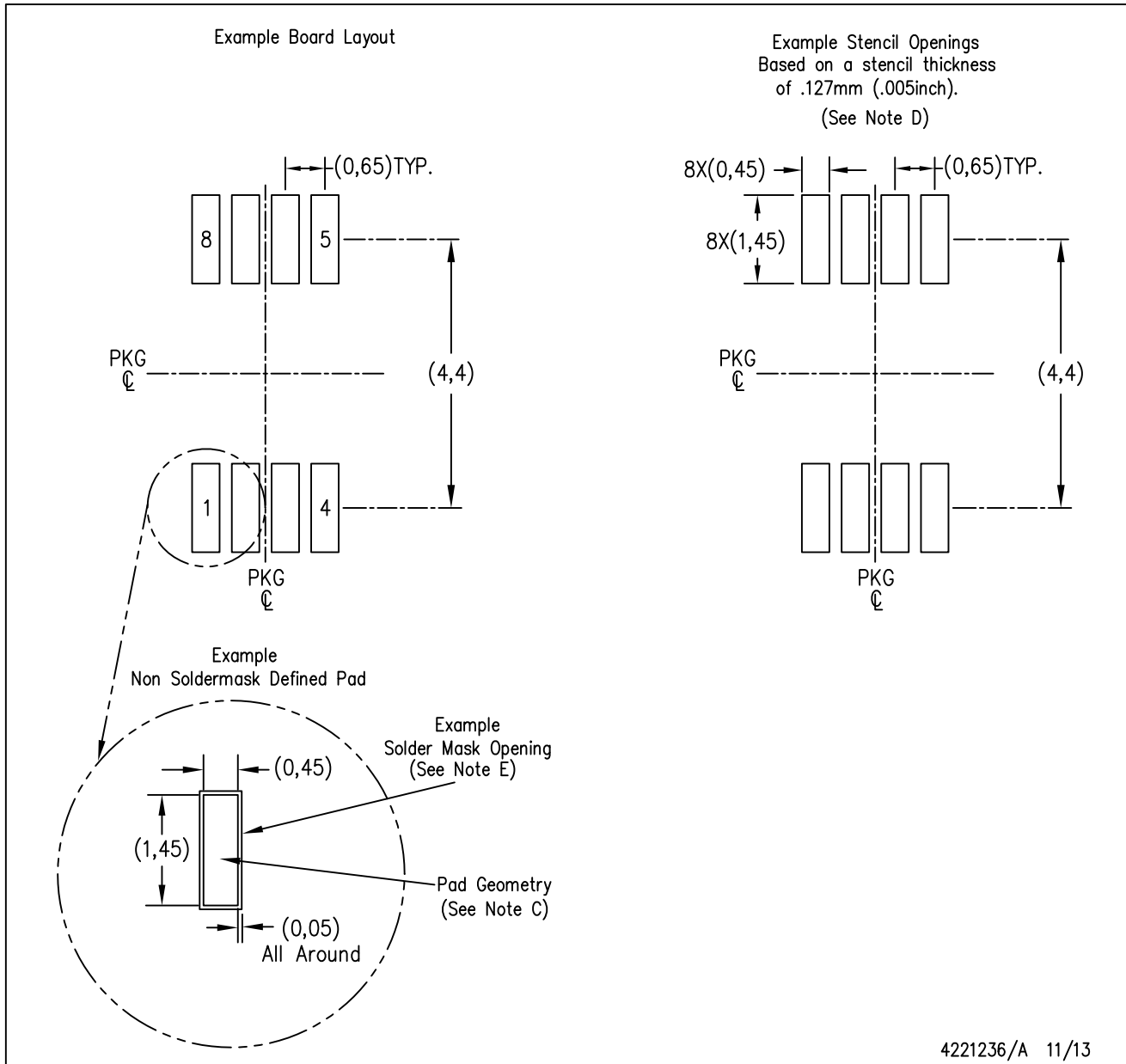

- NOTES:
- A. All linear dimensions are in millimeters.
  - B. This drawing is subject to change without notice.
  - C. Publication IPC-7351 is recommended for alternate designs.
  - D. Laser cutting apertures with trapezoidal walls and also rounding corners will offer better paste release. Customers should contact their board assembly site for stencil design recommendations. Refer to IPC-7525 for other stencil recommendations.
  - E. Customers should contact their board fabrication site for solder mask tolerances between and around signal pads.

## IMPORTANT NOTICE AND DISCLAIMER

TI PROVIDES TECHNICAL AND RELIABILITY DATA (INCLUDING DATA SHEETS), DESIGN RESOURCES (INCLUDING REFERENCE DESIGNS), APPLICATION OR OTHER DESIGN ADVICE, WEB TOOLS, SAFETY INFORMATION, AND OTHER RESOURCES "AS IS" AND WITH ALL FAULTS, AND DISCLAIMS ALL WARRANTIES, EXPRESS AND IMPLIED, INCLUDING WITHOUT LIMITATION ANY IMPLIED WARRANTIES OF MERCHANTABILITY, FITNESS FOR A PARTICULAR PURPOSE OR NON-INFRINGEMENT OF THIRD PARTY INTELLECTUAL PROPERTY RIGHTS.

These resources are intended for skilled developers designing with TI products. You are solely responsible for (1) selecting the appropriate TI products for your application, (2) designing, validating and testing your application, and (3) ensuring your application meets applicable standards, and any other safety, security, regulatory or other requirements.

These resources are subject to change without notice. TI grants you permission to use these resources only for development of an application that uses the TI products described in the resource. Other reproduction and display of these resources is prohibited. No license is granted to any other TI intellectual property right or to any third party intellectual property right. TI disclaims responsibility for, and you will fully indemnify TI and its representatives against, any claims, damages, costs, losses, and liabilities arising out of your use of these resources.

TI's products are provided subject to [TI's Terms of Sale](#) or other applicable terms available either on [ti.com](http://ti.com) or provided in conjunction with such TI products. TI's provision of these resources does not expand or otherwise alter TI's applicable warranties or warranty disclaimers for TI products.

TI objects to and rejects any additional or different terms you may have proposed.

Mailing Address: Texas Instruments, Post Office Box 655303, Dallas, Texas 75265  
Copyright © 2022, Texas Instruments Incorporated