

## TLV170x 2.2V 至 36V 低功耗比较器

### 1 特性

- 电源范围：  
+2.2V 至 +36V 或  $\pm 1.1V$  至  $\pm 18V$
- 低静态电流：  
每个比较器 55 $\mu A$
- 输入共模范围包括两个电源轨
- 低传播延迟：560ns
- 低输入偏移电压：300 $\mu V$
- 集电极开路输出：
  - 最大可高出负电源 36V 且不受电源电压影响
- 工业温度范围：  
-40°C 至 +125°C
- 小型封装：
  - 单通道：SC70-5、SOT-23-5 和 SOT553-5
  - 双通道：VSSOP-8、X2QFN-8
  - 四通道：TSSOP-14

### 2 应用范围

- 过压和欠压检测器
- 窗口比较器
- 过流检测器
- 零交叉检测器
- 针对以下应用的系统监控：
  - 电源
  - 白色家电
  - 工业传感器
  - 汽车
  - 医疗

#### TLV1702 作为窗口比较器

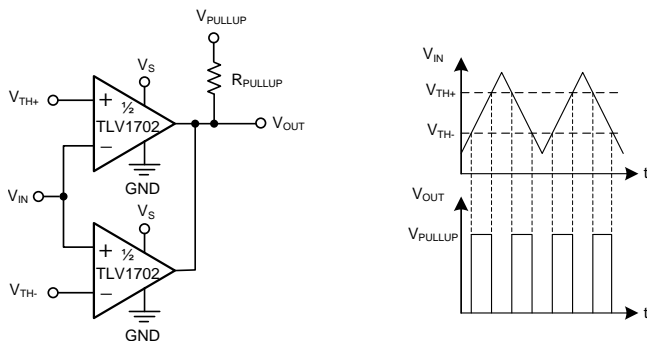

### 3 说明

TLV170x 系列器件提供宽电源范围、轨到轨输入、低静态电流和低传播延迟。所有这些特性均符合行业标准，采用极小封装，借此，这些器件得以成为目前市场上可提供的最佳通用比较器。

集电极开路输出具有能够将输出拉至任意电压轨（最大可高出负电源 +36V）的优势，且不受 TLV170x 电源电压影响。

这些器件均可提供单通道 (TLV1701)、双通道 (TLV1702) 和四通道 (TLV1704) 三种版本。低输入偏移电压、低输入偏置电流、低电源电流和开集配置使得 TLV170x 系列能够灵活处理从简单电压检测到驱动单个继电器的大多数应用。

所有器件的额定工作温度均在扩展的工业温度范围 -40°C 到 +125°C 内。

#### 器件信息(1)

器件型号	封装	封装尺寸 (标称值)
TLV1701	SOT553 (5)	1.20mm × 1.60mm
	SC-70 (5)	1.25mm × 2.00mm
	SOT-23 (5)	1.60mm × 2.90mm
TLV1702	X2QFN (8)	1.50mm × 1.50mm
	VSSOP (8) <sup>(2)</sup>	3.00mm × 3.00mm
TLV1704	TSSOP (14)	4.40mm × 5.00mm

(1) 要了解所有可用封装，请见数据表末尾的封装选项附录。

(2) VSSOP 封装与 MSOP 封装相同。

#### 稳定传播延迟与温度

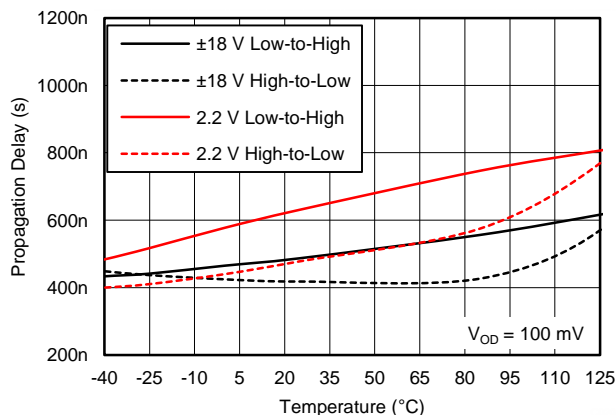

## 目录

<b>1</b>	特性 .....	<b>1</b>	8.3	Feature Description .....	<b>12</b>
<b>2</b>	应用范围 .....	<b>1</b>	8.4	Device Functional Modes .....	<b>12</b>
<b>3</b>	说明 .....	<b>1</b>	<b>9</b>	<b>Applications and Implementation .....</b>	<b>13</b>
<b>4</b>	修订历史记录 .....	<b>2</b>	9.1	Application Information .....	<b>13</b>
<b>5</b>	<b>Device Comparison .....</b>	<b>4</b>	9.2	Typical Application .....	<b>13</b>
<b>6</b>	<b>Pin Configuration and Functions .....</b>	<b>5</b>	<b>10</b>	<b>Power Supply Recommendations .....</b>	<b>14</b>
<b>7</b>	<b>Specifications .....</b>	<b>6</b>	<b>11</b>	<b>Layout .....</b>	<b>15</b>
7.1	Absolute Maximum Ratings .....	<b>6</b>	11.1	Layout Guidelines .....	<b>15</b>
7.2	ESD Ratings .....	<b>6</b>	11.2	Layout Example .....	<b>15</b>
7.3	Recommended Operating Conditions .....	<b>6</b>	<b>12</b>	器件和文档支持 .....	<b>16</b>
7.4	Thermal Information: TLV1701 .....	<b>6</b>	12.1	文档支持 .....	<b>16</b>
7.5	Thermal Information: TLV1702 and TLV1704 .....	<b>7</b>	12.2	相关链接 .....	<b>16</b>
7.6	Electrical Characteristics .....	<b>7</b>	12.3	社区资源 .....	<b>16</b>
7.7	Switching Characteristics .....	<b>7</b>	12.4	商标 .....	<b>16</b>
7.8	Typical Characteristics .....	<b>8</b>	12.5	静电放电警告 .....	<b>16</b>
<b>8</b>	<b>Detailed Description .....</b>	<b>11</b>	12.6	术语表 .....	<b>16</b>
8.1	Overview .....	<b>11</b>	<b>13</b>	机械、封装和可订购信息 .....	<b>16</b>
8.2	Functional Block Diagram .....	<b>11</b>			

## 4 修订历史记录

NOTE: Page numbers for previous revisions may differ from page numbers in the current version.

<b>Changes from Revision C (December 2014) to Revision D</b>	<b>Page</b>
• 已将文档状态从“混合状态”更改为“量产数据” .....	<b>1</b>
• 已将 TLV1702 RUG 封装的状态更改为量产数据 .....	<b>1</b>

<b>Changes from Revision B (October 2014) to Revision C</b>	<b>Page</b>
• TLV1701 DCK 封装已从预览更改为量产数据 .....	<b>1</b>
• Changed Handling Ratings table to ESD Ratings table, and moved storage temperature to Absolute Maximum Ratings table .....	<b>6</b>

<b>Changes from Revision A (September 2014) to Revision B</b>	<b>Page</b>
• 更改了器件信息表中的脚注 2: 已将 TLV1701 添加到可用器件列表中 .....	<b>1</b>
• Added TLV1701 to list of production data packages in footnote for the <i>Pin Configuration and Functions</i> section .....	<b>5</b>
• Added TLV1701 row to $V_{(ESD)}$ parameter in Handling Ratings table .....	<b>6</b>

<b>Changes from Original (December 2013) to Revision A</b>	<b>Page</b>
• 已将文档格式更改为符合最新的数据表标准；添加了新章节并移动了现有章节.....	1
• TLV1704 PW (TSSOP-14) 封装已从预览更改为量产数据.....	1
• 在集电极开路输出特性中添加了分项 .....	1
• 在 <a href="#">说明</a> 部分添加了第二段 .....	1
• 已从 <a href="#">说明</a> 部分中删除封装信息；冗余信息 .....	1
• Changed Related Products table to Device Comparison table, moved from page 1, and added TLV370x family.....	4
• Added TLV1701, TLV1702 RUG, and TLV704 package drawings .....	5
• Added thermal information for TLV1702 RUG, TLV1704 PW, and all TLV1701 packages .....	6
• Moved switching characteristics parameters from Electrical Characteristics table to new <a href="#">Switching Characteristics</a> table ..	7
• Changed all typical values in <a href="#">Switching Characteristics</a> table.....	7
• Changed title for <a href="#">Figure 1</a> .....	8
• Changed <a href="#">Figure 8</a> .....	8
• Changed <a href="#">Figure 9</a> .....	8
• Changed <a href="#">Figure 10</a> .....	8
• Changed <a href="#">Figure 11</a> .....	8
• Changed <a href="#">Figure 12</a> .....	8
• Changed <a href="#">Figure 13</a> .....	9
• Changed <a href="#">Figure 14</a> .....	9
• Changed <a href="#">Application Information</a> and moved section .....	13
• Deleted <a href="#">Application Examples</a> section .....	13

## 5 Device Comparison

DEVICE	FEATURES
<a href="#">TLV3201</a>	40-ns, 40- $\mu$ A, push-pull comparator
<a href="#">TLV3202</a>	
<a href="#">TLV3501</a>	4.5-ns, rail-to-rail, push-pull, high-speed comparator
<a href="#">TLV3502</a>	
<a href="#">TLV3401</a>	Nanopower open-drain output comparator
<a href="#">TLV3402</a>	
<a href="#">TLV3404</a>	
<a href="#">TLV3701</a>	Nanopower push-pull output comparator
<a href="#">TLV3702</a>	
<a href="#">TLV3704</a>	
<a href="#">REF3325</a>	3.9- $\mu$ A, SC70-3 voltage reference
<a href="#">REF3330</a>	
<a href="#">REF3333</a>	

## 6 Pin Configuration and Functions

**TLV1701**  
DBV (SOT-23-5), DCK (SC70-5), DRL (SOT553-5) Packages  
Top View

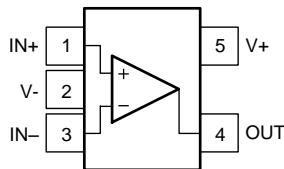

**TLV1702**  
RUG (X2QFN-8) Package  
Top View

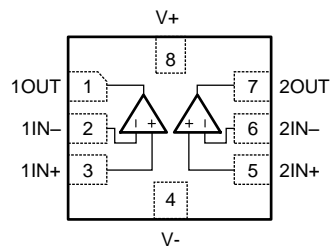

**TLV1702**  
DGK (VSSOP-8) Package  
Top View

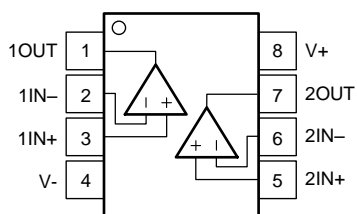

**TLV1704**  
PW (TSSOP-14) Package  
Top View

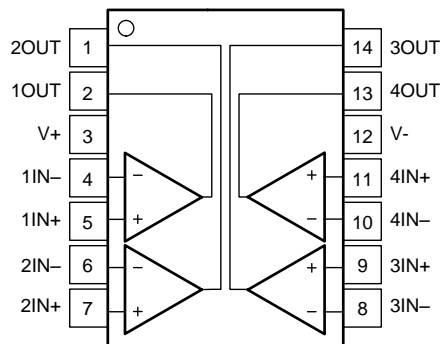

### Pin Functions

NAME	PIN NO.			I/O	DESCRIPTION
	TLV1701 DBV, DCK, DRL	TLV1702 DGK, RUG	TLV1704 PW		
IN+	1	—	—	I	Noninverting input
1IN+	—	3	5	I	Noninverting input, channel 1
2IN+	—	5	7	I	Noninverting input, channel 2
3IN+	—	—	9	I	Noninverting input, channel 3
4IN+	—	—	11	I	Noninverting input, channel 4
IN-	3	—	—	I	Inverting input
1IN-	—	2	4	I	Inverting input, channel 1
2IN-	—	6	6	I	Inverting input, channel 2
3IN-	—	—	8	I	Inverting input, channel 3
4IN-	—	—	10	I	Inverting input, channel 4
OUT	4	—	—	O	Output
1OUT	—	1	2	O	Output, channel 1
2OUT	—	7	1	O	Output, channel 2
3OUT	—	—	14	O	Output, channel 3
4OUT	—	—	13	O	Output, channel 4
V+	5	8	3	—	Positive (highest) power supply
V-	2	4	12	—	Negative (lowest) power supply

## 7 Specifications

### 7.1 Absolute Maximum Ratings<sup>(1)</sup>

over operating free-air temperature range (unless otherwise noted)

		MIN	MAX	UNIT
Supply voltage		+40 (±20)		V
Signal input pins	Voltage <sup>(2)</sup>	(V <sub>S-</sub> ) – 0.5	(V <sub>S+</sub> ) + 0.5	V
	Current <sup>(2)</sup>	±10		mA
Output short-circuit <sup>(3)</sup>		Continuous		mA
Operating temperature range		–55	+150	°C
Junction temperature, T <sub>J</sub>		150		°C
Storage temperature, T <sub>stg</sub>		–65	+150	°C

- Stresses beyond those listed under absolute maximum ratings may cause permanent damage to the device. These are stress ratings only, and functional operation of the device at these or any other conditions beyond those indicated under recommended operating conditions is not implied. Exposure to absolute-maximum-rated conditions for extended periods may affect device reliability.
- Input pins are diode-clamped to the power-supply rails. Input signals that can swing more than 0.5 V beyond the supply rails must be current limited to 10 mA or less.
- Short-circuit to ground; one comparator per package.

### 7.2 ESD Ratings

			VALUE	UNIT
TLV1701 and TLV1702				
V <sub>(ESD)</sub>	Electrostatic discharge	Human-body model (HBM), per ANSI/ESDA/JEDEC JS-001 <sup>(1)</sup>	±2000	V
		Charged-device model (CDM), per JEDEC specification JESD22-C101 <sup>(2)</sup>	±1500	
TLV1704				
V <sub>(ESD)</sub>	Electrostatic discharge	Human-body model (HBM), per ANSI/ESDA/JEDEC JS-001 <sup>(1)</sup>	±1000	V
		Charged-device model (CDM), per JEDEC specification JESD22-C101 <sup>(2)</sup>	±1500	

- JEDEC document JEP155 states that 500-V HBM allows safe manufacturing with a standard ESD control process.
- JEDEC document JEP157 states that 250-V CDM allows safe manufacturing with a standard ESD control process.

### 7.3 Recommended Operating Conditions

over operating free-air temperature range (unless otherwise noted)

	MIN	NOM	MAX	UNIT
Supply voltage V <sub>S</sub> = (V <sub>S+</sub> ) – (V <sub>S-</sub> )	2.2 (±1.1)		36 (±18)	V
Specified temperature	–40		125	°C

### 7.4 Thermal Information: TLV1701

THERMAL METRIC <sup>(1)</sup>	TLV1701			UNIT
	DRL (SOT553)	DCK (SC70)	DBV (SOT23)	
	5 PINS	5 PINS	5 PINS	
R <sub>θJA</sub> Junction-to-ambient thermal resistance	271.5	283.6	233.1	°C/W
R <sub>θJC(top)</sub> Junction-to-case (top) thermal resistance	115.6	94.1	156.4	°C/W
R <sub>θJB</sub> Junction-to-board thermal resistance	89.7	61.3	60.6	°C/W
ψ <sub>JT</sub> Junction-to-top characterization parameter	17.6	1.9	35.7	°C/W
ψ <sub>JB</sub> Junction-to-board characterization parameter	89.2	60.5	59.7	°C/W
R <sub>θJC(bot)</sub> Junction-to-case (bottom) thermal resistance	N/A	N/A	N/A	°C/W

- For more information about traditional and new thermal metrics, see the *Semiconductor and IC Package Thermal Metrics* application report, [SPRA953](#).

## 7.5 Thermal Information: TLV1702 and TLV1704

THERMAL METRIC <sup>(1)</sup>		TLV1702		TLV1704	UNIT
		RUG (QFN)	DGK (VSSOP)	PW (TSSOP)	
		8 PINS	8 PINS	14 PINS	
$\theta_{JA}$	Junction-to-ambient thermal resistance	205.6	199	128.1	°C/W
$\theta_{JCTop}$	Junction-to-case (top) thermal resistance	77.1	89.5	56.5	°C/W
$\theta_{JB}$	Junction-to-board thermal resistance	107.0	120.4	69.9	°C/W
$\psi_{JT}$	Junction-to-top characterization parameter	2.0	22.0	9.1	°C/W
$\psi_{JB}$	Junction-to-board characterization parameter	107.0	118.7	69.3	°C/W
$\theta_{JCbott}$	Junction-to-case (bottom) thermal resistance	N/A	N/A	N/A	°C/W

(1) For more information about traditional and new thermal metrics, see the *Semiconductor and IC Package Thermal Metrics* application report, [SPRA953](#).

## 7.6 Electrical Characteristics

at  $T_A = +25^\circ\text{C}$ ,  $V_S = +2.2\text{ V to }+36\text{ V}$ ,  $C_L = 15\text{ pF}$ ,  $R_{PULLUP} = 5.1\text{ k}\Omega$ ,  $V_{CM} = V_S / 2$ , and  $V_S = V_{PULLUP}$  (unless otherwise noted)

PARAMETER		TEST CONDITIONS	MIN	TYP	MAX	UNIT
<b>OFFSET VOLTAGE</b>						
$V_{OS}$	Input offset voltage	$T_A = 25^\circ\text{C}$ , $V_S = 2.2\text{ V}$		$\pm 0.5$	$\pm 3.5$	mV
		$T_A = 25^\circ\text{C}$ , $V_S = 36\text{ V}$		$\pm 0.3$	$\pm 2.5$	mV
		$T_A = -40^\circ\text{C to }+125^\circ\text{C}$			$\pm 5.5$	mV
$dV_{OS}/dT$	Input offset voltage drift	$T_A = -40^\circ\text{C to }+125^\circ\text{C}$		$\pm 4$	$\pm 20$	$\mu\text{V}/^\circ\text{C}$
PSRR	Power-supply rejection ratio			15	100	$\mu\text{V}/\text{V}$
		$T_A = -40^\circ\text{C to }+125^\circ\text{C}$		20		$\mu\text{V}/\text{V}$
<b>INPUT VOLTAGE RANGE</b>						
$V_{CM}$	Common-mode voltage range	$T_A = -40^\circ\text{C to }+125^\circ\text{C}$	(V-)		(V+)	V
<b>INPUT BIAS CURRENT</b>						
$I_B$	Input bias current			5	15	nA
		$T_A = -40^\circ\text{C to }+125^\circ\text{C}$			20	nA
$I_{OS}$	Input offset current			0.5		nA
$C_{LOAD}$	Capacitive load drive		See <a href="#">Typical Characteristics</a>			
<b>OUTPUT</b>						
$V_O$	Voltage output swing from rail	$I_O \leq 4\text{ mA}$ , input overdrive = 100 mV, $V_S = 36\text{ V}$			900	mV
		$I_O = 0\text{ mA}$ , input overdrive = 100 mV, $V_S = 36\text{ V}$			600	mV
$I_{SC}$	Short circuit sink current			20		mA
	Output leakage current	$V_{IN+} > V_{IN-}$		70		nA
<b>POWER SUPPLY</b>						
$V_S$	Specified voltage range		2.2		36	V
$I_Q$	Quiescent current (per channel)	$I_O = 0\text{ A}$		55	75	$\mu\text{A}$
		$I_O = 0\text{ A}$ , $T_A = -40^\circ\text{C to }+125^\circ\text{C}$			100	$\mu\text{A}$

## 7.7 Switching Characteristics

at  $T_A = +25^\circ\text{C}$ ,  $V_S = +2.2\text{ V to }+36\text{ V}$ ,  $C_L = 15\text{ pF}$ ,  $R_{PULLUP} = 5.1\text{ k}\Omega$ ,  $V_{CM} = V_S / 2$ , and  $V_S = V_{PULLUP}$  (unless otherwise noted)

PARAMETER		TEST CONDITIONS	MIN	TYP	MAX	UNIT
$t_{pHL}$	Propagation delay time, high-to-low	Input overdrive = 100 mV		460		ns
$t_{pLH}$	Propagation delay time, low-to-high	Input overdrive = 100 mV		560		ns
$t_R$	Rise time	Input overdrive = 100 mV		365		ns
$t_F$	Fall time	Input overdrive = 100 mV		240		ns

### 7.8 Typical Characteristics

at  $T_A = +25^\circ\text{C}$ ,  $V_S = +5\text{ V}$ ,  $R_{\text{PULLUP}} = 5.1\text{ k}\Omega$ , and input overdrive = 100 mV (unless otherwise noted)

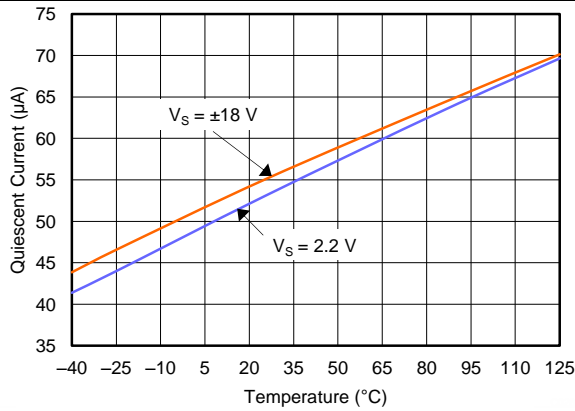

Figure 1. Quiescent Current vs Temperature

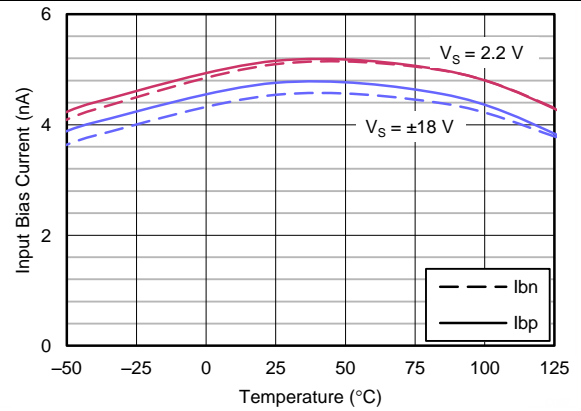

Figure 2. Input Bias Current vs Temperature

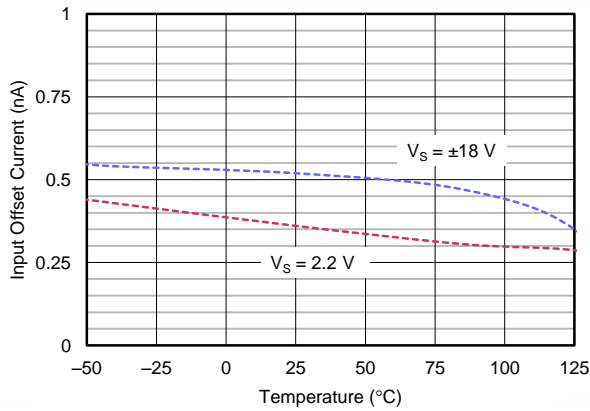

Figure 3. Input Offset Current vs Temperature

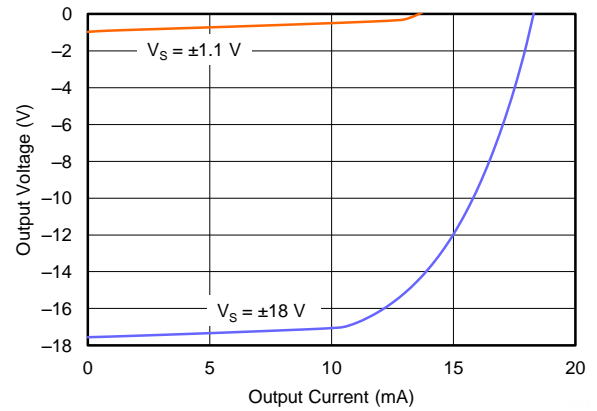

Figure 4. Output Voltage vs Output Current

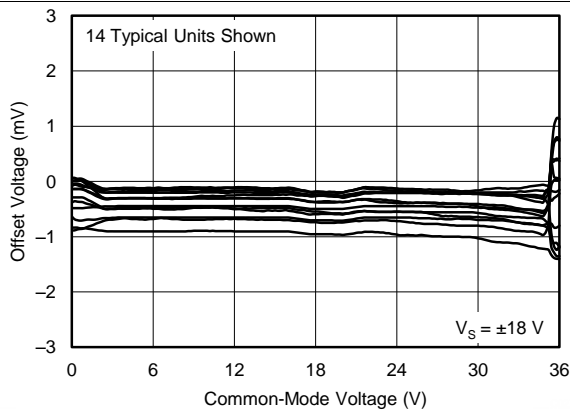

Figure 5. Offset Voltage vs Common-Mode Voltage

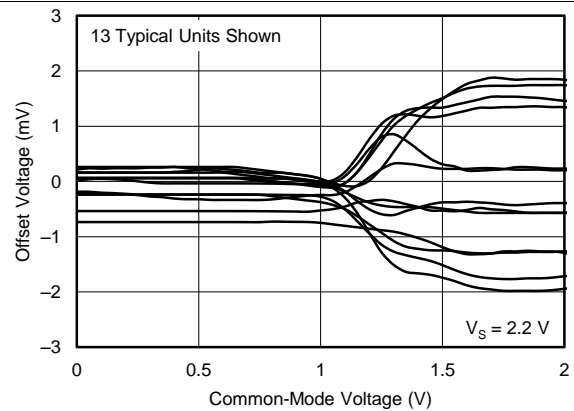

Figure 6. Offset Voltage vs Common-Mode Voltage

Typical Characteristics (continued)

at  $T_A = +25^\circ\text{C}$ ,  $V_S = +5\text{ V}$ ,  $R_{\text{PULLUP}} = 5.1\text{ k}\Omega$ , and input overdrive = 100 mV (unless otherwise noted)

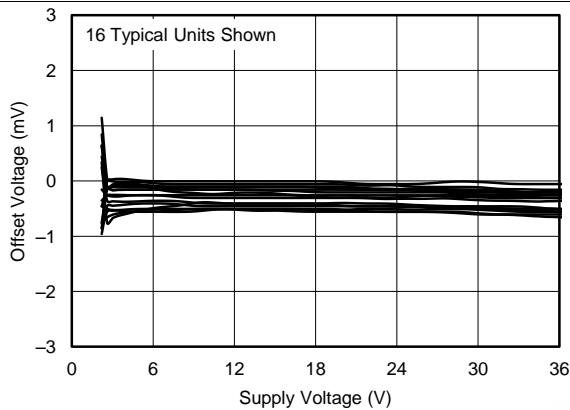

Figure 7. Offset Voltage vs Supply Voltage

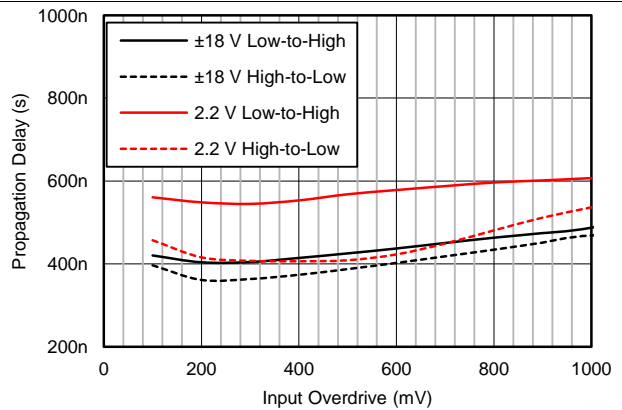

Figure 8. Propagation Delay vs Input Overdrive

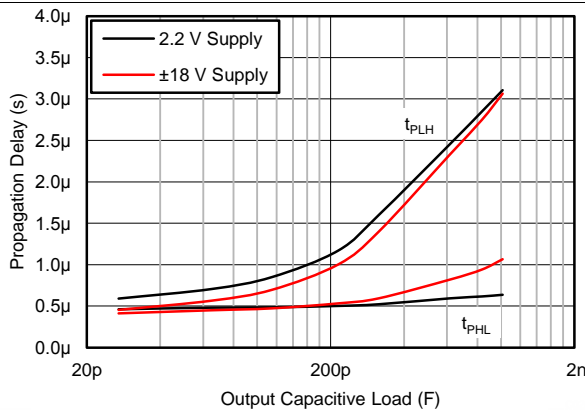

Figure 9. Propagation Delay vs Capacitive Load

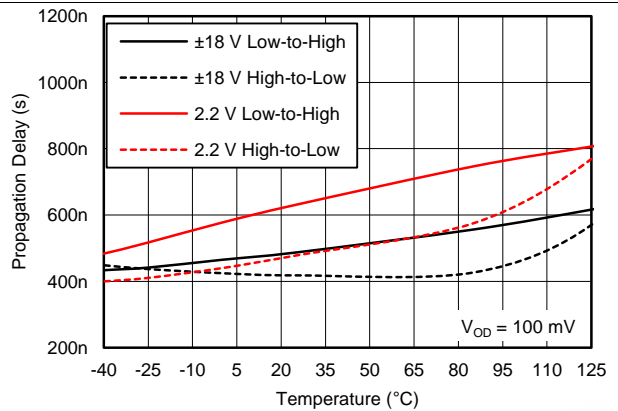

Figure 10. Propagation Delay vs Temperature

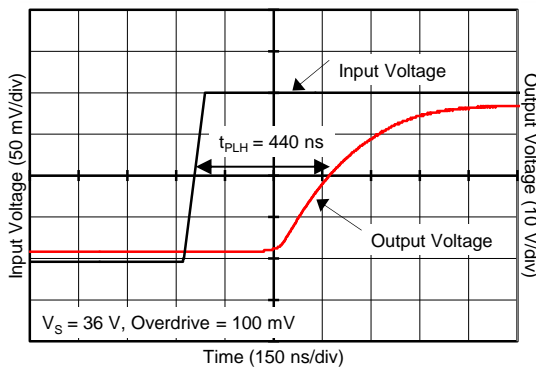

Figure 11. Propagation Delay ( $T_{\text{PLH}}$ )

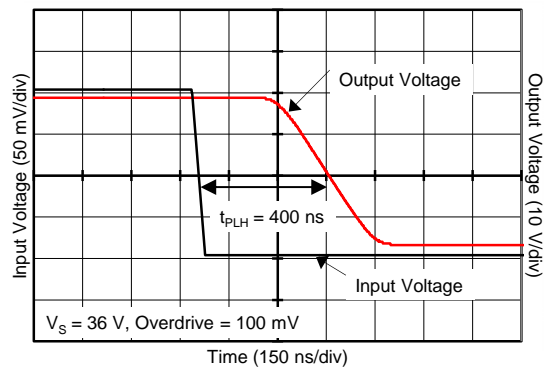

Figure 12. Propagation Delay ( $T_{\text{PHL}}$ )

Typical Characteristics (continued)

at  $T_A = +25^\circ\text{C}$ ,  $V_S = +5\text{ V}$ ,  $R_{\text{PULLUP}} = 5.1\text{ k}\Omega$ , and input overdrive = 100 mV (unless otherwise noted)

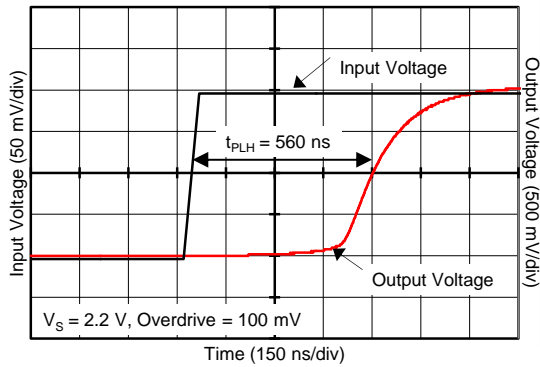

Figure 13. Propagation Delay ( $T_{\text{pLH}}$ )



Figure 14. Propagation Delay ( $T_{\text{pHL}}$ )

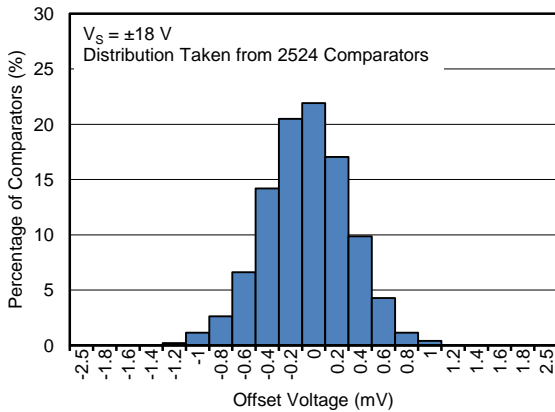

Figure 15. Offset Voltage Production Distribution

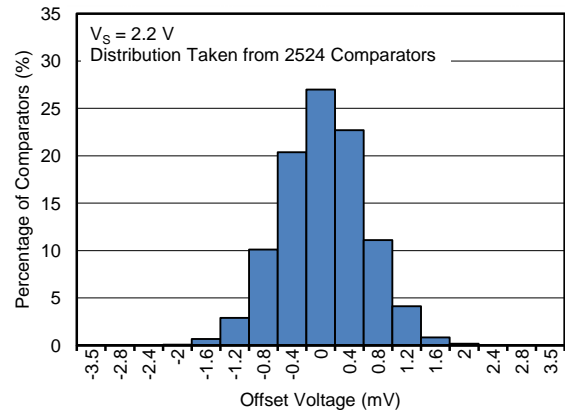

Figure 16. Offset Voltage Production Distribution

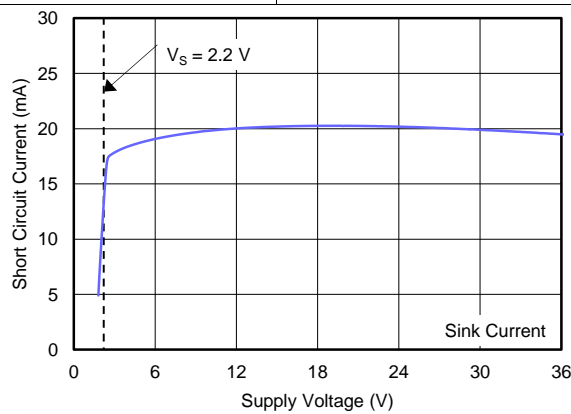

Figure 17. Short-Circuit Current vs Supply Voltage

## 8 Detailed Description

### 8.1 Overview

The TLV170x comparators features rail-to-rail input and output on supply voltages as high as 36 V. The rail-to-rail input stage enables detection of signals close to the supply and ground. The open collector configuration allows the device to be used in wired-OR configurations, such as a window comparator. A low supply current of 55  $\mu\text{A}$  per channel with small, space-saving packages, makes these comparators versatile for use in a wide range of applications, from portable to industrial.

### 8.2 Functional Block Diagram

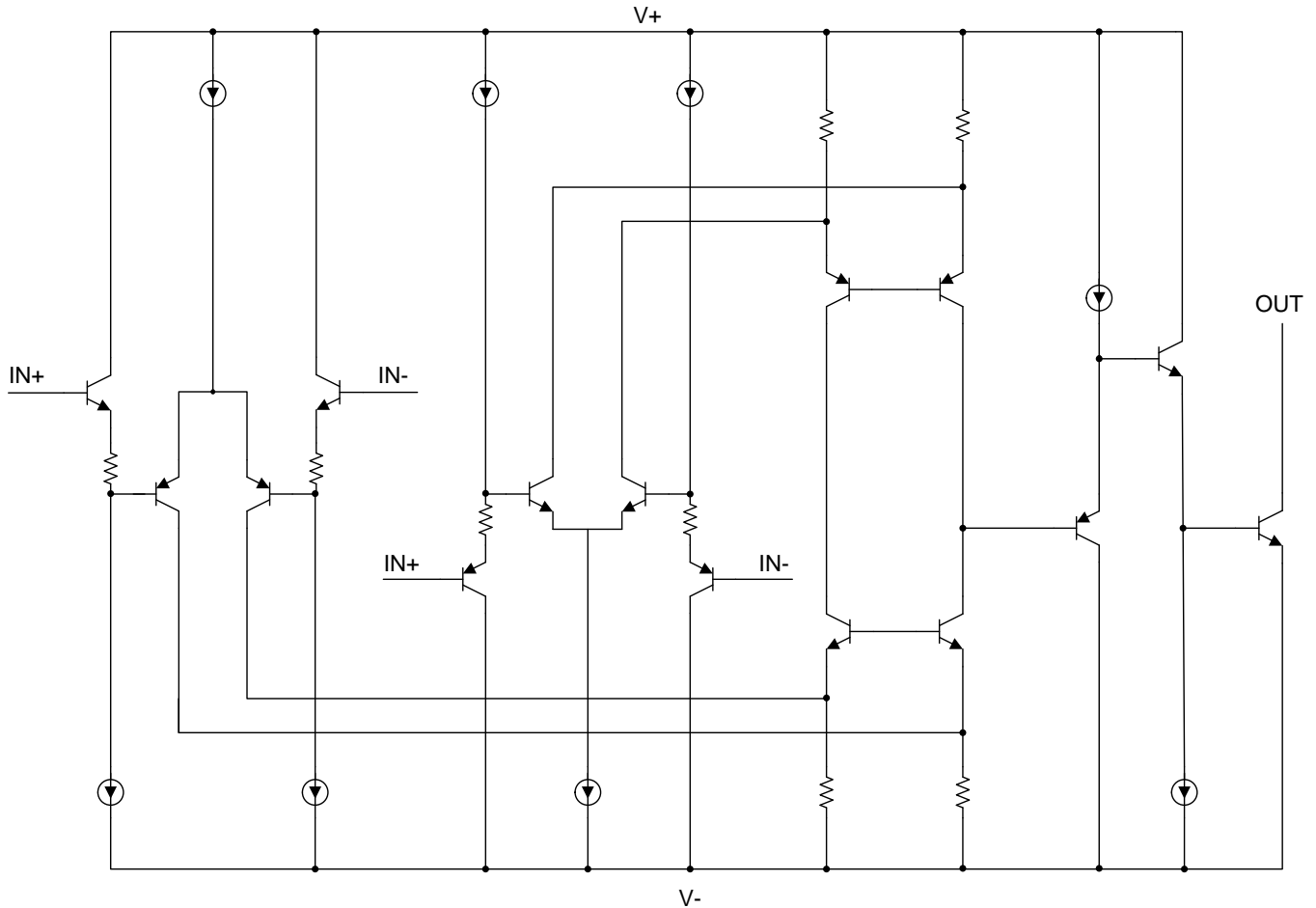

## 8.3 Feature Description

### 8.3.1 Comparator Inputs

The TLV170x are rail-to-rail input comparators, with an input common-mode range that includes the supply rails. The TLV170x is designed to prevent phase inversion when the input pins exceed the supply voltage. Figure 18 shows the TLV170x response when input voltages exceed the supply, resulting in no phase inversion.

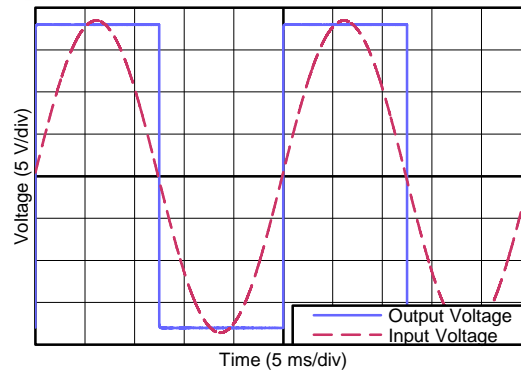
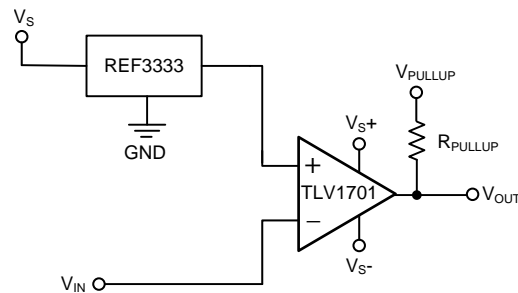

**Figure 18. No Phase Inversion: Comparator Response to Input Voltage (Propagation Delay Included)**

## 8.4 Device Functional Modes

### 8.4.1 Setting Reference Voltage

Using a stable reference is important when setting the transition point for the TLV170x. The REF3333, as shown in Figure 19, provides a 3.3-V reference voltage with low drift and only 3.9  $\mu\text{A}$  of quiescent current.



**Figure 19. Reference Voltage for the TLV170x**

## 9 Applications and Implementation

### NOTE

Information in the following applications sections is not part of the TI component specification, and TI does not warrant its accuracy or completeness. TI's customers are responsible for determining suitability of components for their purposes. Customers should validate and test their design implementation to confirm system functionality.

### 9.1 Application Information

The TLV170x can be used in a wide variety of applications, such as zero crossing detectors, window comparators, over and undervoltage detectors, and high-side voltage sense circuits.

### 9.2 Typical Application

Comparators are used to differentiate between two different signal levels. For example, a comparator differentiates between an overtemperature and normal-temperature condition. However, noise or signal variation at the comparison threshold causes multiple transitions. This application example sets upper and lower hysteresis thresholds to eliminate the multiple transitions caused by noise.

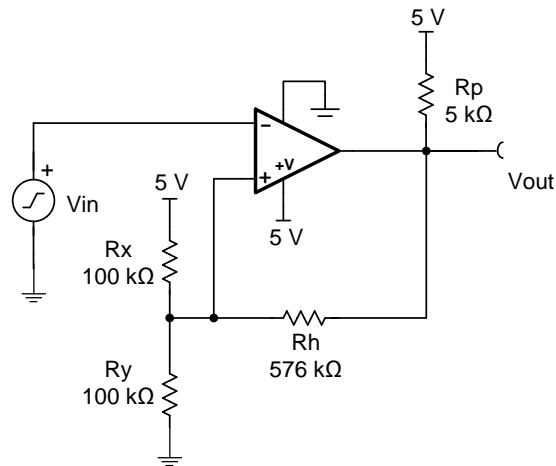

**Figure 20. Comparator Schematic with Hysteresis**

#### 9.2.1 Design Requirements

The design requirements are as follows:

- Supply voltage: 5 V
- Input: 0 V to 5 V
- Lower threshold ( $V_L$ ) = 2.3 V  $\pm$ 0.1 V
- Upper threshold ( $V_H$ ) = 2.7 V  $\pm$ 0.1 V
- $V_H - V_L = 2.4$  V  $\pm$ 0.1 V
- Low power consumption

## Typical Application (continued)

### 9.2.2 Detailed Design Procedure

Make a small change to the comparator circuit to add hysteresis. Hysteresis uses two different threshold voltages to avoid the multiple transitions introduced in the previous circuit. The input signal must exceed the upper threshold (VH) to transition low, or below the lower threshold (VL) to transition high.

Figure 20 illustrates hysteresis on a comparator. Resistor Rh sets the hysteresis level. An open-collector output stage requires a pullup resistor (Rp). The pullup resistor creates a voltage divider at the comparator output that introduces an error when the output is at logic high. This error can be minimized if  $R_h > 100R_p$ .

When the output is at a logic high (5 V), Rh is in parallel with Rx (ignoring Rp). This configuration drives more current into Ry, and raises the threshold voltage (VH) to 2.7 V. The input signal must drive above  $V_H = 2.7$  V to cause the output to transition to logic low (0 V).

When the output is at logic low (0 V), Rh is in parallel with Ry. This configuration reduces the current into Ry, and reduces the threshold voltage to 2.3 V. The input signal must drive below  $V_L = 2.3$  V to cause the output to transition to logic high (5 V).

For more details on this design and other alternative devices that can be used in place of the TLV1702, refer to Precision Design TIPD144, *Comparator with Hysteresis Reference Design*.

### 9.2.3 Application Curve

Figure 21 shows the upper and lower thresholds for hysteresis. The upper threshold is 2.76 V and the lower threshold is 2.34 V, both of which are close to the design target.

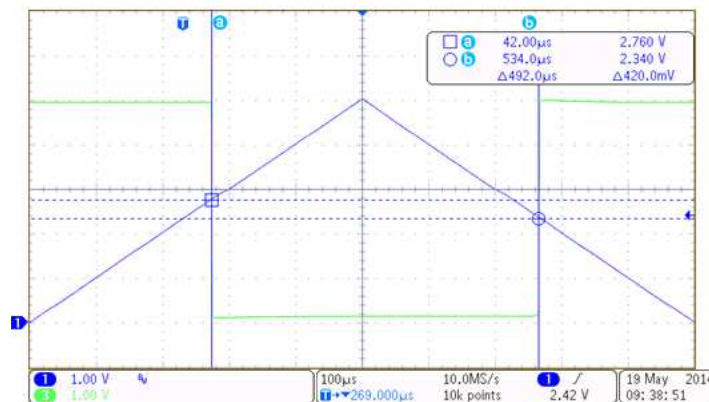

Figure 21. TLV1701 Upper and Lower Threshold with Hysteresis

## 10 Power Supply Recommendations

The TLV170x is specified for operation from 2.2 V to 36 V ( $\pm 1.1$  to  $\pm 18$  V); many specifications apply from  $-40^\circ\text{C}$  to  $+125^\circ\text{C}$ . Parameters that can exhibit significant variance with regard to operating voltage or temperature are presented in the [Typical Characteristics](#) section.

### CAUTION

Supply voltages larger than 40 V can permanently damage the device; see the [Absolute Maximum Ratings](#).

Place 0.1- $\mu\text{F}$  bypass capacitors close to the power-supply pins to reduce errors coupling in from noisy or high-impedance power supplies. For more detailed information on bypass capacitor placement; see the [Layout Guidelines](#) section.

## 11 Layout

### 11.1 Layout Guidelines

Comparators are very sensitive to input noise. For best results, maintain the following layout guidelines:

- Use a printed circuit board (PCB) with a good, unbroken low-inductance ground plane. Proper grounding (use of ground plane) helps maintain specified performance of the TLV170x.
- To minimize supply noise, place a decoupling capacitor (0.1- $\mu$ F ceramic, surface-mount capacitor) as close as possible to  $V_S$  as shown in Figure 22.
- On the inputs and the output, keep lead lengths as short as possible to avoid unwanted parasitic feedback around the comparator. Keep inputs away from the output.
- Solder the device directly to the PCB rather than using a socket.
- For slow-moving input signals, take care to prevent parasitic feedback. A small capacitor (1000 pF or less) placed between the inputs can help eliminate oscillations in the transition region. This capacitor causes some degradation to propagation delay when the impedance is low. Run the topside ground plane between the output and inputs.
- Run the ground pin ground trace under the device up to the bypass capacitor, shielding the inputs from the outputs.

### 11.2 Layout Example

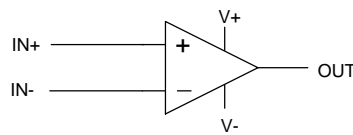

(Schematic Representation)

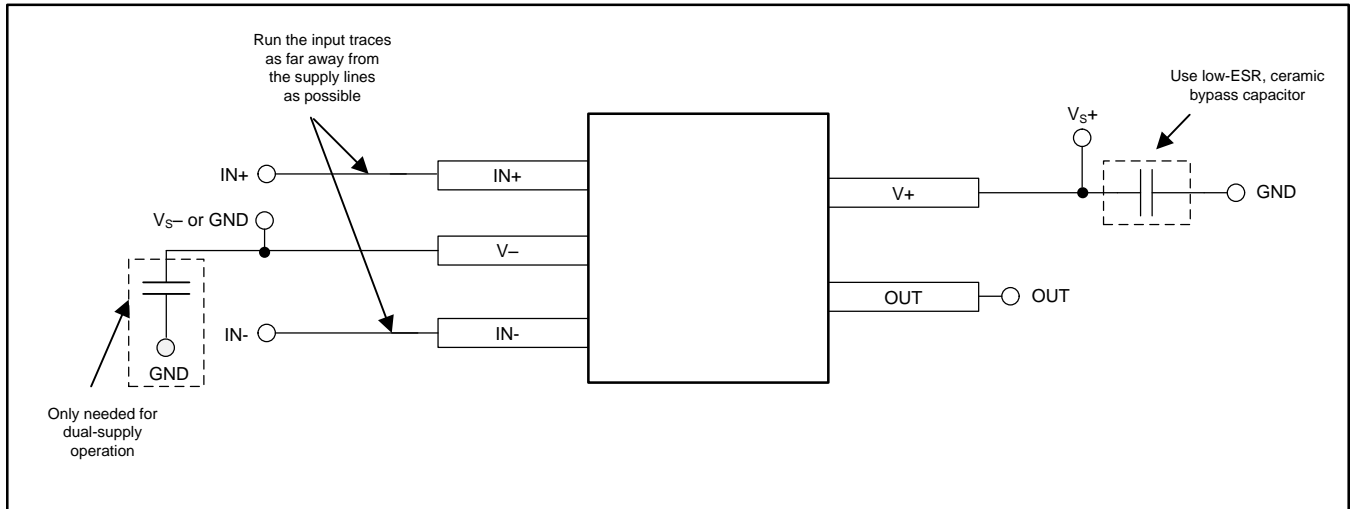

**Figure 22. Comparator Board Layout**

## 12 器件和文档支持

### 12.1 文档支持

#### 12.1.1 相关文档

[TIDU020](#) — 高精度设计，采用滞后参考设计的比较器。

[SBOS392](#) — REF3333 数据手册

### 12.2 相关链接

**表 1** 列出了快速访问链接。范围包括技术文档、支持与社区资源、工具和软件，并且可以快速访问样片或购买链接。

表 1. 相关链接

器件	产品文件夹	样片与购买	技术文档	工具与软件	支持与社区
TLV1701	<a href="#">请单击此处</a>	<a href="#">请单击此处</a>	<a href="#">请单击此处</a>	<a href="#">请单击此处</a>	<a href="#">请单击此处</a>
TLV1702	<a href="#">请单击此处</a>	<a href="#">请单击此处</a>	<a href="#">请单击此处</a>	<a href="#">请单击此处</a>	<a href="#">请单击此处</a>
TLV1704	<a href="#">请单击此处</a>	<a href="#">请单击此处</a>	<a href="#">请单击此处</a>	<a href="#">请单击此处</a>	<a href="#">请单击此处</a>

### 12.3 社区资源

The following links connect to TI community resources. Linked contents are provided "AS IS" by the respective contributors. They do not constitute TI specifications and do not necessarily reflect TI's views; see TI's [Terms of Use](#).

**TI E2E™ Online Community** *TI's Engineer-to-Engineer (E2E) Community*. Created to foster collaboration among engineers. At e2e.ti.com, you can ask questions, share knowledge, explore ideas and help solve problems with fellow engineers.

**Design Support** *TI's Design Support* Quickly find helpful E2E forums along with design support tools and contact information for technical support.

### 12.4 商标

E2E is a trademark of Texas Instruments.

All other trademarks are the property of their respective owners.

### 12.5 静电放电警告



ESD 可能会损坏该集成电路。德州仪器 (TI) 建议通过适当的预防措施处理所有集成电路。如果不遵守正确的处理措施和安装程序，可能会损坏集成电路。

ESD 的损坏小至导致微小的性能降级，大至整个器件故障。精密的集成电路可能更容易受到损坏，这是因为非常细微的参数更改都可能会导致器件与其发布的规格不相符。

### 12.6 术语表

[SLYZ022](#) — TI 术语表。

这份术语表列出并解释术语、首字母缩略词和定义。

## 13 机械、封装和可订购信息

以下页中包括机械、封装和可订购信息。 这些信息是针对指定器件可提供的最新数据。 这些数据会在无通知且不对本文档进行修订的情况下发生改变。 欲获得该数据表的浏览器版本，请查阅左侧的导航栏。

**PACKAGING INFORMATION**

Orderable Device	Status (1)	Package Type	Package Drawing	Pins	Package Qty	Eco Plan (2)	Lead finish/ Ball material (6)	MSL Peak Temp (3)	Op Temp (°C)	Device Marking (4/5)	Samples
TLV1701AIDBVR	ACTIVE	SOT-23	DBV	5	3000	RoHS & Green	NIPDAU	Level-2-260C-1 YEAR	-40 to 125	ZAYF	<a href="#">Samples</a>
TLV1701AIDBVT	ACTIVE	SOT-23	DBV	5	250	RoHS & Green	NIPDAU	Level-2-260C-1 YEAR	-40 to 125	ZAYF	<a href="#">Samples</a>
TLV1701AIDCKR	ACTIVE	SC70	DCK	5	3000	RoHS & Green	NIPDAU	Level-2-260C-1 YEAR	-40 to 125	SIR	<a href="#">Samples</a>
TLV1701AIDCKT	ACTIVE	SC70	DCK	5	250	RoHS & Green	NIPDAU	Level-2-260C-1 YEAR	-40 to 125	SIR	<a href="#">Samples</a>
TLV1701AIDRLR	ACTIVE	SOT-5X3	DRL	5	4000	RoHS & Green	NIPDAUAG	Level-1-260C-UNLIM	-40 to 125	SIS	<a href="#">Samples</a>
TLV1701AIDRLT	ACTIVE	SOT-5X3	DRL	5	250	RoHS & Green	NIPDAUAG	Level-1-260C-UNLIM	-40 to 125	SIS	<a href="#">Samples</a>
TLV1702AIDGK	ACTIVE	VSSOP	DGK	8	80	RoHS & Green	NIPDAUAG	Level-1-260C-UNLIM	-40 to 125	1702	<a href="#">Samples</a>
TLV1702AIDGKR	ACTIVE	VSSOP	DGK	8	2500	RoHS & Green	NIPDAUAG	Level-1-260C-UNLIM	-40 to 125	1702	<a href="#">Samples</a>
TLV1702AIRUGR	ACTIVE	X2QFN	RUG	8	3000	RoHS & Green	Call TI   NIPDAUAG	Level-1-260C-UNLIM	-40 to 125	FC	<a href="#">Samples</a>
TLV1704AIPW	ACTIVE	TSSOP	PW	14	90	RoHS & Green	NIPDAU	Level-2-260C-1 YEAR	-40 to 125	TL1704	<a href="#">Samples</a>
TLV1704AIPWR	ACTIVE	TSSOP	PW	14	2000	RoHS & Green	NIPDAU	Level-2-260C-1 YEAR	-40 to 125	TL1704	<a href="#">Samples</a>

(1) The marketing status values are defined as follows:

**ACTIVE:** Product device recommended for new designs.

**LIFEBUY:** TI has announced that the device will be discontinued, and a lifetime-buy period is in effect.

**NRND:** Not recommended for new designs. Device is in production to support existing customers, but TI does not recommend using this part in a new design.

**PREVIEW:** Device has been announced but is not in production. Samples may or may not be available.

**OBSOLETE:** TI has discontinued the production of the device.

(2) **RoHS:** TI defines "RoHS" to mean semiconductor products that are compliant with the current EU RoHS requirements for all 10 RoHS substances, including the requirement that RoHS substance do not exceed 0.1% by weight in homogeneous materials. Where designed to be soldered at high temperatures, "RoHS" products are suitable for use in specified lead-free processes. TI may reference these types of products as "Pb-Free".

**RoHS Exempt:** TI defines "RoHS Exempt" to mean products that contain lead but are compliant with EU RoHS pursuant to a specific EU RoHS exemption.

**Green:** TI defines "Green" to mean the content of Chlorine (Cl) and Bromine (Br) based flame retardants meet JS709B low halogen requirements of <=1000ppm threshold. Antimony trioxide based flame retardants must also meet the <=1000ppm threshold requirement.

(3) MSL, Peak Temp. - The Moisture Sensitivity Level rating according to the JEDEC industry standard classifications, and peak solder temperature.

(4) There may be additional marking, which relates to the logo, the lot trace code information, or the environmental category on the device.

(5) Multiple Device Markings will be inside parentheses. Only one Device Marking contained in parentheses and separated by a "~" will appear on a device. If a line is indented then it is a continuation of the previous line and the two combined represent the entire Device Marking for that device.

(6) Lead finish/Ball material - Orderable Devices may have multiple material finish options. Finish options are separated by a vertical ruled line. Lead finish/Ball material values may wrap to two lines if the finish value exceeds the maximum column width.

**Important Information and Disclaimer:**The information provided on this page represents TI's knowledge and belief as of the date that it is provided. TI bases its knowledge and belief on information provided by third parties, and makes no representation or warranty as to the accuracy of such information. Efforts are underway to better integrate information from third parties. TI has taken and continues to take reasonable steps to provide representative and accurate information but may not have conducted destructive testing or chemical analysis on incoming materials and chemicals. TI and TI suppliers consider certain information to be proprietary, and thus CAS numbers and other limited information may not be available for release.

In no event shall TI's liability arising out of such information exceed the total purchase price of the TI part(s) at issue in this document sold by TI to Customer on an annual basis.

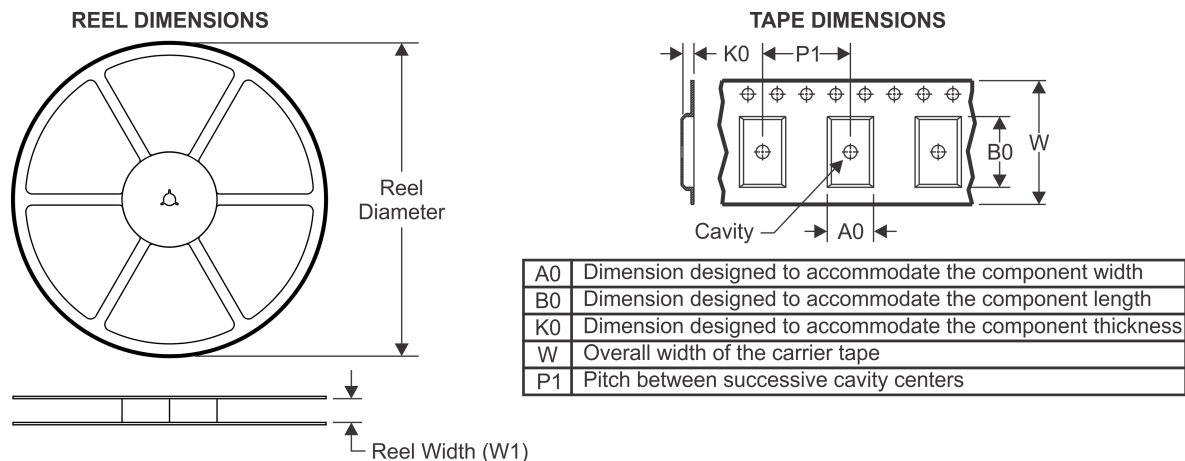
**TAPE AND REEL INFORMATION**

**QUADRANT ASSIGNMENTS FOR PIN 1 ORIENTATION IN TAPE**



\*All dimensions are nominal

Device	Package Type	Package Drawing	Pins	SPQ	Reel Diameter (mm)	Reel Width W1 (mm)	A0 (mm)	B0 (mm)	K0 (mm)	P1 (mm)	W (mm)	Pin1 Quadrant
TLV1701AIDBVR	SOT-23	DBV	5	3000	178.0	9.0	3.23	3.17	1.37	4.0	8.0	Q3
TLV1701AIDBVT	SOT-23	DBV	5	250	178.0	9.0	3.23	3.17	1.37	4.0	8.0	Q3
TLV1701AIDCKR	SC70	DCK	5	3000	178.0	9.0	2.4	2.5	1.2	4.0	8.0	Q3
TLV1701AIDCKT	SC70	DCK	5	250	178.0	9.0	2.4	2.5	1.2	4.0	8.0	Q3
TLV1701AIDRLR	SOT-5X3	DRL	5	4000	180.0	8.4	1.98	1.78	0.69	4.0	8.0	Q3
TLV1701AIDRLT	SOT-5X3	DRL	5	250	180.0	8.4	1.98	1.78	0.69	4.0	8.0	Q3
TLV1702AIDGKR	VSSOP	DGK	8	2500	330.0	12.4	5.3	3.4	1.4	8.0	12.0	Q1
TLV1702AIRUGR	X2QFN	RUG	8	3000	180.0	8.4	1.6	1.6	0.66	4.0	8.0	Q2
TLV1704AIPWR	TSSOP	PW	14	2000	330.0	12.4	6.9	5.6	1.6	8.0	12.0	Q1

**TAPE AND REEL BOX DIMENSIONS**

\*All dimensions are nominal

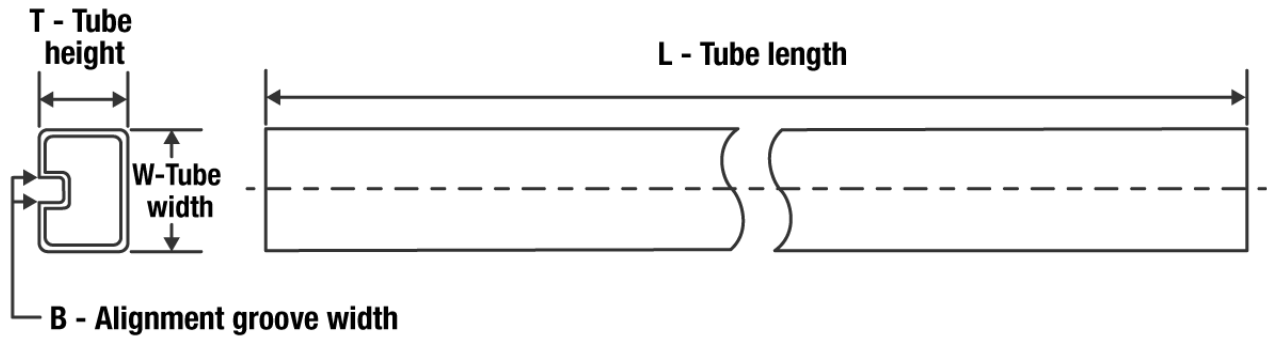
Device	Package Type	Package Drawing	Pins	SPQ	Length (mm)	Width (mm)	Height (mm)
TLV1701AIDBVR	SOT-23	DBV	5	3000	180.0	180.0	18.0
TLV1701AIDBVT	SOT-23	DBV	5	250	180.0	180.0	18.0
TLV1701AIDCKR	SC70	DCK	5	3000	190.0	190.0	30.0
TLV1701AIDCKT	SC70	DCK	5	250	190.0	190.0	30.0
TLV1701AIDRLR	SOT-5X3	DRL	5	4000	202.0	201.0	28.0
TLV1701AIDRLT	SOT-5X3	DRL	5	250	202.0	201.0	28.0
TLV1702AIDGKR	VSSOP	DGK	8	2500	364.0	364.0	27.0
TLV1702AIRUGR	X2QFN	RUG	8	3000	202.0	201.0	28.0
TLV1704AIPWR	TSSOP	PW	14	2000	853.0	449.0	35.0

**TUBE**

\*All dimensions are nominal

Device	Package Name	Package Type	Pins	SPQ	L (mm)	W (mm)	T ( $\mu$ m)	B (mm)
TLV1702AIDGK	DGK	VSSOP	8	80	330	6.55	500	2.88
TLV1704AIPW	PW	TSSOP	14	90	530	10.2	3600	3.5



DCK (R-PDSO-G5)

PLASTIC SMALL OUTLINE

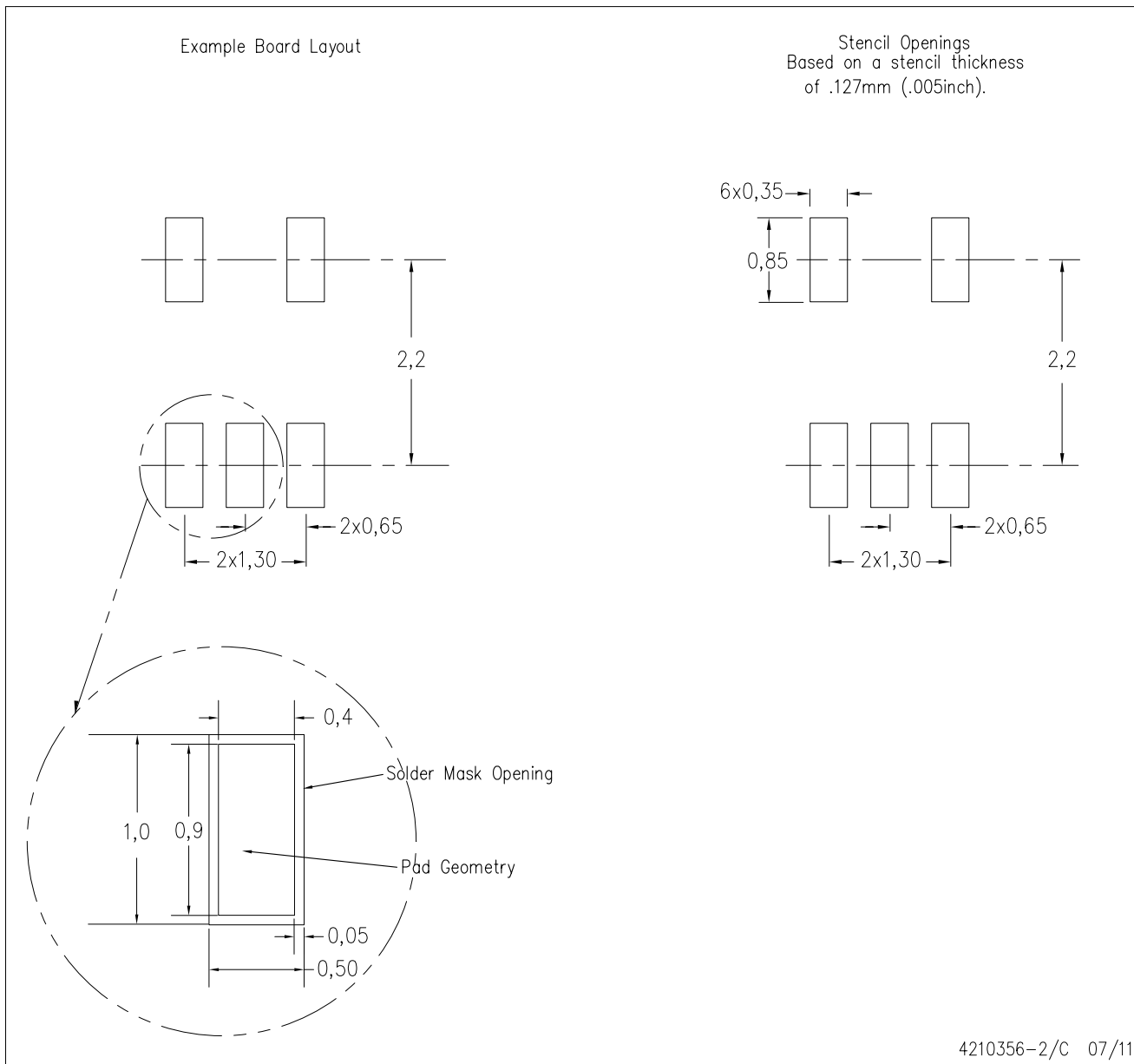

- NOTES:
- All linear dimensions are in millimeters.
  - This drawing is subject to change without notice.
  - Customers should place a note on the circuit board fabrication drawing not to alter the center solder mask defined pad.
  - Publication IPC-7351 is recommended for alternate designs.
  - Laser cutting apertures with trapezoidal walls and also rounding corners will offer better paste release. Customers should contact their board assembly site for stencil design recommendations. Example stencil design based on a 50% volumetric metal load solder paste. Refer to IPC-7525 for other stencil recommendations.



# EXAMPLE BOARD LAYOUT

DBV0005A

SOT-23 - 1.45 mm max height

SMALL OUTLINE TRANSISTOR

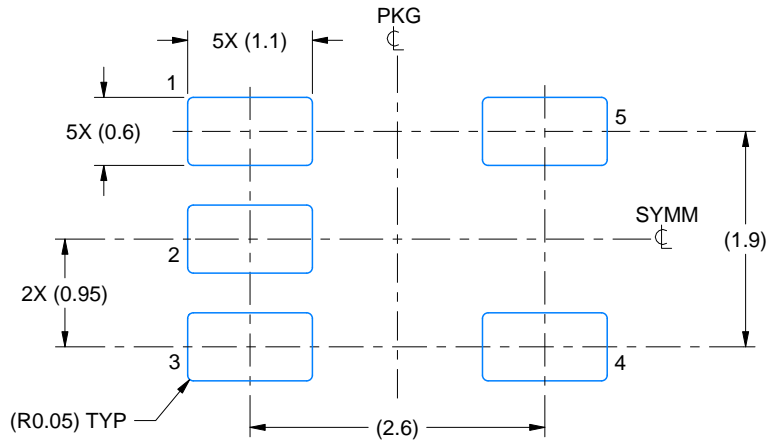

LAND PATTERN EXAMPLE  
EXPOSED METAL SHOWN  
SCALE:15X

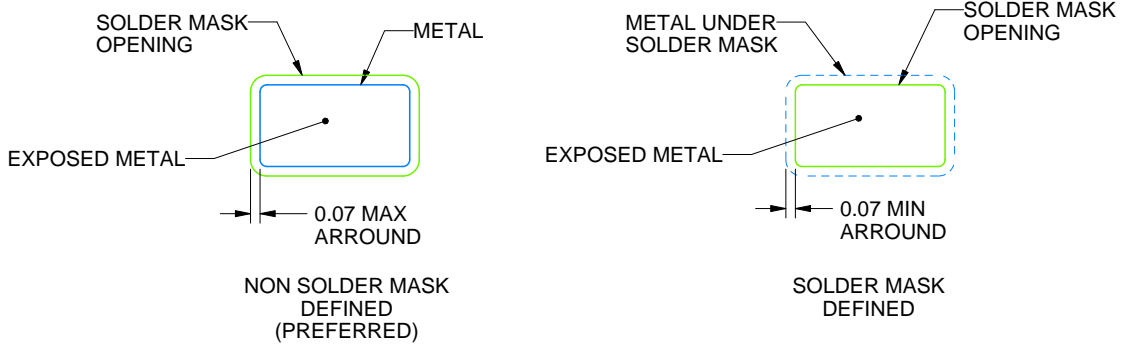

SOLDER MASK DETAILS

4214839/F 06/2021

NOTES: (continued)

- 5. Publication IPC-7351 may have alternate designs.
- 6. Solder mask tolerances between and around signal pads can vary based on board fabrication site.

# EXAMPLE STENCIL DESIGN

DBV0005A

SOT-23 - 1.45 mm max height

SMALL OUTLINE TRANSISTOR

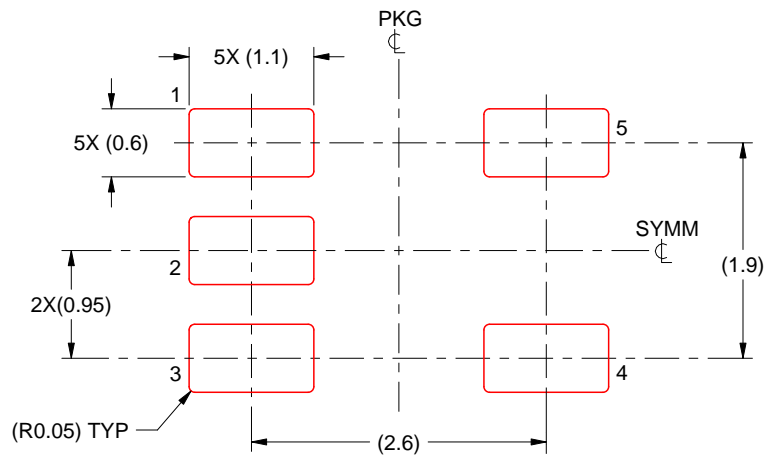

SOLDER PASTE EXAMPLE  
BASED ON 0.125 mm THICK STENCIL  
SCALE:15X

4214839/F 06/2021

NOTES: (continued)

7. Laser cutting apertures with trapezoidal walls and rounded corners may offer better paste release. IPC-7525 may have alternate design recommendations.
8. Board assembly site may have different recommendations for stencil design.

RUG (S-PQFP-N8)

PLASTIC QUAD FLATPACK

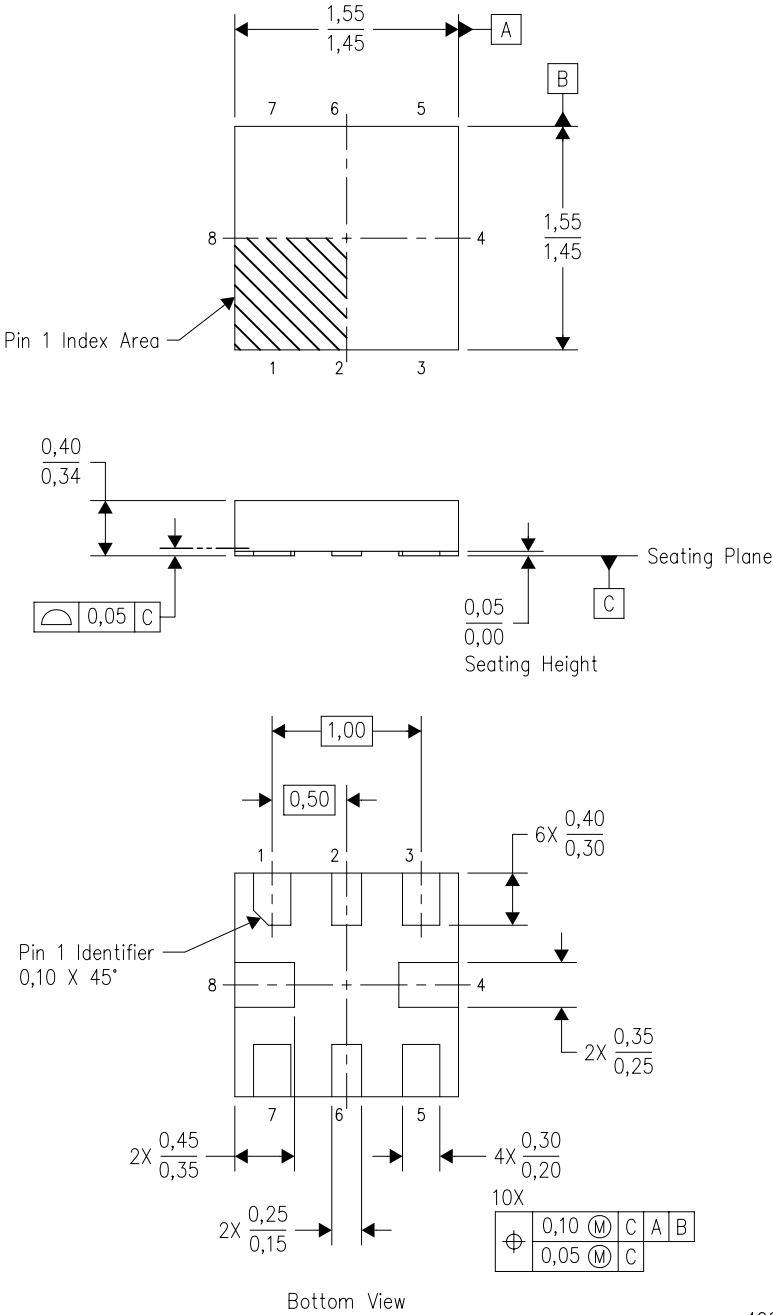

4208528-2/B 04/2008

- NOTES:
- A. All linear dimensions are in millimeters. Dimensioning and tolerancing per ASME Y14.5M-1994.
  - B. This drawing is subject to change without notice.
  - C. QFN (Quad Flatpack No-Lead) package configuration.
  - D. This package complies to JEDEC MO-288 variation X2ECD.

DRL0005A

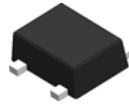

# PACKAGE OUTLINE

SOT - 0.6 mm max height

PLASTIC SMALL OUTLINE

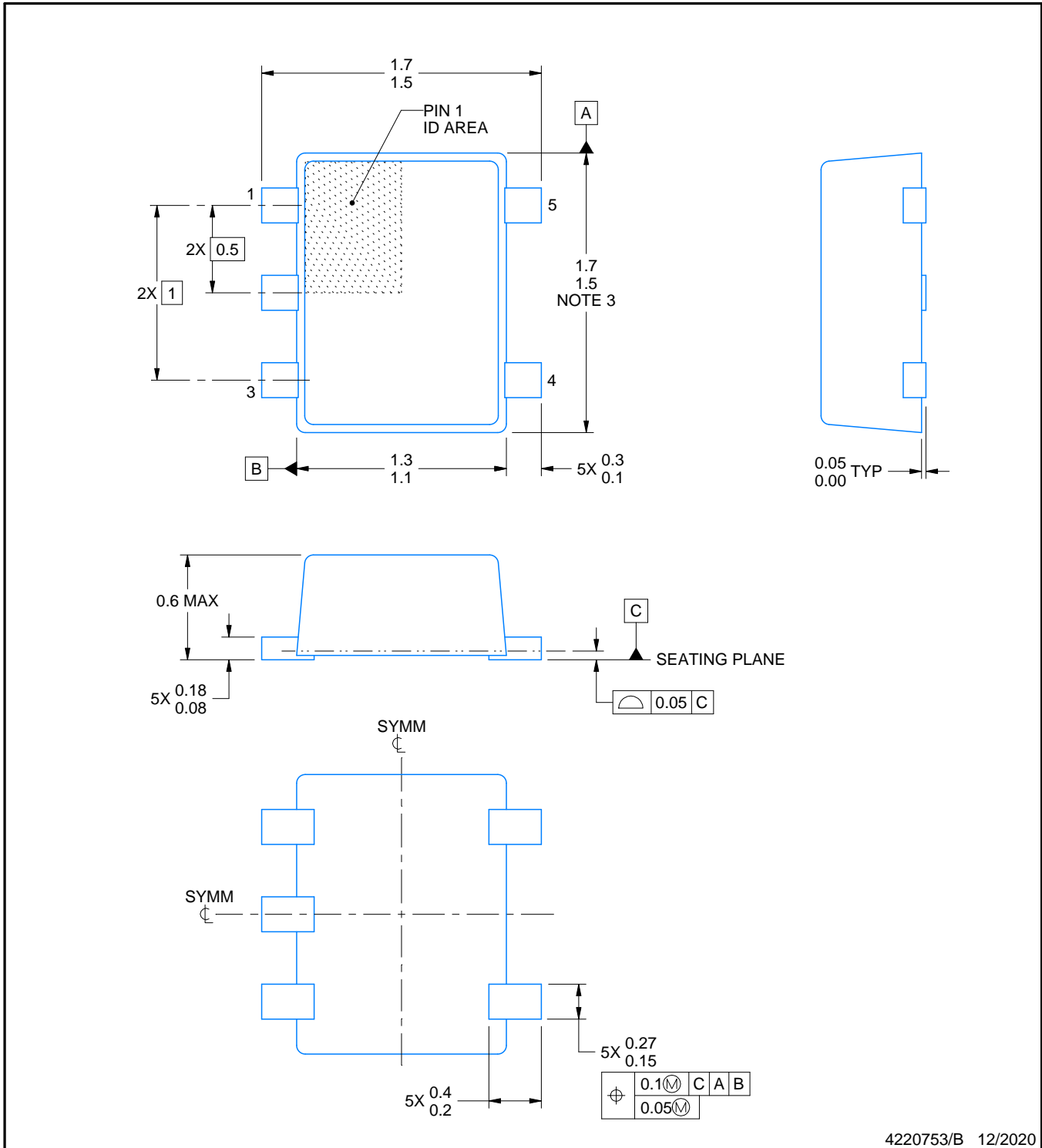

4220753/B 12/2020

NOTES:

1. All linear dimensions are in millimeters. Any dimensions in parenthesis are for reference only. Dimensioning and tolerancing per ASME Y14.5M.
2. This drawing is subject to change without notice.
3. This dimension does not include mold flash, protrusions, or gate burrs. Mold flash, protrusions, or gate burrs shall not exceed 0.15 mm per side.
4. Reference JEDEC registration MO-293 Variation UAAD-1

# EXAMPLE BOARD LAYOUT

DRL0005A

SOT - 0.6 mm max height

PLASTIC SMALL OUTLINE

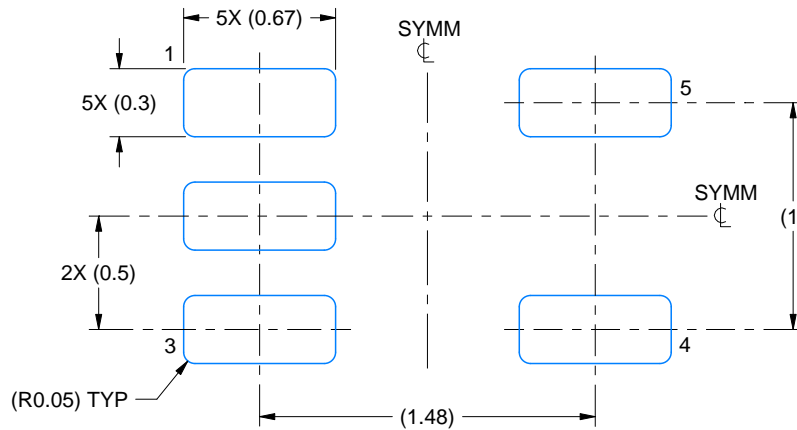

LAND PATTERN EXAMPLE  
SCALE:30X

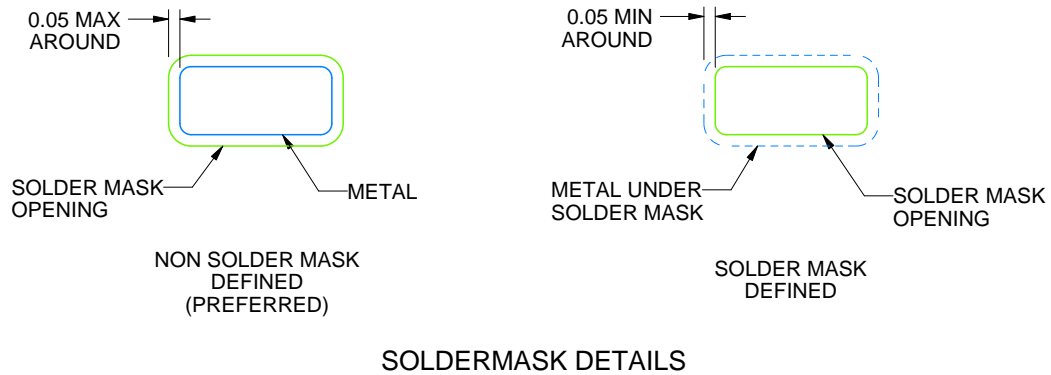

SOLDERMASK DETAILS

4220753/B 12/2020

NOTES: (continued)

- 5. Publication IPC-7351 may have alternate designs.
- 6. Solder mask tolerances between and around signal pads can vary based on board fabrication site.

# EXAMPLE STENCIL DESIGN

DRL0005A

SOT - 0.6 mm max height

PLASTIC SMALL OUTLINE

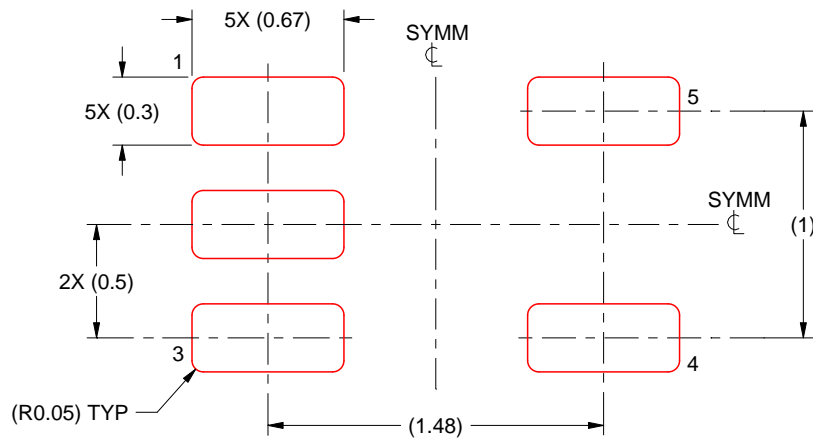

SOLDER PASTE EXAMPLE  
BASED ON 0.1 mm THICK STENCIL  
SCALE:30X

4220753/B 12/2020

NOTES: (continued)

7. Laser cutting apertures with trapezoidal walls and rounded corners may offer better paste release. IPC-7525 may have alternate design recommendations.
8. Board assembly site may have different recommendations for stencil design.

PW (R-PDSO-G14)

PLASTIC SMALL OUTLINE

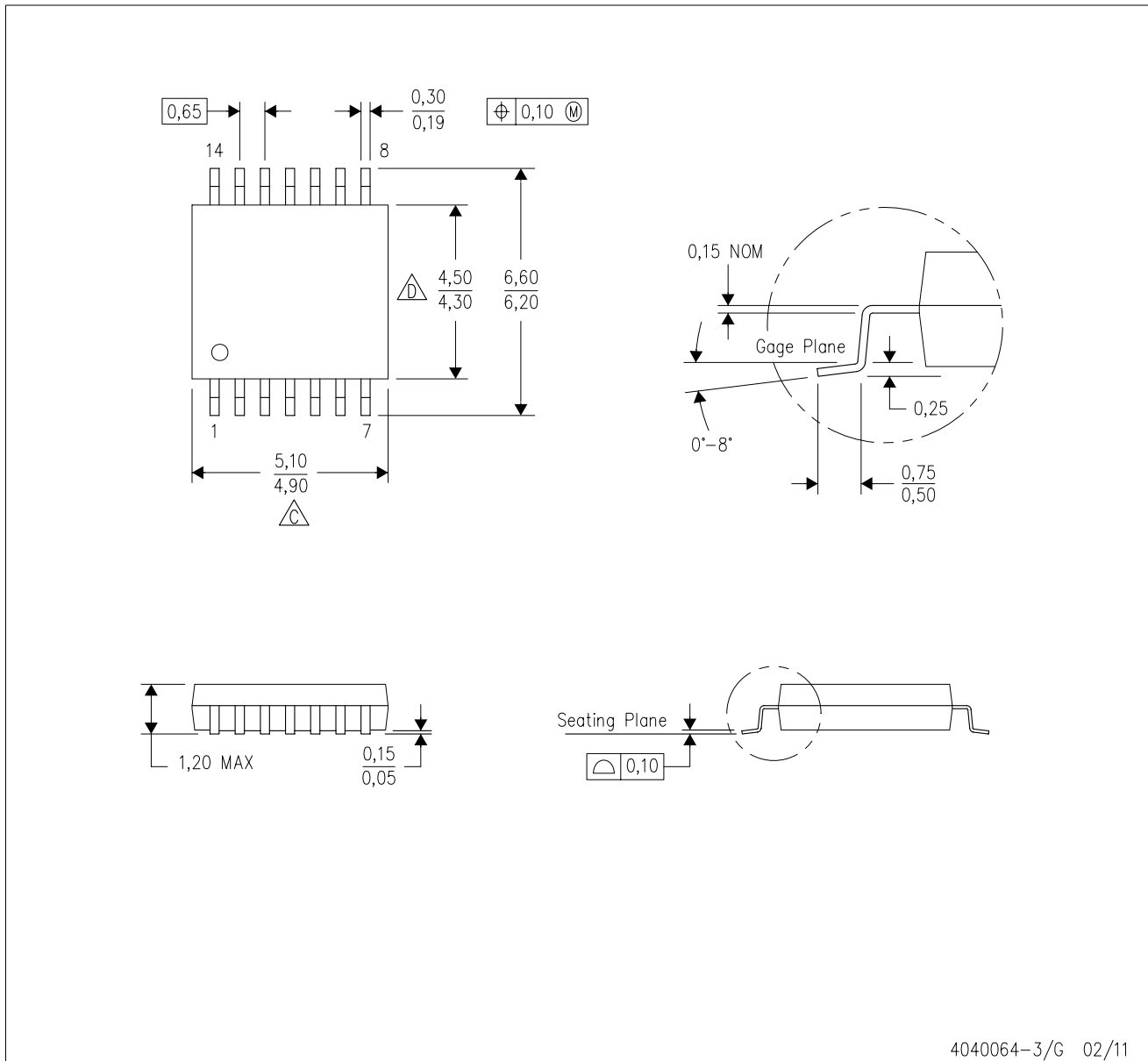

4040064-3/G 02/11

- NOTES:
- A. All linear dimensions are in millimeters. Dimensioning and tolerancing per ASME Y14.5M-1994.
  - B. This drawing is subject to change without notice.
  - C. Body length does not include mold flash, protrusions, or gate burrs. Mold flash, protrusions, or gate burrs shall not exceed 0,15 each side.
  - D. Body width does not include interlead flash. Interlead flash shall not exceed 0,25 each side.
  - E. Falls within JEDEC MO-153

PW (R-PDSO-G14)

PLASTIC SMALL OUTLINE



- NOTES:
- All linear dimensions are in millimeters.
  - This drawing is subject to change without notice.
  - Publication IPC-7351 is recommended for alternate designs.
  - Laser cutting apertures with trapezoidal walls and also rounding corners will offer better paste release. Customers should contact their board assembly site for stencil design recommendations. Refer to IPC-7525 for other stencil recommendations.
  - Customers should contact their board fabrication site for solder mask tolerances between and around signal pads.

DGK (S-PDSO-G8)

PLASTIC SMALL-OUTLINE PACKAGE

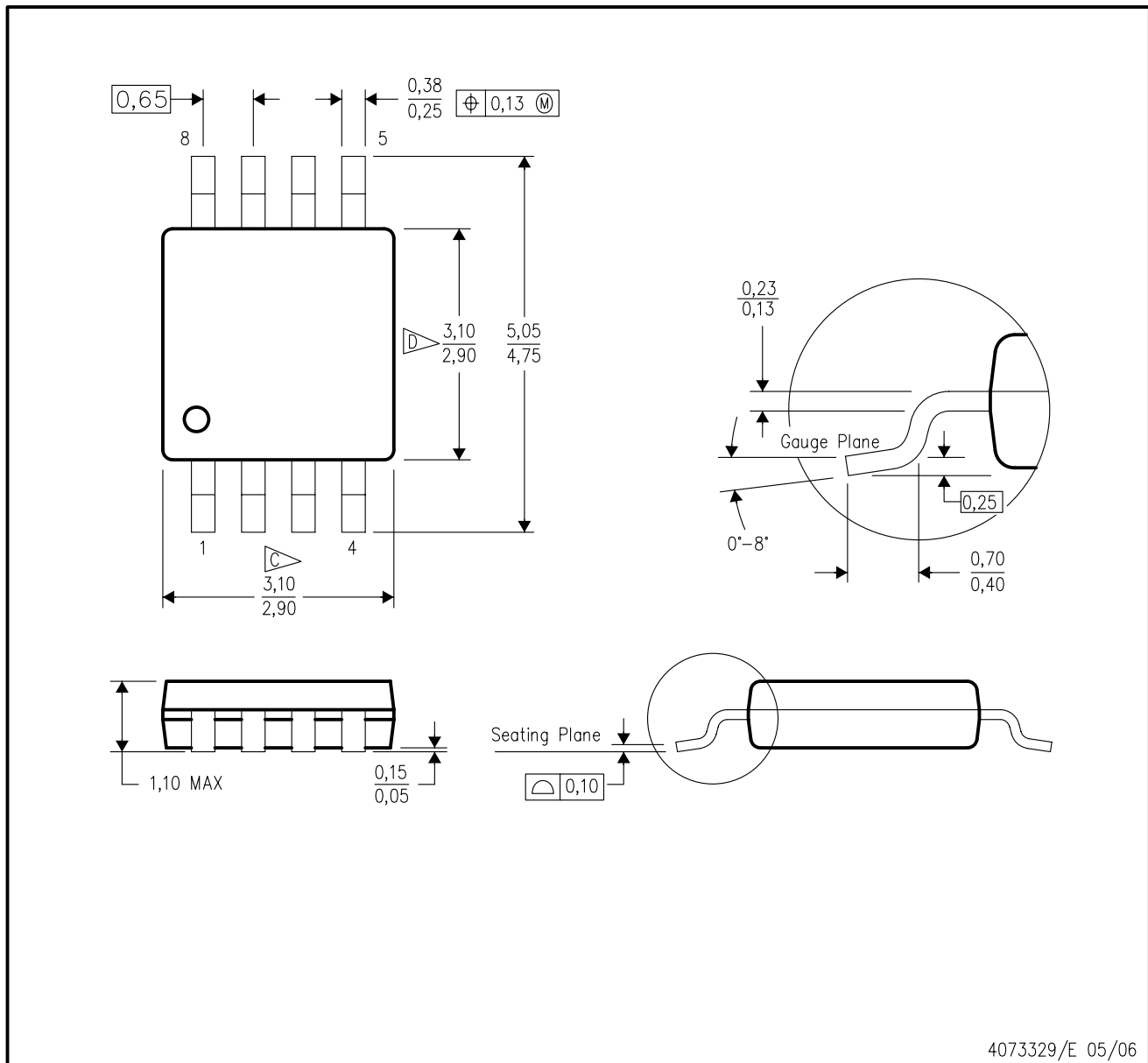

- NOTES:
- All linear dimensions are in millimeters.
  - This drawing is subject to change without notice.
  - Body length does not include mold flash, protrusions, or gate burrs. Mold flash, protrusions, or gate burrs shall not exceed 0.15 per end.
  - Body width does not include interlead flash. Interlead flash shall not exceed 0.50 per side.
  - Falls within JEDEC MO-187 variation AA, except interlead flash.



- NOTES:
- A. All linear dimensions are in millimeters.
  - B. This drawing is subject to change without notice.
  - C. Publication IPC-7351 is recommended for alternate designs.
  - D. Laser cutting apertures with trapezoidal walls and also rounding corners will offer better paste release. Customers should contact their board assembly site for stencil design recommendations. Refer to IPC-7525 for other stencil recommendations.
  - E. Customers should contact their board fabrication site for solder mask tolerances between and around signal pads.

## 重要声明和免责声明

TI“按原样”提供技术和可靠性数据（包括数据表）、设计资源（包括参考设计）、应用或其他设计建议、网络工具、安全信息和其他资源，不保证没有瑕疵且不做任何明示或暗示的担保，包括但不限于对适销性、某特定用途方面的适用性或不侵犯任何第三方知识产权的暗示担保。

这些资源可供使用 TI 产品进行设计的熟练开发人员使用。您将自行承担以下全部责任：(1) 针对您的应用选择合适的 TI 产品，(2) 设计、验证并测试您的应用，(3) 确保您的应用满足相应标准以及任何其他功能安全、信息安全、监管或其他要求。

这些资源如有变更，恕不另行通知。TI 授权您仅可将这些资源用于研发本资源所述的 TI 产品的应用。严禁对这些资源进行其他复制或展示。您无权使用任何其他 TI 知识产权或任何第三方知识产权。您应全额赔偿因在这些资源的使用中对 TI 及其代表造成的任何索赔、损害、成本、损失和债务，TI 对此概不负责。

TI 提供的产品受 [TI 的销售条款](#) 或 [ti.com](#) 上其他适用条款/TI 产品随附的其他适用条款的约束。TI 提供这些资源并不会扩展或以其他方式更改 TI 针对 TI 产品发布的适用的担保或担保免责声明。

TI 反对并拒绝您可能提出的任何其他或不同的条款。

邮寄地址：Texas Instruments, Post Office Box 655303, Dallas, Texas 75265

Copyright © 2022，德州仪器 (TI) 公司