

TPS92612-Q1 汽车单通道 LED 驱动器

1 特性

- 符合面向汽车应用的 AEC-Q100 标准
 - 器件温度等级 1: -40°C 至 125°C , T_A
- 提供功能安全
 - 可帮助创建功能安全系统设计的文档
- 具有 PWM 调光功能的单通道恒定电流 LED 驱动器
- 宽输入电压范围: 4.5V - 40V
- 恒定输出电流, 可通过感应电阻器进行调节
- 高精度电流调节, 容差 $\pm 4.6\%$
- 最大电流: 150mA
- 与外部电阻器实现热共享
- 低压降电压 (包含电流检测压降)
 - 最大压降: 10mA 时为 150mV
 - 最大压降: 70mA 时为 400mV
 - 最大压降: 150mA 时为 700mV
- 低待机电流 (每个器件小于 250 μA)
- 保护:
 - LED 短路保护, 具有自动恢复功能
 - 过热保护
- 工作结温范围: -40°C 至 150°C

2 应用

- 汽车便利照明: 座舱顶灯、车门把手、阅读灯和其他灯具
- 汽车尾灯、中央高位刹车灯、侧面标志灯、盲点监测指示灯、充电口指示灯
- 通用 LED 驱动器 应用

3 说明

随着 LED 在汽车应用中广泛使用, 简单的 LED 驱动器越来越受欢迎。与分立式解决方案相比, 低成本单片解决方案可降低系统级组件数量, 并显著提高电流精度和可靠性。

TPS92612-Q1 器件是一款简单的单通道高侧 LED 驱动器, 由汽车蓄电池供电。这是一种简单而巧妙的解决方案, 能够为单个 LED 灯串提供恒定电流。

器件信息(1)

| 器件型号 | 封装 | 封装尺寸 (标称值) |
|-------------|------------|---------------|
| TPS92612-Q1 | SOT-23 (5) | 2.9mm x 1.6mm |

(1) 如需了解所有可用封装, 请参阅数据表末尾的可订购产品附录。

典型应用图

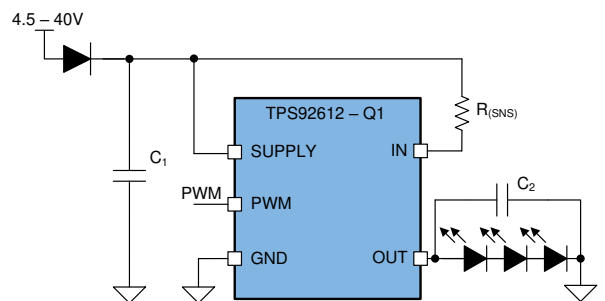

Copyright © 2017, Texas Instruments Incorporated



目录

| | | | | | |
|----------|----------------------------------------------|----------|-----------|---------------------------------------------|-----------|
| 1 | 特性 | 1 | 7.4 | Device Functional Modes | 10 |
| 2 | 应用 | 1 | 8 | Application and Implementation | 11 |
| 3 | 说明 | 1 | 8.1 | Application Information | 11 |
| 4 | 修订历史记录 | 2 | 8.2 | Typical Application | 11 |
| 5 | Pin Configuration and Functions | 3 | 9 | Power Supply Recommendations | 14 |
| 6 | Specifications | 3 | 10 | Layout | 14 |
| 6.1 | Absolute Maximum Ratings | 3 | 10.1 | Layout Guidelines | 14 |
| 6.2 | ESD Ratings | 3 | 10.2 | Layout Example | 15 |
| 6.3 | Recommended Operating Conditions | 4 | 11 | 器件和文档支持 | 16 |
| 6.4 | Thermal Information | 4 | 11.1 | 文档支持 | 16 |
| 6.5 | Electrical Characteristics | 4 | 11.2 | 接收文档更新通知 | 16 |
| 6.6 | Timing Requirements | 5 | 11.3 | 社区资源 | 16 |
| 6.7 | Typical Characteristics | 6 | 11.4 | 商标 | 16 |
| 7 | Detailed Description | 9 | 11.5 | 静电放电警告 | 16 |
| 7.1 | Overview | 9 | 11.6 | Glossary | 16 |
| 7.2 | Functional Block Diagram | 9 | 12 | 机械、封装和可订购信息 | 16 |
| 7.3 | Feature Description | 9 | | | |

4 修订历史记录

Changes from Revision A (July 2018) to Revision B Page

- 向 [特性](#) 部分添加了提供功能安全的链接

1

Changes from Original (January 2018) to Revision A Page

- Changed "ambient temperature" to "junction temperature" in the condition statements of the *Absolute Maximum Ratings* and *Recommended Operating Conditions* tables
- Added ESD classification levels for HBM and CDM to the *ESD Ratings* table
- Changed rising and falling thresholds
- Added capacitors C_1 and C_2
- Added capacitors C_1 and C_2
- Added capacitors C_1 and C_2

3

3

4

11

12

15

5 Pin Configuration and Functions

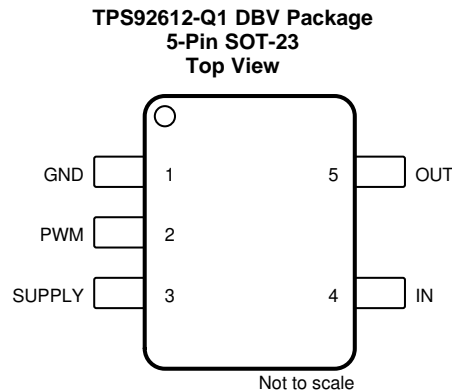

Pin Functions

| PIN | | I/O | DESCRIPTION |
|--------|--------------------|-----|-------------------------|
| NAME | NO. TPS92612-Q1 | | |
| GND | 1 | — | Ground |
| IN | 4 | I | Current input |
| OUT | 5 | O | Constant-current output |
| PWM | 2 | I | PWM input |
| SUPPLY | 3 | I | Device supply voltage |

6 Specifications

6.1 Absolute Maximum Ratings

over operating junction temperature range (unless otherwise noted)⁽¹⁾

| | | MIN | MAX | UNIT |
|---------------------------------------|---------------------------|------|-----|------|
| High-voltage input | IN, PWM, SUPPLY | −0.3 | 45 | V |
| High-voltage output | OUT | −0.3 | 45 | V |
| IN to OUT | $V_{(IN)} - V_{(OUT)}$ | −0.3 | 45 | V |
| SUPPLY to IN | $V_{(SUPPLY)} - V_{(IN)}$ | −0.3 | 1 | V |
| Operating junction temperature, T_J | | −40 | 150 | °C |
| Storage temperature, T_{stg} | | −40 | 150 | °C |

(1) Stresses beyond those listed under *Absolute Maximum Ratings* may cause permanent damage to the device. These are stress ratings only, which do not imply functional operation of the device at these or any other conditions beyond those indicated under *Recommended Operating Conditions*. Exposure to absolute-maximum-rated conditions for extended periods may affect device reliability.

6.2 ESD Ratings

| | | | VALUE | UNIT |
|-------------|-------------------------|------------------------------------------------------------------------------------------------------------------------------------------------------------------------|-------|------|
| $V_{(ESD)}$ | Electrostatic discharge | Human-body model (HBM), per AEC Q100-002 ⁽¹⁾ HBM ESD Classification Level 2 | ±2000 | V |
| | | Charged-device model (CDM), per AEC Q100-011 CDM ESD Classification Level C3B [There isn't a C3B classification, unless there is a mistake in STDZ0171 on page 84.] | ±500 | |
| | | Corner pins (3, 4, and 5) | ±750 | |

(1) AEC Q100-002 indicates that HBM stressing shall be in accordance with the ANSI/ESDA/JEDEC JS-001 specification.

6.3 Recommended Operating Conditions

over operating junction temperature range (unless otherwise noted)

| | | MIN | NOM | MAX | UNIT |
|----------------|-------------------------------|-----|-----|-----|------|
| SUPPLY | Device supply voltage | 4.5 | | 40 | V |
| IN | Sense voltage | 4.4 | | 40 | V |
| PWM | PWM inputs | 0 | | 40 | V |
| OUT | Driver output | 0 | | 40 | V |
| T _A | Operating ambient temperature | –40 | | 125 | °C |

6.4 Thermal Information

| THERMAL METRIC ⁽¹⁾ | | TPS92612-Q1 | UNIT |
|-------------------------------|----------------------------------------------|-------------|------|
| | | DBV (SOT23) | |
| | | 5 PINS | |
| R _{θJA} | Junction-to-ambient thermal resistance | 200.7 | °C/W |
| R _{θJC(top)} | Junction-to-case (top) thermal resistance | 104.4 | °C/W |
| R _{θJB} | Junction-to-board thermal resistance | 45.6 | °C/W |
| ψ _{JT} | Junction-to-top characterization parameter | 17.5 | °C/W |
| ψ _{JB} | Junction-to-board characterization parameter | 45.2 | °C/W |

 (1) For more information about traditional and new thermal metrics, see [Semiconductor and IC Package Thermal Metrics](#).

6.5 Electrical Characteristics

 V_(SUPPLY) = 5 V to 40 V, T_J = –40°C to 150°C unless otherwise noted

| PARAMETER | | TEST CONDITIONS | MIN | TYP | MAX | UNIT |
|--------------------------------|---------------------------------------------------------------------|------------------------------------------------------------------------|-------|-------|-------|------|
| BIAS | | | | | | |
| V _(POR_rising) | Supply voltage POR rising threshold | | | 3.2 | 4 | V |
| V _(POR_falling) | Supply voltage POR falling threshold | | 2.2 | 3 | | V |
| I _(Quiescent) | Device standby current | PWM = LOW | 0.1 | 0.2 | 0.25 | mA |
| LOGIC INPUTS (PWM) | | | | | | |
| V _{IL(PWM)} | Input logic-low voltage, PWM | | 1.045 | 1.1 | 1.155 | V |
| V _{IH(PWM)} | Input logic-high voltage, PWM | | 1.14 | 1.2 | 1.26 | V |
| CONSTANT-CURRENT DRIVER | | | | | | |
| I _(OUT) | Device output-current range | 100% duty cycle | 4 | | 150 | mA |
| V _(CS_REG) | Sense-resistor regulation voltage | T _A = 25°C, V _(SUPPLY) = 4.5 V to 18 V | 94 | 98 | 102 | mV |
| | | T _A = –40°C to 125°C, V _(SUPPLY) = 4.5 V to 18 V | 93.5 | 98 | 102.5 | |
| R _(CS_REG) | Sense-resistor value | | | | 24.5 | Ω |
| V _(DROPOUT) | Voltage dropout from SUPPLY to OUT | V _(CS_REG) voltage included, current setting = 10 mA | | 120 | 150 | mV |
| | | V _(CS_REG) voltage included, current setting = 70 mA | | 250 | 400 | |
| | | V _(CS_REG) voltage included, current setting = 150 mA | | 430 | 700 | |
| DIAGNOSTICS | | | | | | |
| V _(SG_th_falling) | Channel output V _(OUT) short-to-ground falling threshold | | 1.14 | 1.2 | 1.26 | V |
| V _(SG_th_rising) | Channel output V _(OUT) short-to-ground rising threshold | | 0.82 | 0.865 | 0.91 | V |
| I _(Retry) | Channel output V _(OUT) short-to-ground retry current | V _(OUT) = 0 V | 0.64 | 1.08 | 1.528 | mA |

Electrical Characteristics (continued)

$V_{(SUPPLY)} = 5\text{ V to }40\text{ V}$, $T_J = -40^\circ\text{C to }150^\circ\text{C}$ unless otherwise noted

| PARAMETER | | TEST CONDITIONS | MIN | TYP | MAX | UNIT |
|---------------------------|--------------------------------------------------|-----------------|-----|-----|-----|------------------|
| THERMAL PROTECTION | | | | | | |
| $T_{(TSD)}$ | Thermal shutdown junction temperature threshold | | | 172 | | $^\circ\text{C}$ |
| $T_{(TSD_HYS)}$ | Thermal shutdown junction temperature hysteresis | | | 15 | | $^\circ\text{C}$ |

6.6 Timing Requirements

| | | MIN | NOM | MAX | UNIT |
|-----------------------------|-----------------------------------------------------------------------------------------------|-----|-----|-----|---------------|
| $t_{(PWM_delay_rising)}$ | PWM rising edge delay, 50% PWM voltage to 10% of output current, $t_2 - t_1$ as shown in 图 1 | | 17 | | μs |
| $t_{(PWM_delay_falling)}$ | PWM falling edge delay, 50% PWM voltage to 90% of output current, $t_5 - t_4$ as shown in 图 1 | | 21 | | μs |
| $t_{(TSD_deg)}$ | Thermal overtemperature deglitch time | | 60 | | μs |
| $t_{(SG_deg)}$ | Channel-output short-to-ground detection deglitch time | 80 | 125 | 175 | μs |
| $t_{(Recover_deg)}$ | Recovery deglitch time | | 16 | | μs |

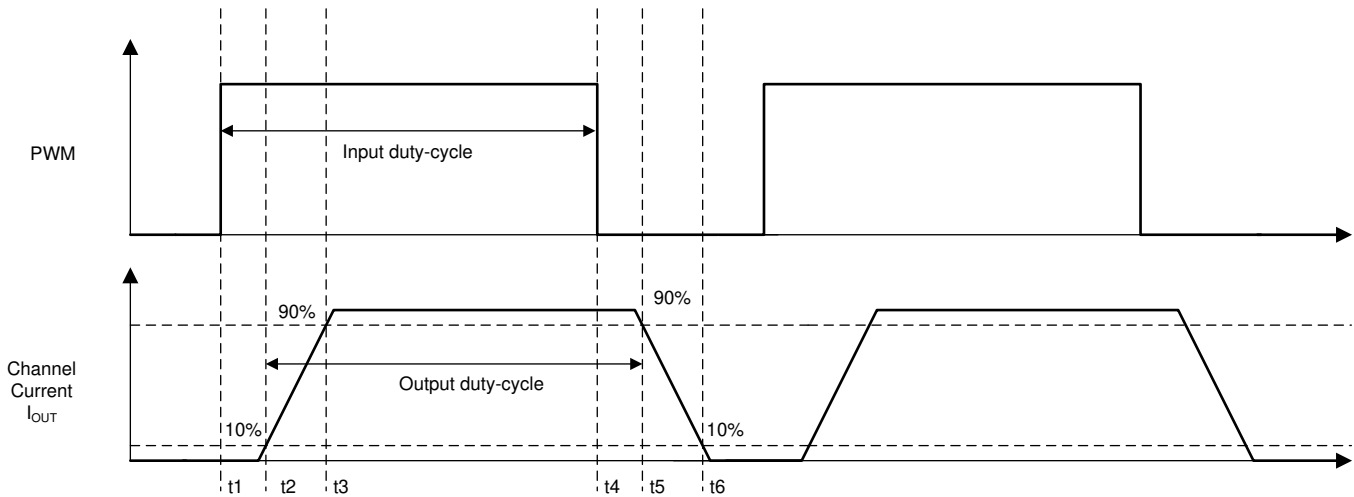

Copyright © 2017, Texas Instruments Incorporated

图 1. Output Timing Diagram

6.7 Typical Characteristics

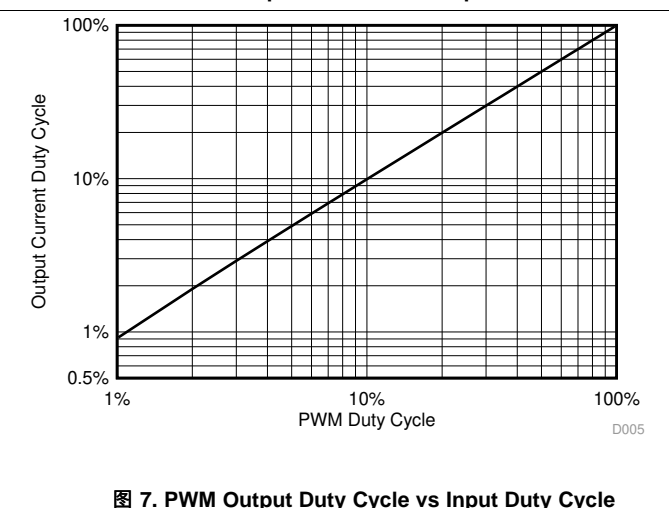
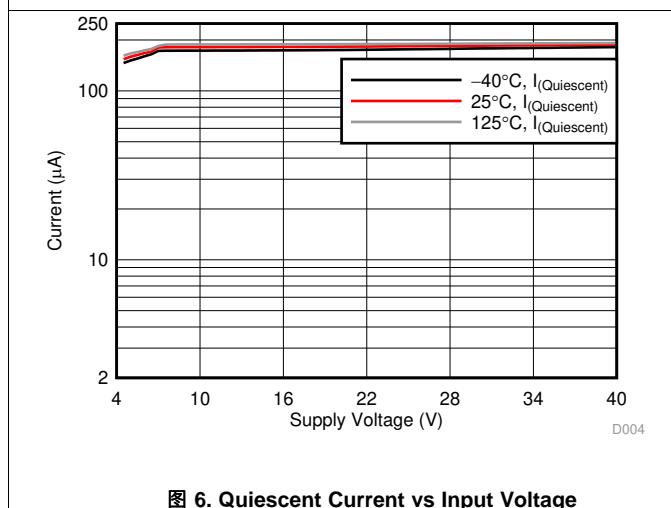
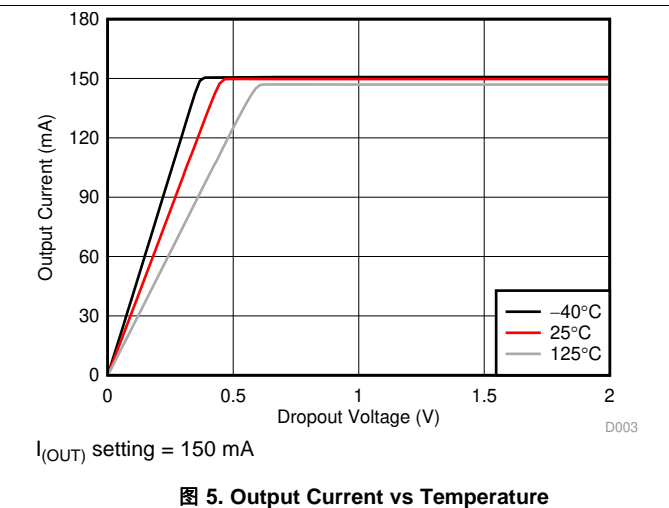
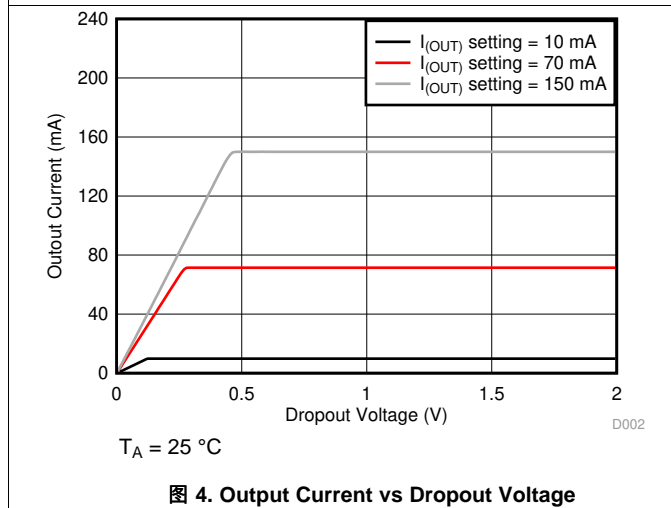
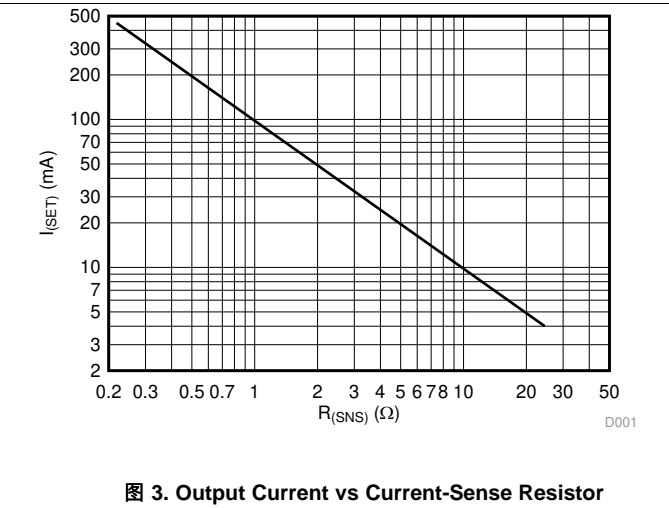
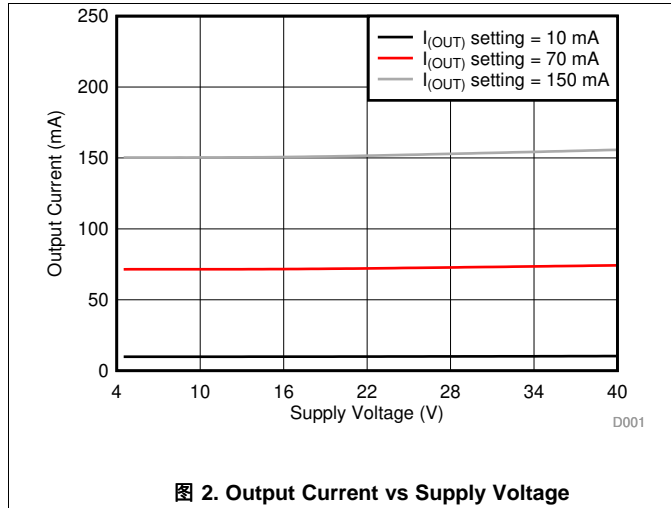

Typical Characteristics (接下页)

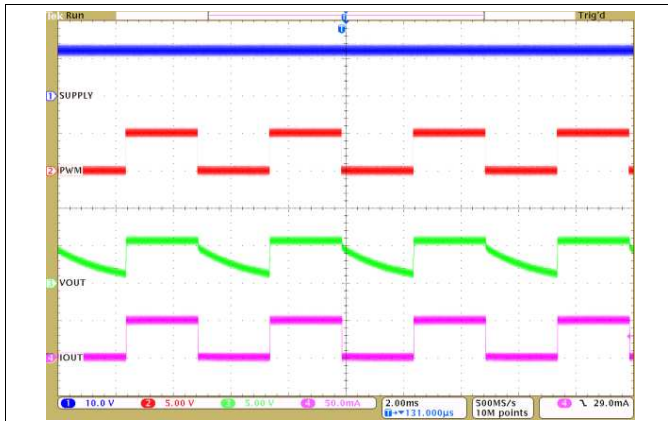

Ch. 1 = $V_{(SUPPLY)}$ Ch. 2 = $V_{(PWM)}$ Ch. 3 = $I_{(OUT)}$
 Ch. 4 = $V_{(OUT)}$ $f_{(PWM)} = 200 \text{ Hz}$ Duty-cycle = 50%

图 8. PWM Dimming via External Input

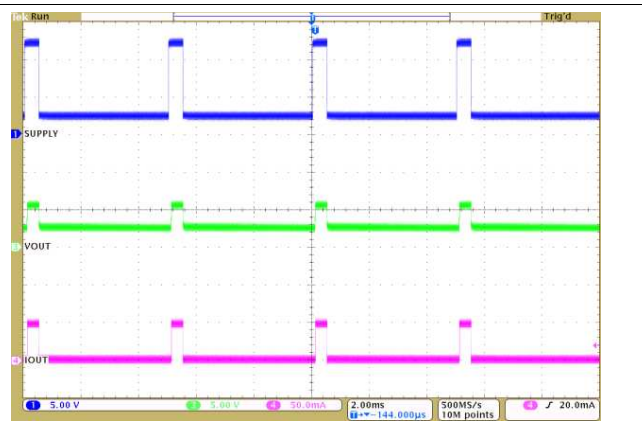

Ch. 1 = $V_{(SUPPLY)}$ Ch. 3 = $V_{(OUT)}$ Ch. 4 = $I_{(OUT)}$
 $f_{(PWM)} = 200 \text{ Hz}$ Duty-cycle = 10%
 SUPPLY dimming between 2.5 V and 12 V

图 9. PWM Dimming via Power Supply

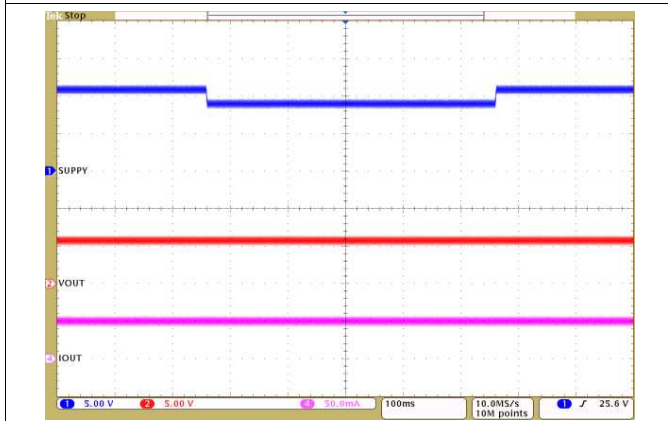

Ch. 1 = SUPPLY Ch. 2 = $V_{(OUT)}$ Ch. 4 = $I_{(OUT)}$

图 10. Transient Undervoltage

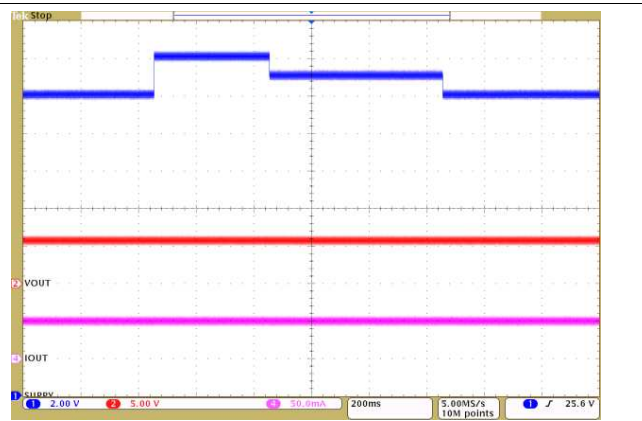

Ch. 1 = SUPPLY Ch. 2 = $V_{(OUT)}$ Ch. 4 = $I_{(OUT)}$

图 11. Transient Overvoltage

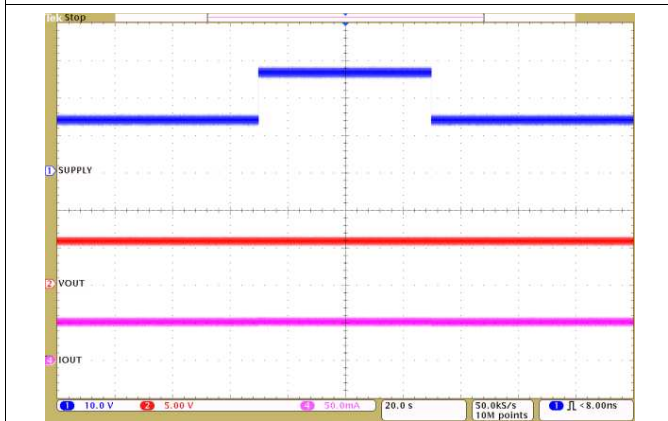

Ch. 1 = SUPPLY Ch. 2 = $V_{(OUT)}$ Ch. 4 = $I_{(OUT)}$

图 12. Jump Start

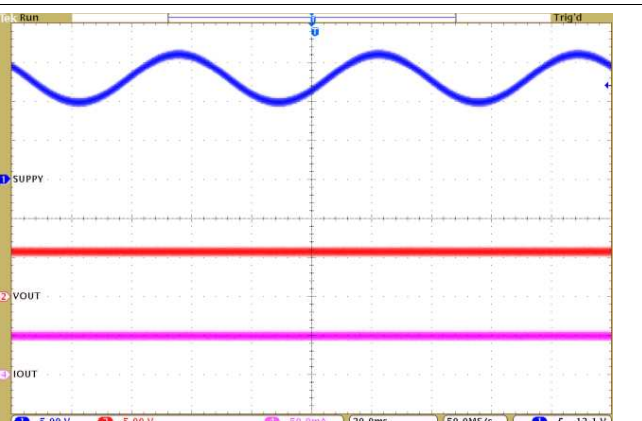

Ch. 1 = SUPPLY Ch. 2 = $V_{(OUT)}$ Ch. 4 = $I_{(OUT)}$

图 13. Superimposed Alternating Voltage, 15 Hz

Typical Characteristics (接下页)



图 14. Superimposed Alternating Voltage, 1kHz



图 15. Slow Decrease, Quick Increase of Supply Voltage

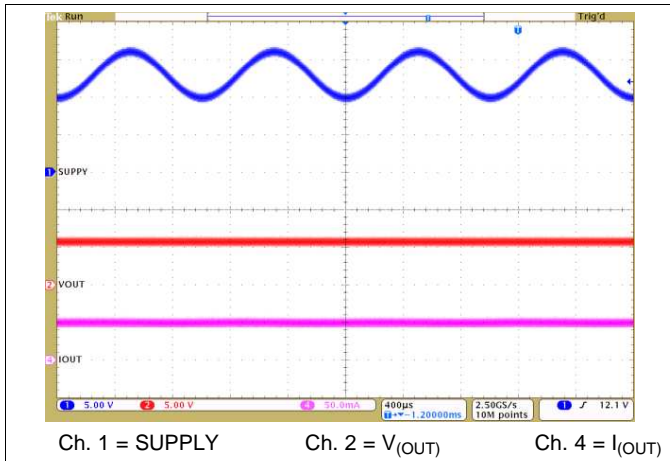

图 16. Slow Decrease and Slow Increase of Supply Voltage

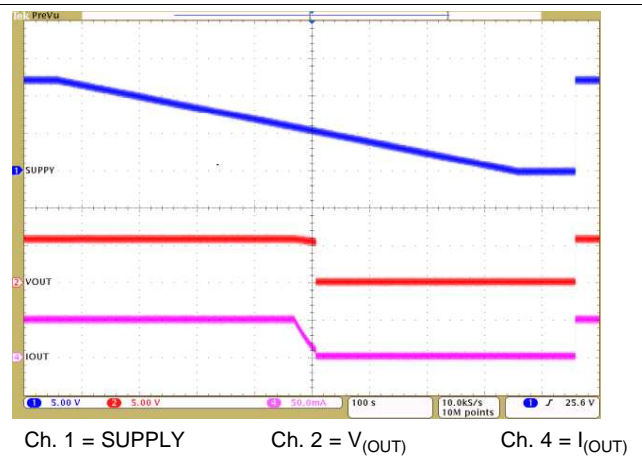

图 17. LED Open-Circuit and Recovery

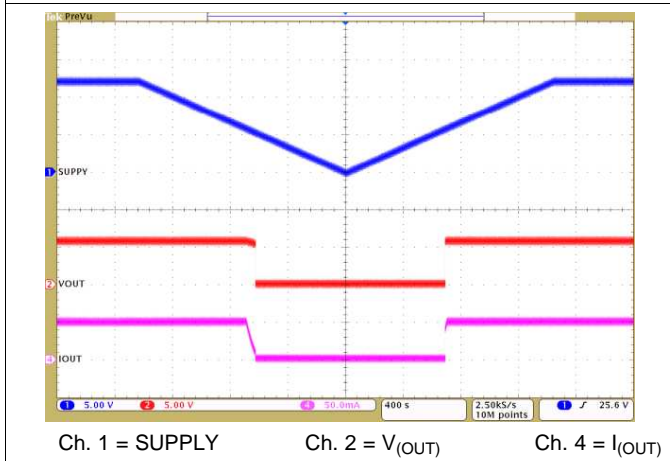

图 18. LED Short-Circuit Protection and Recovery

7 Detailed Description

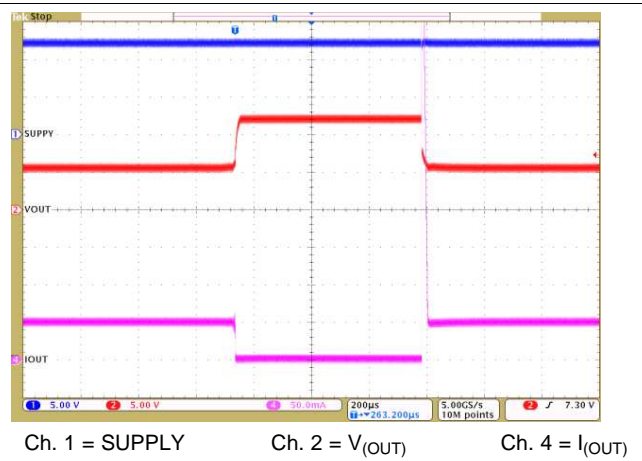
7.1 Overview

The TPS92612-Q1 device is the one of a family of single-channel linear LED drivers. The device provides a simple current source with protection for automotive LED applications.

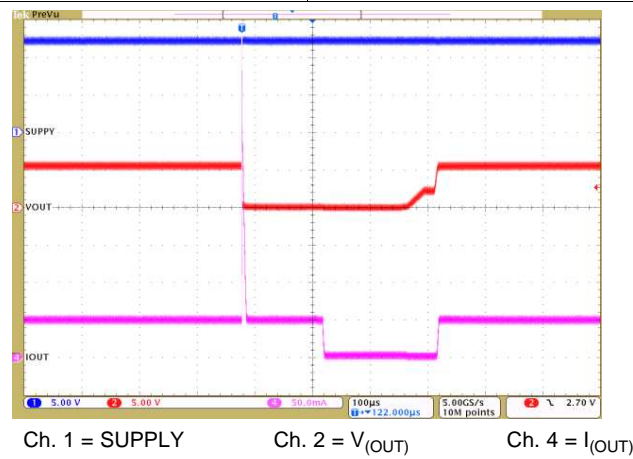
The output current can be set by an external $R_{(SNS)}$ resistor. Current flows from the supply through the $R_{(SNS)}$ resistor into the internal current source and to the LEDs.

7.2 Functional Block Diagram

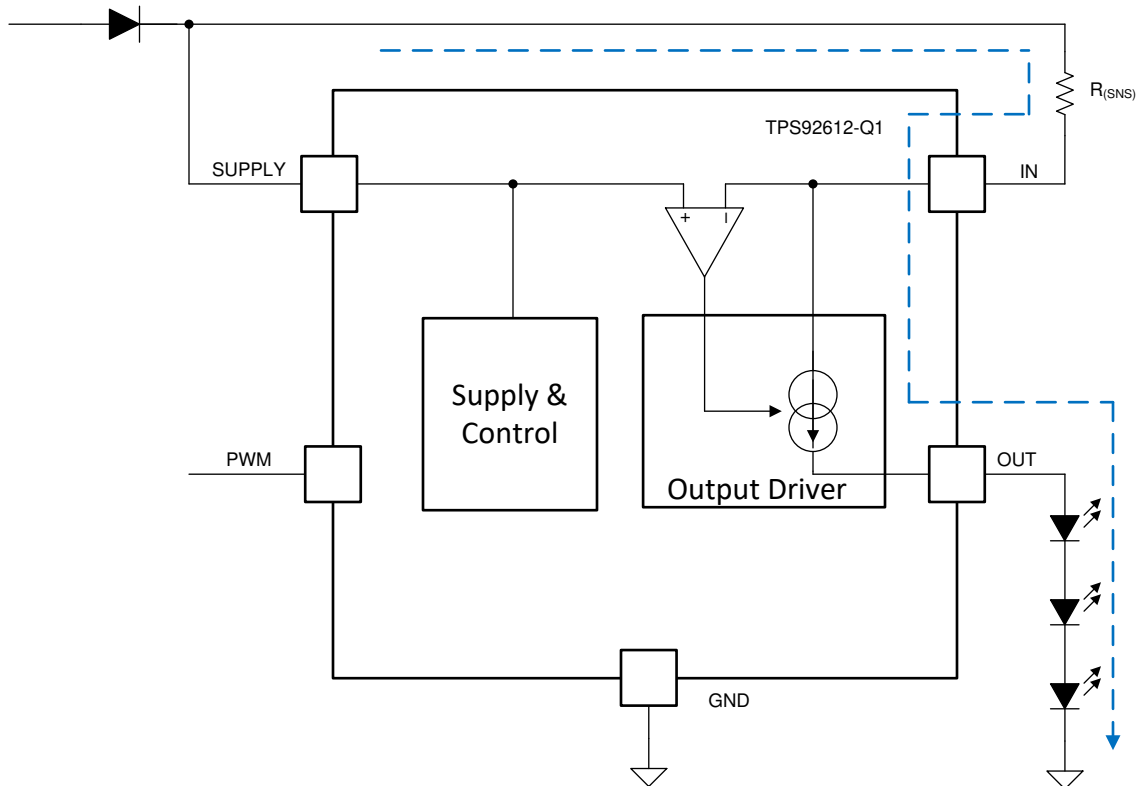

Copyright ©2017, Texas Instruments Incorporated

7.3 Feature Description

7.3.1 Device Bias

7.3.1.1 Power-On Reset (POR)

The TPS92612-Q1 device has an internal power-on-reset (POR) function. When power is applied to SUPPLY, the internal POR holds the device in the reset condition until $V_{(SUPPLY)}$ reaches $V_{(POR_rising)}$.

7.3.2 Constant-Current Driver

The TPS92612-Q1 device has a high-side constant-current integrated driver. The device senses channel current with an external high-side current-sense resistor, $R_{(SNS)}$. A current regulation loop drives an internal transistor and regulates the current-sense voltage at the current-sense resistor to $V_{(CS_REG)}$. When the output driver is in regulation, the output current can be set by the current-sense resistor using the following equation.

$$I_{(OUT)} = \frac{V_{(CS_REG)}}{R_{(SNS)}} \quad (1)$$

Feature Description (接下页)

7.3.3 PWM Dimming

The TPS92612-Q1 device supports PWM dimming via PWM input dimming and supply dimming.

The PWM input functions as an enable for the output current.

Supply dimming applies PWM dimming on the power input. For an accurate PWM threshold, TI recommends using a resistor divider on the PWM input stage to set the PWM threshold higher than $V_{(POR_rising)}$.

7.3.4 Protection

7.3.4.1 Short-to-GND Protection

The TPS92612-Q1 device has LED short-to-GND protection. Short-to-GND detection monitors the output voltage when the channel is in the ON state. Once a short-to-GND LED failure is detected, the device turns off the output channel and retries automatically, ignoring the PWM input. If the retry mechanism detects removal of the LED short-to-GND fault, the device resumes normal operation.

The device monitors the $V_{(OUT)}$ voltage and compares it with the internal reference voltage to detect a short-to-GND failure. If $V_{(OUT)}$ falls below $V_{(SG_th_rising)}$ longer than the deglitch time of $t_{(SG_deg)}$, the device asserts the short-to-GND fault. During the deglitching time period, if $V_{(OUT)}$ rises above $V_{(SG_th_falling)}$, the timer is reset.

Once the device has detected a short-to-GND fault, the device turns off the output channel and retries automatically with a small current. When retrying, the device sources a small current $I_{(retry)}$ from IN to OUT to pull up the LED loads continuously. Once auto retry detects output voltage rising above $V_{(SG_th_falling)}$, the device clears the short-to-GND fault and resumes normal operation.

7.3.4.2 Overtemperature Protection

The TPS92612-Q1 device monitors device junction temperature. When the junction temperature reaches thermal shutdown threshold $T_{(TSD)}$, the output shuts down. Once the junction temperature falls below $T_{(TSD)} - T_{(TSD_HYS)}$, the device resumes normal operation.

7.4 Device Functional Modes

7.4.1 Undervoltage Lockout, $V_{(SUPPLY)} < V_{(POR_rising)}$

When the device is in undervoltage lockout mode, the TPS92612-Q1 device disables all functions until the supply rises above the POR-rising threshold.

7.4.2 Normal Operation, $V_{(SUPPLY)} \geq 4.5\text{ V}$

The device drives an LED string in normal operation. With enough voltage drop across SUPPLY and OUT, the device is able to drive the output in constant-current mode.

8 Application and Implementation

注

Information in the following applications sections is not part of the TI component specification, and TI does not warrant its accuracy or completeness. TI's customers are responsible for determining suitability of components for their purposes. Customers should validate and test their design implementation to confirm system functionality.

8.1 Application Information

In automotive lighting applications, thermal performance is always a design challenge for linear LED drivers.

To increase current-driving capability, the TPS92612-Q1 device supports heat sharing using an external parallel resistor as shown in 图 21. This technique provides the low-cost solution of using external resistors to dissipate heat due to high input voltage, and still keeps high accuracy of the total current output.

8.2 Typical Application

8.2.1 Single-Channel LED Driver

The TPS92612-Q1 device can be a good fit for many automotive lighting applications.



图 19. Typical Application Diagram

8.2.1.1 Design Requirements

Input voltage range is 9 V to 16 V, LED maximum forward voltage $V_{fmax} = 2.5$ V, minimum forward voltage $V_{fmin} = 1.9$ V, current $I_{(LED)} = 50$ mA.

8.2.1.2 Detailed Design Procedure

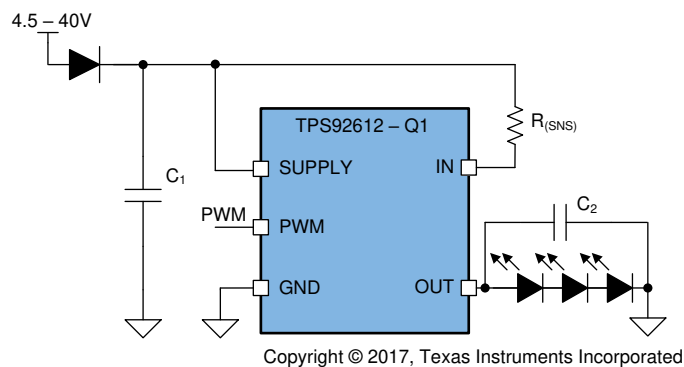
Current setting by the sense resistor is as described in 公式 1.

$$R_{(SNS)} = \frac{V_{(CS_REG)}}{I_{(LED)}} = 1.96\Omega \quad (2)$$

LED-string maximum forward voltage = 3×2.5 V = 7.5 V.

Total device power consumption at worst case is with 16-V input and LEDs at minimal forward voltage.

$$\begin{aligned} P_{(Max)} &= (V_{(SUPPLY)} - V_{(CS_REG)} - V_{(OUT)}) \times I_{(LED)} + V_{(SUPPLY)} \times I_{(Quiescent)} \\ &= (16 - 3 \times 1.9 - 0.098) \times 0.05 + 16 \times 0.00025 = 0.5141 \text{ W} \end{aligned} \quad (3)$$

TI recommends to add capacitors C_1 and C_2 at SUPPLY and OUT. TI recommends C_1 of 1 μ F and 100 nF close to the SUPPLY pin, and C_2 of 10 nF close to the OUT pin. A larger capacitor for C_1 or C_2 is helpful for EMC and ESD; however, it takes a longer time to charge up the capacitor and could affect PWM dimming performance.

Typical Application (接下页)

8.2.1.3 Application Curve

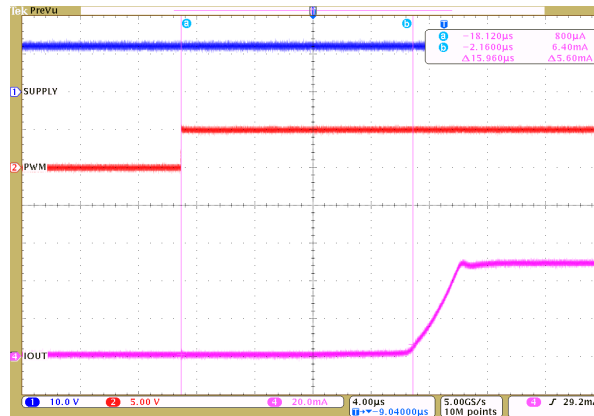

Ch. 1 = $V_{(OUT)}$ Ch. 2 = $V_{(PWM)}$ Ch. 4 = $I_{(OUT)}$

图 20. Output Current With PWM Input

8.2.2 Single-Channel LED Driver With Heat Sharing

Using parallel resistors, thermal performance can be improved by balancing current between the TPS92612-Q1 device and the external resistors as follows. As the current-sense resistor controls the total LED string current, the LED string current $I_{(LED)}$ is set by $V_{(CS_REG)} / R_{(SNS)}$, while the TPS92612-Q1 current $I_{(DRIVE)}$ and parallel resistor current $I_{(P)}$ combine to the total current.



图 21. Heat Sharing With a Parallel Resistor

8.2.2.1 Design Requirements

The input voltage range is 9 V to 16 V, LED maximum forward voltage $V_{fmax} = 2.5$ V, minimum forward voltage $V_{fmin} = 1.9$ V, current $I_{(LED)} = 100$ mA.

8.2.2.2 Detailed Design Procedure

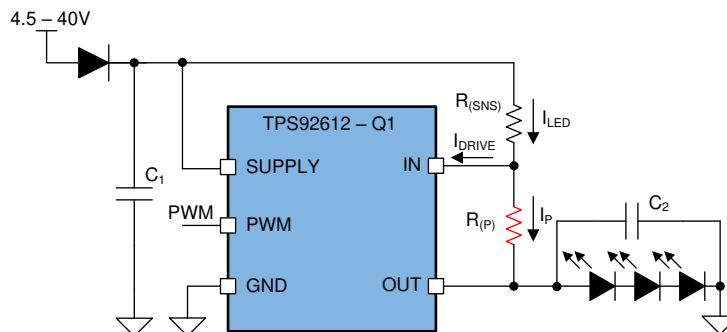
In linear LED driver applications, the input voltage variation contributes to most of the thermal concerns. The resistor current, as indicated by Ohm's law, depends on the voltage across the external resistors. The TPS92612-Q1 device controls the driver current $I_{(DRIVE)}$ to attain the desired total current. If $I_{(P)}$ increases, the TPS92612-Q1 device decreases $I_{(DRIVE)}$ to compensate, and vice versa.

While in low-dropout mode, the voltage across the $R_{(P)}$ resistor may be close to zero, so that almost no current can flow through the external resistor $R_{(P)}$.

Typical Application (接下页)

When the input voltage is high, parallel-resistor current $I_{(P)}$ is proportional to the voltage across the parallel resistor, $R_{(P)}$. The parallel resistor, $R_{(P)}$, takes the majority of the total string current, generating maximum heat. The device must prevent current from draining out to ensure current regulation capability.

In this case, the parallel resistor value must be carefully calculated to ensure that 1) enough output current is achieved in low-dropout mode, 2) thermal dissipation for both the TPS92612-Q1 device and the resistor is within their thermal dissipation limits, and 3) device current in the high-voltage mode is above the minimal output-current requirement.

TI recommends to add capacitors C_1 and C_2 at SUPPLY and OUT. TI recommends C_1 of 1 μ F and 100 nF close to the SUPPLY pin, and C_2 of 10 nF close to the OUT pin. A larger capacitor for C_1 or C_2 is helpful for EMC and ESD; however, it takes a longer time to charge up the capacitor and could affect PWM dimming performance.

Current setting by the sense resistor is as described in [公式 1](#).

$$R_{(SNS)} = \frac{V_{(CS_REG)}}{I_{(LED)}} = 0.98\Omega \quad (4)$$

LED-string maximum forward voltage = $3 \times 2.5 \text{ V} = 7.5 \text{ V}$.

Parallel resistor $R_{(P)}$ is recommended to consume 1/2 of the total current at maximum supply voltage.

$$R_{(P)} = \frac{V_{(SUPPLY)} - V_{(CS_REG)} - V_{(OUT)}}{0.5 \times I_{(LED)}} = \frac{16 - 0.098 - 3 \times 1.9}{0.5 \times 0.1} \approx 200\Omega \quad (5)$$

Total device power consumption is maximum with 16-V input and LEDs at minimal forward voltage.

$$\begin{aligned} P_{(DEV_MAX)} &= \left(V_{(SUPPLY)} - V_{(CS_REG)} - V_{(OUT)} \right) \times \left(I_{(LED)} - \frac{V_{(SUPPLY)} - V_{(CS_REG)} - V_{(OUT)}}{R_{(P)}} \right) + V_{(SUPPLY)} \times I_{(Quiescent)} \\ &= (16 - 0.098 - 3 \times 1.9) \times \left(0.1 - \frac{16 - 0.098 - 3 \times 1.9}{200} \right) + 16 \times 0.00025 = 0.504\text{W} \end{aligned} \quad (6)$$

Resistor $R_{(P)}$ maximum power consumption is at 16-V input.

$$P_{(RP_MAX)} = \frac{\left(V_{(SUPPLY)} - V_{(CS_REG)} - V_{(OUT)} \right)^2}{R_{(P)}} = \frac{(16 - 0.098 - 3 \times 1.9)^2}{200} = 0.52\text{W} \quad (7)$$

Typical Application (接下页)

8.2.2.3 Application Curve

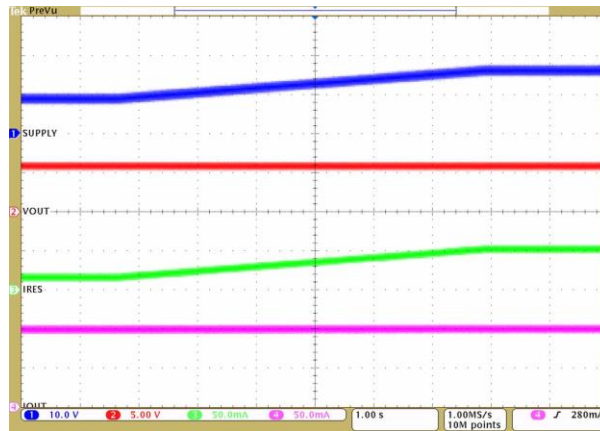

Ch. 1 = $V_{(SUPPLY)}$ Ch. 2 = $V_{(OUT)}$ Ch. 3 = $I_{(P)}$

Ch. 4 = $I_{(LED)}$

Supply voltage increases from 9 V to 16 V

图 22. Constant Output Current With Increasing Supply Voltage

9 Power Supply Recommendations

The TPS92612-Q1 device is qualified for automotive applications. The normal power supply connection is therefore to an automobile electrical system that provides a voltage within the range specified in the [Recommended Operating Conditions](#).

10 Layout

10.1 Layout Guidelines

Thermal dissipation is the primary consideration for TPS92612-Q1 layout. TI recommends good thermal dissipation area beneath the device for better thermal performance.

10.2 Layout Example



图 23. TPS92612-Q1 Example Layout Diagram

11 器件和文档支持

11.1 文档支持

11.1.1 相关文档

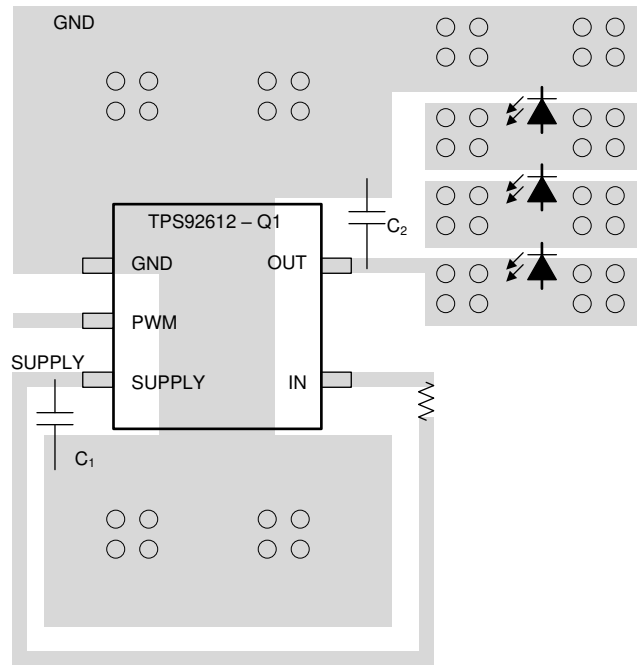
如需相关文档，请参阅：

- 《TPS92610-Q1 汽车单通道线性 LED 驱动器》
- 《TPS92611-Q1 汽车单通道线性 LED 驱动器》
- 《TPS92610-Q1 EVM 用户指南》
- 《如何在汽车外部照明应用中计算 TPS92630-Q1 最大输出 电流》
- 《适用于中央高位刹车灯 (CHMSL) 的汽车线性 LED 驱动器参考设计》
- 《适用于中央高位刹车灯 (CHMSL) 的汽车线性 LED 驱动器参考设计》

11.2 接收文档更新通知

要接收文档更新通知，请导航至 ti.com.cn 上的器件产品文件夹。单击右上角的通知我进行注册，即可每周接收产品信息更改摘要。有关更改的详细信息，请查看任何已修订文档中包含的修订历史记录。

11.3 社区资源

TI E2E™ support forums are an engineer's go-to source for fast, verified answers and design help — straight from the experts. Search existing answers or ask your own question to get the quick design help you need.

Linked content is provided "AS IS" by the respective contributors. They do not constitute TI specifications and do not necessarily reflect TI's views; see TI's [Terms of Use](#).

11.4 商标

E2E is a trademark of Texas Instruments.

All other trademarks are the property of their respective owners.

11.5 静电放电警告



ESD 可能会损坏该集成电路。德州仪器 (TI) 建议通过适当的预防措施处理所有集成电路。如果不遵守正确的处理措施和安装程序，可能会损坏集成电路。

ESD 的损坏小至导致微小的性能降级，大至整个器件故障。精密的集成电路可能更容易受到损坏，这是因为非常细微的参数更改都可能会导致器件与其发布的规格不相符。

11.6 Glossary

[SLYZ022](#) — TI Glossary.

This glossary lists and explains terms, acronyms, and definitions.

12 机械、封装和可订购信息

以下页面包含机械、封装和可订购信息。这些信息是适用于指定器件的最新数据。数据如有变更，恕不另行通知，且不会对此文档进行修订。如需获取此数据表的浏览器版本，请查看左侧的导航面板。

PACKAGING INFORMATION

| Orderable Device | Status (1) | Package Type | Package Drawing | Pins | Package Qty | Eco Plan (2) | Lead finish/ Ball material (6) | MSL Peak Temp (3) | Op Temp (°C) | Device Marking (4/5) | Samples |
|------------------|---------------|--------------|-----------------|------|-------------|-----------------|--------------------------------------|----------------------|--------------|-------------------------|---------|
| TPS92612QDBVRQ1 | ACTIVE | SOT-23 | DBV | 5 | 3000 | RoHS & Green | NIPDAU | Level-2-260C-1 YEAR | -40 to 125 | 1J6F | Samples |

(1) The marketing status values are defined as follows:

ACTIVE: Product device recommended for new designs.

LIFEBUY: TI has announced that the device will be discontinued, and a lifetime-buy period is in effect.

NRND: Not recommended for new designs. Device is in production to support existing customers, but TI does not recommend using this part in a new design.

PREVIEW: Device has been announced but is not in production. Samples may or may not be available.

OBSOLETE: TI has discontinued the production of the device.

(2) **RoHS:** TI defines "RoHS" to mean semiconductor products that are compliant with the current EU RoHS requirements for all 10 RoHS substances, including the requirement that RoHS substance do not exceed 0.1% by weight in homogeneous materials. Where designed to be soldered at high temperatures, "RoHS" products are suitable for use in specified lead-free processes. TI may reference these types of products as "Pb-Free".

RoHS Exempt: TI defines "RoHS Exempt" to mean products that contain lead but are compliant with EU RoHS pursuant to a specific EU RoHS exemption.

Green: TI defines "Green" to mean the content of Chlorine (Cl) and Bromine (Br) based flame retardants meet JS709B low halogen requirements of <=1000ppm threshold. Antimony trioxide based flame retardants must also meet the <=1000ppm threshold requirement.

(3) MSL, Peak Temp. - The Moisture Sensitivity Level rating according to the JEDEC industry standard classifications, and peak solder temperature.

(4) There may be additional marking, which relates to the logo, the lot trace code information, or the environmental category on the device.

(5) Multiple Device Markings will be inside parentheses. Only one Device Marking contained in parentheses and separated by a "-" will appear on a device. If a line is indented then it is a continuation of the previous line and the two combined represent the entire Device Marking for that device.

(6) Lead finish/Ball material - Orderable Devices may have multiple material finish options. Finish options are separated by a vertical ruled line. Lead finish/Ball material values may wrap to two lines if the finish value exceeds the maximum column width.

Important Information and Disclaimer:The information provided on this page represents TI's knowledge and belief as of the date that it is provided. TI bases its knowledge and belief on information provided by third parties, and makes no representation or warranty as to the accuracy of such information. Efforts are underway to better integrate information from third parties. TI has taken and continues to take reasonable steps to provide representative and accurate information but may not have conducted destructive testing or chemical analysis on incoming materials and chemicals. TI and TI suppliers consider certain information to be proprietary, and thus CAS numbers and other limited information may not be available for release.

In no event shall TI's liability arising out of such information exceed the total purchase price of the TI part(s) at issue in this document sold by TI to Customer on an annual basis.

TAPE AND REEL INFORMATION

QUADRANT ASSIGNMENTS FOR PIN 1 ORIENTATION IN TAPE

*All dimensions are nominal

| Device | Package Type | Package Drawing | Pins | SPQ | Reel Diameter (mm) | Reel Width W1 (mm) | A0 (mm) | B0 (mm) | K0 (mm) | P1 (mm) | W (mm) | Pin1 Quadrant |
|-----------------|--------------|-----------------|------|------|--------------------|--------------------|---------|---------|---------|---------|--------|---------------|
| TPS92612QDBVRQ1 | SOT-23 | DBV | 5 | 3000 | 180.0 | 8.4 | 3.2 | 3.2 | 1.4 | 4.0 | 8.0 | Q3 |

TAPE AND REEL BOX DIMENSIONS



*All dimensions are nominal

| Device | Package Type | Package Drawing | Pins | SPQ | Length (mm) | Width (mm) | Height (mm) |
|-----------------|--------------|-----------------|------|------|-------------|------------|-------------|
| TPS92612QDBVRQ1 | SOT-23 | DBV | 5 | 3000 | 210.0 | 185.0 | 35.0 |

EXAMPLE BOARD LAYOUT

DBV0005A

SOT-23 - 1.45 mm max height

SMALL OUTLINE TRANSISTOR

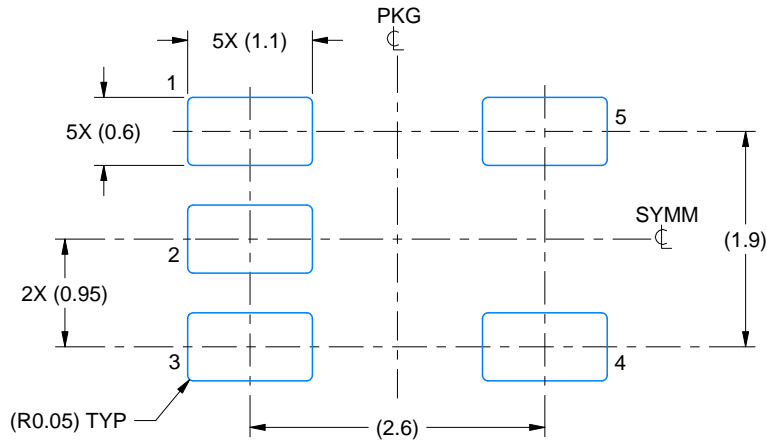

LAND PATTERN EXAMPLE
EXPOSED METAL SHOWN
SCALE:15X

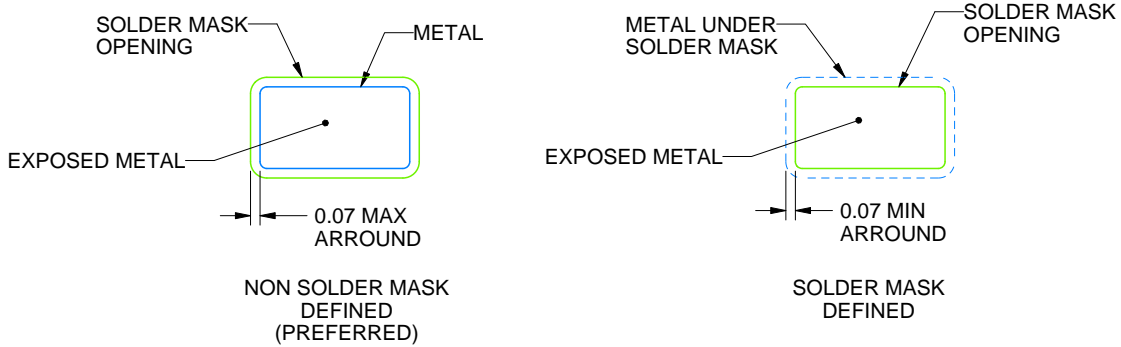

SOLDER MASK DETAILS

4214839/F 06/2021

NOTES: (continued)

- 5. Publication IPC-7351 may have alternate designs.
- 6. Solder mask tolerances between and around signal pads can vary based on board fabrication site.

EXAMPLE STENCIL DESIGN

DBV0005A

SOT-23 - 1.45 mm max height

SMALL OUTLINE TRANSISTOR

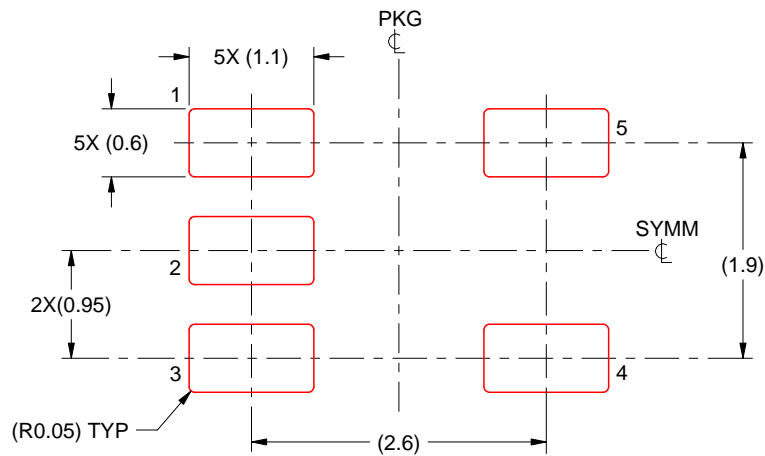

SOLDER PASTE EXAMPLE
BASED ON 0.125 mm THICK STENCIL
SCALE:15X

4214839/F 06/2021

NOTES: (continued)

7. Laser cutting apertures with trapezoidal walls and rounded corners may offer better paste release. IPC-7525 may have alternate design recommendations.
8. Board assembly site may have different recommendations for stencil design.

重要声明和免责声明

TI“按原样”提供技术和可靠性数据（包括数据表）、设计资源（包括参考设计）、应用或其他设计建议、网络工具、安全信息和其他资源，不保证没有瑕疵且不做任何明示或暗示的担保，包括但不限于对适销性、某特定用途方面的适用性或不侵犯任何第三方知识产权的暗示担保。

这些资源可供使用 TI 产品进行设计的熟练开发人员使用。您将自行承担以下全部责任：(1) 针对您的应用选择合适的 TI 产品，(2) 设计、验证并测试您的应用，(3) 确保您的应用满足相应标准以及任何其他功能安全、信息安全、监管或其他要求。

这些资源如有变更，恕不另行通知。TI 授权您仅可将这些资源用于研发本资源所述的 TI 产品的应用。严禁对这些资源进行其他复制或展示。您无权使用任何其他 TI 知识产权或任何第三方知识产权。您应全额赔偿因在这些资源的使用中对 TI 及其代表造成的任何索赔、损害、成本、损失和债务，TI 对此概不负责。

TI 提供的产品受 [TI 的销售条款](#) 或 [ti.com](#) 上其他适用条款/TI 产品随附的其他适用条款的约束。TI 提供这些资源并不会扩展或以其他方式更改 TI 针对 TI 产品发布的适用的担保或担保免责声明。

TI 反对并拒绝您可能提出的任何其他或不同的条款。

邮寄地址：Texas Instruments, Post Office Box 655303, Dallas, Texas 75265
Copyright © 2021，德州仪器 (TI) 公司