

BUF16821-Q1 可编程伽马电压生成器和具有集成型 2 组存储器的 VCOM 校准器

1 特性

- 具有符合 AEC-Q100 标准的以下结果：
 - 温度等级 3: -40°C 至 85°C
 - 人体模型 (HBM) 静电放电 (ESD) 分类等级 2
 - 充电器件模型 (CDM) ESD 分类等级 C4B
- 16 通道 P 伽马, 2 通道 P-VCOM, 10 位分辨率
- 16x 可重写非易失性存储器
- 两个独立的引脚可选存储器组
- 轨至轨输出：
 - 300mV (最小值) 电源轨摆幅 (10mA)
 - > 300mA (最大值) I_{OUT}
- 电源电压: 9V 至 20V
- 数字电源: 2V 至 5.5V
- I²C™ 接口: 支持 400kHz 和 2.7MHz

2 应用范围

TFT-LCD 基准驱动器

功能方框图

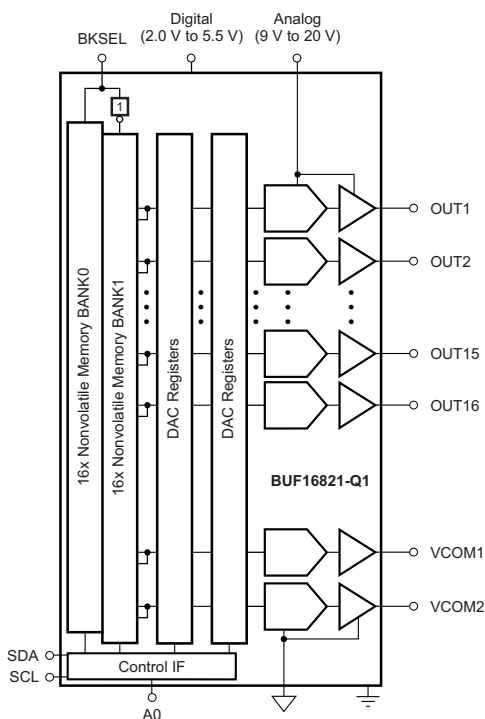

3 说明

BUF16821-Q1 提供 16 条可编程伽马通道, 以及两个可编程 VCOM 通道。最终的伽马和 VCOM 值可被存储在片上、非易失性存储器中。为了应对编程错误时或使液晶显示屏 (LCD) 面板重新开始工作, 此器件支持多达 16 个对片上存储器的写操作。

此器件具有两个独立的存储器组, 可实现两个不同伽马曲线的同时存储, 从而使伽马曲线之间的切换更加便捷。所有伽马和 VCOM 通道提供一个轨到轨输出, 此输出在 10mA 负载时, 通常在任一电源轨的 150mV 内摆动。可使用一个 I²C 接口对所有通道进行编程, 这个接口支持高达 400kHz 的标准运行, 以及高达 2.7MHz 的高速数据传输。

此器件使用德州仪器 (TI) 专有的、最先进的高压 CMOS 工艺制造。这一工艺提供高达 20V 的高密度逻辑和高电源电压运行。此器件采用带散热片薄型小外形尺寸 (HTSSOP)-28 PowerPAD™ 封装, 并且在 -40°C 至 +85°C 的温度范围内额定运行。

器件信息⁽¹⁾

产品型号	封装	封装尺寸 (标称值)
BUF16821-Q1	HTSSOP (28)	9.70mm x 4.40mm

(1) 要了解所有可用封装, 请见数据表末尾的可订购产品附录。



目录

1	特性	1	7.4	Device Functional Modes	19
2	应用范围	1	7.5	Programming	20
3	说明	1	7.6	Register Maps	24
4	修订历史记录	2	8	Application and Implementation	25
5	Pin Configuration and Functions	3	8.1	Application Information	25
6	Specifications	5	8.2	Typical Application	25
6.1	Absolute Maximum Ratings	5	9	Power Supply Recommendations	26
6.2	Handling Ratings	5	10	Layout	27
6.3	Recommended Operating Conditions	5	10.1	Layout Guidelines	27
6.4	Thermal Information	5	10.2	Layout Example	29
6.5	Electrical Characteristics	6	11	器件和文档支持	30
6.6	Timing Requirements	7	11.1	文档支持	30
6.7	Typical Characteristics	8	11.2	Trademarks	30
7	Detailed Description	10	11.3	Electrostatic Discharge Caution	30
7.1	Overview	10	11.4	Glossary	30
7.2	Functional Block Diagram	10	12	机械封装和可订购信息	30
7.3	Feature Description	10			

4 修订历史记录

日期	修订版本	注释
2014 年 5 月	*	最初发布。

Related Products

FEATURES	DEVICE
22-channel gamma correction buffer	BUF22821
12-channel gamma correction buffer	BUF12800
18-, 20-channel programmable buffer, 10-bit, VCOM	BUF20800
18-, 20-channel programmable buffer with memory	BUF20820
Programmable VCOM driver	BUF01900
18-V supply, traditional gamma buffers	BUF11704
22-V supply, traditional gamma buffers	BUF11705

5 Pin Configuration and Functions

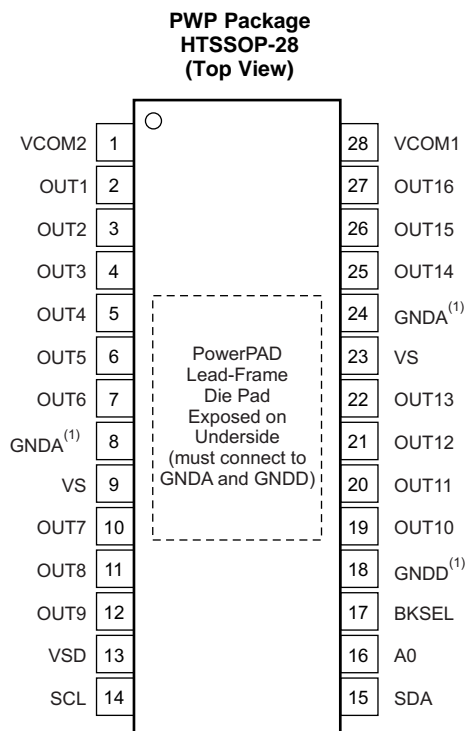

(1) GNDA and GNDD must be connected together.

Pin Functions

PIN		DESCRIPTION
NO.	NAME	
1	VCOM2	VCOM channel 2
2	OUT1	DAC output 1
3	OUT2	DAC output 2
4	OUT3	DAC output 3
5	OUT4	DAC output 4
6	OUT5	DAC output 5
7	OUT6	DAC output 6
8	GNDA	Analog ground; must be connected to digital ground (GNDD).
9	VS	VS connected to analog supply
10	OUT7	DAC output 7
11	OUT8	DAC output 8
12	OUT9	DAC output 9
13	VSD	Digital supply; connect to logic supply
14	SCL	Serial clock input; open-drain, connect to pull-up resistor.
15	SDA	Serial data I/O; open-drain, connect to pull-up resistor.
16	A0	A0 address pin for I ² C address; connect to either logic 1 or logic 0; refer to Table 2 .
17	BKSEL	Selects memory bank 0 or 1; connect to either logic 1 to select bank 1 or logic 0 to select bank 0.
18	GNDD	Digital ground; must be connected to analog ground at the BUF16821-Q1.
19	OUT10	DAC output 10
20	OUT11	DAC output 11
21	OUT12	DAC output 12
22	OUT13	DAC output 13
23	VS	VS connected to analog supply
24	GNDA	Analog ground; must be connected to digital ground (GNDD).
25	OUT14	DAC output 14
26	OUT15	DAC output 15
27	OUT16	DAC output 16
28	VCOM1	VCOM channel 1

6 Specifications

6.1 Absolute Maximum Ratings

over operating free-air temperature range (unless otherwise noted)⁽¹⁾

		MIN	MAX	UNIT
V _S	Supply voltage		22	V
DVDD	Digital power supply (VSD pin)		6	V
	Digital input pins	SCL, SDA, AO, BKSEL: voltage		V
		SCL, SDA, AO, BKSEL: current		mA
	Output pins, OUT1 through OUT16, VCOM1 and VCOM2 ⁽²⁾	(V ⁻) – 0.5	(V ⁺) + 0.5	V
	Output short-circuit ⁽³⁾	Continuous		
	Ambient operating temperature	–40	95	°C
T _J	Junction temperature		125	°C

(1) Stresses beyond those listed under *Absolute Maximum Ratings* may cause permanent damage to the device. These are stress ratings only, which do not imply functional operation of the device at these or any other conditions beyond those indicated under *Recommended Operating Conditions*. Exposure to absolute-maximum-rated conditions for extended periods may affect device reliability.

(2) See the [Output Protection](#) section.

(3) Short-circuit to ground, one amplifier per package.

6.2 Handling Ratings

		MIN	MAX	UNIT		
T _{stg}	Storage temperature range	–65	150	°C		
V _(ESD)	Electrostatic discharge	Human body model (HBM), per AEC Q100-002 ⁽¹⁾		V		
		Charged device model (CDM), per AEC Q100-011	Corner pins (1, 14, 15, and 28)		–750	750
			Other pins		–500	500

(1) AEC Q100-002 indicates HBM stressing is done in accordance with the ANSI/ESDA/JEDEC JS-001 specification.

6.3 Recommended Operating Conditions

over operating free-air temperature range (unless otherwise noted)

		MIN	NOM	MAX	UNIT
V _S	Supply voltage	9.0	18.0	20.0	V
DVDD	Digital power supply (VSD pin)	2.0	3.3	5.5	V

6.4 Thermal Information

THERMAL METRIC ⁽¹⁾		BUF16821-Q1	UNIT
		PWP (HTSSOP)	
		28 PINS	
R _{θJA}	Junction-to-ambient thermal resistance	34.3	°C/W
R _{θJC(top)}	Junction-to-case (top) thermal resistance	19.9	
R _{θJB}	Junction-to-board thermal resistance	17.4	
Ψ _{JT}	Junction-to-top characterization parameter	0.7	
Ψ _{JB}	Junction-to-board characterization parameter	17.2	
R _{θJC(bot)}	Junction-to-case (bottom) thermal resistance	3.0	

(1) For more information about traditional and new thermal metrics, see the *IC Package Thermal Metrics* application report, [SPRA953](#).

6.5 Electrical Characteristics

At $T_A = 25^\circ\text{C}$, $V_S = 18\text{ V}$, $V_{SD} = 2\text{ V}$, $R_L = 1.5\text{ k}\Omega$ connected to ground, and $C_L = 200\text{ pF}$, unless otherwise noted.

PARAMETER	CONDITIONS	MIN	TYP	MAX	UNIT
ANALOG GAMMA BUFFER CHANNELS					
Reset value	Code 512		9		V
OUT 1–16 output swing: high	Code = 1023, sourcing 10 mA, $T_A = -40^\circ\text{C}$ to 85°C	17.7	17.85		V
OUT 1–16 output swing: low	Code = 0, sinking 10 mA, $T_A = -40^\circ\text{C}$ to 85°C		0.07	0.3	V
VCOM1, 2 output swing: high	Code = 1023, sourcing 100 mA, $T_A = -40^\circ\text{C}$ to 85°C	13	16.2		V
VCOM1, 2 output swing: low	Code = 0, sinking 100 mA, $T_A = -40^\circ\text{C}$ to 85°C		0.6	2	V
Continuous output current ⁽¹⁾			30		mA
Output accuracy			± 20	± 50	mV
Output accuracy over temperature	Code 512, $T_A = -40^\circ\text{C}$ to 85°C		± 25		$\mu\text{V}/^\circ\text{C}$
INL	Integral nonlinearity		0.3		LSB
DNL	Differential nonlinearity		0.3		LSB
$\Delta V_{O(\Delta I_O)}$	Load regulation, 10 mA	Code 512 or $V_{CC} / 2$, $I_{OUT} = 5\text{-mA}$ to -5-mA step	0.5	1.5	mV/mA
OTP MEMORY					
Number of OTP write cycles				16	Cycles
Memory retention			100		Years
ANALOG POWER SUPPLY					
Operating range		9		20	V
$I_{CC(\text{tot})}$	Total analog supply current	Outputs at reset values, no load	12	14	mA
	$I_{CC(\text{tot})}$ over temperature	$T_A = -40^\circ\text{C}$ to 85°C		18	mA
DIGITAL					
V_{IH}	Logic 1 high input voltage		$0.7 \times V_{SD}$		V
V_{IL}	Logic 0 low input voltage			$0.3 \times V_{SD}$	V
V_{OL}	Logic 0 low output voltage	$I_{SINK} = 3\text{ mA}$	0.15	0.4	V
	Input leakage		± 0.01	± 10	μA
f_{CLK}	Clock frequency	Standard, fast mode, $T_A = -40^\circ\text{C}$ to 85°C		400	kHz
		High-speed mode, $T_A = -40^\circ\text{C}$ to 85°C		2.7	MHz
DIGITAL POWER SUPPLY					
DVDD	Digital power supply (VSD pin)		2.0	5.5	V
I_{SD}	Digital supply current ⁽¹⁾	Outputs at reset values, no load, two-wire bus inactive	115	150	μA
	I_{SD} over temperature	$T_A = -40^\circ\text{C}$ to 85°C	115		μA
TEMPERATURE RANGE					
	Specified range		-40	85	$^\circ\text{C}$
	Operating range	Junction temperature $< 125^\circ\text{C}$	-40	95	$^\circ\text{C}$
	Storage range		-65	150	$^\circ\text{C}$
$R_{\theta JA}$	Thermal resistance, HTSSOP-28 ⁽¹⁾⁽²⁾		40		$^\circ\text{C}/\text{W}$

(1) Observe maximum power dissipation.

(2) Thermal pad is attached to the printed circuit board (PCB), 0-lfm airflow, and 76-mm x 76-mm copper area.

6.6 Timing Requirements

PARAMETER		FAST MODE		HIGH-SPEED MODE		UNIT
		MIN	MAX	MIN	MAX	
$f_{(SCL)}$	SCL operating frequency	0.001	0.4	0.001	2.7	MHz
$t_{(BUF)}$	Bus free time between stop and start conditions	1300		230		ns
$t_{(HDSTA)}$	Hold time after repeated start condition. After this period, the first clock is generated.	600		230		ns
$t_{(SUSTA)}$	Repeated start condition setup time	600		230		ns
$t_{(SUSTO)}$	Stop condition setup time	600		230		ns
$t_{(HDDAT)}$	Data hold time	20	900	20	130	ns
$t_{(SUDAT)}$	Data setup time	100		20		ns
$t_{(LOW)}$	SCL clock low period	1300		230		ns
$t_{(HIGH)}$	SCL clock high period	600		60		ns
$t_{R(SDA)}$, $t_{F(SDA)}$	Data rise and fall time		300		80	ns
$t_{R(SCL)}$, $t_{F(SCL)}$	Clock rise and fall time		300		40	ns
t_R	Clock and data rise time for SCLK \leq 100 kHz		1000			ns

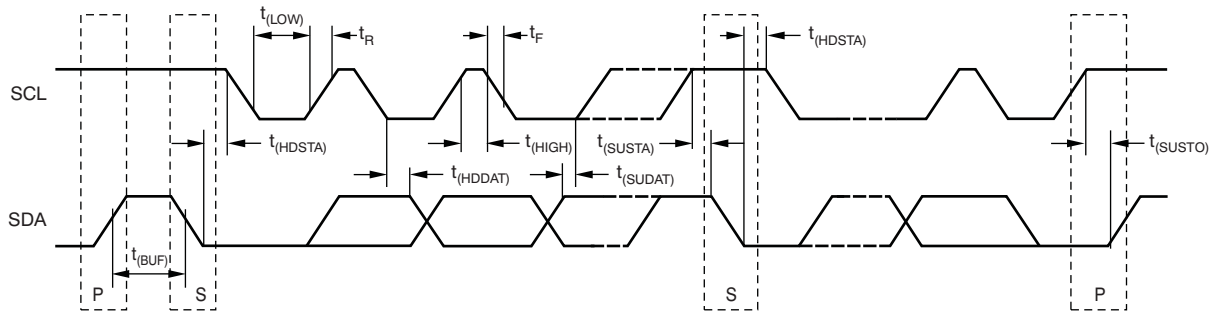

Figure 1. Timing Requirements Diagram

6.7 Typical Characteristics

At $T_A = 25^\circ\text{C}$, $V_S = 18\text{ V}$, $V_{SD} = 2\text{ V}$, $R_L = 1.5\text{ k}\Omega$ connected to ground, and $C_L = 200\text{ pF}$, unless otherwise noted.

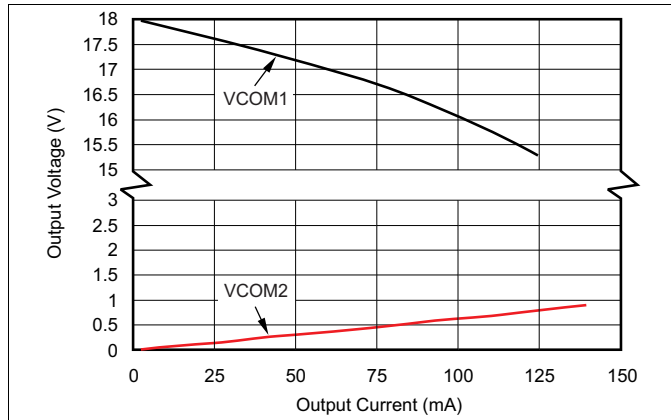

Figure 2. Output Voltage vs Output Current (VCOM1 and VCOM2)

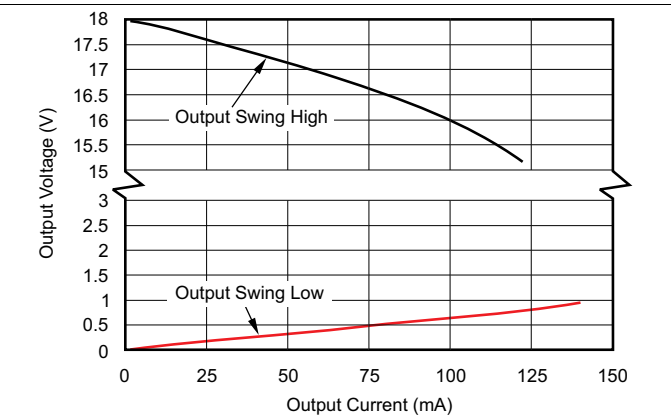

Figure 3. Output Voltage vs Output Current (Channels 1–16)

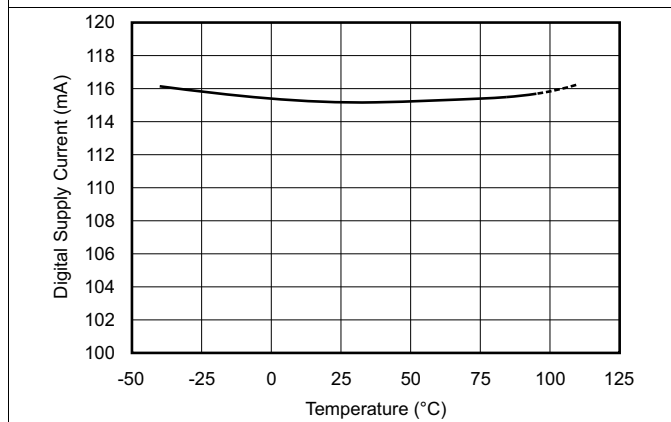

Figure 4. Digital Supply Current vs Temperature

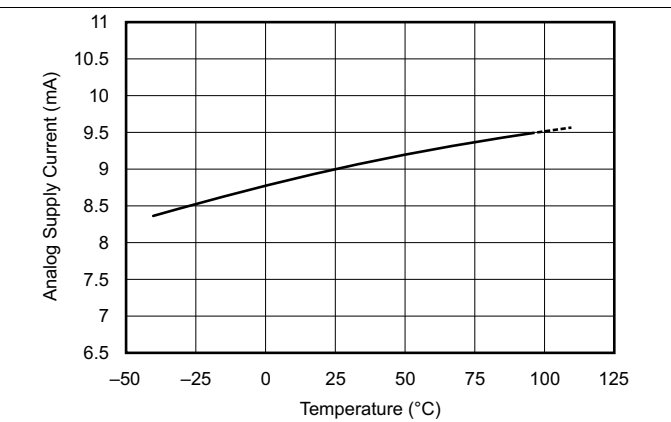

Figure 5. Analog Supply Current vs Temperature

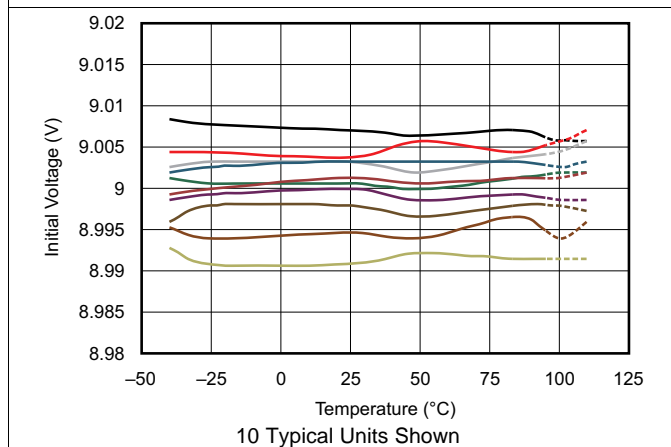

Figure 6. Output Voltage vs Temperature

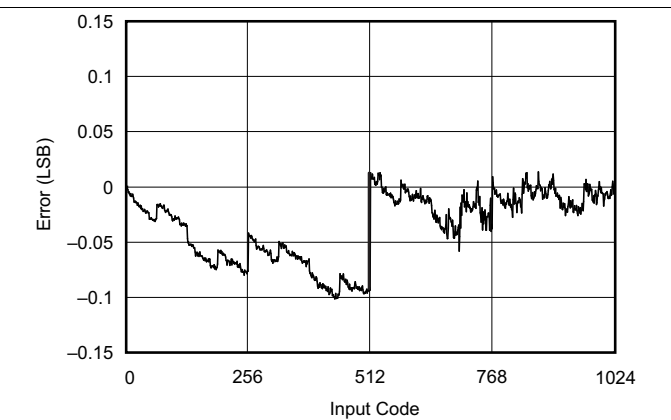

Figure 7. Differential Linearity Error

Typical Characteristics (continued)

At $T_A = 25^\circ\text{C}$, $V_S = 18\text{ V}$, $V_{SD} = 2\text{ V}$, $R_L = 1.5\text{ k}\Omega$ connected to ground, and $C_L = 200\text{ pF}$, unless otherwise noted.

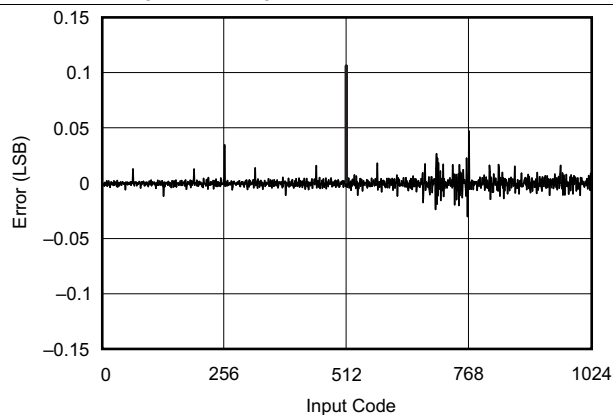

Figure 8. Integral Linearity Error

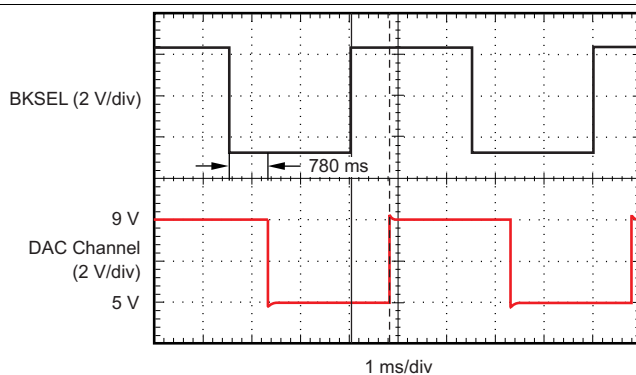

Figure 9. BKSEL Switching Time Delay

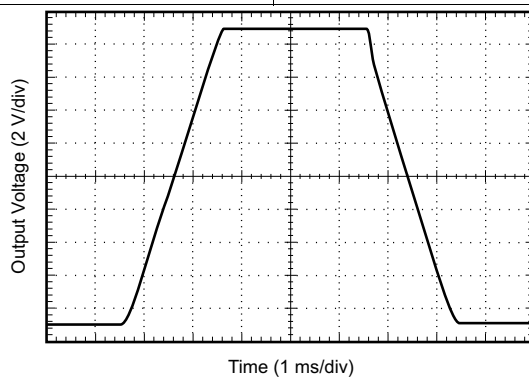

Figure 10. Large-Signal Step Response

7 Detailed Description

7.1 Overview

The BUF16821-Q1 programmable voltage reference allows fast and easy adjustment of 16 programmable gamma reference outputs and two VCOM outputs, each with 10-bit resolution. The device is programmed through a high-speed, I²C interface. The final gamma and VCOM values can be stored in the onboard, nonvolatile memory. To allow for programming errors or liquid crystal display (LCD) panel rework, the device supports up to 16 write operations to the onboard memory. The device has two separate memory banks, allowing simultaneous storage of two different gamma curves to facilitate dynamic switching between gamma curves. Figure 19 illustrates a typical configuration of the device.

7.2 Functional Block Diagram

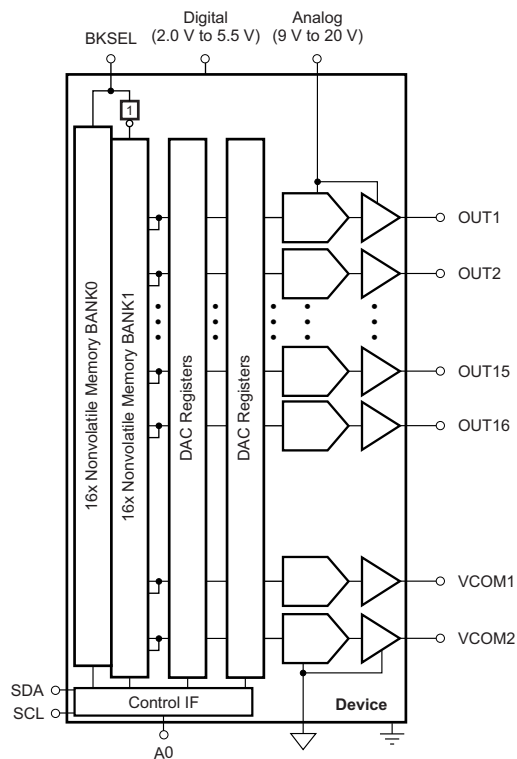

7.3 Feature Description

7.3.1 Two-Wire Bus Overview

The device communicates over an industry-standard, two-wire interface to receive data in slave mode. This standard uses a two-wire, open-drain interface that supports multiple devices on a single bus. Bus lines are driven to a logic low level only. The device that initiates the communication is called a *master*, and the devices controlled by the master are *slaves*. The master generates the serial clock on the clock signal line (SCL), controls the bus access, and generates the start and stop conditions.

To address a specific device, the master initiates a start condition by pulling the data signal line (SDA) from a high to a low logic level while SCL is high. All slaves on the bus shift in the slave address byte on the SCL rising edge, with the last bit indicating whether a read or write operation is intended. During the ninth clock pulse, the slave being addressed responds to the master by generating an acknowledge and pulling SDA low.

Data transfer is then initiated and eight bits of data are sent, followed by an acknowledge bit. During data transfer, SDA must remain stable while SCL is high. Any change in SDA while SCL is high is interpreted as a start or stop condition.

Feature Description (continued)

When all data are transferred, the master generates a stop condition, indicated by pulling SDA from low to high while SCL is high. The device can act only as a slave device and therefore never drives SCL. SCL is an input only for the BUF16821-Q1.

7.3.2 Data Rates

The two-wire bus operates in one of three speed modes:

- Standard: allows a clock frequency of up to 100 kHz;
- Fast: allows a clock frequency of up to 400 kHz; and
- High-speed mode (also called Hs mode): allows a clock frequency of up to 2.7 MHz.

The device is fully compatible with all three modes. No special action is required to use the device in standard or fast modes, but high-speed mode must be activated. To activate high-speed mode, send a special address byte of 00001 xxx, with SCL ≤ 400 kHz, following the start condition; where xxx are bits unique to the Hs-capable master, which can be any value. This byte is called the Hs master code. [Table 1](#) provides a reference for the high-speed mode command code. (Note that this configuration is different from normal address bytes—the low bit does not indicate read or write status.) The device responds to the high-speed command regardless of the value of these last three bits. The device does not acknowledge this byte; the communication protocol prohibits acknowledgment of the Hs master code. Upon receiving a master code, the device switches on its Hs mode filters, and communicates at up to 2.7 MHz. Additional high-speed transfers may be initiated without resending the Hs mode byte by generating a repeat start without a stop. The device switches out of Hs mode with the next stop condition.

Table 1. Quick-Reference of Command Codes

COMMAND	CODE
General-call reset	Address byte of 00h followed by a data byte of 06h.
High-speed mode	00001xxx, with SCL ≤ 400 kHz; where xxx are bits unique to the Hs-capable master. This byte is called the Hs master code.

7.3.3 General-Call Reset and Power-Up

The device responds to a general-call reset, which is an address byte of 00h (0000 0000) followed by a data byte of 06h (0000 0110). The device acknowledges both bytes. [Table 1](#) provides a reference for the general-call reset command code. Upon receiving a general-call reset, the device performs a full internal reset, as though it was powered off and then on. The device always acknowledges the general-call address byte of 00h (0000 0000), but does not acknowledge any general-call data bytes other than 06h (0000 0110).

The device automatically performs a reset when powered up. As part of the reset, the device is configured for all outputs to change to the last programmed nonvolatile memory values, or 1000000000 if the nonvolatile memory values are not programmed.

7.3.4 Output Voltage

The buffer output values are determined by the analog supply voltage (V_S) and the decimal value of the binary input code used to program that buffer. The value is calculated using [Equation 1](#):

$$V_{OUT} = V_S \times \left(\frac{CODE_{10}}{1024} \right) \quad (1)$$

The device outputs are capable of a full-scale voltage output change in typically 5 μs; no intermediate steps are required.

7.3.5 Updating the DAC Output Voltages

Updating the digital-to-analog converter (DAC) and the VCOM **register** is not the same as updating the DAC and VCOM **output voltage** because the device features a double-buffered register structure. There are two methods for updating the DAC and VCOM output voltages.

Method 1: Method 1 is used when the DAC and VCOM output voltage are desired to change immediately after writing to a DAC register. For each write transaction, the master sets data bit 15 to a 1. The DAC and VCOM output voltage update occurs after receiving the 16th data bit for the currently-written register.

Method 2: Method 2 is used when all DAC and VCOM output voltages are desired to change at the same time. First, the master writes to the desired DAC and VCOM channels with data bit 15 a 0. Then, when writing the last desired DAC and VCOM channel, the master sets data bit 15 to a 1. All DAC and VCOM channels are updated at the same time after receiving the 16th data bit.

7.3.6 DIE_ID and DIE_REV Registers

The user can verify the presence of the BUF16821-Q1 in the system by reading from address 111101. When read at this address, the BUF16821-Q1A returns *0101100100100111* and the BUF16821-Q1B returns *0101100100100100*.

The user can also determine the die revision of the device by reading from register 111100. The device returns *0000000000000000* when a RevA die is present. RevB is designated by *0000000000000001*, and so on.

7.3.7 Read and Write Operations

Read and write operations can be done for a single DAC and VCOM or for multiple DACs and VCOMs. Writing to a DAC and VCOM register differs from writing to the nonvolatile memory. Bits D15–D14 of the most significant byte of data determine if data are written to the DAC and VCOM register or the nonvolatile memory.

7.3.7.1 Read and Write: DAC and VCOM Register (Volatile Memory)

The device is able to read from a single DAC and VCOM, or multiple DACs and VCOMs, or write to the register of a single DAC and VCOM, or multiple DACs and VCOMs in a single communication transaction. The DAC pointer addresses begin with 000000 (which corresponds to OUT1) through 001111 (which corresponds to OUT16). Addresses 010010 and 010011 are VCOM1 and VCOM2, respectively.

Write commands are performed by setting the read and write bit low. Setting the read or write bit high performs a read transaction.

7.3.7.2 Writing: DAC and VCOM Register (Volatile Memory)

To write to a single DAC and VCOM register:

1. Send a start condition on the bus.
2. Send the device address and read and write bit = low. The device acknowledges this byte.
3. Send a DAC and VCOM pointer address byte. Set bit D7 = 0 and D6 = 0. Bits D5–D0 are the DAC and VCOM address. Although the device acknowledges 000000 through 010111, data are stored and returned only from these addresses:
 - 000000 through 001111
 - 010010 through 010011
 The device returns *0000* for reads from 010000 through 010001, and 010100 through 010111. See [Table 4](#) for valid DAC and VCOM addresses.
4. Send two bytes of data for the specified register. Begin by sending the most significant byte first (bits D15–D8, of which only bits D9 and D8 are used, and bits D15–D14 must not be 01), followed by the least significant byte (bits D7–D0). The register is updated after receiving the second byte.
5. Send a stop or start condition on the bus.

The device acknowledges each data byte. If the master terminates communication early by sending a stop or start condition on the bus, the specified register is not updated. Updating the DAC and VCOM register is not the same as updating the DAC and VCOM output voltage; see the [Updating the DAC Output Voltages](#) section.

The process of updating multiple DAC and VCOM registers begins the same as when updating a single register. However, instead of sending a stop condition after writing the addressed register, the master continues to send data for the next register. The device automatically and sequentially steps through subsequent registers as additional data are sent. The process continues until all desired registers are updated or a stop or start condition is sent.

To write to multiple DAC and VCOM registers:

1. Send a start condition on the bus.
2. Send the device address and read or write bit = low. The device acknowledges this byte.
3. Send either the OUT1 pointer address byte to start at the first DAC, or send the pointer address byte for whichever DAC and VCOM is the first in the sequence of DACs and VCOMs to be updated. The device begins with this DAC and VCOM and steps through subsequent DACs and VCOMs in sequential order.
4. Send the bytes of data; begin by sending the most significant byte (bits D15–D8, of which only bits D9 and D8 have meaning, and bits D15–D14 must not be 01), followed by the least significant byte (bits D7–D0). The first two bytes are for the DAC and VCOM addressed in the previous step. The DAC and VCOM register is automatically updated after receiving the second byte. The next two bytes are for the following DAC and VCOM. That DAC and VCOM register is updated after receiving the fourth byte. This process continues until the registers of all following DACs and VCOMs are updated. The device continues to accept data for a total of 18 DACs; however, the two data sets following the 16th data set are meaningless. The 19th and 20th data sets apply to VCOM1 and VCOM2. The write disable bit cannot be accessed using this method. This bit must be written to using *the write to a single DAC register procedure*.
5. Send a stop or start condition on the bus.

The device acknowledges each byte. To terminate communication, send a stop or start condition on the bus. Only DAC registers that have received both bytes of data are updated.

7.3.7.3 Reading: DAC, VCOM, Other Register (Volatile Memory)

Reading a register returns the data stored in that DAC, VCOM, other register.

To read a single DAC, VCOM, other register:

1. Send a start condition on the bus.
2. Send the device address and read or write bit = low. The device acknowledges this byte.
3. Send the DAC, VCOM, other pointer address byte. Set bit D7 = 0 and D6 = 0; bits D5–D0 are the DAC, VCOM, other address. Note that the device stores and returns data only from these addresses:
 - 000000 through 001111
 - 010010
 - 010011
 - 111100 through 111111

The device returns 0000 for reads from 010000 and 010001, and 010100 through 010111. See [Table 4](#) for valid DAC, VCOM, other addresses.
4. Send a start or stop and start condition.
5. Send the correct device address and read or write bit = high. The device acknowledges this byte.
6. Receive two bytes of data. These bytes are for the specified register. The most significant byte (bits D15–D8) is received first; next is the least significant byte (bits D7–D0). In the case of DAC and VCOM channels, bits D15–D10 have no meaning.
7. Acknowledge after receiving the first byte.
8. Send a stop or start condition on the bus or do not acknowledge the second byte to end the read transaction.

Communication may be terminated by sending a premature stop or start condition on the bus, or by not acknowledging.

To read multiple registers:

1. Send a start condition on the bus.
2. Send the device address and read or write bit = low. The device acknowledges this byte.
3. Send either the OUT1 pointer address byte to start at the first DAC, or send the pointer address byte for whichever register is the first in the sequence of DACs and VCOMs to be read. The device begins with this DAC and VCOM and steps through subsequent DACs and VCOMs in sequential order.
4. Send a start or stop and start condition on the bus.
5. Send the correct device address and read or write bit = high. The device acknowledges this byte.

6. Receive two bytes of data. These bytes are for the specified DAC and VCOM. The first received byte is the most significant byte (bits D15–D8; only bits D9 and D8 have meaning), next is the least significant byte (bits D7–D0).
7. Acknowledge after receiving each byte of data.
8. When all desired DACs are read, send a stop or start condition on the bus.

Communication may be terminated by sending a premature stop or start condition on the bus, or by not sending the acknowledge bit. Reading the DieID, DieRev, and MaxBank registers is not supported in this mode of operation (these values must be read using the single register read method).

7.3.7.4 Write: Nonvolatile Memory for the DAC Register

The device is able to write to the nonvolatile memory of a single DAC and VCOM in a single communication transaction. In contrast to the [BUF20820](#), writing to multiple nonvolatile memory words in a single transaction is not supported. Valid DAC and VCOM pointer addresses begin with 000000 (which corresponds to OUT1) through 001111 (which corresponds to OUT16). Addresses 010010 and 010011 are VCOM1 and VCOM2, respectively.

When programming the nonvolatile memory, the analog supply voltage must be between 9 V and 20 V. Write commands are performed by setting the read or write bit low.

To write to a single nonvolatile register:

1. Send a start condition on the bus.
2. Send the device address and read or write bit = low. The device acknowledges this byte. Although the device acknowledges 000000 through 010111, data are stored and returned only from these addresses:
 - 000000 through 001111
 - 010010 and 010011

The device returns 0000 for reads from 010000 through 010001, and 010100 through 010111. See [Table 4](#) for DAC and VCOM addresses.

3. Send a DAC and VCOM pointer address byte. Set bit D7 = 0 and D6 = 0. Bits D5–D0 are the DAC and VCOM address.
4. Send two bytes of data for the nonvolatile register of the specified DAC and VCOM. Begin by sending the most significant byte first (bits D15–D8, of which only bits D9 and D8 are data bits, and bits D15–D14 must be 01), followed by the least significant byte (bits D7–D0). The register is updated after receiving the second byte.
5. Send a stop condition on the bus.

The device acknowledges each data byte. If the master terminates communication early by sending a stop or start condition on the bus, the specified nonvolatile register is not updated. Writing a nonvolatile register also updates the DAC and VCOM register and output voltage.

The DAC and VCOM register and DAC and VCOM output voltage are updated immediately, while the programming of the nonvolatile memory takes up to 250 μ s. When a nonvolatile register write command is issued, no communication with the device should take place for at least 250 μ s. Writing or reading over the serial interface while the nonvolatile memory is being written jeopardizes the integrity of the data being stored.

7.3.7.5 Read: Nonvolatile Memory for the DAC Register

To read the data present in nonvolatile register for a particular DAC and VCOM channel, the master must first issue a general acquire command, or a single acquire command with the appropriate DAC and VCOM channel chosen. This action updates both the DAC and VCOM registers and DAC and VCOM output voltages. The master may then read from the appropriate DAC and VCOM register as described earlier.

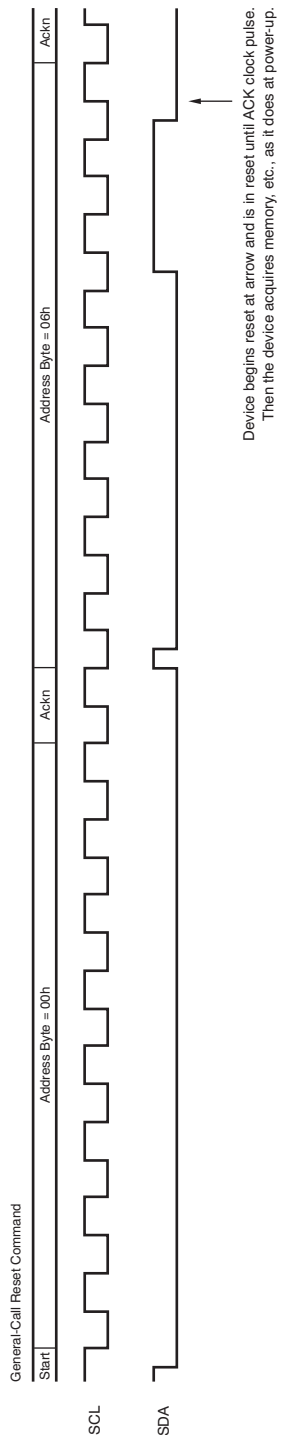

Figure 15. General-Call Reset Timing

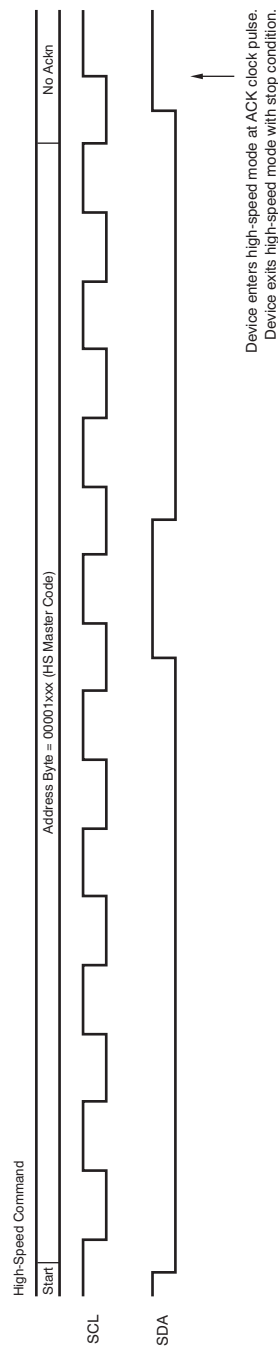

Figure 16. High-Speed Mode Timing

7.3.8 Output Protection

The device output stages can safely source and sink the current levels indicated in [Figure 2](#) and [Figure 3](#). However, there are other modes where precautions must be taken to prevent the output stages from being damaged by excessive current flow. The outputs (OUT1 through OUT16, VCOM1 and VCOM2) include electrostatic discharge (ESD) protection diodes, as shown in [Figure 17](#). Normally, these diodes do not conduct and are passive during typical device operation. Unusual operating conditions can occur where the diodes may conduct, potentially subjecting them to high, even damaging current levels. These conditions are most likely to occur when a voltage applied to an output exceeds $(V_S) + 0.5\text{ V}$, or drops below $\text{GND} - 0.5\text{ V}$.

One common scenario where this condition can occur is when the output pin is connected to a sufficiently large capacitor and the device power-supply source (V_S) is suddenly removed. Removing the power-supply source allows the capacitor to discharge through the current-steering diodes. The energy released during the high current flow period causes the power dissipation limits of the diode to be exceeded. Protection against the high current flow may be provided by placing current-limiting resistors in series with the output; see [Figure 19](#). Select a resistor value that restricts the current level to the maximum rating for the particular pin.

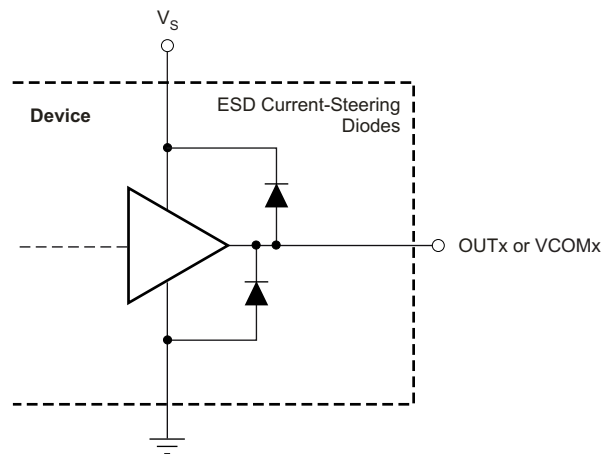

Figure 17. Output Pins ESD Protection Current-Steering Diodes

7.4 Device Functional Modes

7.4.1 End-User Selected Gamma Control

The device is well-suited for providing two levels of gamma control by using the BKSEL pin because the device has two banks of nonvolatile memory, as shown in Figure 18. When the state of the BKSEL pin changes, the device updates all 18 programmable buffer outputs simultaneously after 750 μ s (\pm 80 μ s).

To update all 18 programmable output voltages simultaneously via hardware, toggle the BKSEL pin to switch between gamma curve 0 (stored in Bank0) and gamma curve 1 (stored in Bank1).

All DAC and VCOM registers and output voltages are updated simultaneously after approximately 750 μ s.

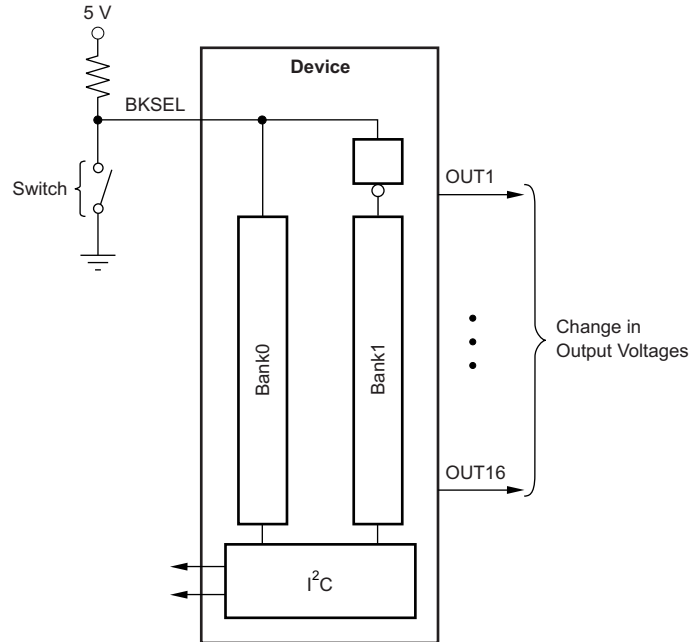

Figure 18. Gamma Control

7.4.2 Dynamic Gamma Control

Dynamic gamma control is a technique used to improve the picture quality in LCD television applications. This technique typically requires switching gamma curves between frames. Using the BKSEL pin to switch between two gamma curves does not often provide good results because of the 750 μ s required to transfer the data from the nonvolatile memory to the DAC register. However, dynamic gamma control can still be accomplished by storing two gamma curves in an external electrically erasable programmable read-only memory (EEPROM) and writing directly to the DAC register (volatile).

The double register input structure saves programming time by allowing updated DAC values to be pre-stored into the first register bank. Storage of this data can occur while a picture is still being displayed. Because the data are only stored into the first register bank, the DAC and VCOM output values remain unchanged—the display is unaffected. At the beginning or the end of a picture frame, the DAC and VCOM outputs (and therefore, the gamma voltages) can be quickly updated by writing a 1 in bit 15 of any DAC and VCOM register. For details on the operation of the double register input structure, see the [Updating the DAC Output Voltages](#) section.

To update all 18 programmable output voltages simultaneously via software, perform the following actions:

STEP 1: Write to registers 1–18 with bit 15 always 0.

STEP 2: Write any DAC and VCOM register a second time with identical data. Make sure that bit 15 is set to 1. All DAC and VCOM channels are updated simultaneously after receiving the last bit of data.

7.5 Programming

7.5.1 Addressing the Device

The device address 111010x, where x is the state of the A0 pin. When the A0 pin is low, the device acknowledges on address 74h (1110100). If the A0 pin is high, the device acknowledges on address 75h (1110101). [Table 2](#) shows the A0 pin settings and device address options.

Other valid addresses are possible through a simple mask change. Contact your TI representative for information.

Table 2. Quick-Reference of Device Addresses

DEVICE, COMPONENT (Device Address)	ADDRESS
A0 pin is low (device acknowledges on address 74h)	1110100
A0 pin is high (device acknowledges on address 75h)	1110101

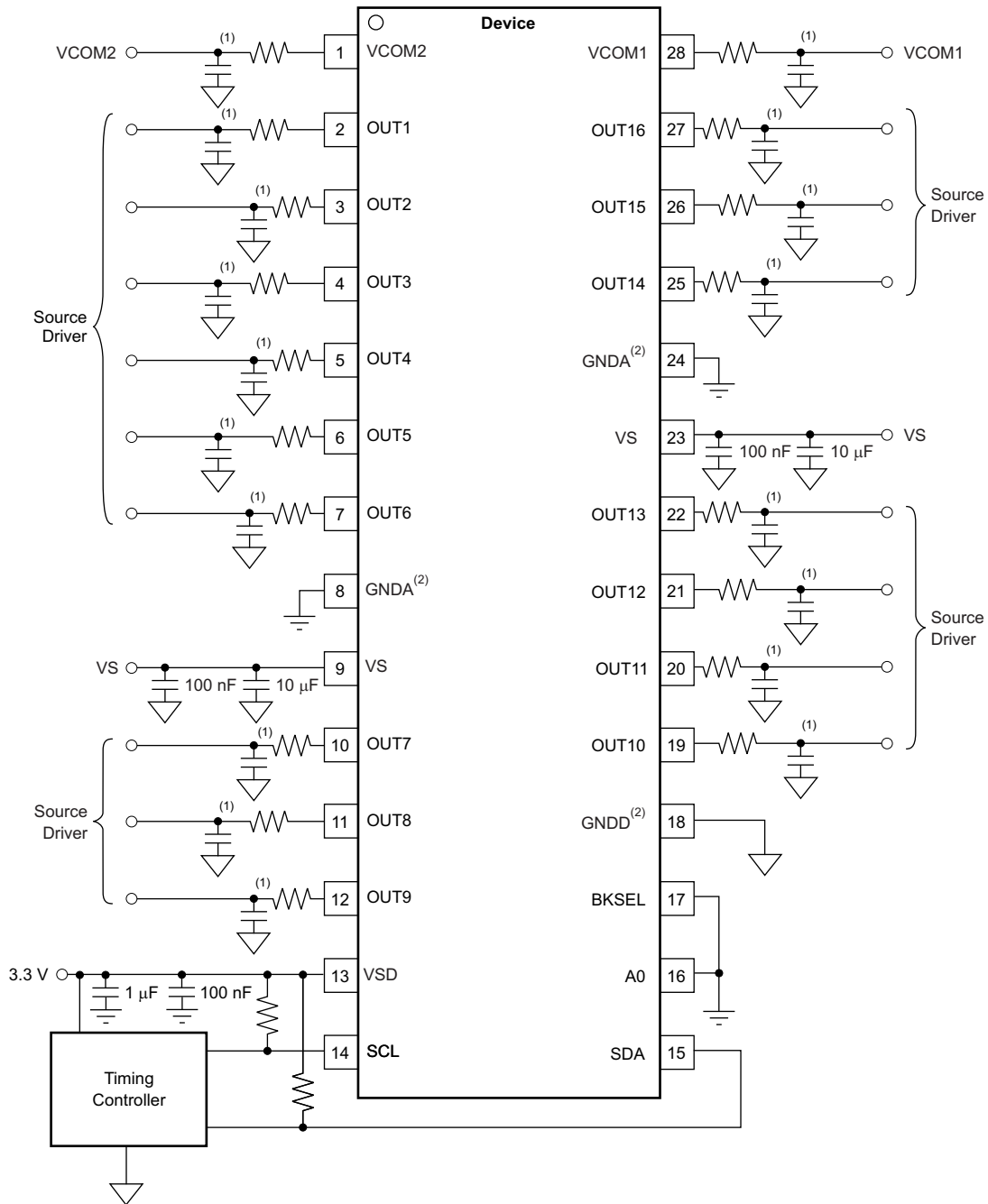

(1) RC combination optional; see the [Output Protection](#) section.

(2) GNDA and GNDD must be connected together.

Figure 19. Typical Application Configuration

7.5.2 Nonvolatile Memory

7.5.2.1 BKSEL Pin

The device has 16x rewrite capability of the nonvolatile memory. Additionally, the device is capable of storing two distinct gamma curves in two different nonvolatile memory banks, each of which has 16x rewrite capability. One of the two available banks is selected using the external input pin, BKSEL. When this pin is low, Bank0 is selected; when this pin is high, Bank1 is selected.

When the BKSEL pin changes state, the device acquires the last programmed DAC and VCOM values from the nonvolatile memory associated with this newly chosen bank. At power-up, the state of the BKSEL pin determines which memory bank is selected.

The I²C master can also update (acquire) the DAC registers with the last programmed nonvolatile memory values using software control. The bank to be acquired depends on the state of BKSEL.

7.5.2.2 General Acquire Command

A general acquire command is used to update all registers and DAC and VCOM outputs to the last programmed values stored in nonvolatile memory. A single-channel acquire command updates only the register and DAC and VCOM output of the DAC and VCOM corresponding to the DAC and VCOM address used in the single-channel acquire command.

These are the steps of the sequence to initiate a general channel acquire:

1. Be sure BKSEL is in its desired state and is stable for at least 1 ms.
2. Send a start condition on the bus.
3. Send the appropriate device address (based on A0) and the read or write bit = low. The device acknowledges this byte.
4. Send a DAC and VCOM pointer address byte. Set bit D7 = 1 and D6 = 0. Bits D5–D0 are any valid DAC and VCOM address. Although the device acknowledges 000000 through 010111, data are stored and returned only from these addresses:
 - 000000 through 001111
 - 010010 and 010011The device returns 0000 for reads from 010000 and 010001, and 010100 through 010111. See [Table 4](#) for valid DAC and VCOM addresses.
5. Send a stop condition on the bus.

Approximately 750 μ s (\pm 80 μ s) after issuing this command, all DAC and VCOM registers and DAC and VCOM output voltages change to the respective, appropriate nonvolatile memory values.

7.5.2.3 Single-Channel Acquire Command

These are the steps to initiate a single-channel acquire:

1. Be sure BKSEL is in its desired state and is stable for at least 1 ms.
2. Send a start condition on the bus.
3. Send the device address (based on A0) and read or write bit = low. The device acknowledges this byte.
4. Send a DAC and VCOM pointer address byte using the DAC and VCOM address corresponding to the output and register to update with the OTP memory value. Set bit D7 = 0 and D6 = 1. Bits D5–D0 are the DAC and VCOM address. Although the device acknowledges 000000 through 010111, data are stored and returned only from these addresses:
 - 000000 through 001111
 - 010010 and 010011The device returns 0000 reads from 010000 and 010001, and 010100 through 010111. See [Table 4](#) for valid DAC and VCOM addresses.
5. Send a stop condition on the bus.

Approximately 36 μ s (\pm 4 μ s) after issuing this command, the specified DAC and VCOM register and DAC and VCOM output voltage change to the appropriate OTP memory value.

7.5.2.4 MaxBank

The device can provide the user with the number of times the nonvolatile memory of a particular DAC and VCOM channel nonvolatile memory is written to for the current memory bank. This information is provided by reading the register at pointer address 111111.

There are two ways to update the MaxBank register:

1. After initiating a single acquire command, the device updates the MaxBank register with a code corresponding to how many times that particular channel memory is written to.
2. Following a general acquire command, the device updates the MaxBank register with a code corresponding to the maximum number of times the most used channel (OUT1–16 and VCOMs) is written to.

MaxBank is a read-only register and is only updated by performing a general- or single-channel acquire.

[Table 3](#) shows the relationship between the number of times the nonvolatile memory is programmed and the corresponding state of the MaxBank Register.

Table 3. MaxBank Details

NUMBER OF TIMES WRITTEN TO	RETURNS CODE
0	0000
1	0000
2	0001
3	0010
4	0011
5	0100
6	0101
7	0110
8	0111
9	1000
10	1001
11	1010
12	1011
13	1100
14	1101
15	1110
16	1111

7.5.2.5 Parity Error Correction

The device provides single-bit parity error correction for data stored in the nonvolatile memory to provide increased reliability of the nonvolatile memory. If a single bit of nonvolatile memory for a channel fails, the device corrects for the failure and updates the appropriate DAC with the intended value when its memory is acquired.

If more than one bit of nonvolatile memory for a channel fails, the device does not correct for it, and updates the appropriate DAC and VCOM with the default value of 100000000.

7.6 Register Maps

Table 4. DAC Register Pointer Addresses

DAC REGISTER	POINTER ADDRESS
OUT1	000000
OUT2	000001
OUT3	000010
OUT4	000011
OUT5	000100
OUT6	000101
OUT7	000110
OUT8	000111
OUT9	001000
OUT10	001001
OUT11	001010
OUT12	001011
OUT13	001100
OUT14	001101
OUT15	001110
OUT16	001111
VCOM1	010010
VCOM2	010011
OTHER REGISTER	POINTER ADDRESS
Die_Rev	111100
Die_ID	111101
MaxBank	111111

8 Application and Implementation

8.1 Application Information

The BUF16821-Q1 is a multichannel programmable voltage reference. Featuring 16 programmable gamma reference outputs and two programmable VCOM outputs, the device is designed to interface between timing controllers and source drivers commonly used in LCD displays.

8.2 Typical Application



Figure 20. Gamma Control Block Diagram

8.2.1 Design Requirements

If the nonvolatile memory has never been programmed, the BUF16821-Q1 outputs default to $V_S / 2$ following power-up. Refer to the [Power Supply Recommendations](#) section for proper power-supply sequencing requirements. [Figure 21](#) shows the typical output response when the analog power supply (V_S) ramps to its desired value. When the analog supply is below 2 V, the outputs follow the analog supply voltage. After the analog supply voltage (V_S) exceeds approximately 2 V, the outputs begin to track at $V_S / 2$. This sequence is illustrated in [Figure 21](#).

If the nonvolatile memory is pre-programmed, the device outputs ramp to their pre-programmed values. [Figure 22](#) and [Figure 23](#) illustrate the power-up behavior of the device pre-programmed to a 4-V and 8-V output voltage, respectively. Note that when the analog power supply voltage (V_S) exceeds approximately 5 V, the device performs an automatic read of the nonvolatile memory, acquiring the pre-programmed values to ensure the proper output value when the analog supply voltage ramps to its final value. During the nonvolatile memory acquire operation, the output tracks at $V_S / 2$ for approximately 1 ms. This sequence is illustrated in [Figure 22](#) and [Figure 23](#). Note that the minimum valid analog supply voltage, V_S , is specified as 9 V. Below this value the outputs should not be considered valid.

[Figure 24](#) illustrates the device output response to a general-call reset. During the internal reset, the output momentarily tracks at $V_S / 2$ while the nonvolatile memory values are acquired. Following the reset, the output returns to the pre-programmed value.

8.2.2 Detailed Design Procedure

Proper power-supply bypassing is required when using the BUF16821-Q1. TI recommends connecting a 10- μ F capacitor in parallel with a 100-nF capacitor at each analog supply pin (pins 9 and 23), as illustrated in [Figure 19](#). Similarly, connecting a 1- μ F capacitor in parallel with a 100-nF capacitor at the digital supply pin (pin 13) is also recommended. However, adding more than 200-pF capacitance at any gamma or VCOM output is not recommended; see the [Output Protection](#) section.

Typical Application (continued)

8.2.3 Application Curves

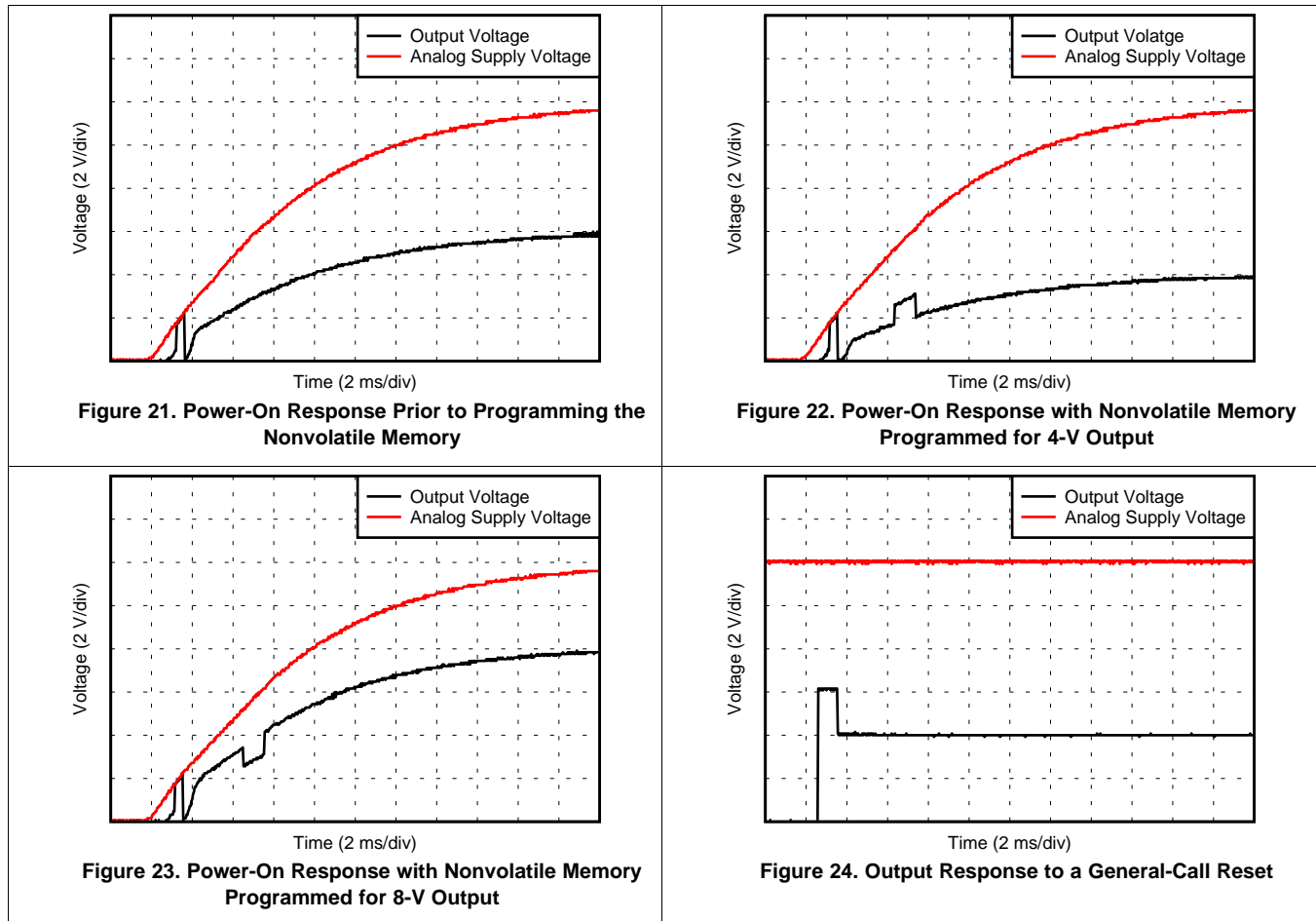

9 Power Supply Recommendations

The device can be powered using an analog supply voltage from 9 V to 20 V, and a digital supply from 2 V to 5.5 V. The digital supply must be applied before the analog supply to avoid excessive current and power consumption, or possibly even damage to the device if left connected only to the analog supply for extended periods of time.

10 Layout

10.1 Layout Guidelines

10.1.1 General PowerPAD Design Considerations

The device is available in a thermally-enhanced PowerPAD package. This package is constructed using a downset leadframe upon which the die is mounted; see [Figure 25\(a\)](#) and [Figure 25\(b\)](#). This arrangement results in the lead frame being exposed as a thermal pad on the underside of the package; see [Figure 25\(c\)](#). This thermal pad has direct thermal contact with the die; thus, excellent thermal performance is achieved by providing a good thermal path away from the thermal pad.

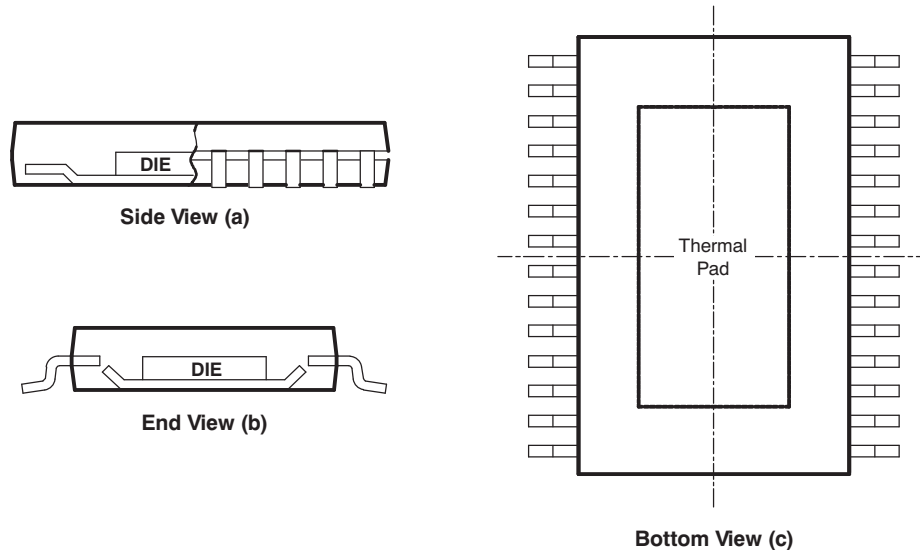

Figure 25. Views of a Thermally-Enhanced PWP Package

The PowerPAD package allows for both assembly and thermal management in one manufacturing operation. During the surface-mount solder operation (when the leads are being soldered), the thermal pad must be soldered to a copper area underneath the package. Through the use of thermal paths within this copper area, heat can be conducted away from the package into either a ground plane or other heat-dissipating device. Soldering the PowerPAD to the printed circuit board (PCB) is always required, even with applications that have low power dissipation. This technique provides the necessary thermal and mechanical connection between the lead frame die pad and the PCB.

The PowerPAD must be connected to the most negative supply voltage on the device, GNDA and GNDD.

1. Prepare the PCB with a top-side etch pattern. There should be etching for the leads as well as etch for the thermal pad.
2. Place recommended holes in the area of the thermal pad. Ideal thermal land size and thermal via patterns for the HTSSOP-28 PWP package can be seen in the technical brief, *PowerPAD Thermally-Enhanced Package (SLMA002)*, available for download at www.ti.com. These holes should be 13 mils (0.33 mm) in diameter. Keep these holes small, so that solder wicking through the holes is not a problem during reflow. An example thermal land pattern mechanical drawing is attached to the end of this data sheet.
3. Additional vias may be placed anywhere along the thermal plane outside of the thermal pad area to help dissipate the heat generated by the device. These additional vias may be larger than the 13-mil diameter vias directly under the thermal pad. These vias can be larger because they are not in the thermal pad area to be soldered; thus, wicking is not a problem.
4. Connect all holes to the internal plane that is at the same voltage potential as the GND pins.

Layout Guidelines (continued)

5. When connecting these holes to the internal plane, do not use the typical web or spoke via connection methodology. Web connections have a high thermal resistance connection that is useful for slowing the heat transfer during soldering operations. This configuration makes the soldering of vias that have plane connections easier. In this application, however, low thermal resistance is desired for the most efficient heat transfer. Therefore, the holes under the device PowerPAD package should make their connection to the internal plane with a complete connection around the entire circumference of the plated-through hole.
6. The top-side solder mask should leave the pins of the package and the thermal pad area with its twelve holes exposed. The bottom-side solder mask should cover the holes of the thermal pad area. This masking prevents solder from being pulled away from the thermal pad area during the reflow process.
7. Apply solder paste to the exposed thermal pad area and all device pins.
8. With these preparatory steps in place, simply place the device in position and run the chip through the solder reflow operation as any standard surface-mount component. This preparation results in a properly installed part.

For a given $R_{\theta JA}$ (listed in the [Electrical Characteristics](#)), the maximum power dissipation is shown in [Figure 26](#) and calculated by [Equation 2](#):

$$P_D = \left(\frac{T_{MAX} - T_A}{\theta_{JA}} \right)$$

where

- P_D = maximum power dissipation (W),
- T_{MAX} = absolute maximum junction temperature (125°C), and
- T_A = free-ambient air temperature (°C).

(2)

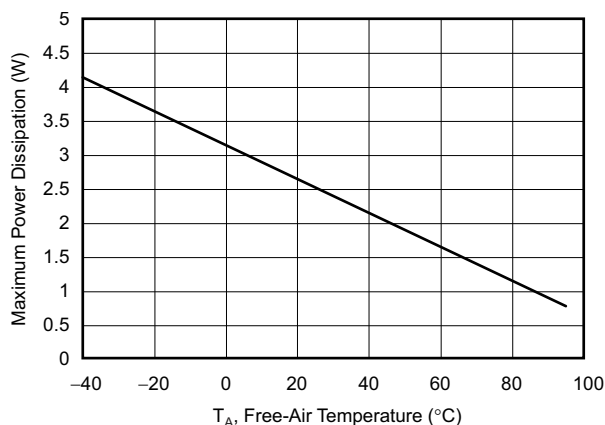
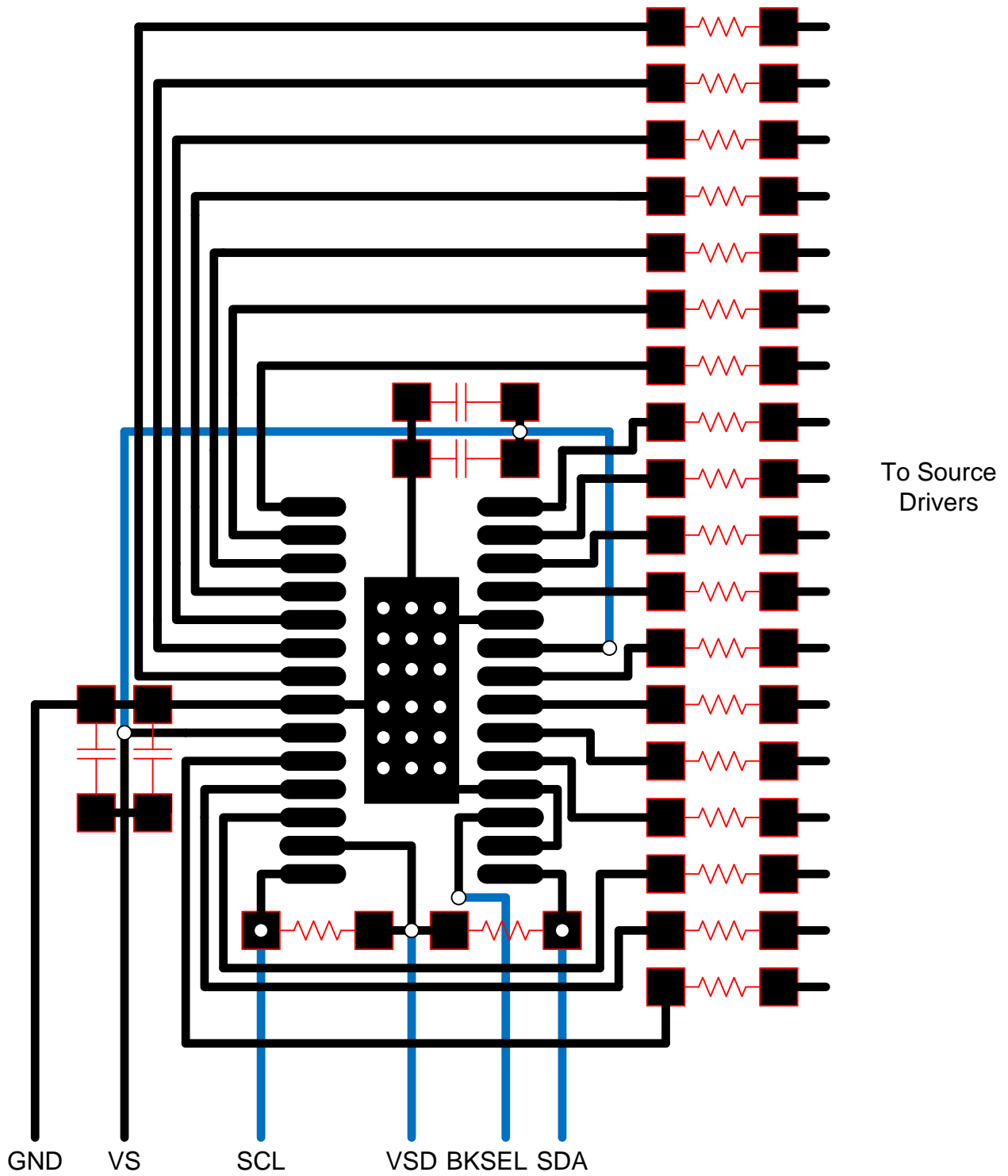

Figure 26. Maximum Power Dissipation vs Free-Air Temperature (With PowerPAD Soldered Down)

10.2 Layout Example



To Timing Controller

Figure 27. PCB Layout Example

11 器件和文档支持

11.1 文档支持

11.1.1 相关文档

相关文档如下：

- 《BUF16821EVM-USB 用户指南》， [SBOU106](#)
- 《BUF20820 数据表》， [SBOS330](#)
- 《PowerPAD 散热增强型封装》， [SLMA002](#)
- 《用伽马缓冲器驱动电容负载》， [SBOA134](#)

11.2 Trademarks

PowerPAD is a trademark of Texas Instruments.

I²C is a trademark of NXP Semiconductors.

All other trademarks are the property of their respective owners.

11.3 Electrostatic Discharge Caution



This integrated circuit can be damaged by ESD. Texas Instruments recommends that all integrated circuits be handled with appropriate precautions. Failure to observe proper handling and installation procedures can cause damage.

ESD damage can range from subtle performance degradation to complete device failure. Precision integrated circuits may be more susceptible to damage because very small parametric changes could cause the device not to meet its published specifications.

11.4 Glossary

[SLYZ022](#) — *TI Glossary*.

This glossary lists and explains terms, acronyms and definitions.

12 机械封装和可订购信息

以下页中包括机械封装和可订购信息。 这些信息是针对指定器件可提供的最新数据。 这些数据会在无通知且不对本文档进行修订的情况下发生改变。 欲获得该数据表的浏览器版本，请查阅左侧的导航栏。

重要声明

德州仪器(TI)及其下属子公司有权根据 JESD46 最新标准,对所提供的产品和服务进行更正、修改、增强、改进或其它更改,并有权根据 JESD48 最新标准中止提供任何产品和服务。客户在下订单前应获取最新的相关信息,并验证这些信息是否完整且是最新的。所有产品的销售都遵循在订单确认时所提供的TI 销售条款与条件。

TI 保证其所销售的组件的性能符合产品销售时 TI 半导体产品销售条件与条款的适用规范。仅在 TI 保证的范围内,且 TI 认为有必要时才会使用测试或其它质量控制技术。除非适用法律做出了硬性规定,否则没有必要对每种组件的所有参数进行测试。

TI 对应用帮助或客户产品设计不承担任何义务。客户应对其使用 TI 组件的产品和应用自行负责。为尽量减小与客户产品和应用相关的风险,客户应提供充分的设计与操作安全措施。

TI 不对任何 TI 专利权、版权、屏蔽作品权或其它与使用了 TI 组件或服务的组合设备、机器或流程相关的 TI 知识产权中授予的直接或隐含权限作出任何保证或解释。TI 所发布的与第三方产品或服务有关的信息,不能构成从 TI 获得使用这些产品或服务的许可、授权、或认可。使用此类信息可能需要获得第三方的专利权或其它知识产权方面的许可,或是 TI 的专利权或其它知识产权方面的许可。

对于 TI 的产品手册或数据表中 TI 信息的重要部分,仅在没有对内容进行任何篡改且带有相关授权、条件、限制和声明的情况下才允许进行复制。TI 对此类篡改过的文件不承担任何责任或义务。复制第三方的信息可能需要服从额外的限制条件。

在转售 TI 组件或服务时,如果对该组件或服务参数的陈述与 TI 标明的参数相比存在差异或虚假成分,则会失去相关 TI 组件或服务的所有明示或暗示授权,且这是不正当的、欺诈性商业行为。TI 对任何此类虚假陈述均不承担任何责任或义务。

客户认可并同意,尽管任何应用相关信息或支持仍可能由 TI 提供,但他们将独立负责满足与其产品及其在应用中使用的 TI 产品相关的所有法律、法规和安全相关要求。客户声明并同意,他们具备制定与实施安全措施所需的全部专业技术和知识,可预见故障的危险后果、监测故障及其后果、降低有可能造成人身伤害的故障的发生机率并采取适当的补救措施。客户将全额赔偿因在此类安全关键应用中使用任何 TI 组件而对 TI 及其代理造成的任何损失。

在某些场合中,为了推进安全相关应用有可能对 TI 组件进行特别的促销。TI 的目标是利用此类组件帮助客户设计和创立其特有的可满足适用的功能安全性标准和要求的终端产品解决方案。尽管如此,此类组件仍然服从这些条款。

TI 组件未获得用于 FDA Class III (或类似的生命攸关医疗设备)的授权许可,除非各方授权官员已经达成了专门管控此类使用的特别协议。

只有那些 TI 特别注明属于军用等级或“增强型塑料”的 TI 组件才是设计或专门用于军事/航空应用或环境的。购买者认可并同意,对并非指定面向军事或航空航天用途的 TI 组件进行军事或航空航天方面的应用,其风险由客户单独承担,并且由客户独立负责满足与此类使用相关的所有法律和法规要求。

TI 已明确指定符合 ISO/TS16949 要求的产品,这些产品主要用于汽车。在任何情况下,因使用非指定产品而无法达到 ISO/TS16949 要求, TI 不承担任何责任。

	产品		应用
数字音频	www.ti.com.cn/audio	通信与电信	www.ti.com.cn/telecom
放大器和线性器件	www.ti.com.cn/amplifiers	计算机及周边	www.ti.com.cn/computer
数据转换器	www.ti.com.cn/dataconverters	消费电子	www.ti.com.cn/consumer-apps
DLP® 产品	www.dlp.com	能源	www.ti.com.cn/energy
DSP - 数字信号处理器	www.ti.com.cn/dsp	工业应用	www.ti.com.cn/industrial
时钟和计时器	www.ti.com.cn/clockandtimers	医疗电子	www.ti.com.cn/medical
接口	www.ti.com.cn/interface	安防应用	www.ti.com.cn/security
逻辑	www.ti.com.cn/logic	汽车电子	www.ti.com.cn/automotive
电源管理	www.ti.com.cn/power	视频和影像	www.ti.com.cn/video
微控制器 (MCU)	www.ti.com.cn/microcontrollers		
RFID 系统	www.ti.com.cn/rfidsys		
OMAP应用处理器	www.ti.com/omap		
无线连通性	www.ti.com.cn/wirelessconnectivity	德州仪器在线技术支持社区	www.deyisupport.com

邮寄地址: 上海市浦东新区世纪大道1568号, 中建大厦32楼邮政编码: 200122
Copyright © 2014, 德州仪器半导体技术(上海)有限公司

PACKAGING INFORMATION

Orderable Device	Status (1)	Package Type	Package Drawing	Pins	Package Qty	Eco Plan (2)	Lead finish/ Ball material (6)	MSL Peak Temp (3)	Op Temp (°C)	Device Marking (4/5)	Samples
BUF16821AIPWPRQ1	ACTIVE	HTSSOP	PWP	28	2000	RoHS & Green	NIPDAU	Level-2-260C-1 YEAR	-40 to 85	B16821Q1	Samples

(1) The marketing status values are defined as follows:

ACTIVE: Product device recommended for new designs.

LIFEBUY: TI has announced that the device will be discontinued, and a lifetime-buy period is in effect.

NRND: Not recommended for new designs. Device is in production to support existing customers, but TI does not recommend using this part in a new design.

PREVIEW: Device has been announced but is not in production. Samples may or may not be available.

OBSOLETE: TI has discontinued the production of the device.

(2) **RoHS:** TI defines "RoHS" to mean semiconductor products that are compliant with the current EU RoHS requirements for all 10 RoHS substances, including the requirement that RoHS substance do not exceed 0.1% by weight in homogeneous materials. Where designed to be soldered at high temperatures, "RoHS" products are suitable for use in specified lead-free processes. TI may reference these types of products as "Pb-Free".

RoHS Exempt: TI defines "RoHS Exempt" to mean products that contain lead but are compliant with EU RoHS pursuant to a specific EU RoHS exemption.

Green: TI defines "Green" to mean the content of Chlorine (Cl) and Bromine (Br) based flame retardants meet JS709B low halogen requirements of <=1000ppm threshold. Antimony trioxide based flame retardants must also meet the <=1000ppm threshold requirement.

(3) MSL, Peak Temp. - The Moisture Sensitivity Level rating according to the JEDEC industry standard classifications, and peak solder temperature.

(4) There may be additional marking, which relates to the logo, the lot trace code information, or the environmental category on the device.

(5) Multiple Device Markings will be inside parentheses. Only one Device Marking contained in parentheses and separated by a "-" will appear on a device. If a line is indented then it is a continuation of the previous line and the two combined represent the entire Device Marking for that device.

(6) Lead finish/Ball material - Orderable Devices may have multiple material finish options. Finish options are separated by a vertical ruled line. Lead finish/Ball material values may wrap to two lines if the finish value exceeds the maximum column width.

Important Information and Disclaimer:The information provided on this page represents TI's knowledge and belief as of the date that it is provided. TI bases its knowledge and belief on information provided by third parties, and makes no representation or warranty as to the accuracy of such information. Efforts are underway to better integrate information from third parties. TI has taken and continues to take reasonable steps to provide representative and accurate information but may not have conducted destructive testing or chemical analysis on incoming materials and chemicals. TI and TI suppliers consider certain information to be proprietary, and thus CAS numbers and other limited information may not be available for release.

In no event shall TI's liability arising out of such information exceed the total purchase price of the TI part(s) at issue in this document sold by TI to Customer on an annual basis.

GENERIC PACKAGE VIEW

PWP 28

PowerPAD™ TSSOP - 1.2 mm max height

4.4 x 9.7, 0.65 mm pitch

SMALL OUTLINE PACKAGE

This image is a representation of the package family, actual package may vary.
Refer to the product data sheet for package details.

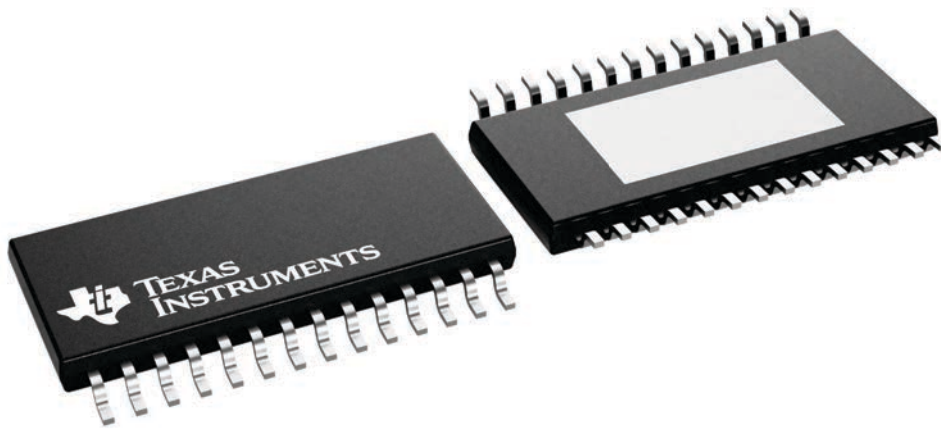

4224765/B

MECHANICAL DATA

PWP (R-PDSO-G28)

PowerPAD™ PLASTIC SMALL OUTLINE

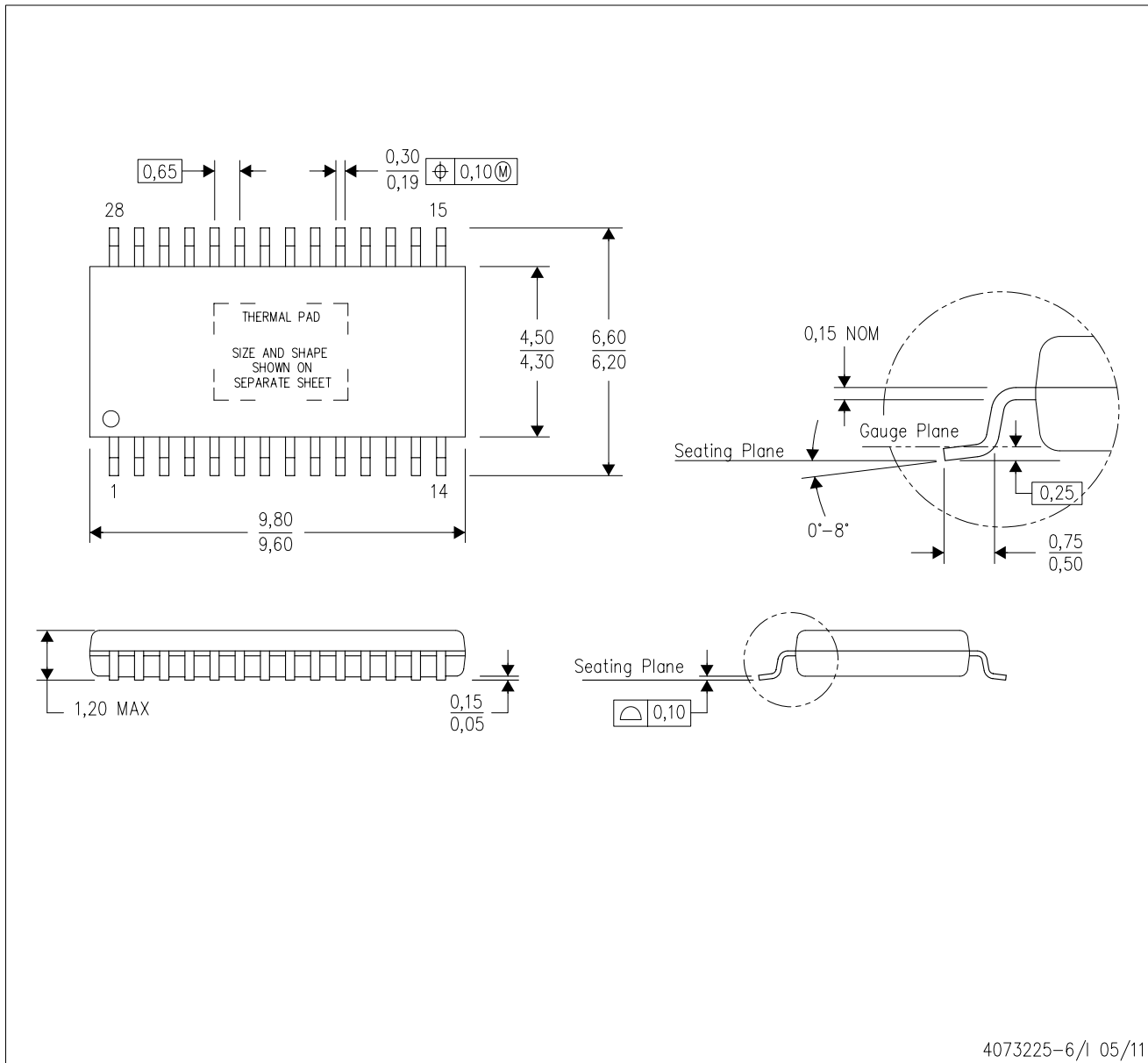

- NOTES:
- All linear dimensions are in millimeters.
 - This drawing is subject to change without notice.
 - Body dimensions do not include mold flash or protrusions. Mold flash and protrusion shall not exceed 0.15 per side.
 - This package is designed to be soldered to a thermal pad on the board. Refer to Technical Brief, PowerPad Thermally Enhanced Package, Texas Instruments Literature No. SLMA002 for information regarding recommended board layout. This document is available at www.ti.com <<http://www.ti.com>>.
 - See the additional figure in the Product Data Sheet for details regarding the exposed thermal pad features and dimensions.
 - Falls within JEDEC MO-153

PowerPAD is a trademark of Texas Instruments.

THERMAL PAD MECHANICAL DATA

PWP (R-PDSO-G28) PowerPAD™ SMALL PLASTIC OUTLINE

THERMAL INFORMATION

This PowerPAD™ package incorporates an exposed thermal pad that is designed to be attached to a printed circuit board (PCB). The thermal pad must be soldered directly to the PCB. After soldering, the PCB can be used as a heatsink. In addition, through the use of thermal vias, the thermal pad can be attached directly to the appropriate copper plane shown in the electrical schematic for the device, or alternatively, can be attached to a special heatsink structure designed into the PCB. This design optimizes the heat transfer from the integrated circuit (IC).

For additional information on the PowerPAD package and how to take advantage of its heat dissipating abilities, refer to Technical Brief, PowerPAD Thermally Enhanced Package, Texas Instruments Literature No. SLMA002 and Application Brief, PowerPAD Made Easy, Texas Instruments Literature No. SLMA004. Both documents are available at www.ti.com.

The exposed thermal pad dimensions for this package are shown in the following illustration.

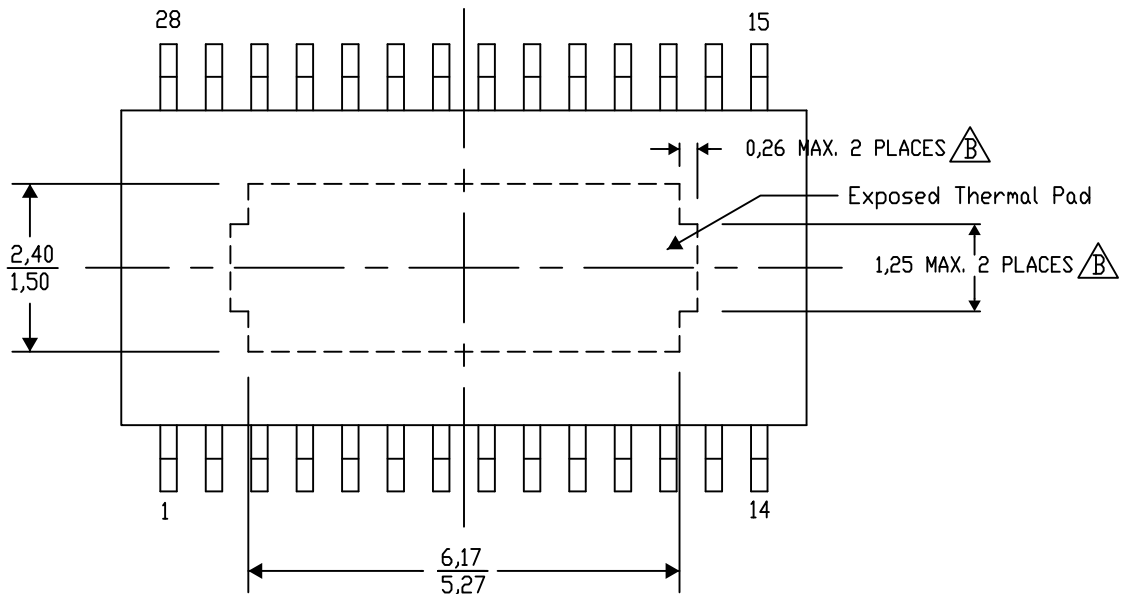

Top View

Exposed Thermal Pad Dimensions

4206332-33/AO 01/16

NOTE: A. All linear dimensions are in millimeters

$\triangle B$. Exposed tie strap features may not be present.

PowerPAD is a trademark of Texas Instruments

PWP (R-PDSO-G28)

PowerPAD™ PLASTIC SMALL OUTLINE

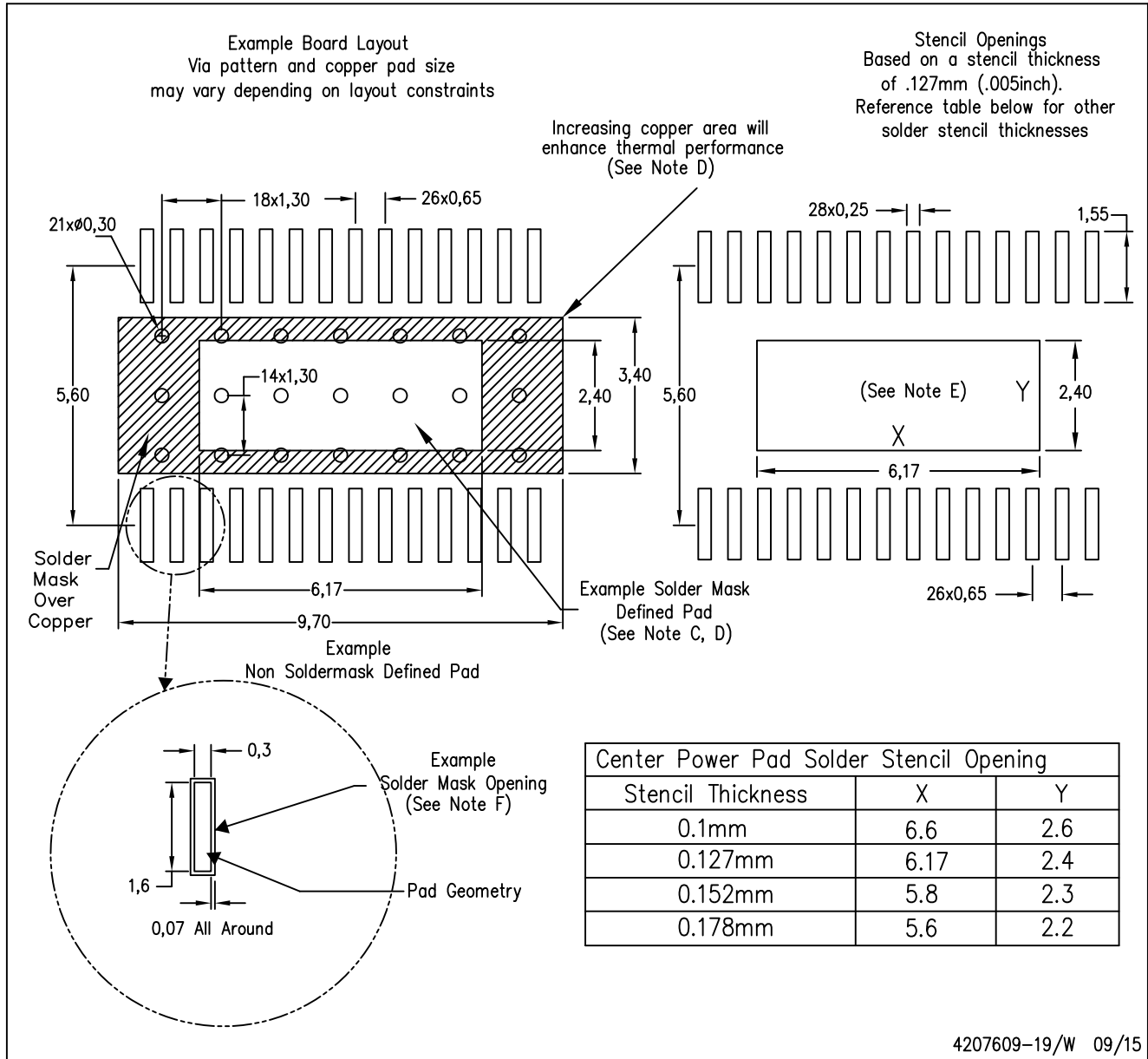

NOTES:

- A. All linear dimensions are in millimeters.
- B. This drawing is subject to change without notice.
- C. Customers should place a note on the circuit board fabrication drawing not to alter the center solder mask defined pad.
- D. This package is designed to be soldered to a thermal pad on the board. Refer to Technical Brief, PowerPad Thermally Enhanced Package, Texas Instruments Literature No. SLMA002, SLMA004, and also the Product Data Sheets.
- E. For specific thermal information, via requirements, and recommended board layout. These documents are available at www.ti.com <<http://www.ti.com>>. Publication IPC-7351 is recommended for alternate designs. Laser cutting apertures with trapezoidal walls and also rounding corners will offer better paste release. Customers should contact their board assembly site for stencil design recommendations. Example stencil design based on a 50% volumetric metal load solder paste. Refer to IPC-7525 for other stencil
- F. Customers should contact their board fabrication site for solder mask tolerances between and around signal pads.

重要声明和免责声明

TI 均以“原样”提供技术性 & 可靠性数据（包括数据表）、设计资源（包括参考设计）、应用或其他设计建议、网络工具、安全信息和其他资源，不保证其中不含任何瑕疵，且不做任何明示或暗示的担保，包括但不限于对适销性、适合某特定用途或不侵犯任何第三方知识产权的暗示担保。

所述资源可供专业开发人员应用 TI 产品进行设计使用。您将对以下行为独自承担全部责任：(1) 针对您的应用选择合适的 TI 产品；(2) 设计、验证并测试您的应用；(3) 确保您的应用满足相应标准以及任何其他安全、安保或其他要求。所述资源如有变更，恕不另行通知。TI 对您使用所述资源的授权仅限于开发资源所涉及 TI 产品的相关应用。除此之外不得复制或展示所述资源，也不提供其它 TI 或任何第三方的知识产权授权许可。如因使用所述资源而产生任何索赔、赔偿、成本、损失及债务等，TI 对此概不负责，并且您须赔偿由此对 TI 及其代表造成的损害。

TI 所提供产品均受 TI 的销售条款 (<http://www.ti.com.cn/zh-cn/legal/termsofsale.html>) 以及 [ti.com.cn](http://www.ti.com.cn) 上或随附 TI 产品提供的其他可适用条款的约束。TI 提供所述资源并不扩展或以其他方式更改 TI 针对 TI 产品所发布的可适用的担保范围或担保免责声明。

邮寄地址：上海市浦东新区世纪大道 1568 号中建大厦 32 楼，邮政编码：200122

Copyright © 2020 德州仪器半导体技术（上海）有限公司