

# ISO774x High-Speed, Robust-EMC Reinforced and Basic Quad-Channel Digital Isolators

## 1 Features

- 100 Mbps data rate
- Robust isolation barrier:
  - >100-year projected lifetime at 1500 V<sub>RMS</sub> working voltage
  - Up to 5000 V<sub>RMS</sub> isolation rating
  - Up to 12.8 kV surge capability
  - ±100 kV/μs typical CMTI
- Wide supply range: 2.25 V to 5.5 V
- 2.25-V to 5.5-V level translation
- Default output *high* (ISO774x) and *low* (ISO774xF) options
- Wide temperature range: –55°C to 125°C
- Low power consumption, typical 1.5 mA per channel at 1 Mbps
- Low propagation delay: 10.7 ns typical (5-V Supplies)
- Robust electromagnetic compatibility (EMC)
  - System-level ESD, EFT, and surge immunity
  - ±8 kV IEC 61000-4-2 contact discharge protection across isolation barrier
  - Low emissions
- Wide-SOIC (DW-16) and QSOP (DBQ-16) package options
- Automotive version available: [ISO774x-Q1](#)
- Safety-related certifications:
  - DIN VDE V 0884-11:2017-01
  - UL 1577 component recognition program
  - CSA, CQC, and TUV certifications

## 2 Applications

- [Industrial automation](#)
- [Motor control](#)
- [Power supplies](#)
- [Solar inverters](#)
- [Medical equipment](#)

## 3 Description

The ISO774x devices are high-performance, quad-channel digital isolators with 5000 V<sub>RMS</sub> (DW package) and 3000 V<sub>RMS</sub> (DBQ package) isolation ratings per UL 1577. This family includes devices with reinforced insulation ratings according to VDE, CSA, TUV and CQC. The ISO7741B device is designed for applications that require basic insulation ratings only.

The ISO774x devices provide high electromagnetic immunity and low emissions at low power consumption, while isolating CMOS or LVCMOS digital I/Os. Each isolation channel has a logic input and output buffer separated by a double capacitive silicon dioxide (SiO<sub>2</sub>) insulation barrier. These devices come with enable pins which can be used to put the respective outputs in high impedance for multi-master driving applications and to reduce power consumption. The ISO7740 device has all four channels in the same direction, the ISO7741 device has three forward and one reverse-direction channels, and the ISO7742 device has two forward and two reverse-direction channels. If the input power or signal is lost, default output is *high* for devices without suffix F and *low* for devices with suffix F. See the [Device Functional Modes](#) section for further details.

### Device Information<sup>(1)</sup>

PART NUMBER	PACKAGE	BODY SIZE (NOM)
ISO7740	SOIC (DW)	10.30 mm x 7.50 mm
ISO7741	SSOP (DBQ)	4.90 mm x 3.90 mm
ISO7742		
ISO7741B	SOIC (DW)	10.30 mm x 7.50 mm

(1) For all available packages, see the orderable addendum at the end of the data sheet.

### Simplified Schematic

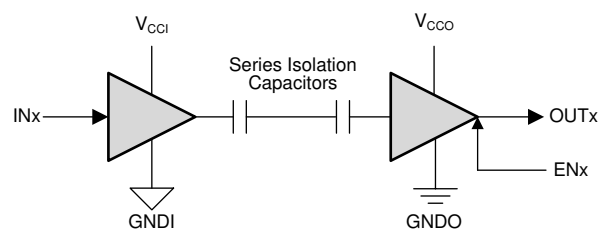

V<sub>CCI</sub>=Input supply, V<sub>CCO</sub>=Output supply  
 GNDI=Input ground, GNDO=Output ground



## Table of Contents

<b>1 Features</b> .....	1	7.18 Insulation Characteristics Curves .....	20
<b>2 Applications</b> .....	1	7.19 Typical Characteristics .....	21
<b>3 Description</b> .....	1	<b>8 Parameter Measurement Information</b> .....	23
<b>4 Revision History</b> .....	2	<b>9 Detailed Description</b> .....	25
<b>5 Description Continued</b> .....	5	9.1 Overview .....	25
<b>6 Pin Configuration and Functions</b> .....	6	9.2 Functional Block Diagram .....	25
<b>7 Specifications</b> .....	8	9.3 Feature Description .....	26
7.1 Absolute Maximum Ratings .....	8	9.4 Device Functional Modes .....	27
7.2 ESD Ratings .....	8	<b>10 Application and Implementation</b> .....	29
7.3 Recommended Operating Conditions .....	8	10.1 Application Information .....	29
7.4 Thermal Information .....	9	10.2 Typical Application .....	29
7.5 Power Rating .....	9	<b>11 Power Supply Recommendations</b> .....	32
7.6 Insulation Specifications .....	10	<b>12 Layout</b> .....	33
7.7 Safety-Related Certifications .....	11	12.1 Layout Guidelines .....	33
7.8 Safety Limiting Values .....	11	12.2 Layout Example .....	33
7.9 Electrical Characteristics—5-V Supply .....	12	<b>13 Device and Documentation Support</b> .....	34
7.10 Supply Current Characteristics—5-V Supply .....	13	13.1 Documentation Support .....	34
7.11 Electrical Characteristics—3.3-V Supply .....	14	13.2 Related Links .....	34
7.12 Supply Current Characteristics—3.3-V Supply .....	15	13.3 Receiving Notification of Documentation Updates .....	34
7.13 Electrical Characteristics—2.5-V Supply .....	16	13.4 Community Resources .....	34
7.14 Supply Current Characteristics—2.5-V Supply .....	17	13.5 Trademarks .....	34
7.15 Switching Characteristics—5-V Supply .....	18	13.6 Electrostatic Discharge Caution .....	34
7.16 Switching Characteristics—3.3-V Supply .....	18	13.7 Glossary .....	35
7.17 Switching Characteristics—2.5-V Supply .....	19	<b>14 Mechanical, Packaging, and Orderable Information</b> .....	35

## 4 Revision History

NOTE: Page numbers for previous revisions may differ from page numbers in the current version.

Changes from Revision F (May 2019) to Revision G	Page
• Added ISO7741B device to the data sheet for applications that require basic insulation only .....	1
• Combined CSA, CQC, and TUV <a href="#">Features</a> bullets into a single bullet .....	1
• Deleted "All certifications complete" bullet in <a href="#">Features</a> .....	1

Changes from Revision E (January 2018) to Revision F	Page
• Made editorial and cosmetic changes throughout the document .....	1
• Changed From: "Isolation Barrier Life: >40 Years" To: ">100-year projected lifetime at 1500 V <sub>RMS</sub> working voltage" in <a href="#">Features</a> .....	1
• Added "Up to 5000 V <sub>RMS</sub> isolation rating" in <a href="#">Features</a> .....	1
• Added "Up to 12.8 kV surge capability" in <a href="#">Features</a> .....	1
• Added "±8 kV IEC 61000-4-2 contact discharge protection across isolation barrier" in <a href="#">Features</a> .....	1
• Added "Automotive version available: <i>ISO774x-Q1</i> " in <a href="#">Features</a> .....	1
• Changed From: "All Certifications Complete except CQC Approval of DBQ-16 Package Devices" To: "All certifications complete" in <a href="#">Features</a> .....	1
• Updated <a href="#">Simplified Schematic</a> to show two isolation capacitors in series per channel instead of a single isolation capacitor .....	1
• Added "Contact discharge per IEC 61000-4-2" specification of ±8000 V in <a href="#">ESD Ratings</a> .....	8
• Added the following table note to <i>Data rate</i> specification: "100 Mbps is the maximum specified data rate, although higher data rates are possible." .....	8

• Changed $V_{IORM}$ value for DW-16 package From: "1414 $V_{PK}$ " To: "2121 $V_{PK}$ " in <a href="#">Insulation Specifications</a> table.....	10
• Changed $V_{IOWM}$ values for DW-16 package From: "1000 $V_{RMS}$ " and "1414 $V_{DC}$ " To: "1500 $V_{RMS}$ " and "2121 $V_{DC}$ " in <a href="#">Insulation Specifications</a> table .....	10
• Added 'see <a href="#">Figure 28</a> ' to TEST CONDITIONS of $V_{IOWM}$ specification in <a href="#">Insulation Specifications</a> .....	10
• Changed $V_{IOSM}$ TEST CONDITIONS From: "Test method per IEC 60065" To: "Test method per IEC 62368-1" in <a href="#">Insulation Specifications</a> table .....	10
• Updated certification information in <a href="#">Safety-Related Certifications</a> table .....	11
• Switched the line colors for $V_{CC}$ at 2.5 V and $V_{CC}$ at 3.3 V in <a href="#">Figure 12</a> .....	21
• Added <a href="#">Insulation Lifetime</a> sub-section under <a href="#">Application Curve</a> section.....	31
• Added 'How to use isolation to improve ESD, EFT, and Surge immunity in industrial systems' application report to <a href="#">Documentation Support</a> section .....	34

**Changes from Revision D (May 2017) to Revision E**
**Page**

• Changed the DIN certification number and certification status throughout the document.....	1
• Changed the isolation rating of the DBQ package from 2500 $V_{RMS}$ to 3000 $V_{RMS}$ .....	1
• Added $V_{TEST}$ to the conditions for the maximum transient isolation voltage parameter in the <a href="#">Insulation Specifications</a> table.....	10
• Changed the value for the DBQ package from 3600 $V_{PK}$ to 4242 $V_{PK}$ throughout the document.....	10
• Changed the method b1 $V_{ini}$ condition for apparent charge in the <a href="#">Insulation Specifications</a> table .....	10
• Switched the labels for $V_{CC1}$ falling and $V_{CC2}$ rising in the graph legend of <a href="#">Power Supply Undervoltage Threshold vs Free-Air Temperature</a> .....	21

**Changes from Revision C (December 2016) to Revision D**
**Page**

• Updated the <a href="#">Safety-Related Certifications</a> table.....	11
• Changed the minimum CMTI from 40 to 85 in all <a href="#">Electrical Characteristics</a> tables .....	12

**Changes from Revision B (October 2016) to Revision C**
**Page**

• Changed the <a href="#">Regulatory Information</a> table to <a href="#">Safety-Related Certifications</a> and updated content.....	11
• Changed the certifications from planned to certified in the <a href="#">Safety-Related Certifications</a> table.....	11

**Changes from Revision A (June 2016) to Revision B**
**Page**

• Changed <a href="#">Feature</a> From: High CMTI: $\pm 75$ $kV/\mu s$ Typical To: High CMTI: $\pm 100$ $kV/\mu s$ Typical .....	1
• Changed <a href="#">Feature</a> From: All Certifications are Planned To: 'VDE, UL, and TUV Certifications for DW Package Complete; All Other Certifications are Planned'.....	1
• Changed the unit value of CLR and CPG From: $\mu m$ To: mm in <a href="#">Insulation Specifications</a> .....	10
• Changed From: "Plan to certify" To: "Certified" in column VDE of <a href="#">Safety-Related Certifications</a> .....	11
• Added a conditions statement to <a href="#">Safety-Related Certifications</a> .....	11
• Changed From: "Plan to certify" To: "Certified" in column UL of <a href="#">Safety-Related Certifications</a> .....	11
• Changed From: "Plan to certify" To: "Certified" in column TUV of <a href="#">Safety-Related Certifications</a> .....	11
• Changed From: "Certification Planned" To: 'Certificate number: 40040142' in column VDE of <a href="#">Safety-Related Certifications</a> .....	11
• Changed From: "Certification Planned" To: "File number: E181974" in column VDE of <a href="#">Safety-Related Certifications</a> .....	11
• Changed From: "Certification Planned" To: "Client ID number: 77311" in column TUV of <a href="#">Safety-Related Certifications</a> ...	11
• Changed the CMTI TYP value From: 75 $kV/\mu s$ To: 100 $kV/\mu s$ in the <a href="#">Electrical Characteristics—5-V Supply</a> .....	12
• Changed the CMTI TYP value From: 75 $kV/\mu s$ To: 100 $kV/\mu s$ in the <a href="#">Electrical Characteristics—3.3-V Supply</a> .....	14
• Changed the CMTI TYP value From: 75 $kV/\mu s$ To: 100 $kV/\mu s$ in the <a href="#">Electrical Characteristics—2.5-V Supply</a> .....	16

• Changed the $t_{DO}$ TYP value From: 6 $\mu$ s To: 0.1 $\mu$ s and the MAX value From: 9 $\mu$ s To: 0.3 $\mu$ s in the <a href="#">Switching Characteristics—5-V Supply</a> .....	18
• Changed the $t_{DO}$ TYP value From: 6 $\mu$ s To: 0.1 $\mu$ s and the MAX value From: 9 $\mu$ s To: 0.3 $\mu$ s in the <a href="#">Switching Characteristics—3.3-V Supply</a> .....	18
• Changed the $t_{DO}$ TYP value From: 6 $\mu$ s To: 0.1 $\mu$ s and the MAX value From: 9 $\mu$ s To: 0.3 $\mu$ s in the <a href="#">Switching Characteristics—2.5-V Supply</a> .....	19
• Added Note B to <a href="#">Figure 17</a> .....	24
• Changed the <a href="#">Design Requirements</a> paragraph .....	30
• Replaced the <a href="#">Power Supply Recommendations</a> section .....	32

---

**Changes from Original (March 2016) to Revision A**
**Page**

• Changed the device status From: Preview To: Production. ....	1
--	---

---

## 5 Description Continued

Used in conjunction with isolated power supplies, these devices help prevent noise currents on data buses, such as RS-485, RS-232, and CAN, or other circuits from entering the local ground and interfering with or damaging sensitive circuitry. Through innovative chip design and layout techniques, electromagnetic compatibility of the ISO774x devices have been significantly enhanced to ease system-level ESD, EFT, surge, and emissions compliance. The ISO774x devices are available in 16-pin SOIC and QSOP packages.

## 6 Pin Configuration and Functions

**ISO7740 DW and DBQ Packages**  
16-Pin SOIC-WB and QSOP  
Top View

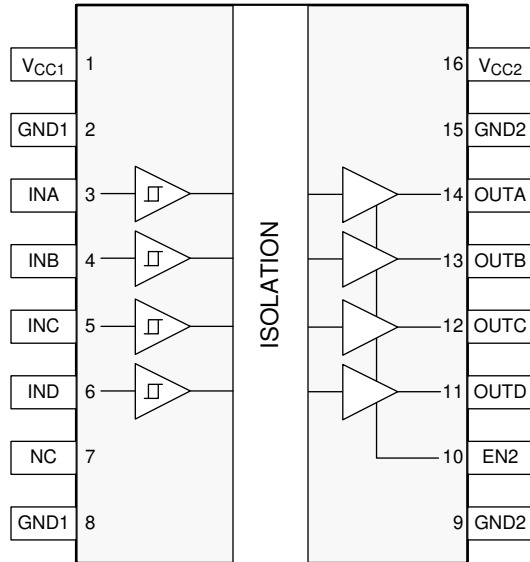

**ISO7741 DW and DBQ Packages**  
16-Pin SOIC-WB and QSOP  
Top View

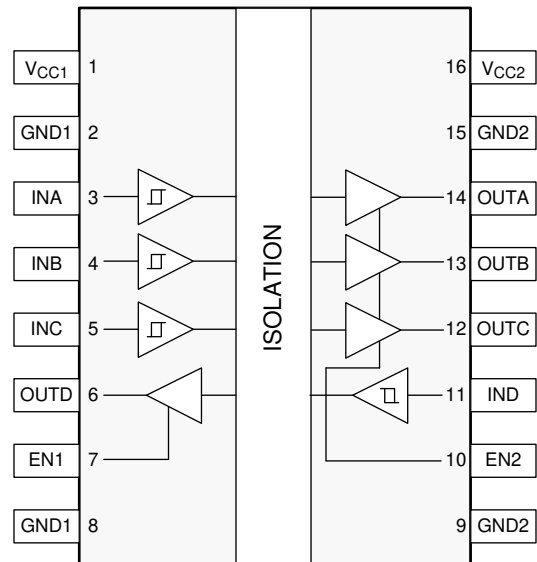

**ISO7742 DW and DBQ Packages**  
16-Pin SOIC-WB and QSOP  
Top View

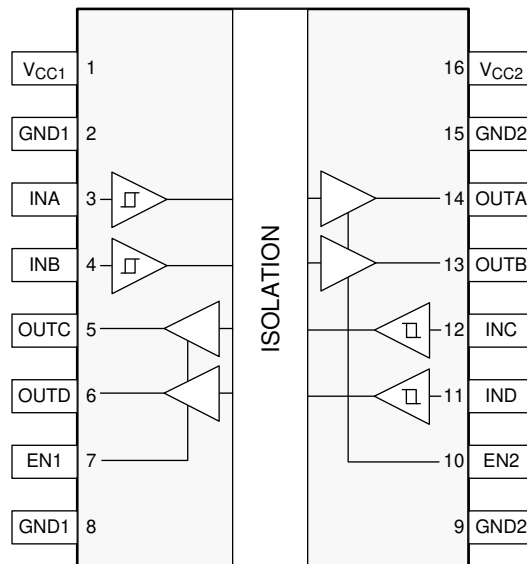

**Pin Functions**

NAME	PIN			I/O	DESCRIPTION
	ISO7740	ISO7741	ISO7742		
EN1	—	7	7	I	Output enable 1. Output pins on side 1 are enabled when EN1 is high or open and in high-impedance state when EN1 is low.
EN2	10	10	10	I	Output enable 2. Output pins on side 2 are enabled when EN2 is high or open and in high-impedance state when EN2 is low.
GND1	2	2	2	—	Ground connection for $V_{CC1}$
	8	8	8		
GND2	9	9	9	—	Ground connection for $V_{CC2}$
	15	15	15		
INA	3	3	3	I	Input, channel A
INB	4	4	4	I	Input, channel B
INC	5	5	12	I	Input, channel C
IND	6	11	11	I	Input, channel D
NC	7	—	—	—	Not connected
OUTA	14	14	14	O	Output, channel A
OUTB	13	13	13	O	Output, channel B
OUTC	12	12	5	O	Output, channel C
OUTD	11	6	6	O	Output, channel D
$V_{CC1}$	1	1	1	—	Power supply, side 1
$V_{CC2}$	16	16	16	—	Power supply, side 2

## 7 Specifications

### 7.1 Absolute Maximum Ratings

 See <sup>(1)</sup>

		MIN	MAX	UNIT
$V_{CC1}, V_{CC2}$	Supply voltage <sup>(2)</sup>	-0.5	6	V
V	Voltage at INx, OUTx, ENx	-0.5	$V_{CCX} + 0.5^{(3)}$	V
$I_O$	Output current	-15	15	mA
$T_J$	Junction temperature		150	°C
$T_{stg}$	Storage temperature	-65	150	°C

- (1) Stresses beyond those listed under *Absolute Maximum Ratings* may cause permanent damage to the device. These are stress ratings only and functional operation of the device at these or any other conditions beyond those indicated under *Recommended Operating Conditions* is not implied. Exposure to absolute-maximum-rated conditions for extended periods may affect device reliability.
- (2) All voltage values except differential I/O bus voltages are with respect to the local ground terminal (GND1 or GND2) and are peak voltage values.
- (3) Maximum voltage must not exceed 6 V.

### 7.2 ESD Ratings

		VALUE	UNIT
$V_{(ESD)}$	Electrostatic discharge	Human body model (HBM), per ANSI/ESDA/JEDEC JS-001, all pins <sup>(1)</sup>	±6000
		Charged device model (CDM), per JEDEC specification JESD22-C101, all pins <sup>(2)</sup>	±1500
		Contact discharge per IEC 61000-4-2; Isolation barrier withstand test <sup>(3)(4)</sup>	±8000

- (1) JEDEC document JEP155 states that 500-V HBM allows safe manufacturing with a standard ESD control process.
- (2) JEDEC document JEP157 states that 250-V CDM allows safe manufacturing with a standard ESD control process.
- (3) IEC ESD strike is applied across the barrier with all pins on each side tied together creating a two-terminal device.
- (4) Testing is carried out in air or oil to determine the intrinsic contact discharge capability of the device.

### 7.3 Recommended Operating Conditions

		MIN	NOM	MAX	UNIT
$V_{CC1}, V_{CC2}$	Supply voltage	2.25		5.5	V
$V_{CC(UVLO+)}$	UVLO threshold when supply voltage is rising		2	2.25	V
$V_{CC(UVLO-)}$	UVLO threshold when supply voltage is falling	1.7	1.8		V
$V_{HYS(UVLO)}$	Supply voltage UVLO hysteresis	100	200		mV
$I_{OH}$	High-level output current	$V_{CCO}^{(1)} = 5\text{ V}$		-4	mA
		$V_{CCO} = 3.3\text{ V}$		-2	
		$V_{CCO} = 2.5\text{ V}$		-1	
$I_{OL}$	Low-level output current	$V_{CCO} = 5\text{ V}$		4	mA
		$V_{CCO} = 3.3\text{ V}$		2	
		$V_{CCO} = 2.5\text{ V}$		1	
$V_{IH}$	High-level input voltage	$0.7 \times V_{CCI}^{(1)}$		$V_{CCI}$	V
$V_{IL}$	Low-level input voltage	0		$0.3 \times V_{CCI}$	V
DR	Data rate <sup>(2)</sup>	0		100	Mbps
$T_A$	Ambient temperature	-55	25	125	°C

- (1)  $V_{CCI}$  = Input-side  $V_{CC}$ ;  $V_{CCO}$  = Output-side  $V_{CC}$ .
- (2) 100 Mbps is the maximum specified data rate, although higher data rates are possible.

## 7.4 Thermal Information

THERMAL METRIC <sup>(1)</sup>		ISO774x			UNIT
		DWW (SOIC)	DW (SOIC)	DBQ (QSOP)	
		16 Pins	16 Pins	16 Pins	
$R_{\theta JA}$	Junction-to-ambient thermal resistance	58.3	83.4	109	°C/W
$R_{\theta JC(top)}$	Junction-to-case(top) thermal resistance	21.4	46	54.4	°C/W
$R_{\theta JB}$	Junction-to-board thermal resistance	30.5	48	51.9	°C/W
$\Psi_{JT}$	Junction-to-top characterization parameter	7.1	19.1	14.2	°C/W
$\Psi_{JB}$	Junction-to-board characterization parameter	29.8	47.5	51.4	°C/W
$R_{\theta JC(bottom)}$	Junction-to-case(bottom) thermal resistance	—	—	—	°C/W

(1) For more information about traditional and new thermal metrics, see the [Semiconductor and IC Package Thermal Metrics application report](#).

## 7.5 Power Rating

PARAMETER		TEST CONDITIONS	MIN	TYP	MAX	UNIT
<b>ISO7740</b>						
$P_D$	Maximum power dissipation	$V_{CC1} = V_{CC2} = 5.5\text{ V}$ , $T_J = 150^\circ\text{C}$ , $C_L = 15\text{ pF}$ , Input a 50-MHz 50% duty cycle square wave			200	mW
$P_{D1}$	Maximum power dissipation by side-1				40	mW
$P_{D2}$	Maximum power dissipation by side-2				160	mW
<b>ISO7741</b>						
$P_D$	Maximum power dissipation	$V_{CC1} = V_{CC2} = 5.5\text{ V}$ , $T_J = 150^\circ\text{C}$ , $C_L = 15\text{ pF}$ , Input a 50-MHz 50% duty cycle square wave			200	mW
$P_{D1}$	Maximum power dissipation by side-1				75	mW
$P_{D2}$	Maximum power dissipation by side-2				125	mW
<b>ISO7742</b>						
$P_D$	Maximum power dissipation	$V_{CC1} = V_{CC2} = 5.5\text{ V}$ , $T_J = 150^\circ\text{C}$ , $C_L = 15\text{ pF}$ , Input a 50-MHz 50% duty cycle square wave			200	mW
$P_{D1}$	Maximum power dissipation by side-1				100	mW
$P_{D2}$	Maximum power dissipation by side-2				100	mW

## 7.6 Insulation Specifications

PARAMETER	TEST CONDITIONS	VALUE		UNIT	
		DW-16	DBQ-16		
CLR External clearance <sup>(1)</sup>	Shortest terminal-to-terminal distance through air	>8	>3.7	mm	
CPG External creepage <sup>(1)</sup>	Shortest terminal-to-terminal distance across the package surface	>8	>3.7	mm	
DTI Distance through the insulation	Minimum internal gap (internal clearance)	>21	>21	μm	
CTI Comparative tracking index	DIN EN 60112 (VDE 0303-11); IEC 60112	>600	>600	V	
Material group	According to IEC 60664-1	I	I		
Overvoltage category per IEC 60664-1	Rated mains voltage ≤ 300 V <sub>RMS</sub>	I-IV	I-III		
	Rated mains voltage ≤ 600 V <sub>RMS</sub>	I-IV	n/a		
	Rated mains voltage ≤ 1000 V <sub>RMS</sub>	I-III	n/a		
<b>DIN VDE V 0884-11:2017-01<sup>(2)</sup></b>					
V <sub>IORM</sub> Maximum repetitive peak isolation voltage	AC voltage (bipolar)	ISO774x	2121	566	V <sub>PK</sub>
		ISO7741B	1414	n/a	
V <sub>IOWM</sub> Maximum working isolation voltage	AC voltage; Time dependent dielectric breakdown (TDDB) Test; see <a href="#">Figure 28</a>	ISO774x	1500	400	V <sub>RMS</sub>
		ISO7741B	1000	n/a	
	DC voltage	ISO774x	2121	566	V <sub>DC</sub>
		ISO7741B	1414	n/a	
V <sub>IOTM</sub> Maximum transient isolation voltage	V <sub>TEST</sub> = V <sub>IOTM</sub> , t = 60 s (qualification); V <sub>TEST</sub> = 1.2 × V <sub>IOTM</sub> , t = 1 s (100% production)		8000	4242	V <sub>PK</sub>
V <sub>IOSM</sub> Maximum surge isolation voltage <sup>(3)</sup>	Test method per IEC 62368-1, 1.2/50 μs waveform	V <sub>TEST</sub> = 1.6 × V <sub>IOSM</sub> (ISO774x)	8000	4000	V <sub>PK</sub>
		V <sub>TEST</sub> = 1.3 × V <sub>IOSM</sub> (ISO7741B)	6000	n/a	
q <sub>pd</sub> Apparent charge <sup>(4)</sup>	Method a, After Input/Output safety test subgroup 2/3, V <sub>ini</sub> = V <sub>IOTM</sub> , t <sub>ini</sub> = 60 s; V <sub>pd(m)</sub> = 1.2 × V <sub>IORM</sub> , t <sub>m</sub> = 10 s		≤5	≤5	pC
	Method a, After environmental tests subgroup 1, V <sub>ini</sub> = V <sub>IOTM</sub> , t <sub>ini</sub> = 60 s;	V <sub>pd(m)</sub> = 1.6 × V <sub>IORM</sub> , t <sub>m</sub> = 10 s (ISO774x)	≤5	≤5	
		V <sub>pd(m)</sub> = 1.2 × V <sub>IORM</sub> , t <sub>m</sub> = 10 s (ISO7741B)			
	Method b1; At routine test (100% production) and preconditioning (type test) V <sub>ini</sub> = 1.2 × V <sub>IOTM</sub> , t <sub>ini</sub> = 1 s;	V <sub>pd(m)</sub> = 1.875 × V <sub>IORM</sub> , t <sub>m</sub> = 1 s (ISO774x)	≤5	≤5	
V <sub>pd(m)</sub> = 1.5 × V <sub>IORM</sub> , t <sub>m</sub> = 1 s (ISO7741B)					
C <sub>IO</sub> Barrier capacitance, input to output <sup>(5)</sup>	V <sub>IO</sub> = 0.4 × sin(2πft), f = 1 MHz		~1	~1	pF
R <sub>IO</sub> Isolation resistance <sup>(5)</sup>	V <sub>IO</sub> = 500 V, T <sub>A</sub> = 25°C		>10 <sup>12</sup>	>10 <sup>12</sup>	Ω
	V <sub>IO</sub> = 500 V, 100°C ≤ T <sub>A</sub> ≤ 125°C		>10 <sup>11</sup>	>10 <sup>11</sup>	
	V <sub>IO</sub> = 500 V at T <sub>S</sub> = 150°C		>10 <sup>9</sup>	>10 <sup>9</sup>	
Pollution degree			2	2	
Climatic category			55/125/ 21	55/125/ 21	
<b>UL 1577</b>					
V <sub>ISO</sub> Maximum withstanding isolation voltage	V <sub>TEST</sub> = V <sub>ISO</sub> , t = 60 s (qualification), V <sub>TEST</sub> = 1.2 × V <sub>ISO</sub> , t = 1 s (100% production)		5000	3000	V <sub>RMS</sub>

- Creepage and clearance requirements should be applied according to the specific equipment isolation standards of an application. Care should be taken to maintain the creepage and clearance distance of a board design to ensure that the mounting pads of the isolator on the printed-circuit board do not reduce this distance. Creepage and clearance on a printed-circuit board become equal in certain cases. Techniques such as inserting grooves and/or ribs on a printed circuit board are used to help increase these specifications.
- This coupler is suitable for *safe electrical insulation (ISO774x)* and *basic electrical insulation (ISO7741B)* only within the safety ratings. Compliance with the safety ratings shall be ensured by means of suitable protective circuits.
- Testing is carried out in air or oil to determine the intrinsic surge immunity of the isolation barrier.
- Apparent charge is electrical discharge caused by a partial discharge (pd).
- All pins on each side of the barrier tied together creating a two-terminal device.

## 7.7 Safety-Related Certifications

VDE	CSA	UL	CQC	TUV
Certified according to DIN VDE V 0884-11:2017-01	Certified according to IEC 60950-1, IEC 62368-1 and IEC 60601-1	Certified according to UL 1577 Component Recognition Program	Certified according to GB 4943.1-2011	Certified according to EN 61010-1:2010/A1:2019, EN 60950-1:2006/A2:2013 and EN 62368-1:2014
Maximum transient isolation voltage, 8000 $V_{PK}$ (DW-16) and 4242 $V_{PK}$ (DBQ-16); Maximum repetitive peak isolation voltage, 2121 $V_{PK}$ (DW-16, Reinforced), 1414 $V_{PK}$ (DW-16, Basic) and 566 $V_{PK}$ (DBQ-16); Maximum surge isolation voltage, 8000 $V_{PK}$ (DW-16, Reinforced), 6000 $V_{PK}$ (DW-16, Basic) and 4000 $V_{PK}$ (DBQ-16)	Reinforced insulation per CSA 60950-1-07+A1+A2, IEC 60950-1 2nd Ed.+A1+A2, CSA 62368-1-14 and IEC 62368-1 2nd Ed. 800 $V_{RMS}$ (DW-16) and 370 $V_{RMS}$ (DBQ-16) max working voltage (pollution degree 2, material group I); 2 MOPP (Means of Patient Protection) per CSA 60601-1:14 and IEC 60601-1 Ed. 3.1, 250 $V_{RMS}$ (DW-16) max working voltage	<b>DW-16:</b> Single protection, 5000 $V_{RMS}$ ; <b>DBQ-16:</b> Single protection, 3000 $V_{RMS}$	<b>DW-16:</b> Reinforced Insulation, Altitude $\leq$ 5000 m, Tropical Climate, 700 $V_{RMS}$ maximum working voltage; <b>DBQ-16:</b> Basic Insulation, Altitude $\leq$ 5000 m, Tropical Climate, 400 $V_{RMS}$ maximum working voltage	5000 $V_{RMS}$ (DW-16) and 3000 $V_{RMS}$ (DBQ-16) Reinforced insulation per EN 61010-1:2010/A1:2019 up to working voltage of 600 $V_{RMS}$ (DW-16) and 300 $V_{RMS}$ (DBQ-16) 5000 $V_{RMS}$ (DW-16) and 3000 $V_{RMS}$ (DBQ-16) Reinforced insulation per EN 60950-1:2006/A2:2013 and EN 62368-1:2014 up to working voltage of 800 $V_{RMS}$ (DW-16) and 370 $V_{RMS}$ (DBQ-16)
Reinforced certificate: 40040142 Basic certificate: 40047657	Master contract number: 220991	File number: E181974	Certificate numbers: CQC15001121716 (DW-16) CQC18001199097 (DBQ-16)	Client ID number: 77311

## 7.8 Safety Limiting Values

Safety limiting<sup>(1)</sup> intends to minimize potential damage to the isolation barrier upon failure of input or output circuitry. A failure of the I/O can allow low resistance to ground or the supply and, without current limiting, dissipate sufficient power to overheat the die and damage the isolation barrier potentially leading to secondary system failures.

PARAMETER		TEST CONDITIONS	MIN	TYP	MAX	UNIT
<b>DW-16 PACKAGE</b>						
$I_S$	Safety input, output, or supply current	$R_{\theta JA} = 83.4 \text{ }^\circ\text{C/W}$ , $V_I = 5.5 \text{ V}$ , $T_J = 150^\circ\text{C}$ , $T_A = 25^\circ\text{C}$ , see <a href="#">Figure 1</a>			273	mA
		$R_{\theta JA} = 83.4 \text{ }^\circ\text{C/W}$ , $V_I = 3.6 \text{ V}$ , $T_J = 150^\circ\text{C}$ , $T_A = 25^\circ\text{C}$ , see <a href="#">Figure 1</a>			416	
		$R_{\theta JA} = 83.4 \text{ }^\circ\text{C/W}$ , $V_I = 2.75 \text{ V}$ , $T_J = 150^\circ\text{C}$ , $T_A = 25^\circ\text{C}$ , see <a href="#">Figure 1</a>			545	
$P_S$	Safety input, output, or total power	$R_{\theta JA} = 83.4 \text{ }^\circ\text{C/W}$ , $T_J = 150^\circ\text{C}$ , $T_A = 25^\circ\text{C}$ , see <a href="#">Figure 3</a>			1499	mW
$T_S$	Maximum safety temperature				150	$^\circ\text{C}$
<b>DBQ-16 PACKAGE</b>						
$I_S$	Safety input, output, or supply current	$R_{\theta JA} = 109 \text{ }^\circ\text{C/W}$ , $V_I = 5.5 \text{ V}$ , $T_J = 150^\circ\text{C}$ , $T_A = 25^\circ\text{C}$ , see <a href="#">Figure 2</a>			209	mA
		$R_{\theta JA} = 109 \text{ }^\circ\text{C/W}$ , $V_I = 3.6 \text{ V}$ , $T_J = 150^\circ\text{C}$ , $T_A = 25^\circ\text{C}$ , see <a href="#">Figure 2</a>			319	
		$R_{\theta JA} = 109 \text{ }^\circ\text{C/W}$ , $V_I = 2.75 \text{ V}$ , $T_J = 150^\circ\text{C}$ , $T_A = 25^\circ\text{C}$ , see <a href="#">Figure 2</a>			417	
$P_S$	Safety input, output, or total power	$R_{\theta JA} = 109 \text{ }^\circ\text{C/W}$ , $T_J = 150^\circ\text{C}$ , $T_A = 25^\circ\text{C}$ , see <a href="#">Figure 4</a>			1147	mW
$T_S$	Maximum safety temperature				150	$^\circ\text{C}$

- (1) The maximum safety temperature is the maximum junction temperature specified for the device. The power dissipation and junction-to-air thermal impedance of the device installed in the application hardware determines the junction temperature. The assumed junction-to-air thermal resistance in the [Thermal Information](#) is that of a device installed on a High-K test board for leaded Surface Mount Packages. The power is the recommended maximum input voltage times the current. The junction temperature is then the ambient temperature plus the power times the junction-to-air thermal resistance

## 7.9 Electrical Characteristics—5-V Supply

 $V_{CC1} = V_{CC2} = 5\text{ V} \pm 10\%$  (over recommended operating conditions unless otherwise noted)

PARAMETER	TEST CONDITIONS	MIN	TYP	MAX	UNIT
$V_{OH}$	High-level output voltage $I_{OH} = -4\text{ mA}$ ; see <a href="#">Figure 15</a>	$V_{CCO}^{(1)} - 0.4$	4.8		V
$V_{OL}$	Low-level output voltage $I_{OL} = 4\text{ mA}$ ; see <a href="#">Figure 15</a>		0.2	0.4	V
$V_{IT+(IN)}$	Rising input voltage threshold		$0.6 \times V_{CCI}$	$0.7 \times V_{CCI}$	V
$V_{IT-(IN)}$	Falling input voltage threshold	$0.3 \times V_{CCI}$	$0.4 \times V_{CCI}$		V
$V_{I(HYS)}$	Input threshold voltage hysteresis	$0.1 \times V_{CCI}$	$0.2 \times V_{CCI}$		V
$I_{IH}$	High-level input current $V_{IH} = V_{CCI}^{(1)}$ at INx or ENx			10	$\mu\text{A}$
$I_{IL}$	Low-level input current $V_{IL} = 0\text{ V}$ at INx or ENx	-10			$\mu\text{A}$
CMTI	Common-mode transient immunity $V_I = V_{CCI}$ or $0\text{ V}$ , $V_{CM} = 1200\text{ V}$ ; see <a href="#">Figure 18</a>	85	100		$\text{kV}/\mu\text{s}$
$C_I$	Input Capacitance <sup>(2)</sup> $V_I = V_{CC}/2 + 0.4 \times \sin(2\pi ft)$ , $f = 1\text{ MHz}$ , $V_{CC} = 5\text{ V}$		2		pF

 (1)  $V_{CCI}$  = Input-side  $V_{CC}$ ;  $V_{CCO}$  = Output-side  $V_{CC}$ .

(2) Measured from input pin to ground.

## 7.10 Supply Current Characteristics—5-V Supply

 $V_{CC1} = V_{CC2} = 5\text{ V} \pm 10\%$  (over recommended operating conditions unless otherwise noted).

PARAMETER	TEST CONDITIONS		SUPPLY CURRENT	MIN	TYP	MAX	UNIT	
<b>ISO7740</b>								
Supply current - Disable	EN2 = 0 V; V <sub>I</sub> = V <sub>CC1</sub> (ISO7740); V <sub>I</sub> = 0 V (ISO7740 with F suffix)		I <sub>CC1</sub>		1.2	1.6	mA	
			I <sub>CC2</sub>		0.3	0.5		
	EN2 = 0 V; V <sub>I</sub> = 0 V (ISO7740); V <sub>I</sub> = V <sub>CC1</sub> (ISO7740 with F suffix)		I <sub>CC1</sub>		5.5	7.8		
			I <sub>CC2</sub>		0.3	0.5		
Supply current - DC signal	EN2 = V <sub>CC2</sub> ; V <sub>I</sub> = V <sub>CC1</sub> (ISO7740); V <sub>I</sub> = 0 V (ISO7740 with F suffix)		I <sub>CC1</sub>		1.2	1.6		
			I <sub>CC2</sub>		2	3.2		
	EN2 = V <sub>CC2</sub> ; V <sub>I</sub> = 0 V (ISO7740); V <sub>I</sub> = V <sub>CC1</sub> (ISO7740 with F suffix)		I <sub>CC1</sub>		5.5	7.8		
			I <sub>CC2</sub>		2.2	3.6		
Supply current - AC signal	All channels switching with square wave clock input; C <sub>L</sub> = 15 pF		1 Mbps	I <sub>CC1</sub>		3.3	4.7	
				I <sub>CC2</sub>		2.3	3.6	
			10 Mbps	I <sub>CC1</sub>		3.4	4.8	
				I <sub>CC2</sub>		4.2	5.8	
			100 Mbps	I <sub>CC1</sub>		3.8	5.7	
				I <sub>CC2</sub>		22.7	28	
<b>ISO7741</b>								
Supply current - Disable	EN1 = EN2 = 0 V; V <sub>I</sub> = V <sub>CC1</sub> <sup>(1)</sup> (ISO7741); V <sub>I</sub> = 0 V (ISO7741 with F suffix)		I <sub>CC1</sub>		1	1.5	mA	
			I <sub>CC2</sub>		0.8	1.1		
	EN1 = EN2 = 0 V; V <sub>I</sub> = 0 V (ISO7741); V <sub>I</sub> = V <sub>CC1</sub> (ISO7741 with F suffix)		I <sub>CC1</sub>		4.3	6.3		
			I <sub>CC2</sub>		1.8	2.7		
Supply current - DC signal	EN1 = EN2 = V <sub>CC1</sub> ; V <sub>I</sub> = V <sub>CC1</sub> (ISO7741); V <sub>I</sub> = 0 V (ISO7741 with F suffix)		I <sub>CC1</sub>		1.5	2.3		
			I <sub>CC2</sub>		2	3		
	EN1 = EN2 = V <sub>CC1</sub> ; V <sub>I</sub> = 0 V (ISO7741); V <sub>I</sub> = V <sub>CC1</sub> (ISO7741 with F suffix)		I <sub>CC1</sub>		4.8	6.8		
			I <sub>CC2</sub>		3.2	4.9		
Supply current - AC signal	All channels switching with square wave clock input; C <sub>L</sub> = 15 pF		1 Mbps	I <sub>CC1</sub>		3.2	4.6	
				I <sub>CC2</sub>		2.8	4.1	
			10 Mbps	I <sub>CC1</sub>		3.7	5.2	
				I <sub>CC2</sub>		4.2	5.7	
			100 Mbps	I <sub>CC1</sub>		8.6	11.3	
				I <sub>CC2</sub>		18	22	
<b>ISO7742</b>								
Supply current - Disable	EN1 = EN2 = 0 V; V <sub>I</sub> = V <sub>CC1</sub> (ISO7742); V <sub>I</sub> = 0 V (ISO7742 with F suffix)		I <sub>CC1</sub> , I <sub>CC2</sub>		0.9	1.3	mA	
	EN1 = EN2 = 0 V; V <sub>I</sub> = 0 V (ISO7742); V <sub>I</sub> = V <sub>CC1</sub> (ISO7742 with F suffix)		I <sub>CC1</sub> , I <sub>CC2</sub>		3	4.6		
Supply current - DC signal	EN1 = EN2 = V <sub>CC1</sub> ; V <sub>I</sub> = V <sub>CC1</sub> (ISO7742); V <sub>I</sub> = 0 V (ISO7742 with F suffix)		I <sub>CC1</sub> , I <sub>CC2</sub>		1.7	2.7		
	EN1 = EN2 = V <sub>CC1</sub> ; V <sub>I</sub> = 0 V (ISO7742); V <sub>I</sub> = V <sub>CC1</sub> (ISO7742 with F suffix)		I <sub>CC1</sub> , I <sub>CC2</sub>		4	5.9		
Supply current - AC signal	All channels switching with square wave clock input; C <sub>L</sub> = 15 pF		1 Mbps	I <sub>CC1</sub> , I <sub>CC2</sub>		3		4.4
			10 Mbps	I <sub>CC1</sub> , I <sub>CC2</sub>		4		5.5
			100 Mbps	I <sub>CC1</sub> , I <sub>CC2</sub>		13.4	17	

 (1) V<sub>CC1</sub> = Input-side V<sub>CC</sub>

## 7.11 Electrical Characteristics—3.3-V Supply

 $V_{CC1} = V_{CC2} = 3.3 \text{ V} \pm 10\%$  (over recommended operating conditions unless otherwise noted)

PARAMETER		TEST CONDITIONS	MIN	TYP	MAX	UNIT
$V_{OH}$	High-level output voltage	$I_{OH} = -2 \text{ mA}$ ; see <a href="#">Figure 15</a>	$V_{CCO}^{(1)} - 0.3$	3.2		V
$V_{OL}$	Low-level output voltage	$I_{OL} = 2 \text{ mA}$ ; see <a href="#">Figure 15</a>		0.1	0.3	V
$V_{IT+(IN)}$	Rising input voltage threshold			$0.6 \times V_{CCI}$	$0.7 \times V_{CCI}$	V
$V_{IT-(IN)}$	Falling input voltage threshold		$0.3 \times V_{CCI}$	$0.4 \times V_{CCI}$		V
$V_{I(HYS)}$	Input threshold voltage hysteresis		$0.1 \times V_{CCI}$	$0.2 \times V_{CCI}$		V
$I_{IH}$	High-level input current	$V_{IH} = V_{CCI}^{(1)}$ at INx or ENx			10	$\mu\text{A}$
$I_{IL}$	Low-level input current	$V_{IL} = 0 \text{ V}$ at INx or ENx	-10			$\mu\text{A}$
CMTI	Common-mode transient immunity	$V_I = V_{CCI}$ or $0 \text{ V}$ , $V_{CM} = 1200 \text{ V}$ ; see <a href="#">Figure 18</a>	85	100		$\text{kV}/\mu\text{s}$

 (1)  $V_{CCI}$  = Input-side  $V_{CC}$ ;  $V_{CCO}$  = Output-side  $V_{CC}$ .

## 7.12 Supply Current Characteristics—3.3-V Supply

 $V_{CC1} = V_{CC2} = 3.3\text{ V} \pm 10\%$  (over recommended operating conditions unless otherwise noted).

PARAMETER	TEST CONDITIONS		SUPPLY CURRENT	MIN	TYP	MAX	UNIT
<b>ISO7740</b>							
Supply current - Disable	EN2 = 0 V; V <sub>I</sub> = V <sub>CC1</sub> (ISO7740); V <sub>I</sub> = 0 V (ISO7740 with F suffix)		I <sub>CC1</sub>		1.2	1.6	mA
			I <sub>CC2</sub>		0.3	0.5	
	EN2 = 0 V; V <sub>I</sub> = 0 V (ISO7740); V <sub>I</sub> = V <sub>CC1</sub> (ISO7740 with F suffix)		I <sub>CC1</sub>		5.5	7.8	
			I <sub>CC2</sub>		0.3	0.5	
Supply current - DC signal	EN2 = V <sub>CC2</sub> ; V <sub>I</sub> = V <sub>CC1</sub> (ISO7740); V <sub>I</sub> = 0 V (ISO7740 with F suffix)		I <sub>CC1</sub>		1.2	1.6	
			I <sub>CC2</sub>		1.9	3.2	
	EN2 = V <sub>CC2</sub> ; V <sub>I</sub> = 0 V (ISO7740); V <sub>I</sub> = V <sub>CC1</sub> (ISO7740 with F suffix)		I <sub>CC1</sub>		5.5	7.8	
			I <sub>CC2</sub>		2.2	3.6	
Supply current - AC signal	All channels switching with square wave clock input; C <sub>L</sub> = 15 pF	1 Mbps	I <sub>CC1</sub>		3.3	4.7	
			I <sub>CC2</sub>		2.2	3.6	
		10 Mbps	I <sub>CC1</sub>		3.4	4.8	
			I <sub>CC2</sub>		3.6	5	
		100 Mbps	I <sub>CC1</sub>		3.3	5.5	
			I <sub>CC2</sub>		17	20	
<b>ISO7741</b>							
Supply current - Disable	EN1 = EN2 = 0 V; V <sub>I</sub> = V <sub>CC1</sub> <sup>(1)</sup> (ISO7741); V <sub>I</sub> = 0 V (ISO7741 with F suffix)		I <sub>CC1</sub>		1	1.5	mA
			I <sub>CC2</sub>		0.8	1.1	
	EN1 = EN2 = 0 V; V <sub>I</sub> = 0 V (ISO7741); V <sub>I</sub> = V <sub>CC1</sub> (ISO7741 with F suffix)		I <sub>CC1</sub>		4.3	6.3	
			I <sub>CC2</sub>		1.9	2.7	
Supply current - DC signal	EN1 = EN2 = V <sub>CC1</sub> ; V <sub>I</sub> = V <sub>CC1</sub> (ISO7741); V <sub>I</sub> = 0 V (ISO7741 with F suffix)		I <sub>CC1</sub>		1.5	2.3	
			I <sub>CC2</sub>		2	3	
	EN1 = EN2 = V <sub>CC1</sub> ; V <sub>I</sub> = 0 V (ISO7741); V <sub>I</sub> = V <sub>CC1</sub> (ISO7741 with F suffix)		I <sub>CC1</sub>		4.8	6.8	
			I <sub>CC2</sub>		3.2	4.9	
Supply current - AC signal	All channels switching with square wave clock input; C <sub>L</sub> = 15 pF	1 Mbps	I <sub>CC1</sub>		3.2	4.6	
			I <sub>CC2</sub>		2.7	4.1	
		10 Mbps	I <sub>CC1</sub>		3.5	5	
			I <sub>CC2</sub>		3.7	5.2	
		100 Mbps	I <sub>CC1</sub>		6.8	9.3	
			I <sub>CC2</sub>		13.7	16.4	
<b>ISO7742</b>							
Supply current - Disable	EN1 = EN2 = 0 V; V <sub>I</sub> = V <sub>CC1</sub> (ISO7742); V <sub>I</sub> = 0 V (ISO7742 with F suffix)		I <sub>CC1</sub> , I <sub>CC2</sub>		0.9	1.3	mA
	EN1 = EN2 = 0 V; V <sub>I</sub> = 0 V (ISO7742); V <sub>I</sub> = V <sub>CC1</sub> (ISO7742 with F suffix)		I <sub>CC1</sub> , I <sub>CC2</sub>		3	4.6	
Supply current - DC signal	EN1 = EN2 = V <sub>CC1</sub> ; V <sub>I</sub> = V <sub>CC1</sub> (ISO7742); V <sub>I</sub> = 0 V (ISO7742 with F suffix)		I <sub>CC1</sub> , I <sub>CC2</sub>		1.7	2.7	
	EN1 = EN2 = V <sub>CC1</sub> ; V <sub>I</sub> = 0 V (ISO7742); V <sub>I</sub> = V <sub>CC1</sub> (ISO7742 with F suffix)		I <sub>CC1</sub> , I <sub>CC2</sub>		4	5.9	
Supply current - AC signal	All channels switching with square wave clock input; C <sub>L</sub> = 15 pF	1 Mbps	I <sub>CC1</sub> , I <sub>CC2</sub>		2.9	4.3	
		10 Mbps	I <sub>CC1</sub> , I <sub>CC2</sub>		3.6	5.1	
		100 Mbps	I <sub>CC1</sub> , I <sub>CC2</sub>		10.3	13	

 (1) V<sub>CC1</sub> = Input-side V<sub>CC</sub>

### 7.13 Electrical Characteristics—2.5-V Supply

 $V_{CC1} = V_{CC2} = 2.5 \text{ V} \pm 10\%$  (over recommended operating conditions unless otherwise noted)

PARAMETER		TEST CONDITIONS	MIN	TYP	MAX	UNIT
$V_{OH}$	High-level output voltage	$I_{OH} = -1 \text{ mA}$ ; see <a href="#">Figure 15</a>	$V_{CCO}^{(1)} - 0.2$	2.45		V
$V_{OL}$	Low-level output voltage	$I_{OL} = 1 \text{ mA}$ ; see <a href="#">Figure 15</a>		0.05	0.2	V
$V_{IT+(IN)}$	Rising input voltage threshold			$0.6 \times V_{CCI}$	$0.7 \times V_{CCI}$	V
$V_{IT-(IN)}$	Falling input voltage threshold		$0.3 \times V_{CCI}$	$0.4 \times V_{CCI}$		V
$V_{I(HYS)}$	Input threshold voltage hysteresis		$0.1 \times V_{CCI}$	$0.2 \times V_{CCI}$		V
$I_{IH}$	High-level input current	$V_{IH} = V_{CCI}^{(1)}$ at INx or ENx			10	$\mu\text{A}$
$I_{IL}$	Low-level input current	$V_{IL} = 0 \text{ V}$ at INx or ENx	-10			$\mu\text{A}$
CMTI	Common-mode transient immunity	$V_I = V_{CCI}$ or $0 \text{ V}$ , $V_{CM} = 1200 \text{ V}$ ; see <a href="#">Figure 18</a>	85	100		$\text{kV}/\mu\text{s}$

(1)  $V_{CCI}$  = Input-side  $V_{CC}$ ;  $V_{CCO}$  = Output-side  $V_{CC}$ .

## 7.14 Supply Current Characteristics—2.5-V Supply

 $V_{CC1} = V_{CC2} = 2.5\text{ V} \pm 10\%$  (over recommended operating conditions unless otherwise noted).

PARAMETER	TEST CONDITIONS		SUPPLY CURRENT	MIN	TYP	MAX	UNIT
<b>ISO7740</b>							
Supply current - Disable	EN2 = 0 V; V <sub>I</sub> = V <sub>CC1</sub> (ISO7740); V <sub>I</sub> = 0 V (ISO7740 with F suffix)		I <sub>CC1</sub>		1.2	1.6	mA
			I <sub>CC2</sub>		0.3	0.5	
	EN2 = 0 V; V <sub>I</sub> = 0 V (ISO7740); V <sub>I</sub> = V <sub>CC1</sub> (ISO7740 with F suffix)		I <sub>CC1</sub>		5.5	7.8	
			I <sub>CC2</sub>		0.3	0.5	
Supply current - DC signal	EN2 = V <sub>CC2</sub> ; V <sub>I</sub> = V <sub>CC1</sub> (ISO7740); V <sub>I</sub> = 0 V (ISO7740 with F suffix)		I <sub>CC1</sub>		1.2	1.6	
			I <sub>CC2</sub>		1.9	3.2	
	EN2 = V <sub>CC2</sub> ; V <sub>I</sub> = 0 V (ISO7740); V <sub>I</sub> = V <sub>CC1</sub> (ISO7740 with F suffix)		I <sub>CC1</sub>		5.4	7.8	
			I <sub>CC2</sub>		2.2	3.6	
Supply current - AC signal	All channels switching with square wave clock input; C <sub>L</sub> = 15 pF	1 Mbps	I <sub>CC1</sub>		3.3	4.7	
			I <sub>CC2</sub>		2.2	3.5	
		10 Mbps	I <sub>CC1</sub>		3.4	4.8	
			I <sub>CC2</sub>		3.2	4.7	
		100 Mbps	I <sub>CC1</sub>		3.2	5.4	
			I <sub>CC2</sub>		13	17	
<b>ISO7741</b>							
Supply current - Disable	EN1 = EN2 = 0 V; V <sub>I</sub> = V <sub>CCI</sub> <sup>(1)</sup> (ISO7741); V <sub>I</sub> = 0 V (ISO7741 with F suffix)		I <sub>CC1</sub>		1	1.5	mA
			I <sub>CC2</sub>		0.8	1.1	
	EN1 = EN2 = 0 V; V <sub>I</sub> = 0 V (ISO7741); V <sub>I</sub> = V <sub>CCI</sub> (ISO7741 with F suffix)		I <sub>CC1</sub>		4.3	6.3	
			I <sub>CC2</sub>		1.8	2.7	
Supply current - DC signal	EN1 = EN2 = V <sub>CCI</sub> ; V <sub>I</sub> = V <sub>CCI</sub> (ISO7741); V <sub>I</sub> = 0 V (ISO7741 with F suffix)		I <sub>CC1</sub>		1.4	2.3	
			I <sub>CC2</sub>		2	3	
	EN1 = EN2 = V <sub>CCI</sub> ; V <sub>I</sub> = 0 V (ISO7741); V <sub>I</sub> = V <sub>CCI</sub> (ISO7741 with F suffix)		I <sub>CC1</sub>		4.7	6.8	
			I <sub>CC2</sub>		3.2	4.9	
Supply current - AC signal	All channels switching with square wave clock input; C <sub>L</sub> = 15 pF	1 Mbps	I <sub>CC1</sub>		3.1	4.6	
			I <sub>CC2</sub>		2.7	4	
		10 Mbps	I <sub>CC1</sub>		3.4	4.9	
			I <sub>CC2</sub>		3.5	4.9	
		100 Mbps	I <sub>CC1</sub>		5.6	8.3	
			I <sub>CC2</sub>		10.8	13.8	
<b>ISO7742</b>							
Supply current - Disable	EN1 = EN2 = 0 V; V <sub>I</sub> = V <sub>CCI</sub> (ISO7742); V <sub>I</sub> = 0 V (ISO7742 with F suffix)		I <sub>CC1</sub> , I <sub>CC2</sub>		0.9	1.3	mA
	EN1 = EN2 = 0 V; V <sub>I</sub> = 0 V (ISO7742); V <sub>I</sub> = V <sub>CCI</sub> (ISO7742 with F suffix)		I <sub>CC1</sub> , I <sub>CC2</sub>		3	4.6	
Supply current - DC signal	EN1 = EN2 = V <sub>CCI</sub> ; V <sub>I</sub> = V <sub>CCI</sub> (ISO7742); V <sub>I</sub> = 0 V (ISO7742 with F suffix)		I <sub>CC1</sub> , I <sub>CC2</sub>		1.7	2.7	
	EN1 = EN2 = V <sub>CCI</sub> ; V <sub>I</sub> = 0 V (ISO7742); V <sub>I</sub> = V <sub>CCI</sub> (ISO7742 with F suffix)		I <sub>CC1</sub> , I <sub>CC2</sub>		4	5.9	
Supply current - AC signal	All channels switching with square wave clock input; C <sub>L</sub> = 15 pF	1 Mbps	I <sub>CC1</sub> , I <sub>CC2</sub>		2.9	4.3	
		10 Mbps	I <sub>CC1</sub> , I <sub>CC2</sub>		3.4	4.9	
		100 Mbps	I <sub>CC1</sub> , I <sub>CC2</sub>		8.3	11.5	

 (1) V<sub>CCI</sub> = Input-side V<sub>CC</sub>

## 7.15 Switching Characteristics—5-V Supply

 $V_{CC1} = V_{CC2} = 5\text{ V} \pm 10\%$  (over recommended operating conditions unless otherwise noted)

PARAMETER		TEST CONDITIONS	MIN	TYP	MAX	UNIT
$t_{PLH}$ , $t_{PHL}$	Propagation delay time	See <a href="#">Figure 15</a>	6	10.7	16	ns
PWD	Pulse width distortion <sup>(1)</sup> $ t_{PHL} - t_{PLH} $		0	4.9	ns	
$t_{sk(o)}$	Channel-to-channel output skew time <sup>(2)</sup>	Same-direction channels			4	ns
$t_{sk(pp)}$	Part-to-part skew time <sup>(3)</sup>				4.4	ns
$t_r$	Output signal rise time	See <a href="#">Figure 15</a>		2.4	3.9	ns
$t_f$	Output signal fall time			2.4	3.9	ns
$t_{PHZ}$	Disable propagation delay, high-to-high impedance output	See <a href="#">Figure 16</a>		9	20	ns
$t_{PLZ}$	Disable propagation delay, low-to-high impedance output			9	20	ns
$t_{PZH}$	Enable propagation delay, high impedance-to-high output for ISO774x			7	20	ns
	Enable propagation delay, high impedance-to-high output for ISO774x with F suffix			3	8.5	$\mu\text{s}$
$t_{PZL}$	Enable propagation delay, high impedance-to-low output for ISO774x			3	8.5	$\mu\text{s}$
	Enable propagation delay, high impedance-to-low output for ISO774x with F suffix			7	20	ns
$t_{DO}$	Default output delay time from input power loss	Measured from the time $V_{CC}$ goes below 1.7 V. See <a href="#">Figure 18</a>		0.1	0.3	$\mu\text{s}$
$t_{ie}$	Time interval error	$2^{16} - 1$ PRBS data at 100 Mbps		0.8		ns

- (1) Also known as pulse skew.
- (2)  $t_{sk(o)}$  is the skew between outputs of a single device with all driving inputs connected together and the outputs switching in the same direction while driving identical loads.
- (3)  $t_{sk(pp)}$  is the magnitude of the difference in propagation delay times between any terminals of different devices switching in the same direction while operating at identical supply voltages, temperature, input signals and loads.

## 7.16 Switching Characteristics—3.3-V Supply

 $V_{CC1} = V_{CC2} = 3.3\text{ V} \pm 10\%$  (over recommended operating conditions unless otherwise noted)

PARAMETER		TEST CONDITIONS	MIN	TYP	MAX	UNIT
$t_{PLH}$ , $t_{PHL}$	Propagation delay time	See <a href="#">Figure 15</a>	6	11	16	ns
PWD	Pulse width distortion <sup>(1)</sup> $ t_{PHL} - t_{PLH} $		0.1	5	ns	
$t_{sk(o)}$	Channel-to-channel output skew time <sup>(2)</sup>	Same-direction channels			4.1	ns
$t_{sk(pp)}$	Part-to-part skew time <sup>(3)</sup>				4.5	ns
$t_r$	Output signal rise time	See <a href="#">Figure 15</a>		1.3	3	ns
$t_f$	Output signal fall time			1.3	3	ns
$t_{PHZ}$	Disable propagation delay, high-to-high impedance output	See <a href="#">Figure 16</a>		17	30	ns
$t_{PLZ}$	Disable propagation delay, low-to-high impedance output			17	30	ns
$t_{PZH}$	Enable propagation delay, high impedance-to-high output for ISO774x			17	30	ns
	Enable propagation delay, high impedance-to-high output for ISO774x with F suffix			3.2	8.5	$\mu\text{s}$
$t_{PZL}$	Enable propagation delay, high impedance-to-low output for ISO774x			3.2	8.5	$\mu\text{s}$
	Enable propagation delay, high impedance-to-low output for ISO774x with F suffix			17	30	ns
$t_{DO}$	Default output delay time from input power loss	Measured from the time $V_{CC}$ goes below 1.7 V. See <a href="#">Figure 18</a>		0.1	0.3	$\mu\text{s}$
$t_{ie}$	Time interval error	$2^{16} - 1$ PRBS data at 100 Mbps		0.9		ns

- (1) Also known as pulse skew.
- (2)  $t_{sk(o)}$  is the skew between outputs of a single device with all driving inputs connected together and the outputs switching in the same direction while driving identical loads.
- (3)  $t_{sk(pp)}$  is the magnitude of the difference in propagation delay times between any terminals of different devices switching in the same direction while operating at identical supply voltages, temperature, input signals and loads.

## 7.17 Switching Characteristics—2.5-V Supply

 $V_{CC1} = V_{CC2} = 2.5\text{ V} \pm 10\%$  (over recommended operating conditions unless otherwise noted)

PARAMETER		TEST CONDITIONS	MIN	TYP	MAX	UNIT
$t_{PLH}, t_{PHL}$	Propagation delay time	See <a href="#">Figure 15</a>	7.5	12	18.5	ns
PWD	Pulse width distortion <sup>(1)</sup> $ t_{PHL} - t_{PLH} $		0.2	5.1		ns
$t_{sk(o)}$	Channel-to-channel output skew time <sup>(2)</sup>	Same-direction Channels			4.1	ns
$t_{sk(pp)}$	Part-to-part skew time <sup>(3)</sup>				4.6	ns
$t_r$	Output signal rise time	See <a href="#">Figure 15</a>		1	3.5	ns
$t_f$	Output signal fall time			1	3.5	ns
$t_{PHZ}$	Disable propagation delay, high-to-high impedance output	See <a href="#">Figure 16</a>		22	40	ns
$t_{PLZ}$	Disable propagation delay, low-to-high impedance output			22	40	ns
$t_{pZH}$	Enable propagation delay, high impedance-to-high output for ISO774x			18	40	ns
	Enable propagation delay, high impedance-to-high output for ISO774x with F suffix			3.3	8.5	$\mu\text{s}$
$t_{pZL}$	Enable propagation delay, high impedance-to-low output for ISO774x			3.3	8.5	$\mu\text{s}$
	Enable propagation delay, high impedance-to-low output for ISO774x with F suffix			18	40	ns
$t_{DO}$	Default output delay time from input power loss	Measured from the time $V_{CC}$ goes below 1.7 V. See <a href="#">Figure 18</a>		0.1	0.3	$\mu\text{s}$
$t_{ie}$	Time interval error	$2^{16} - 1$ PRBS data at 100 Mbps		0.7		ns

- (1) Also known as pulse skew.
- (2)  $t_{sk(o)}$  is the skew between outputs of a single device with all driving inputs connected together and the outputs switching in the same direction while driving identical loads.
- (3)  $t_{sk(pp)}$  is the magnitude of the difference in propagation delay times between any terminals of different devices switching in the same direction while operating at identical supply voltages, temperature, input signals and loads.

### 7.18 Insulation Characteristics Curves

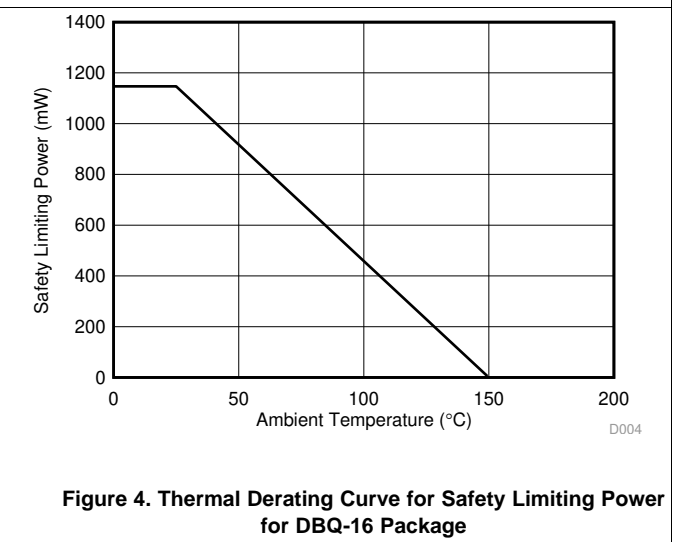
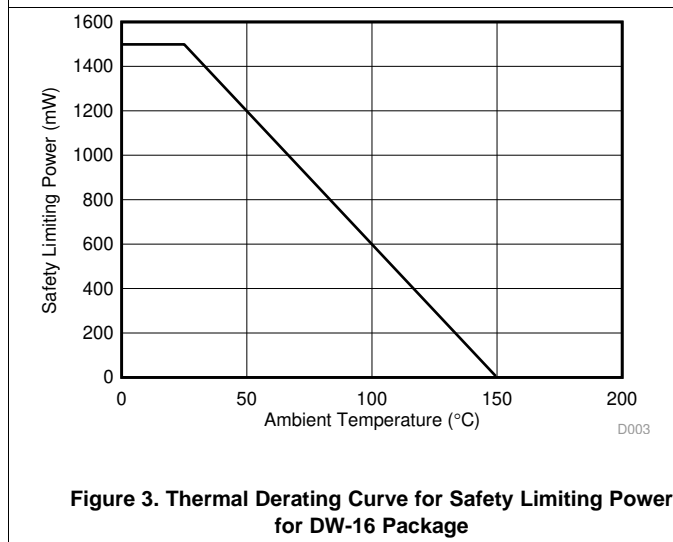
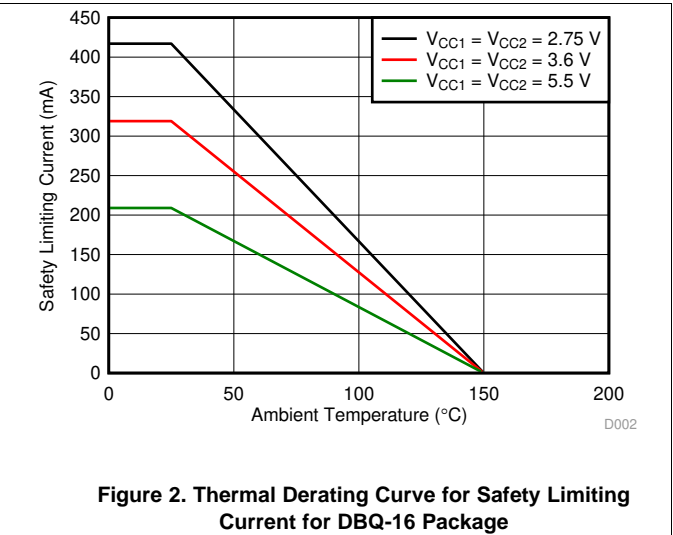
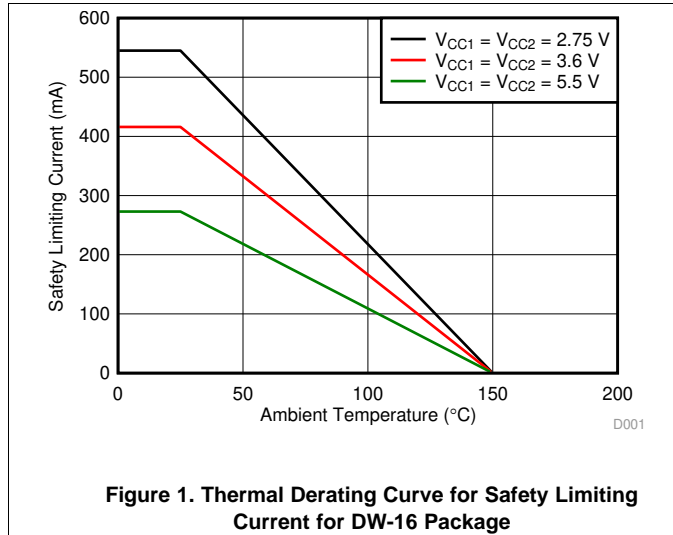

### 7.19 Typical Characteristics

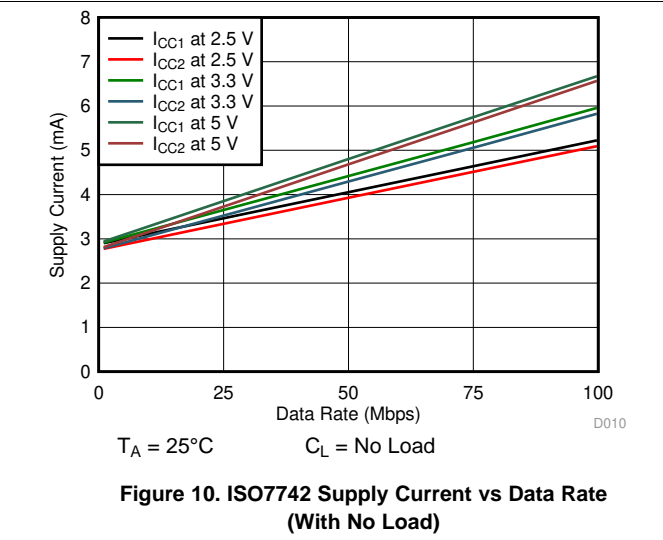
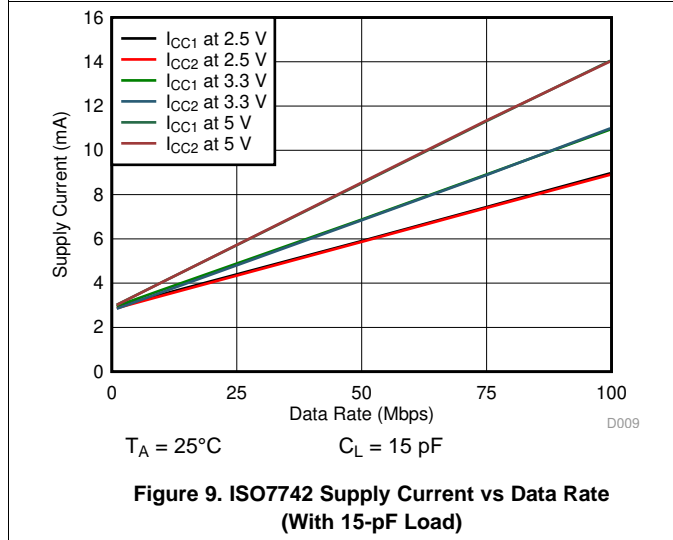
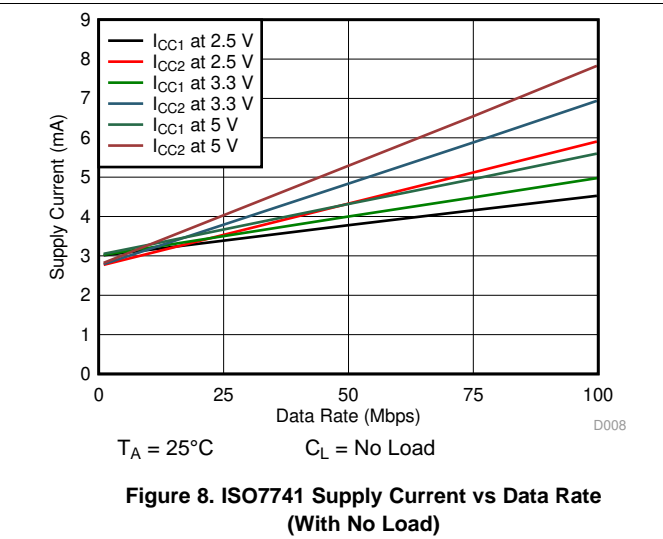
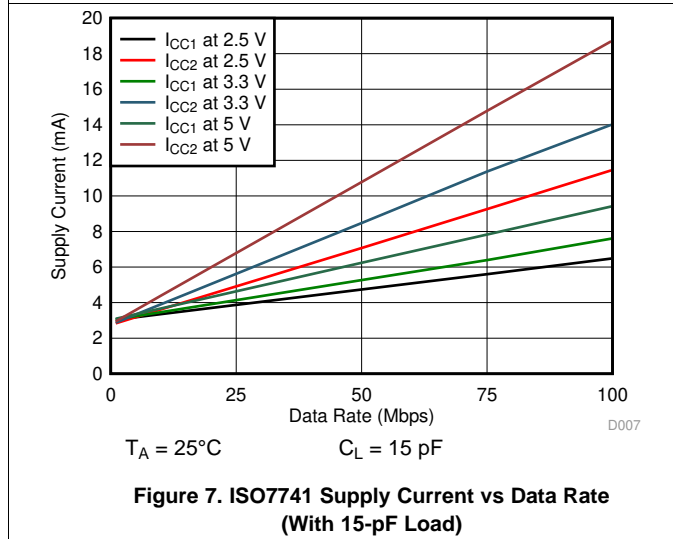
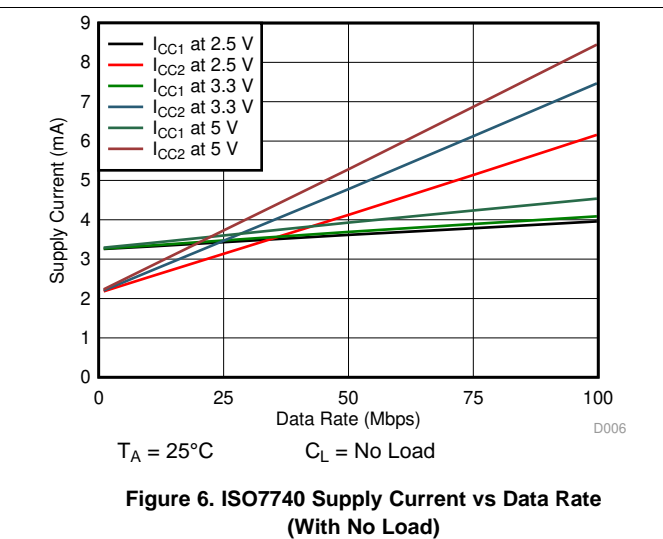
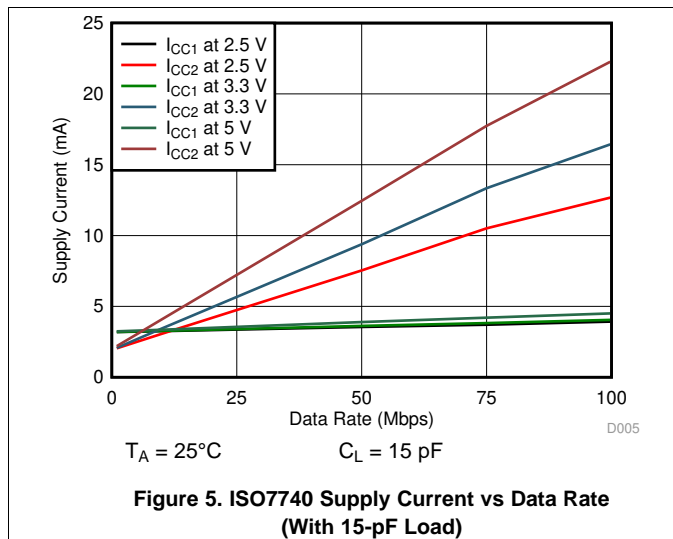

Typical Characteristics (continued)

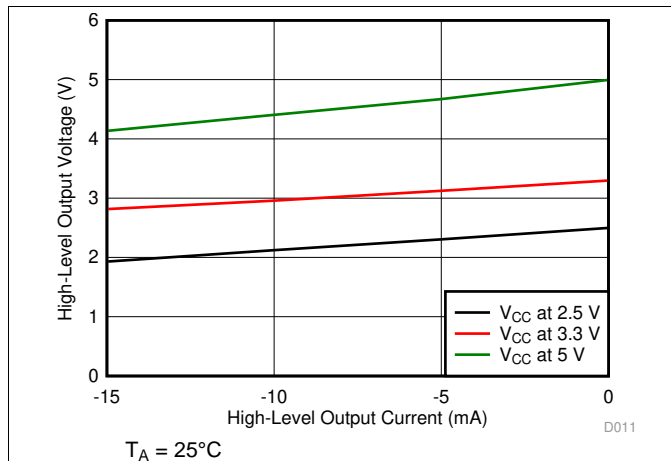

Figure 11. High-Level Output Voltage vs High-level Output Current

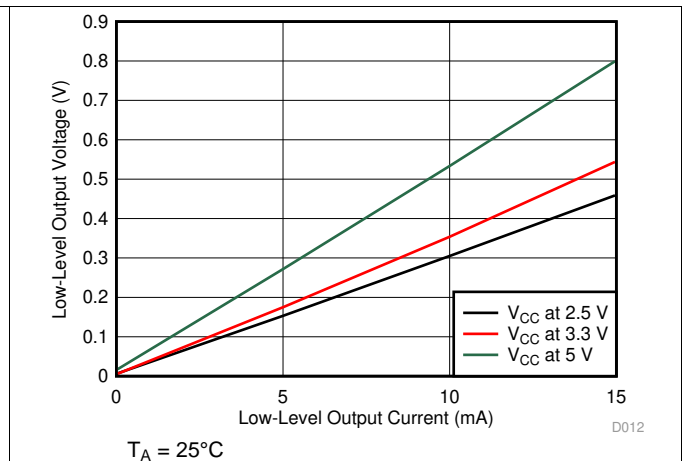

Figure 12. Low-Level Output Voltage vs Low-Level Output Current

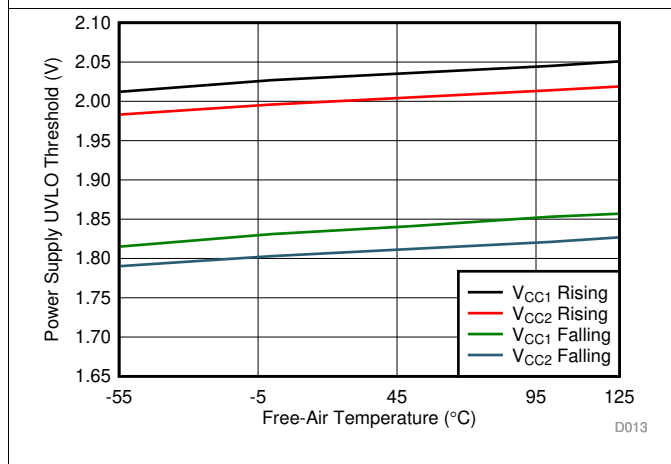

Figure 13. Power Supply Undervoltage Threshold vs Free-Air Temperature

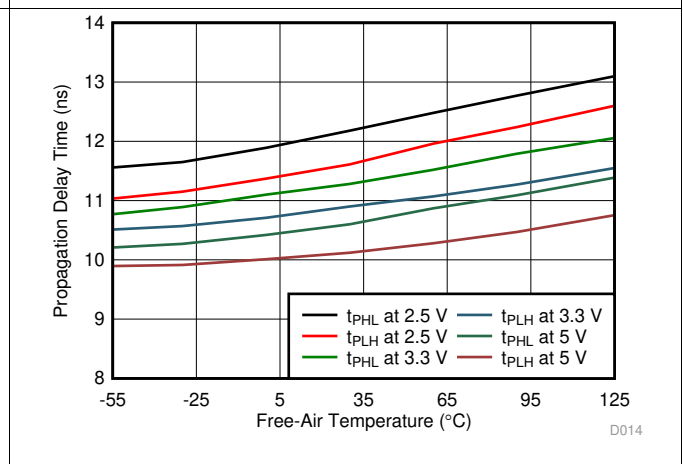
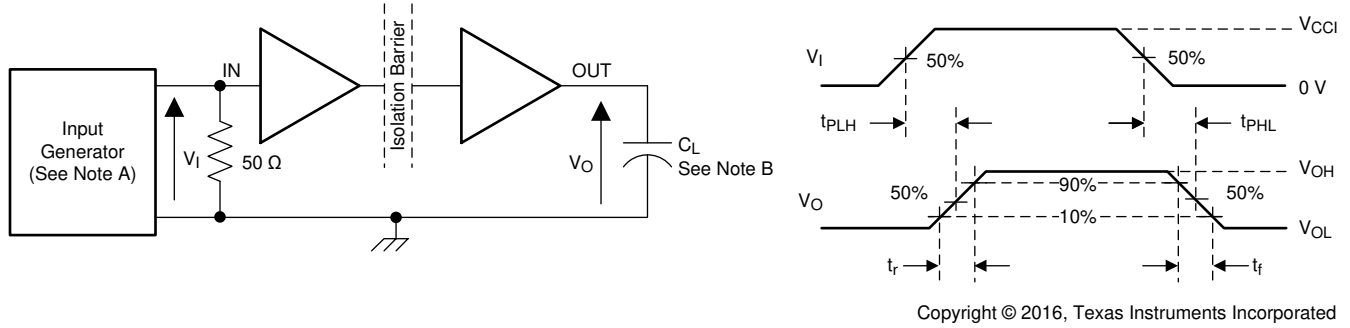

Figure 14. Propagation Delay Time vs Free-Air Temperature

## 8 Parameter Measurement Information



- A. The input pulse is supplied by a generator having the following characteristics: PRR  $\leq$  50 kHz, 50% duty cycle,  $t_r \leq$  3 ns,  $t_f \leq$  3 ns,  $Z_O = 50 \Omega$ . At the input,  $50 \Omega$  resistor is required to terminate Input Generator signal. It is not needed in actual application.
- B.  $C_L = 15$  pF and includes instrumentation and fixture capacitance within  $\pm 20\%$ .

Figure 15. Switching Characteristics Test Circuit and Voltage Waveforms

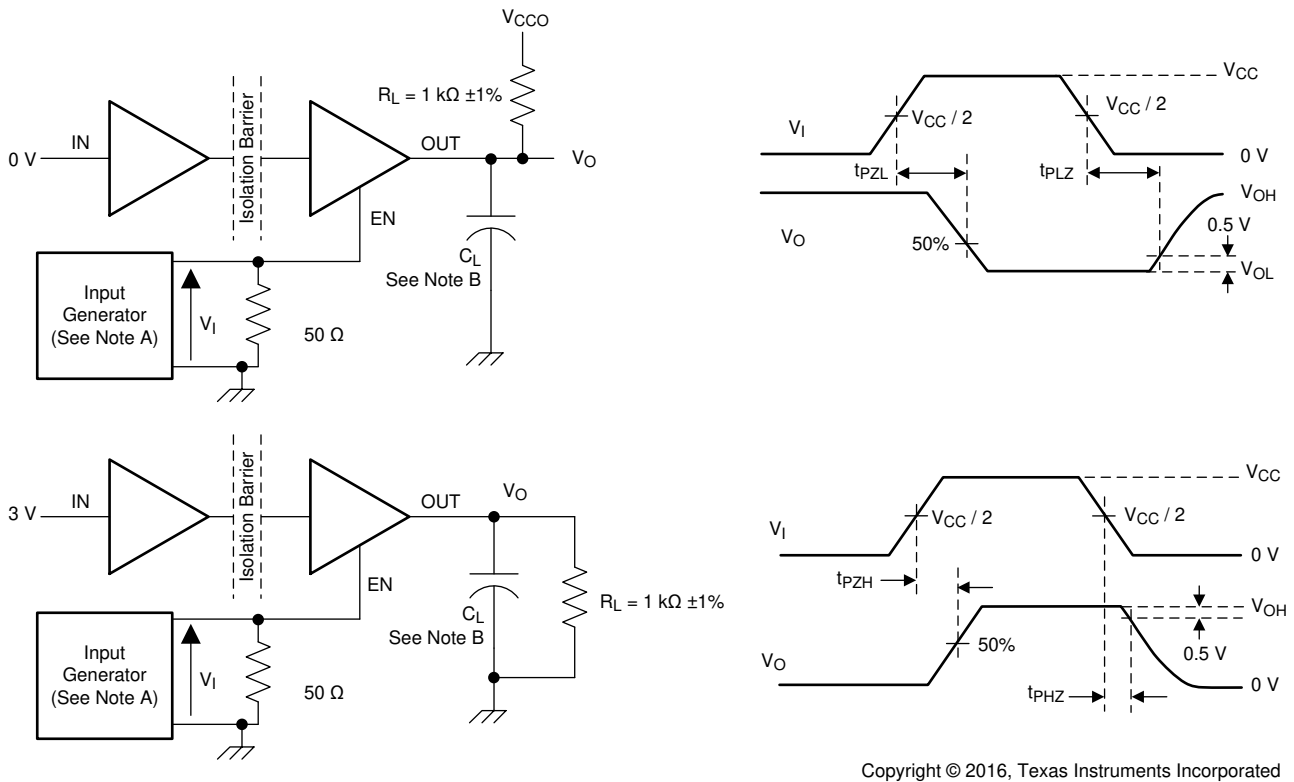

- A. The input pulse is supplied by a generator having the following characteristics: PRR  $\leq$  10 kHz, 50% duty cycle,  $t_r \leq$  3 ns,  $t_f \leq$  3 ns,  $Z_O = 50 \Omega$ .
- B.  $C_L = 15$  pF and includes instrumentation and fixture capacitance within  $\pm 20\%$ .

Figure 16. Enable/Disable Propagation Delay Time Test Circuit and Waveform



## 9 Detailed Description

### 9.1 Overview

The ISO774x family of devices uses an ON-OFF keying (OOK) modulation scheme to transmit the digital data across a silicon dioxide based isolation barrier. The transmitter sends a high frequency carrier across the barrier to represent one digital state and sends no signal to represent the other digital state. The receiver demodulates the signal after advanced signal conditioning and produces the output through a buffer stage. If the ENx pin is low then the output goes to high impedance. The ISO774x devices also incorporate advanced circuit techniques to maximize the CMTI performance and minimize the radiated emissions due to the high frequency carrier and IO buffer switching. The conceptual block diagram of a digital capacitive isolator, [Figure 19](#), shows a functional block diagram of a typical channel.

### 9.2 Functional Block Diagram

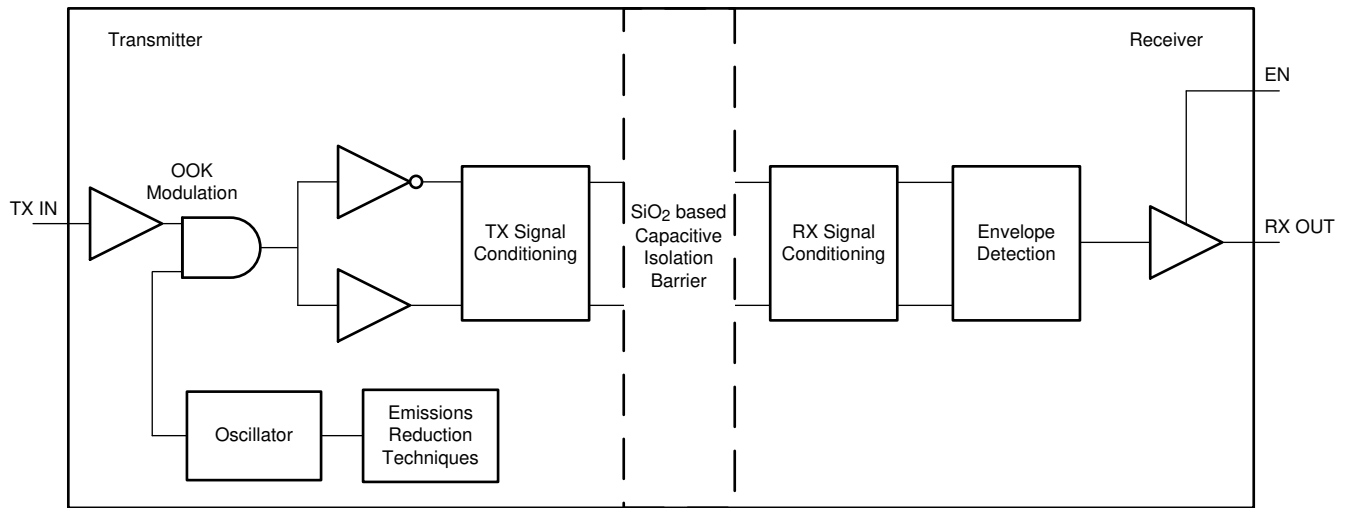

Copyright © 2016, Texas Instruments Incorporated

**Figure 19. Conceptual Block Diagram of a Digital Capacitive Isolator**

[Figure 20](#) shows a conceptual detail of how the ON-OFF keying scheme works.

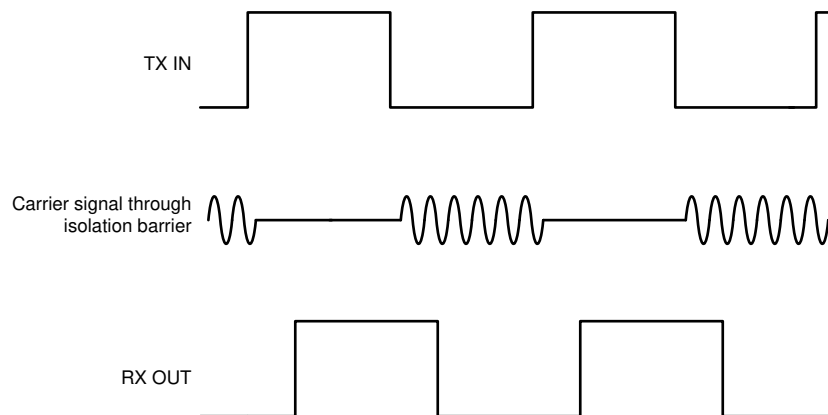

**Figure 20. On-Off Keying (OOK) Based Modulation Scheme**

### 9.3 Feature Description

Table 1 provides an overview of the device features.

**Table 1. Device Features**

PART NUMBER	CHANNEL DIRECTION	MAXIMUM DATA RATE	DEFAULT OUTPUT	PACKAGE	RATED ISOLATION <sup>(1)</sup>
ISO7740	4 Forward, 0 Reverse	100 Mbps	High	DW-16	5000 V <sub>RMS</sub> / 8000 V <sub>PK</sub>
				DBQ-16	3000 V <sub>RMS</sub> / 4242 V <sub>PK</sub>
ISO7740 with F suffix	4 Forward, 0 Reverse	100 Mbps	Low	DW-16	5000 V <sub>RMS</sub> / 8000 V <sub>PK</sub>
				DBQ-16	3000 V <sub>RMS</sub> / 4242 V <sub>PK</sub>
ISO7741	3 Forward, 1 Reverse	100 Mbps	High	DW-16	5000 V <sub>RMS</sub> / 8000 V <sub>PK</sub>
				DBQ-16	3000 V <sub>RMS</sub> / 4242 V <sub>PK</sub>
ISO7741 with F suffix	3 Forward, 1 Reverse	100 Mbps	Low	DW-16	5000 V <sub>RMS</sub> / 8000 V <sub>PK</sub>
				DBQ-16	3000 V <sub>RMS</sub> / 4242 V <sub>PK</sub>
ISO7741B	3 Forward, 1 Reverse	100 Mbps	High	DW-16	5000 V <sub>RMS</sub> / 8000 V <sub>PK</sub>
ISO7741B with F suffix	3 Forward, 1 Reverse	100 Mbps	Low	DW-16	5000 V <sub>RMS</sub> / 8000 V <sub>PK</sub>
ISO7742	2 Forward, 2 Reverse	100 Mbps	High	DW-16	5000 V <sub>RMS</sub> / 8000 V <sub>PK</sub>
				DBQ-16	3000 V <sub>RMS</sub> / 4242 V <sub>PK</sub>
ISO7742 with F suffix	2 Forward, 2 Reverse	100 Mbps	Low	DW-16	5000 V <sub>RMS</sub> / 8000 V <sub>PK</sub>
				DBQ-16	3000 V <sub>RMS</sub> / 4242 V <sub>PK</sub>

(1) See [Safety-Related Certifications](#) for detailed isolation ratings.

#### 9.3.1 Electromagnetic Compatibility (EMC) Considerations

Many applications in harsh industrial environment are sensitive to disturbances such as electrostatic discharge (ESD), electrical fast transient (EFT), surge and electromagnetic emissions. These electromagnetic disturbances are regulated by international standards such as IEC 61000-4-x and CISPR 22. Although system-level performance and reliability depends, to a large extent, on the application board design and layout, the ISO774x family of devices incorporates many chip-level design improvements for overall system robustness. Some of these improvements include:

- Robust ESD protection cells for input and output signal pins and inter-chip bond pads.
- Low-resistance connectivity of ESD cells to supply and ground pins.
- Enhanced performance of high voltage isolation capacitor for better tolerance of ESD, EFT and surge events.
- Bigger on-chip decoupling capacitors to bypass undesirable high energy signals through a low impedance path.
- PMOS and NMOS devices isolated from each other by using guard rings to avoid triggering of parasitic SCRs.
- Reduced common mode currents across the isolation barrier by ensuring purely differential internal operation.

## 9.4 Device Functional Modes

Table 2 lists the functional modes for the ISO774x devices.

**Table 2. Function Table<sup>(1)</sup>**

$V_{CCI}$	$V_{CCO}$	INPUT (INx) <sup>(2)</sup>	OUTPUT ENABLE (ENx)	OUTPUT (OUTx)	COMMENTS
PU	PU	H	H or open	H	Normal Operation: A channel output assumes the logic state of its input.
		L	H or open	L	
		Open	H or open	Default	Default mode: When INx is open, the corresponding channel output goes to its default logic state. Default is <i>High</i> for ISO774x and <i>Low</i> for ISO774x with F suffix.
X	PU	X	L	Z	A low value of output enable causes the outputs to be high-impedance.
PD	PU	X	H or open	Default	Default mode: When $V_{CCI}$ is unpowered, a channel output assumes the logic state based on the selected default option. Default is <i>High</i> for ISO774x and <i>Low</i> for ISO774x with F suffix. When $V_{CCI}$ transitions from unpowered to powered-up, a channel output assumes the logic state of the input. When $V_{CCI}$ transitions from powered-up to unpowered, channel output assumes the selected default state.
X	PD	X	X	Undetermined	When $V_{CCO}$ is unpowered, a channel output is undetermined <sup>(3)</sup> . When $V_{CCO}$ transitions from unpowered to powered-up, a channel output assumes the logic state of the input.

- (1)  $V_{CCI}$  = Input-side  $V_{CC}$ ;  $V_{CCO}$  = Output-side  $V_{CC}$ ; PU = Powered up ( $V_{CC} \geq 2.25$  V); PD = Powered down ( $V_{CC} \leq 1.7$  V); X = Irrelevant; H = High level; L = Low level; Z = High Impedance  
 (2) A strongly driven input signal can weakly power the floating  $V_{CC}$  through an internal protection diode and cause undetermined output.  
 (3) The outputs are in undetermined state when  $1.7$  V <  $V_{CCI}$ ,  $V_{CCO}$  <  $2.25$  V.

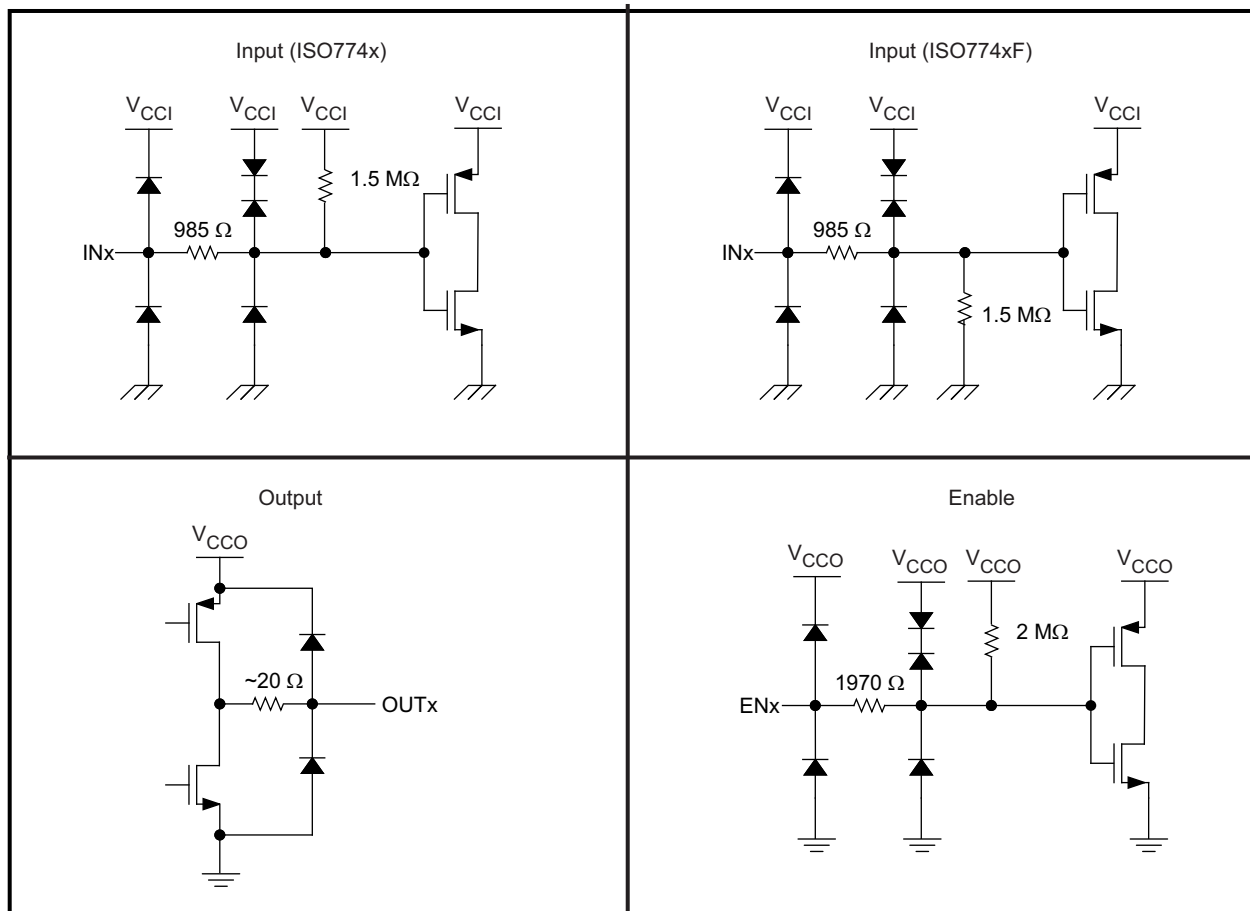
**9.4.1 Device I/O Schematics**

Copyright © 2016, Texas Instruments Incorporated

**Figure 21. Device I/O Schematics**



## Typical Application (continued)

### 10.2.1 Design Requirements

To design with these devices, use the parameters listed in [Table 3](#).

**Table 3. Design Parameters**

PARAMETER	VALUE
Supply voltage, $V_{CC1}$ and $V_{CC2}$	2.25 to 5.5 V
Decoupling capacitor between $V_{CC1}$ and GND1	0.1 $\mu$ F
Decoupling capacitor from $V_{CC2}$ and GND2	0.1 $\mu$ F

### 10.2.2 Detailed Design Procedure

Unlike optocouplers, which require external components to improve performance, provide bias, or limit current, the ISO774x family of devices only require two external bypass capacitors to operate.

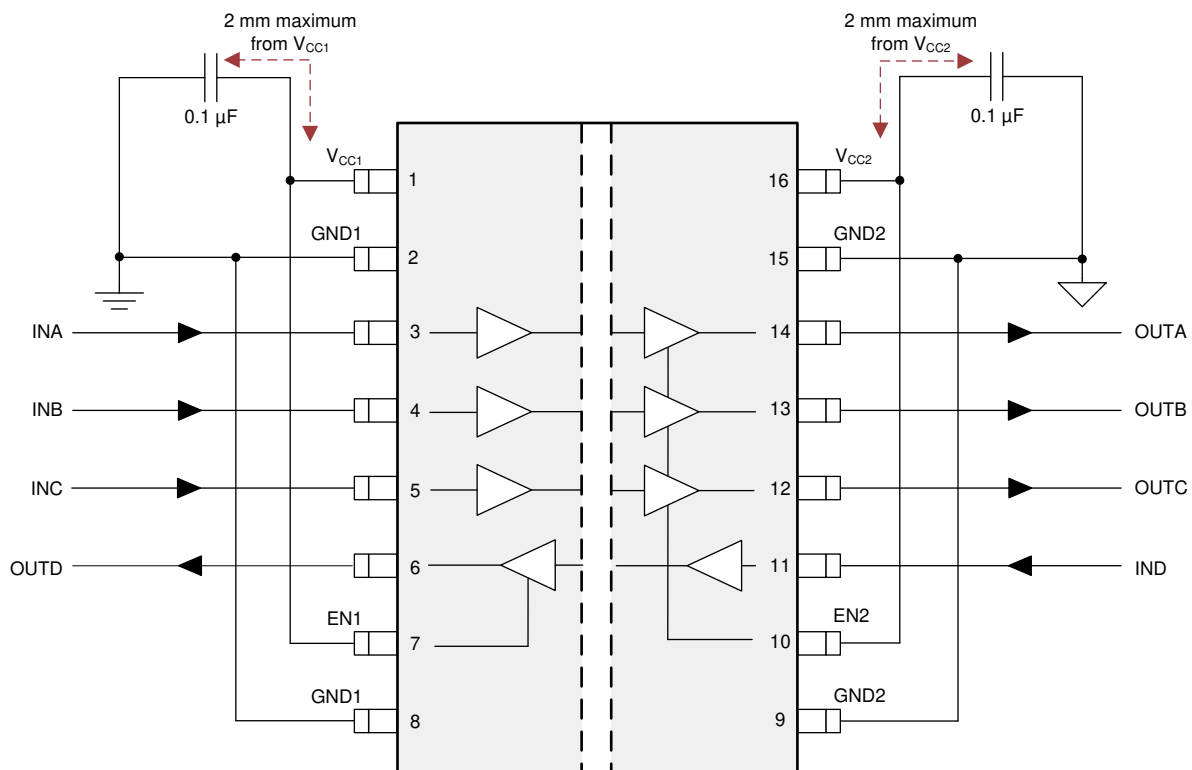
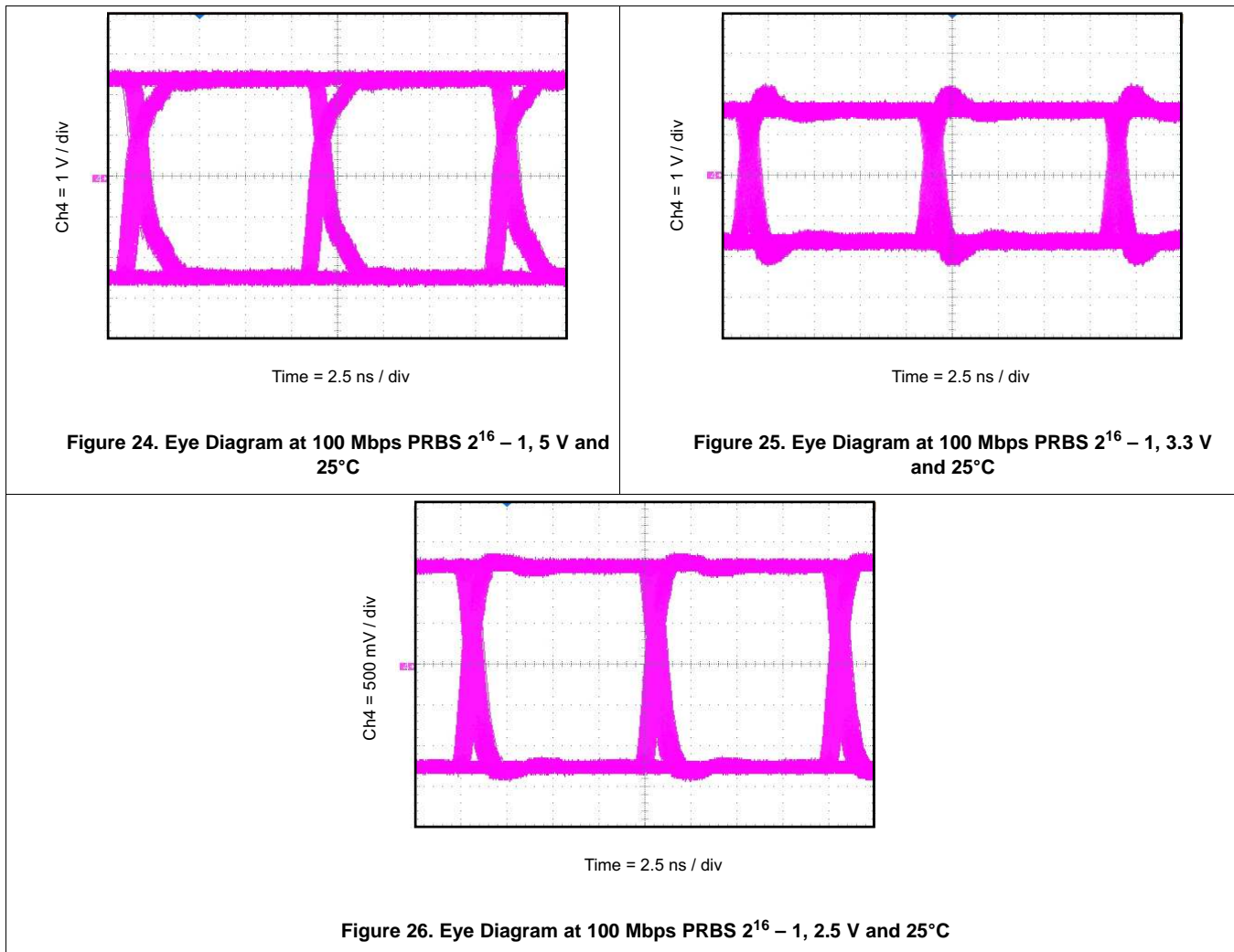

**Figure 23. Typical ISO774x Circuit Hook-up**

The DWW package provides wider creepage and clearance without the need for two isolators in series or an extra isolated power supply, saving design cost and board space. For more details, please refer to the technical document [How to Meet the Higher Isolation Creepage & Clearance Needs in Automotive Applications](#).

### 10.2.3 Application Curve

The following typical eye diagrams of the ISO774x family of devices indicates low jitter and wide open eye at the maximum data rate of 100 Mbps.



#### 10.2.3.1 Insulation Lifetime

Insulation lifetime projection data is collected by using industry-standard Time Dependent Dielectric Breakdown (TDDB) test method. In this test, all pins on each side of the barrier are tied together creating a two-terminal device and high voltage applied between the two sides; See [Figure 27](#) for TDDB test setup. The insulation breakdown data is collected at various high voltages switching at 60 Hz over temperature. For reinforced insulation, VDE standard requires the use of TDDB projection line with failure rate of less than 1 part per million (ppm). Even though the expected minimum insulation lifetime is 20 years at the specified working isolation voltage, VDE reinforced certification requires additional safety margin of 20% for working voltage and 87.5% for lifetime which translates into minimum required insulation lifetime of 37.5 years at a working voltage that's 20% higher than the specified value.

[Figure 28](#) shows the intrinsic capability of the isolation barrier to withstand high voltage stress over its lifetime. Based on the TDDB data, the insulation withstand capability of DW-16 package is 1500 V<sub>RMS</sub> with a lifetime of 135 years as illustrated in [Figure 28](#). Similarly, the insulation withstand capability of DWW-16 package is 2000 V<sub>RMS</sub> with a corresponding lifetime of 34 years. DBQ-16 package at 400 V<sub>RMS</sub> working voltage has a much longer lifetime than both DW-16 and DWW-16 packages. Factors, such as package size, pollution degree, and material group can limit the working voltage of a component.

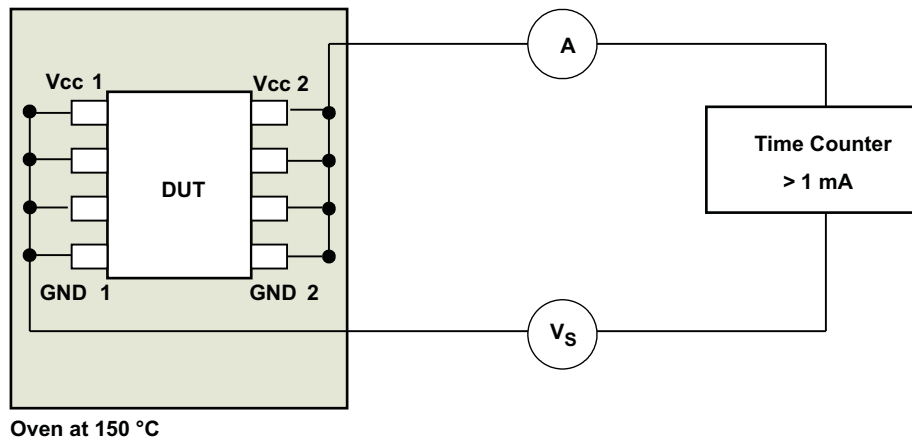

Figure 27. Test Setup for Insulation Lifetime Measurement

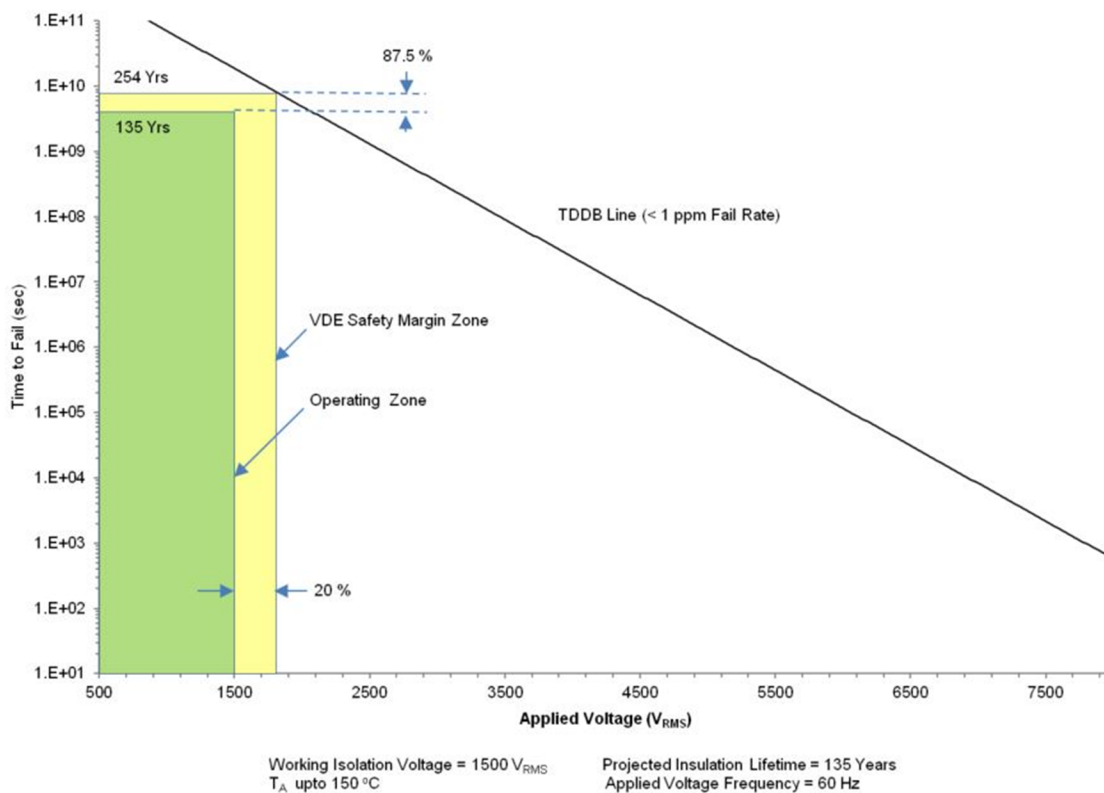

Figure 28. Insulation Lifetime Projection Data

## 11 Power Supply Recommendations

To help ensure reliable operation at data rates and supply voltages, a 0.1- $\mu$ F bypass capacitor is recommended at the input and output supply pins ( $V_{CC1}$  and  $V_{CC2}$ ). The capacitors should be placed as close to the supply pins as possible. If only a single primary-side power supply is available in an application, isolated power can be generated for the secondary-side with the help of a transformer driver such as Texas Instruments' [SN6501](#) or [SN6505A](#). For such applications, detailed power supply design and transformer selection recommendations are available in [SN6501 Transformer Driver for Isolated Power Supplies data sheet](#) or [SN6505A Low-Noise 1-A Transformer Drivers for Isolated Power Supplies data sheet](#).

## 12 Layout

### 12.1 Layout Guidelines

A minimum of four layers is required to accomplish a low EMI PCB design (see [Figure 29](#)). Layer stacking should be in the following order (top-to-bottom): high-speed signal layer, ground plane, power plane and low-frequency signal layer.

- Routing the high-speed traces on the top layer avoids the use of vias (and the introduction of their inductances) and allows for clean interconnects between the isolator and the transmitter and receiver circuits of the data link.
- Placing a solid ground plane next to the high-speed signal layer establishes controlled impedance for transmission line interconnects and provides an excellent low-inductance path for the return current flow.
- Placing the power plane next to the ground plane creates additional high-frequency bypass capacitance of approximately 100 pF/inch<sup>2</sup>.
- Routing the slower speed control signals on the bottom layer allows for greater flexibility as these signal links usually have margin to tolerate discontinuities such as vias.

If an additional supply voltage plane or signal layer is needed, add a second power or ground plane system to the stack to keep it symmetrical. This makes the stack mechanically stable and prevents it from warping. Also the power and ground plane of each power system can be placed closer together, thus increasing the high-frequency bypass capacitance significantly.

For detailed layout recommendations, refer to the [Digital Isolator Design Guide](#).

#### 12.1.1 PCB Material

For digital circuit boards operating below 150 Mbps, (or rise and fall times higher than 1 ns), and trace lengths of up to 10 inches, use standard FR-4 UL94V-0 printed circuit boards. This PCB is preferred over cheaper alternatives due to its lower dielectric losses at high frequencies, less moisture absorption, greater strength and stiffness, and self-extinguishing flammability-characteristics.

### 12.2 Layout Example

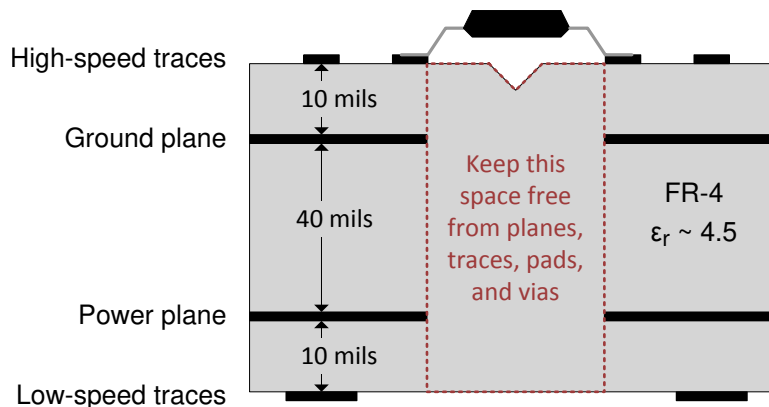

Figure 29. Layout Example Schematic

## 13 Device and Documentation Support

### 13.1 Documentation Support

#### 13.1.1 Related Documentation

For related documentation, see the following:

- Texas Instruments, [ADS79xx 12/10/8-Bit, 1 MSPS, 16/12/8/4-Channel, Single-Ended, MicroPower, Serial Interface ADCs data sheet](#)
- Texas Instruments, [Digital Isolator Design Guide](#)
- Texas Instruments, [Isolation Glossary](#)
- Texas Instruments, [How to use isolation to improve ESD, EFT, and Surge immunity in industrial systems application report](#)
- Texas Instruments, [MSP430G2132 Mixed Signal Microcontroller data sheet](#)
- Texas Instruments, [REF50xx Low-Noise, Very Low Drift, Precision Voltage Reference data sheet](#)
- Texas Instruments, [SN6501 Transformer Driver for Isolated Power Supplies data sheet](#)
- Texas Instruments, [SN6505A Low-Noise 1-A Transformer Drivers for Isolated Power Supplies data sheet](#)
- Texas Instruments, [TLV707, TLV707P 200-mA, Low-IQ, Low-Noise, Low-Dropout Regulator for Portable Devices data sheet](#)

### 13.2 Related Links

The table below lists quick access links. Categories include technical documents, support and community resources, tools and software, and quick access to sample or buy.

**Table 4. Related Links**

PARTS	PRODUCT FOLDER	ORDER NOW	TECHNICAL DOCUMENTS	TOOLS & SOFTWARE	SUPPORT & COMMUNITY
ISO7740	<a href="#">Click here</a>	<a href="#">Click here</a>	<a href="#">Click here</a>	<a href="#">Click here</a>	<a href="#">Click here</a>
ISO7741	<a href="#">Click here</a>	<a href="#">Click here</a>	<a href="#">Click here</a>	<a href="#">Click here</a>	<a href="#">Click here</a>
ISO7742	<a href="#">Click here</a>	<a href="#">Click here</a>	<a href="#">Click here</a>	<a href="#">Click here</a>	<a href="#">Click here</a>

### 13.3 Receiving Notification of Documentation Updates

To receive notification of documentation updates, navigate to the device product folder on ti.com. In the upper right corner, click on *Alert me* to register and receive a weekly digest of any product information that has changed. For change details, review the revision history included in any revised document.

### 13.4 Community Resources

TI E2E™ [support forums](#) are an engineer's go-to source for fast, verified answers and design help — straight from the experts. Search existing answers or ask your own question to get the quick design help you need.

Linked content is provided "AS IS" by the respective contributors. They do not constitute TI specifications and do not necessarily reflect TI's views; see TI's [Terms of Use](#).

### 13.5 Trademarks

E2E is a trademark of Texas Instruments.

All other trademarks are the property of their respective owners.

### 13.6 Electrostatic Discharge Caution



This integrated circuit can be damaged by ESD. Texas Instruments recommends that all integrated circuits be handled with appropriate precautions. Failure to observe proper handling and installation procedures can cause damage.

ESD damage can range from subtle performance degradation to complete device failure. Precision integrated circuits may be more susceptible to damage because very small parametric changes could cause the device not to meet its published specifications.

## 13.7 Glossary

[SLYZ022](#) — *TI Glossary*.

This glossary lists and explains terms, acronyms, and definitions.

## 14 Mechanical, Packaging, and Orderable Information

The following pages include mechanical packaging and orderable information. This information is the most current data available for the designated devices. This data is subject to change without notice and revision of this document. For browser-based versions of this data sheet, refer to the left-hand navigation.

**PACKAGING INFORMATION**

Orderable Device	Status (1)	Package Type	Package Drawing	Pins	Package Qty	Eco Plan (2)	Lead finish/ Ball material (6)	MSL Peak Temp (3)	Op Temp (°C)	Device Marking (4/5)	Samples
ISO7740DBQ	ACTIVE	SSOP	DBQ	16	75	RoHS & Green	NIPDAU	Level-2-260C-1 YEAR	-55 to 125	7740	<a href="#">Samples</a>
ISO7740DBQR	ACTIVE	SSOP	DBQ	16	2500	RoHS & Green	NIPDAU	Level-2-260C-1 YEAR	-55 to 125	7740	<a href="#">Samples</a>
ISO7740DW	ACTIVE	SOIC	DW	16	40	RoHS & Green	NIPDAU	Level-2-260C-1 YEAR	-55 to 125	ISO7740	<a href="#">Samples</a>
ISO7740DWR	ACTIVE	SOIC	DW	16	2000	RoHS & Green	NIPDAU	Level-2-260C-1 YEAR	-55 to 125	ISO7740	<a href="#">Samples</a>
ISO7740FDBQ	ACTIVE	SSOP	DBQ	16	75	RoHS & Green	NIPDAU	Level-2-260C-1 YEAR	-55 to 125	7740F	<a href="#">Samples</a>
ISO7740FDBQR	ACTIVE	SSOP	DBQ	16	2500	RoHS & Green	NIPDAU	Level-2-260C-1 YEAR	-55 to 125	7740F	<a href="#">Samples</a>
ISO7740FDW	ACTIVE	SOIC	DW	16	40	RoHS & Green	NIPDAU	Level-2-260C-1 YEAR	-55 to 125	ISO7740F	<a href="#">Samples</a>
ISO7740FDWR	ACTIVE	SOIC	DW	16	2000	RoHS & Green	NIPDAU	Level-2-260C-1 YEAR	-55 to 125	ISO7740F	<a href="#">Samples</a>
ISO7741BDW	ACTIVE	SOIC	DW	16	40	RoHS & Green	NIPDAU	Level-2-260C-1 YEAR	-55 to 125	ISO7741B	<a href="#">Samples</a>
ISO7741BDWR	ACTIVE	SOIC	DW	16	2000	RoHS & Green	NIPDAU	Level-2-260C-1 YEAR	-55 to 125	ISO7741B	<a href="#">Samples</a>
ISO7741DBQ	ACTIVE	SSOP	DBQ	16	75	RoHS & Green	NIPDAU	Level-2-260C-1 YEAR	-55 to 125	7741	<a href="#">Samples</a>
ISO7741DBQR	ACTIVE	SSOP	DBQ	16	2500	RoHS & Green	NIPDAU	Level-2-260C-1 YEAR	-55 to 125	7741	<a href="#">Samples</a>
ISO7741DW	ACTIVE	SOIC	DW	16	40	RoHS & Green	NIPDAU	Level-2-260C-1 YEAR	-55 to 125	ISO7741	<a href="#">Samples</a>
ISO7741DWR	ACTIVE	SOIC	DW	16	2000	RoHS & Green	NIPDAU	Level-2-260C-1 YEAR	-55 to 125	ISO7741	<a href="#">Samples</a>
ISO7741FBDW	ACTIVE	SOIC	DW	16	40	RoHS & Green	NIPDAU	Level-2-260C-1 YEAR	-55 to 125	(ISO7731FB, ISO7741FB)	<a href="#">Samples</a>
ISO7741FBDWR	ACTIVE	SOIC	DW	16	2000	RoHS & Green	NIPDAU	Level-2-260C-1 YEAR	-55 to 125	ISO7741FB	<a href="#">Samples</a>
ISO7741FDBQ	ACTIVE	SSOP	DBQ	16	75	RoHS & Green	NIPDAU	Level-2-260C-1 YEAR	-55 to 125	7741F	<a href="#">Samples</a>
ISO7741FDBQR	ACTIVE	SSOP	DBQ	16	2500	RoHS & Green	NIPDAU	Level-2-260C-1 YEAR	-55 to 125	7741F	<a href="#">Samples</a>
ISO7741FDW	ACTIVE	SOIC	DW	16	40	RoHS & Green	NIPDAU	Level-2-260C-1 YEAR	-55 to 125	ISO7741F	<a href="#">Samples</a>
ISO7741FDWR	ACTIVE	SOIC	DW	16	2000	RoHS & Green	NIPDAU	Level-2-260C-1 YEAR	-55 to 125	ISO7741F	<a href="#">Samples</a>

Orderable Device	Status (1)	Package Type	Package Drawing	Pins	Package Qty	Eco Plan (2)	Lead finish/ Ball material (6)	MSL Peak Temp (3)	Op Temp (°C)	Device Marking (4/5)	Samples
ISO7742DBQ	ACTIVE	SSOP	DBQ	16	75	RoHS & Green	NIPDAU	Level-2-260C-1 YEAR	-55 to 125	7742	<a href="#">Samples</a>
ISO7742DBQR	ACTIVE	SSOP	DBQ	16	2500	RoHS & Green	NIPDAU	Level-2-260C-1 YEAR	-55 to 125	7742	<a href="#">Samples</a>
ISO7742DW	ACTIVE	SOIC	DW	16	40	RoHS & Green	NIPDAU	Level-2-260C-1 YEAR	-55 to 125	ISO7742	<a href="#">Samples</a>
ISO7742DWR	ACTIVE	SOIC	DW	16	2000	RoHS & Green	NIPDAU	Level-2-260C-1 YEAR	-55 to 125	ISO7742	<a href="#">Samples</a>
ISO7742FDBQ	ACTIVE	SSOP	DBQ	16	75	RoHS & Green	NIPDAU	Level-2-260C-1 YEAR	-55 to 125	7742F	<a href="#">Samples</a>
ISO7742FDBQR	ACTIVE	SSOP	DBQ	16	2500	RoHS & Green	NIPDAU	Level-2-260C-1 YEAR	-55 to 125	7742F	<a href="#">Samples</a>
ISO7742FDW	ACTIVE	SOIC	DW	16	40	RoHS & Green	NIPDAU	Level-2-260C-1 YEAR	-55 to 125	ISO7742F	<a href="#">Samples</a>
ISO7742FDWR	ACTIVE	SOIC	DW	16	2000	RoHS & Green	NIPDAU	Level-2-260C-1 YEAR	-55 to 125	ISO7742F	<a href="#">Samples</a>

(1) The marketing status values are defined as follows:

**ACTIVE:** Product device recommended for new designs.

**LIFEBUY:** TI has announced that the device will be discontinued, and a lifetime-buy period is in effect.

**NRND:** Not recommended for new designs. Device is in production to support existing customers, but TI does not recommend using this part in a new design.

**PREVIEW:** Device has been announced but is not in production. Samples may or may not be available.

**OBsolete:** TI has discontinued the production of the device.

(2) **RoHS:** TI defines "RoHS" to mean semiconductor products that are compliant with the current EU RoHS requirements for all 10 RoHS substances, including the requirement that RoHS substance do not exceed 0.1% by weight in homogeneous materials. Where designed to be soldered at high temperatures, "RoHS" products are suitable for use in specified lead-free processes. TI may reference these types of products as "Pb-Free".

**RoHS Exempt:** TI defines "RoHS Exempt" to mean products that contain lead but are compliant with EU RoHS pursuant to a specific EU RoHS exemption.

**Green:** TI defines "Green" to mean the content of Chlorine (Cl) and Bromine (Br) based flame retardants meet JS709B low halogen requirements of <=1000ppm threshold. Antimony trioxide based flame retardants must also meet the <=1000ppm threshold requirement.

(3) MSL, Peak Temp. - The Moisture Sensitivity Level rating according to the JEDEC industry standard classifications, and peak solder temperature.

(4) There may be additional marking, which relates to the logo, the lot trace code information, or the environmental category on the device.

(5) Multiple Device Markings will be inside parentheses. Only one Device Marking contained in parentheses and separated by a "~" will appear on a device. If a line is indented then it is a continuation of the previous line and the two combined represent the entire Device Marking for that device.

<sup>(6)</sup> Lead finish/Ball material - Orderable Devices may have multiple material finish options. Finish options are separated by a vertical ruled line. Lead finish/Ball material values may wrap to two lines if the finish value exceeds the maximum column width.

**Important Information and Disclaimer:**The information provided on this page represents TI's knowledge and belief as of the date that it is provided. TI bases its knowledge and belief on information provided by third parties, and makes no representation or warranty as to the accuracy of such information. Efforts are underway to better integrate information from third parties. TI has taken and continues to take reasonable steps to provide representative and accurate information but may not have conducted destructive testing or chemical analysis on incoming materials and chemicals. TI and TI suppliers consider certain information to be proprietary, and thus CAS numbers and other limited information may not be available for release.

In no event shall TI's liability arising out of such information exceed the total purchase price of the TI part(s) at issue in this document sold by TI to Customer on an annual basis.

**OTHER QUALIFIED VERSIONS OF ISO7740, ISO7741, ISO7742 :**

- Automotive : [ISO7740-Q1](#), [ISO7741-Q1](#), [ISO7742-Q1](#)

NOTE: Qualified Version Definitions:

- Automotive - Q100 devices qualified for high-reliability automotive applications targeting zero defects

## TAPE AND REEL INFORMATION



### QUADRANT ASSIGNMENTS FOR PIN 1 ORIENTATION IN TAPE



\*All dimensions are nominal

Device	Package Type	Package Drawing	Pins	SPQ	Reel Diameter (mm)	Reel Width W1 (mm)	A0 (mm)	B0 (mm)	K0 (mm)	P1 (mm)	W (mm)	Pin1 Quadrant
ISO7740DBQR	SSOP	DBQ	16	2500	330.0	12.4	6.4	5.2	2.1	8.0	12.0	Q1
ISO7740DWR	SOIC	DW	16	2000	330.0	16.4	10.75	10.7	2.7	12.0	16.0	Q1
ISO7740DWR	SOIC	DW	16	2000	330.0	16.4	10.75	10.7	2.7	12.0	16.0	Q1
ISO7740FDBQR	SSOP	DBQ	16	2500	330.0	12.4	6.4	5.2	2.1	8.0	12.0	Q1
ISO7740FDWR	SOIC	DW	16	2000	330.0	16.4	10.75	10.7	2.7	12.0	16.0	Q1
ISO7740FDWR	SOIC	DW	16	2000	330.0	16.4	10.75	10.7	2.7	12.0	16.0	Q1
ISO7741BDWR	SOIC	DW	16	2000	330.0	16.4	10.75	10.7	2.7	12.0	16.0	Q1
ISO7741BDWR	SOIC	DW	16	2000	330.0	16.4	10.75	10.7	2.7	12.0	16.0	Q1
ISO7741DBQR	SSOP	DBQ	16	2500	330.0	12.4	6.4	5.2	2.1	8.0	12.0	Q1
ISO7741DWR	SOIC	DW	16	2000	330.0	16.4	10.75	10.7	2.7	12.0	16.0	Q1
ISO7741DWR	SOIC	DW	16	2000	330.0	16.4	10.75	10.7	2.7	12.0	16.0	Q1
ISO7741FBDWR	SOIC	DW	16	2000	330.0	16.4	10.75	10.7	2.7	12.0	16.0	Q1
ISO7741FBDWR	SOIC	DW	16	2000	330.0	16.4	10.75	10.7	2.7	12.0	16.0	Q1
ISO7741FDBQR	SSOP	DBQ	16	2500	330.0	12.4	6.4	5.2	2.1	8.0	12.0	Q1
ISO7741FDWR	SOIC	DW	16	2000	330.0	16.4	10.75	10.7	2.7	12.0	16.0	Q1
ISO7741FDWR	SOIC	DW	16	2000	330.0	16.4	10.75	10.7	2.7	12.0	16.0	Q1
ISO7742DBQR	SSOP	DBQ	16	2500	330.0	12.4	6.4	5.2	2.1	8.0	12.0	Q1
ISO7742DWR	SOIC	DW	16	2000	330.0	16.4	10.75	10.7	2.7	12.0	16.0	Q1

Device	Package Type	Package Drawing	Pins	SPQ	Reel Diameter (mm)	Reel Width W1 (mm)	A0 (mm)	B0 (mm)	K0 (mm)	P1 (mm)	W (mm)	Pin1 Quadrant
ISO7742DWR	SOIC	DW	16	2000	330.0	16.4	10.75	10.7	2.7	12.0	16.0	Q1
ISO7742FDBQR	SSOP	DBQ	16	2500	330.0	12.4	6.4	5.2	2.1	8.0	12.0	Q1
ISO7742FDWR	SOIC	DW	16	2000	330.0	16.4	10.75	10.7	2.7	12.0	16.0	Q1
ISO7742FDWR	SOIC	DW	16	2000	330.0	16.4	10.75	10.7	2.7	12.0	16.0	Q1

## TAPE AND REEL BOX DIMENSIONS

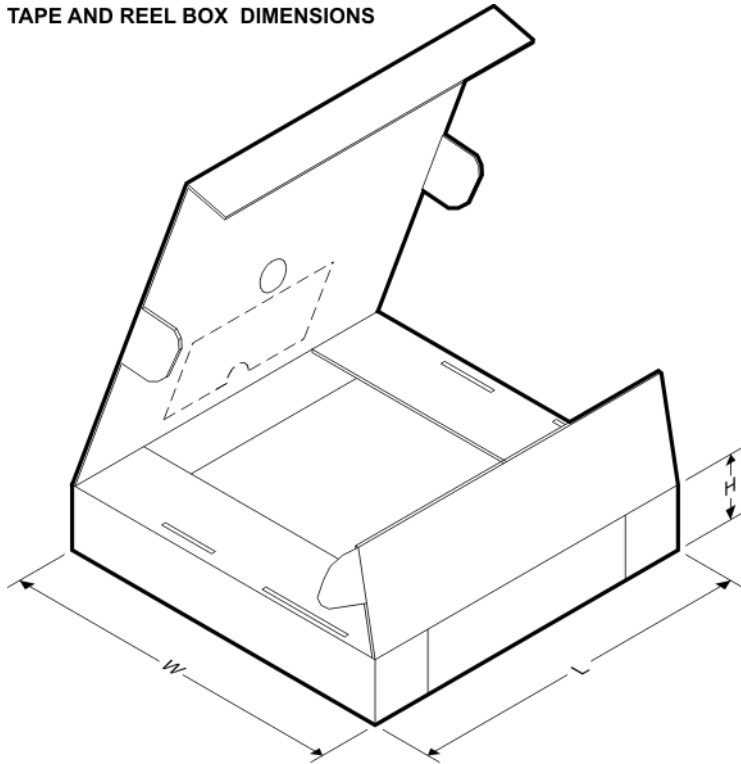

\*All dimensions are nominal

Device	Package Type	Package Drawing	Pins	SPQ	Length (mm)	Width (mm)	Height (mm)
ISO7740DBQR	SSOP	DBQ	16	2500	350.0	350.0	43.0
ISO7740DWR	SOIC	DW	16	2000	853.0	449.0	35.0
ISO7740DWR	SOIC	DW	16	2000	350.0	350.0	43.0
ISO7740FDBQR	SSOP	DBQ	16	2500	350.0	350.0	43.0
ISO7740FDWR	SOIC	DW	16	2000	350.0	350.0	43.0
ISO7740FDWR	SOIC	DW	16	2000	853.0	449.0	35.0
ISO7741BDWR	SOIC	DW	16	2000	367.0	367.0	38.0
ISO7741BDWR	SOIC	DW	16	2000	350.0	350.0	43.0
ISO7741DBQR	SSOP	DBQ	16	2500	350.0	350.0	43.0
ISO7741DWR	SOIC	DW	16	2000	853.0	449.0	35.0
ISO7741DWR	SOIC	DW	16	2000	350.0	350.0	43.0
ISO7741FBDWR	SOIC	DW	16	2000	853.0	449.0	35.0
ISO7741FBDWR	SOIC	DW	16	2000	350.0	350.0	43.0

Device	Package Type	Package Drawing	Pins	SPQ	Length (mm)	Width (mm)	Height (mm)
ISO7741FDBQR	SSOP	DBQ	16	2500	350.0	350.0	43.0
ISO7741FDWR	SOIC	DW	16	2000	853.0	449.0	35.0
ISO7741FDWR	SOIC	DW	16	2000	350.0	350.0	43.0
ISO7742DBQR	SSOP	DBQ	16	2500	350.0	350.0	43.0
ISO7742DWR	SOIC	DW	16	2000	350.0	350.0	43.0
ISO7742DWR	SOIC	DW	16	2000	853.0	449.0	35.0
ISO7742FDBQR	SSOP	DBQ	16	2500	350.0	350.0	43.0
ISO7742FDWR	SOIC	DW	16	2000	367.0	367.0	38.0
ISO7742FDWR	SOIC	DW	16	2000	350.0	350.0	43.0

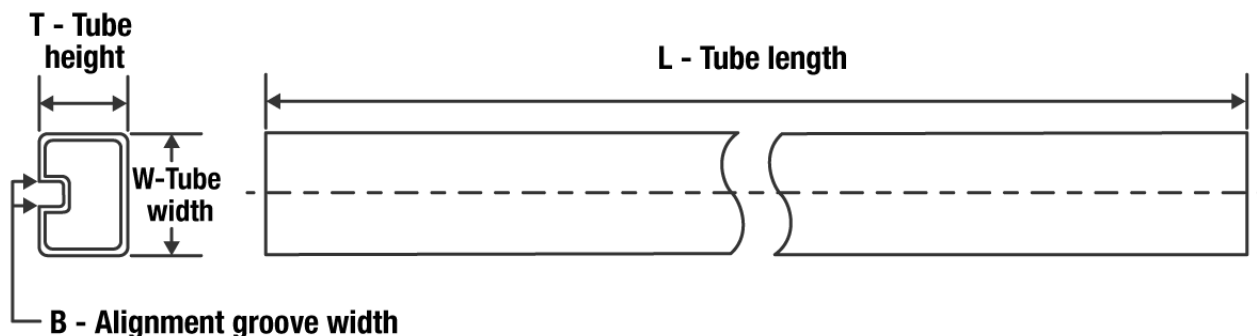
**TUBE**

\*All dimensions are nominal

Device	Package Name	Package Type	Pins	SPQ	L (mm)	W (mm)	T (μm)	B (mm)
ISO7740DBQ	DBQ	SSOP	16	75	505.46	6.76	3810	4
ISO7740DW	DW	SOIC	16	40	507	12.83	5080	6.6
ISO7740DW	DW	SOIC	16	40	506.98	12.7	4826	6.6
ISO7740FDBQ	DBQ	SSOP	16	75	505.46	6.76	3810	4
ISO7740FDW	DW	SOIC	16	40	507	12.83	5080	6.6
ISO7740FDW	DW	SOIC	16	40	506.98	12.7	4826	6.6
ISO7741BDW	DW	SOIC	16	40	506.98	12.7	4826	6.6
ISO7741BDW	DW	SOIC	16	40	507	12.83	5080	6.6
ISO7741DBQ	DBQ	SSOP	16	75	505.46	6.76	3810	4
ISO7741DW	DW	SOIC	16	40	507	12.83	5080	6.6
ISO7741DW	DW	SOIC	16	40	506.98	12.7	4826	6.6
ISO7741FBDW	DW	SOIC	16	40	506.98	12.7	4826	6.6
ISO7741FBDW	DW	SOIC	16	40	507	12.83	5080	6.6
ISO7741FDBQ	DBQ	SSOP	16	75	505.46	6.76	3810	4
ISO7741FDW	DW	SOIC	16	40	507	12.83	5080	6.6
ISO7741FDW	DW	SOIC	16	40	506.98	12.7	4826	6.6
ISO7742DBQ	DBQ	SSOP	16	75	505.46	6.76	3810	4
ISO7742DW	DW	SOIC	16	40	507	12.83	5080	6.6
ISO7742DW	DW	SOIC	16	40	506.98	12.7	4826	6.6
ISO7742FDBQ	DBQ	SSOP	16	75	505.46	6.76	3810	4
ISO7742FDW	DW	SOIC	16	40	507	12.83	5080	6.6
ISO7742FDW	DW	SOIC	16	40	506.98	12.7	4826	6.6

## GENERIC PACKAGE VIEW

**DW 16**

**SOIC - 2.65 mm max height**

7.5 x 10.3, 1.27 mm pitch

SMALL OUTLINE INTEGRATED CIRCUIT

This image is a representation of the package family, actual package may vary.  
Refer to the product data sheet for package details.

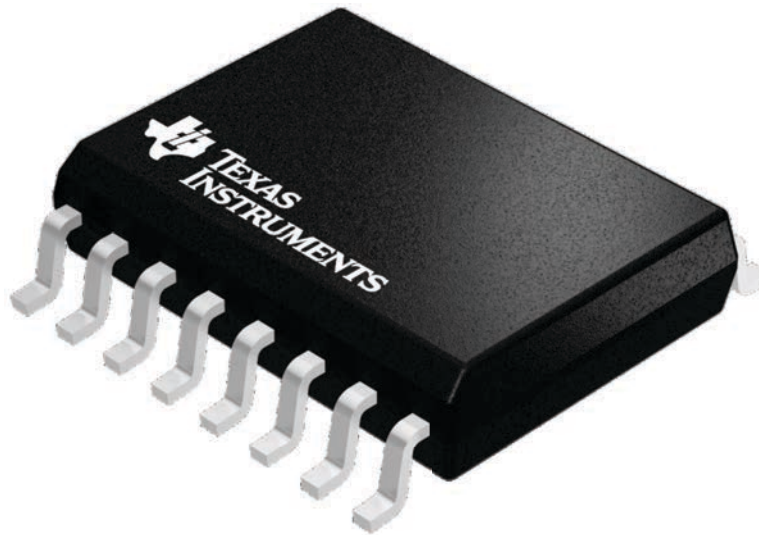

4224780/A

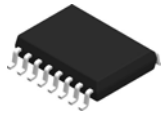

# DW0016A

# PACKAGE OUTLINE SOIC - 2.65 mm max height

SOIC

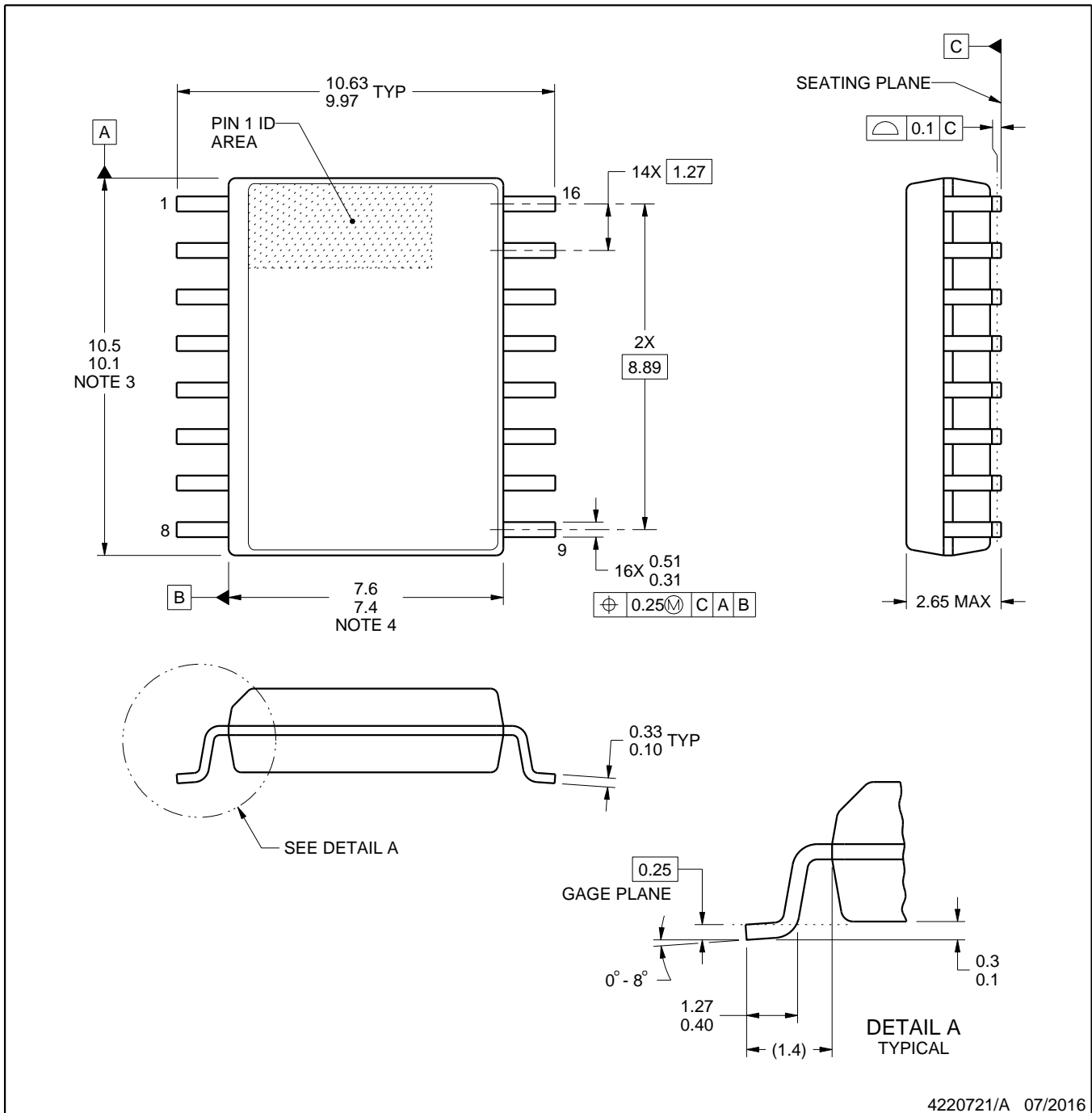

4220721/A 07/2016

### NOTES:

1. All linear dimensions are in millimeters. Dimensions in parenthesis are for reference only. Dimensioning and tolerancing per ASME Y14.5M.
2. This drawing is subject to change without notice.
3. This dimension does not include mold flash, protrusions, or gate burrs. Mold flash, protrusions, or gate burrs shall not exceed 0.15 mm, per side.
4. This dimension does not include interlead flash. Interlead flash shall not exceed 0.25 mm, per side.
5. Reference JEDEC registration MS-013.

# EXAMPLE BOARD LAYOUT

DW0016A

SOIC - 2.65 mm max height

SOIC

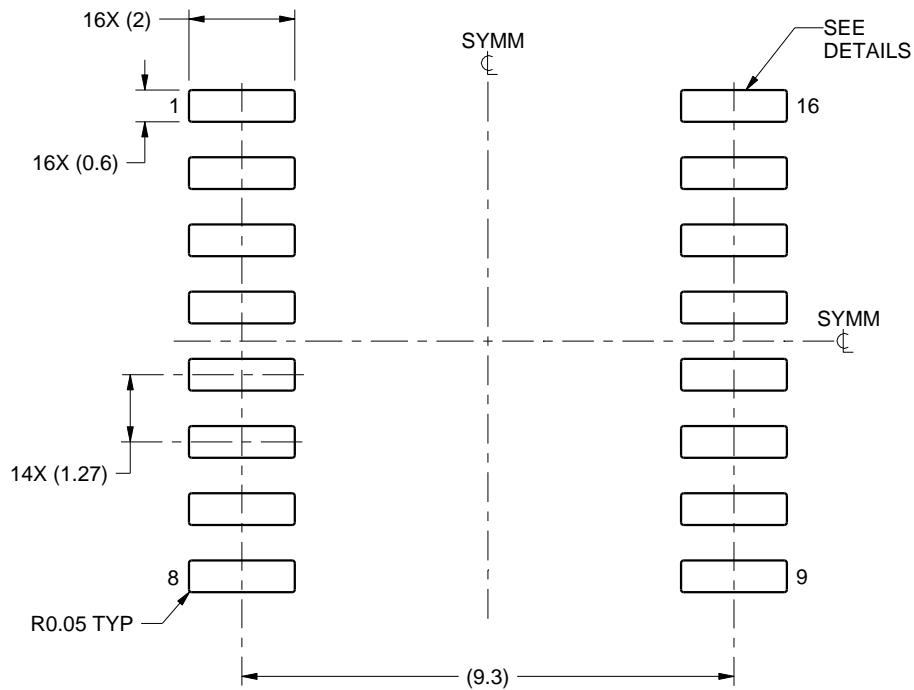

LAND PATTERN EXAMPLE  
SCALE:7X

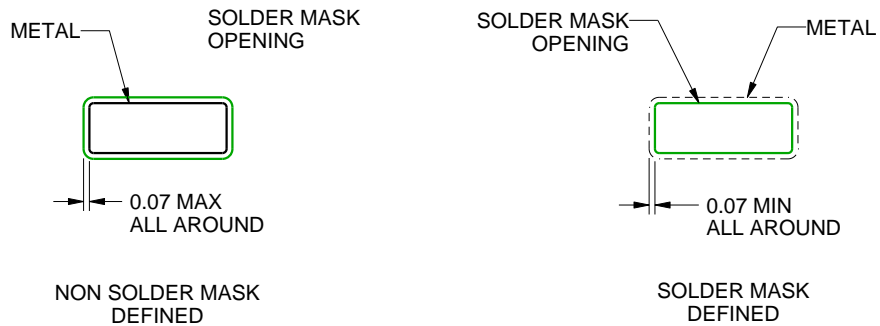

SOLDER MASK DETAILS

4220721/A 07/2016

NOTES: (continued)

6. Publication IPC-7351 may have alternate designs.

7. Solder mask tolerances between and around signal pads can vary based on board fabrication site.

# EXAMPLE STENCIL DESIGN

DW0016A

SOIC - 2.65 mm max height

SOIC

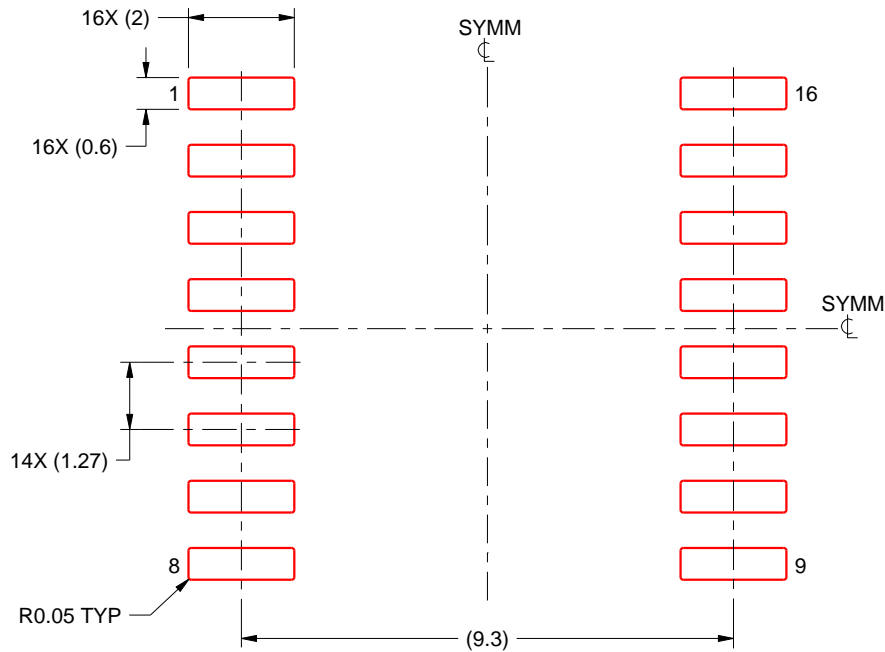

SOLDER PASTE EXAMPLE  
BASED ON 0.125 mm THICK STENCIL  
SCALE:7X

4220721/A 07/2016

NOTES: (continued)

8. Laser cutting apertures with trapezoidal walls and rounded corners may offer better paste release. IPC-7525 may have alternate design recommendations.
9. Board assembly site may have different recommendations for stencil design.

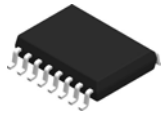

# DW0016B

# PACKAGE OUTLINE

SOIC - 2.65 mm max height

SOIC

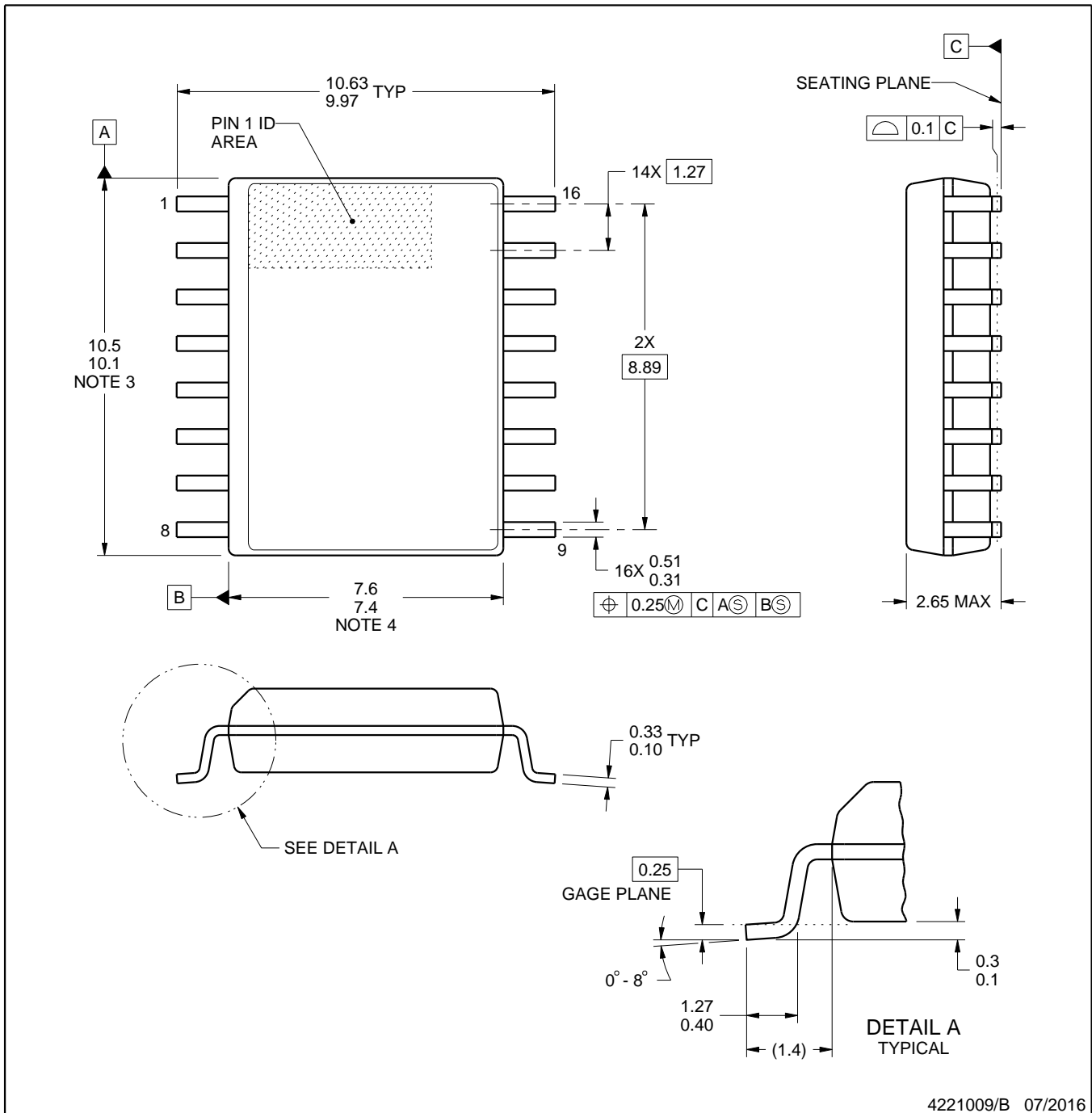

4221009/B 07/2016

### NOTES:

1. All linear dimensions are in millimeters. Dimensions in parenthesis are for reference only. Dimensioning and tolerancing per ASME Y14.5M.
2. This drawing is subject to change without notice.
3. This dimension does not include mold flash, protrusions, or gate burrs. Mold flash, protrusions, or gate burrs shall not exceed 0.15 mm, per side.
4. This dimension does not include interlead flash. Interlead flash shall not exceed 0.25 mm, per side.
5. Reference JEDEC registration MS-013.

# EXAMPLE BOARD LAYOUT

DW0016B

SOIC - 2.65 mm max height

SOIC

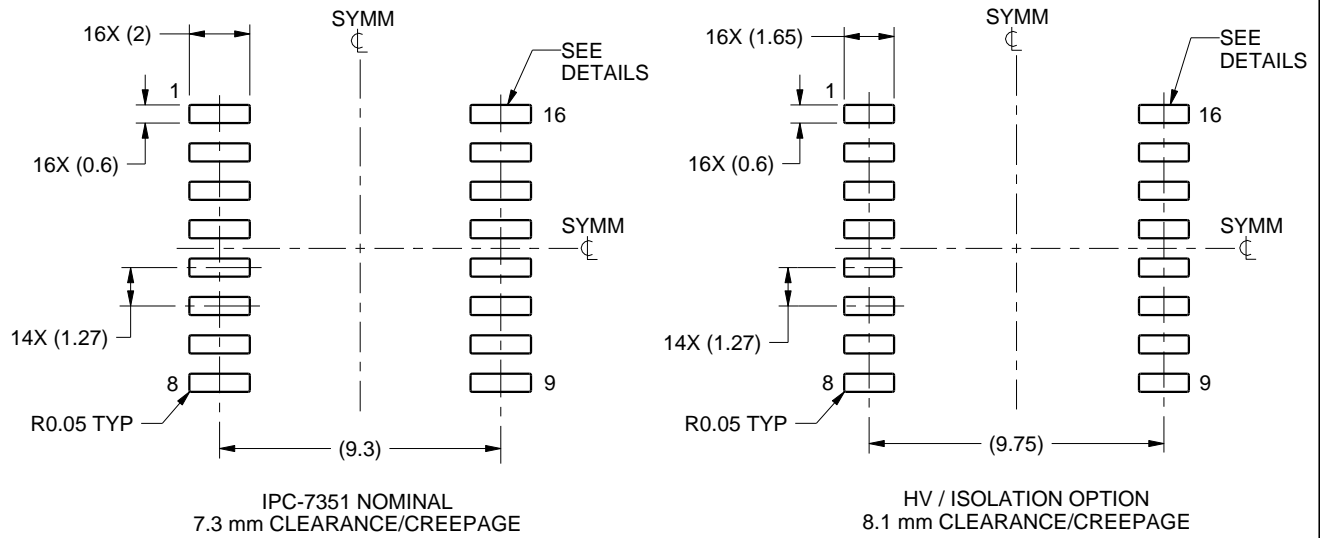

LAND PATTERN EXAMPLE  
SCALE:4X

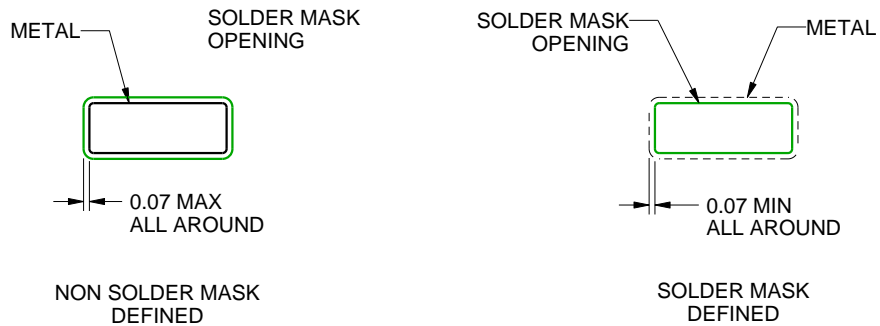

SOLDER MASK DETAILS

4221009/B 07/2016

NOTES: (continued)

- 6. Publication IPC-7351 may have alternate designs.
- 7. Solder mask tolerances between and around signal pads can vary based on board fabrication site.

# EXAMPLE STENCIL DESIGN

DW0016B

SOIC - 2.65 mm max height

SOIC

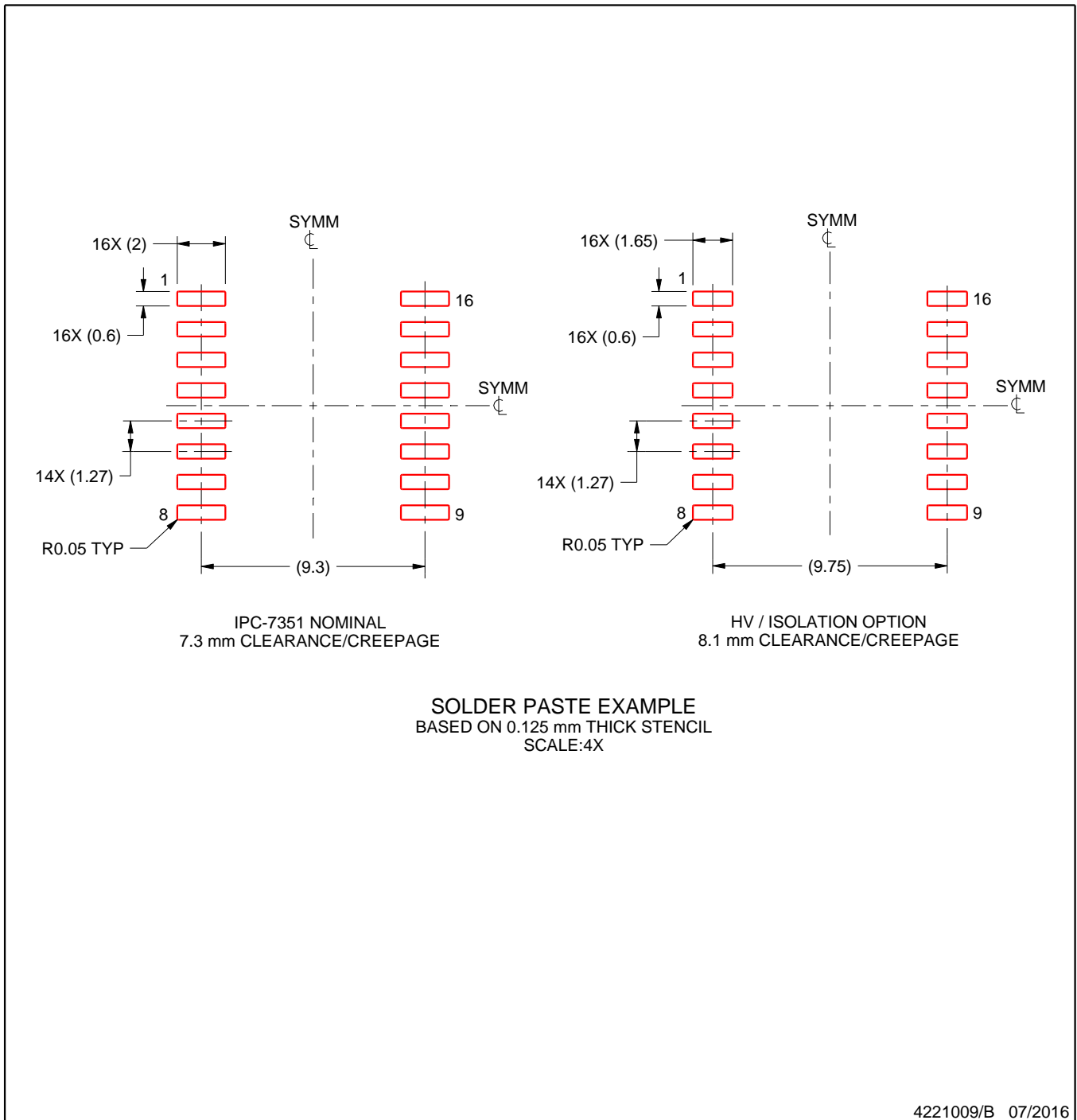

NOTES: (continued)

8. Laser cutting apertures with trapezoidal walls and rounded corners may offer better paste release. IPC-7525 may have alternate design recommendations.
9. Board assembly site may have different recommendations for stencil design.

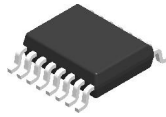

# DBQ0016A

# PACKAGE OUTLINE

## SSOP - 1.75 mm max height

SHRINK SMALL-OUTLINE PACKAGE

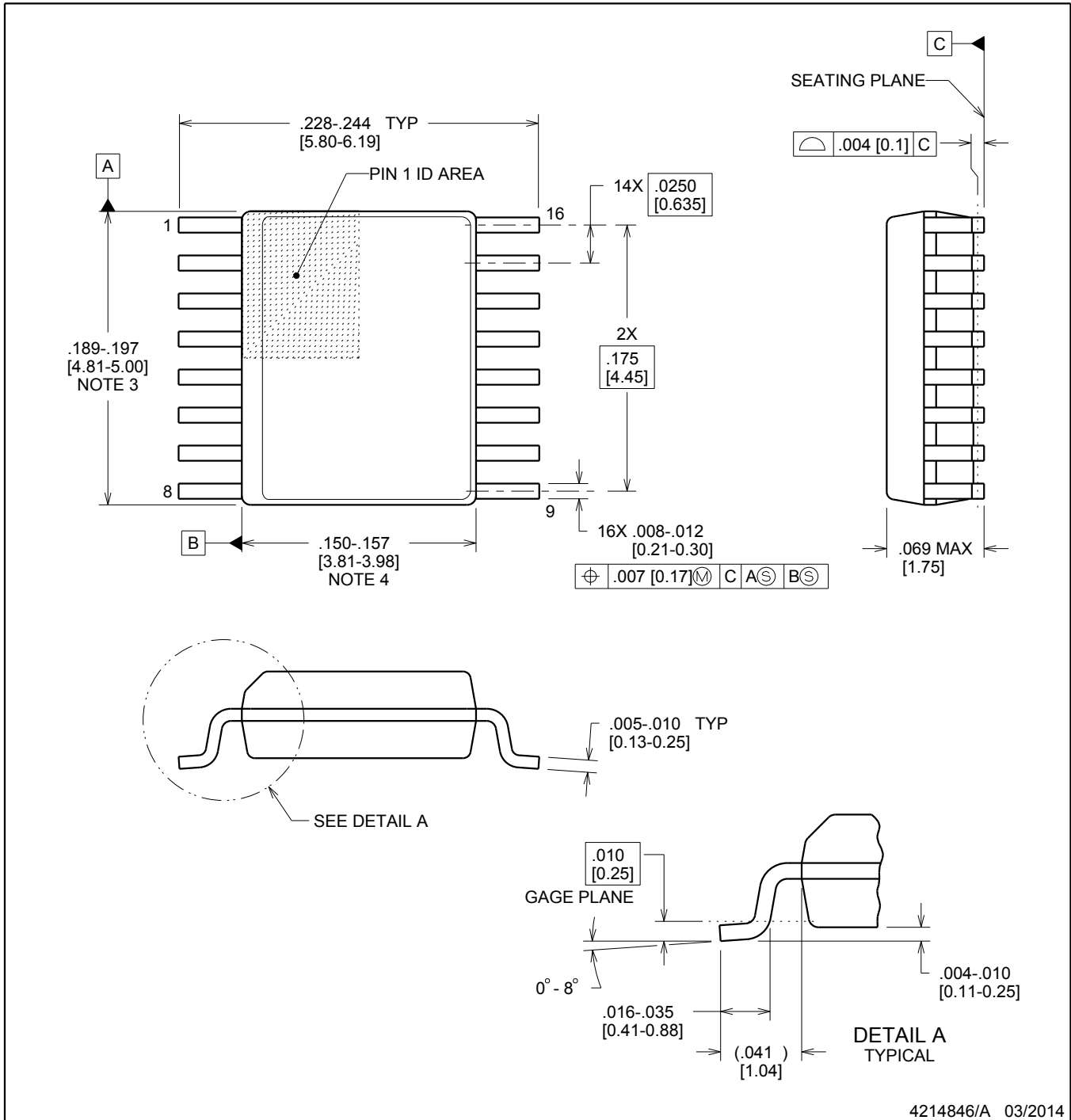

4214846/A 03/2014

### NOTES:

1. Linear dimensions are in inches [millimeters]. Dimensions in parenthesis are for reference only. Controlling dimensions are in inches. Dimensioning and tolerancing per ASME Y14.5M.
2. This drawing is subject to change without notice.
3. This dimension does not include mold flash, protrusions, or gate burrs. Mold flash, protrusions, or gate burrs shall not exceed .006 inch, per side.
4. This dimension does not include interlead flash.
5. Reference JEDEC registration MO-137, variation AB.

# EXAMPLE BOARD LAYOUT

DBQ0016A

SSOP - 1.75 mm max height

SHRINK SMALL-OUTLINE PACKAGE

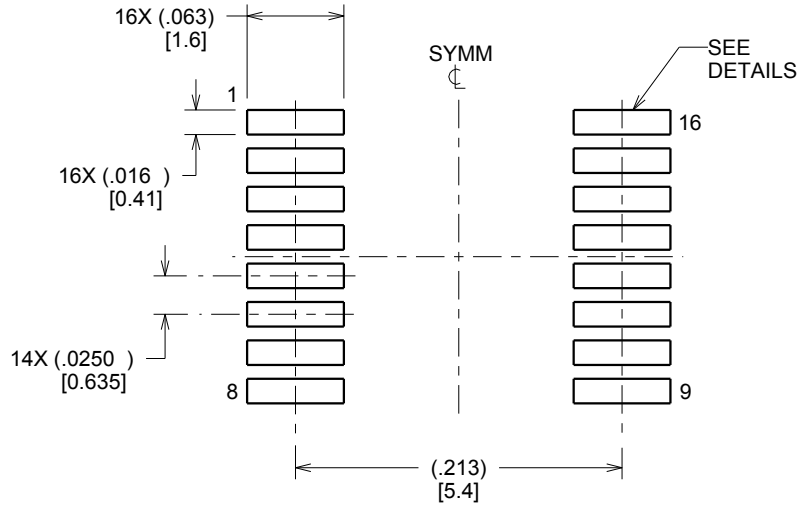

LAND PATTERN EXAMPLE  
SCALE:8X

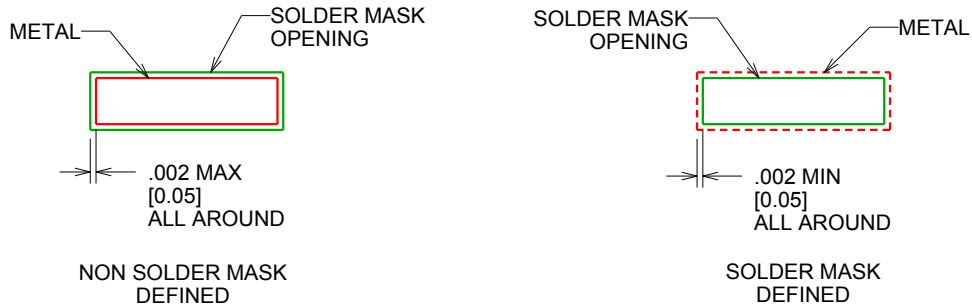

SOLDER MASK DETAILS

4214846/A 03/2014

NOTES: (continued)

- 6. Publication IPC-7351 may have alternate designs.
- 7. Solder mask tolerances between and around signal pads can vary based on board fabrication site.

# EXAMPLE STENCIL DESIGN

DBQ0016A

SSOP - 1.75 mm max height

SHRINK SMALL-OUTLINE PACKAGE

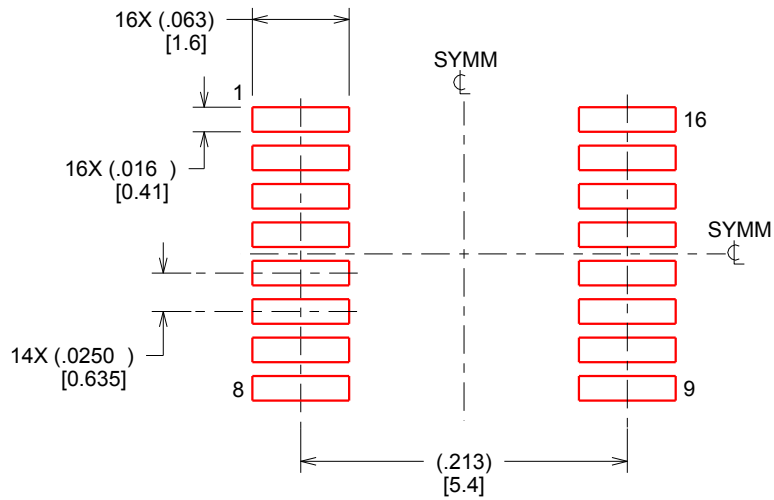

SOLDER PASTE EXAMPLE  
BASED ON .005 INCH [0.127 MM] THICK STENCIL  
SCALE:8X

4214846/A 03/2014

NOTES: (continued)

8. Laser cutting apertures with trapezoidal walls and rounded corners may offer better paste release. IPC-7525 may have alternate design recommendations.
9. Board assembly site may have different recommendations for stencil design.

## IMPORTANT NOTICE AND DISCLAIMER

TI PROVIDES TECHNICAL AND RELIABILITY DATA (INCLUDING DATA SHEETS), DESIGN RESOURCES (INCLUDING REFERENCE DESIGNS), APPLICATION OR OTHER DESIGN ADVICE, WEB TOOLS, SAFETY INFORMATION, AND OTHER RESOURCES "AS IS" AND WITH ALL FAULTS, AND DISCLAIMS ALL WARRANTIES, EXPRESS AND IMPLIED, INCLUDING WITHOUT LIMITATION ANY IMPLIED WARRANTIES OF MERCHANTABILITY, FITNESS FOR A PARTICULAR PURPOSE OR NON-INFRINGEMENT OF THIRD PARTY INTELLECTUAL PROPERTY RIGHTS.

These resources are intended for skilled developers designing with TI products. You are solely responsible for (1) selecting the appropriate TI products for your application, (2) designing, validating and testing your application, and (3) ensuring your application meets applicable standards, and any other safety, security, regulatory or other requirements.

These resources are subject to change without notice. TI grants you permission to use these resources only for development of an application that uses the TI products described in the resource. Other reproduction and display of these resources is prohibited. No license is granted to any other TI intellectual property right or to any third party intellectual property right. TI disclaims responsibility for, and you will fully indemnify TI and its representatives against, any claims, damages, costs, losses, and liabilities arising out of your use of these resources.

TI's products are provided subject to [TI's Terms of Sale](#) or other applicable terms available either on [ti.com](http://ti.com) or provided in conjunction with such TI products. TI's provision of these resources does not expand or otherwise alter TI's applicable warranties or warranty disclaimers for TI products.

TI objects to and rejects any additional or different terms you may have proposed.

Mailing Address: Texas Instruments, Post Office Box 655303, Dallas, Texas 75265  
Copyright © 2022, Texas Instruments Incorporated