

# 具有 65V、1.5A 集成 MOSFET 的 LM25180-Q1 42V<sub>IN</sub> PSR 反激式直流/直流转换器

## 1 特性

- 符合面向汽车 应用的
  - 器件温度等级 1: -40°C 至 125°C 的环境温度范围
- 专为可靠耐用的应用 设计
  - 4.5V 至 42 V
  - 稳定可靠的解决方案, 只有一个组件穿过隔离层
  - ±1.5% 的总输出稳压精度
  - 可选 V<sub>OUT</sub> 温度补偿
  - 6ms 内部或可编程软启动
  - 输入 UVLO 和热关断保护
  - 断续模式过流故障保护
  - 具有 -40°C 至 +150°C 的结温范围
- 通过集成技术减小解决方案尺寸, 降低成本
  - 集成 65V、0.4Ω 功率 MOSFET
  - 无需光耦合器或变压器辅助绕组即可进行 V<sub>OUT</sub> 稳压
  - 低 EMI 运行, 符合 CISPR 25 标准
- 高效率 PSR 反激运行
  - 重负载情况下, 可在边界导电模式 (BCM) 下实现准谐振开关
  - 具有用于提升效率的外部偏置选项
  - 具有单输出和多输出实施手段
- 使用 WEBENCH<sup>®</sup> 电源设计器 创建定制稳压器设计

## 2 应用

- 汽车车身电子设备
- 汽车动力传动系统
- 隔离式偏置电源轨

典型应用

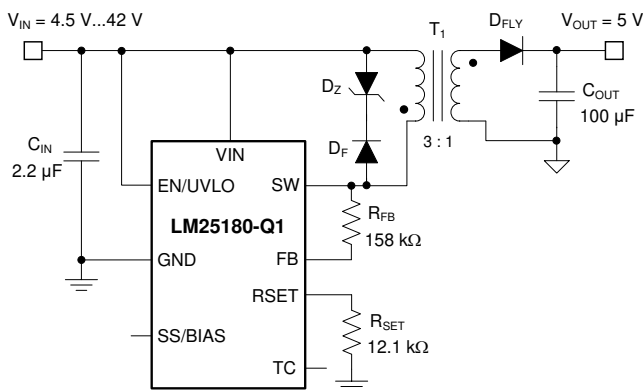

## 3 说明

LM25180-Q1 是一款初级侧稳压 (PSR) 反激式转换器, 在 4.5V 至 42V 的宽输入电压范围内具有高效率。隔离输出电压采样自初级侧反激式电压, 因此, 无需使用光耦合器、电压基准或变压器的第三绕组进行输出电压稳压。凭借高度的集成性, 可实现简单可靠的高密度设计, 其中只有一个组件穿过隔离层。通过采用边界导电模式 (BCM) 开关, 可实现紧凑的磁解决方案以及优于 ±1.5% 的负载和线路调节性能。集成的 65V 功率 MOSFET 能够提供高达 7W 的输出功率并提高应对线路瞬变的余量。

LM25180-Q1 转换器简化了隔离式直流/直流电源的实施, 且可通过可选功能优化目标终端设备的性能。该器件通过一个电阻器来设置输出电压, 同时使用可选的电阻器通过抵消反激式二极管的压降热系数来提高输出电压精度。其他功能包括内部固定或外部可编程软启动、可实现更高效率的可选偏置电源连接、用于可调节线路 UVLO 的精密使能输入 (带迟滞功能)、间断模式过载保护和带自动恢复功能的热关断保护。

LM25180-Q1 符合汽车 AEC-Q100 1 级标准, 并且采用引脚间距为 0.8mm 且具有可湿性侧面的 8 引脚 WSON 封装。

器件信息(1)

器件型号	封装	封装尺寸 (标称值)
LM25180-Q1	WSON (8)	4.00mm × 4.00mm

(1) 如需了解所有可用封装, 请参阅数据表末尾的可订购产品附录。

典型效率 (V<sub>OUT</sub> = 5V)

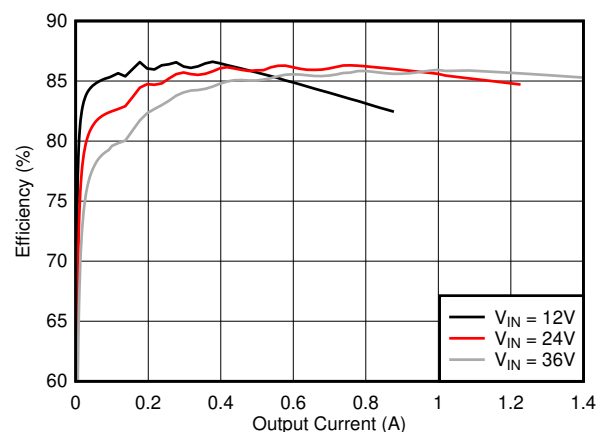

## 目录

<b>1</b>	特性 .....	<b>1</b>	<b>8</b>	<b>Application and Implementation</b> .....	<b>16</b>
<b>2</b>	应用 .....	<b>1</b>	8.1	Application Information.....	16
<b>3</b>	说明 .....	<b>1</b>	8.2	Typical Applications .....	16
<b>4</b>	修订历史记录 .....	<b>2</b>	<b>9</b>	<b>Power Supply Recommendations</b> .....	<b>32</b>
<b>5</b>	<b>Pin Configuration and Functions</b> .....	<b>3</b>	<b>10</b>	<b>Layout</b> .....	<b>33</b>
<b>6</b>	<b>Specifications</b> .....	<b>4</b>	10.1	Layout Guidelines .....	33
6.1	Absolute Maximum Ratings .....	4	10.2	Layout Examples.....	34
6.2	ESD Ratings.....	4	<b>11</b>	<b>器件和文档支持</b> .....	<b>35</b>
6.3	Recommended Operating Conditions.....	4	11.1	器件支持 .....	35
6.4	Thermal Information .....	4	11.2	文档支持 .....	35
6.5	Electrical Characteristics.....	5	11.3	接收文档更新通知 .....	36
6.6	Typical Characteristics .....	6	11.4	社区资源.....	36
<b>7</b>	<b>Detailed Description</b> .....	<b>9</b>	11.5	商标.....	36
7.1	Overview .....	9	11.6	静电放电警告.....	36
7.2	Functional Block Diagram .....	9	11.7	Glossary .....	36
7.3	Feature Description.....	9	<b>12</b>	<b>"机械、封装和可订购信息</b> .....	<b>37</b>
7.4	Device Functional Modes.....	15			

## 4 修订历史记录

注：之前版本的页码可能与当前版本有所不同。

Changes from Original (November 2018) to Revision A	Page
• Changed EC table specs for current limit.....	4
• 已添加 note about failsafe current limit.....	14

## 5 Pin Configuration and Functions

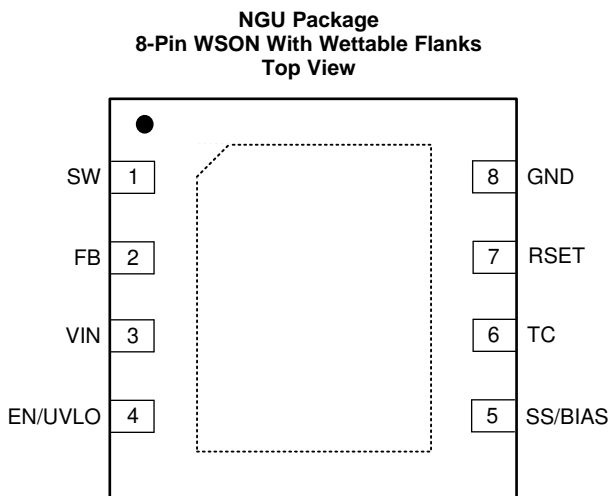

### Pin Functions

PIN		I/O <sup>(1)</sup>	DESCRIPTION
NO.	NAME		
1	SW	P	Switch node that is internally connected to the drain of the N-channel power MOSFET. Connect to the primary-side switching terminal of the flyback transformer.
2	FB	I	Primary side feedback pin. Connect a resistor from FB to SW. The ratio of the FB resistor to the resistor at the RSET pin sets the output voltage.
3	VIN	P/I	Input supply connection. Source for internal bias regulators and input voltage sensing pin. Connect directly to the input supply of the converter with short, low impedance paths.
4	EN/UVLO	I	Enable input and undervoltage lockout (UVLO) programming pin. If the EN/UVLO voltage is below 1.1 V, the converter is in shutdown mode with all functions disabled. If the EN/UVLO voltage is greater than 1.1 V and below 1.5 V, the converter is in standby mode with the internal regulator operational and no switching. If the EN/UVLO voltage is above 1.5 V, the start-up sequence begins.
5	SS/BIAS	I	Soft-start or bias input. Connect a capacitor from SS/BIAS to GND to adjust the output start-up time and input inrush current. If SS/BIAS is left open, the internal 6-ms soft-start timer is activated. Connect an external supply to SS/BIAS to supply bias to the internal voltage regulator and enable internal soft start.
6	TC	I	Temperature compensation pin. Tie a resistor from TC to RSET to compensate for the temperature coefficient of the forward voltage drop of the secondary diode, thus improving regulation at the secondary-side output.
7	RSET	I	Reference resistor tied to GND to set the reference current for FB. Connect a 12.1-kΩ resistor from RSET to GND.
8	GND	G	Analog and power ground. Ground connection of internal control circuits and power MOSFET.
-	DAP	G	Die attach pad. Connect to PCB ground plane.

(1) P = Power, G = Ground, I = Input, O = Output.

## 6 Specifications

### 6.1 Absolute Maximum Ratings

Over the recommended operating junction temperature range of  $-40^{\circ}\text{C}$  to  $150^{\circ}\text{C}$  (unless otherwise noted)

		MIN	MAX	UNIT
Input voltage	VIN to GND	-0.3	45	V
	EN/UVLO to GND	-0.3	45	
	TC to GND	-0.3	6	
	SS/BIAS to GND	-0.3	14	
	FB to GND	-0.3	45.3	
	FB to VIN	-0.3	0.3	
	RSET to GND	-0.3	3	
Output voltage	SW to GND	-1.5	70	V
	SW to GND (20-ns transient)	-3		
Operating junction temperature, $T_J$		-40	150	$^{\circ}\text{C}$
Storage temperature, $T_{\text{stg}}$		-55	150	$^{\circ}\text{C}$

### 6.2 ESD Ratings

			VALUE	UNIT
$V_{\text{(ESD)}}$	Electrostatic discharge	Human body model (HBM), per AEC Q100-002 HBM ESD Classification Level 2 <sup>(1)</sup>	$\pm 2000$	V
		Charged device model (CDM), per AEC Q100-011	$\pm 500$	
		CDM ESD Classification Level C4B	$\pm 750$	

(1) AEC Q100-002 indicates HBM stressing is done in accordance with the ANSI/ESDA/JEDEC JS-001 specification.

### 6.3 Recommended Operating Conditions

Over the recommended operating junction temperature range of  $-40^{\circ}\text{C}$  to  $150^{\circ}\text{C}$  (unless otherwise noted)

		MIN	NOM	MAX	UNIT
$V_{\text{IN}}$	Input voltage after turn on	4.5		42	V
$V_{\text{SW}}$	SW voltage			65	V
$V_{\text{EN/UVLO}}$	EN/UVLO voltage			42	V
$V_{\text{SS/BIAS}}$	SS/BIAS voltage			13	V
$T_J$	Operating junction temperature	-40		150	$^{\circ}\text{C}$

### 6.4 Thermal Information

THERMAL METRIC <sup>(1)</sup>		LM25180-Q1	UNIT
		NGU (WSON)	
		8 PINS	
$R_{\theta\text{JA}}$	Junction-to-ambient thermal resistance	41.3	$^{\circ}\text{C}/\text{W}$
$R_{\theta\text{JC(top)}}$	Junction-to-case (top) thermal resistance	34.7	$^{\circ}\text{C}/\text{W}$
$R_{\theta\text{JB}}$	Junction-to-board thermal resistance	19.1	$^{\circ}\text{C}/\text{W}$
$\Psi_{\text{JT}}$	Junction-to-top characterization parameter	0.3	$^{\circ}\text{C}/\text{W}$
$\Psi_{\text{JB}}$	Junction-to-board characterization parameter	19.2	$^{\circ}\text{C}/\text{W}$
$R_{\theta\text{JC(bot)}}$	Junction-to-case (bottom) thermal resistance	3.2	$^{\circ}\text{C}/\text{W}$

(1) For more information about traditional and new thermal metrics, see the [Semiconductor and IC Package Thermal Metrics](#) application report.

## 6.5 Electrical Characteristics

Typical values correspond to  $T_J = 25^\circ\text{C}$ . Minimum and maximum limits apply over the full  $-40^\circ\text{C}$  to  $150^\circ\text{C}$  junction temperature range unless otherwise indicated.  $V_{IN} = 24\text{ V}$  and  $V_{EN/UVLO} = 2\text{ V}$  unless otherwise stated.

PARAMETER		TEST CONDITIONS	MIN	TYP	MAX	UNIT
<b>SUPPLY CURRENT</b>						
$I_{SHUTDOWN}$	VIN shutdown current	$V_{EN/UVLO} = 0\text{ V}$		3		$\mu\text{A}$
$I_{ACTIVE}$	VIN active current	$V_{EN/UVLO} = 2.5\text{ V}$ , $V_{RSET} = 1.8\text{ V}$		260	350	$\mu\text{A}$
$I_{ACTIVE-BIAS}$	VIN current with BIAS connected	$V_{SS/BIAS} = 6\text{ V}$		25	40	$\mu\text{A}$
$V_{SD-FALLING}$	Shutdown threshold	$V_{EN/UVLO}$ falling	0.3			V
<b>ENABLE AND INPUT UVLO</b>						
$V_{SD-RISING}$	Standby threshold	$V_{EN/UVLO}$ rising		0.8	1	V
$V_{UV-RISING}$	Enable threshold	$V_{EN/UVLO}$ rising	1.45	1.5	1.53	V
$V_{UV-HYST}$	Enable voltage hysteresis	$V_{EN/UVLO}$ falling	0.04	0.05		V
$I_{UV-HYST}$	Enable current hysteresis	$V_{EN/UVLO} = 1.6\text{ V}$	4.2	5	5.5	$\mu\text{A}$
<b>FEEDBACK</b>						
$I_{RSET}$	RSET current	$R_{RSET} = 12.1\text{ k}\Omega$		100		$\mu\text{A}$
$V_{RSET}$	RSET regulation voltage	$R_{RSET} = 12.1\text{ k}\Omega$	1.191	1.21	1.224	V
$V_{FB-VIN1}$	FB to VIN voltage	$I_{FB} = 80\text{ }\mu\text{A}$	-40			mV
$V_{FB-VIN2}$	FB to VIN voltage	$I_{FB} = 120\text{ }\mu\text{A}$			40	mV
<b>SWITCHING FREQUENCY</b>						
$F_{SW-MIN}$	Minimum switching frequency			12		kHz
$F_{SW-MAX}$	Maximum switching frequency			350		kHz
$t_{ON-MIN}$	Minimum switch on-time			140		ns
<b>DIODE THERMAL COMPENSATION</b>						
$V_{TC}$	TC voltage	$I_{TC} = \pm 10\text{ }\mu\text{A}$ , $T_J = 25^\circ\text{C}$		1.2	1.27	V
<b>POWER SWITCHES</b>						
$R_{DS(on)}$	MOSFET on-state resistance	$I_{SW} = 100\text{ mA}$		0.4		$\Omega$
<b>SOFT-START AND BIAS</b>						
$I_{SS}$	SS ext capacitor charging current			5		$\mu\text{A}$
$t_{SS}$	Internal SS time			6		ms
$V_{BIAS-UVLO-RISE}$	BIAS enable voltage	$V_{SS/BIAS}$ rising		5.5	5.75	V
$V_{BIAS-UVLO-HYST}$	BIAS UVLO hysteresis	$V_{SS/BIAS}$ falling		190		mV
<b>CURRENT LIMIT</b>						
$I_{SW-PEAK}$	Peak current limit threshold		1.23	1.5	1.73	A
<b>THERMAL SHUTDOWN</b>						
$T_{SD}$	Thermal shutdown threshold	$T_J$ rising		175		$^\circ\text{C}$
$T_{SD-HYS}$	Thermal shutdown hysteresis			6		$^\circ\text{C}$

### 6.6 Typical Characteristics

$V_{IN} = 24\text{ V}$ ,  $V_{EN/UVLO} = 2\text{ V}$  (unless otherwise stated).

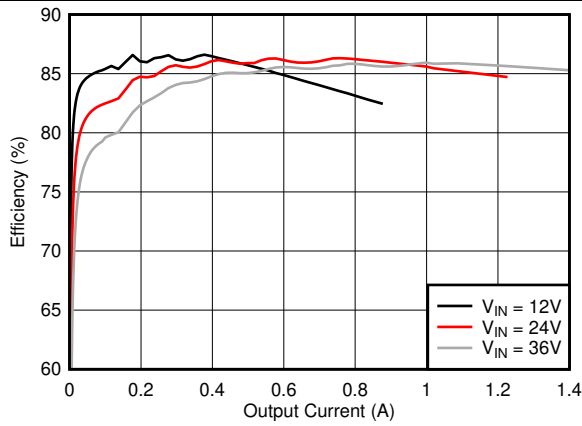

See 图 23

图 1. Efficiency vs. Load

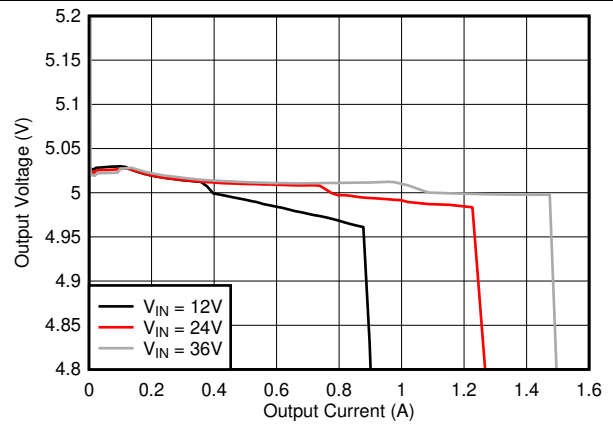

See 图 23

图 2. Output Voltage vs. Load

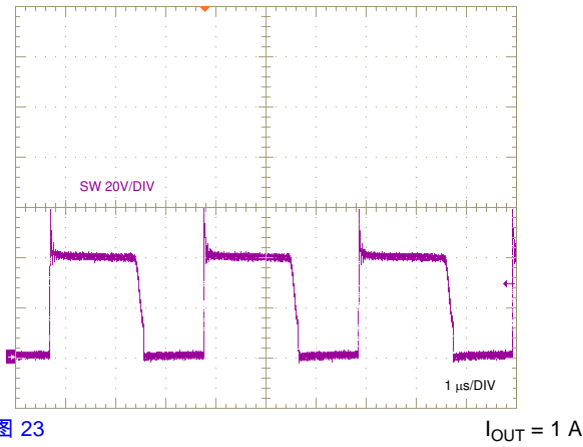

See 图 23

$I_{OUT} = 1\text{ A}$

图 3. Primary-side Switching Waveform in BCM

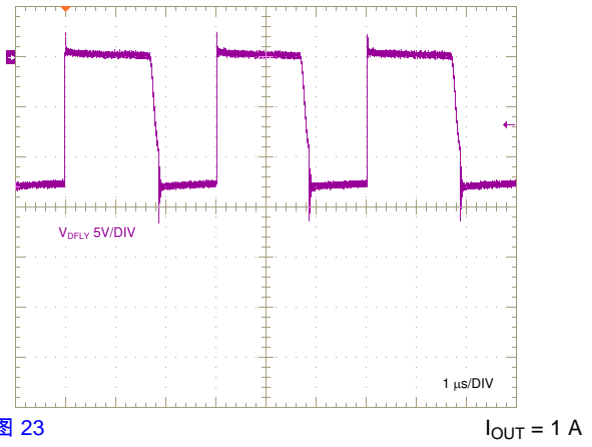

See 图 23

$I_{OUT} = 1\text{ A}$

图 4. Flyback Diode Switching Waveform in BCM

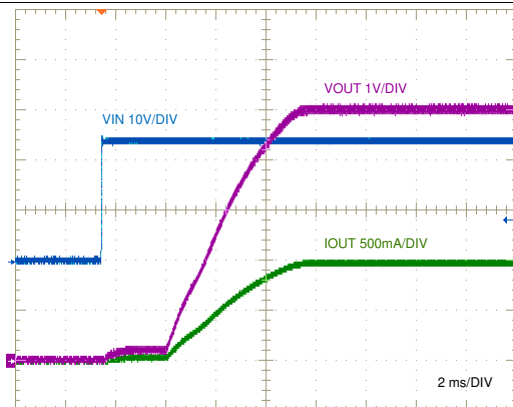

See 图 23

图 5. Startup Characteristic

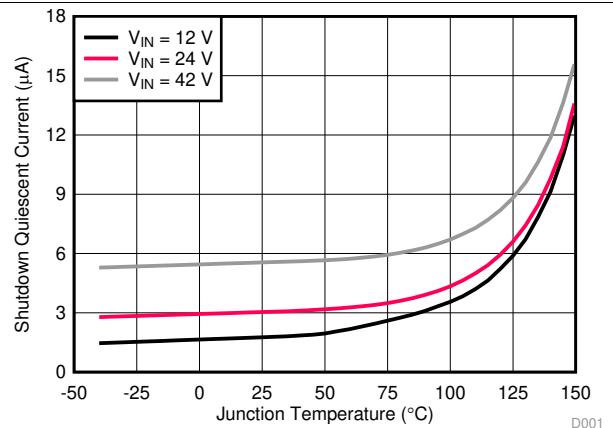

D001

图 6. Shutdown Quiescent Current vs. Temperature

Typical Characteristics (接下页)

$V_{IN} = 24\text{ V}$ ,  $V_{EN/UVLO} = 2\text{ V}$  (unless otherwise stated).



图 7. Active Quiescent Current vs. Temperature



$V_{SS/BIAS} = 6\text{ V}$

图 8. Active Quiescent Current with BIAS vs. Temperature

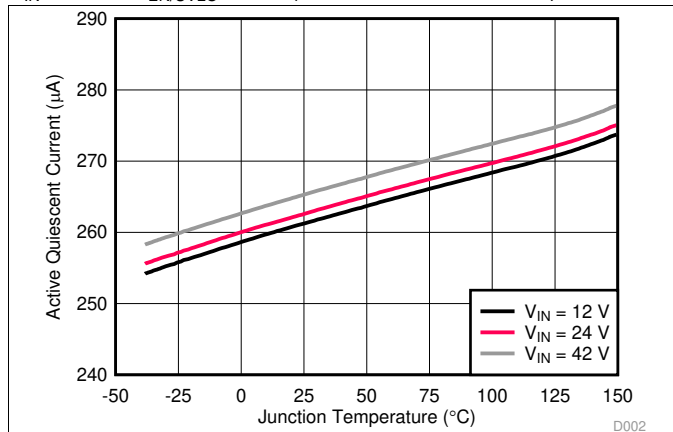
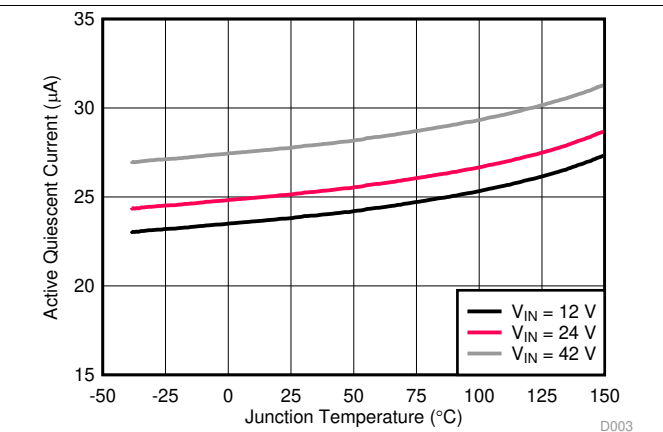

图 9. RSET Current vs. Input Voltage



图 10. RSET Current vs. Temperature

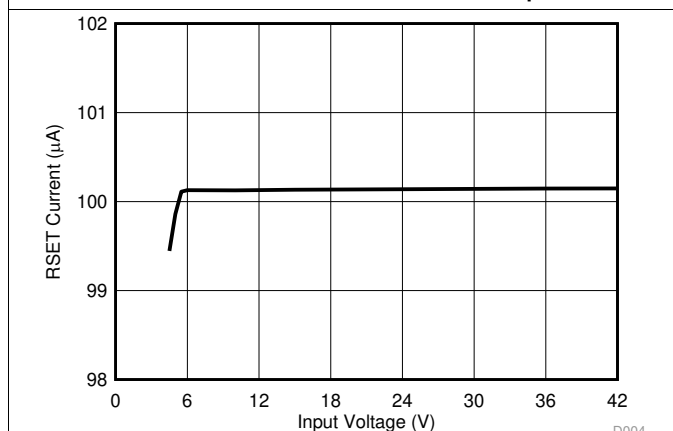

图 11. TC Voltage vs. Temperature

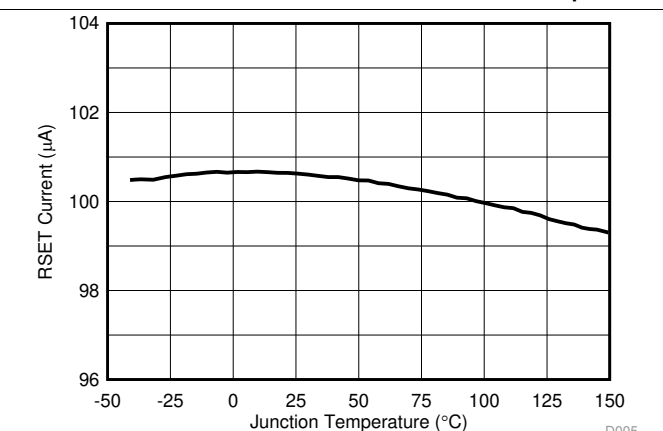

图 12. EN/UVLO Threshold Voltages vs. Temperature

ADVANCE INFORMATION

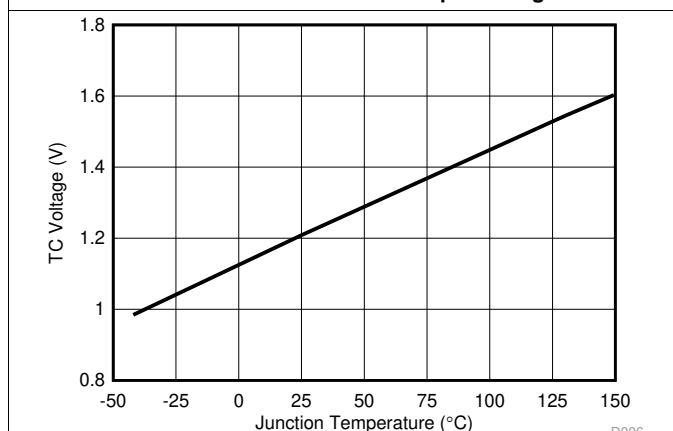
Typical Characteristics (接下页)

$V_{IN} = 24\text{ V}$ ,  $V_{EN/UVLO} = 2\text{ V}$  (unless otherwise stated).

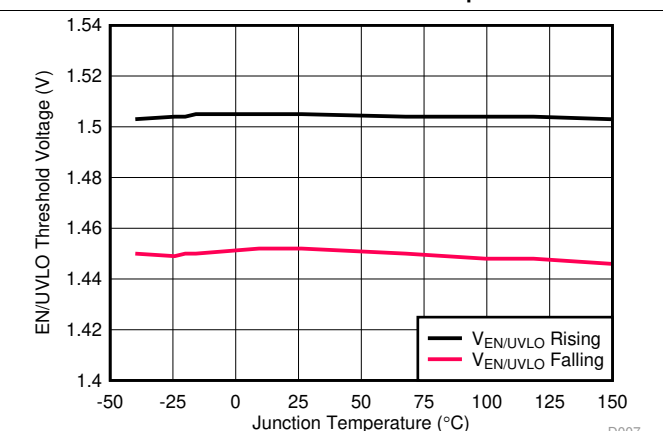

图 13. EN/UVLO Hysteresis Current vs. Temperature



图 14. MOSFET  $R_{DS(on)}$  vs. Temperature

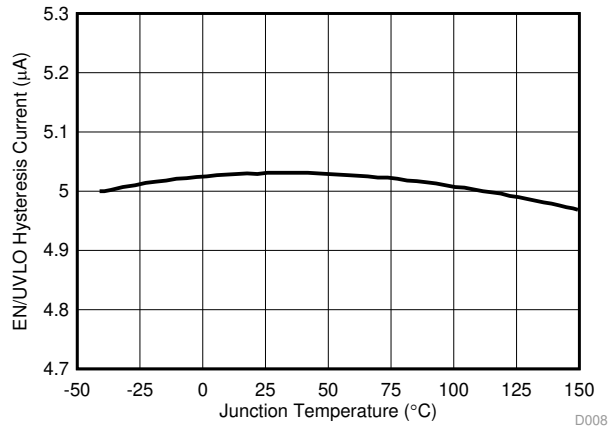

图 15. Switch Peak Current Limits vs. Temperature

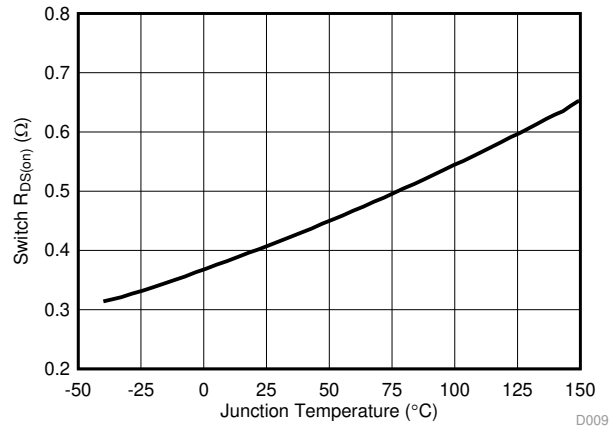

图 16. Minimum Switch On-Time vs. Temperature

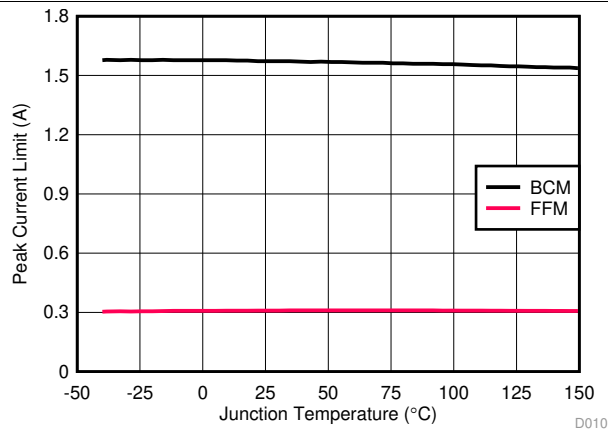

图 17. Minimum Switching Frequency vs. Temperature

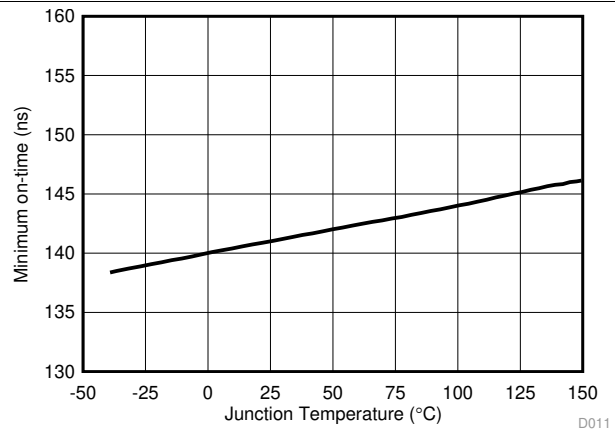

图 18. Maximum Switching Frequency vs. Temperature

ADVANCE INFORMATION

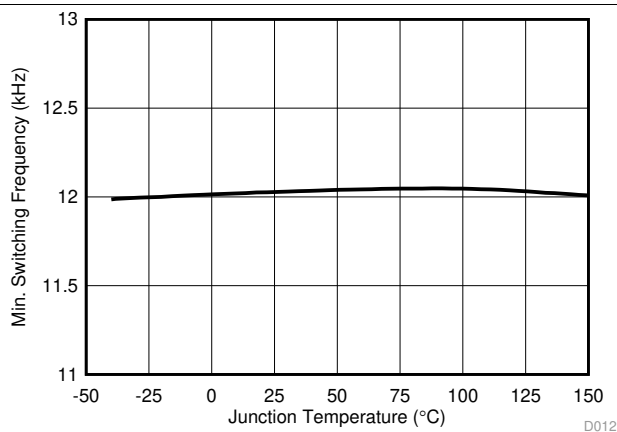
## 7 Detailed Description

### 7.1 Overview

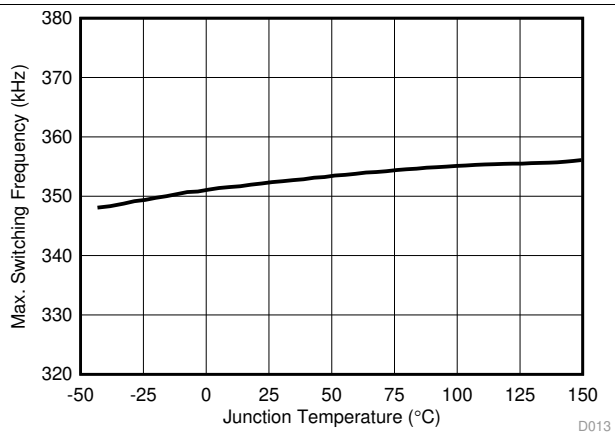
The LM25180-Q1 primary-side regulated (PSR) flyback converter is a high-density, cost-effective solution for automotive and industrial systems requiring less than 7 W of isolated DC/DC power. This compact, easy-to-use flyback converter with low  $I_Q$  can be applied over a wide input voltage range from 4.5 V to 42 V, with operation down to 3.5 V after startup. Innovative frequency and current amplitude modulation enables high conversion efficiency across the entire load and line range. Primary-side regulation of the isolated output voltage using sampled values of the primary winding voltage eliminates the need for an opto-coupler or an auxiliary transformer winding for feedback. Regulation performance that rivals that of traditional opto-coupler solutions is achieved without the associated cost, solution size and reliability concerns. The LM25180-Q1 converter services a wide range of applications including automotive on-board chargers and IGBT-based motor drives for HEV/EV systems.

### 7.2 Functional Block Diagram

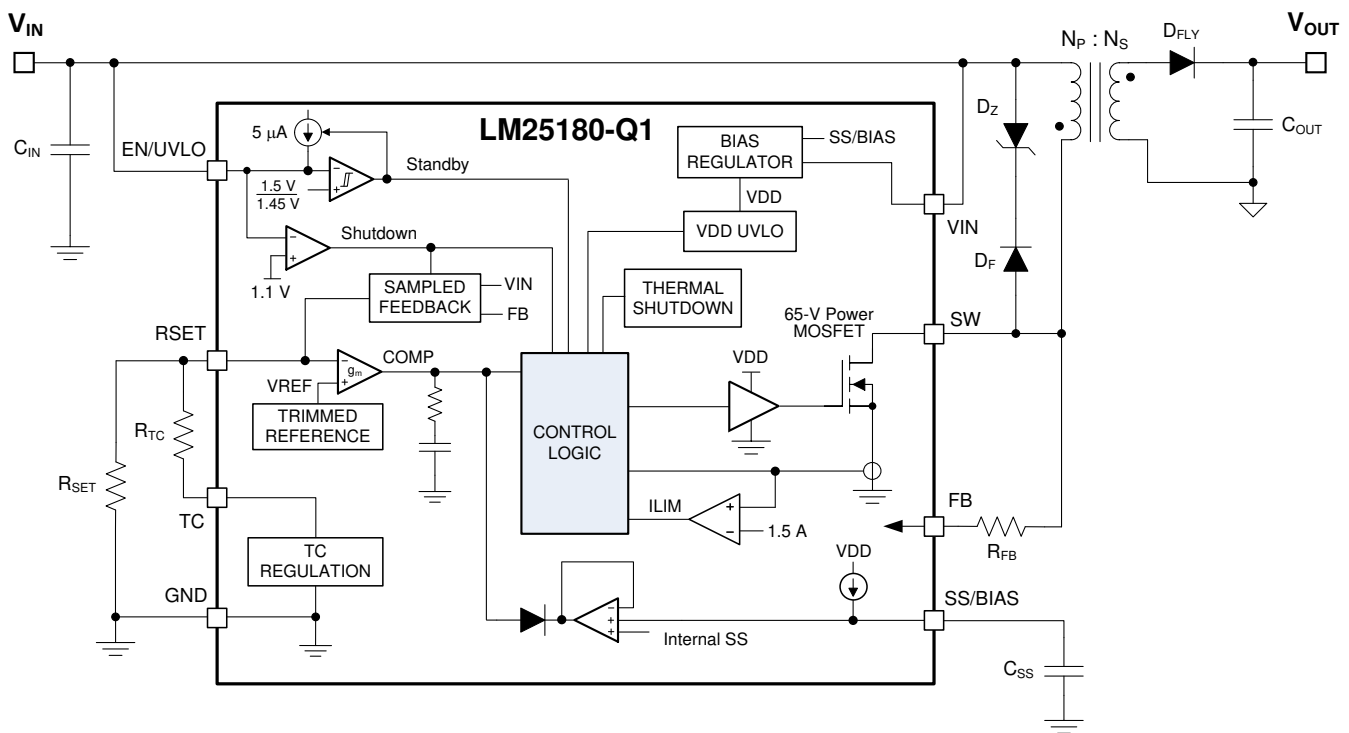

ADVANCE INFORMATION

### 7.3 Feature Description

#### 7.3.1 Integrated Power MOSFET

The LM25180-Q1 is a flyback dc/dc converter with integrated 65-V, 1.5-A N-channel power MOSFET. During the MOSFET on-time, the transformer primary current increases from zero with slope  $V_{IN} / L_{MAG}$  (where  $L_{MAG}$  is the transformer primary-referred magnetizing inductance) while the output capacitor supplies the load current. When the high-side MOSFET is turned off by the control logic, the SW voltage  $V_{SW}$  swings up to approximately  $V_{IN} + (N_{PS} \times V_{OUT})$ , where  $N_{PS} = N_P/N_S$  is the primary-to-secondary turns ratio of the transformer. The magnetizing current flows in the secondary side through the flyback diode, charging the output capacitor and supplying current to the load. Duty cycle  $D$  is defined as  $t_{ON} / t_{SW}$ , where  $t_{ON}$  is the MOSFET conduction time and  $t_{SW}$  is the switching period.

Figure 19 shows a typical schematic of the LM25180-Q1 PSR flyback circuit. Components denoted in red are optional depending on the application requirements.

Feature Description (接下页)



图 19. LM25180-Q1 Flyback Converter Schematic (Optional Components in Red)

7.3.2 PSR Flyback Modes of Operation

The LM25180-Q1 uses a variable-frequency, peak current-mode (VFPCM) control architecture with three possible modes of operation as illustrated in 图 20.

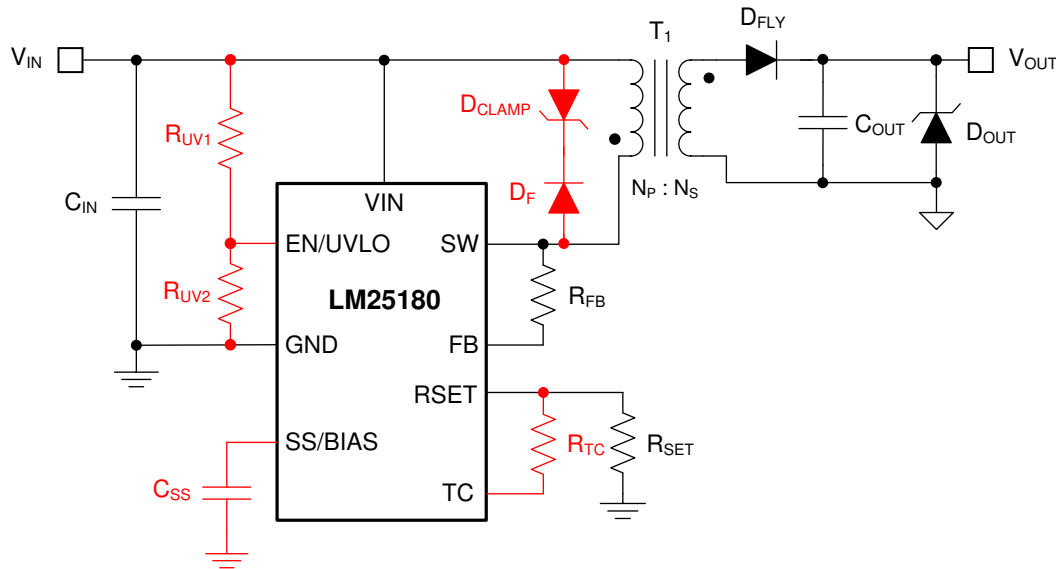

图 20. Three Modes of Operation Illustrated by Variation of Switching Frequency With Load

## Feature Description (接下页)

The LM25180-Q1 operates in boundary conduction mode (BCM) at heavy loads. The power MOSFET turns on when the current in the secondary winding reaches zero, and the MOSFET turns off when the peak primary current reaches the level dictated by the output of the internal error amplifier. As the load is decreased, the frequency increases in order to maintain BCM operation. The duty cycle of the flyback converter is given [公式 1](#), where  $V_D$  is the forward voltage drop of the flyback diode as its current approaches zero.

$$D_{\text{BCM}} = \frac{(V_{\text{OUT}} + V_D) \cdot N_{\text{PS}}}{V_{\text{IN}} + (V_{\text{OUT}} + V_D) \cdot N_{\text{PS}}} \quad (1)$$

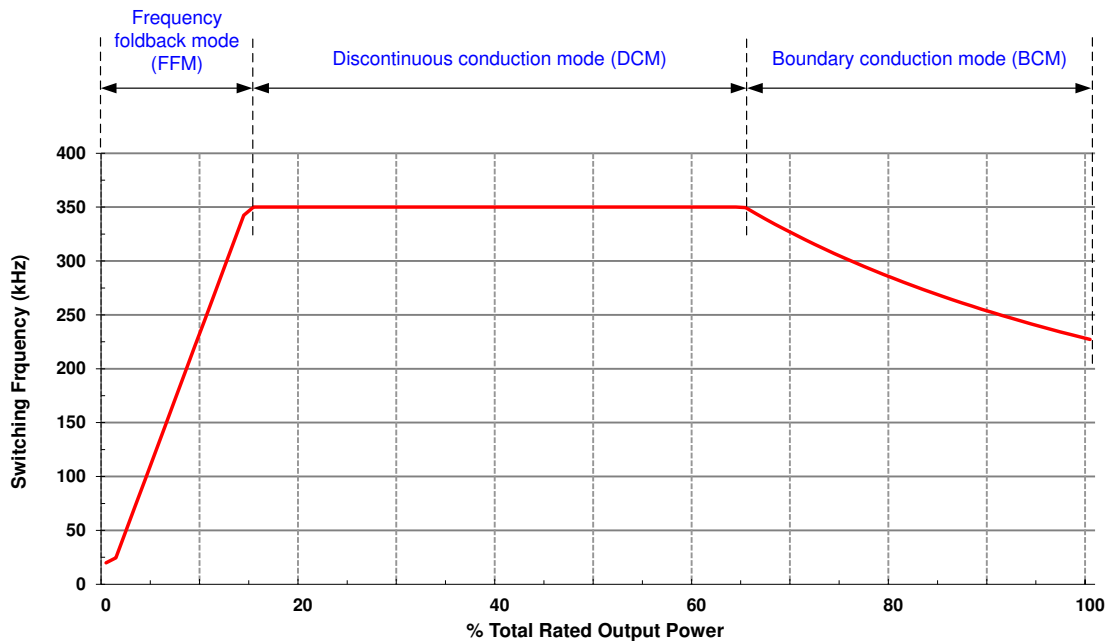
The output power in BCM is given by [公式 2](#), where the applicable switching frequency and peak primary current in BCM are specified by [公式 3](#) and [公式 4](#), respectively.

$$P_{\text{OUT(BCM)}} = \frac{L_{\text{MAG}} \cdot I_{\text{PRI-PK(BCM)}}^2}{2} \cdot F_{\text{SW(BCM)}} \quad (2)$$

$$F_{\text{SW(BCM)}} = \frac{1}{I_{\text{PRI-PK(BCM)}} \cdot \left( \frac{L_{\text{MAG}}}{V_{\text{IN}}} + \frac{L_{\text{MAG}}}{N_{\text{PS}} \cdot (V_{\text{OUT}} + V_D)} \right)} \quad (3)$$

$$I_{\text{PRI-PK(BCM)}} = \frac{2 \cdot (V_{\text{OUT}} + V_D) \cdot I_{\text{OUT}}}{V_{\text{IN}} \cdot D} \quad (4)$$

As the load decreases, the LM25180-Q1 clamps the maximum switching frequency to 350 kHz, and the converter enters discontinuous conduction mode (DCM). The power delivered to the output in DCM is proportional to the peak primary current squared as given by [公式 5](#) and [公式 6](#). Thus, as the load decreases, the peak current reduces to maintain regulation at 350-kHz switching frequency.

$$P_{\text{OUT(DCM)}} = \frac{L_{\text{MAG}} \cdot I_{\text{PRI-PK(DCM)}}^2}{2} \cdot F_{\text{SW(DCM)}} \quad (5)$$

$$I_{\text{PRI-PK(DCM)}} = \sqrt{\frac{2 \cdot I_{\text{OUT}} \cdot (V_{\text{OUT}} + V_D)}{L_{\text{MAG}} \cdot F_{\text{SW(DCM)}}}} \quad (6)$$

$$D_{\text{DCM}} = \frac{L_{\text{MAG}} \cdot I_{\text{PRI-PK(DCM)}} \cdot F_{\text{SW(DCM)}}}{V_{\text{IN}}} \quad (7)$$

At even lighter loads, the primary-side peak current set by the internal error amplifier decreases to a minimum level of 0.3 A, or 20% of its 1.5-A peak value, and the MOSFET off-time extends to maintain the output load requirement. The system operates in frequency foldback mode (FFM), and the switching frequency decreases as the load current is reduced. Other than a fault condition, the lowest frequency of operation of the LM25180-Q1 is 12 kHz, which sets a minimum load requirement of approximately 0.5% full load.

### 7.3.3 Setting the Output Voltage

To minimize output voltage regulation error, the LM25180-Q1 senses the reflected secondary voltage when the secondary current reaches zero. The feedback (FB) resistor, which is connected between SW and FB as shown in [图 19](#), is determined using [公式 8](#), where  $R_{\text{SET}}$  is nominally 12.1 k $\Omega$ .

$$R_{\text{FB}} = (V_{\text{OUT}} + V_D) \cdot N_{\text{PS}} \cdot \frac{R_{\text{SET}}}{V_{\text{REF}}} \quad (8)$$

## Feature Description (接下页)

### 7.3.3.1 Diode Thermal Compensation

The LM25180-Q1 employs a unique thermal compensation circuit that adjusts the feedback setpoint based on the thermal coefficient of the flyback diode's forward voltage drop. Even though the output voltage is measured when the secondary current is effectively zero, there is still a non-zero forward voltage drop associated with the flyback diode. Select the thermal compensation resistor using 公式 9.

$$R_{TC} = \frac{R_{FB} \cdot 3\text{mV}/^{\circ}\text{C}}{N_{PS} \cdot TC_{\text{Diode}}} \quad (9)$$

The temperature coefficient of the diode voltage drop may not be explicitly provided in the diode datasheet, so the effective value can be estimated based on the measured output voltage shift over temperature when the TC resistor is not installed.

### 7.3.4 Control Loop Error Amplifier

The inputs of the error amplifier include a level-shifted version of the FB voltage and an internal 1.21-V reference set by the resistor at RSET. A type-2 internal compensation network stabilizes the converter. In BCM operation when the output voltage is in regulation, an on-time interval is initiated when the secondary current reaches zero. The power MOSFET is subsequently turned off when an amplified version of the peak primary current exceeds the error amplifier output.

### 7.3.5 Precision Enable

The precision EN/UVLO input supports adjustable input undervoltage lockout (UVLO) with hysteresis for application specific power-up and power-down requirements. EN/UVLO connects to a comparator with a 1.5-V reference voltage and 50-mV hysteresis. An external logic signal can be used to drive the EN/UVLO input to toggle the output on and off for system sequencing or protection. The simplest way to enable the LM25180-Q1 is to connect EN/UVLO directly to  $V_{IN}$ . This allows the LM25180-Q1 to start up when  $V_{IN}$  is within its valid operating range. However, many applications benefit from using a resistor divider  $R_{UV1}$  and  $R_{UV2}$  as shown in 图 21 to establish a precision UVLO level.



图 21. Programmable Input Voltage UVLO With Hysteresis

Use 公式 10 和 公式 11 来计算输入 UVLO 电压的上升和下降电压，分别地，其中  $V_{UV-RISING}$  和  $V_{UV-FALLING}$  是 UVLO 比较器阈值和  $I_{UV-HYST}$  是迟滞电流。

$$V_{IN(on)} = V_{UV-RISING} \left( 1 + \frac{R_{UV1}}{R_{UV2}} \right) \quad (10)$$

$$V_{IN(off)} = V_{UV-FALLING} \left( 1 + \frac{R_{UV1}}{R_{UV2}} \right) - I_{UV-HYST} \cdot R_{UV2} \quad (11)$$

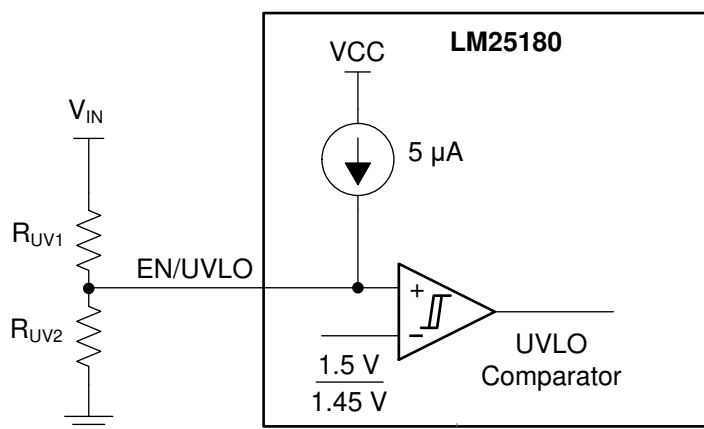
## Feature Description (接下页)

The LM25180-Q1 also provides a low- $I_Q$  shutdown mode when the EN/UVLO voltage is pulled below a base-emitter voltage drop (approximately 0.6 V at room temperature). If the EN/UVLO voltage is below this hard shutdown threshold, the internal LDO regulator powers off, and the internal bias-supply rail collapses, shutting down the bias currents of the LM25180-Q1. The LM25180-Q1 operates in standby mode when the EN/UVLO voltage is between the hard shutdown and precision-enable thresholds.

### 7.3.6 Configurable Soft Start

The LM25180-Q1 has a flexible and easy-to-use soft-start control pin, SS/BIAS. The soft-start feature prevents inrush current impacting the LM25180-Q1 and the input supply when power is first applied. This is achieved by controlling the voltage at the output of the internal error amplifier. Soft start is achieved by slowly ramping up the target regulation voltage when the device is first enabled or powered up. Selectable and adjustable start-up timing options include a 6-ms internally-fixed soft start and an externally-programmable soft start.

The simplest way to use the LM25180-Q1 is to leave SS/BIAS open. The LM25180-Q1 employs an internal soft-start control ramp and starts up to the regulated output voltage in 6 ms.

However, in applications with a large amount of output capacitance, higher  $V_{OUT}$  or other special requirements, the soft-start time can be extended by connecting an external capacitor  $C_{SS}$  from SS/BIAS to GND. A longer soft-start time further reduces the supply current needed to charge the output capacitors while sourcing the required load current. When the EN/UVLO voltage exceeds the UVLO rising threshold and a delay of 20  $\mu$ s expires, an internal current source  $I_{SS}$  of 5  $\mu$ A charges  $C_{SS}$  and generates a ramp to control the primary current amplitude. Calculate the soft-start capacitance for a desired soft-start time,  $t_{SS}$ , using 公式 12.

$$C_{SS} [\text{nF}] = 5 \cdot t_{SS} [\text{ms}] \tag{12}$$

$C_{SS}$  is discharged by an internal FET when switching is disabled by EN/UVLO or thermal shutdown.

### 7.3.7 External Bias Supply



图 22. External Bias Supply Using Transformer Auxiliary Winding

The LM25180-Q1 has an external bias supply feature that reduces input quiescent current and increases efficiency. When the voltage at SS/BIAS exceeds a rising threshold of 5.5 V, bias power for the internal LDO regulator can be derived from an external voltage source or from a transformer auxiliary winding as shown in 图 22. With a bias supply connected, the LM25180-Q1 then uses its internal soft-start ramp to control the primary current during start-up.

## Feature Description (接下页)

When using a transformer auxiliary winding for bias power, the total leakage current related to diodes  $D_{\text{BIAS1}}$  and  $D_{\text{BIAS2}}$  in 图 22 should be less than 1  $\mu\text{A}$  across the full operating temperature range.

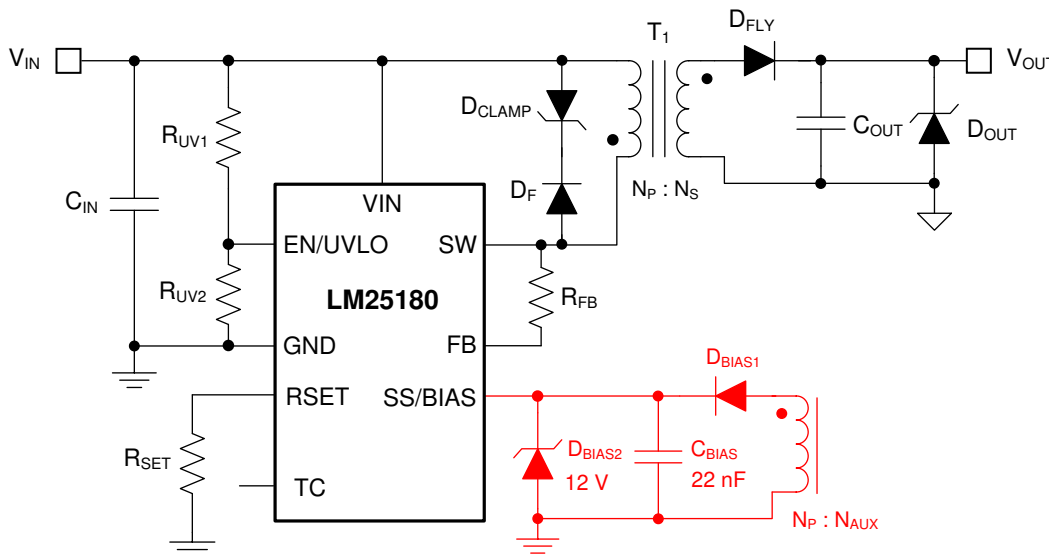
### 7.3.8 Minimum On-Time and Off-Time

When the internal power MOSFET is turned off, the leakage inductance of the transformer resonates with the SW node parasitic capacitance. The resultant ringing behavior can be excessive with large transformer leakage inductance and may corrupt the secondary zero-current detection. In order to prevent such a situation, a minimum switch off-time, designated as  $t_{\text{OFF-MIN}}$ , of maximum 450 ns is set internally to ensure proper functionality. This sets a lower limit for the transformer magnetizing inductance as discussed in [Detailed Design Procedure](#).

Furthermore, noise effects as a result of power MOSFET turn-on can impact the internal current sense circuit measurement. To mitigate this effect, the LM25180-Q1 provides a blanking time after the MOSFET turns on. This blanking time forces a minimum on-time,  $t_{\text{ON-MIN}}$ , of 140 ns.

### 7.3.9 Overcurrent Protection

In case of an overcurrent condition on the isolated output(s), the output voltage drops lower than the regulation level since the maximum power delivered is limited by the peak current capability on the primary side. The peak primary current is maintained at 1.5 A (plus an amount related to the 100-ns propagation delay of the current limit comparator) until the output decreases to the secondary diode voltage drop to impact the reflected signal on the primary side. At this point, the LM25180-Q1 assumes the output cannot be recovered and re-calibrates its switching frequency to 9 kHz until the overload condition is removed. The LM25180-Q1 responds with similar behavior to an output short circuit condition.

For a given input voltage, 公式 13 gives the maximum output current prior to the engagement of overcurrent protection. The typical threshold value for  $I_{\text{SW-PEAK}}$  from [Specifications](#) is 1.5 A.

$$I_{\text{OUT(max)}} = \frac{I_{\text{SW-PEAK}}}{2 \cdot \left( \frac{V_{\text{OUT}} + V_{\text{D}}}{V_{\text{IN}}} + \frac{1}{N_{\text{PS}}} \right)} \quad (13)$$

A failsafe current limit set at 2.4A, or 1.6 times the nominal peak current limit, provides redundant fault protection in case of transformer short circuit or saturation effects. This initiates a 7.5ms hiccup interval after eight overcurrent events.

### 7.3.10 Thermal Shutdown

Thermal shutdown is an integrated self-protection to limit junction temperature and prevent damage related to overheating. Thermal shutdown turns off the device when the junction temperature exceeds 175°C to prevent further power dissipation and temperature rise. Junction temperature decreases after shutdown, and the restarts when the junction temperature falls to 169°C.

## 7.4 Device Functional Modes

### 7.4.1 Shutdown Mode

EN/UVLO facilitates ON and OFF control for the LM25180-Q1. When  $V_{EN/UVLO}$  is below approximately 0.6 V, the device is in shutdown mode. Both the internal LDO and the switching regulator are off. The quiescent current in shutdown mode drops to 3  $\mu$ A at  $V_{IN} = 24$  V. The LM25180-Q1 also employs internal bias rail undervoltage protection. If the internal bias supply voltage is below its UV threshold, the converter remains off.

### 7.4.2 Standby Mode

The internal bias rail LDO regulator has a lower enable threshold than the converter itself. When  $V_{EN/UVLO}$  is above 0.6 V and below the precision-enable threshold (1.5 V typically), the internal LDO is on and regulating. The precision enable circuitry is turned on once the internal VCC is above its UV threshold. The switching action and voltage regulation are not enabled until  $V_{EN/UVLO}$  rises above the precision enable threshold.

### 7.4.3 Active Mode

The LM25180-Q1 is in active mode when  $V_{EN/UVLO}$  is above the precision-enable threshold and the internal bias rail is above its UV threshold. The LM25180-Q1 operates in one of three modes depending on the load current requirement:

1. Boundary conduction mode (BCM) at heavy loads.
2. Discontinuous conduction mode (DCM) at medium loads.
3. Frequency foldback mode (FFM) at light loads.

Refer to [PSR Flyback Modes of Operation](#) for more detail.

## 8 Application and Implementation

注

Information in the following applications sections is not part of the TI component specification, and TI does not warrant its accuracy or completeness. TI's customers are responsible for determining suitability of components for their purposes. Customers should validate and test their design implementation to confirm system functionality.

### 8.1 Application Information

The LM25180-Q1 requires only a few external components to convert from a wide range of supply voltages to one or more isolated output rails. To expedite and streamline the process of designing of a LM25180-Q1-based converter, a comprehensive LM25180-Q1 [quick-start calculator](#) is available for download to assist the designer with component selection for a given application. WEBENCH® online software is also available to generate complete designs, leveraging iterative design procedures and access to comprehensive component databases. The following sections discuss the design procedure for both single- and dual-output implementations using specific circuit design examples.

As mentioned previously, the LM25180-Q1 also integrates several optional features to meet system design requirements, including precision enable, input UVLO, programmable soft start, output voltage thermal compensation, and external bias supply connection. Each application incorporates these features as needed for a more comprehensive design.

The application circuits detailed in [Typical Applications](#) show LM25180-Q1 configuration options suitable for several application use cases. Refer to the [LM5180EVM-S05](#) and [LM5180EVM-DUAL](#) EVM user's guides for more detail.

### 8.2 Typical Applications

For step-by-step design procedures, circuit schematics, bill of materials, PCB files, simulation and test results of LM25180-Q1-powered implementations, refer to the [TI Designs](#) reference design library.

#### 8.2.1 Design 1: Wide $V_{IN}$ , Low $I_Q$ PSR Flyback Converter Rated at 5 V, 1 A

The schematic diagram of a 5-V, 1-A PSR flyback converter is given in [图 23](#).



图 23. Schematic for Design 1 With  $V_{IN(nom)} = 24 V$ ,  $V_{OUT} = 5 V$ ,  $I_{OUT} = 1 A$

#### 8.2.1.1 Design Requirements

The required input, output, and performance parameters for this application example are shown in [表 1](#).

**表 1. Design Parameters**

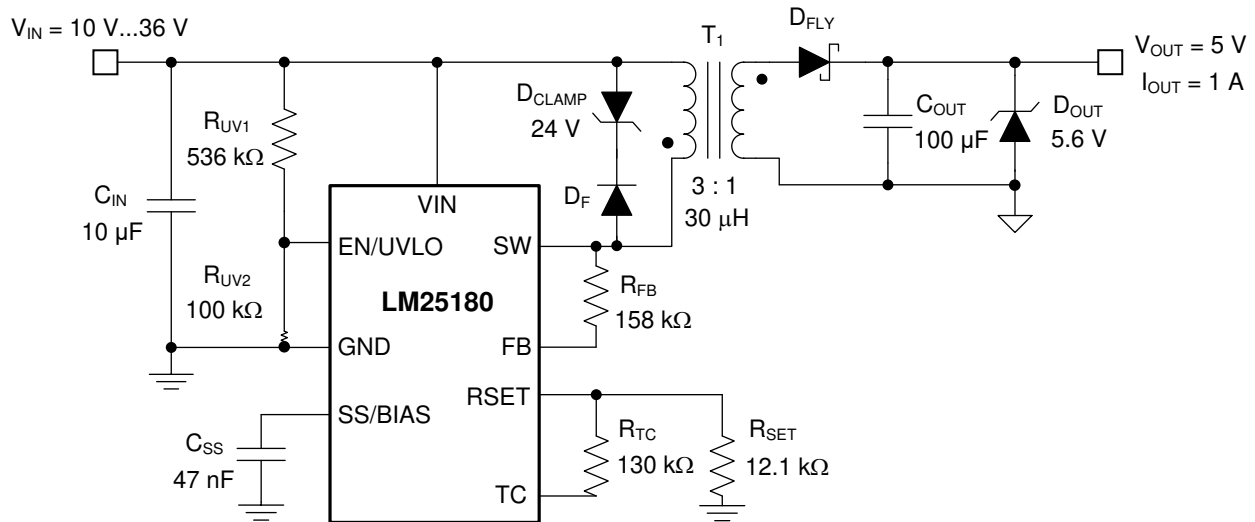
DESIGN PARAMETER	VALUE
Input voltage range	10 V to 36 V
Input UVLO thresholds	9.5 V on, 6.5 V off
Output voltage	5 V
Rated load current, $V_{IN} = 24$ V	1 A
Output voltage regulation	±1.5%
Output voltage ripple	< 100 mV

The target full-load efficiency is 86% based on a nominal input voltage of 24 V and an isolated output voltage of 5 V. The LM25180-Q1 is chosen to deliver a fixed 5-V output voltage set by resistor  $R_{FB}$  connected between the SW and FB pins. The input voltage turn-on and turn-off thresholds are established by  $R_{UV1}$  and  $R_{UV2}$ . The required components are listed in [表 2](#).

**表 2. List of Components for Design 1**

REF DES	QTY	SPECIFICATION	VENDOR	PART NUMBER
$C_{IN}$	1	10 $\mu$ F, 50 V, X7R, 1210, ceramic, AEC-Q200	Taiyo Yuden	UMJ325KB7106KMHT
$C_{OUT}$	1	100 $\mu$ F, 6.3 V, X7S, 1210, ceramic	Murata	GRM32EC70J107ME15
			Taiyo Yuden	JMK325AC7107MM-P
		100 $\mu$ F, 6.3 V, X5R, 1210, ceramic	TDK	C3225X5R0J107M250AC
			Würth Electronik	885012109004
$C_{SS}$	1	47 nF, 16 V, X7R, 0402	Std	Std
$D_{CLAMP}$	1	Zener, 24 V, 1 W, PowerDI-123, AEC-Q101	DFLZ24Q-7	Diodes Inc.
$D_F$	1	Switching diode, 75 V, 0.25 A, SOD-323	CMDD4448	Central Semi
$D_{FLY}$	1	Schottky diode, 40 V, 2 A, SOD-123	FSV340FP	ONsemi
$D_{OUT}$	1	Zener, 5.6 V, 5%, SOD-523, AEC-Q101	BZX585-C5V6	Nexperia
$R_{FB}$	1	158 k $\Omega$ , 1%, 0402	Std	Std
$R_{SET}$	1	12.1 k $\Omega$ , 1%, 0402	Std	Std
$R_{TC}$	1	130 k $\Omega$ , 1%, 0402	Std	Std
$R_{UV1}$	1	536 k $\Omega$ , 1%, 0603	Std	Std
$R_{UV2}$	1	100 k $\Omega$ , 1%, 0402	Std	Std
$T_1$	1	30 $\mu$ H, 2 A, turns ratio 3 : 1, 9.3 $\times$ 10.2 mm	Coilcraft	<a href="#">YA8779-BLD</a>
			Würth Electronik	<a href="#">750317605</a>
		30 $\mu$ H, 2.6 A, turns ratio 3 : 1, 12.5 $\times$ 15.5 mm	Sumida	12387-T151
			Würth Electronik	<a href="#">750313974</a>
$U_1$	1	LM25180-Q1 PSR flyback converter, AEC-Q100	Texas Instruments	LM25180QNGURQ1

### 8.2.1.2 Detailed Design Procedure

#### 8.2.1.2.1 Custom Design With WEBENCH® Tools

[Click here](#) to create a custom design using the LM25180-Q1 device with WEBENCH® Power Designer.

1. Start by entering the input voltage ( $V_{IN}$ ), output voltage ( $V_{OUT}$ ), and output current ( $I_{OUT}$ ) requirements.
2. Optimize the design for key parameters such as efficiency, footprint, and cost using the optimizer dial.
3. Compare the generated design with other possible solutions from Texas Instruments.

The WEBENCH Power Designer provides a customized schematic along with a list of materials with real-time pricing and component availability.

In most cases, these actions are available:

- Run electrical simulations to see important waveforms and circuit performance
- Run thermal simulations to understand board thermal performance
- Export customized schematic and layout into popular CAD formats

- Print PDF reports for the design, and share the design with colleagues

Get more information about WEBENCH tools at [www.ti.com/WEBENCH](http://www.ti.com/WEBENCH).

### 8.2.1.2.2 Custom Design With Excel Quickstart Tool

Select components based on the converter specifications using the LM25180-Q1 [quick-start calculator](#).

### 8.2.1.2.3 Flyback Transformer – T<sub>1</sub>

Choose a turns ratio based on an approximate 60% max duty cycle at minimum input voltage using [公式 14](#), rounding up or down as needed.

$$N_{PS} = \frac{D_{MAX}}{1-D_{MAX}} \cdot \frac{V_{IN(min)}}{V_{OUT} + V_D} = \frac{0.6}{1-0.6} \cdot \frac{10V}{5V + 0.3V} = 3 \quad (14)$$

Select a magnetizing inductance based on the minimum off-time constraint using [公式 15](#). Choose a value of 30  $\mu$ H with a saturation current of minimum 2 A for this application.

$$L_{MAG} \geq \frac{(V_{OUT} + V_D) \cdot N_{PS} \cdot t_{OFF-MIN}}{I_{PRI-PK(FFM)}} = \frac{(5V + 0.3V) \cdot 3 \cdot 450ns}{0.3A} = 23.9\mu H \quad (15)$$

Note that a higher magnetizing inductance provides a larger operating range for BCM and FFM, but the leakage inductance may increase based on a higher number of primary turns,  $N_P$ . The primary and secondary winding RMS currents are given by [公式 16](#) and [公式 17](#), respectively.

$$I_{PRI-RMS} = \sqrt{\frac{D}{3}} \cdot I_{PRI-PK} \quad (16)$$

$$I_{SEC-RMS} = \sqrt{\frac{2 \cdot I_{OUT} \cdot I_{PRI-PK} \cdot N_{PS}}{3}} \quad (17)$$

Find the maximum output current for a given turns ratio using [公式 18](#), where the typical value for  $I_{PRI-PK(max)}$  is the 1.5 A switch current peak threshold. Iterate by increasing the turns ratio if the output current capability is too low at minimum input voltage.

$$I_{OUT(max)} = \frac{I_{PRI-PK(max)}}{2 \cdot \left[ \frac{V_{OUT} + V_D}{V_{IN}} + \frac{1}{N_{PS}} \right]} \quad (18)$$

### 8.2.1.2.4 Flyback Diode – D<sub>FLY</sub>

The flyback diode reverse voltage is given by [公式 19](#).

$$V_{D-REV} \geq \frac{V_{IN(max)}}{N_{PS}} + V_{OUT} = \frac{36V}{3} + 5V = 17V \quad (19)$$

Select a 40-V, 3-A Schottky diode for this application to account for inevitable diode voltage overshoot and ringing related to the resonance of transformer leakage inductance and diode parasitic capacitance. Connect an appropriate RC snubber circuit (for example, 100  $\Omega$  and 22 pF) across the flyback diode if needed.

In general, choose a flyback diode with current rating greater than the maximum peak secondary winding current of  $N_{PS} \cdot I_{PRI-PK(max)}$ . As mentioned in [Layout](#), place adequate copper at the cathode of the diode to improve its thermal performance and prevent overheating during high ambient temperature or overload conditions. Beware of the high leakage current typical of a Schottky diode at elevated operating temperatures.

### 8.2.1.2.5 Zener Clamp Circuit – D<sub>F</sub>, D<sub>CLAMP</sub>

Connect a diode-Zener clamping circuit across the primary winding to limit the peak switch-node voltage after MOSFET turn-off below the maximum level of 65 V, as given by [公式 20](#).

$$V_{DZ(\text{clamp})} < V_{SW(\text{max})} - V_{IN(\text{max})} \quad (20)$$

Choosing the zener,  $D_{\text{CLAMP}}$ , with clamp voltage of approximately 1.5 times the reflected output voltage, as specified by 公式 21, provides a balance between the maximum SW voltage excursion and the leakage inductance demagnetization time.

$$V_{DZ(\text{clamp})} = 1.5 \cdot N_{\text{PS}} \cdot (V_{\text{OUT}} + V_{\text{D}}) = 1.5 \cdot 3 \cdot (5\text{V} + 0.3\text{V}) \approx 24\text{V} \quad (21)$$

Select an ultra-fast switching diode or Schottky diode for  $D_{\text{F}}$  with rated voltage greater than the maximum input voltage and with low forward recovery voltage drop.

#### 8.2.1.2.6 Output Capacitor – $C_{\text{OUT}}$

The output capacitor determines the voltage ripple at the converter output, limits the voltage excursion during a load transient, and sets the dominant pole of the converter's small-signal response. For a flyback converter specifically, the output capacitor supplies the load current when the main switch is on, and therefore the output voltage ripple is a function of load current and duty cycle.

Select an output capacitance using 公式 22 to limit the ripple voltage amplitude to less than 1% of the output voltage at minimum input voltage.

$$C_{\text{OUT}} \geq \frac{I_{\text{OUT}(\text{max})}}{\Delta V_{\text{OUT}}} \cdot \frac{L_{\text{MAG}} \cdot I_{\text{PRI-PK}(\text{max})}}{V_{\text{IN}}} \quad (22)$$

Substituting the maximum load current at minimum input voltage from 公式 18, transformer inductance, peak switch current and peak-to-peak ripple voltage specification gives  $C_{\text{OUT}}$  greater than 72  $\mu\text{F}$ .

Mindful of the voltage coefficient of ceramic capacitors, select a 100- $\mu\text{F}$ , 6.3-V capacitor in 1210 case size with X5R or better dielectric. 公式 23 gives the output capacitor RMS ripple current.

$$I_{\text{COUT-RMS}} = I_{\text{OUT}} \cdot \sqrt{\frac{2 \cdot N_{\text{PS}} \cdot I_{\text{PRI-PK}}}{3 \cdot I_{\text{OUT}}} - 1} \quad (23)$$

#### 8.2.1.2.7 Input Capacitor – $C_{\text{IN}}$

Select an input capacitance using 公式 24 to limit the ripple voltage amplitude to less than 5% of the input voltage when operating at nominal input voltage.

$$C_{\text{IN}} \geq \frac{I_{\text{PRI-PK}} \cdot D \cdot \left(1 - \frac{D}{2}\right)^2}{2 \cdot F_{\text{SW}} \cdot \Delta V_{\text{IN}}} \quad (24)$$

Substituting the input current at full load, switching frequency, peak primary current and peak-to-peak ripple specification gives  $C_{\text{IN}}$  greater than 2  $\mu\text{F}$ . Mindful of the voltage coefficient of ceramic capacitors, select a 10- $\mu\text{F}$ , 50-V ceramic input capacitor with X7R dielectric in 1210 case size. 公式 25 gives the input capacitor RMS ripple current.

$$I_{\text{CIN-RMS}} = \frac{D \cdot I_{\text{PRI-PK}}}{2} \cdot \sqrt{\frac{4}{3 \cdot D} - 1} \quad (25)$$

#### 8.2.1.2.8 Feedback Resistor – $R_{\text{FB}}$

Select a feedback resistor, designated  $R_{\text{FB}}$ , of 158 k $\Omega$  based on the secondary winding voltage at the end of the flyback conduction interval (the sum of the 5-V output voltage and the Schottky diode forward voltage drop) reflected by the transformer turns ratio of 3 : 1. The forward voltage drop of the flyback diode is 0.3 V as its current approaches zero.

$$R_{\text{FB}} = \frac{(V_{\text{OUT}} + V_{\text{D}}) \cdot N_{\text{PS}}}{0.1\text{ mA}} = \frac{(5\text{V} + 0.3\text{V}) \cdot 3}{0.1\text{ mA}} = 158\text{ k}\Omega \quad (26)$$

**8.2.1.2.9 Thermal Compensation Resistor – R<sub>TC</sub>**

Select a resistor for output voltage thermal compensation, designated R<sub>TC</sub>, based on 公式 27.

$$R_{TC} = \frac{R_{FB}}{N_{PS}} \cdot \frac{3 \text{ mV}/^{\circ}\text{C}}{TC_{Diode}} = \frac{158 \text{ k}\Omega \cdot 3}{3 \cdot 1.2} = 130 \text{ k}\Omega \tag{27}$$

**8.2.1.2.10 UVLO Resistors – R<sub>UV1</sub>, R<sub>UV2</sub>**

Given V<sub>IN(on)</sub> and V<sub>IN(off)</sub> as the input voltage turn-on and turn-off thresholds of 9.5 V and 6.5 V, respectively, select the upper and lower UVLO resistors using the following expressions:

$$R_{UV1} = \frac{V_{IN(on)} \cdot \frac{V_{UV-FALLING}}{V_{UV-RISING}} - V_{IN(off)}}{I_{UV-HYST}} = \frac{9.5 \text{ V} \cdot \frac{1.45 \text{ V}}{1.5 \text{ V}} - 6.5 \text{ V}}{5 \mu\text{A}} = 536 \text{ k}\Omega \tag{28}$$

$$R_{UV2} = R_{UV1} \cdot \frac{V_{UV-RISING}}{V_{IN(on)} - V_{UV-RISING}} = 536 \text{ k}\Omega \cdot \frac{1.5 \text{ V}}{9.5 \text{ V} - 1.5 \text{ V}} = 100 \text{ k}\Omega \tag{29}$$

**8.2.1.2.11 Soft-Start Capacitor – C<sub>SS</sub>**

Connect an external soft-start capacitor for a specific soft-start time. In this example, select a soft-start capacitance of 47 nF based on 公式 12 to achieve a soft-start time of 9 ms.



For technical solutions, industry trends, and insights for designing and managing power supplies, please refer to TI's [Power Management](#) technical articles.

**8.2.1.3 Application Curves**

Unless otherwise stated, application performance curves were taken at T<sub>A</sub> = 25°C.

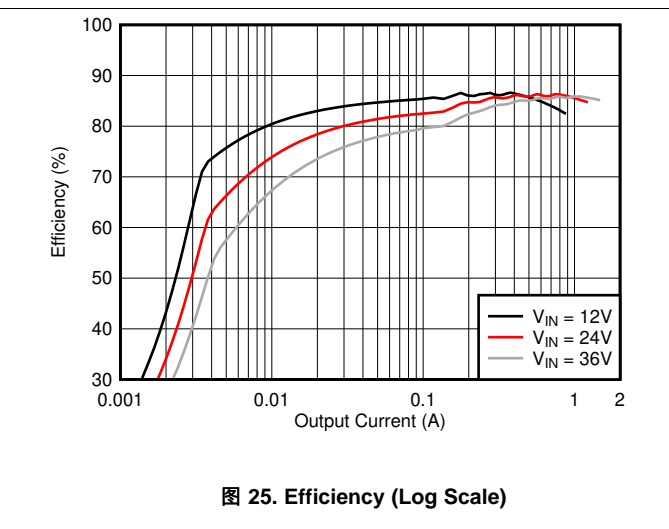
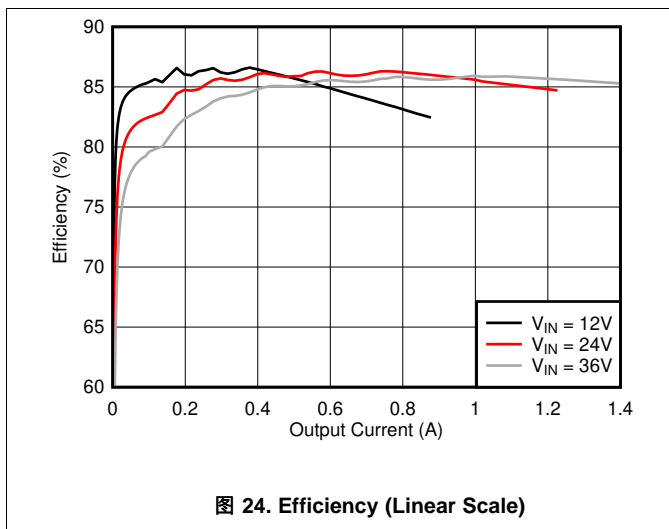

ADVANCE INFORMATION



图 26. Load Regulation (Linear Scale)



图 27. Load Regulation (Log Scale)

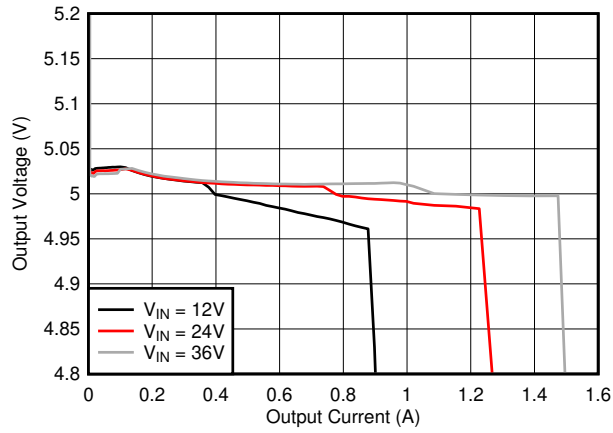

图 28. Start-up Characteristic

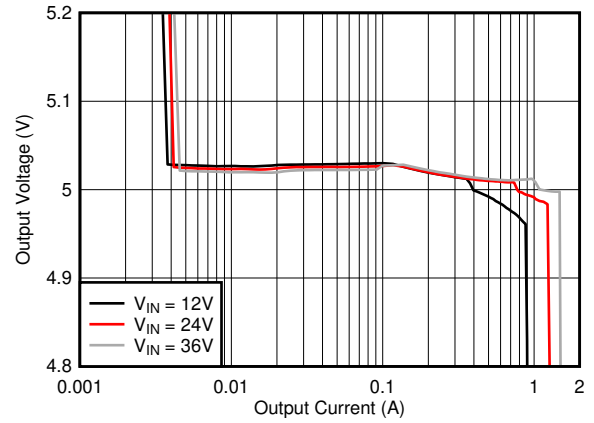

图 29. Enable ON Characteristic

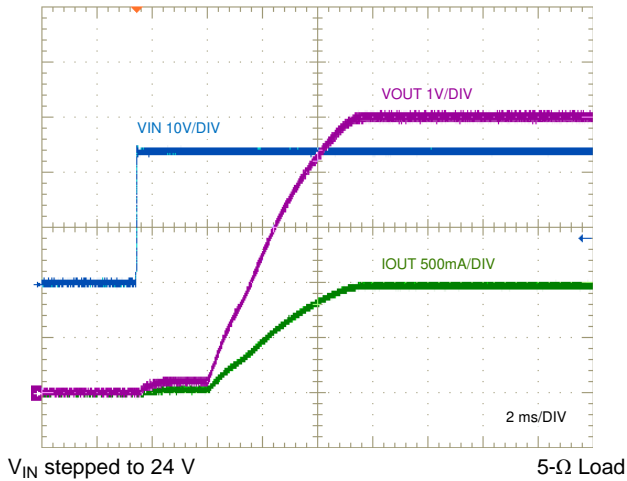

图 30. SW Node Voltage

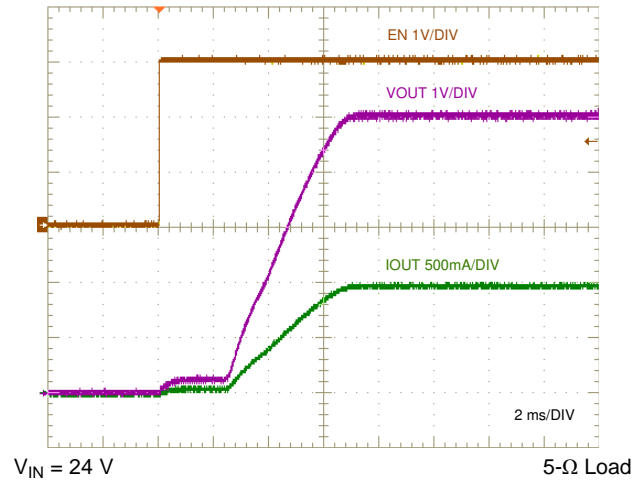

图 31. Flyback Diode Voltage

LM25180-Q1

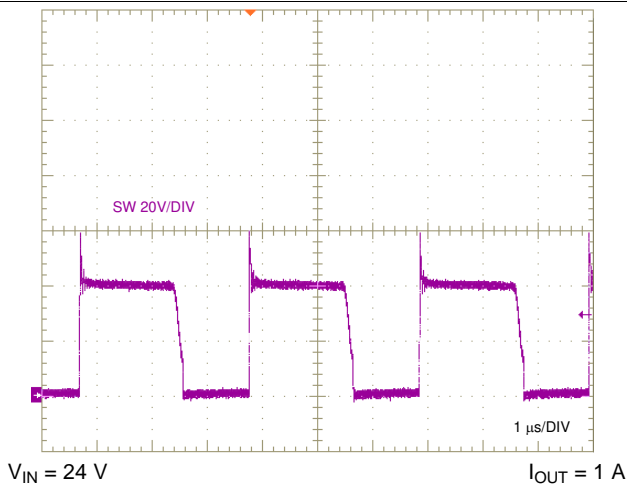
ZHCSJ08A –NOVEMBER 2018–REVISED JULY 2019

www.ti.com.cn

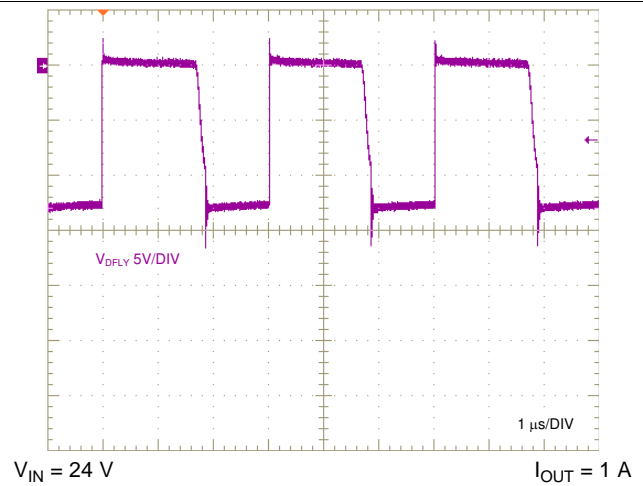
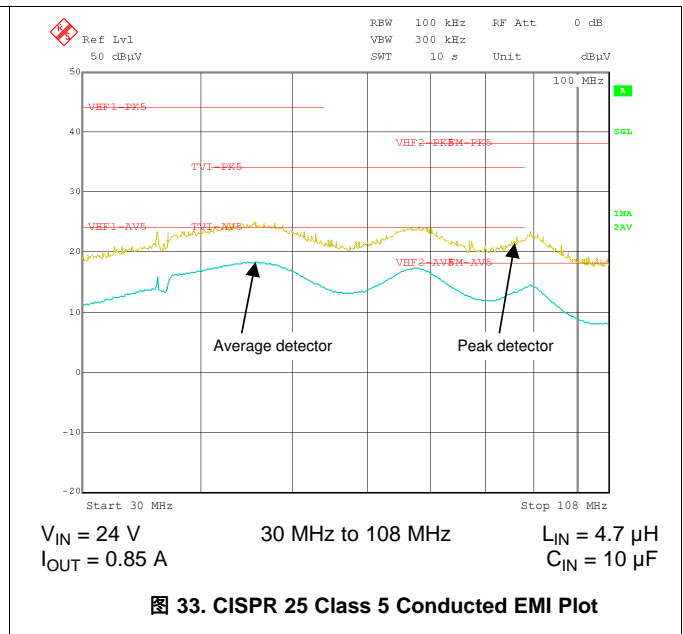
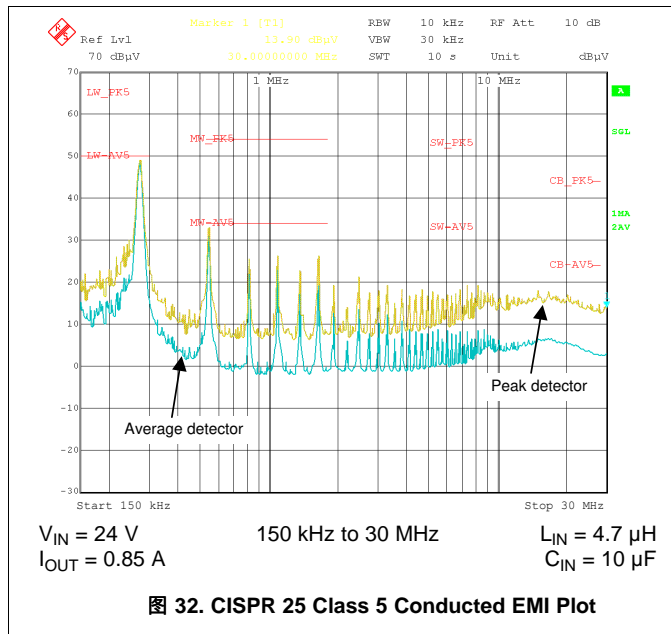

### 8.2.2 Design 2: PSR Flyback Converter With Dual Outputs of 15 V and –7.7 V at 200 mA

The schematic diagram of a dual-output flyback converter intended for isolated IGBT and SiC MOSFET gate drive power supply applications is given in 图 34.



图 34. Schematic for Design 2 With  $V_{IN(nom)} = 24\text{ V}$ ,  $V_{OUT1} = 15\text{ V}$ ,  $V_{OUT2} = -7.7\text{ V}$ ,  $I_{OUT} = 200\text{ mA}$

#### 8.2.2.1 Design Requirements

The required input, output, and performance parameters for this application example are shown in 表 3.

表 3. Design Parameters

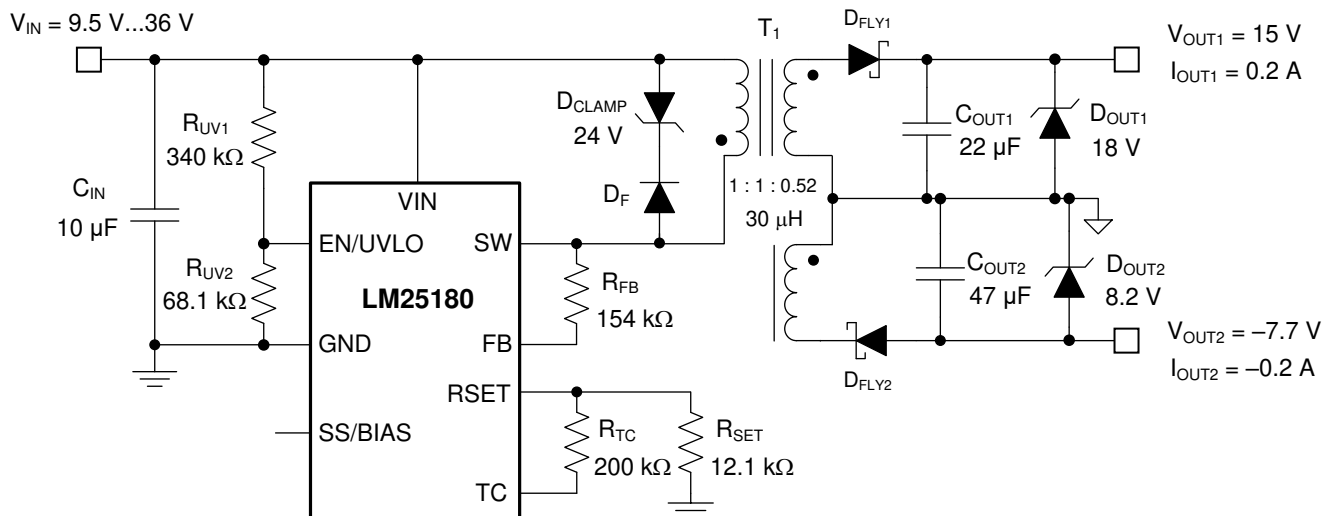
DESIGN PARAMETER	VALUE
Input voltage range (steady state)	9.5 V to 36 V
Output 1 voltage and current	15 V, 0.2 A
Output 2 voltage and current	-7.7 V, -0.2 A
Input UVLO thresholds	9 V on, 7 V off
Output voltage regulation	±2%

The target full-load efficiency of this LM25180-Q1 design is 88% based on a nominal input voltage of 24 V and isolated output voltages of 15 V and –7.7 V sharing a common return. The selected flyback converter components are cited in 表 4, including multi-winding flyback transformer, input and output capacitors, rectifying diodes and flyback converter IC.

**表 4. List of Components for Design 2**

REF DES	QTY	SPECIFICATION	VENDOR	PART NUMBER
C <sub>IN</sub>	1	10 μF, 50 V, X7R, 1210, ceramic, AEC-Q200	Taiyo Yuden	UMJ325KB7106KMHT
C <sub>OUT1</sub>	1	22 μF, 25 V, X7R, 1210, ceramic, AEC-Q200	TDK	CGA6P3X7R1E226M
			Murata	GCM32EC71E226KE36
			Taiyo Yuden	TMK325B7226KMHT
C <sub>OUT2</sub>	1	47 μF, 10 V, X7S, 1210, ceramic, AEC-Q200	Murata	GCM32EC71H106KA03
D <sub>FLY1</sub>	1	Schottky diode, 100 V, 1 A, PowerDI-123, AEC-Q101	DFLS1100Q-7	Diodes Inc.
D <sub>FLY2</sub>	1	Schottky diode, 60 V, 1 A, PowerDI-123, AEC-Q101	DFLS160Q-7	Diodes Inc.
D <sub>CLAMP</sub>	1	Zener, 24 V, 1 W, PowerDI-123, AEC-Q101	DFLZ24Q-7	Diodes Inc.
D <sub>F</sub>	1	Switching diode, 75 V, 0.3 A, SOD323, AEC-Q101	1N4148WSQ	Diodes Inc.
D <sub>OUT1</sub>	1	Zener, 18 V, 5%, SOD523, AEC-Q101	BZX585-C18	Nexperia
D <sub>OUT2</sub>	1	Zener, 8.2 V, 2%, SOD523, AEC-Q101	BZX585-B8V2	Nexperia
R <sub>FB</sub>	1	154 kΩ, 1%, 0402	Std	Std
R <sub>SET</sub>	1	12.1 kΩ, 1%, 0402	Std	Std
R <sub>TC</sub>	1	200 kΩ, 1%, 0402	Std	Std
R <sub>UV1</sub>	1	340 kΩ, 1%, 0603	Std	Std
R <sub>UV2</sub>	1	68.1 kΩ, 1%, 0402	Std	Std
T <sub>1</sub>	1	30 μH, 2 A, turns ratio 1 : 1 : 0.52, 9 × 10 mm, SMT	Coilcraft	YA8916-BLD
			Würth Elektronik	750317595
U <sub>1</sub>	1	LM25180-Q1 PSR flyback converter, AEC-Q100	Texas Instruments	LM25180QNGURQ1

### 8.2.2.2 Detailed Design Procedure

Using the LM25180-Q1 [quick-start calculator](#), components are selected based on the flyback converter specifications.

#### 8.2.2.2.1 Flyback Transformer – T<sub>1</sub>

Set the turns ratio of the transformer secondary windings using [公式 30](#), where N<sub>S1</sub> and N<sub>S2</sub> are the number of secondary turns for the respective outputs.

$$\frac{N_{S2}}{N_{S1}} = \frac{V_{OUT2} + V_{D2}}{V_{OUT1} + V_{D1}} = \frac{7.7 \text{ V} + 0.3 \text{ V}}{15 \text{ V} + 0.3 \text{ V}} = 0.52 \quad (30)$$

Choose a primary-secondary turns ratio for the 15-V output based on an approximate 60% max duty cycle at minimum input voltage using [公式 31](#). The transformer turns ratio for both outputs is thus specified as 1 : 1 : 0.52.

$$N_{PS} = \frac{D_{MAX}}{1 - D_{MAX}} \cdot \frac{V_{IN(min)}}{V_{OUT} + V_D} = \frac{0.6}{1 - 0.6} \cdot \frac{9.5 \text{ V}}{15 \text{ V} + 0.3 \text{ V}} \approx 1 \quad (31)$$

Select a magnetizing inductance based on the minimum off-time constraint using [公式 32](#). Choose a value of 30 μH with a saturation current of 2 A for this application.

$$L_{MAG} \geq \frac{(V_{OUT} + V_D) \cdot N_{PS} \cdot t_{OFF-MIN}}{I_{PRI-PK(FFM)}} = \frac{(15 \text{ V} + 0.35 \text{ V}) \cdot 1 \cdot 450 \text{ ns}}{0.3 \text{ A}} = 23.0 \mu\text{H} \quad (32)$$

#### 8.2.2.2.2 Flyback Diodes – D<sub>FLY1</sub> and D<sub>FLY2</sub>

The flyback diode reverse voltages for the positive and negative outputs are given respectively by [公式 33](#) and [公式 25](#).

$$V_{D1-REV} \geq \frac{V_{IN(max)}}{N_{PS}} + V_{OUT1} = \frac{36 \text{ V}}{1} + 15 \text{ V} = 51 \text{ V} \quad (33)$$

$$V_{D2-REV} \geq \frac{V_{IN(max)}}{N_{PS}} + |V_{OUT2}| = 36\text{ V} \cdot 0.52 + 7.7\text{ V} = 26.4\text{ V} \quad (34)$$

Choose 100-V, 1-A and 60-V, 1-A Schottky diodes for the positive and negative outputs, respectively, to allow some margin for inevitable voltage overshoot and ringing related to leakage inductance and diode capacitance. If needed, use a diode RC snubber circuit, for example 100 Ω and 22 pF, to mitigate such overshoot and ringing.

### 8.2.2.2.3 Input Capacitor – C<sub>IN</sub>

The input capacitor, C<sub>IN</sub>, filters the primary-side triangular current waveform. To prevent large ripple voltage, use a low-ESR ceramic input capacitor sized according to 公式 24 for the RMS ripple current given by 公式 25. In this design example, choose a 10-μF, 50-V ceramic input capacitor with X7R dielectric and 1210 footprint.

### 8.2.2.2.4 Feedback Resistor – R<sub>FB</sub>

Install a 154-kΩ resistor from SW to FB based on an output voltage setpoint of 15 V (plus a flyback diode voltage drop) reflected to the primary by a transformer turns ratio of unity.

$$R_{FB} = \frac{(V_{OUT} + V_D) \cdot N_{PS}}{0.1\text{ mA}} = \frac{(15\text{ V} + 0.3\text{ V}) \cdot 1}{0.1\text{ mA}} = 154\text{ k}\Omega \quad (35)$$

### 8.2.2.2.5 UVLO Resistors – R<sub>UV1</sub>, R<sub>UV2</sub>

Given V<sub>IN(on)</sub> and V<sub>IN(off)</sub> as the input voltage turn-on and turn-off thresholds of 9 V and 7 V, respectively, select the upper and lower UVLO resistors using 公式 36 and 公式 37.

$$R_{UV1} = \frac{V_{IN(on)} \cdot \frac{V_{UV-FALLING} - V_{IN(off)}}{V_{UV-RISING}}}{I_{UV-HYST}} = \frac{9\text{ V} \cdot \frac{1.45\text{ V} - 7\text{ V}}{1.5\text{ V}}}{5\text{ }\mu\text{A}} = 340\text{ k}\Omega \quad (36)$$

$$R_{UV2} = R_{UV1} \cdot \frac{V_{UV-RISING}}{V_{IN(on)} - V_{UV-RISING}} = 340\text{ k}\Omega \cdot \frac{1.5\text{ V}}{9\text{ V} - 1.5\text{ V}} = 68\text{ k}\Omega \quad (37)$$

### 8.2.2.3 Application Curves

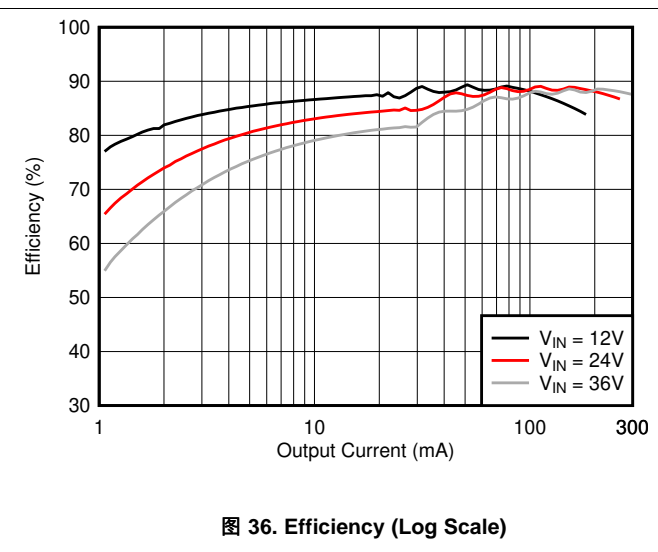
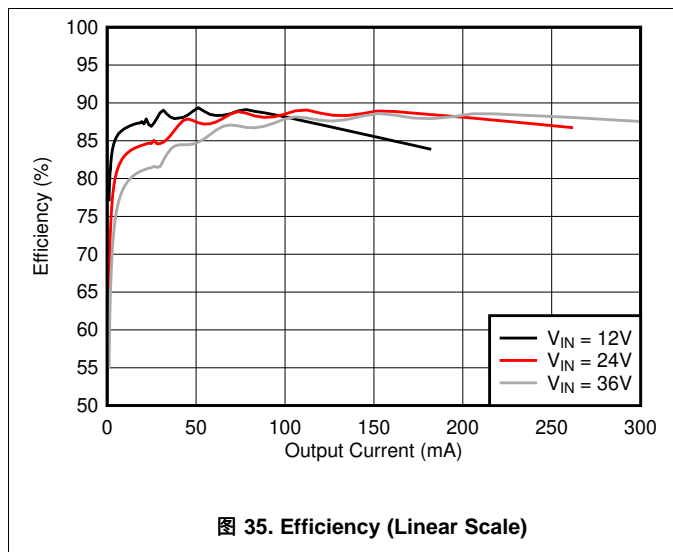

ADVANCE INFORMATION



图 37. Load Regulation (Linear Scale)



图 38. Load Regulation (Log Scale)

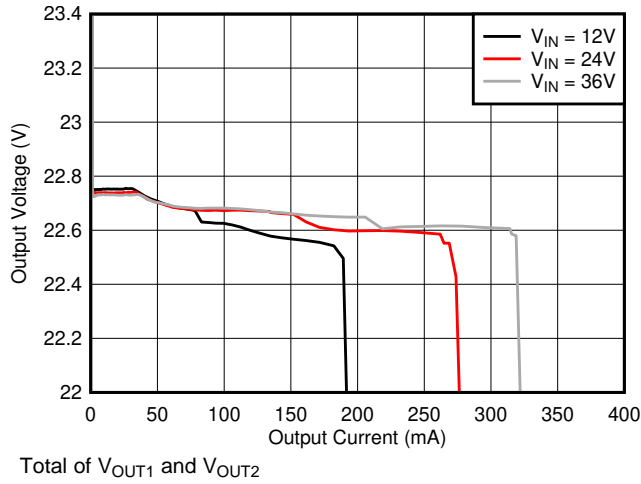

图 39. Start-Up Characteristic

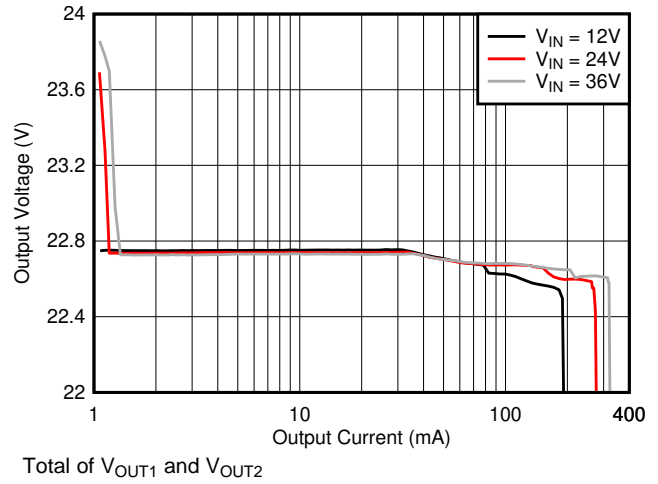

图 40. ENABLE ON Characteristic

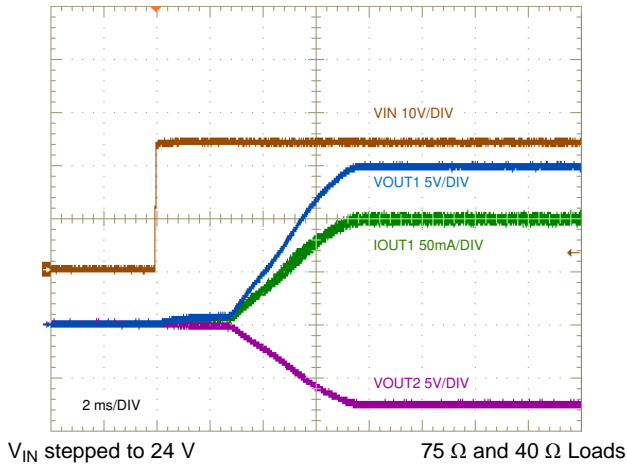

图 41. SW Node Voltage, Full Load

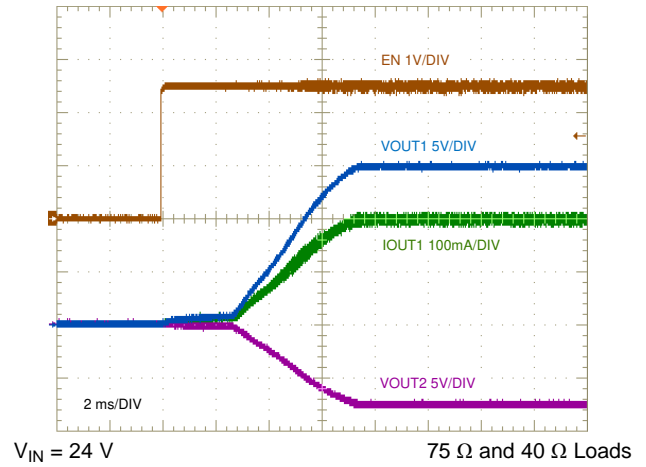

图 42. Flyback Diode Voltages, Full Load

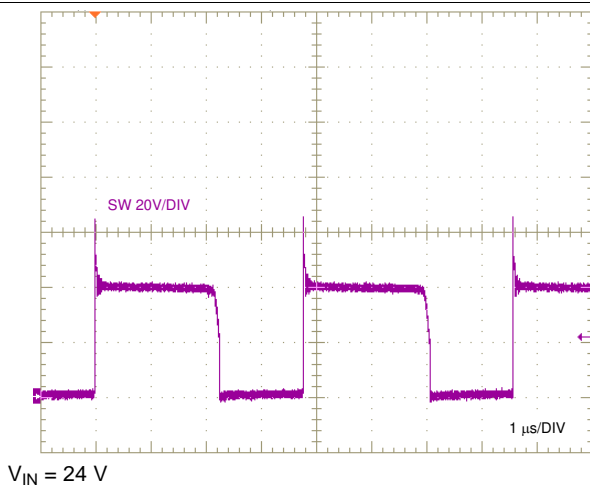

### 8.2.3 Design 3: PSR Flyback Converter With Stacked Dual Outputs of 24 V and 5 V

The schematic diagram of a dual-output flyback converter with high-voltage secondary stacked on the low-voltage secondary winding is given in 图 45. This configuration reduces the number of turns for the high-voltage output, resulting in lower secondary-to-secondary leakage inductance for improved output voltage cross regulation.

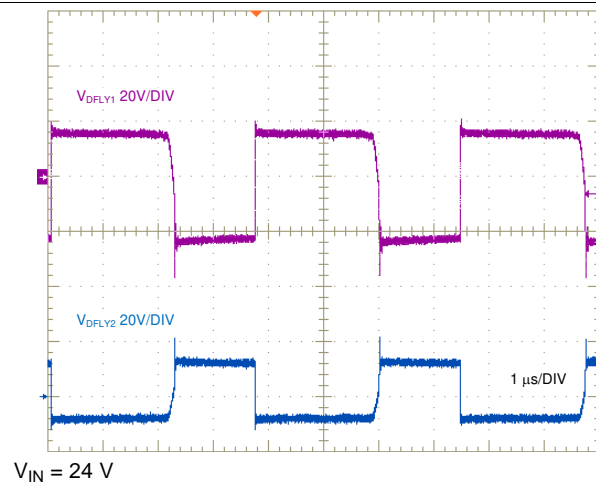
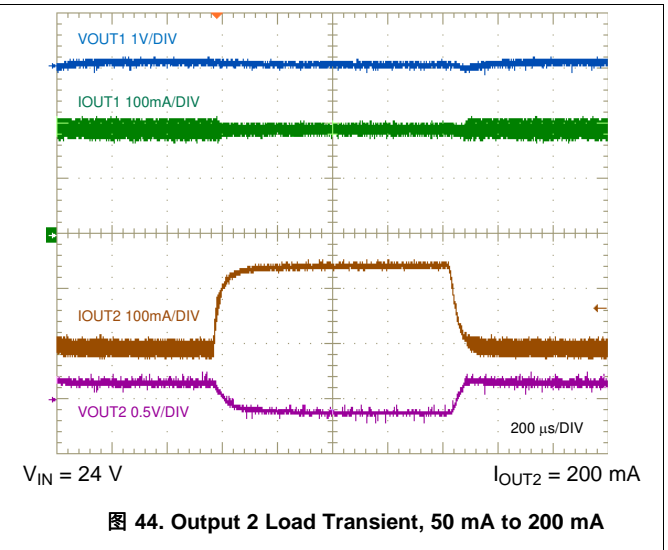
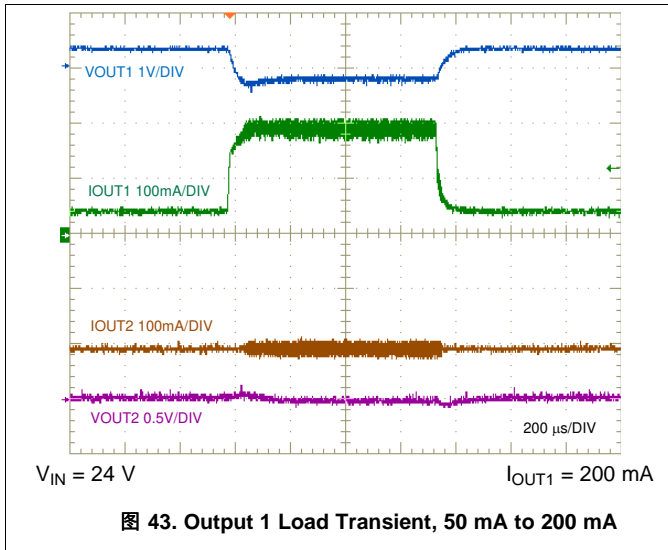

图 45. Schematic for Design 3 With  $V_{IN(nom)} = 24$  V,  $V_{OUT1} = 24$  V,  $V_{OUT2} = 5$  V

#### 8.2.3.1 Design Requirements

The required input, output, and performance parameters for this application example are shown in 表 5.

表 5. Design Parameters

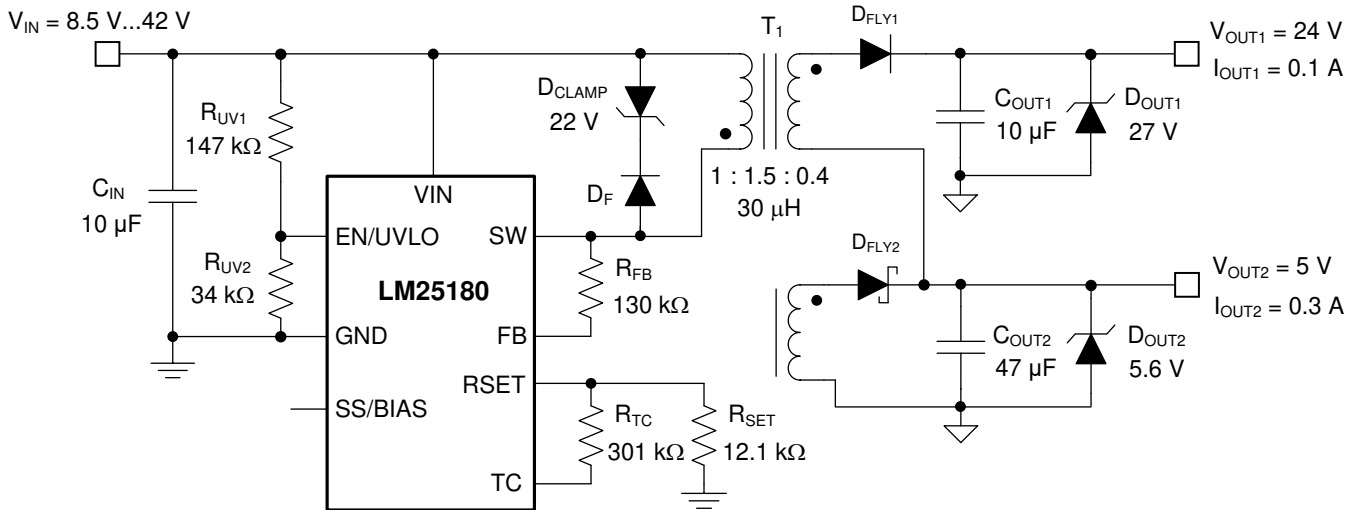
DESIGN PARAMETER	VALUE
Input voltage range (steady state)	8.5 V to 42 V
Output 1 voltage and current	24 V, 0.1 A
Output 2 voltage and current	5 V, 0.3 A
Input UVLO thresholds	8 V on, 7 V off
Output voltage regulation	$\pm 2\%$

The target full-load efficiency of this LM25180-Q1 design is 88% based on a nominal input voltage of 24 V and isolated output voltages of 24 V and 5 V. The selected flyback converter components are cited in 表 6, including multi-winding flyback transformer, input and output capacitors, rectifying diodes, and converter IC.

**表 6. List of Components for Design 3**

REF DES	QTY	SPECIFICATION	VENDOR	PART NUMBER
C <sub>IN</sub> , C <sub>OUT1</sub>	2	10 μF, 50 V, X7R, 1210, ceramic, AEC-Q200	Taiyo Yuden	UMJ325KB7106KMHT
		10 μF, 50 V, X7S, 1210, ceramic, AEC-Q200	TDK	CGA6P3X7S1H106M
C <sub>OUT2</sub>	1	47 μF, 10 V, X7R, 1210, ceramic, AEC-Q200	Murata	GCM32EC71A476KE02
D <sub>FLY1</sub>	1	Switching diode, fast recovery, 200 V, 1 A, SOD-123	DFLU1200	Diodes Inc.
D <sub>FLY2</sub>	1	Schottky diode, 40 V, 1 A, SOD-123	B140HW	Diodes Inc.
D <sub>CLAMP</sub>	1	Zener, 22 V, 1 W, PowerDI-123, AEC-Q101	DFLZ22-7	Diodes Inc.
D <sub>F</sub>	1	Switching diode, 75 V, 0.25 A, SOD-323	CMDD4448	Central Semi
D <sub>OUT1</sub>	1	Zener, 27 V, 2%, SOD-523, AEC-Q101	BZX585-B27	Nexperia
D <sub>OUT2</sub>	1	Zener, 5.6 V, 2%, SOD-523, AEC-Q101	BZX585-B5V6	Nexperia
R <sub>FB</sub>	1	130 kΩ, 1%, 0402	Std	Std
R <sub>SET</sub>	1	12.1 kΩ, 1%, 0402	Std	Std
R <sub>TC</sub>	1	301 kΩ, 1%, 0402	Std	Std
R <sub>UV1</sub>	1	147 kΩ, 1%, 0603	Std	Std
R <sub>UV2</sub>	1	34 kΩ, 1%, 0402	Std	Std
T <sub>1</sub>	1	30 μH, 2 A, turns ratio 1 : 1.5 : 0.4, 9 × 10 mm, SMT	Coilcraft	YA8864-BLD
		30 μH, 2 A, turns ratio 1 : 1 : 0.55, 9 × 10 mm, SMT	Coilcraft	YA8916-BLD
			Würth Elektronik	750317595
U <sub>1</sub>	1	LM25180-Q1 PSR flyback converter, AEC-Q100	Texas Instruments	LM25180QNGURQ1

### 8.2.3.2 Detailed Design Procedure

Components are selected based on the converter specifications using the LM25180-Q1 [quick-start calculator](#). The design procedure is similar to that outlined for Designs 1 and 2 previously.

#### 8.2.3.2.1 Flyback Transformer – T<sub>1</sub>

The 24-V output is DC stacked on top of the 5-V output as they share a common return connection. This enables lower secondary-to-secondary leakage inductance for better cross regulation and also reduced rectifier diode reverse voltage stress. Choose a primary-secondary turns ratio for the effective 19-V secondary based on an approximate 60% max duty cycle at minimum input voltage using [公式 38](#).

$$N_{PS} = \frac{D_{MAX}}{1 - D_{MAX}} \cdot \frac{V_{IN(min)}}{V_{OUT} + V_D} = \frac{0.6}{1 - 0.6} \cdot \frac{8.5 V}{19 V + 0.3 V} = 0.66 \quad (38)$$

Set the turns ratio of the transformer secondary windings using [公式 39](#). The transformer turns ratio for both outputs is thus specified as 1 : 1.5 : 0.4.

$$\frac{N_{S2}}{N_{S1}} = \frac{V_{OUT2} + V_{D2}}{V_{OUT1} + V_{D1}} = \frac{5 V + 0.3 V}{19 V + 0.3 V} = 0.275 \quad (39)$$

Select a magnetizing inductance based on the minimum off-time constraint using [公式 40](#). Choose a value of 30 μH with a saturation current of minimum 2 A for this application.

$$L_{MAG} \geq \frac{(V_{OUT1} + V_{D1}) \cdot N_{PS1} \cdot t_{OFF-MIN}}{I_{PRI-PK(FFM)}} = \frac{(19 V + 0.35 V) \cdot 0.66 \cdot 450 ns}{0.3 A} = 19.2 \mu H \quad (40)$$

#### 8.2.3.2.2 Feedback Resistor – R<sub>FB</sub>

Install a 130-kΩ resistor from SW to FB based on the secondary winding voltage (the sum of the 5-V output voltage and the Schottky diode forward voltage drop) reflected by the relevant transformer turns ratio, which in this design is 1 : 0.4 or 2.5 : 1.

$$R_{FB} = \frac{(V_{OUT} + V_D) \cdot N_{PS}}{0.1 mA} = \frac{(5 V + 0.25 V) \cdot 2.5}{0.1 mA} = 130 k\Omega \quad (41)$$

**8.2.3.2.3 UVLO Resistors –  $R_{UV1}$ ,  $R_{UV2}$**

Given  $V_{IN(on)}$  and  $V_{IN(off)}$  as the input voltage turn-on and turn-off thresholds of 8 V and 7 V, respectively, select the upper and lower UVLO resistors using the following expressions:

$$R_{UV1} = \frac{V_{IN(on)} \cdot \frac{V_{UV-FALLING}}{V_{UV-RISING}} - V_{IN(off)}}{I_{UV-HYST}} = \frac{8 \text{ V} \cdot \frac{1.45 \text{ V}}{1.5 \text{ V}} - 7 \text{ V}}{5 \mu\text{A}} = 147 \text{ k}\Omega \tag{42}$$

$$R_{UV2} = R_{UV1} \cdot \frac{V_{UV-RISING}}{V_{IN(on)} - V_{UV-RISING}} = 147 \text{ k}\Omega \cdot \frac{1.5 \text{ V}}{8 \text{ V} - 1.5 \text{ V}} = 34 \text{ k}\Omega \tag{43}$$

**8.2.3.3 Application Curves**

ADVANCE INFORMATION



图 46. Efficiency



$V_{IN}$  ramped to 24 V 240- $\Omega$  and 20- $\Omega$  Loads

图 47. Start-Up Characteristic

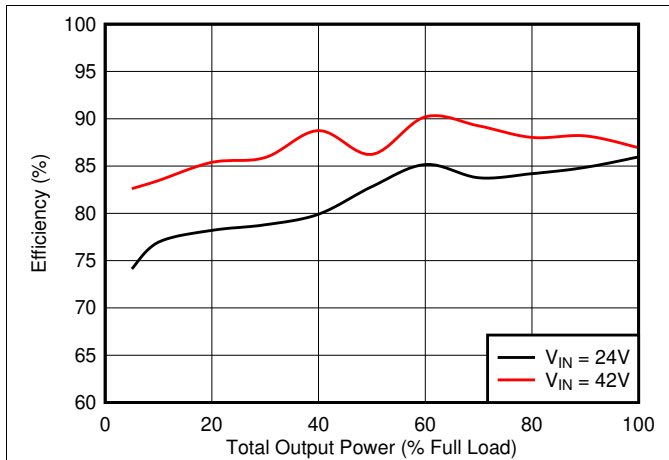
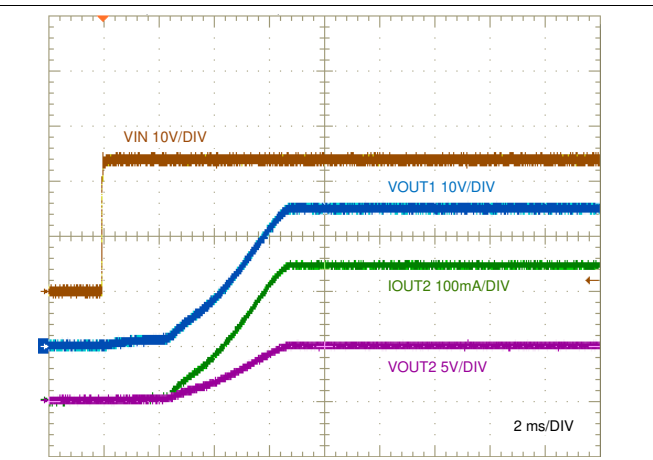
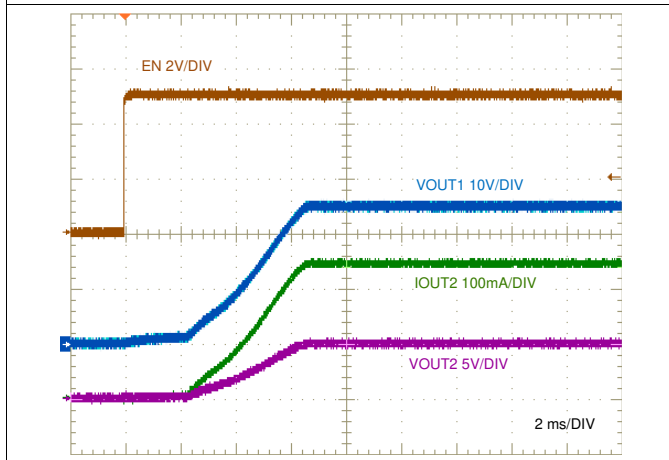

$V_{IN} = 24 \text{ V}$  240- $\Omega$  and 20- $\Omega$  Loads

图 48. ENABLE ON Characteristic

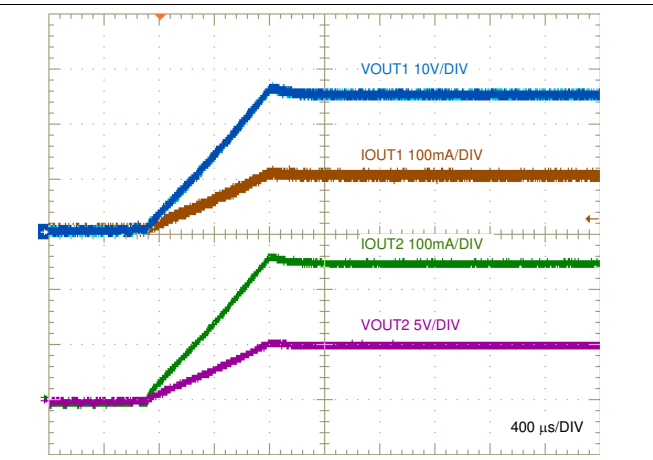

$V_{IN} = 24 \text{ V}$  240- $\Omega$  and 20- $\Omega$  Loads

图 49. Recovery From Short Circuit



图 50. SW Node Voltage, Full Load



图 51. Flyback Diode Voltages, Full Load

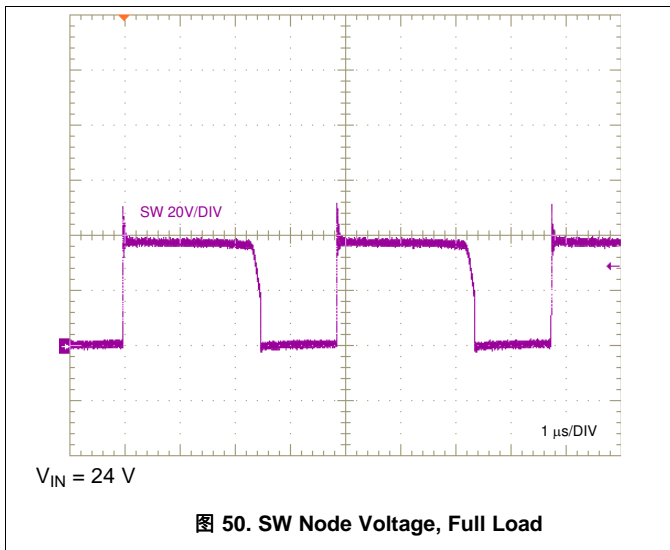

图 52. Output 1 Load Transient, 50 mA to 100 mA

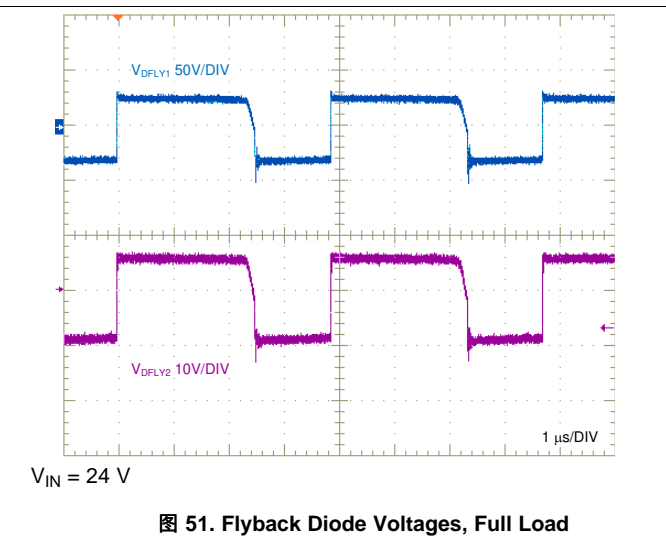

图 53. Output 2 Load Transient, 100 mA to 200 mA

ADVANCE INFORMATION

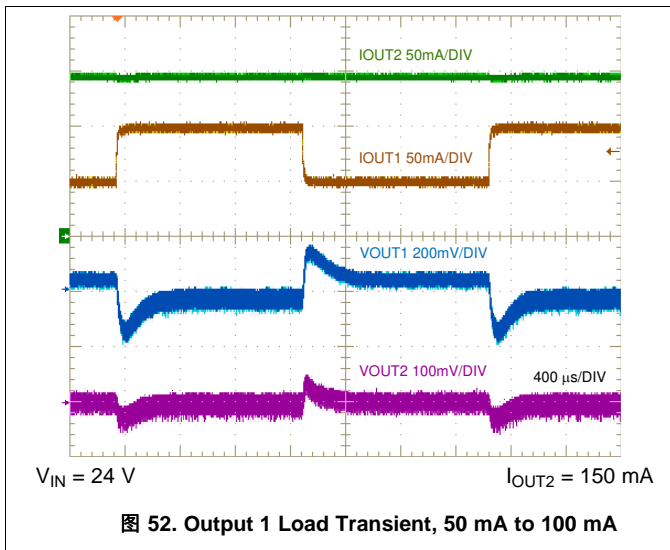
## 9 Power Supply Recommendations

The LM25180-Q1 flyback converter is designed to operate from a wide input voltage range from 4.5 V to 42 V. The characteristics of the input supply must be compatible with the [Specifications](#). In addition, the input supply must be capable of delivering the required input current to the fully-loaded regulator. Estimate the average input current with [公式 44](#).

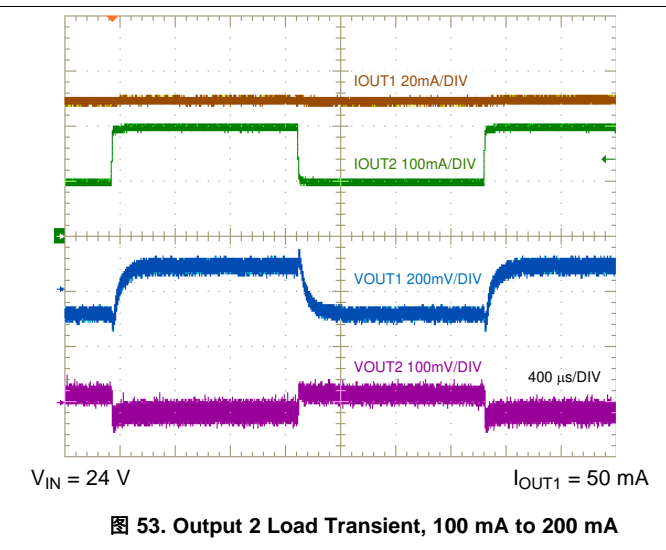
$$I_{IN} = \frac{V_{OUT} \cdot I_{OUT}}{V_{IN} \cdot \eta}$$

where

- $\eta$  is the efficiency (44)

If the converter is connected to an input supply through long wires or PCB traces with a large impedance, special care is required to achieve stable performance. The parasitic inductance and resistance of the input cables may have an adverse affect on converter operation. The parasitic inductance in combination with the low-ESR ceramic input capacitors form an underdamped resonant circuit. This circuit can cause overvoltage transients at VIN each time the input supply is cycled ON and OFF. The parasitic resistance causes the input voltage to dip during a load transient. If the regulator is operating close to the minimum input voltage, this dip can cause false UVLO fault triggering and a system reset. The best way to solve such issues is to reduce the distance from the input supply to the regulator and use an aluminum electrolytic input capacitor in parallel with the ceramics. The moderate ESR of the electrolytic capacitors helps to damp the input resonant circuit and reduce any voltage overshoots. A capacitance in the range of 10  $\mu$ F to 47  $\mu$ F is usually sufficient to provide input damping and helps to hold the input voltage steady during large load transients. A typical ESR of 0.25  $\Omega$  provides enough damping for most input circuit configurations.

An EMI input filter is often used in front of the regulator that, unless carefully designed, can lead to instability as well as some of the effects mentioned above. The application report [Simple Success with Conducted EMI for DC-DC Converters](#) provides helpful suggestions when designing an input filter for any switching regulator.

## 10 Layout

The performance of any switching converter depends as much upon PCB layout as it does the component selection. The following guidelines are provided to assist with designing a PCB with the best power conversion performance, thermal performance, and minimized generation of unwanted EMI. 图 54 and 图 55 provide layout examples for single-output and dual-output designs, respectively.

### 10.1 Layout Guidelines

PCB layout is a critical for good power supply design. There are several paths that conduct high slew-rate currents or voltages that can interact with transformer leakage inductance or parasitic capacitance to generate noise and EMI or degrade the power supply's performance.

1. Bypass the VIN pin to GND with a low-ESR ceramic capacitor, preferably of X7R or X7S dielectric. Place  $C_{IN}$  as close as possible to the LM25180-Q1 VIN and GND pins. Ground return paths for the input capacitor(s) must consist of localized top-side planes that connect to the GND pin and exposed PAD.
2. Minimize the loop area formed by the input capacitor connections and the VIN and GND pins.
3. Locate the transformer close to the SW pin. Minimize the area of the SW trace or plane to prevent excessive e-field or capacitive coupling.
4. Minimize the loop area formed by the diode-Zener clamp circuit connections and the primary winding terminals of the transformer.
5. Minimize the loop area formed by the flyback rectifying diode, output capacitor and the secondary winding terminals of the transformer.
6. Connect adequate copper at the cathode of the flyback diode to prevent overheating during overload or high ambient temperature conditions.
7. Tie the GND pin directly to the power pad under the device and to a heat-sinking PCB ground plane.
8. Use a ground plane in one of the middle layers as a noise shielding and heat dissipation path.
9. Have a single-point ground connection to the plane. Route the return connections for the reference resistor, soft-start, and enable components directly to the GND pin. This prevents any switched or load currents from flowing in analog ground traces. If not properly handled, poor grounding results in degraded load regulation or erratic output voltage ripple behavior.
10. Make  $V_{IN+}$ ,  $V_{OUT+}$  and ground bus connections short and wide. This reduces any voltage drops on the input or output paths of the converter and maximizes efficiency.
11. Minimize trace length to the FB pin. Locate the feedback resistor close to the FB pin.
12. Locate components  $R_{SET}$ ,  $R_{TC}$  and  $C_{SS}$  as close as possible to their respective pins. Route with minimal trace lengths.
13. Place a capacitor between input and output return connections to route common-mode noise currents directly back to their source.
14. Provide adequate heatsinking for the LM25180-Q1 to keep the junction temperature below 150°C. For operation at full rated load, the top-side ground plane is an important heat-dissipating area. Use an array of heat-sinking vias to connect the exposed PAD to the PCB ground plane. If the PCB has multiple copper layers, connect these thermal vias to inner-layer ground planes. The connection to  $V_{OUT+}$  provides heatsinking for the flyback diode.

10.2 Layout Examples



图 54. LM25180-Q1 Single-Output PCB Layout



图 55. LM25180-Q1 Dual-Output PCB Layout

ADVANCE INFORMATION

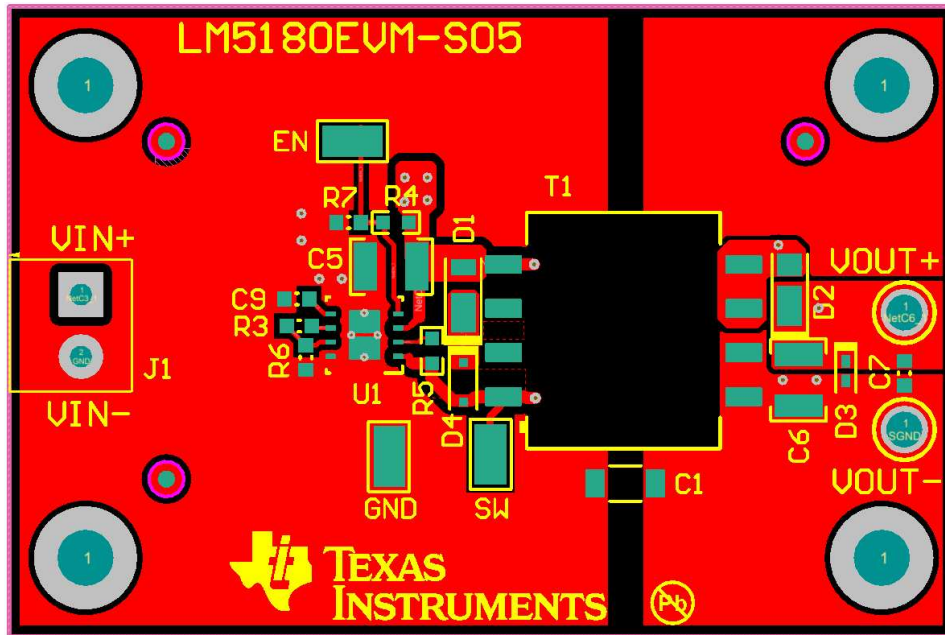
## 11 器件和文档支持

### 11.1 器件支持

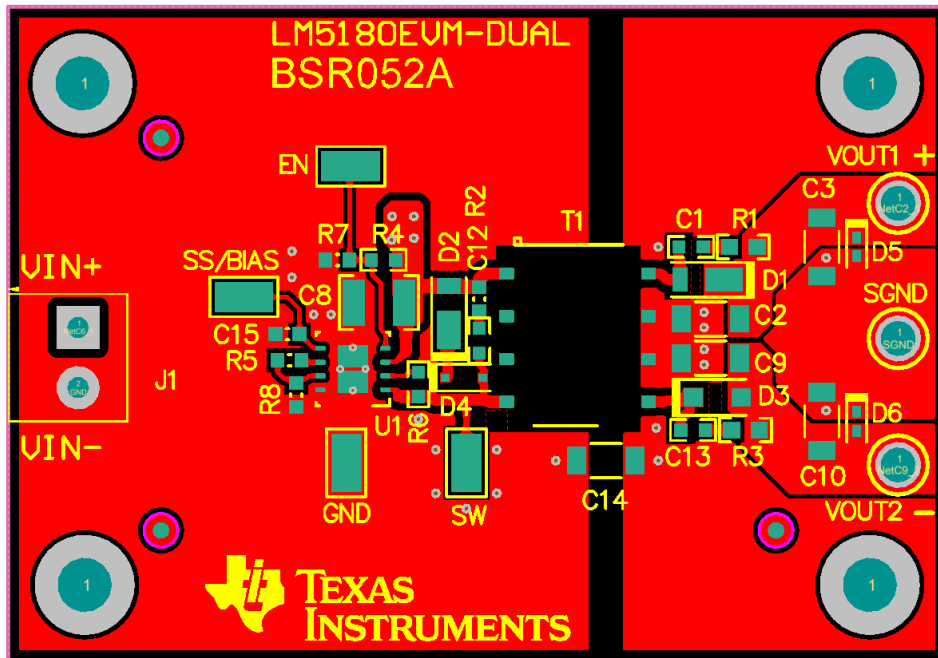
#### 11.1.1 第三方产品免责声明

TI 发布的与第三方产品或服务有关的信息，不能构成与此类产品或服务或保修的适用性有关的认可，不能构成此类产品或服务单独或与任何 TI 产品或服务一起的表示或认可。

#### 11.1.2 开发支持

相关开发支持，请参见以下文档：

- [LM25180-Q1 快速入门计算器](#)
- [LM25180-Q1 仿真模型](#)
- 有关 TI 的参考设计库，请访问 [TIDesigns](#)
- 有关 TI WEBENCH 设计环境，请访问 [WEBENCH® 设计中心](#)
- 要查看该产品的相关器件，请参阅 [LM5180-Q1](#)

#### 11.1.3 使用 WEBENCH® 工具定制设计方案

[单击此处](#)以使用带 WEBENCH® 电源设计器的 LM25180-Q1 器件来创建定制设计。

1. 首先输入输入电压 ( $V_{IN}$ )、输出电压 ( $V_{OUT}$ ) 和输出电流 ( $I_{OUT}$ ) 要求。
2. 使用优化器拨盘优化该设计的关键参数，如效率、尺寸和成本。
3. 将生成的设计与德州仪器 (TI) 的其他可行的解决方案进行比较。

WEBENCH 电源设计器可提供定制原理图以及罗列实时价格和组件供货情况的物料清单。

在多数情况下，可执行以下操作：

- 运行电气仿真，观察重要波形以及电路性能
- 运行热性能仿真，了解电路板热性能
- 将定制原理图和布局方案以常用 CAD 格式导出
- 打印设计方案的 PDF 报告并与同事共享

有关 WEBENCH 工具的详细信息，请访问 [www.ti.com.cn/WEBENCH](http://www.ti.com.cn/WEBENCH)。

### 11.2 文档支持

#### 11.2.1 相关文档

请参阅如下相关文档：

- [《LM5180EVM-S05 EVM 用户指南》\(SNVU592\)](#)
- [《LM5180EVM-DUAL EVM 用户指南》\(SNVU609\)](#)
- [《反激式 SMPS 设计内幕揭秘》\(SLUP261\)](#)
- [《反激式变压器设计在效率和 EMI 方面的注意事项》\(SLUP338\)](#)
- TI Designs:
  - [具有集成开关 PSR 反激式控制器的隔离式 IGBT 栅极驱动电源参考设计](#)
  - [适用于伺服驱动器的紧凑型、高效、24V 输入辅助电源参考设计](#)
  - [适用于电源隔离型超紧凑模拟输出模块的参考设计](#)
  - [具有 3 种 IGBT/SiC 偏置电源解决方案的 HEV/EV 牵引逆变器功率级参考设计](#)
  - [用于 IGBT/SiC 栅极驱动器且具有功率级的 4.5V 至 65V 输入、紧凑型偏置电源参考设计](#)
- TI 博客:
  - [反激式转换器：两个输入比一个输入好](#)
  - [为您的服务器 PSU 选择辅助电源时的常见挑战](#)
  - [在节省费用的同时最大程度地提高 PoE PD 效率](#)

## 文档支持 (接下页)

- 白皮书:
  - 《评估适用于成本驱动型严苛应用的宽 VIN、低 EMI 同步降压 电路》(SLYY104)
  - 《电源的传导 EMI 规格概述》(SLYY136)
  - 《电源的辐射 EMI 规格概述》(SLYY142)
- 《AN-2162: 轻松解决直流/直流转换器的传导 EMI 问题》(SNVA489)
- 《汽车启动仿真器用户指南》(SLVU984)
- 《使用新的热指标》(SBVA025)
- 《半导体和 IC 封装热指标》(SPRA953)

### 11.3 接收文档更新通知

要接收文档更新通知, 请转至 TI.com.cn 上的器件产品文件夹进行设置。单击右上角的通知我 进行注册, 即可接收产品信息更改每周摘要。有关更改的详细信息, 请查看任何已修订文档中包含的修订历史记录。

### 11.4 社区资源

The following links connect to TI community resources. Linked contents are provided "AS IS" by the respective contributors. They do not constitute TI specifications and do not necessarily reflect TI's views; see TI's [Terms of Use](#).

**TI E2E™ Online Community** *TI's Engineer-to-Engineer (E2E) Community.* Created to foster collaboration among engineers. At e2e.ti.com, you can ask questions, share knowledge, explore ideas and help solve problems with fellow engineers.

**Design Support** *TI's Design Support* Quickly find helpful E2E forums along with design support tools and contact information for technical support.

### 11.5 商标

E2E is a trademark of Texas Instruments.  
 WEBENCH is a registered trademark of Texas Instruments.  
 All other trademarks are the property of their respective owners.

### 11.6 静电放电警告



ESD 可能会损坏该集成电路。德州仪器 (TI) 建议通过适当的预防措施处理所有集成电路。如果不遵守正确的处理措施和安装程序, 可能会损坏集成电路。

ESD 的损坏小至导致微小的性能降级, 大至整个器件故障。精密的集成电路可能更容易受到损坏, 这是因为非常细微的参数更改都可能会导致器件与其发布的规格不相符。

### 11.7 Glossary

**SLYZ022** — *TI Glossary.*

This glossary lists and explains terms, acronyms, and definitions.

## 12 "机械、封装和可订购信息

以下页面具有机械、封装和可订购信息。这些信息是指定器件的最新可用数据。数据如有变更，恕不另行通知，且不会对此文档进行修订。如需获取此数据表的浏览器版本，请查阅左侧的导航栏。

NGU0008C



PACKAGE OUTLINE

WSO - 0.8 mm max height

PLASTIC SMALL OUTLINE - NO LEAD

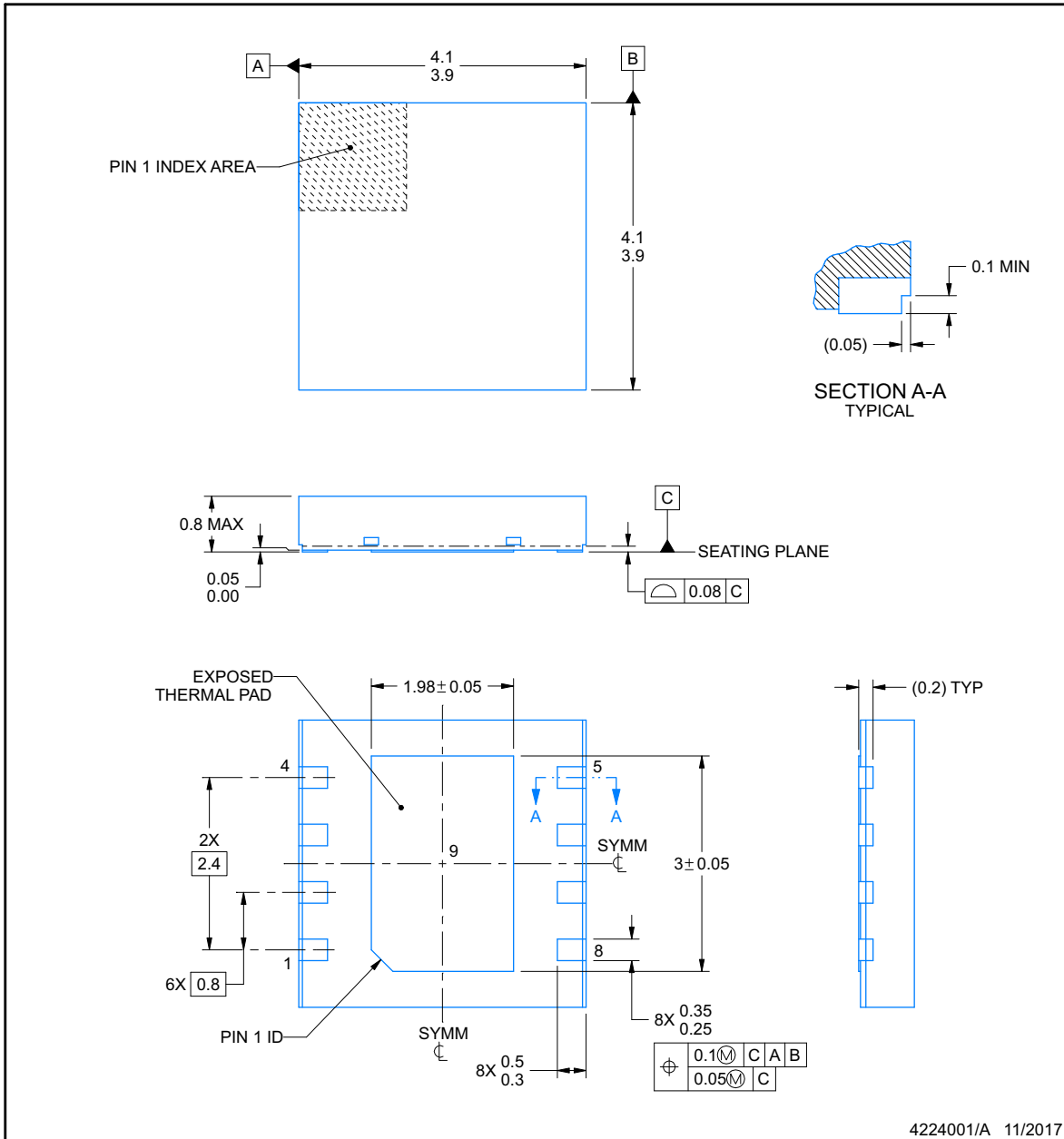

NOTES:

1. All linear dimensions are in millimeters. Any dimensions in parenthesis are for reference only. Dimensioning and tolerancing per ASME Y14.5M.
2. This drawing is subject to change without notice.
3. The package thermal pad must be soldered to the printed circuit board for thermal and mechanical performance.

## EXAMPLE BOARD LAYOUT

NGU0008C

WSON - 0.8 mm max height

PLASTIC SMALL OUTLINE - NO LEAD

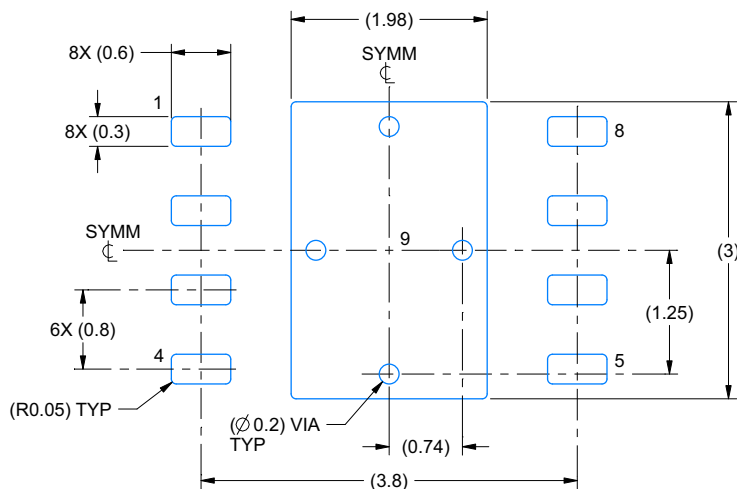

LAND PATTERN EXAMPLE  
EXPOSED METAL SHOWN  
SCALE:15X

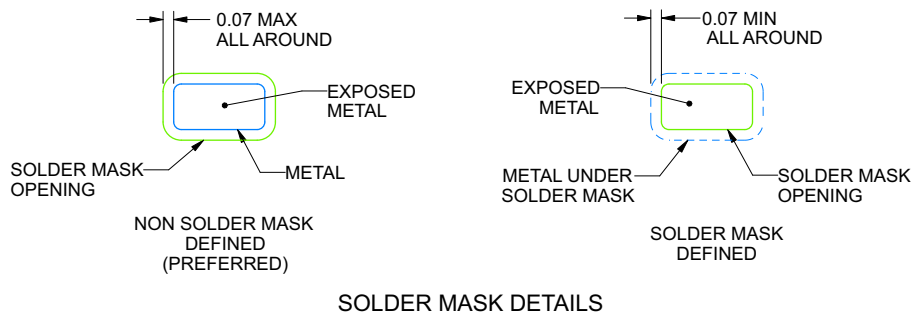

SOLDER MASK DETAILS

4224001/A 11/2017

NOTES: (continued)

- This package is designed to be soldered to a thermal pad on the board. For more information, see Texas Instruments literature number SLUA271 ([www.ti.com/lit/sluea271](http://www.ti.com/lit/sluea271)).
- Vias are optional depending on application, refer to device data sheet. If any vias are implemented, refer to their locations shown on this view. It is recommended that vias under paste be filled, plugged or tented.

ADVANCE INFORMATION

EXAMPLE STENCIL DESIGN

NGU0008C

WSON - 0.8 mm max height

PLASTIC SMALL OUTLINE - NO LEAD

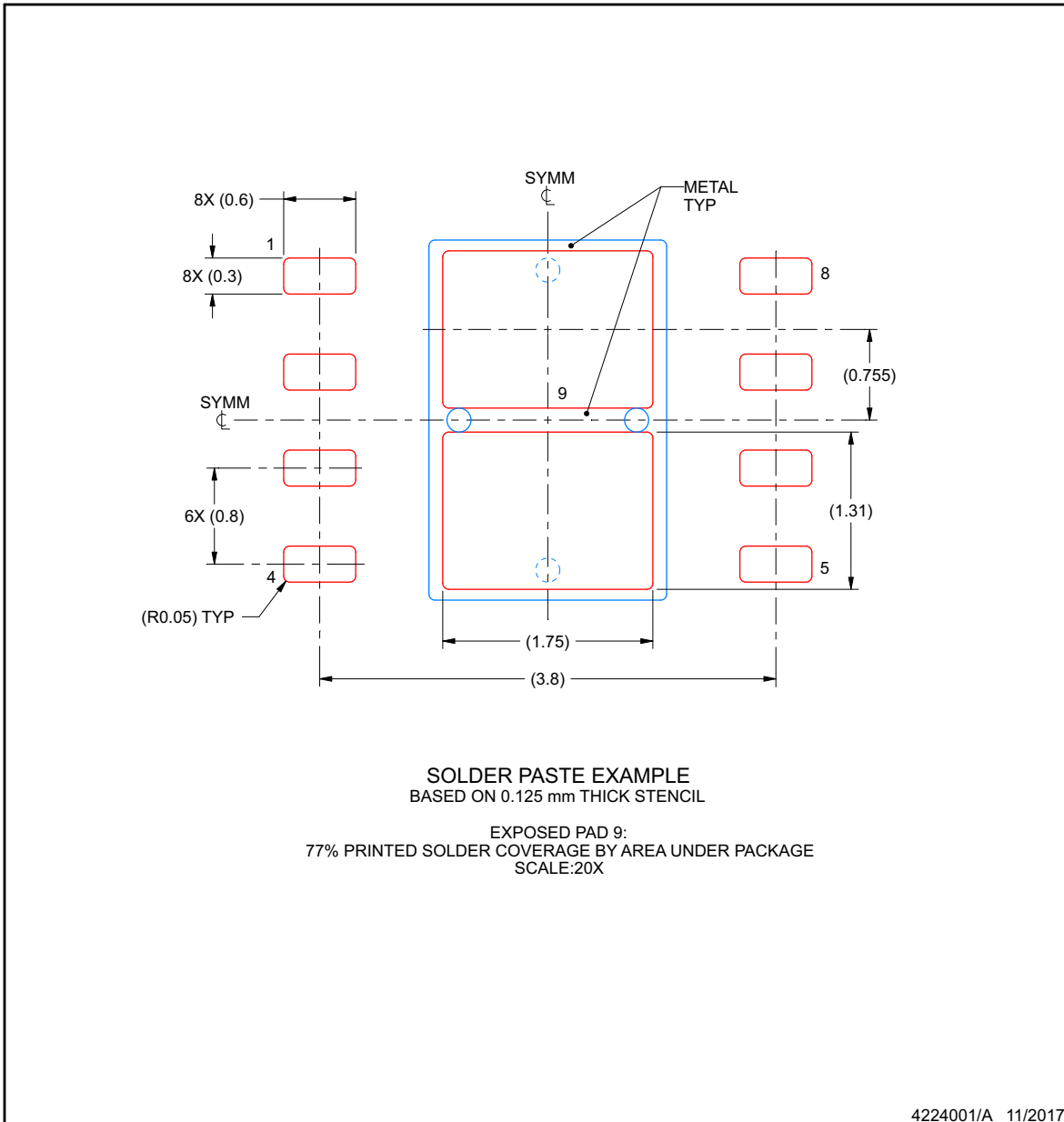

NOTES: (continued)

- 6. Laser cutting apertures with trapezoidal walls and rounded corners may offer better paste release. IPC-7525 may have alternate design recommendations.

## 重要声明和免责声明

TI 均以“原样”提供技术性及其可靠性数据（包括数据表）、设计资源（包括参考设计）、应用或其他设计建议、网络工具、安全信息和其他资源，不保证其中不含任何瑕疵，且不做任何明示或暗示的担保，包括但不限于对适销性、适合某特定用途或不侵犯任何第三方知识产权的暗示担保。

所述资源可供专业开发人员应用TI 产品进行设计使用。您将对以下行为独自承担全部责任：(1) 针对您的应用选择合适的TI 产品；(2) 设计、验证并测试您的应用；(3) 确保您的应用满足相应标准以及任何其他安全、安保或其他要求。所述资源如有变更，恕不另行通知。TI 对您使用所述资源的授权仅限于开发资源所涉及TI 产品的相关应用。除此之外不得复制或展示所述资源，也不提供其它TI 或任何第三方的知识产权授权许可。如因使用所述资源而产生任何索赔、赔偿、成本、损失及债务等，TI 对此概不负责，并且您须赔偿由此对TI 及其代表造成的损害。

TI 所提供产品均受TI 的销售条款 (<http://www.ti.com.cn/zh-cn/legal/termsofsale.html>) 以及ti.com.cn上或随附TI产品提供的其他可适用条款的约束。TI提供所述资源并不扩展或以其他方式更改TI 针对TI 产品所发布的可适用的担保范围或担保免责声明。

邮寄地址：上海市浦东新区世纪大道 1568 号中建大厦 32 楼，邮政编码：200122  
Copyright © 2019 德州仪器半导体技术（上海）有限公司

**PACKAGING INFORMATION**

Orderable Device	Status (1)	Package Type	Package Drawing	Pins	Package Qty	Eco Plan (2)	Lead finish/ Ball material (6)	MSL Peak Temp (3)	Op Temp (°C)	Device Marking (4/5)	Samples
LM25180QNGURQ1	ACTIVE	WSON	NGU	8	4500	RoHS & Green	SN	Level-2-260C-1 YEAR	-40 to 150	LM25180 QNGUQ1	

(1) The marketing status values are defined as follows:

**ACTIVE:** Product device recommended for new designs.

**LIFEBUY:** TI has announced that the device will be discontinued, and a lifetime-buy period is in effect.

**NRND:** Not recommended for new designs. Device is in production to support existing customers, but TI does not recommend using this part in a new design.

**PREVIEW:** Device has been announced but is not in production. Samples may or may not be available.

**OBsolete:** TI has discontinued the production of the device.

(2) **RoHS:** TI defines "RoHS" to mean semiconductor products that are compliant with the current EU RoHS requirements for all 10 RoHS substances, including the requirement that RoHS substance do not exceed 0.1% by weight in homogeneous materials. Where designed to be soldered at high temperatures, "RoHS" products are suitable for use in specified lead-free processes. TI may reference these types of products as "Pb-Free".

**RoHS Exempt:** TI defines "RoHS Exempt" to mean products that contain lead but are compliant with EU RoHS pursuant to a specific EU RoHS exemption.

**Green:** TI defines "Green" to mean the content of Chlorine (Cl) and Bromine (Br) based flame retardants meet JS709B low halogen requirements of <=100ppm threshold. Antimony trioxide based flame retardants must also meet the <=1000ppm threshold requirement.

(3) MSL, Peak Temp. - The Moisture Sensitivity Level rating according to the JEDEC industry standard classifications, and peak solder temperature.

(4) There may be additional marking, which relates to the logo, the lot trace code information, or the environmental category on the device.

(5) Multiple Device Markings will be inside parentheses. Only one Device Marking contained in parentheses and separated by a "~" will appear on a device. If a line is indented then it is a continuation of the previous line and the two combined represent the entire Device Marking for that device.

(6) Lead finish/Ball material - Orderable Devices may have multiple material finish options. Finish options are separated by a vertical ruled line. Lead finish/Ball material values may wrap to two lines if the finish value exceeds the maximum column width.

**Important Information and Disclaimer:**The information provided on this page represents TI's knowledge and belief as of the date that it is provided. TI bases its knowledge and belief on information provided by third parties, and makes no representation or warranty as to the accuracy of such information. Efforts are underway to better integrate information from third parties. TI has taken and continues to take reasonable steps to provide representative and accurate information but may not have conducted destructive testing or chemical analysis on incoming materials and chemicals. TI and TI suppliers consider certain information to be proprietary, and thus CAS numbers and other limited information may not be available for release.

In no event shall TI's liability arising out of such information exceed the total purchase price of the TI part(s) at issue in this document sold by TI to Customer on an annual basis.

## TAPE AND REEL INFORMATION

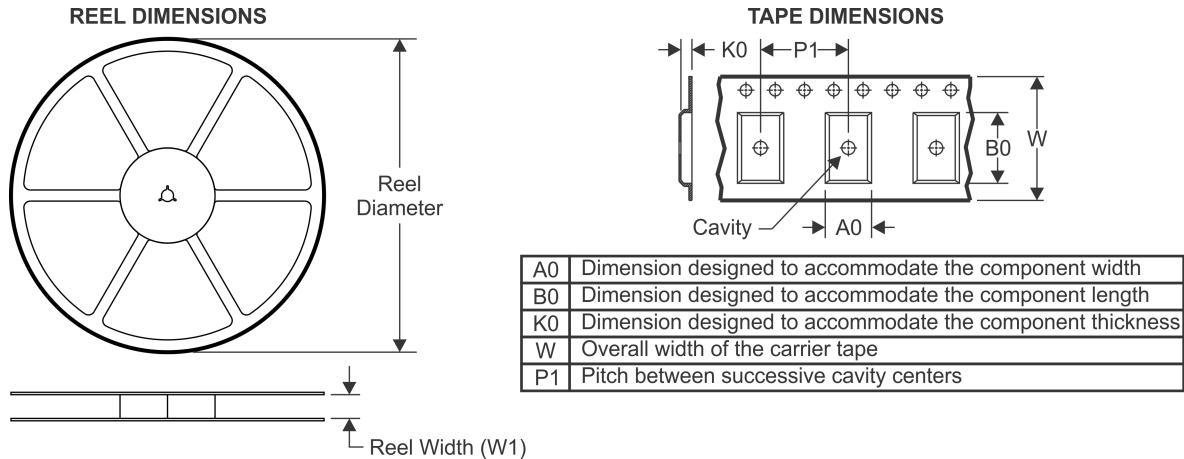

### QUADRANT ASSIGNMENTS FOR PIN 1 ORIENTATION IN TAPE

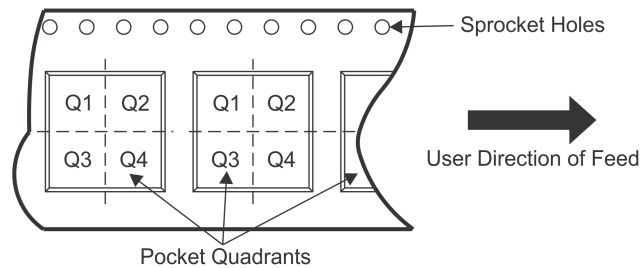

\*All dimensions are nominal

Device	Package Type	Package Drawing	Pins	SPQ	Reel Diameter (mm)	Reel Width W1 (mm)	A0 (mm)	B0 (mm)	K0 (mm)	P1 (mm)	W (mm)	Pin1 Quadrant
LM25180QNGURQ1	WSON	NGU	8	4500	330.0	12.4	4.3	4.3	1.1	8.0	12.0	Q1

TAPE AND REEL BOX DIMENSIONS

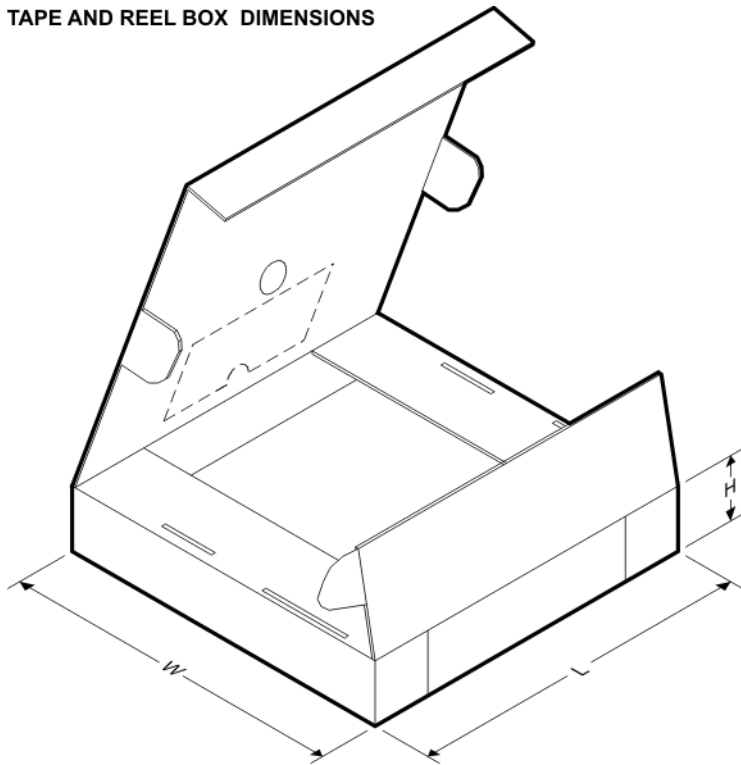

\*All dimensions are nominal

Device	Package Type	Package Drawing	Pins	SPQ	Length (mm)	Width (mm)	Height (mm)
LM25180QNGURQ1	WSON	NGU	8	4500	367.0	367.0	38.0

NGU0008B

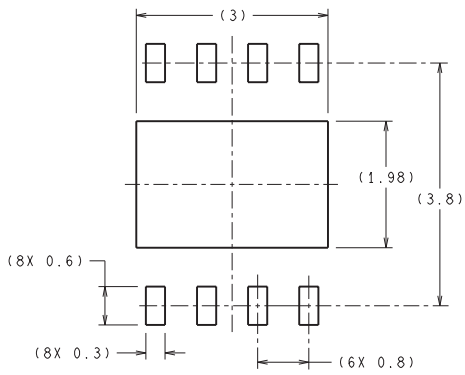

RECOMMENDED LAND PATTERN

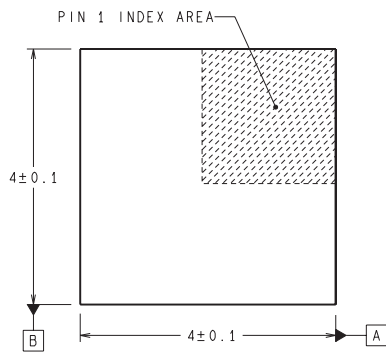

DIMENSIONS ARE IN MILLIMETERS  
DIMENSIONS IN ( ) FOR REFERENCE ONLY

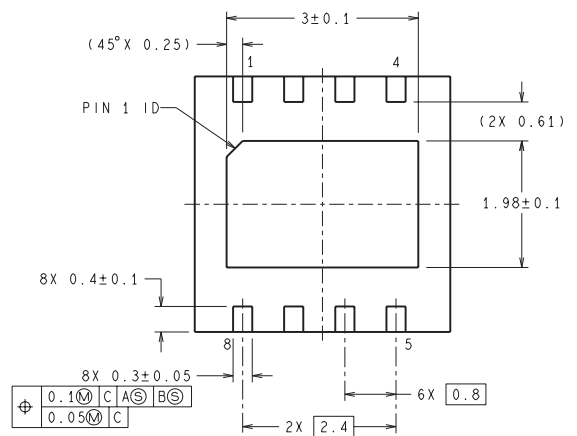
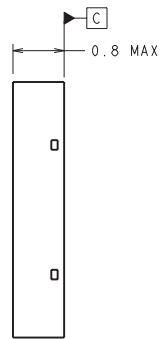
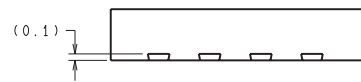

SDC08B (Rev A)

## 重要声明和免责声明

TI 提供技术和可靠性数据（包括数据表）、设计资源（包括参考设计）、应用或其他设计建议、网络工具、安全信息和其他资源，不保证没有瑕疵且不做任何明示或暗示的担保，包括但不限于对适销性、某特定用途方面的适用性或不侵犯任何第三方知识产权的暗示担保。

这些资源可供使用 TI 产品进行设计的熟练开发人员使用。您将自行承担以下全部责任：(1) 针对您的应用选择合适的 TI 产品，(2) 设计、验证并测试您的应用，(3) 确保您的应用满足相应标准以及任何其他安全、安保或其他要求。这些资源如有变更，恕不另行通知。TI 授权您仅可将这些资源用于研发本资源所述的 TI 产品的应用。严禁对这些资源进行其他复制或展示。您无权使用任何其他 TI 知识产权或任何第三方知识产权。您应全额赔偿因在这些资源的使用中对 TI 及其代表造成的任何索赔、损害、成本、损失和债务，TI 对此概不负责。

TI 提供的产品受 TI 的销售条款 (<https://www.ti.com.cn/zh-cn/legal/termsofsale.html>) 或 [ti.com.cn](https://www.ti.com.cn) 上其他适用条款/TI 产品随附的其他适用条款的约束。TI 提供这些资源并不会扩展或以其他方式更改 TI 针对 TI 产品发布的适用的担保或担保免责声明。

邮寄地址：上海市浦东新区世纪大道 1568 号中建大厦 32 楼，邮政编码：200122

Copyright © 2021 德州仪器半导体技术（上海）有限公司