

TPS380x-Q1 Voltage Detectors

1 Features

- Qualified for Automotive Applications
- Single Voltage Detector (TPS3803): Adjustable and 1.5 V
- Dual Voltage Detector (TPS3805): Adjustable and 3.3 V
- High $\pm 1.5\%$ Threshold Voltage Accuracy
- Supply Current: 3 μA Typical at $V_{\text{DD}} = 3.3 \text{ V}$
- Push/Pull Reset Output (TPS3805), Open-Drain Reset Output (TPS3803)
- Temperature Range: -40°C to 125°C
- 5-Pin SC-70 Package

2 Applications

- Applications Using DSPs, Microcontrollers, or Microprocessors
- Advanced Driver Assistance Systems
- Automotive Infotainment
- Automotive Cluster

3 Description

The TPS3803-Q1 and TPS3805-Q1 families of supervisory circuits provide circuit initialization and timing supervision, primarily for DSPs and processor-based systems.

The TPS3803G15-Q1 device has a fixed-sense threshold voltage V_{IT} set by an internal voltage divider, whereas the TPS3803-01-Q1 has an adjustable SENSE input that can be configured by two external resistors. In addition to the fixed sense threshold monitored at V_{DD} , the TPS3805-Q1 devices provide a second adjustable SENSE input. $\overline{\text{RESET}}$ is asserted in case either of the two voltages drops below V_{IT} .

During power on, $\overline{\text{RESET}}$ is asserted when supply voltage V_{DD} becomes higher than 0.8 V. Thereafter, the supervisory circuit monitors V_{DD} (and/or SENSE) and keeps $\overline{\text{RESET}}$ active as long as V_{DD} or SENSE remains below the threshold voltage V_{IT} . As soon as V_{DD} (SENSE) rises above the threshold voltage V_{IT} , $\overline{\text{RESET}}$ is deasserted again. The product spectrum is designed for 1.5-V, 3.3-V, and adjustable supply voltages.

The devices are available in a 5-pin SC-70 package. The TPS3803-Q1 and TPS3805-Q1 devices are characterized for operation over a temperature range of -40°C to 125°C .

Device Information⁽¹⁾

PART NUMBER	PACKAGE	BODY SIZE (NOM)
TPS3803-01-Q1	SC-70 (5)	2.00 mm x 1.25 mm
TPS3803G15-Q1		
TPS3805H33-Q1		

(1) For all available packages, see the orderable addendum at the end of the data sheet.

Typical Application Schematic

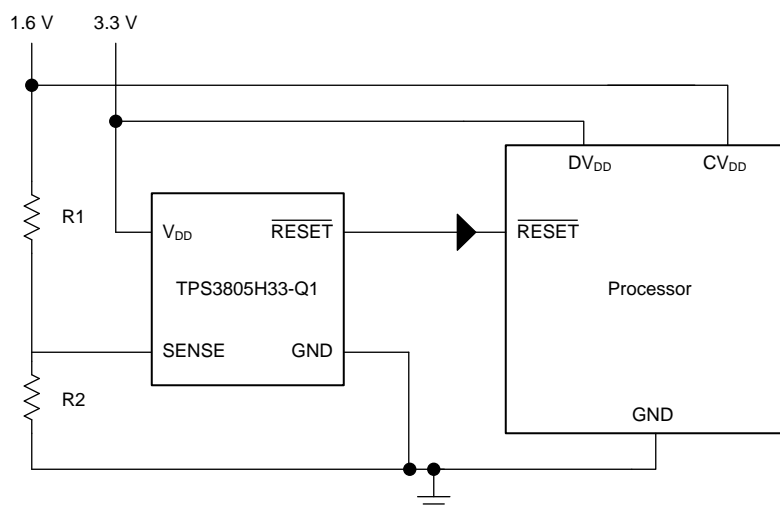

Table of Contents

1 Features	1	8.2 Functional Block Diagrams	9
2 Applications	1	8.3 Feature Description.....	9
3 Description	1	8.4 Device Functional Modes.....	11
4 Revision History	2	9 Application and Implementation	12
5 Device Comparison Table	3	9.1 Application Information.....	12
6 Pin Configuration and Functions	3	9.2 Typical Applications	12
7 Specifications	4	10 Power Supply Recommendations	14
7.1 Absolute Maximum Ratings	4	11 Layout	15
7.2 ESD Ratings	4	11.1 Layout Guidelines	15
7.3 Recommended Operating Conditions.....	4	11.2 Layout Examples.....	15
7.4 Thermal Information	4	12 Device and Documentation Support	17
7.5 Electrical Characteristics.....	5	12.1 Device Support	17
7.6 Timing Requirements.....	5	12.2 Related Links	17
7.7 Switching Characteristics.....	5	12.3 Community Resources.....	17
7.8 Dissipation Ratings	5	12.4 Trademarks	17
7.9 Typical Characteristics.....	7	12.5 Electrostatic Discharge Caution.....	17
8 Detailed Description	9	12.6 Glossary	17
8.1 Overview	9	13 Mechanical, Packaging, and Orderable Information	18

4 Revision History

NOTE: Page numbers for previous revisions may differ from page numbers in the current version.

Changes from Revision B (January 2008) to Revision C	Page
<ul style="list-style-type: none"> Added <i>Pin Configuration and Functions</i> section, <i>ESD Ratings</i> table, <i>Feature Description</i> section, <i>Device Functional Modes</i>, <i>Application and Implementation</i> section, <i>Power Supply Recommendations</i> section, <i>Layout</i> section, <i>Device and Documentation Support</i> section, and <i>Mechanical, Packaging, and Orderable Information</i> section 	1
<hr/>	
Changes from Revision A (June 2007) to Revision B	Page
<ul style="list-style-type: none"> Updated <i>Features</i> section 	1
<hr/>	
Changes from Original (December 2003) to Revision A	Page
<ul style="list-style-type: none"> Updated front page..... Changed Functional Block Diagram 	1 9

5 Device Comparison Table

DEVICE	THRESHOLD VOLTAGE		RESET OUTPUT TYPE
	V _{DD}	SENSE	
TPS3803-01-Q1	NA	1.226 V	Open-Drain
TPS3803G15-Q1	1.4 V	NA	Open-Drain
TPS3805H33-Q1	3.05 V	1.226 V	Push-Pull

6 Pin Configuration and Functions

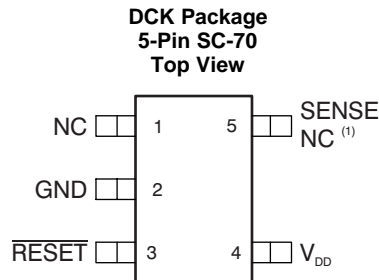

NC – No connection

(1) SENSE on TPS3803-01, TPS3805H33
NC on TPS3803G15

Pin Functions

PIN		I/O	DESCRIPTION
NAME	NO.		
GND	2	I	Ground
RESET	3	O	Active-low reset output (TPS3803-Q1: open drain, TPS3805-Q1: push/pull)
SENSE	5	I	Adjustable sense input
NC	1	—	No internal connection
NC (TPS3803G15-Q1)	5	—	No internal connection
V _{DD}	4	I	Input supply voltage, fixed sense input for TPS3803G15-Q1 and TPS3805-Q1

7 Specifications

7.1 Absolute Maximum Ratings

over operating free-air temperature range (unless otherwise noted)⁽¹⁾

		MIN	MAX	UNIT
V _{DD}	Supply voltage ⁽²⁾	7	7	V
	Voltage applied to all other pins ⁽²⁾	-0.3	7	V
I _{OL}	Maximum low-level output current		5	mA
I _{OH}	Maximum high-level output current		-5	mA
I _{IK}	Input clamp current	V _I < 0 or V _I > V _{DD}	±10	mA
I _{OK}	Output clamp current	V _O < 0 or V _O > V _{DD}	±10	mA
P _D	Continuous total power dissipation	See Dissipation Ratings		
T _A	Operating free-air temperature	-40	125	°C
T _{solder}	Soldering temperature		260	°C
T _{stg}	Storage temperature	-65	150	°C

- (1) Stresses beyond those listed under *Absolute Maximum Ratings* may cause permanent damage to the device. These are stress ratings only, and functional operation of the device at these or any other conditions beyond those indicated under *Recommended Operating Conditions* is not implied. Exposure to absolute-maximum-rated conditions for extended periods may affect device reliability.
- (2) All voltage values are with respect to GND. For reliable operation, the device should not be continuously operated at 7 V for more than t = 1000 h.

7.2 ESD Ratings

		VALUE	UNIT
V _(ESD)	Electrostatic discharge	Human body model (HBM), per AEC Q100-002 ⁽¹⁾	±2000
		Charged-device model (CDM), per AEC Q100-011	±1000

- (1) AEC Q100-002 indicates that HBM stressing shall be in accordance with the ANSI/ESDA/JEDEC JS-001 specification.

7.3 Recommended Operating Conditions

		MIN	MAX	UNIT
V _{DD}	Supply voltage	1.3	6	V
V _I	Input voltage	0	V _{DD} + 0.3	V
T _A	Operating free-air temperature	-40	125	°C

7.4 Thermal Information

THERMAL METRIC ⁽¹⁾		TPS3803x-Q1 TPS3805x-Q1	UNIT
		DCK (SC-70)	
		5 PINS	
R _{θJA}	Junction-to-ambient thermal resistance	246.6	°C/W
R _{θJC(top)}	Junction-to-case (top) thermal resistance	68.2	°C/W
R _{θJB}	Junction-to-board thermal resistance	78.4	°C/W
ψ _{JT}	Junction-to-top characterization parameter	0.9	°C/W
ψ _{JB}	Junction-to-board characterization parameter	77.7	°C/W
R _{θJC(bot)}	Junction-to-case (bottom) thermal resistance	N/A	°C/W

- (1) For more information about traditional and new thermal metrics, see the *Semiconductor and IC Package Thermal Metrics* application report, [SPRA953](#).

7.5 Electrical Characteristics

over operating free-air temperature range (unless otherwise noted)

PARAMETER		TEST CONDITIONS	MIN	TYP	MAX	UNIT	
V _{OH}	High-level output voltage (TPS3805 only)	V _{DD} = 1.5 V, I _{OH} = -0.5 mA	0.8 × V _{DD}			V	
		V _{DD} = 3.3 V, I _{OH} = -1 mA					
		V _{DD} = 6 V, I _{OH} = -1.5 mA					
V _{OL}	Low-level output voltage	V _{DD} = 1.5 V, I _{OL} = 1 mA			0.3	V	
		V _{DD} = 3.3 V, I _{OL} = 2 mA					
		V _{DD} = 6 V, I _{OL} = 3 mA					
Power-up reset voltage ⁽¹⁾		V _{IT} > 1.5 V, T _A = 25°C	0.8			V	
		V _{IT} ≤ 1.5 V, T _A = 25°C	1				
V _{IT}	Negative-going input threshold voltage ⁽²⁾	SENSE	1.2	1.226	1.244	V	
		TPS3803G15	1.379	1.4	1.421		
		TPS3805H33	3.004	3.05	3.096		
V _{hys}	Hysteresis	1.2 V < V _{IT} < 2.5 V	15			mV	
		2.5 V < V _{IT} < 3.5 V	30				
I _I	Input current	SENSE	-25		25	nA	
I _{OH}	High-level output current at RESET	Open drain only	V _{DD} = V _{IT} + 0.2 V, V _{OH} = V _{DD}		300	nA	
I _{DD}	Supply current	TPS3803-01	V _{DD} = 3.3 V, Output unconnected		2	4	μA
		TPS3805, TPS3803G15			3	5	
		TPS3803-01	V _{DD} = 6 V, Output unconnected		2	4	
		TPS3805, TPS3803G15			4	6	
C _I	Input capacitance	V _I = 0 V to V _{DD}		1	pF		

 (1) The lowest supply voltage at which $\overline{\text{RESET}}$ (V_{OL(max)} = 0.2 V, I_{OL} = 50 μA) becomes active. t_r(V_{DD}) ≥ 15 μs/V.

(2) To ensure the best stability of the threshold voltage, place a bypass capacitor (ceramic, 0.1-μF) near the supply terminals.

7.6 Timing Requirements

 R_L = 1 MΩ, C_L = 50 pF, T_A = -40°C to 125°C (unless otherwise noted)

			MIN	MAX	UNIT
t _w	Pulse duration	V _{DD}	5.5		μs
		SENSE			
			V _{IH} = 1.05 × V _{IT} , V _{IL} = 0.95 × V _{IT}		

7.7 Switching Characteristics

 R_L = 1 MΩ, C_L = 50 pF, T_A = -40°C to 125°C (unless otherwise noted)

PARAMETER		TEST CONDITIONS	MIN	TYP	MAX	UNIT
t _{PHL}	Propagation (delay) time, high-to-low-level output	V _{DD} to $\overline{\text{RESET}}$ delay	V _{IH} = 1.05 × V _{IT} , V _{IL} = 0.95 × V _{IT}		5	100
		SENSE to $\overline{\text{RESET}}$ delay				
t _{PLH}	Propagation (delay) time, low-to-high-level output	V _{DD} to $\overline{\text{RESET}}$ delay	V _{IH} = 1.05 × V _{IT} , V _{IL} = 0.95 × V _{IT}		5	100
		SENSE to $\overline{\text{RESET}}$ delay μA				

7.8 Dissipation Ratings

PACKAGE	POWER RATING T _A < 25°C	DERATING FACTOR ABOVE T _A = 25°C	POWER RATING T _A = 70°C	POWER RATING T _A = 85°C
DCK	321 mW	2.6 mW/°C	206 mW	167 mW

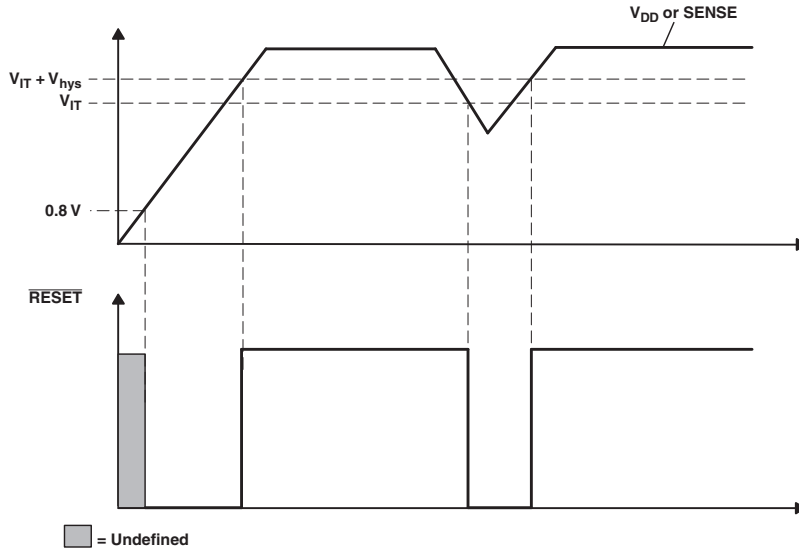

Figure 1. Timing Requirements

7.9 Typical Characteristics

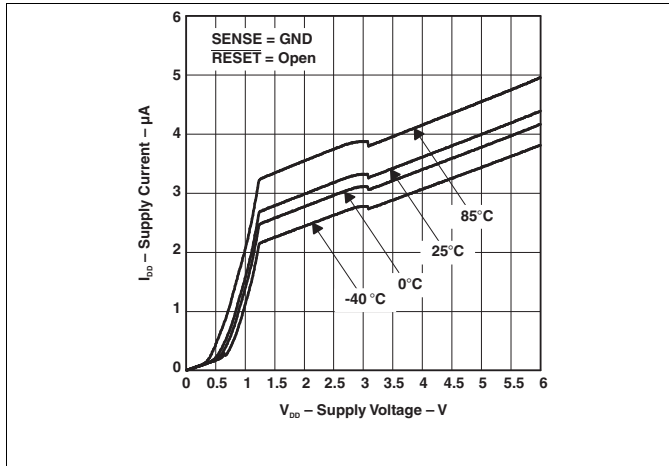

Figure 2. TPS3805H33-Q1 Supply Current vs Supply Voltage

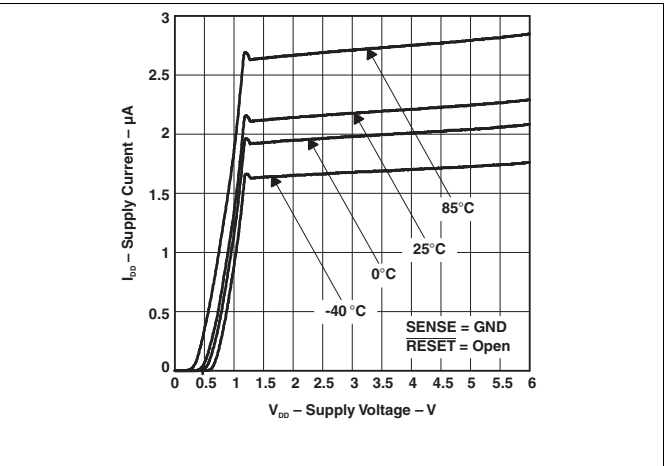

Figure 3. TPS3803-01-Q1 Supply Current vs Supply Voltage

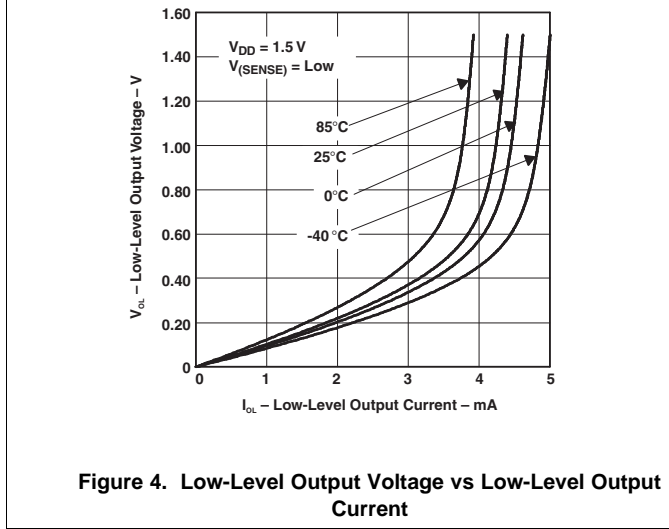

Figure 4. Low-Level Output Voltage vs Low-Level Output Current

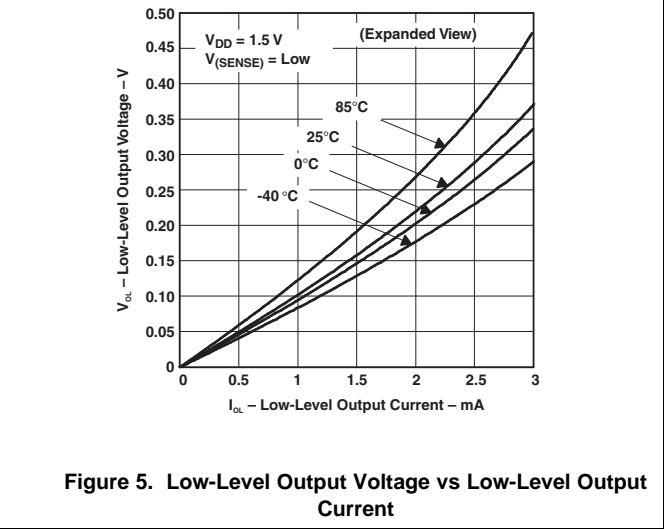

Figure 5. Low-Level Output Voltage vs Low-Level Output Current

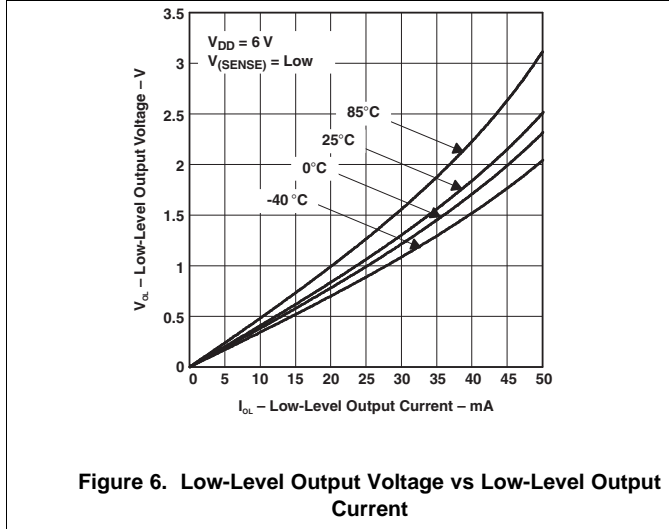

Figure 6. Low-Level Output Voltage vs Low-Level Output Current

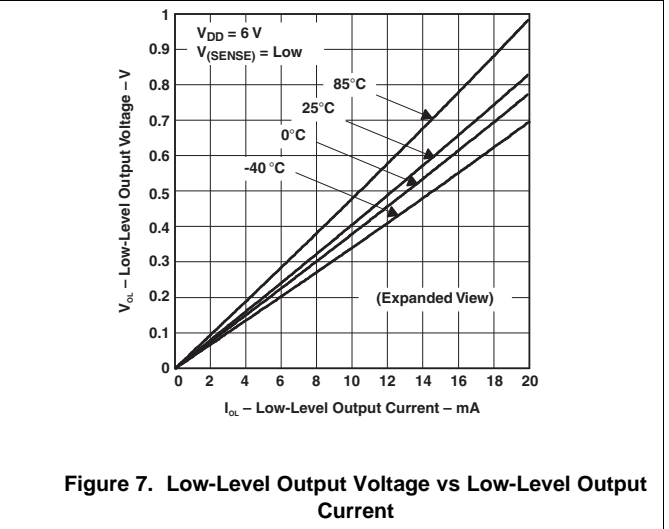

Figure 7. Low-Level Output Voltage vs Low-Level Output Current

Typical Characteristics (continued)

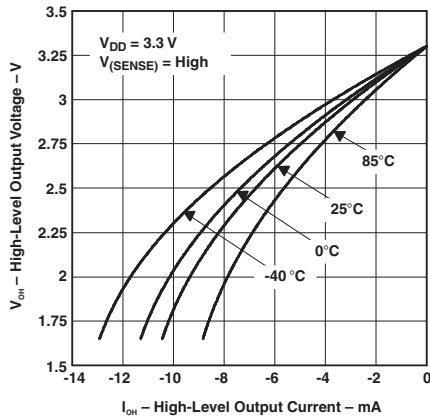

Figure 8. TPS3805H33-Q1 High-Level Output Voltage vs High-Level Output Current

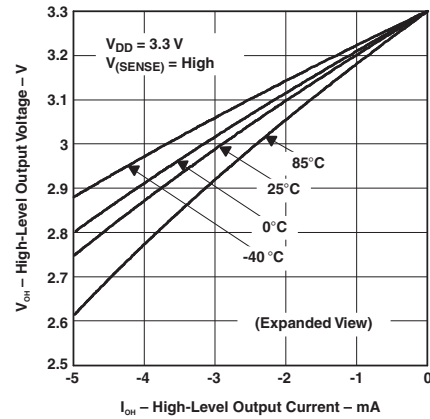

Figure 9. TPS3805H33-Q1 High-Level Output Voltage vs High-Level Output Current

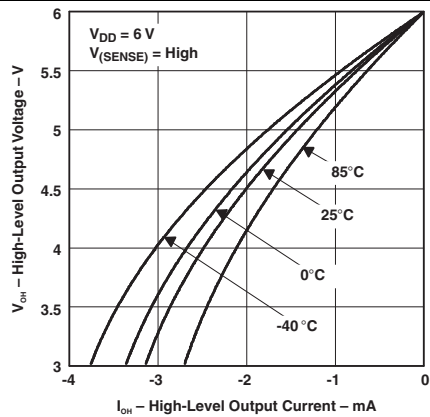

Figure 10. TPS3805H33-Q1 High-Level Output Voltage vs High-Level Output Current

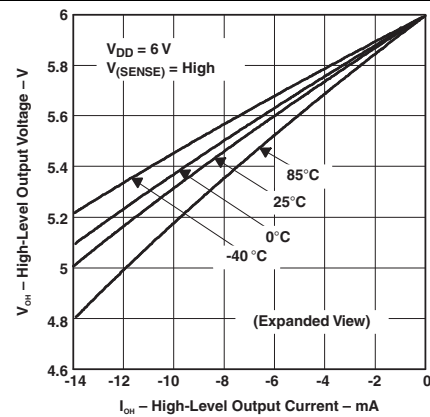

Figure 11. TPS3805H33-Q1 High-Level Output Voltage vs High-Level Output Current

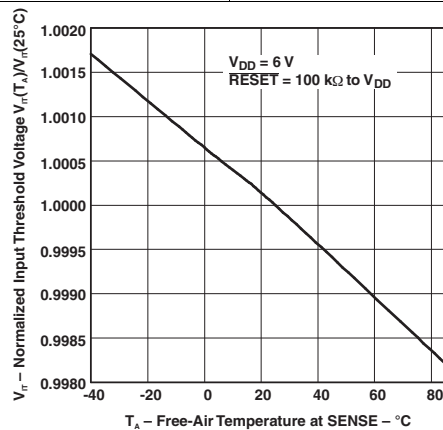

Figure 12. TPS3803-01-Q1 Normalized Input Threshold Voltage vs Free-Air Temperature At Sense

8 Detailed Description

8.1 Overview

The TPS380x-Q1 devices are low-current supervisory circuits used to monitor system voltages above 1.226 V. The devices assert an active low $\overline{\text{RESET}}$ signal when V_{DD} , SENSE, or both voltages drop below a preset threshold. The $\overline{\text{RESET}}$ output remains low until the V_{DD} , SENSE, or both voltages return above their thresholds. The devices are also designed to be immune to short negative transients on the V_{DD} and SENSE pins.

8.2 Functional Block Diagrams

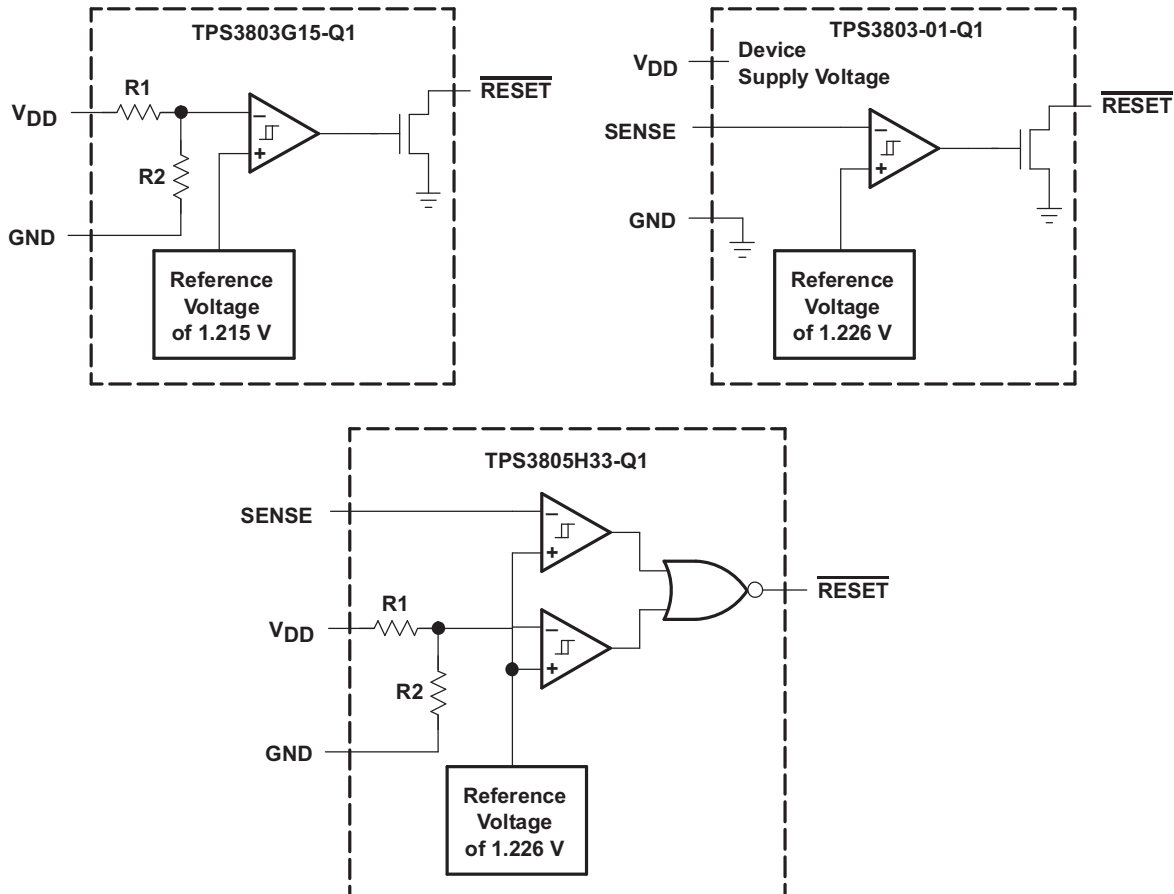

8.3 Feature Description

8.3.1 V_{DD} and SENSE Monitoring

The V_{DD} and SENSE inputs provide a pin at which a system voltage can be monitored. If the voltage on this pin drops below V_{IT} , $\overline{\text{RESET}}$ is asserted low. The comparator has a built-in hysteresis to ensure smooth $\overline{\text{RESET}}$ assertions and de-assertions. Refer to the [Device Comparison Table](#) to determine the V_{DD} and SENSE voltage thresholds for each device. The adjustable version TPS3803-01-Q1 can be used to monitor any voltage rail down to 1.226 V using the circuit shown in [Figure 13](#), where V_{IT} ' is the V_{in} threshold voltage.

Feature Description (continued)

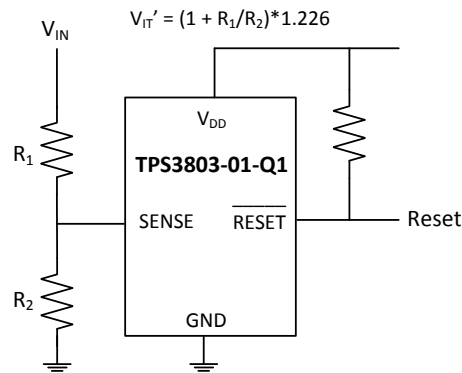

Figure 13. Using Adjustable Version

8.3.2 Transient Immunity

The TPS380x-Q1 devices are immune to short negative transients on the V_{DD} and SENSE pins. Sensitivity to transients is dependent on threshold overdrive as shown in Figure 15 and Figure 16. These graphs show the duration that the transient is below V_{IT} compared to the magnitude of the voltage drop below V_{IT} , called the threshold overdrive voltage. Any combination of transient duration and overdrive voltage which lies above the curves will result in $\overline{\text{RESET}}$ being asserted low. Any transient which lies below the curves will be ignored by the device.

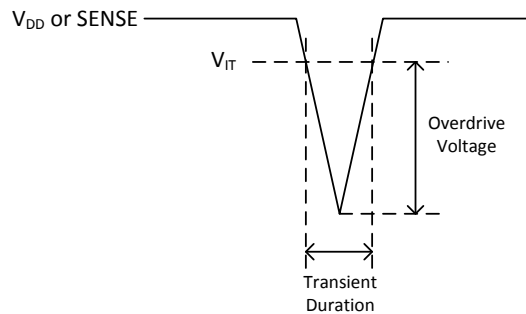
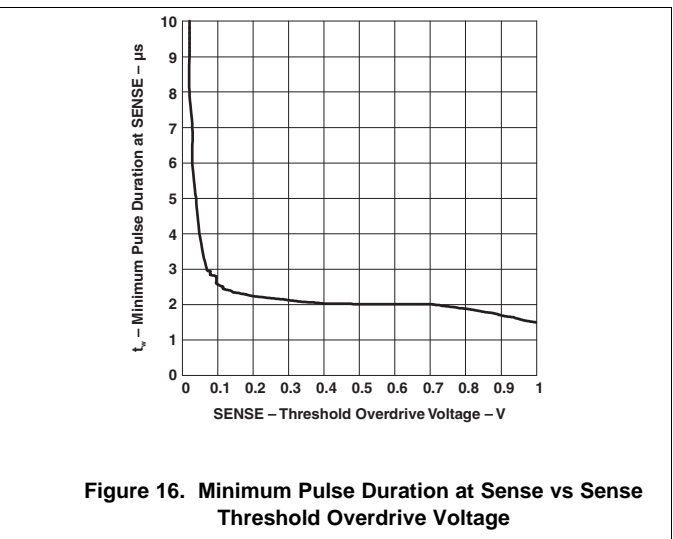
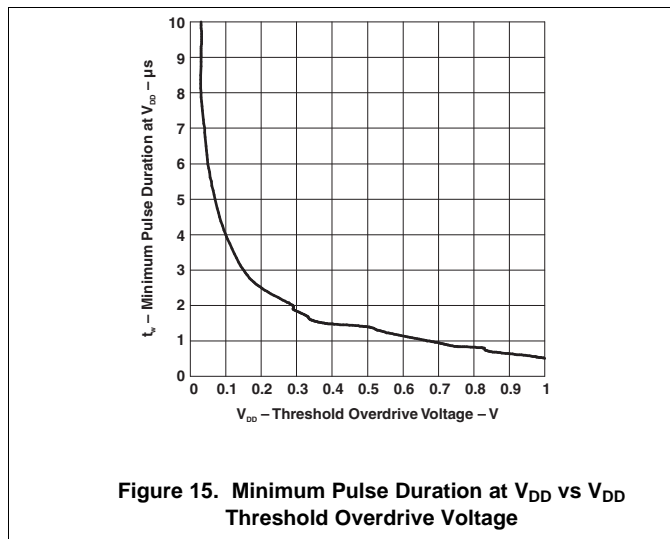

Figure 14. Overdrive Voltage



8.4 Device Functional Modes

TPS3803-01-Q1 and TPS3803G15-Q1 monitor only one supply, which is SENSE and V_{DD} respectively. When that supply is above the V_{IT} threshold, $\overline{\text{RESET}}$ will be high. Otherwise, $\overline{\text{RESET}}$ will be low. TPS3805H33-Q1 monitors both V_{DD} and SENSE. When both V_{DD} and SENSE are above the V_{IT} threshold, $\overline{\text{RESET}}$ will be high. Otherwise, $\overline{\text{RESET}}$ will be low.

Table 1. Function and Truth Table

TPS3803-01-Q1	
SENSE > V_{IT}	$\overline{\text{RESET}}$
0	L
1	H

Table 2. Function and Truth Table

TPS3803G15-Q1	
V_{DD} > V_{IT}	$\overline{\text{RESET}}$
0	L
1	H

Table 3. Function and Truth Table

TPS3805H33-Q1		
V_{DD} > V_{IT}	SENSE > V_{IT}	$\overline{\text{RESET}}$
0	0	L
0	1	L
1	0	L
1	1	H

9 Application and Implementation

NOTE

Information in the following applications sections is not part of the TI component specification, and TI does not warrant its accuracy or completeness. TI's customers are responsible for determining suitability of components for their purposes. Customers should validate and test their design implementation to confirm system functionality.

9.1 Application Information

The TPS380x-Q1 voltage supervisor devices are designed to assert an active-low $\overline{\text{RESET}}$ signal when V_{DD} and/or SENSE drop below a voltage threshold V_{IT} . The $\overline{\text{RESET}}$ signal remains low until the voltages return above their respective thresholds. The TPS3803G15-Q1 and TPS3805H33-Q1 are fixed-voltage options, while the TPS3803-01-Q1 is adjustable and can be used to monitor any voltage above 1.226 V. The TPS3803G15-Q1 and TPS3803-01-Q1 have an open-drain output, requiring an external pull-up on the RESET line.

9.2 Typical Applications

9.2.1 TPS3803G15-Q1

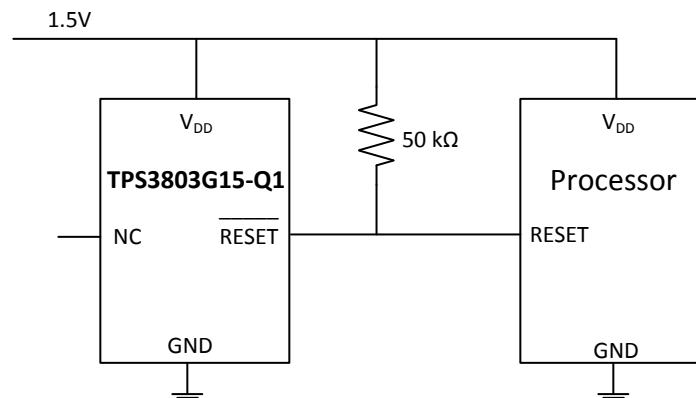

Figure 17. TPS3803G15 Typical Application

9.2.1.1 Design Requirements

When a single 1.5-V supply rail needs to be monitored, TPS3803G15-Q1 should be used. When a single voltage higher than 1.226 V needs to be monitored, TPS3803-01-Q1 should be used. When a 3.3-V supply and second supply above 1.226 V needs to be monitored, TPS3805H33-Q1 should be used.

9.2.1.2 Detailed Design Procedure

To monitor a single 1.5-V supply with TPS3803G15-Q1, connect the 1.5-V supply directly to V_{DD} . The $\overline{\text{RESET}}$ output should be connected to the reset of the microcontroller with a pull-up resistor from the $\overline{\text{RESET}}$ output to V_{DD} .

To monitor a single supply using TPS3803-01-Q1, connect the supply to V_{DD} with a resistor divider to scale down the voltage at the SENSE pin. The resistor values must be chosen to satisfy [Equation 1](#):

$$V_{\text{IT}}' = (1 + R1/R2) \times 1.226$$

where

- V_{IT}' is the V_{DD} threshold voltage. (1)

For example, if TPS3803-01-Q1 should monitor a 2.5-V supply and the desired threshold voltage is 2.2 V, R1 and R2 values could be 24 kΩ and 30- kΩ respectively. A 1-nf to 10-nF decoupling capacitor is recommended to be placed close to the SENSE input.

Typical Applications (continued)

To monitor two supplies using TPS3805H33-Q1, connect the 3.3-V supply directly to V_{DD} , and the second supply through a resistor divider to the SENSE pin. The SENSE pin should have a 1-nF to 10-nF decoupling capacitor close to the pin.

9.2.1.3 Application Curves

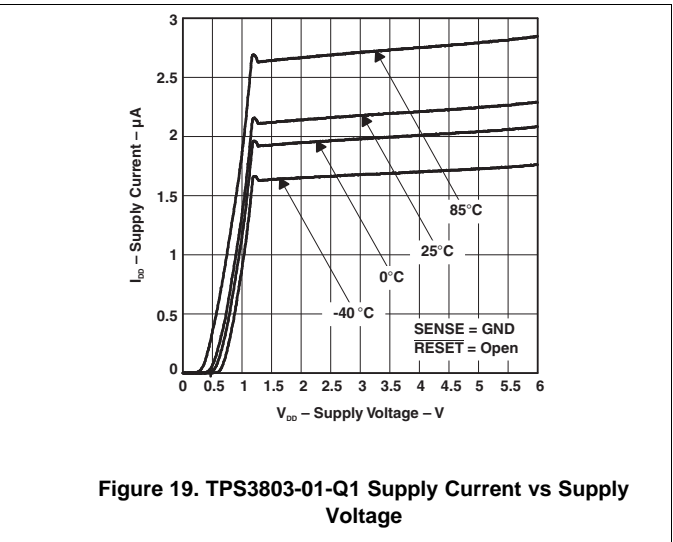
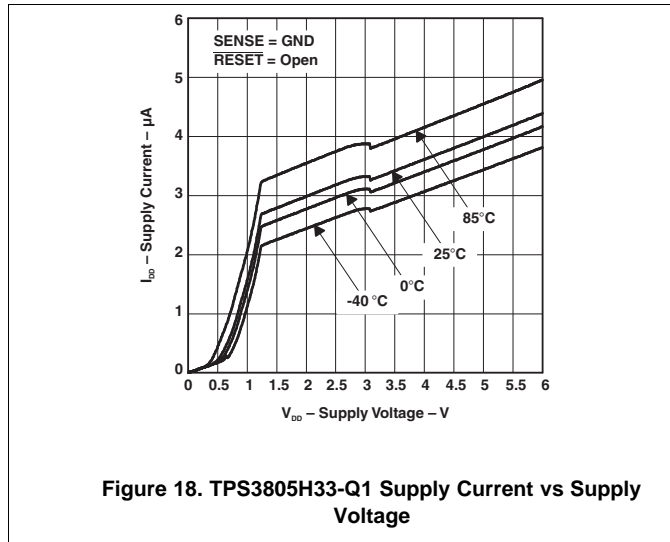

9.2.2 TPS3803-01-Q1

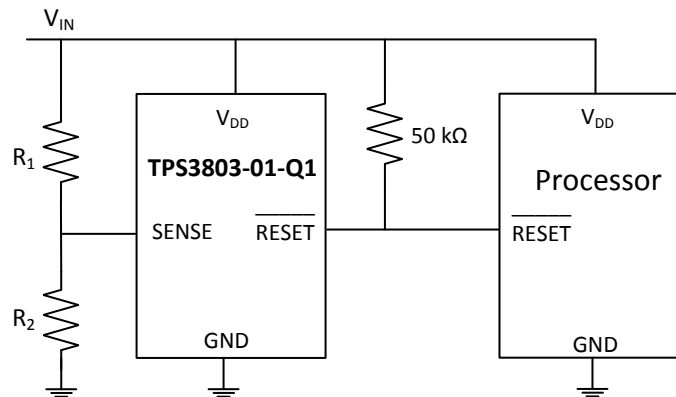

9.2.2.1 Design Requirements

Please refer to [Design Requirements](#) for this device's design requirements.

Typical Applications (continued)

9.2.3 TPS3805H33-Q1

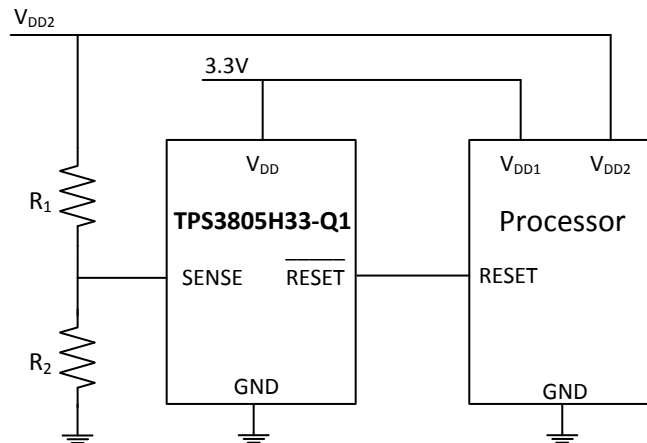

Figure 21. TPS3805H33-Q1 Typical Application

9.2.3.1 Design Requirements

Please refer to [Design Requirements](#) for this device's design requirements.

10 Power Supply Recommendations

The TPS380x-Q1 devices are designed to operate from an input supply from 1.3 V to 6 V. TI recommends to place a 0.1- μ F capacitor near the V_{DD} pin.

11 Layout

11.1 Layout Guidelines

TI recommends to place the 0.1- μF decoupling capacitor close to the V_{DD} pin. The V_{DD} trace should be able to carry 6 μA without a significant drop in voltage. Avoid a long trace from the SENSE pin to the resistor divider.

11.2 Layout Examples

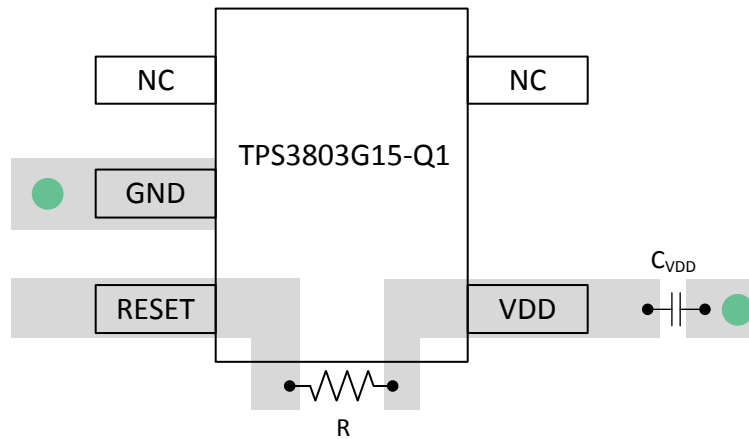

● Denotes GND Via

Figure 22. TPS3803G15-Q1 Layout Example

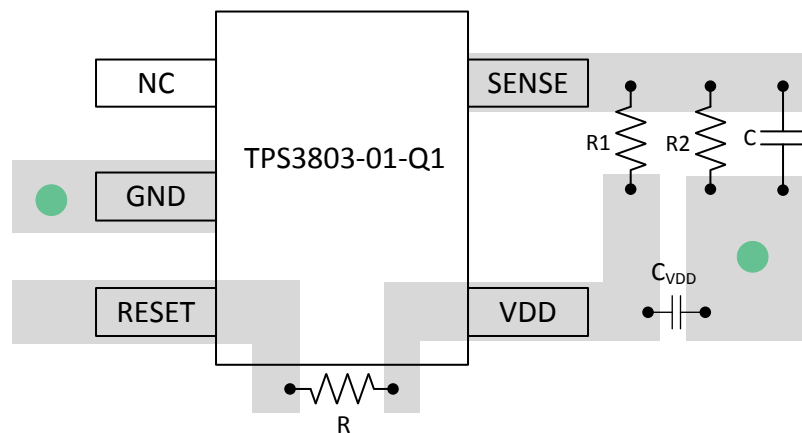

● Denotes GND Via

Figure 23. TPS3803-01-Q1 Layout Example

Layout Examples (continued)

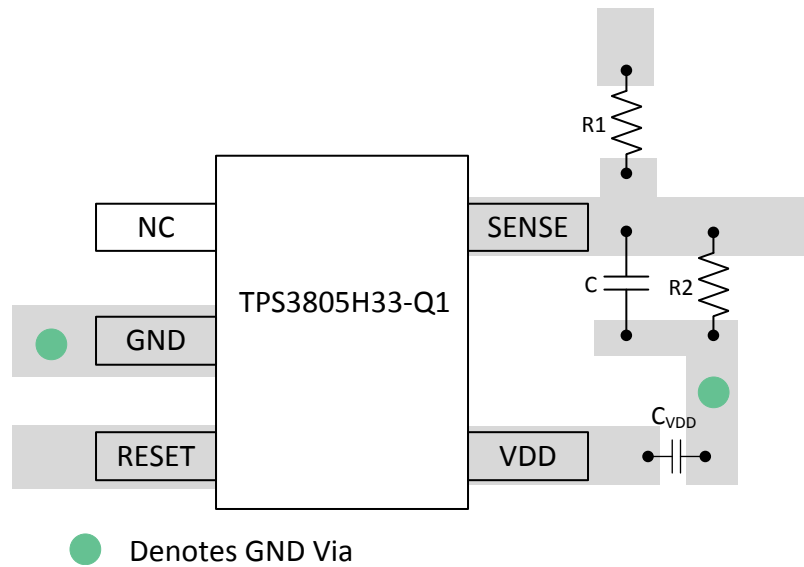
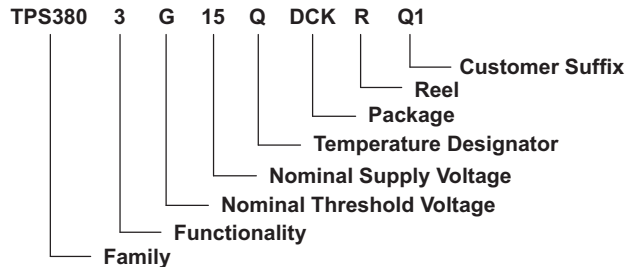

Figure 24. TPS3805H33-Q1 Layout Example

12 Device and Documentation Support

12.1 Device Support

12.1.1 Device Nomenclature



12.2 Related Links

The table below lists quick access links. Categories include technical documents, support and community resources, tools and software, and quick access to sample or buy.

Table 4. Related Links

PARTS	PRODUCT FOLDER	SAMPLE & BUY	TECHNICAL DOCUMENTS	TOOLS & SOFTWARE	SUPPORT & COMMUNITY
TPS3803-01-Q1	Click here	Click here	Click here	Click here	Click here
TPS3803G15-Q1	Click here	Click here	Click here	Click here	Click here
TPS3805H33-Q1	Click here	Click here	Click here	Click here	Click here

12.3 Community Resources

The following links connect to TI community resources. Linked contents are provided "AS IS" by the respective contributors. They do not constitute TI specifications and do not necessarily reflect TI's views; see TI's [Terms of Use](#).

TI E2E™ Online Community *TI's Engineer-to-Engineer (E2E) Community*. Created to foster collaboration among engineers. At e2e.ti.com, you can ask questions, share knowledge, explore ideas and help solve problems with fellow engineers.

Design Support *TI's Design Support* Quickly find helpful E2E forums along with design support tools and contact information for technical support.

12.4 Trademarks

E2E is a trademark of Texas Instruments. All other trademarks are the property of their respective owners.

12.5 Electrostatic Discharge Caution



These devices have limited built-in ESD protection. The leads should be shorted together or the device placed in conductive foam during storage or handling to prevent electrostatic damage to the MOS gates.

12.6 Glossary

SLYZ022 — *TI Glossary*.

This glossary lists and explains terms, acronyms, and definitions.

13 Mechanical, Packaging, and Orderable Information

The following pages include mechanical, packaging, and orderable information. This information is the most current data available for the designated devices. This data is subject to change without notice and revision of this document. For browser-based versions of this data sheet, refer to the left-hand navigation.

PACKAGING INFORMATION

Orderable Device	Status (1)	Package Type	Package Drawing	Pins	Package Qty	Eco Plan (2)	Lead finish/ Ball material (6)	MSL Peak Temp (3)	Op Temp (°C)	Device Marking (4/5)	Samples
2T03-01QDCKRG4Q1	ACTIVE	SC70	DCK	5	3000	RoHS & Green	NIPDAUAG	Level-1-260C-UNLIM	-40 to 125	AWJ	Samples
2T03G15QDCKRG4Q	ACTIVE	SC70	DCK	5	3000	RoHS & Green	NIPDAUAG	Level-1-260C-UNLIM	-40 to 125	AXU	Samples
2T05H33QDCKRG4Q	ACTIVE	SC70	DCK	5	3000	RoHS & Green	NIPDAU NIPDAUAG	Level-1-260C-UNLIM	-40 to 125	AWZ	Samples
TPS3803-01QDCKRQ1	ACTIVE	SC70	DCK	5	3000	RoHS & Green	NIPDAUAG	Level-1-260C-UNLIM	-40 to 125	AWJ	Samples
TPS3803G15QDCKRQ1	ACTIVE	SC70	DCK	5	3000	RoHS & Green	NIPDAU NIPDAUAG	Level-1-260C-UNLIM	-40 to 125	AXU	Samples
TPS3805H33QDCKRQ1	ACTIVE	SC70	DCK	5	3000	RoHS & Green	NIPDAU NIPDAUAG	Level-1-260C-UNLIM	-40 to 125	AWZ	Samples

(1) The marketing status values are defined as follows:

ACTIVE: Product device recommended for new designs.

LIFEBUY: TI has announced that the device will be discontinued, and a lifetime-buy period is in effect.

NRND: Not recommended for new designs. Device is in production to support existing customers, but TI does not recommend using this part in a new design.

PREVIEW: Device has been announced but is not in production. Samples may or may not be available.

OBSOLETE: TI has discontinued the production of the device.

(2) **RoHS:** TI defines "RoHS" to mean semiconductor products that are compliant with the current EU RoHS requirements for all 10 RoHS substances, including the requirement that RoHS substance do not exceed 0.1% by weight in homogeneous materials. Where designed to be soldered at high temperatures, "RoHS" products are suitable for use in specified lead-free processes. TI may reference these types of products as "Pb-Free".

RoHS Exempt: TI defines "RoHS Exempt" to mean products that contain lead but are compliant with EU RoHS pursuant to a specific EU RoHS exemption.

Green: TI defines "Green" to mean the content of Chlorine (Cl) and Bromine (Br) based flame retardants meet JS709B low halogen requirements of <=1000ppm threshold. Antimony trioxide based flame retardants must also meet the <=1000ppm threshold requirement.

(3) MSL, Peak Temp. - The Moisture Sensitivity Level rating according to the JEDEC industry standard classifications, and peak solder temperature.

(4) There may be additional marking, which relates to the logo, the lot trace code information, or the environmental category on the device.

(5) Multiple Device Markings will be inside parentheses. Only one Device Marking contained in parentheses and separated by a "~" will appear on a device. If a line is indented then it is a continuation of the previous line and the two combined represent the entire Device Marking for that device.

(6) Lead finish/Ball material - Orderable Devices may have multiple material finish options. Finish options are separated by a vertical ruled line. Lead finish/Ball material values may wrap to two lines if the finish value exceeds the maximum column width.

Important Information and Disclaimer: The information provided on this page represents TI's knowledge and belief as of the date that it is provided. TI bases its knowledge and belief on information provided by third parties, and makes no representation or warranty as to the accuracy of such information. Efforts are underway to better integrate information from third parties. TI has taken and continues to take reasonable steps to provide representative and accurate information but may not have conducted destructive testing or chemical analysis on incoming materials and chemicals. TI and TI suppliers consider certain information to be proprietary, and thus CAS numbers and other limited information may not be available for release.

In no event shall TI's liability arising out of such information exceed the total purchase price of the TI part(s) at issue in this document sold by TI to Customer on an annual basis.

OTHER QUALIFIED VERSIONS OF TPS3803-Q1, TPS3805H33-Q1 :

- Catalog: [TPS3803](#), [TPS3805H33](#)
- Enhanced Product: [TPS3803-EP](#), [TPS3805H33-EP](#)

NOTE: Qualified Version Definitions:

- Catalog - TI's standard catalog product
- Enhanced Product - Supports Defense, Aerospace and Medical Applications

TAPE AND REEL INFORMATION



QUADRANT ASSIGNMENTS FOR PIN 1 ORIENTATION IN TAPE



*All dimensions are nominal

Device	Package Type	Package Drawing	Pins	SPQ	Reel Diameter (mm)	Reel Width W1 (mm)	A0 (mm)	B0 (mm)	K0 (mm)	P1 (mm)	W (mm)	Pin1 Quadrant
TPS3803G15QDCKRQ1	SC70	DCK	5	3000	180.0	8.4	2.47	2.3	1.25	4.0	8.0	Q3

TAPE AND REEL BOX DIMENSIONS



*All dimensions are nominal

Device	Package Type	Package Drawing	Pins	SPQ	Length (mm)	Width (mm)	Height (mm)
TPS3803G15QDCKRQ1	SC70	DCK	5	3000	183.0	183.0	20.0

DCK (R-PDSO-G5)

PLASTIC SMALL-OUTLINE PACKAGE



- NOTES:
- A. All linear dimensions are in millimeters.
 - B. This drawing is subject to change without notice.
 - C. Body dimensions do not include mold flash or protrusion. Mold flash and protrusion shall not exceed 0.15 per side.
 - D. Falls within JEDEC MO-203 variation AA.

DCK (R-PDSO-G5)

PLASTIC SMALL OUTLINE



- NOTES:
- All linear dimensions are in millimeters.
 - This drawing is subject to change without notice.
 - Customers should place a note on the circuit board fabrication drawing not to alter the center solder mask defined pad.
 - Publication IPC-7351 is recommended for alternate designs.
 - Laser cutting apertures with trapezoidal walls and also rounding corners will offer better paste release. Customers should contact their board assembly site for stencil design recommendations. Example stencil design based on a 50% volumetric metal load solder paste. Refer to IPC-7525 for other stencil recommendations.

IMPORTANT NOTICE AND DISCLAIMER

TI PROVIDES TECHNICAL AND RELIABILITY DATA (INCLUDING DATASHEETS), DESIGN RESOURCES (INCLUDING REFERENCE DESIGNS), APPLICATION OR OTHER DESIGN ADVICE, WEB TOOLS, SAFETY INFORMATION, AND OTHER RESOURCES "AS IS" AND WITH ALL FAULTS, AND DISCLAIMS ALL WARRANTIES, EXPRESS AND IMPLIED, INCLUDING WITHOUT LIMITATION ANY IMPLIED WARRANTIES OF MERCHANTABILITY, FITNESS FOR A PARTICULAR PURPOSE OR NON-INFRINGEMENT OF THIRD PARTY INTELLECTUAL PROPERTY RIGHTS.

These resources are intended for skilled developers designing with TI products. You are solely responsible for (1) selecting the appropriate TI products for your application, (2) designing, validating and testing your application, and (3) ensuring your application meets applicable standards, and any other safety, security, or other requirements. These resources are subject to change without notice. TI grants you permission to use these resources only for development of an application that uses the TI products described in the resource. Other reproduction and display of these resources is prohibited. No license is granted to any other TI intellectual property right or to any third party intellectual property right. TI disclaims responsibility for, and you will fully indemnify TI and its representatives against, any claims, damages, costs, losses, and liabilities arising out of your use of these resources.

TI's products are provided subject to TI's Terms of Sale (www.ti.com/legal/termsofsale.html) or other applicable terms available either on ti.com or provided in conjunction with such TI products. TI's provision of these resources does not expand or otherwise alter TI's applicable warranties or warranty disclaimers for TI products.

Mailing Address: Texas Instruments, Post Office Box 655303, Dallas, Texas 75265
Copyright © 2020, Texas Instruments Incorporated