

## LM51501-Q1 宽输入电压汽车级低 $I_Q$ 升压控制器

### 1 特性

- 符合 AEC-Q100 标准：
  - 器件温度等级 1：-40°C 至 +125°C 环境温度范围
  - 器件 HBM ESD 分类等级 2
  - 器件 CDM ESD 分类等级 C4B
- 提供功能安全
  - 可帮助进行功能安全系统设计的文档
- 输出电压  $\geq 5V$  (绝对最大值为 65V) 时具有 1.5V 至 42V 的宽输入电压范围
- 低关断电流 ( $I_Q \leq 5\mu A$ )
- 低待机电流 ( $I_Q \leq 15\mu A$ )
- 四种可编程输出电压选项和两种可选配置
  - 6.0V、6.5V、9.5V 或 11.5V
  - 启停或紧急呼叫配置
- 可调节开关频率范围：220 kHz 至 2.3 MHz
- 自动唤醒和待机模式转换
- 可选的时钟同步
- 升压状态指示器
- 1.5A 峰值 MOSFET 栅极驱动器
- 可调逐周期电流限制
- 热关断保护
- 16 引脚 WQFN，具有可湿性侧面和非可湿性侧面选项
- 使用 LM51501-Q1 并借助 [WEBENCH® Power Designer](#) 创建定制设计方案

### 2 应用

- 汽车启停系统

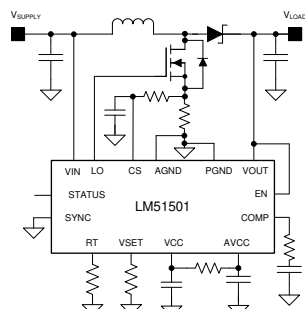

典型应用电路

- 汽车紧急呼叫系统
- 电池供电升压转换器

### 3 说明

LM51501-Q1 是一款具有宽输入电压范围的自动升压控制器。该器件可用于汽车启动期间利用车辆电池或备用电池维持稳定的输出电压。

可以通过一个电阻器在 220kHz 至 2.3MHz 范围内对 LM51501-Q1 开关频率进行编程。快速开关频率 ( $\geq 2.2\text{MHz}$ ) 可更大限度地降低调幅频带干扰，并支持实现小解决方案尺寸和快速瞬态响应。

LM51501-Q1 在输入或输出电压高于预设待机阈值时以低  $I_Q$  待机模式运行，并且在输出电压降至预设唤醒阈值以下时自动唤醒。

该器件可进入或退出低  $I_Q$  待机模式，以在轻负载下延长电池寿命。单个电阻器对目标输出稳定电压以及配置进行编程。其他特性包括低关断电流、升压状态指示器、可调逐周期电流限制和热关断。当器件未进行升压运行时，状态指示器可用于控制电路以绕过二极管，从而降低功率耗散。在紧急呼叫模式下，该器件可用于控制断开开关，保护备用电池。

#### 器件信息

器件型号	封装 <sup>(1)</sup>	封装尺寸 (标称值)
LM51501-Q1	WQFN (16)	4.00mm × 4.00mm

(1) 如需了解所有可用封装，请参阅数据表末尾的可订购产品附录。

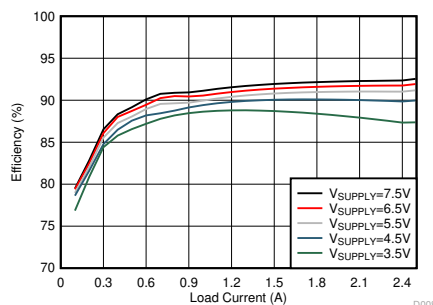

效率 ( $V_{LOAD} = 9.5V$ ,  $F_{SW} = 440\text{kHz}$ )



## Table of Contents

<b>1 特性</b> .....	<b>1</b>	<b>9 Application and Implementation</b> .....	<b>22</b>
<b>2 应用</b> .....	<b>1</b>	9.1 Application Information.....	22
<b>3 说明</b> .....	<b>1</b>	9.2 Typical Application.....	25
<b>4 Revision History</b> .....	<b>2</b>	9.3 System Examples.....	33
<b>5 Device Comparison Table</b> .....	<b>3</b>	<b>10 Power Supply Recommendations</b> .....	<b>35</b>
<b>6 Pin Configuration and Functions</b> .....	<b>4</b>	<b>11 Layout</b> .....	<b>36</b>
<b>7 Specifications</b> .....	<b>5</b>	11.1 Layout Guidelines.....	36
7.1 Absolute Maximum Ratings.....	5	11.2 Layout Example.....	37
7.2 ESD Ratings.....	5	<b>12 Device and Documentation Support</b> .....	<b>38</b>
7.3 Recommended Operating Conditions.....	5	12.1 Device Support.....	38
7.4 Thermal Information.....	6	12.2 接收文档更新通知.....	38
7.5 Electrical Characteristics.....	6	12.3 支持资源.....	38
7.6 Typical Characteristics.....	9	12.4 Trademarks.....	38
<b>8 Detailed Description</b> .....	<b>11</b>	12.5 Electrostatic Discharge Caution.....	38
8.1 Overview.....	11	12.6 术语表.....	38
8.2 Functional Block Diagram.....	11	<b>13 Mechanical, Packaging, and Orderable Information</b> .....	<b>39</b>
8.3 Feature Description.....	12		
8.4 Device Functional Modes.....	18		

## 4 Revision History

注：以前版本的页码可能与当前版本的页码不同

<b>Changes from Revision B (June 2020) to Revision C (October 2021)</b>	<b>Page</b>
• 更新了整个文档中的表格、图和交叉参考的编号格式.....	1
• 添加了非可湿性侧面选项.....	1
• Added <a href="#">节 5</a> .....	3

---

<b>Changes from Revision A (May 2018) to Revision B (June 2020)</b>	<b>Page</b>
• 向 <a href="#">节 1</a> 添加了功能安全要点.....	1

## 5 Device Comparison Table

PART NUMBER	PACKAGE OUTLINE	WETTABLE (WF)/NON-WETTABLE FLANKS (NON-WF)
LM51501QRUMRQ1	RUM0016C	WF
LM51501QRUMTQ1		
LM51501QURUMRQ1	RUM0016F	Non-WF

## 6 Pin Configuration and Functions



图 6-1. 16-Pin WQFN RUM Package (Top View)

表 6-1. Pin Functions

PIN		I/O <sup>(1)</sup>	DESCRIPTION
NO.	NAME		
1	SYNC	I	External synchronization clock input pin. The internal oscillator is synchronized to an external clock by applying a pulse signal into the SYNC pin in the start-stop configuration. Connect directly to ground if not used or in an emergency call configuration. Maximum duty cycle limit can be programmed by controlling the external synchronization clock frequency.
2	STATUS	O	Status indicator with an open-drain output stage. An internal pulldown switch holds the pin low when the device is not boosting. The pin can be left floating if not used.
3	EN	I	Enable pin. If EN is below 1 V, the device is in shutdown mode. The pin must be raised above 2 V to enable the device. Connect directly to the VOUT pin for an automatic boost.
4	VOUT	I/P	Boost output voltage-sensing pin and input to the VCC regulator. Connect to the output of the boost converter.
5	PVCC	O/P	Output of the VCC bias regulator. Decouple locally to PGND using a low-ESR or low-ESL ceramic capacitor placed as close to the device as possible.
6	NC	—	No internal electrical connection. Leave the pin floating or connect directly to ground.
7	AVCC	I/P	Analog VCC supply input. Decouple locally to AGND using a 0.1- $\mu$ F, low-ESR or low-ESL ceramic capacitor placed as close to the device as possible. Connect to the PVCC pin through 10- $\Omega$ resistor.
8	NC	—	No internal electrical connection. Leave the pin floating or connect directly to ground.
9	LO	O	N-channel MOSFET gate drive output. Connect to the gate of the N-channel MOSFET through a short, low inductance path.
10	PGND	G	Power ground pin. Connect to the ground connection of the sense resistor through a wide and short path.
11	AGND	G	Analog ground pin. Connect to the analog ground plane through a wide and short path.
12	CS	I	Current sense input pin. Connect to the positive side of the current sense resistor through a short path.
13	COMP	O	Output of the internal transconductance error amplifier. The loop compensation components must be connected between this pin and AGND.
14	RT	I	Switching frequency setting pin. The switching frequency is programmed by a single resistor between RT and AGND.
15	VSET	I	Configuration selection and VOUT regulation target programming pin. During initial power on, a resistor between the VSET pin and AGND configures the VOUT regulation target and the configuration.
16	VIN	I	Boost input voltage sensing pin. Connect to the input supply of the boost converter.
—	EP	—	Exposed pad of the package. No internal electrical connection to silicon die. The EP is electrically connected to anchor pads. The EP must be connected to the large ground copper plain to reduce thermal resistance.
—	AP	—	Anchor pad of the package. No internal electrical connection to silicon die. The AP is electrically connected to the EP. The AP can be left floating or soldered to the ground copper.

(1) G = Ground, I = Input, O = Output, P = Power

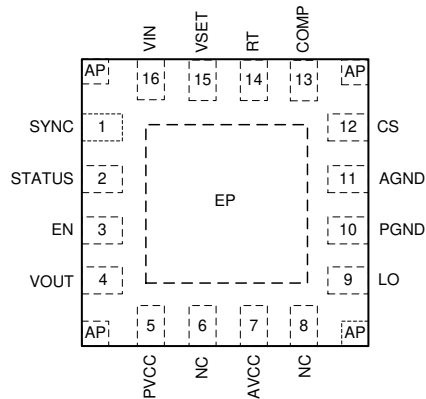
## 7 Specifications

### 7.1 Absolute Maximum Ratings

Over the recommended operating junction temperature range of  $-40^{\circ}\text{C}$  to  $150^{\circ}\text{C}$  (unless otherwise specified)<sup>(1)</sup>

		MIN	MAX	UNIT
Input	VIN to AGND	-0.3	65	V
	VOUT to AGND	-0.3	65	
	EN to AGND	-0.3	65	
	RT to AGND <sup>(2)</sup>	-0.3	AVCC + 0.3	
	SYNC to AGND	-0.3	7	
	VSET to AGND	-0.3	7	
	CS to AGND (DC)	-0.3	AVCC + 0.3	
	CS to AGND (40-ns transient)	-1.0	AVCC + 0.3	
	CS to AGND (20-ns transient)	-2.0	AVCC + 0.3	
	PGND to AGND	-0.3	0.3	
Output	LO to AGND (DC)	-0.3	PVCC + 0.3	V
	LO to AGND (40-ns transient)	-1.0	PVCC + 0.3	
	LO to AGND (20-ns transient)	-2.0	PVCC + 0.3	
	STATUS to AGND <sup>(3)</sup>	-0.3	65	
	COMP to AGND <sup>(2)</sup>	-0.3	AVCC + 0.3	
	AVCC to AGND	-0.3	7	
	PVCC to AVCC	-0.3	0.3	
T <sub>J</sub>	Junction temperature <sup>(4)</sup>	-40	150	°C
T <sub>STG</sub>	Storage temperature	-55	150	

- (1) Stresses beyond those listed under *Absolute Maximum Ratings* may cause permanent damage to the device. These are stress ratings only, which do not imply functional operation of the device at these or any other conditions beyond those indicated under *Recommended Operating Conditions*. Exposure to absolute-maximum-rated conditions for extended periods may affect device reliability.
- (2) The pin voltage is clamped by an internal circuit, and is not specified to have an external voltage applied.
- (3) STATUS can go below ground during the STATUS low-to-high transition. The negative voltage on STATUS during this transition is clamped by an internal diode and it does not damage the device.
- (4) High junction temperatures degrade operating lifetimes. Operating lifetime is de-rated for junction temperatures greater than  $125^{\circ}\text{C}$ .

### 7.2 ESD Ratings

			MIN	MAX	UNIT	
V <sub>(ESD)</sub>	Electrostatic discharge	Human body model (HBM), per AEC Q100-002 <sup>(1)</sup>	-2000	2000	V	
		Charged device model (CDM), per AEC Q100-011	Corner pins	-750		750
			Other pins	-500		500

- (1) AEC Q100-002 indicates that HBM stressing shall be in accordance with the ANSI/ESDA/JEDEC JS-001 specification.

### 7.3 Recommended Operating Conditions

Over the recommended operating junction temperature range of  $-40^{\circ}\text{C}$  to  $150^{\circ}\text{C}$  (unless otherwise specified)<sup>(1)</sup>

		MIN	NOM	MAX	UNIT
V <sub>VIN</sub>	Boost input voltage sense	1.5		42	V
V <sub>VOUT</sub>	Boost output voltage sense <sup>(2)</sup>	5		42	V
V <sub>EN</sub>	EN input	0		42	V
V <sub>VCC</sub>	PVCC voltage <sup>(3)</sup>	4.5	5	5.5	V
V <sub>SYNC</sub>	SYNC input	0		5.5	V

**LM51501-Q1**

ZHCSHU0C - MARCH 2018 - REVISED OCTOBER 2021

 Over the recommended operating junction temperature range of  $-40^{\circ}\text{C}$  to  $150^{\circ}\text{C}$  (unless otherwise specified)<sup>(1)</sup>

		MIN	NOM	MAX	UNIT
V <sub>CS</sub>	Current sense input	0		0.3	V
F <sub>SW</sub>	Typical switching frequency	220		2300	kHz
F <sub>SYNC</sub>	Synchronization pulse frequency	220		2300	kHz
T <sub>J</sub>	Operating junction temperature <sup>(4)</sup>	-40		150	°C

- (1) Operating Ratings are conditions under the device is intended to be functional. For specifications and test conditions, see the [Electrical Characteristics](#).
- (2) The device requires a minimum 5 V at the VOUT pin to start up.
- (3) V<sub>PVCC</sub> should be less than V<sub>VOUT</sub> + 0.3.
- (4) High junction temperatures degrade operating lifetimes. Operating lifetime is de-rated for junction temperatures greater than 125°C.

## 7.4 Thermal Information

THERMAL METRIC <sup>(1)</sup>		LM51501-Q1	UNIT
		RUM (WQFN) 16 PINS	
R <sub>θJA</sub>	Junction-to-ambient thermal resistance	44.4	°C/W
R <sub>θJC(top)</sub>	Junction-to-case (top) thermal resistance	33.4	°C/W
R <sub>θJB</sub>	Junction-to-board thermal resistance	19.5	°C/W
ψ <sub>JT</sub>	Junction-to-top characterization parameter	0.5	°C/W
ψ <sub>JB</sub>	Junction-to-board characterization parameter	19.3	°C/W
R <sub>θJC(bot)</sub>	Junction-to-case (bottom) thermal resistance	2.0	°C/W

- (1) For more information about traditional and new thermal metrics, see the [Semiconductor and IC Package Thermal Metrics](#) application report (SPRA953).

## 7.5 Electrical Characteristics

 Typical values correspond to T<sub>J</sub> = 25°C. Minimum and maximum limits apply over T<sub>J</sub> =  $-40^{\circ}\text{C}$  to  $125^{\circ}\text{C}$ . Unless otherwise stated, V<sub>VOUT</sub> = 9.5 V, R<sub>T</sub> = 9.09 kΩ

PARAMETER		TEST CONDITIONS	MIN	TYP	MAX	UNIT
<b>SUPPLY CURRENT</b>						
I <sub>SHUTDOWN(VOUT)</sub>	VOUT shutdown current	V <sub>VOUT</sub> = 12 V, V <sub>EN</sub> = 0 V		5	12	μA
I <sub>STANDBY(VOUT)</sub>	VOUT standby current (PVCC in regulation, STATUS is low)	V <sub>VOUT</sub> = 12 V, V <sub>EN</sub> = 3.3 V, R <sub>SET</sub> = 90.9 kΩ		15	25	μA
I <sub>WAKEUP(VOUT)</sub>	VOUT operating current (exclude the current into the RT resistor)	V <sub>VOUT</sub> = 11.5 V, V <sub>EN</sub> = 2.5 V, nonswitching, R <sub>T</sub> = 9.09 kΩ		1.2	2.0	mA
I <sub>SHUTDOWN(VIN)</sub>	VIN shutdown current	V <sub>VIN</sub> = 12 V, V <sub>EN</sub> = 0 V		0.1	0.5	μA
I <sub>STANDBY(VIN)</sub>	VIN standby current	V <sub>VIN</sub> = 12 V, V <sub>EN</sub> = 3.3 V, R <sub>SET</sub> = 29.4 kΩ		0.1	0.5	μA
I <sub>WAKEUP(VIN)</sub>	VIN operating current	V <sub>VIN</sub> = 11.5 V, V <sub>EN</sub> = 2.5 V, nonswitching, R <sub>T</sub> = 9.09 kΩ		30	45	μA
<b>VCC REGULATOR</b>						
V <sub>VCC-REG-NOLOAD</sub>	PVCC regulation	V <sub>VOUT</sub> = 6.0 V, no load, wake-up mode	4.75	5	5.25	V
V <sub>VCC-REG-FULLLOAD</sub>	PVCC regulation	V <sub>VOUT</sub> = 5.0 V, I <sub>PVCC</sub> = 70 mA	4.5	4.8		V
V <sub>VCC-UVLO-RISING</sub>	AVCC UVLO threshold	AVCC rising	4.1	4.3	4.5	V
V <sub>VCC-UVLO-FALLING</sub>	AVCC UVLO threshold	AVCC falling	3.9	4.1	4.3	V
V <sub>VCC-UVLO-HYS</sub>	AVCC UVLO hysteresis			0.2		V
I <sub>VCC-CL</sub>	PVCC sourcing current limit	V <sub>PVCC</sub> = 0 V, wake-up mode	75			mA
<b>ENABLE</b>						
V <sub>EN-RISING</sub>	Enable threshold	EN rising		1.7	2	V
V <sub>EN-FALLING</sub>	Enable threshold	EN falling	1	1.3		V
I <sub>EN</sub>	EN bias current	V <sub>EN</sub> = 42 V			100	nA

Typical values correspond to  $T_J = 25^\circ\text{C}$ . Minimum and maximum limits apply over  $T_J = -40^\circ\text{C}$  to  $125^\circ\text{C}$ . Unless otherwise stated,  $V_{\text{VOUT}} = 9.5\text{ V}$ ,  $R_T = 9.09\text{ k}\Omega$

PARAMETER		TEST CONDITIONS	MIN	TYP	MAX	UNIT
<b>6.0V SETTING</b>						
$V_{\text{VOUT-REG}}$	VOUT regulation target	$R_{\text{SET}} = 29.4\text{ k}\Omega$ or $90.9\text{ k}\Omega$	5.88	6.00	6.12	V
$V_{\text{VOUT-WAKEUP}}$	VOUT wake-up threshold ( $V_{\text{VOUT-REG}} + 3\%$ )	$R_{\text{SET}} = 29.4\text{ k}\Omega$ or $90.9\text{ k}\Omega$ , VOUT falling	6.06	6.18	6.30	V
$V_{\text{VOUT-STANDBY1}}$	VOUT standby threshold ( $V_{\text{VOUT-REG}} + 6\%$ , EC config)	$R_{\text{SET}} = 90.9\text{ k}\Omega$ , VOUT rising	6.23	6.36	6.49	V
$V_{\text{VOUT-STATUS-OFF}}$	VOUT status off threshold ( $V_{\text{VOUT-REG}} + 12\%$ , EC config)	$R_{\text{SET}} = 90.9\text{ k}\Omega$ , VOUT rising	6.59	6.72	6.85	V
$V_{\text{VOUT-STANDBY2}}$	VOUT standby threshold ( $V_{\text{VOUT-REG}} + 24\%$ , SS config)	$R_{\text{SET}} = 29.4\text{ k}\Omega$ , VOUT rising	7.30	7.44	7.54	V
$V_{\text{VIN-STANDBY}}$	VIN standby threshold ( $V_{\text{VOUT-WAKEUP}} + 1.0\text{ V}$ , SS config)	$R_{\text{SET}} = 29.4\text{ k}\Omega$ , VIN rising	7.04	7.18	7.32	V
<b>6.5V SETTING</b>						
$V_{\text{VOUT-REG}}$	VOUT regulation target	$R_{\text{SET}} = 19.1\text{ k}\Omega$ or $71.5\text{ k}\Omega$	6.37	6.50	6.63	V
$V_{\text{VOUT-WAKEUP}}$	VOUT wake-up threshold ( $V_{\text{VOUT-REG}} + 3\%$ )	$R_{\text{SET}} = 19.1\text{ k}\Omega$ or $71.5\text{ k}\Omega$ , VOUT falling	6.56	6.70	6.83	V
$V_{\text{VOUT-STANDBY1}}$	VOUT standby threshold ( $V_{\text{VOUT-REG}} + 6\%$ , EC config)	$R_{\text{SET}} = 71.5\text{ k}\Omega$ , VOUT rising	6.75	6.89	7.03	V
$V_{\text{VOUT-STATUS-OFF}}$	VOUT status off threshold ( $V_{\text{VOUT-REG}} + 12\%$ , EC config)	$R_{\text{SET}} = 71.5\text{ k}\Omega$ , VOUT rising	7.13	7.28	7.43	V
$V_{\text{VOUT-STANDBY2}}$	VOUT standby threshold ( $V_{\text{VOUT-REG}} + 24\%$ , SS config)	$R_{\text{SET}} = 19.1\text{ k}\Omega$ , VOUT rising	7.92	8.06	8.16	V
$V_{\text{VIN-STANDBY}}$	VIN standby threshold ( $V_{\text{VOUT-WAKEUP}} + 1.0\text{ V}$ , SS config)	$R_{\text{SET}} = 19.1\text{ k}\Omega$ , VIN rising	7.54	7.70	7.85	V
<b>9.5V SETTING</b>						
$V_{\text{VOUT-REG}}$	VOUT regulation target	$R_{\text{SET}} = 9.53\text{ k}\Omega$ or $54.9\text{ k}\Omega$	9.31	9.50	9.69	V
$V_{\text{VOUT-WAKEUP}}$	VOUT wake-up threshold ( $V_{\text{VOUT-REG}} + 3\%$ )	$R_{\text{SET}} = 9.53\text{ k}\Omega$ or $54.9\text{ k}\Omega$ , VOUT falling	9.59	9.79	9.98	V
$V_{\text{VOUT-STANDBY1}}$	VOUT standby threshold ( $V_{\text{VOUT-REG}} + 6\%$ , EC config)	$R_{\text{SET}} = 54.9\text{ k}\Omega$ , VOUT rising	9.87	10.07	10.27	V
$V_{\text{VOUT-STATUS-OFF}}$	VOUT status off threshold ( $V_{\text{VOUT-REG}} + 12\%$ , EC config)	$R_{\text{SET}} = 54.9\text{ k}\Omega$ , VOUT rising	10.43	10.64	10.85	V
$V_{\text{VOUT-STANDBY2}}$	VOUT standby threshold ( $V_{\text{VOUT-REG}} + 24\%$ , SS config)	$R_{\text{SET}} = 9.53\text{ k}\Omega$ , VOUT rising	11.55	11.78	11.95	V
$V_{\text{VIN-STANDBY}}$	VIN standby threshold ( $V_{\text{VOUT-WAKEUP}} + 1.0\text{ V}$ , SS mode)	$R_{\text{SET}} = 9.53\text{ k}\Omega$ , VIN rising	10.57	10.79	11.00	V
<b>11.5V SETTING</b>						
$V_{\text{VOUT-REG}}$	VOUT regulation target	$R_{\text{SET}} = \text{GND}$ or $41.2\text{ k}\Omega$	11.27	11.50	11.73	V
$V_{\text{VOUT-WAKEUP}}$	VOUT wake-up threshold ( $V_{\text{VOUT-REG}} + 3\%$ )	$R_{\text{SET}} = \text{GND}$ or $41.2\text{ k}\Omega$ , VOUT falling	11.61	11.85	12.08	V
$V_{\text{VOUT-STANDBY1}}$	VOUT standby threshold ( $V_{\text{VOUT-REG}} + 6\%$ , EC config)	$R_{\text{SET}} = 41.2\text{ k}\Omega$ , VOUT rising	11.95	12.19	12.43	V
$V_{\text{VOUT-STATUS-OFF}}$	VOUT status off threshold ( $V_{\text{VOUT-REG}} + 12\%$ , EC config)	$R_{\text{SET}} = 41.2\text{ k}\Omega$ , VOUT rising	12.62	12.88	13.14	V
$V_{\text{VOUT-STANDBY2}}$	VOUT standby threshold ( $V_{\text{VOUT-REG}} + 24\%$ , SS config)	$R_{\text{SET}} = \text{GND}$ , VOUT rising	13.98	14.26	14.55	V
$V_{\text{VIN-STANDBY}}$	VIN standby threshold ( $V_{\text{VOUT-WAKEUP}} + 1.0\text{ V}$ , SS config)	$R_{\text{SET}} = \text{GND}$ , VIN rising	12.52	12.85	13.10	V
<b>RT</b>						
$V_{\text{RT-REG}}$	RT regulation voltage			1.2		V

**LM51501-Q1**

ZHC SHU0C - MARCH 2018 - REVISED OCTOBER 2021

Typical values correspond to  $T_J = 25^\circ\text{C}$ . Minimum and maximum limits apply over  $T_J = -40^\circ\text{C}$  to  $125^\circ\text{C}$ . Unless otherwise stated,  $V_{\text{VOUT}} = 9.5\text{ V}$ ,  $R_T = 9.09\text{ k}\Omega$

PARAMETER		TEST CONDITIONS	MIN	TYP	MAX	UNIT
<b>CLOCK SYNCHRONIZATION</b>						
$V_{\text{SYNC-RISING}}$	SYNC rising threshold			2.0	2.4	V
$V_{\text{SYNC-FALLING}}$	SYNC falling threshold		0.4	1.5		V
<b>PULSE WIDTH MODULATION AND OSCILLATOR</b>						
$F_{\text{SW1}}$	Switching frequency	$R_T = 93.1\text{ k}\Omega$	204	239	270	kHz
$F_{\text{SW2}}$	Switching frequency	$R_T = 9.09\text{ k}\Omega$	2100	2300	2500	kHz
$F_{\text{SW3}}$	Switching frequency	$R_T = 9.09\text{ k}\Omega$ , $F_{\text{SYNC}} = 2.0\text{ MHz}$		2000		kHz
$T_{\text{ON-MIN}}$	Forced minimum on time	SS config, $V_{\text{COMP}} = 0\text{ V}$	30	50	70	ns
$D_{\text{MIN}}$	Minimum duty cycle limit (EC config)	$R_T = 9.09\text{ k}\Omega$ , $V_{\text{VIN}} = 1.5\text{ V}$ , $V_{\text{VOUT}} = 6.5\text{ V}$ , $V_{\text{COMP}} = 0\text{ V}$		59		%
		$R_T = 93.1\text{ k}\Omega$ , $V_{\text{VIN}} = 7.6\text{ V}$ , $V_{\text{VOUT}} = 9.5\text{ V}$ , $V_{\text{COMP}} = 0\text{ V}$		16		%
$D_{\text{MAX}}$	Maximum duty cycle limit	SS config, $R_T = 9.09\text{ k}\Omega$	83	87	91	%
		EC config, $R_T = 93.1\text{ k}\Omega$	83	87	93	%
<b>CURRENT SENSE</b>						
$V_{\text{CLTH}}$	Current Limit threshold (CS-AGND) <sup>(1)</sup>	$V_{\text{VIN}} = 7.13\text{ V}$ , $V_{\text{VOUT}} = 9.5\text{ V}$ at 25% DC	102	120	138	mV
		$V_{\text{VIN}} = 4.75\text{ V}$ , $V_{\text{VOUT}} = 9.5\text{ V}$ at 50% DC	102	120	138	mV
		$V_{\text{VIN}} = 2.38\text{ V}$ , $V_{\text{VOUT}} = 9.5\text{ V}$ at 75% DC	102	120	138	mV
<b>ERROR AMPLIFIER</b>						
$G_m$	Transconductance			2		mA/V
	COMP sourcing current	$V_{\text{COMP}} = 0\text{ V}$	312			$\mu\text{A}$
	COMP sinking current	$V_{\text{COMP}} = 1.5\text{ V}$	120			$\mu\text{A}$
	COMP clamp voltage		2.4	2.6		V
	COMP to PWM offset			0.3		V
<b>STATUS</b>						
	Low-state voltage drop	1-mA sinking		0.1		V
	STATUS rise to LO delay	5-k $\Omega$ pullup to 5 V	4	5	6	$\mu\text{s}$
<b>MOSFET DRIVER</b>						
	High-state voltage drop	50-mA sinking		0.075		V
	Low-state voltage drop	50mA sourcing		0.055		V
<b>THERMAL SHUTDOWN (TSD)</b>						
	Thermal shutdown threshold	Temperature rising		175		$^\circ\text{C}$
	Thermal shutdown hysteresis			15		$^\circ\text{C}$

(1)  $V_{\text{CL}}$  at the current limit comparator input is  $10 \times V_{\text{CLTH}}$

## 7.6 Typical Characteristics



图 7-1. Peak Inductor Current vs Supply Voltage  
( $F_{SW} = 440 \text{ kHz}$ ,  $R_S = 7 \text{ m}\Omega$ ,  $R_F = 100 \text{ }\Omega$ ,  $C_F = 2.2 \text{ nF}$ )



图 7-2. Current Limit Threshold at CS vs Duty Cycle

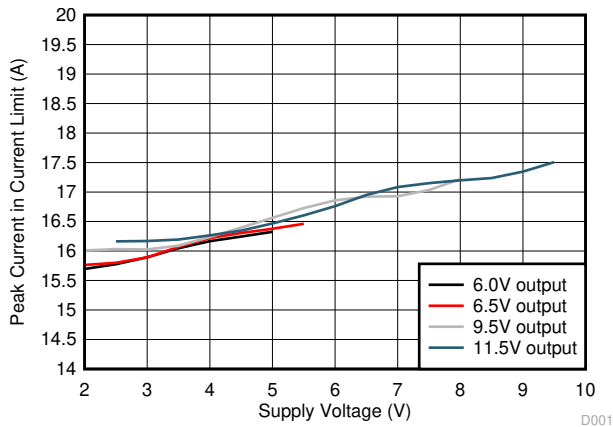

图 7-3.  $V_{PVCC}$  vs  $I_{PVCC}$  ( $V_{OUT} = 6 \text{ V}$ )

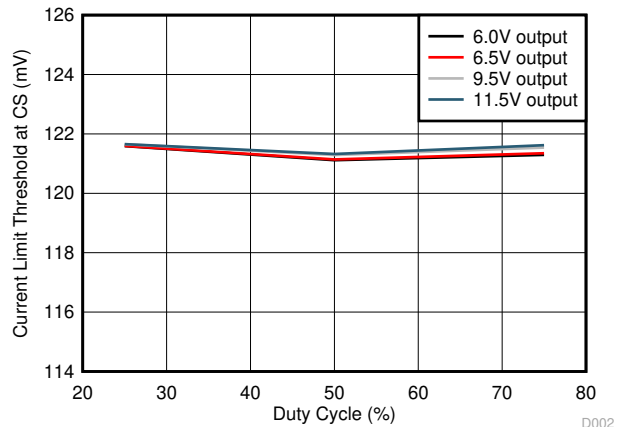

图 7-4.  $V_{PVCC}$  vs  $V_{VOUT}$  ( $EN = 3.3 \text{ V}$ ,  $I_{PVCC} = 10 \text{ mA}$ ,  $V_{OUT}$  Rising)

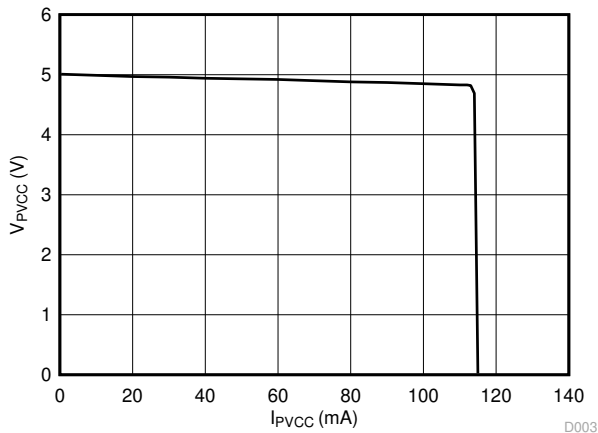

图 7-5. Frequency vs  $R_T$

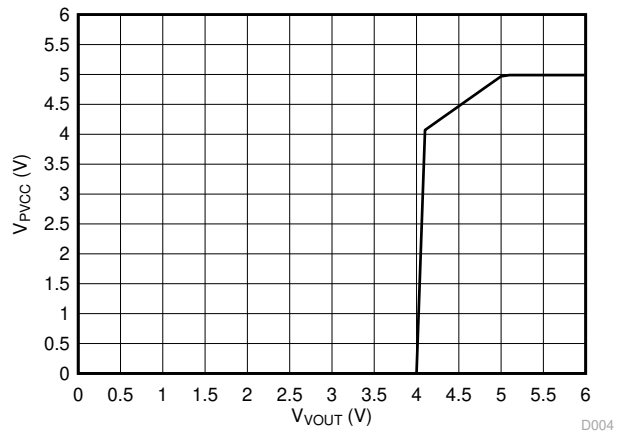

图 7-6. Duty Cycle Limit in EC Configuration vs  $V_{VIN}$

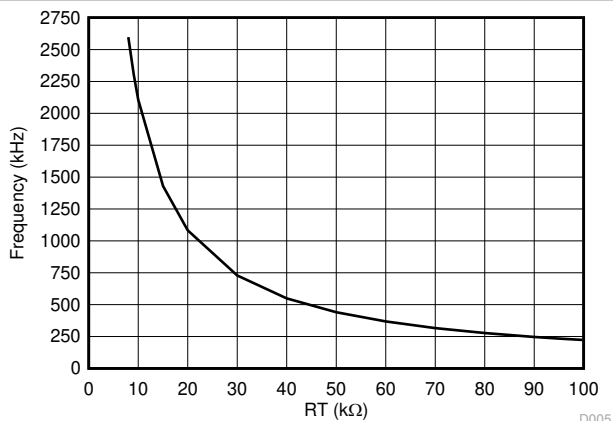

图 7-7. I<sub>VOUT</sub> vs Temperature

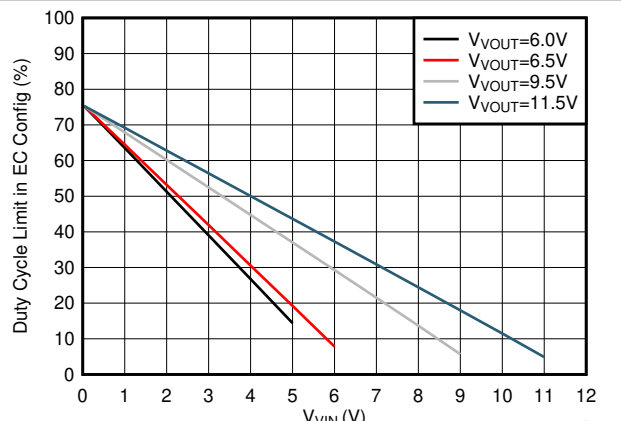

图 7-8. Efficiency vs Load Current (V<sub>LOAD</sub> = 9.5 V, F<sub>SW</sub> = 440 kHz, SS Configuration)

## 8 Detailed Description

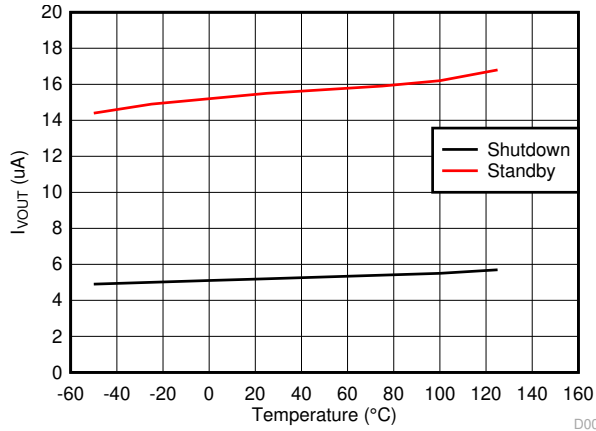
### 8.1 Overview

The LM51501-Q1 device is a wide input range automotive boost controller designed for automotive start-stop or emergency-call applications. The device can maintain the output voltage from a vehicle battery during automotive cranking or from a backup battery during the loss of vehicle battery. The wide input range of the device covers automotive load dump transient. The control method is based upon peak current mode control.

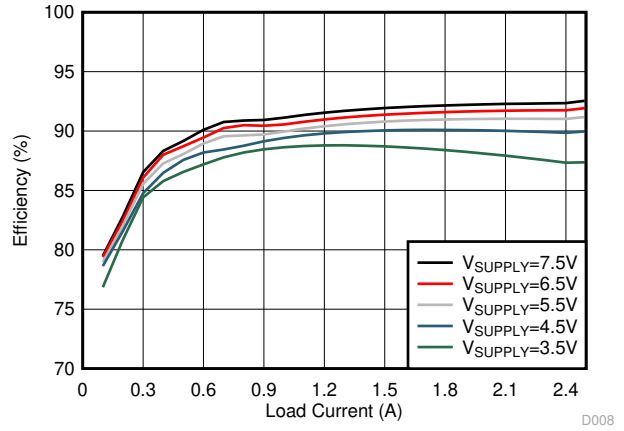
To extend the battery life time, the LM51501-Q1 features a low  $I_Q$  standby mode with automatic wake-up and standby control. The device stays in low  $I_Q$  standby mode when the boost operation is not required, and automatically enters the wake-up mode when the output voltage drops below the preset wake-up threshold. High value feedback resistors are included inside the device to minimize leakage current in low  $I_Q$  standby mode.

The LM51501-Q1 operates in one of two selectable configurations when waking up. In Start-Stop configuration (SS configuration), the device runs at a fixed switching frequency without any pulse skipping until entering into the standby mode, which helps to have a fixed EMI spectrum. In Emergency-Call configuration (EC configuration), the device will skip pulses as it automatically alternates between low  $I_Q$  standby mode and wake-up mode to extend the battery life in light load conditions.

The LM51501-Q1 switching frequency is programmable from 220 kHz to 2.3 MHz. Fast switching ( $\geq 2.2$  MHz) minimizes AM band interference and allows for a small solution size and fast transient response. A single resistor at the VSET pin programs the target output regulation voltage as well as the configuration. This eliminates the need for an external feedback resistor divider which enables low  $I_Q$  operation. The device also features clock synchronization in the SS configuration, low quiescent current in shutdown mode, a boost status indicator, adjustable cycle-by-cycle current will limit, and thermal shutdown protection.

### 8.2 Functional Block Diagram

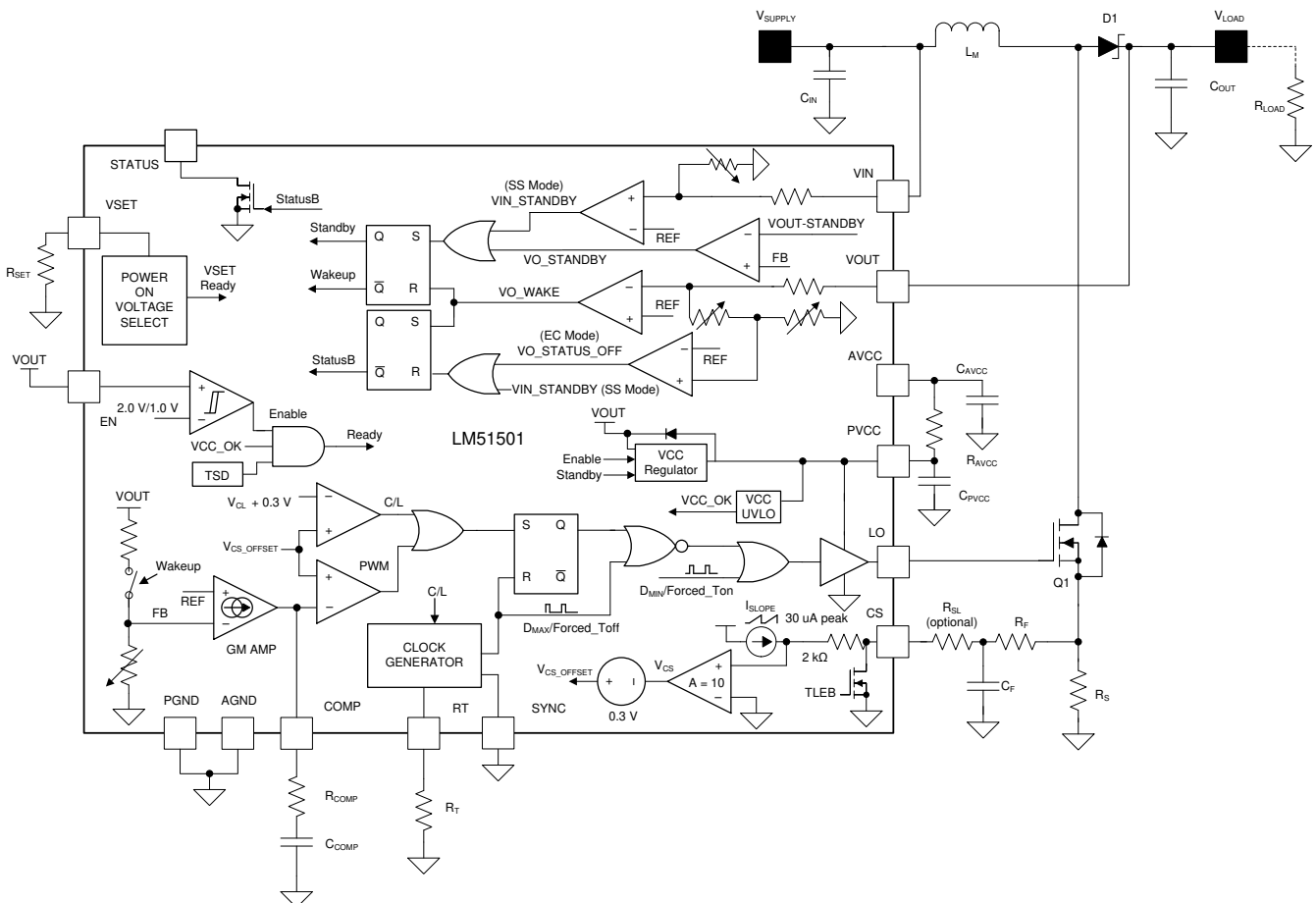

## 8.3 Feature Description

### 8.3.1 Enable (EN Pin)

When the EN pin voltage is less than 1 V, the LM51501-Q1 is in shutdown mode with all other functions disabled. To turn on the internal VCC regulator and begin the start-up sequence, the EN pin voltage must be greater than 2 V. If the EN pin is controlled by user input, TI recommends supplying a voltage greater than 3 V at the EN pin. If the EN pin is not controlled by user input, connect the EN pin to the VOUT pin directly. See [§ 8.4](#) for more detailed information.

### 8.3.2 High Voltage VCC Regulator (PVCC, AVCC Pin)

The LM51501-Q1 contains an internal high voltage VCC regulator. The VCC regulator turns on when the EN pin voltage is greater than 2 V. The VCC regulator is sourced from the VOUT pin and provides 5 V (typical) bias supply for the N-channel MOSFET driver and other internal circuits.

The VCC regulator sources current into the capacitor connected to the PVCC pin with a minimum of 75-mA capability when the LM51501-Q1 is in wake-up mode during the device configuration period. The maximum sourcing capability is decreased to 17 mA in standby mode. The recommended PVCC capacitor is 4.7  $\mu\text{F}$  to 10  $\mu\text{F}$ . In normal operation, the PVCC pin voltage is either 5 V or  $V_{\text{VOUT}} + 0.3$  V, whichever is lower.

The AVCC pin is the analog bias supply input of the LM51501-Q1. The recommended AVCC capacitor is 0.1  $\mu\text{F}$ . Connect to the PVCC pin through a 10- $\Omega$  resistor.

### 8.3.3 Power-On Voltage Selection (VSET Pin)

During initial power on, the VOUT regulation target and the configuration are configured by a resistor connected between the VSET and the AGND pins. The configuration starts when the EN pin voltage is greater than 2 V and the AVCC voltage crosses the AVCC UVLO threshold, which typically requires 50  $\mu\text{s}$  to finish. To reset and reconfigure, the EN should be toggled below 1 V or the AVCC/VOUT must be fully discharged.



图 8-1. Power-On Voltage Selection

The VOUT regulation target can be programmed to 6.0 V, 6.5 V, 9.5 V, or 11.5 V with the appropriate resistor with 5% tolerance. The configuration can be selected as either SS or EC configuration. The LM51501-Q1 will not switch during the 50- $\mu\text{s}$  configuration time.

表 8-1. VSET Resistors<sup>(1)</sup>

CONFIGURATION	EMERGENCY-CALL				START-STOP			
	6.0 V	6.5 V	9.5 V	11.5 V	6.0 V	6.5 V	9.5 V	11.5 V
VOUT regulation target	6.0 V	6.5 V	9.5 V	11.5 V	6.0 V	6.5 V	9.5 V	11.5 V
R <sub>SET</sub> [ $\Omega$ ]	90.9k	71.5k	54.9k	41.2k	29.4k	19.1k	9.53k	Ground

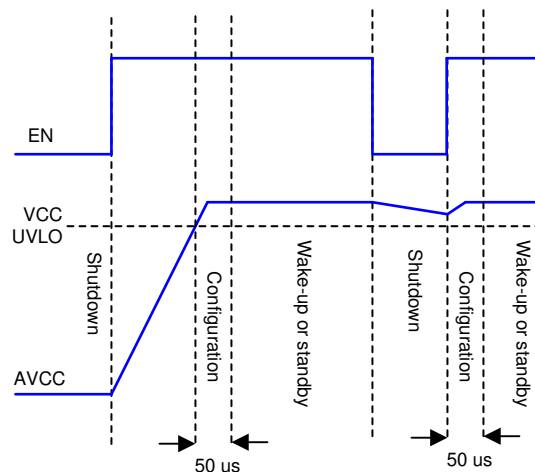
(1) If other output regulation targets are required, contact the sales office or distributors for availability.

### 8.3.4 Switching Frequency (RT Pin)

The switching frequency of the LM51501-Q1 is set by a single RT resistor connected between the RT and the AGND pins. The resistor value to set the switching frequency ( $F_{SW}$ ) is calculated using [方程式 1](#).

$$R_T = \frac{2.233 \times 10^{10}}{F_{SW\_RT(TYPICAL)}} - 619 \Omega \quad (1)$$

The RT pin is regulated to 1.2 V by the internal RT regulator during wake-up.

### 8.3.5 Clock Synchronization (SYNC Pin in SS Configuration)

In SS configuration, the switching frequency of the LM51501-Q1 can be synchronized to an external clock by directly applying a pulse signal to the SYNC pin. The internal clock of the LM51501-Q1 is synchronized at the rising edge of the external clock. The device ignores the rising edge input during forced off-time.

The external synchronization pulse must be greater than the 2.4 V in the high logic state and must be less than 0.4 V in the low logic state. The duty cycle of the external synchronization pulse is not limited, but the minimum pulse width should be greater than 100 ns. Because the maximum duty cycle limit and the peak current limit threshold are affected by synchronizing the switching frequency to an external synchronization pulse, take extra care when using the clock synchronization function. See [节 8.3.11](#) and [节 8.3.7](#) for more detailed information.

If the minimum input supply voltage of the boost converter is greater than  $\frac{1}{4}$  of the VOUT regulation target ( $V_{VOUT-REG}$ ), the frequency of the external synchronization pulse ( $F_{SYNC}$ ) should be within +15% and -15% of the typical free-running switching frequency ( $F_{SW(TYPICAL)}$ ) as shown in [方程式 2](#):

$$0.85 \times F_{SW\_RT(TYPICAL)} \leq F_{SYNC} \leq 1.15 \times F_{SW\_RT(TYPICAL)} \quad (2)$$

In this range, a maximum 1:4 ( $V_{SUPPLY}:V_{LOAD}$ ) step-up ratio is allowed.

A higher step-up ratio can be achieved by supplying a lower frequency synchronization pulse. 1:5 step-up ratio can be achieved by selecting  $F_{SYNC}$  within -25% and -15% of the  $F_{SW\_RT(TYPICAL)}$ .

$$0.75 \times F_{SW\_RT(TYPICAL)} \leq F_{SYNC} \leq 0.85 \times F_{SW\_RT(TYPICAL)} \quad (3)$$

In this range, a maximum 1:5 ( $V_{SUPPLY}:V_{LOAD}$ ) step-up ratio is allowed.

### 8.3.6 Current Sense, Slope Compensation, and PWM (CS Pin)

The LM51501-Q1 features low-side current sense amplifier with a gain of 10, and provides an internal slope compensation ramp to prevent subharmonic oscillation at high duty cycle. The device generates the slope compensation ramp using a sawtooth current source with a slope of  $30 \mu A \times F_{SW}$  (typical). This current flows through an internal 2-k $\Omega$  resistor and out of the CS pin. The slope compensation ramp is determined by the RT resistor and is  $60 \text{ mV} \times F_{SW}$  (typical) at the input of the current sense amplifier and  $600 \text{ mV} \times F_{SW}$  (typical) at the output of the current sense amplifier. The slope compensation ramp can be increased by adding an external slope resistor ( $R_{SL}$ ) between the sense resistor ( $R_S$ ) and the CS pin, but take extra care when using the  $R_{SL}$ , because the peak current limit is affected by adding  $R_{SL}$ . See [节 8.3.7](#) for more detailed information.



图 8-2. Current Sensing and Slope Compensation

According to peak current mode control theory, the slope of the compensation ramp must be greater than half of the sensed inductor current falling slope to prevent subharmonic oscillation at high duty cycle. Therefore, the minimum amount of slope compensation should satisfy the inequality in 方程式 4.

$$0.5 \times \frac{(V_{\text{LOAD}} + V_F) - V_{\text{SUPPLY}}}{L_M} \times R_S \times \text{Margin} < 30 \mu\text{A} \times (2\text{k}\Omega + R_{\text{SL}}) \times F_{\text{SW}} \quad (4)$$

$V_F$  is a forward voltage drop of D1, the external diode. 1.2 is recommended as a margin to cover non-ideal factors.

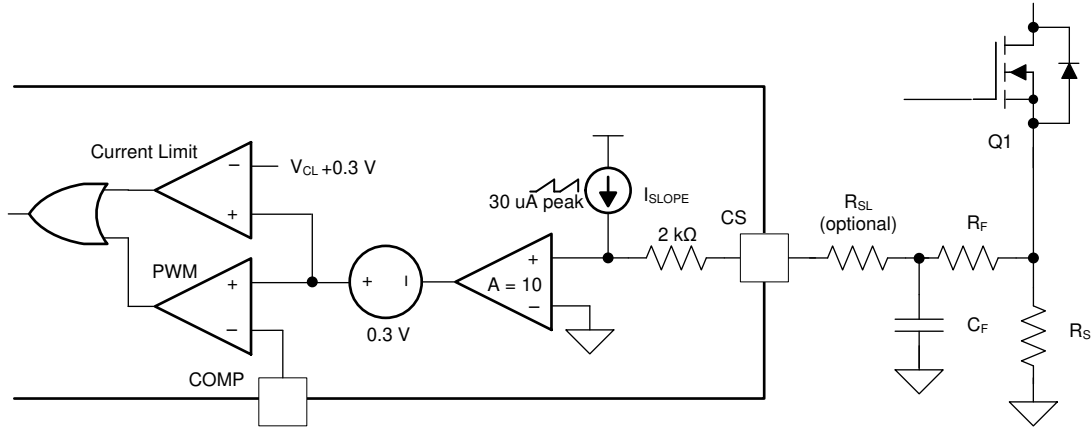
If required,  $R_{\text{SL}}$  can be added to increase the slope of the compensation ramp from half to 82% of the slope of the sensed inductor current during the falling slope. The typical  $R_{\text{SL}}$  value is calculated using 方程式 5. The maximum  $R_{\text{SL}}$  value is 1 k $\Omega$ .

$$0.82 \times \frac{(V_{\text{LOAD}} + V_F) - V_{\text{SUPPLY}}}{L_M} \times R_S = 30 \mu\text{A} \times (2\text{k}\Omega + R_{\text{SL}}) \times F_{\text{SW}} \quad (5)$$

The PWM comparator in 图 8-2 compares the sum of the sensed inductor current, the slope compensation ramp, and a 0.3-V (typical) internal COMP-to-PWM offset with the COMP pin voltage ( $V_{\text{COMP}}$ ), and will terminate the present cycle if the sum is greater than  $V_{\text{COMP}}$ .

### 8.3.7 Current Limit (CS Pin)

The LM51501-Q1 features cycle-by-cycle peak current limit without subharmonic oscillation at high duty cycle. If the sum of the sensed inductor current and the slope compensation ramp exceeds the current limit threshold at the current limit comparator input ( $V_{\text{CL}}$ ), the current limit comparator immediately terminates the present cycle. To minimize the peak current limit variation due to changes in either the supply voltage or the output voltage, the device features a variable current limit threshold which is calculated using 方程式 6.

$$V_{\text{CL}} = 1.2 + 0.6 \times \frac{(V_{\text{VOUT}} - V_{\text{VIN}})}{V_{\text{VOUT-REG}}} [\text{V}] \quad (6)$$

The cycle-by-cycle peak inductor current limit ( $I_{\text{PEAK-CL}}$ ) in steady-state is calculated using 方程式 7 and 方程式 8:

$$I_{\text{PEAK-CL}} = \frac{V_{\text{CL}} - 10 \times 30 \mu\text{A} \times (2\text{k}\Omega + R_{\text{SL}}) \times \frac{F_{\text{SW-RT}}}{F_{\text{SYNC}}} \times D}{10 \times R_S} \quad (7)$$

$$D = 1 - \frac{V_{\text{SUPPLY}}}{V_{\text{LOAD}} + V_F} \quad (8)$$

$F_{\text{SYNC}}$  is included in the equation because the peak amplitude of the slope compensation varies with the frequency of the external synchronization clock. Substitute  $F_{\text{SW\_RT}}$  for  $F_{\text{SYNC}}$  if clock synchronization is not used.

Boost converters have a natural pass-through path from the supply to the load through the high-side power diode (D1). Due to this path, boost converters cannot provide current limit protection when the output voltage is close to or less than the input supply voltage.

A small external RC filter ( $R_F$ ,  $C_F$ ) at the CS pin is required to overcome the leading edge spike of the current sense signal. Select an  $R_F$  value that is greater than 30  $\Omega$  and a  $C_F$  value that is greater than 1 nF. Due to the effect of the filter, the peak current limit is not valid when the on-time is less than  $2 \times R_F \times C_F$ .

### 8.3.8 Feedback and Error Amplifier (COMP Pin)

The LM51501-Q1 includes internal feedback resistors which are set based on the VSET pin resistor selection. These feedback resistors are disconnected from the VOUT pin in the standby mode to minimize quiescent current. The feedback resistor divider is connected to an internal transconductance error amplifier that features high output resistance ( $R_O = 10 \text{ M}\Omega$ ) and wide bandwidth ( $\text{BW} = 3 \text{ MHz}$ ). The internal transconductance error amplifier sources current which is proportional to the difference between the feedback resistor divider voltage and the internal reference. The output of the error amplifier is connected to the COMP pin, allowing the use of a Type-2 loop compensation network.

The  $R_{\text{COMP}}$ ,  $C_{\text{COMP}}$ , and the optional  $C_{\text{HF}}$  loop compensation components configure the error amplifier gain and phase characteristics to achieve a stable loop response. This compensation network creates a pole at very low frequency ( $F_{\text{DP}}$ ), a mid-band zero pole ( $F_{\text{Z\_EA}}$ ), and a high-frequency pole ( $F_{\text{P\_EA}}$ ). See 节 9.2.2.8 for more information.

### 8.3.9 Automatic Wake-Up and Standby

The LM51501-Q1 wakes up when  $V_{\text{VOUT}}$  drops below the VOUT wake-up threshold. The device goes into standby when  $V_{\text{VOUT}}$  rises above the VOUT standby threshold in EC or SS configuration or when  $V_{\text{VIN}}$  rises above the VIN standby threshold in SS configuration. The VOUT wake-up threshold is typically 3% higher than the VOUT regulation target. The STATUS output is released in 3  $\mu\text{s}$  (with 50-k $\Omega$  pullup resistor to 5 V) after the wake-up event. The LO driver is enabled 6  $\mu\text{s}$  after the STATUS output starts rising.



图 8-3. Automatic Wake-Up and Standby Control

LM51501-Q1

ZHC SHU0C - MARCH 2018 - REVISED OCTOBER 2021

In SS configuration, the VOUT standby threshold is typically 24% higher than the VOUT regulation target. The VIN standby threshold is typically 1 V higher than the VOUT wake-up threshold in SS configuration. To prevent chatter, the forward voltage drop of diode D1 must be less than 0.95 V. See 图 8-7.

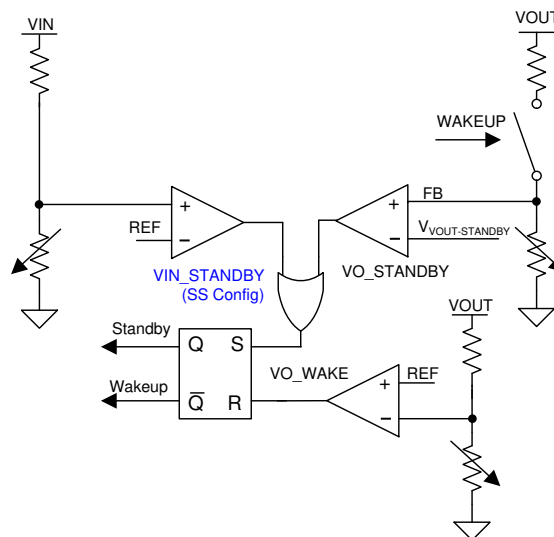

图 8-4. Automatic Wake-Up and Standby Operation in the SS Configuration (With Fast  $V_{SUPPLY}$  Fall and Slow Switching)



图 8-5. Automatic Wake-Up and Standby Operation in the SS Configuration (With Slow  $V_{SUPPLY}$  Fall and Fast Switching)

In EC configuration, the VOUT standby threshold is typically 6% higher than the VOUT regulation target. Because of the minimum duty cycle limit (see 节 8.4.3.2 section), the LM51501-Q1 alternates between the wake-up and the low  $I_Q$  standby modes at medium or light load. See 图 8-8.

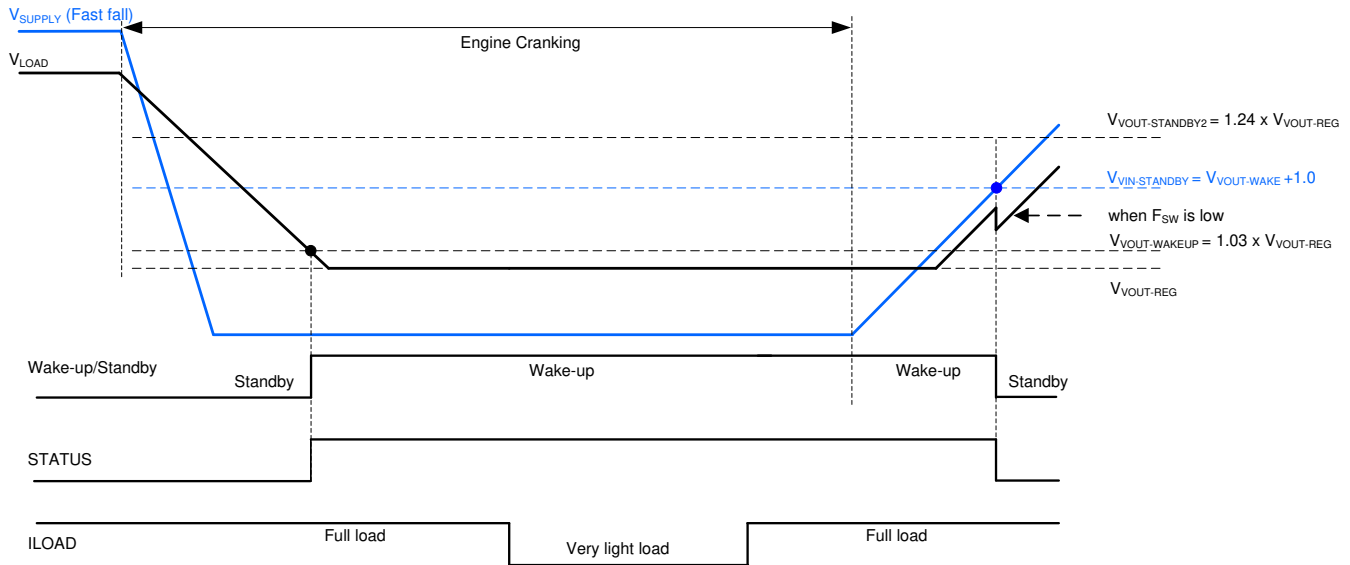

图 8-6. Automatic Wake-Up and Standby Operation in EC Configuration

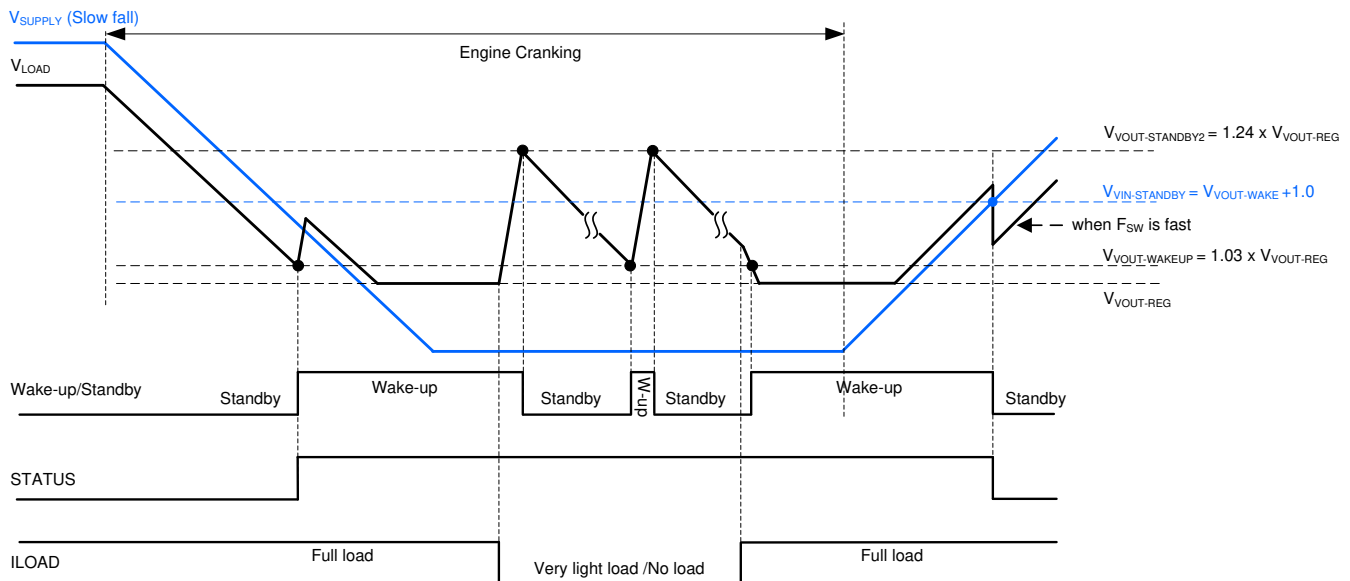
To minimize output undershoot when waking up, the LM51501-Q1 boosts the VOUT regulation target during the first 128 cycles after the wake-up event. The regulation target becomes 3% higher than the original regulation target for 64 cycles, 2% higher for the next 32 cycles, and 1% higher for the final 32 cycles. The VOUT pin voltage can rise up above the VOUT standby threshold, even if switching stops at the VOUT standby threshold, because the energy stored in the inductor transfers to the output capacitor when switching stops. See 节 8.4 for more information about the automatic wake-up and standby operation.

### 8.3.10 Boost Status Indicator (STATUS Pin)

STATUS is an open-drain output and requires a pullup resistor between 5 kΩ and 100 kΩ. The pin is pulled up after V<sub>VOUT</sub> falls below the VOUT wake-up threshold, and is toggled to a low logic state when V<sub>VIN</sub> rises above the VIN standby threshold in SS configuration or when V<sub>VOUT</sub> rises above the VOUT status off-threshold in EC configuration. The pin is also pulled to ground when EN < 1 V and VOUT is greater than about 2 V, when AVCC < V<sub>VCC-UVLO-FALLING</sub> or during thermal shutdown.

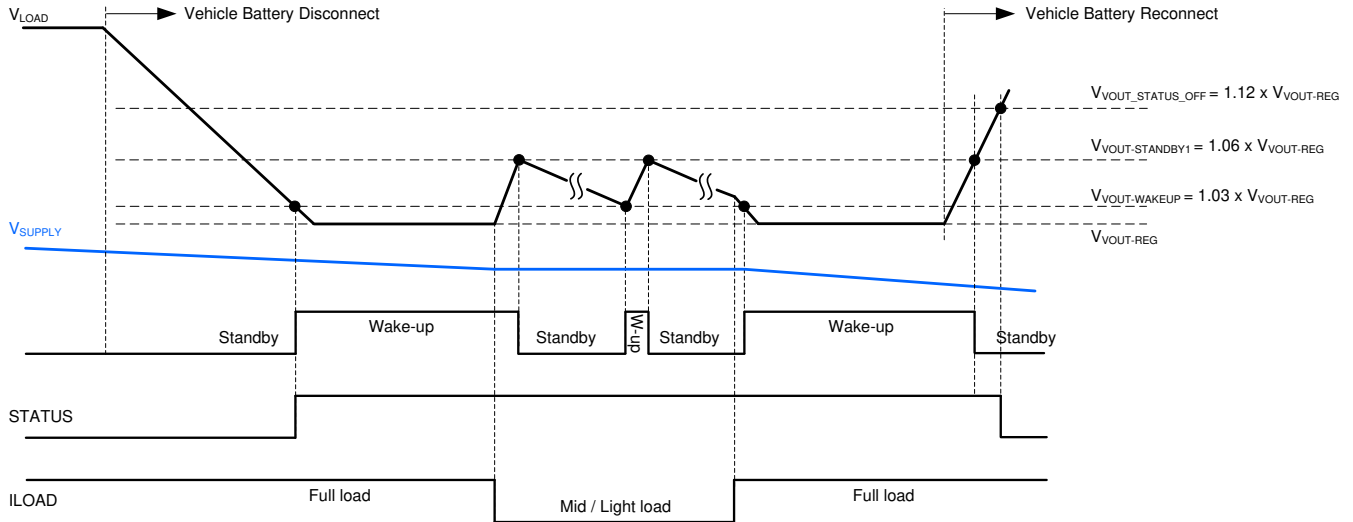
### 8.3.11 Maximum Duty Cycle Limit and Minimum Input Supply Voltage

When designing a boost converter, the maximum duty cycle should be reviewed at the minimum supply voltage. The minimum input supply voltage which can achieve the target output voltage is estimated from 方程式 9.

$$V_{\text{SUPPLY(MIN)}} \approx (V_{\text{VOUT-REG}} + V_F) \times (1 - D_{\text{MAX}}) \times \frac{F_{\text{SYNC}}}{F_{\text{SW\_RT}}} + I_{\text{SUPPLY(MAX)}} \times R_{\text{DCR}} + I_{\text{SUPPLY(MAX)}} \times (R_{\text{DS(ON)}} + R_S) \times D_{\text{MAX}} \quad (9)$$

where

- I<sub>SUPPLY(MAX)</sub> is the maximum input current.
- R<sub>DCR</sub> is the DC resistance of the inductor.
- and R<sub>DS(ON)</sub> is the on-resistance of the MOSFET.

Substitute F<sub>SW\_RT</sub> for F<sub>SYNC</sub> if clock synchronization is not used. The minimum input supply voltage can be decreased by supplying F<sub>SYNC</sub> because it is less than F<sub>SW\_RT</sub>.

This maximum duty cycle limit (D<sub>MAX</sub>) is 87% (typical), but may fall down below 80% if the external synchronization clock frequency is higher than 0.85 × F<sub>SW(TYPICAL)</sub>. Select an F<sub>SYNC</sub> that is within - 25% and - 15% of the F<sub>SW(TYPICAL)</sub> if 1:5 step-up ratio is required for clock synchronization. The minimum input supply voltage can be further decreased by supplying a lower frequency external synchronization clock. See 节 8.3.5 for more information.

### 8.3.12 MOSFET Driver (LO Pin)

The LM51501-Q1 provides an N-channel MOSFET driver that can source or sink a peak current of 1.5 A. The driver is powered by the 5-V VCC regulator and is enabled when the EN pin voltage is greater than 2 V and the AVCC pin voltage is greater than the AVCC UVLO threshold.

### 8.3.13 Thermal Shutdown

Internal thermal shutdown is provided to protect the LM51501-Q1 if the junction temperature exceeds 175°C (typical). When thermal shutdown is activated, the device is forced into a low power thermal shutdown state with the MOSFET driver and the VCC regulator is disabled. After the junction temperature is reduced (typical hysteresis is 15°C), the device is re-enabled.

## 8.4 Device Functional Modes

### 8.4.1 Shutdown Mode

If the EN pin voltage is below 1 V, the LM51501-Q1 is in shutdown mode with all functions disabled except the EN. In shutdown mode, the device reduces the VOUT pin current consumption to below 5  $\mu$ A (typical) and the STATUS pin is pulled to ground. The device can be enabled by raising the EN pin above 2 V and operates in either standby mode or the wake-up mode if  $V_{AVCC}$  is greater than the AVCC UVLO threshold.

表 8-2. State of Each Pin in Shutdown Mode

STATUS	SYNC	RT	COMP	EN	VOUT	PVCC/AVCC	LO	CS	VIN	VSET
Grounded	Disabled	Disabled	Disabled	Enabled	$I_Q \leq 5 \mu\text{A}$	Disabled	Grounded	Disabled	$I_Q \approx 0.1 \mu\text{A}$	Disabled

### 8.4.2 Standby Mode

If VOUT is greater than the VOUT standby threshold or the VIN is greater than the VIN standby threshold in the SS mode, the LM51501-Q1 enters into standby mode.

In standby mode, most functions are disabled, including the thermal shutdown, to minimize the current consumption. The VOUT wake-up monitor is enabled in standby mode to allow wake-up if the VOUT voltage drops below the VOUT wake-up threshold. The VCC regulator reduces the sourcing capability to 17 mA in standby mode and the AVCC UVLO comparator is disabled.

The VOUT standby threshold fulfills effectively the overvoltage protection (OVP) function.

表 8-3. State of Each Pin in Standby Mode

STATUS	SYNC	RT	COMP	EN	VOUT	PVCC/AVCC	LO	CS	VIN	VSET
Released or Grounded	Disabled	Disabled	Disabled	Enabled	$I_Q \leq 15 \mu\text{A}$ . VOUT wake-up monitor enabled	Enabled $I_{PVCC}$ capability $\approx 17 \text{ mA}$	Grounded	Disabled	$I_Q \approx 0.1 \mu\text{A}$	Disabled

### 8.4.3 Wake-Up Mode

The LM51501-Q1 wakes up from standby mode if VOUT drops below the VOUT wake-up threshold. There are two configurations when the device wakes up. One is start-stop configuration (SS configuration) and the other is emergency-call configuration (EC configuration). The configuration is selectable by the VSET resistor (see [表 8-1](#)).

### 8.4.3.1 Start-Stop Configuration (SS Configuration)



图 8-7. Typical Start-Stop Application

The LM51501-Q1 runs at fixed switching frequency without any pulse skipping in SS configuration. The device turns on the LO driver every cycle with  $T_{ON-MIN}$  until it enters standby mode, which helps to prevent EMI spectrum shifts. Because the MOSFET turns on every cycle, the boost converter output may be above the regulation target if the required on-time is less than the  $T_{ON-MIN}$  when the boost supply voltage is close to the  $V_{OUT}$  regulation target or the load current is very small. The output voltage will rise above the  $V_{OUT}$  regulation target if the one of the inequalities listed in [方程式 10](#) or [方程式 11](#) is true.

$$D \times \frac{1}{F_{SW}} < T_{ON-MIN} \quad (10)$$

$$\frac{(V_{SUPPLY} \times T_{ON-MIN})^2}{2 \times L_M} \times \frac{F_{SW}}{(V_{LOAD} + V_F - V_{SUPPLY})} > I_{LOAD} \quad (11)$$

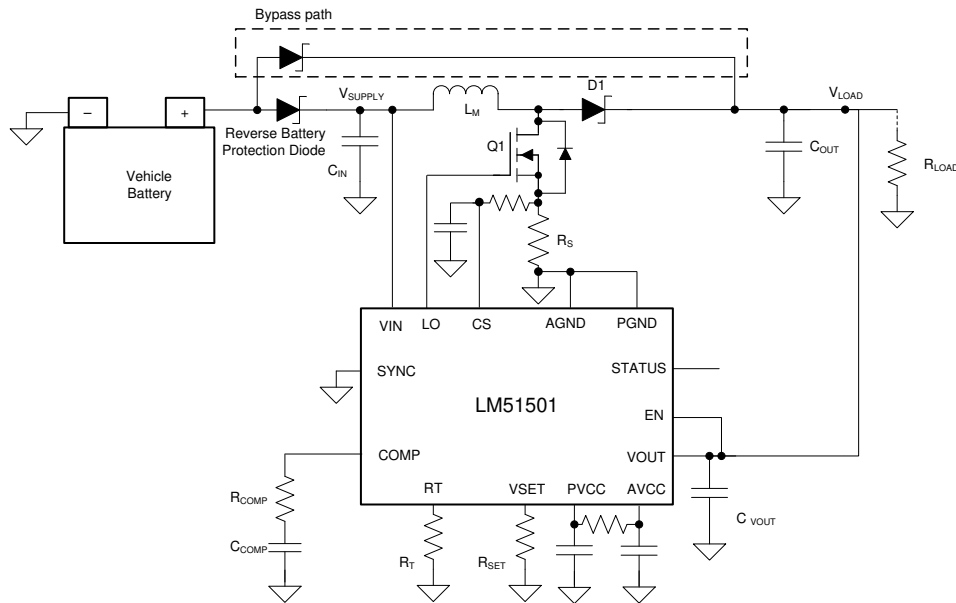
In SS configuration, the LM51501-Q1 enters into the standby mode if  $V_{OUT}$  is greater than the  $V_{OUT}$  standby threshold—which is 24% higher than the  $V_{OUT}$  regulation target—or if  $V_{IN}$  is greater than the  $V_{IN}$  standby threshold.

### 8.4.3.2 Emergency-Call Configuration (EC Configuration)



图 8-8. Typical Emergency Call Application

The EC configuration achieves high efficiency at light or medium load by alternating between the wake-up and the low  $I_Q$  standby modes. In EC configuration, the LM51501-Q1 limits the minimum duty cycle programmed by  $V_{VOUT}$  and  $V_{VIN}$ . The minimum duty cycle limit is calculated using 方程式 12.

$$D_{MIN} = 0.75 \times \left( 1 - \frac{V_{VIN}}{V_{VOUT-REG}} \right) \quad (12)$$

Due to this minimum duty cycle limit, the boost converter sources more current than required when the load current is relatively small. As a result, the output voltage increases and eventually crosses the  $V_{OUT}$  standby threshold which is typically 6% higher than the  $V_{OUT}$  regulation target. The LM51501-Q1 then goes into the low  $I_Q$  standby mode. The LM51501-Q1 wakes up when  $V_{OUT}$  drops below the  $V_{OUT}$  wake-up threshold which is typically 3% higher than the  $V_{OUT}$  regulation target. The device alternates between these two modes when the inequality in 方程式 13 is true.

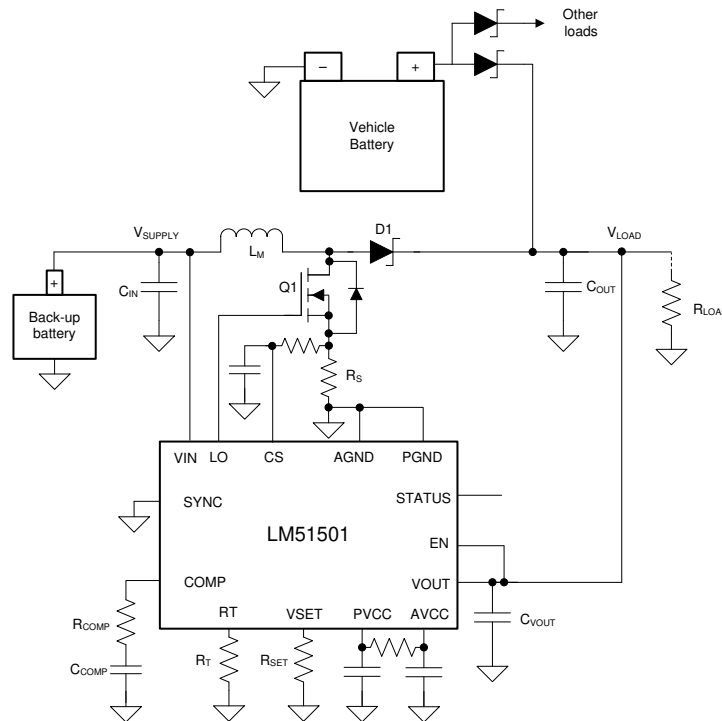
$$\frac{\left( V_{SUPPLY} \times \frac{D_{MIN}}{F_{SW}} \right)^2}{2 \times L_M} \times \frac{F_{SW}}{(V_{LOAD} + V_F - V_{SUPPLY})} > I_{LOAD} \quad (13)$$

Assuming  $V_{LOAD} = V_{VOUT} = V_{VOUT-REG}$  and  $V_{SUPPLY} = V_{VIN}$ , the skip cycle operation starts when the inequality in 方程式 14 is true.

$$\frac{\left( V_{SUPPLY} \times 0.75 \times \left( \frac{V_{LOAD} - V_{SUPPLY}}{V_{LOAD}} \right) \right)^2}{2 \times L_M \times F_{SW} \times (V_{LOAD} + V_F - V_{SUPPLY})} > I_{LOAD} \quad (14)$$

In EC configuration, the LM51501-Q1 does not generate any pulse if  $V_{COMP}$  is less than the 0.3 V and the required minimum duty cycle limit is zero.

If the peak current limit is triggered before reaching the minimum duty cycle, the device terminates the LO driver output immediately.

If  $V_{OUT}$  is greater than the  $V_{OUT}$  status-off threshold (typically 12% higher than the  $V_{OUT}$  regulation target), the LM51501-Q1 pulls the STATUS pin low.

In EC configuration, light-load efficiency is proportional with the inductor current ripple ratio.

**表 8-4. State of Each Pin in Wake-Up Mode**

STATUS	SYNC	RT	COMP	EN	VOUT	PVCC/AVCC	LO	CS	VIN	VSET
Released	Enabled in SS configuration	Enabled	Enabled	Enabled	VOUT standby monitor is enabled. VOUT status-off monitor is enabled in EC configuration.	Enabled $I_{PVCC}$ capability $\approx 75$ mA	PWM	Enabled	$I_Q \approx 30$ $\mu$ A. VIN status-off monitor is enabled in SS configuration	Disabled

**表 8-5. Start-Stop vs Emergency-Call Configuration**

CONFIGURATION	START-STOP	EMERGENCY-CALL
VOUT regulation options	6.0 V, 6.5 V, 9.5 V, 11.5 V	
VSET resistor value [ $\Omega$ ]	29.4k, 19.1k, 9.53k, GND	90.9k, 71.5k, 54.9k, 41.2k
Clock Synchronization	Yes	No, SYNC should be grounded
VOUT wake-up threshold [V]	$V_{VOUT-REG} \times 1.03$	
VOUT standby threshold [V]	$V_{VOUT-REG} \times 1.24$	$V_{VOUT-REG} \times 1.06$
VOUT status-off threshold [V]	N/A	$V_{VOUT-REG} \times 1.12$
VIN standby threshold [V]	$V_{VOUT-REG} \times 1.03 + 1.0$ V	N/A
STATUS pin control (Open-drain with pullup resistor)	Released by VOUT wake-up Pulled down by VIN standby	Released by VOUT wake-up Pulled down by VOUT status-off
At heavy load when $V_{VIN} \ll V_{VOUT}$	Pulse width modulation (PWM)	
At light or no load when $V_{VIN} \ll V_{VOUT}$	LO turns on at every cycle in wake-up configuration. Skip cycle operation by alternating between wake-up and standby configurations.	
	Minimum on-time is limited	Minimum duty cycle is limited
When $V_{VIN} \approx V_{VOUT}$ or $V_{VIN} \geq V_{VOUT}$	LO turns on at every cycle in wake-up configuration. On-time is limited by $T_{ON-MIN}$ . VOUT goes out of regulation.	Duty cycle can drop to 0%. No pulses if $V_{COMP} < 0.3$ V and $D_{MIN} \leq 0\%$ .
Maximum duty-cycle limit	Typically 87%	

## 9 Application and Implementation

### Note

以下应用部分中的信息不属于 TI 器件规格的范围，TI 不担保其准确性和完整性。TI 的客户应负责确定器件是否适用于其应用。客户应验证并测试其设计，以确保系统功能。

### 9.1 Application Information

The LM51501-Q1 is a non-synchronous boost controller. The following design procedure can be used to select the external components for the LM51501-Q1. Alternately, the WEBENCH® software can be used to generate complete designs. The WEBENCH software uses an iterative design procedure and accesses comprehensive data bases of components when generating a design. This section presents a simplified discussion of the design process.

#### 9.1.1 Bypass Switch / Disconnection Switch Control

The STATUS pin can be used to control an external bypass switch, which turns on when the boost is in standby mode, or to control an external disconnection switch that turns off when the boost is in standby mode. In [图 9-1](#), a P-channel MOSFET is used to connect the boost supply input to the load directly when the boost is in standby mode. This bypass switch can be turned on slowly, but it must be turned off fast after the STATUS pin is pulled up by the wake-up event. The STATUS pin is rated to the absolute maximum 65 V.



图 9-1. Bypass Switch Control Example

In [图 9-2](#), a P-channel MOSFET is used to disconnect the boost supply output from the battery when boost is not required. This disconnection switch can be turned off slowly, but it must be turned on fast after the STATUS pin is pulled up by the wake-up event.

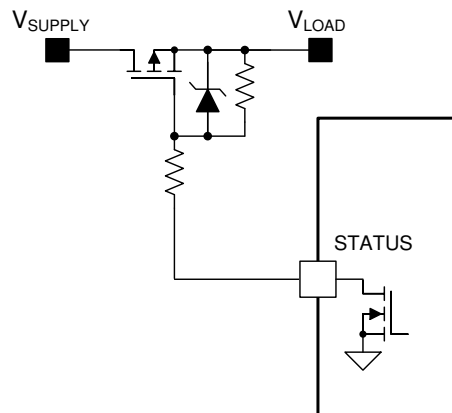

图 9-2. Disconnection Switch Control Example

### 9.1.2 Loop Response

The open-loop transfer function of a boost regulator is defined as the product of modulator transfer function and feedback transfer function.

The modulator transfer function of a current mode boost regulator including a power stage with an embedded current loop can be simplified as a one load pole ( $F_{LP}$ ), one ESR zero ( $F_{Z\_ESR}$ ), and one Right Half Plane (RHP) zero ( $F_{RHP}$ ) system, which can be explained as follows.

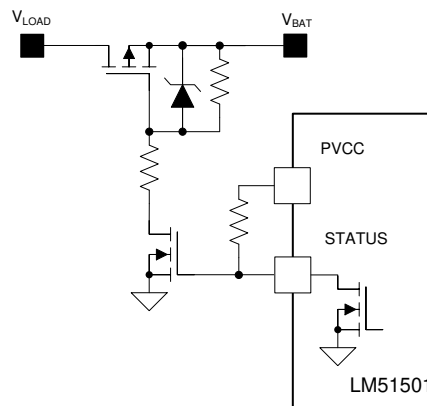
Modulator transfer function is defined as [方程式 15](#):

$$\frac{\hat{V}_{LOAD}(s)}{\hat{V}_{COMP}(s)} = A_M \times \frac{\left(1 + \frac{s}{2\pi \times F_{Z\_ESR}}\right) \times \left(1 - \frac{s}{2\pi \times F_{RHP}}\right)}{\left(1 + \frac{s}{2\pi \times F_{LP}}\right)} \quad (15)$$

where

- $A_M = \frac{R_{LOAD}}{R_S \times 10} \times \frac{D'}{2}$
- $F_{LP} = \frac{2}{2\pi \times R_{LOAD} \times C_{OUT}} \text{ [Hz]}$
- $F_{Z\_ESR} = \frac{1}{2\pi \times R_{ESR} \times C_{OUT}} \text{ [Hz]}$
- $F_{RHP} = \frac{R_{LOAD} \times (D')^2}{2\pi \times L_M} \text{ [Hz]}$

$R_{ESR}$  is the equivalent series resistance (ESR) of the output capacitor which is specified in the capacitor data sheet.

$R_{COMP}$ ,  $C_{COMP}$ , and  $C_{HF}$  (see [图 9-3](#)) configure the error amplifier gain and phase characteristics to produce a stable voltage loop with fast response. This compensation network creates a dominant pole at low frequency ( $F_{DP\_EA}$ ), a mid-band zero pole ( $F_{Z\_EA}$ ), and a high frequency pole ( $F_{P\_EA}$ ).

The feedback transfer function is defined as [方程式 16](#):

$$-\frac{\hat{V}_{\text{COMP}}(s)}{\hat{V}_{\text{LOAD}}(s)} = A_{\text{FB}} \times \frac{\left(1 + \frac{s}{2\pi \times F_{\text{Z\_EA}}}\right)}{\left(1 + \frac{s}{2\pi \times F_{\text{DP\_EA}}}\right) \times \left(1 + \frac{s}{2\pi \times F_{\text{P\_EA}}}\right)} \quad (16)$$

where

- $A_{\text{FB}} = \frac{1.2}{V_{\text{LOAD}}} \times R_{\text{O}} \times G_{\text{m}}$
- $F_{\text{DP\_EA}} = \frac{1}{2\pi \times R_{\text{O}} \times C_{\text{COMP}}} \text{ [Hz]}$
- $F_{\text{Z\_EA}} = \frac{1}{2\pi \times R_{\text{COMP}} \times C_{\text{COMP}}} \text{ [Hz]}$
- $F_{\text{P\_EA}} = \frac{1}{2\pi \times R_{\text{COMP}} \times \left(\frac{C_{\text{COMP}} \times C_{\text{HF}}}{C_{\text{COMP}} + C_{\text{HF}}}\right)} \approx \frac{1}{2\pi \times R_{\text{COMP}} \times C_{\text{HF}}} \text{ [Hz]}$

$R_{\text{O}}$  ( $\approx 10 \text{ M}\Omega$ ) is the output resistance of the error amplifier and  $G_{\text{m}}$  ( $\approx 2 \text{ mA/V}$ ) is the transconductance of the error amplifier.

Assuming  $F_{\text{LP}}$  is canceled by  $F_{\text{Z\_EA}}$ ,  $F_{\text{RHP}}$  is much higher than crossover frequency ( $F_{\text{CROSS}}$ ), and if  $F_{\text{Z\_ESR}}$  is either canceled by  $F_{\text{P\_EA}}$  or  $F_{\text{Z\_ESR}}$ , then that is much higher than  $F_{\text{CROSS}}$ . The open-loop transfer function can be simplified as [方程式 17](#):

$$T(s) = A_{\text{M}} \times A_{\text{FB}} \times \frac{1}{\left(1 + \frac{s}{2\pi \times F_{\text{DP\_EA}}}\right)} \quad (17)$$

Because  $|T(s)|=1$  at the crossover frequency, the crossover frequency can be simply estimated using those assumptions.

$$F_{\text{CROSS}} \approx \frac{\sqrt{[A_{\text{M}} \times A_{\text{FB}}]^2 - 1}}{2\pi \times R_{\text{O}} \times C_{\text{COMP}}} \text{ [Hz]} \quad (18)$$

## 9.2 Typical Application

The LM51501 requires a minimum number of external components to work. 图 9-3 includes all optional components as an example.



图 9-3. Typical Circuit With Optional Components

### 9.2.1 Design Requirements

表 9-1 lists the design parameters for 图 9-3.

表 9-1. Design Example Parameters

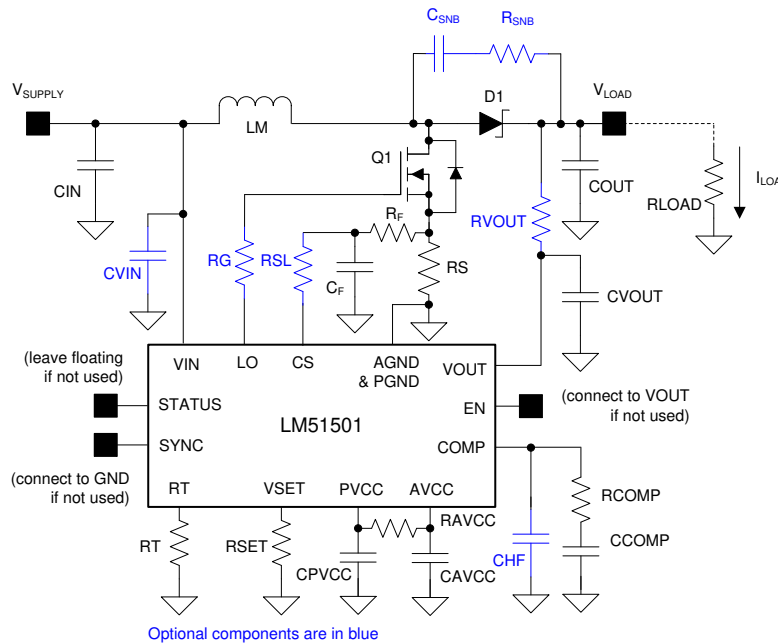
DESIGN PARAMETER	VALUE
Target Application	Start-stop
Minimum Input Supply Voltage ( $V_{SUPPLY(MIN)}$ )	2.5 V
Target Output Voltage ( $V_{LOAD}$ )	9.5 V
Maximum Load Current ( $I_{LOAD}$ )	2.6 A ( $\approx$ 25 Watt)
Switching Frequency ( $F_{SW}$ )	440 kHz
D1 Diode Forward Voltage Drop	0.7 V
Maximum Inductor Current Ripple Ratio (RR)	0.6 (= 60%)
Estimated Full Load Efficiency (Eff)	0.8 (= 80%)
Current Limit Margin ( $M_{CL}$ )	1.2 (= 120%)
$F_{LP}$ over $F_{CROSS}$ (K1)	0.18 ( $F_{LP} = 0.18 \times F_{CROSS}$ )
$F_{Z_{EA}}$ over $F_{LP}$ (K2)	3 ( $F_{Z_{EA}} = 3 \times F_{LP}$ )

### 9.2.2 Detailed Design Procedure

#### 9.2.2.1 Custom Design With WEBENCH® Tools

[Click here](#) to create a custom design using the LM51501-Q1 device with the WEBENCH® Power Designer.

1. Start by entering the input voltage ( $V_{IN}$ ), output voltage ( $V_{OUT}$ ), and output current ( $I_{OUT}$ ) requirements.
2. Optimize the design for key parameters such as efficiency, footprint, and cost using the optimizer dial.
3. Compare the generated design with other possible solutions from Texas Instruments.

The WEBENCH Power Designer provides a customized schematic along with a list of materials with real-time pricing and component availability.

In most cases, these actions are available:

- Run electrical simulations to see important waveforms and circuit performance
- Run thermal simulations to understand board thermal performance
- Export customized schematic and layout into popular CAD formats
- Print PDF reports for the design, and share the design with colleagues

Get more information about WEBENCH tools at [www.ti.com/WEBENCH](http://www.ti.com/WEBENCH).

### 9.2.2.2 $R_{SET}$ Resistor

Select the value of  $R_{SET}$ . Referring to 表 8-1, 9.53 k $\Omega$  is chosen to target 9.5 V in SS configuration. In general, about 5% to approximately 10% output undershoot should be considered when selecting the VOUT regulation target.

### 9.2.2.3 $R_T$ Resistor

The value of  $R_T$  for 440-kHz switching frequency is calculated in 方程式 19:

$$R_T = \frac{2.233 \times 10^{10}}{F_{SW\_RT(TYPICAL)}} - 619 = \frac{2.233 \times 10^{10}}{440 \text{ k}} - 619 = 50.1 \text{ k}\Omega \quad (19)$$

A standard value of 49.9 k $\Omega$  is chosen for  $R_T$ .

In general, higher frequency boost converters are smaller and faster, but they also have higher switching losses and lower efficiency.

### 9.2.2.4 Inductor Selection ( $L_M$ )

When selecting the inductor, consider three key parameters: inductor current ripple ratio (RR), falling slope of the inductor current, and RHP zero frequency ( $F_{RHP}$ ).

Inductor current ripple ratio is selected to have a balance between core loss and copper loss. The falling slope of the inductor current must be low enough to prevent subharmonic oscillation at high duty cycle (additional  $R_{SL}$  resistor is required, if not). Higher  $F_{RHP}$  (= lower inductance) allows a higher crossover frequency and is always preferred when using a smaller value output capacitor.

The inductance value can be selected to set the inductor current ripple between 30% and 70% of the average inductor current as a good compromise between RR,  $F_{RHP}$ , and inductor falling slope. In this example, 60% ripple ratio (RR = 0.6) is selected as the maximum inductor current ripple ratio (the inductor current ripple ratio is the biggest when D = 0.33). The target inductance value is calculated using 方程式 20:

$$L_{M(TARGET)} = \frac{0.14 \times R_{LOAD}}{RR \times F_{SW}} = \frac{0.14 \times \frac{9.5}{2.6}}{0.6 \times 440 \text{ k}} = 1.94 \mu\text{[H]} \quad (20)$$

$$L_{M(GUIDE)} = \frac{(V_{LOAD} - V_{SUPPLY(MIN)}) \times V_{SUPPLY(MIN)}}{F_{SW} \times V_{LOAD} \times I_{LOAD}} = \frac{(9.5 - 2.5) \times 2.5}{440 \text{ k} \times 9.5 \times 2.6} = 1.61 \mu\text{[H]} \quad (21)$$

If the target inductance is smaller than the value calculated using 方程式 20, consider adding the slope compensation resistor ( $R_{SL}$ ), as mentioned in 节 9.2.2.6, or select a smaller RR and recalculate the inductance using 方程式 21.

A standard value of 2.2  $\mu\text{H}$  is chosen for  $L_M$ . The required inductor saturation current rating is estimated after selecting  $R_S$  and  $R_{SL}$ .

### 9.2.2.5 Current Sense ( $R_S$ )

Based on the assumptions that 20% of current limit margin ( $M_{CL} = 1.2$ ), 80% estimated efficiency ( $Eff = 0.8$ ) at full load and no  $R_{SL}$  populated,  $R_S$  is calculated using 方程式 22 and 方程式 23.

$$R_S = \frac{1.2 + 0.6 \times \frac{(V_{VOULT} - V_{VIN})}{V_{VOULT-REG}} - 10 \times 30\mu A \times (2k\Omega + R_{SL}) \times \frac{F_{SW\_RT}}{F_{SYNC}} \times D}{10 \times \left( \frac{V_{LOAD} \times I_{LOAD}}{V_{SUPPLY(MIN)} \times Eff} + \frac{1}{2} \times \frac{V_{SUPPLY(MIN)} \times D \times \frac{1}{F_{SYNC}}}{L_M} \right) \times M_{CL}} \quad [\Omega] \quad (22)$$

$$R_S = \frac{1.2 + 0.6 \times \frac{(9.5 - 2.5)}{9.5} - 10 \times 30 \mu \times (2k + 0) \times 1 \times \left( 1 - \frac{2.5}{9.5 + 0.7} \right)}{10 \times \left( \frac{9.5 \times 2.6}{2.5 \times 0.8} + \frac{1}{2} \times \frac{2.5 \times \left( 1 - \frac{2.5}{9.5 + 0.7} \right) \times \frac{1}{440k}}{2.2 \mu} \right) \times 1.3} = 7.44 \text{ m}[\Omega] \quad (23)$$

Substitute  $F_{SW\_RT}$  for  $F_{SYNC}$  if clock synchronization is not used.

A standard value of 7 mΩ is chosen for  $R_S$ . A low-ESL resistor is recommended to minimize the error caused by the ESL.

### 9.2.2.6 Slope Compensation Ramp ( $R_{SL}$ )

The minimum inductance value, which can prevent subharmonic oscillation without  $R_{SL}$ , is calculated using 方程式 24. If the selected inductance value is less than the minimum inductance calculated using 方程式 24, add a slope compensation resistor ( $R_{SL}$ ) externally.

$$L_{M(MIN)} = 0.5 \times \frac{(V_{LOAD} + V_F) - V_{SUPPLY(MIN)}}{60 \text{ m} \times F_{SW}} \times R_S \times \text{Margin} = 0.5 \times \frac{(9.5 + 0.7) - 2.5}{60 \text{ m} \times 440 \text{ k}} \times 7 \text{ m} \times 1.2 = 1.22 \mu[\text{H}] \quad (24)$$

1.2 is the recommended margin to cover non-ideal factors.

If needed, use 方程式 25 to find the  $R_{SL}$  value which matches the typical amount of slope compensation.

$$R_{SL} = 0.82 \times \frac{(V_{LOAD} + V_F) - V_{SUPPLY(MIN)}}{L_M \times F_{SW} \times 30\mu A} \times R_S - 2k[\Omega] \quad (25)$$

In this example,  $R_{SL}$  is not populated because the selected inductance value, 2.2 μH, is greater than the minimum required inductance from 方程式 24.

After selecting  $R_S$  and  $R_{SL}$ , the peak inductor current at current limit ( $I_{PEAK-CL}$ ) can be calculated. Setting the inductor saturation current rating higher than the  $I_{PEAK-CL}$  is recommended.

$$I_{PEAK-CL} = \frac{V_{CL} - 10 \times 30\mu A \times (2k\Omega + R_{SL}) \times \frac{F_{SW\_RT}}{F_{SYNC}} \times D}{10 \times R_S} + \frac{V_{SUPPLY(MIN)}}{L_M} \times T_D[\text{A}] \quad (26)$$

$$I_{PEAK-CL} = \frac{1.2 + 0.6 \times \frac{(9.5 - 2.5)}{9.5} - 10 \times 30 \mu \times 2k \times 1 \times \left( 1 - \frac{2.5}{9.5 + 0.7} \right)}{10 \times 7 \text{ m}} + \frac{2.5}{2.2 \mu} \times 20 \text{ n} = 17.0 [\text{A}] \quad (27)$$

$T_D$  is the typical propagation delay of current limit.

### 9.2.2.7 Output Capacitor ( $C_{OUT}$ )

There are a few ways to select the proper value of output capacitor ( $C_{OUT}$ ). The output capacitor value can be selected based on output voltage ripple, output overshoot, or output undershoot due to load transient. In this example,  $C_{OUT}$  is selected based on output undershoot because the wake-up performance is similar with no-load to full-load transient performance.

The output undershoot becomes smaller by increasing  $F_{CROSS}$  or by decreasing  $F_{LP}$ . A smaller  $C_{OUT}$  is allowed by increasing  $F_{CROSS}$  or by decreasing  $F_{LP}$ .

To increase  $F_{CROSS}$ ,  $F_{SW}$  and  $F_{RHP}$  must be increased because the maximum  $F_{CROSS}$  is, in general, limited at 1/10 of  $F_{RHP}$  at  $V_{SUPPLY(MIN)}$  or 1/10 of  $F_{SW}$ , whichever is lower.

$F_{RHP}$  is calculated using [方程式 28](#).

$$F_{RHP} = \frac{R_{LOAD} \times \left( \frac{V_{SUPPLY(MIN)}}{V_{LOAD} + V_F} \right)^2}{2\pi \times L_M} = \frac{9.5}{2.6} \times \left( \frac{2.5}{9.5 + 0.7} \right)^2 = 15.9 \text{ k[HZ]} \quad (28)$$

$F_{CROSS}$  is selected at 1/10 of  $F_{RHP}$  or 1/10 of  $F_{SW}$ , whichever is lower.

$$\frac{F_{RHP}}{10} = 1.59 \text{ k[HZ]} \quad (29)$$

$$\frac{F_{SW}}{10} = \frac{440 \text{ k}}{10} = 44 \text{ k[HZ]} \quad (30)$$

In this example, 1.59 kHz is selected as a target  $F_{CROSS}$  and  $F_{LP}$  is selected to be 286 Hz ( $K1 = 0.18$ ).

In general, there is about 5% or less undershoot with  $F_{LP} = 0.1 \times F_{CROSS}$  ( $K1 = 0.1$ ) and 10% or less undershoot with  $F_{LP} = 0.2 \times F_{CROSS}$  ( $K1 = 0.2$ ) during 0% to 100% load transient. The recommended  $K1$  factor range is from 0.02 to 0.2.

$F_{LP}$  is calculated using [方程式 31](#).

$$F_{LP} = \frac{2}{2\pi \times R_{LOAD} \times C_{OUT}} \text{ [Hz]} \quad (31)$$

The minimum required output capacitance value is calculated using [方程式 32](#).

$$C_{OUT} = \frac{2}{2\pi \times R_{LOAD} \times F_{LP}} = \frac{2}{2\pi \times \frac{9.5}{2.6} \times 286} = 304 \mu\text{[F]} \quad (32)$$

The maximum output ripple current is calculated at the minimum input supply voltage using [方程式 33](#):

$$I_{RIPPLE\_COUT(MAX)} = \frac{V_{LOAD} \times I_{LOAD}}{2 \times V_{SUPPLY(MIN)}} = \frac{9.5 \times 2.6}{2 \times 2.5} = 4.9 \text{ [A]} \quad (33)$$

The ripple current rating of the output capacitors must be enough to handle the output ripple current. By using multiple output capacitors, the ripple current can be split. In practice, ceramic capacitors are placed closer to the diode and the MOSFET than the bulk aluminum capacitors to absorb the majority of the ripple current.

In this example, three 100-μF capacitors are placed in parallel to ensure ripple current capability. If high-ESR capacitors are used for the output capacitor, additional 10-μF ceramic capacitors can be placed close to the switching components to minimize switching noise.

### 9.2.2.8 Loop Compensation Component Selection and Maximum ESR

Based on 方程式 18,  $C_{COMP}$  is calculated using 方程式 34 and 方程式 35:

$$C_{COMP(over\ damping)} = \frac{\sqrt{[A_M \times A_{FB}]^2 - 1}}{2\pi \times R_O \times F_{CROSS}} = \frac{\sqrt{\left[ \frac{R_{LOAD}}{R_S \times 10} \times \frac{D'}{2} \times \frac{1.2}{V_{LOAD}} \times R_O \times Gm \right]^2 - 1}}{2\pi \times R_O \times F_{CROSS}} \quad (34)$$

$$C_{COMP(over\ damping)} = \frac{\sqrt{\left[ \frac{9.5}{7m \times 10} \times \frac{2.5}{9.5+0.7} \times \frac{1.2}{9.5} \times 10M \times 2m \right]^2 - 1}}{2\pi \times 10M \times 1.59k} = 162\text{ n[F]} \quad (35)$$

By selecting  $C_{COMP}$  following 方程式 34, the typical phase margin is set to 90° and the loop response is overdamped. In this example,  $F_{Z\_EA}$  is placed at a frequency 3 times higher than the  $F_{LP}$  to have lower phase margin but faster settling time ( $K2 = 3$ , target  $F_{Z\_EA}$  is 860 Hz). The recommended range of  $F_{Z\_EA}$  is from  $1 \times F_{LP}$  to  $4 \times F_{LP}$  ( $1 \leq K2 \leq 4$ ). Practical crossover frequency will vary with  $K2$  with a range of  $0.5 \times F_{CROSS}$  to  $1.0 \times F_{CROSS}$ .

$$C_{COMP} = \frac{C_{COMP(over\ damping)}}{K2} = \frac{162\text{ n}}{3} = 54\text{ n[F]} \quad (36)$$

A standard value of 56 nF is chosen for  $C_{COMP}$ .

$R_{COMP}$  is selected to set the error amplifier zero at 860 Hz.

$$R_{COMP} = \frac{1}{2\pi \times C_{COMP} \times F_{Z\_EA}} = \frac{1}{2\pi \times 56\text{ n} \times 860} = 3.31\text{ k}[\Omega] \quad (37)$$

A standard value of 3.32 kΩ is chosen for  $R_{COMP}$ .

$C_{HF}$  is usually used to create a pole at high frequency ( $F_{P\_EA}$ ) to cancel  $F_{Z\_ESR}$ . By using a small ESR capacitor that can place  $F_{Z\_ESR}$  greater than  $10 \times F_{CROSS}$ , the output capacitor ESR would not affect the loop stability. The maximum ESR which does not affect the loop response is calculated using 方程式 38.

$$R_{ESR(MAX)} = \frac{1}{2\pi \times C_{OUT} \times F_{CROSS} \times 10} = \frac{1}{2\pi \times 330\text{ u} \times 1.59\text{ k} \times 10} = 30\text{ m}[\Omega] \quad (38)$$

### 9.2.2.9 PVCC Capacitor, AVCC Capacitor, and AVCC Resistor

The PVCC capacitor supplies the peak transient current to the LO driver. The value of PVCC capacitor ( $C_{PVCC}$ ) must be 4.7 μF or higher and must be a high-quality, low-ESR, ceramic capacitor.  $C_{PVCC}$  must be placed close to the PVCC pin and the PGND pin. A value of 4.7 μF is selected for this design example. The AVCC capacitor must be placed close to the device. The recommended AVCC capacitor value is 0.1 μF. The AVCC resistor should be placed between PVCC and AVCC pins. The recommended AVCC resistor value is 10 Ω.

### 9.2.2.10 VOUT Filter ( $C_{VOUT}$ , $R_{VOUT}$ )

The VOUT pin is the input of the internal VCC regulator and also is the input of the output voltage sensing. To minimize noise at the VOUT pin, a 1-μF capacitor must be placed at the VOUT pin in most cases. If multiple

output capacitors are used, one of them can be placed at the VOUT pin as  $C_{VOUT}$ . The VOUT capacitor must be a high-quality, low-ESR, ceramic capacitor and must be placed close to the device. A resistor can be added at the VOUT pin ( $R_{VOUT}$ ) to form a RC filter (see [图 9-3](#)). In this case, the maximum resistor value should be less than or equal to  $2\ \Omega$ .

### 9.2.2.11 Input Capacitor

The input capacitors reduce the input voltage ripple. Assuming high-quality ceramic capacitors are used for the input capacitors, the maximum input voltage ripple can be calculated using [方程式 39](#).

$$V_{RIPPLY(CIN)} = \frac{V_{LOAD}}{32 \times L_M \times C_{IN} \times F_{SW}^2} [V] \quad (39)$$

The required input capacitor value is a function of the impedance of the source power supply. More input capacitors are required if the impedance of the source power supply is not low enough. In the example, three 10- $\mu$ F ceramic capacitors are used.

### 9.2.2.12 MOSFET Selection

The MOSFET gate driver of the LM51501-Q1 is powered by the internal 5-V VCC regulator. The MOSFET driven by the LM51501-Q1 must have a logic-level gate threshold with its on-resistance specified at 4.5 V or lower and must be rated to handle the maximum output voltage plus any switch node ringing. The maximum gate charge is limited by the 75-mA PVCC sourcing current limit, and is calculated in [方程式 40](#):

$$Q_{G(@5V)} < \frac{75m}{F_{SW}} [C] \quad (40)$$

A leadless package is preferred for high switching-frequency designs. The MOSFET gate capacitance should be small enough so that the gate voltage is fully discharged during the off-time.

### 9.2.2.13 Diode Selection

A Schottky is the preferred type for D1 diode due to its low forward voltage drop and small reverse recovery charge. Low reverse leakage current is an important parameter when selecting the Schottky diode. The diode must be rated to handle the maximum output voltage plus any switching node ringing. Also, it must be able to handle the average output current. To prevent chatter between wake-up and standby, the forward voltage drop of the D1 diode must be less than 0.95 V at full load.

### 9.2.2.14 Efficiency Estimation

The total loss of the boost converter ( $P_{TOTAL}$ ) can be expressed as the sum of the losses in the LM51501-Q1 ( $P_{IC}$ ), MOSFET power losses ( $P_Q$ ), diode power losses ( $P_D$ ), inductor power losses ( $P_L$ ), and the loss in the sense resistor ( $P_{RS}$ ).

$$P_{TOTAL} = P_{IC} + P_Q + P_D + P_L + P_{RS} [W] \quad (41)$$

$P_{IC}$  can be separated into gate driving loss ( $P_G$ ) and the losses caused by quiescent current ( $P_{IQ}$ ) in [方程式 42](#).

$$P_{IC} = P_G + P_{IQ} [W] \quad (42)$$

Each power loss is approximately calculated in [方程式 43](#) and [方程式 44](#):

$$P_G = Q_{G(@5V)} \times V_{VOUT} \times F_{SW} [W] \quad (43)$$

$$P_{IQ} = V_{VOUT} \times I_{VOUT} + V_{VIN} \times I_{VIN} [W] \quad (44)$$

$I_{VIN}$  and  $I_{VOUT}$  values in each mode can be found in the supply current section of [节 7.5](#).

$P_Q$  can be separated into switching loss ( $P_{Q(SW)}$ ) and conduction loss ( $P_{Q(COND)}$ ) in [方程式 45](#).

$$P_Q = P_{Q(SW)} + P_{Q(COND)} [W] \quad (45)$$

Each power loss is approximately calculated using [方程式 46](#):

$$P_{Q(SW)} = 0.5 \times (V_{VOUT} + V_F) \times I_{SUPPLY} \times (t_R + t_F) \times F_{SW} [W] \quad (46)$$

$t_R$  and  $t_F$  are the rise and fall times of the low-side N-channel MOSFET device.  $I_{SUPPLY}$  is the input supply current of the boost converter.

$$P_{Q(COND)} = D \times I_{SUPPLY}^2 \times R_{DS(ON)} [W] \quad (47)$$

$R_{DS(ON)}$  is the on-resistance of the MOSFET and is specified in the MOSFET data sheet. Consider the  $R_{DS(ON)}$  increase due to self-heating.

$P_D$  can be separated into diode conduction loss ( $P_{VF}$ ) and reverse recovery loss ( $P_{RR}$ ) in [方程式 48](#).

$$P_D = P_{VF} + P_{RR} [W] \quad (48)$$

Each power loss is approximately calculated using [方程式 49](#) and [方程式 50](#):

$$P_{VF} = (1 - D) \times V_F \times I_{SUPPLY} [W] \quad (49)$$

$$P_{RR} = V_{LOAD} \times Q_{RR} \times F_{SW} [W] \quad (50)$$

$Q_{RR}$  is the reverse recovery charge of the diode and is specified in the diode data sheet. Remember that reverse recovery characteristics of the diode strongly affect efficiency, especially when the output voltage is high.

$P_L$  is the sum of DCR loss ( $P_{DCR}$ ) and AC core loss ( $P_{AC}$ ) in [方程式 51](#). DCR is the DC resistance of inductor and is mentioned in the inductor data sheet.

$$P_L = P_{DCR} + P_{AC} [W] \quad (51)$$

Each power loss is approximately calculated by [方程式 52](#), [方程式 53](#), and [方程式 54](#):

$$P_{DCR} = I_{SUPPLY}^2 \times R_{DCR} [W] \quad (52)$$

$$P_{AC} = K \times \Delta I^\beta F_{SW}^\alpha [W] \quad (53)$$

where

- $\Delta I$  is the peak-to-peak inductor current ripple.
- $K$ ,  $\alpha$ , and  $\beta$  are core dependent factors that can be provided by the inductor manufacturer.

$$\Delta I = \frac{V_{SUPPLY} \times D \times \frac{1}{F_{SYNC}}}{L_M} \quad (54)$$

$P_{RS}$  is calculated as 方程式 55:

$$P_{RS} = D \times I_{SUPPLY}^2 \times R_S [W] \quad (55)$$

Efficiency of the power converter can be estimated using 方程式 56:

$$\text{Efficiency} = \frac{V_{LOAD} \times I_{LOAD}}{P_{TOTAL} + V_{LOAD} \times I_{LOAD}} \times 100[\%] \quad (56)$$

### 9.2.3 Application Curves



图 9-4. Automatic Wake-Up



图 9-5. Load Transient

### 9.3 System Examples

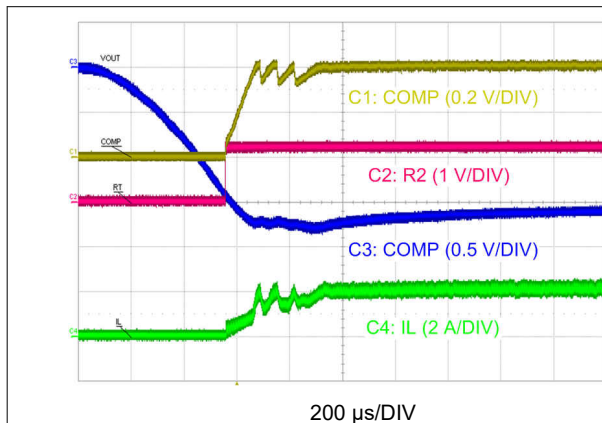
#### 9.3.1 Lower Standby Threshold in SS Configuration

By connecting the VIN pin to the VOUT pin, the current limit threshold at the current limit comparator input ( $V_{CL}$ ) is set to 1.2 V. In SS configuration, the VOUT standby threshold is ignored. The device goes into the standby mode when  $V_{OUT} > V_{IN}$  standby threshold.

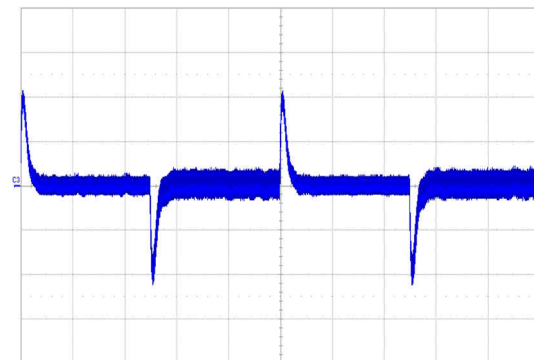

图 9-6. Lower Standby Threshold in SS Configuration

#### 9.3.2 Dithering Using Dither Enabled Device

Dithering is achieved by connecting DITH output to the RT pin through a resistor.

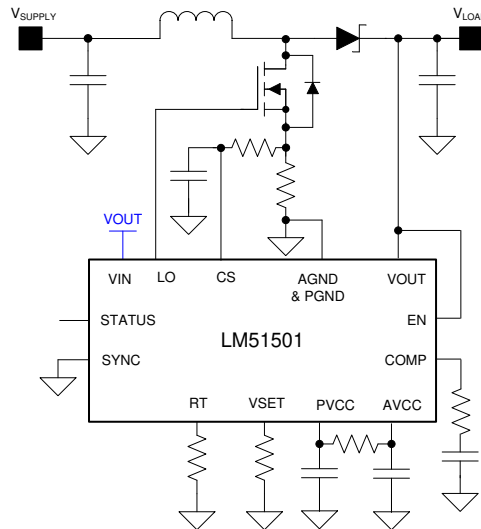

图 9-7. Dithering Using the Dither-Enabled Device LM5141

#### 9.3.3 Clock Synchronization With LM5140

Clock synchronization can be achieved by connecting LM5140's SYNCOUT to SYNC.

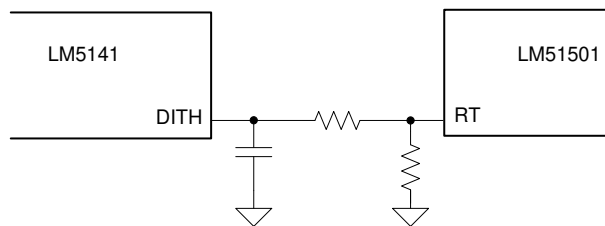

图 9-8. Clock Synchronization With LM5140

### 9.3.4 Dynamic Frequency Change

Switching frequency can be changed dynamically during operation by changing the RT resistor.

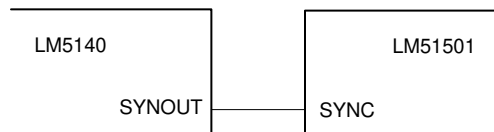

图 9-9. Dynamic Frequency Change

### 9.3.5 Dithering Using an External Clock

If a low-frequency clock is available, dithering can be achieved by injecting a ramp signal into RT.

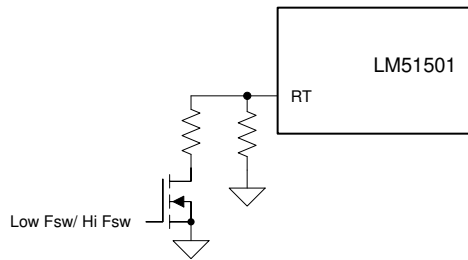

图 9-10. Dithering Using an External Clock

## 10 Power Supply Recommendations

The LM51501-Q1 is designed to operate from a power supply or battery with a voltage range of 1.5 V to 42 V. The input power supply should be able to supply the maximum boost supply voltage and handle the maximum input current at 1.5 V. The impedance of the power supply and battery, including cables, must be low enough that an input current transient does not cause an excessive drop. Additional input ceramic capacitors can be required at the supply input of the converter.

## 11 Layout

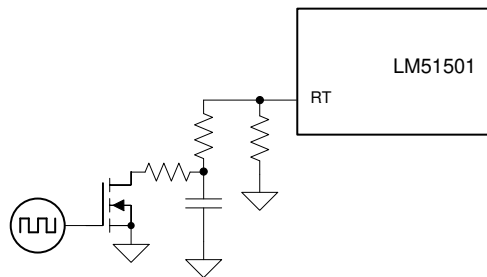
### 11.1 Layout Guidelines

The performance of switching converters heavily depends on the quality of the PCB layout. The following guidelines will help users design a PCB with the best power conversion performance, thermal performance, and minimize generation of unwanted EMI.

- Place Q1, D1, and  $R_S$  first.
- Place ceramic  $C_{OUT}$  and make the switching loop ( $C_{OUT}$ -D1-Q1- $R_S$ - $C_{OUT}$ ) as small as possible.
- Leave copper area next to D1 for thermal dissipation.
- Place LM51501-Q1 close to  $R_S$ .
- Place  $C_{PVCC}$  as close to the device as possible between PVCC and PGND.
- Connect PGND directly to the center of the sense resistor using a wide and short trace.
- Connect CS to the center of the sense resistor. Connect through vias if required. Connect filter capacitor between CS pin and exposed pad.
- Connect AGND directly to the analog ground plain and connect to  $R_{SET}$ ,  $R_T$ , and  $C_{COMP}$ .
- Connect the exposed pad to the analog ground plain and the power ground plain through vias.
- Connect LO directly to the gate of Q1.
- Make the switching signal loop (LO-Q1- $R_S$ -PGND-LO) as small as possible.
- Place  $C_{VOUT}$  as close to the device as possible.
- The LM51501-Q1 has an exposed thermal pad to aid power dissipation. Adding several vias under the exposed pad helps conduct heat away from the device. Connect the vias to a large ground plane on the bottom layer.

## 11.2 Layout Example



图 11-1. LM51501-Q1 PCB Layout Example

## 12 Device and Documentation Support

### 12.1 Device Support

#### 12.1.1 第三方产品免责声明

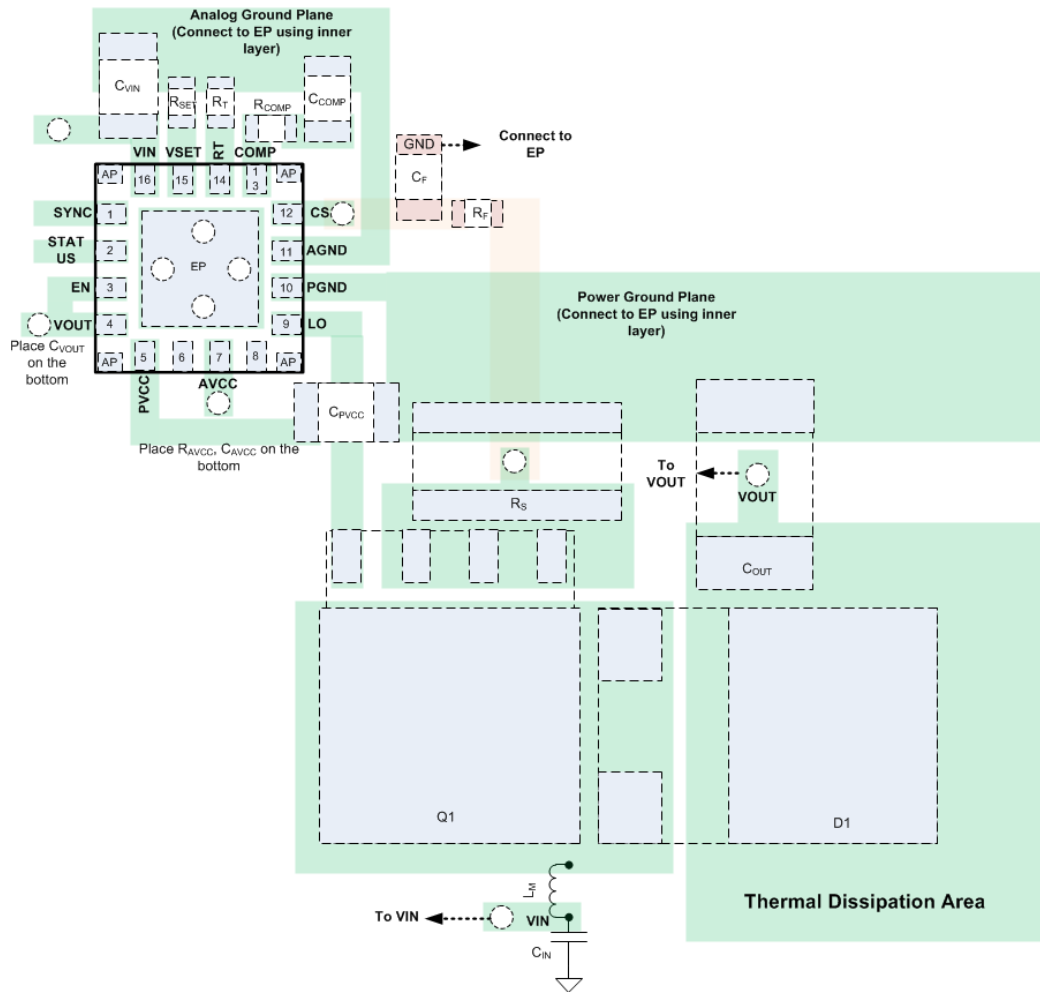
TI 发布的与第三方产品或服务有关的信息，不能构成与此类产品或服务或保修的适用性有关的认可，不能构成此类产品或服务单独或与任何 TI 产品或服务一起的表示或认可。

#### 12.1.2 Development Support

##### 12.1.2.1 Custom Design With WEBENCH® Tools

[Click here](#) to create a custom design using the LM51501-Q1 device with the WEBENCH® Power Designer.

1. Start by entering the input voltage ( $V_{IN}$ ), output voltage ( $V_{OUT}$ ), and output current ( $I_{OUT}$ ) requirements.
2. Optimize the design for key parameters such as efficiency, footprint, and cost using the optimizer dial.
3. Compare the generated design with other possible solutions from Texas Instruments.

The WEBENCH Power Designer provides a customized schematic along with a list of materials with real-time pricing and component availability.

In most cases, these actions are available:

- Run electrical simulations to see important waveforms and circuit performance
- Run thermal simulations to understand board thermal performance
- Export customized schematic and layout into popular CAD formats
- Print PDF reports for the design, and share the design with colleagues

Get more information about WEBENCH tools at [www.ti.com/WEBENCH](http://www.ti.com/WEBENCH).

### 12.2 接收文档更新通知

要接收文档更新通知，请导航至 [ti.com](http://ti.com) 上的器件产品文件夹。点击 [订阅更新](#) 进行注册，即可每周接收产品信息更改摘要。有关更改的详细信息，请查看任何已修订文档中包含的修订历史记录。

### 12.3 支持资源

**TI E2E™ 支持论坛** 是工程师的重要参考资料，可直接从专家获得快速、经过验证的解答和设计帮助。搜索现有解答或提出自己的问题可获得所需的快速设计帮助。

链接的内容由各个贡献者“按原样”提供。这些内容并不构成 TI 技术规范，并且不一定反映 TI 的观点；请参阅 TI 的《[使用条款](#)》。

### 12.4 Trademarks

TI E2E™ is a trademark of Texas Instruments.

WEBENCH® is a registered trademark of Texas Instruments.

is a registered trademark of Texas Instruments.

所有商标均为其各自所有者的财产。

### 12.5 Electrostatic Discharge Caution



This integrated circuit can be damaged by ESD. Texas Instruments recommends that all integrated circuits be handled with appropriate precautions. Failure to observe proper handling and installation procedures can cause damage.

ESD damage can range from subtle performance degradation to complete device failure. Precision integrated circuits may be more susceptible to damage because very small parametric changes could cause the device not to meet its published specifications.

### 12.6 术语表



#### TI 术语表

本术语表列出并解释了术语、首字母缩略词和定义。

## 13 Mechanical, Packaging, and Orderable Information

The following pages include mechanical, packaging, and orderable information. This information is the most current data available for the designated devices. This data is subject to change without notice and revision of this document. For browser-based versions of this data sheet, refer to the left-hand navigation.

**PACKAGING INFORMATION**

Orderable Device	Status (1)	Package Type	Package Drawing	Pins	Package Qty	Eco Plan (2)	Lead finish/ Ball material (6)	MSL Peak Temp (3)	Op Temp (°C)	Device Marking (4/5)	Samples
LM51501QRUMRQ1	ACTIVE	WQFN	RUM	16	2000	RoHS & Green	SN	Level-2-260C-1 YEAR	-40 to 125	LM 51501Q	
LM51501QRUMTQ1	ACTIVE	WQFN	RUM	16	250	RoHS & Green	SN	Level-2-260C-1 YEAR	-40 to 125	LM 51501Q	
LM51501QURUMRQ1	ACTIVE	WQFN	RUM	16	2000	RoHS & Green	SN	Level-2-260C-1 YEAR	-40 to 150	LM 51501QU	

(1) The marketing status values are defined as follows:

**ACTIVE:** Product device recommended for new designs.

**LIFEBUY:** TI has announced that the device will be discontinued, and a lifetime-buy period is in effect.

**NRND:** Not recommended for new designs. Device is in production to support existing customers, but TI does not recommend using this part in a new design.

**PREVIEW:** Device has been announced but is not in production. Samples may or may not be available.

**OBSELETE:** TI has discontinued the production of the device.

(2) **RoHS:** TI defines "RoHS" to mean semiconductor products that are compliant with the current EU RoHS requirements for all 10 RoHS substances, including the requirement that RoHS substance do not exceed 0.1% by weight in homogeneous materials. Where designed to be soldered at high temperatures, "RoHS" products are suitable for use in specified lead-free processes. TI may reference these types of products as "Pb-Free".

**RoHS Exempt:** TI defines "RoHS Exempt" to mean products that contain lead but are compliant with EU RoHS pursuant to a specific EU RoHS exemption.

**Green:** TI defines "Green" to mean the content of Chlorine (Cl) and Bromine (Br) based flame retardants meet JS709B low halogen requirements of <=1000ppm threshold. Antimony trioxide based flame retardants must also meet the <=1000ppm threshold requirement.

(3) MSL, Peak Temp. - The Moisture Sensitivity Level rating according to the JEDEC industry standard classifications, and peak solder temperature.

(4) There may be additional marking, which relates to the logo, the lot trace code information, or the environmental category on the device.

(5) Multiple Device Markings will be inside parentheses. Only one Device Marking contained in parentheses and separated by a "~" will appear on a device. If a line is indented then it is a continuation of the previous line and the two combined represent the entire Device Marking for that device.

(6) Lead finish/Ball material - Orderable Devices may have multiple material finish options. Finish options are separated by a vertical ruled line. Lead finish/Ball material values may wrap to two lines if the finish value exceeds the maximum column width.

**Important Information and Disclaimer:**The information provided on this page represents TI's knowledge and belief as of the date that it is provided. TI bases its knowledge and belief on information provided by third parties, and makes no representation or warranty as to the accuracy of such information. Efforts are underway to better integrate information from third parties. TI has taken and continues to take reasonable steps to provide representative and accurate information but may not have conducted destructive testing or chemical analysis on incoming materials and chemicals. TI and TI suppliers consider certain information to be proprietary, and thus CAS numbers and other limited information may not be available for release.

In no event shall TI's liability arising out of such information exceed the total purchase price of the TI part(s) at issue in this document sold by TI to Customer on an annual basis.

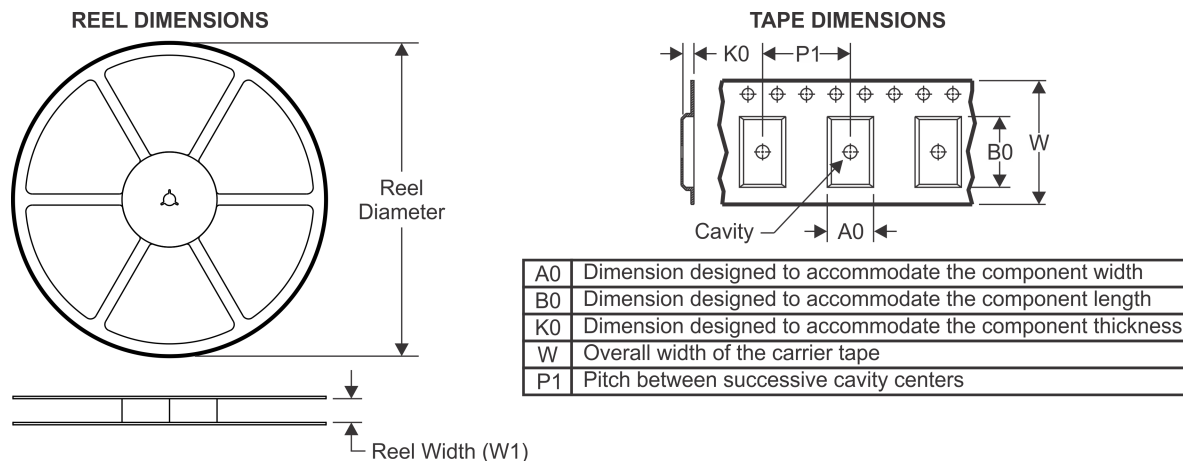
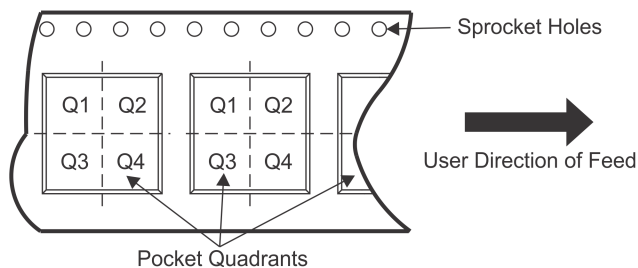
**TAPE AND REEL INFORMATION**

**QUADRANT ASSIGNMENTS FOR PIN 1 ORIENTATION IN TAPE**

\*All dimensions are nominal

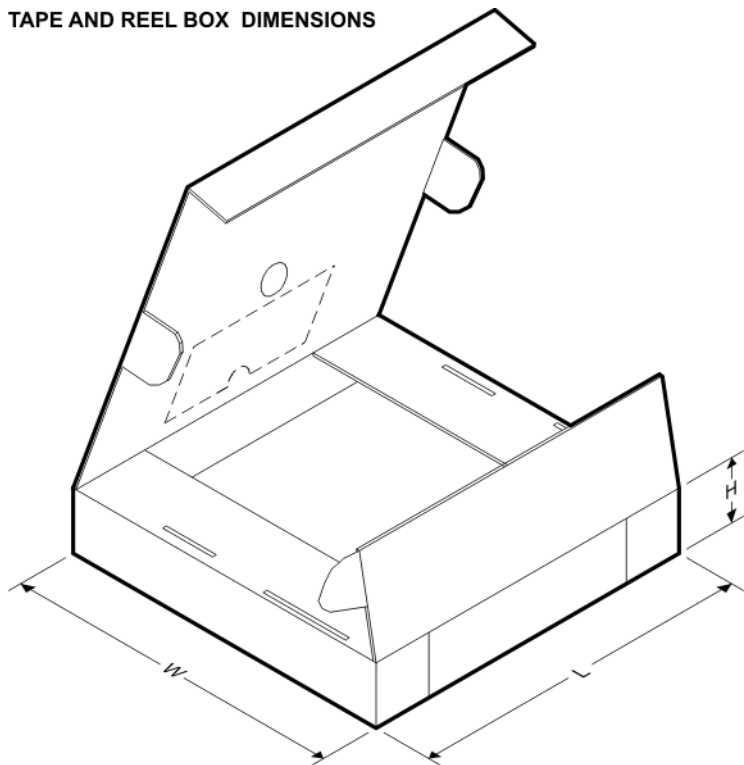
Device	Package Type	Package Drawing	Pins	SPQ	Reel Diameter (mm)	Reel Width W1 (mm)	A0 (mm)	B0 (mm)	K0 (mm)	P1 (mm)	W (mm)	Pin1 Quadrant
LM51501QRUMRQ1	WQFN	RUM	16	2000	330.0	12.4	4.3	4.3	1.1	8.0	12.0	Q1
LM51501QRUMTQ1	WQFN	RUM	16	250	180.0	12.4	4.3	4.3	1.1	8.0	12.0	Q1
LM51501QURUMRQ1	WQFN	RUM	16	2000	330.0	12.4	4.3	4.3	1.1	8.0	12.0	Q1

**TAPE AND REEL BOX DIMENSIONS**

\*All dimensions are nominal

Device	Package Type	Package Drawing	Pins	SPQ	Length (mm)	Width (mm)	Height (mm)
LM51501QRUMRQ1	WQFN	RUM	16	2000	367.0	367.0	38.0
LM51501QRUMTQ1	WQFN	RUM	16	250	213.0	191.0	35.0
LM51501QURUMRQ1	WQFN	RUM	16	2000	367.0	367.0	38.0

## 重要声明和免责声明

TI“按原样”提供技术和可靠性数据（包括数据表）、设计资源（包括参考设计）、应用或其他设计建议、网络工具、安全信息和其他资源，不保证没有瑕疵且不做任何明示或暗示的担保，包括但不限于对适销性、某特定用途方面的适用性或不侵犯任何第三方知识产权的暗示担保。

这些资源可供使用 TI 产品进行设计的熟练开发人员使用。您将自行承担以下全部责任：(1) 针对您的应用选择合适的 TI 产品，(2) 设计、验证并测试您的应用，(3) 确保您的应用满足相应标准以及任何其他功能安全、信息安全、监管或其他要求。

这些资源如有变更，恕不另行通知。TI 授权您仅可将这些资源用于研发本资源所述的 TI 产品的应用。严禁对这些资源进行其他复制或展示。您无权使用任何其他 TI 知识产权或任何第三方知识产权。您应全额赔偿因在这些资源的使用中对 TI 及其代表造成的任何索赔、损害、成本、损失和债务，TI 对此概不负责。

TI 提供的产品受 [TI 的销售条款](#) 或 [ti.com](#) 上其他适用条款/TI 产品随附的其他适用条款的约束。TI 提供这些资源并不会扩展或以其他方式更改 TI 针对 TI 产品发布的适用的担保或担保免责声明。

TI 反对并拒绝您可能提出的任何其他或不同的条款。

邮寄地址：Texas Instruments, Post Office Box 655303, Dallas, Texas 75265  
Copyright © 2021，德州仪器 (TI) 公司