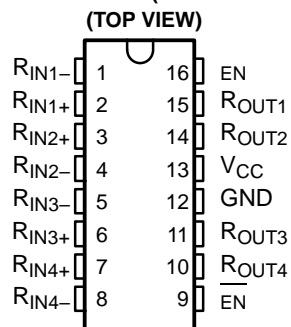


## LVDS QUAD DIFFERENTIAL LINE RECEIVER

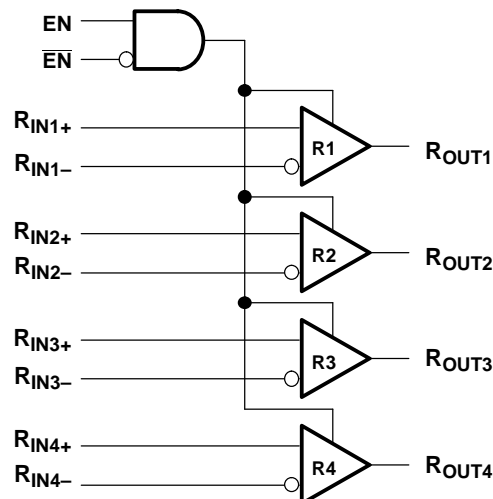
### FEATURES

- >400 Mbps (200 MHz) Signaling Rates
- Flow-Through Pinout Simplifies PCB Layout
- 50 ps Channel-to-Channel Skew (Typ)
- 200 ps Differential Skew (Typ)
- Propagation Delay Times 2.7 ns (Typ)
- 3.3-V Power Supply Design
- High Impedance LVDS Inputs on Power Down
- Low-Power Dissipation (40 mW at 3.3 V Static)
- Accepts Small Swing (350 mV) Differential Signal Levels
- Supports Open, Short, and Terminated Input Fail-Safe
- Industrial Operating Temperature Range (–40°C to 85°C)
- Conforms to TIA/EIA-644 LVDS Standard
- Available in SOIC and TSSOP Packages
- Pin-Compatible With DS90LV048A From National

SN65LVDS048AD (Marked as LVDS048A)  
SN65LVDS048APW (Marked as DL048A)



### functional diagram



### DESCRIPTION

The SN65LVDS048A is a quad differential line receiver that implements the electrical characteristics of low-voltage differential signaling (LVDS). This signaling technique lowers the output voltage levels of 5-V differential standard levels (such as EIA/TIA-422B) to reduce the power, increase the switching speeds, and allow operation with a 3.3-V supply rail. Any of the quad differential receivers will provide a valid logical output state with a  $\pm 100$ -mV differential input voltage within the input common-mode voltage range. The input common-mode voltage range allows 1 V of ground potential difference between two LVDS nodes

The intended application of this device and signaling technique is for point-to-point baseband data transmission over controlled impedance media of approximately 100  $\Omega$ . The transmission media may be printed-circuit board traces, backplanes, or cables. The ultimate rate and distance of data transfer is dependent upon the attenuation characteristics of the media, the noise coupling to the environment, and other system characteristics.

The SN65LVDS048A is characterized for operation from –40°C to 85°C.



Please be aware that an important notice concerning availability, standard warranty, and use in critical applications of Texas Instruments semiconductor products and disclaimers thereto appears at the end of this data sheet.



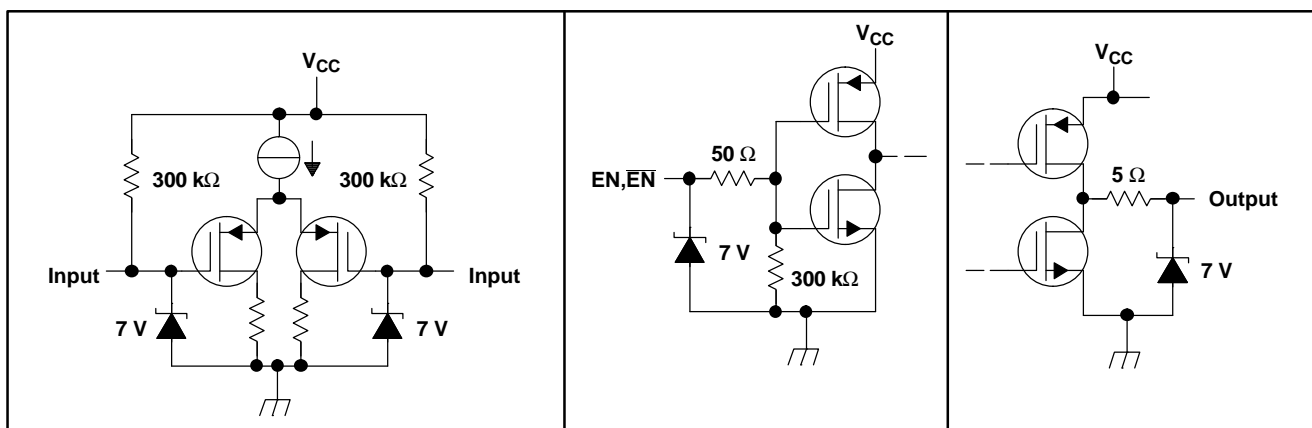
These devices have limited built-in ESD protection. The leads should be shorted together or the device placed in conductive foam during storage or handling to prevent electrostatic damage to the MOS gates.

**TRUTH TABLE<sup>(1)</sup>**

DIFFERENTIAL INPUT $R_{IN+} - R_{IN-}$	ENABLES		OUTPUT $R_{OUT}$
	EN	$\overline{EN}$	
$V_{ID} \geq 100 \text{ mV}$	H	L or OPEN	H
$V_{ID} \leq -100 \text{ mV}$			L
Open/short or terminated			H
X	All other conditions		Z

(1) H = high level, L = low level, X = irrelevant, Z = high impedance (off)

**EQUIVALENT INPUT AND OUTPUT SCHEMATIC DIAGRAMS**



**ABSOLUTE MAXIMUM RATINGS**

over operating free-air temperature range (unless otherwise noted)<sup>(1)(2)</sup>

		UNIT
$V_{CC}$	Supply voltage range	-0.3 V to 4 V
$V_I(R_{IN+}, R_{IN-})$	Input voltage range	-0.3 V to 4 V
	Enable input voltage (EN, $\overline{EN}$ )	-0.3 V to ( $V_{CC} + 0.3 \text{ V}$ )
$V_O(R_{OUT})$	Output voltage	-0.3 V to ( $V_{CC} + 0.3 \text{ V}$ )
	Bus-pin ( $R_{IN+}, R_{IN-}$ ) electrostatic discharge <sup>(3)</sup>	> 10 kV
	Continuous power dissipation	See Dissipation Rating Table
	Storage temperature range	-65°C to 150°C
	Lead temperature 1,6 mm (1/16 inch) from case for 10 seconds	260°C

- (1) Stresses beyond those listed under *absolute maximum ratings* may cause permanent damage to the device. These are stress ratings only, and functional operation of the device at these or any other conditions beyond those indicated under *recommended operating conditions* is not implied. Exposure to absolute-maximum-rated conditions for extended periods may affect device reliability.
- (2) All voltage values, except differential I/O bus voltages, are with respect to network ground terminal.
- (3) Tested in accordance with MIL-STD-883C Method 3015.7.

### DISSIPATION RATING TABLE

PACKAGE	$T_A \leq 25^\circ\text{C}$ POWER RATING	OPERATING FACTOR <sup>(1)</sup> ABOVE $T_A = 25^\circ\text{C}$	$T_A = 85^\circ\text{C}$ POWER RATING
D	950 mW	7.6 mW/°C	494 mW
PW	774 mW	6.2 mW/°C	402 mW

(1) This is the inverse of the junction-to-ambient thermal resistance when board-mounted and with no air flow.

### RECOMMENDED OPERATING CONDITIONS

	MIN	NOM	MAX	UNIT
$V_{CC}$ Supply voltage	3	3.3	3.6	V
Receiver input voltage	GND		3	V
$V_{IC}$ Common-mode input voltage	$\frac{ V_{ID} }{2}$		$2.4 - \frac{ V_{ID} }{2}$	V
			$V_{CC} - 0.8$	
$T_A$ Operating free-air temperature	-40	25	85	°C

### ELECTRICAL CHARACTERISTICS

over recommended operating free-air temperature range (unless otherwise noted)<sup>(1)</sup>

PARAMETER	TEST CONDITIONS	MIN	TYP <sup>(2)</sup>	MAX	UNIT	
$V_{IT+}$ Differential input high threshold voltage	$V_{CM} = 1.2\text{ V}, 0.05\text{ V}, 2.35\text{ V}^{(3)}$	100			mV	
$V_{IT-}$ Differential input low threshold voltage		-100				
$V_{(CMR)}$ Common mode voltage range	$V_{ID} = 200\text{ mV pk to pk}^{(4)}$	0.1		2.3	V	
$I_{IN}$ Input current	$V_{IN} = 2.8\text{ V}$	$V_{CC} = 3.6\text{ V or }0\text{ V}$	-20	$\pm 1$	20	$\mu\text{A}$
	$V_{IN} = 0\text{ V}$		-20	$\pm 1$	20	$\mu\text{A}$
	$V_{IN} = 3.6\text{ V},$		-20	$\pm 1$	20	$\mu\text{A}$
$V_{OH}$ Output high voltage	$I_{OH} = -0.4\text{ mA}, V_{ID} = 200\text{ mV}$	2.7	3.2		V	
	$I_{OH} = -0.4\text{ mA},$ input terminated	2.7	3.2		V	
	$I_{OH} = -0.4\text{ mA},$ input shorted	2.7	3.2		V	
$V_{OL}$ Output low voltage	$I_{OL} = 2\text{ mA}, V_{ID} = -200\text{ mV}$		0.05	0.25	V	
$I_{OS}$ Output short circuit current	Enabled, $V_{OUT} = 0\text{ V}^{(5)}$		-65	-100	mA	
$I_{O(Z)}$ Output 3-state current	Disabled, $V_{OUT} = 0\text{ V or }V_{CC}$	-1		1	$\mu\text{A}$	
$V_{IH}$ Input high voltage		2.0		$V_{CC}$	V	
$V_{IL}$ Input low voltage		GND		0.8	V	
$I_i$ Input current (enables)	$V_{IN} = 0\text{ V or }V_{CC},$ Other input = $V_{CC}$ or GND	-10		10	$\mu\text{A}$	
$V_{IK}$ Input clamp voltage	$I_{CL} = -18\text{ mA}$	-1.5	-0.8		V	
$I_{CC}$ No load supply current, receivers enabled	EN = $V_{CC}$ , Inputs open		8	15	mA	
$I_{CC(Z)}$ No load supply current, receivers disabled	EN = GND, Inputs open		0.6	1.5	mA	

- (1) Current into device pin is defined as positive. Current out of the device is defined as negative. All voltages are referenced to ground, unless otherwise specified.
- (2) All typical values are at 25°C and with a 3.3-V supply.
- (3)  $V_{CC}$  is always higher than  $R_{IN+}$  and  $R_{IN-}$  voltage,  $R_{IN-}$  and  $R_{IN+}$  have a voltage range of -0.2 V to  $V_{CC} - V_{ID}/2$ . To be compliant with ac specifications the common voltage range is 0.1 V to 2.3 V.
- (4) The VCMR range is reduced for larger  $V_{ID}$ . Example: If  $V_{ID} = 400\text{ mV}$ , the VCMR is 0.2 V to 2.2 V. The fail-safe condition with inputs shorted is not supported over the common-mode range of 0 V to 2.4 V, but is supported only with inputs shorted and no external common-mode voltage applied. A  $V_{ID}$  up to  $V_{CC} - 0\text{ V}$  may be applied to the  $R_{IN+}$  and  $R_{IN-}$  inputs with the common-mode voltage set to  $V_{CC}/2$ . Propagation delay and differential pulse skew decrease when  $V_{ID}$  is increased from 200 mV to 400 mV. Skew specifications apply for  $200\text{ mV} < V_{ID} < 800\text{ mV}$  over the common-mode range.
- (5) Output short circuit current ( $I_{OS}$ ) is specified as magnitude only, minus sign indicates direction only. Only one output should be shorted at a time. Do not exceed maximum junction temperature specification.

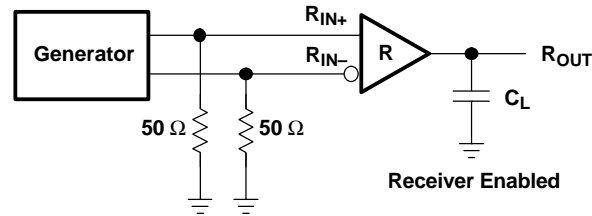
## SWITCHING CHARACTERISTICS

over recommended operating conditions (unless otherwise noted)<sup>(1)</sup>

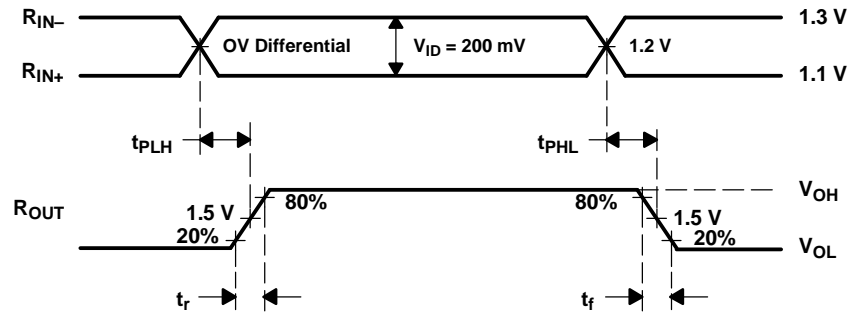
PARAMETER	TEST CONDITIONS	MIN	TYP <sup>(2)</sup>	MAX	UNIT	
$t_{PHL}$ Differential propagation delay, high-to-low	$C_L = 15\text{ pF}$ $V_{ID} = 200\text{ mV}$ (see Figure 1 and Figure 2)	1.9	2.7	3.7	ns	
$t_{PLH}$ Differential propagation delay, low-to-high		1.9	2.9	3.7	ns	
$t_{SK(p)}$ Differential pulse skew ( $t_{PHLD} - t_{PLHD}$ ) <sup>(3)</sup>			200	450	ps	
$t_{SK(o)}$ Differential channel-to-channel skew; same device <sup>(4)</sup>				50	500	ps
$t_{SK(pp)}$ Differential part-to-part skew <sup>(5)</sup>					1	ns
$t_{SK(lim)}$ Differential part-to-part skew <sup>(6)</sup>					1.5	ns
$t_r$ Rise time				0.5	1	ns
$t_f$ Fall time			0.5	1	ns	
$t_{PHZ}$ Disable time high to Z	$R_L = 2\text{ K } \Omega$ $C_L = 15\text{ pF}$ (see Figure 3 and Figure 4)		8	9	ns	
$t_{PLZ}$ Disable time low to Z			6	8	ns	
$t_{PZH}$ Enable time Z to high			8	10	ns	
$t_{PZL}$ Enable time Z to low			7	8	ns	
$f_{(MAX)}$ Maximum operating frequency <sup>(7)</sup>	All channels switching	200	250		MHz	

- (1) Generator waveform for all tests unless otherwise specified:  $f = 1\text{ MHz}$ ,  $Z_O = 50\text{ } \Omega$ ,  $t_r$  and  $t_f$  (0%–100%)  $\leq 3\text{ ns}$  for  $R_{IN}$ .
- (2) All typical values are at 25°C and with a 3.3-V supply.
- (3)  $t_{SK(p)} = |t_{PLH} - t_{PHL}|$  is the magnitude difference in differential propagation delay time between the positive going edge and the negative going edge of the same channel.
- (4)  $t_{SK(o)}$  is the differential channel-to-channel skew of any event on the same device.
- (5)  $t_{SK(pp)}$  is the differential part-to-part skew, and is defined as the difference between the minimum and the maximum specified differential propagation delays. This specification applies to devices at the same VCC and within 5°C of each other within the operating temperature range.
- (6)  $t_{SK(lim)}$  part-to-part skew, is the differential channel-to-channel skew of any event between devices. This specification applies to devices over recommended operating temperature and voltage ranges, and across process distribution.  $t_{sk(lim)}$  is defined as  $|Min - Max|$  differential propagation delay.
- (7)  $f_{(MAX)}$  generator input conditions:  $t_r = t_f < 1\text{ ns}$  (0% to 100%), 50% duty cycle, 0 V to 3 V. Output criteria: duty cycle = 45% to 55%,  $V_{OD} > 250\text{ mV}$ , all channels switching

**PARAMETER MEASUREMENT INFORMATION**

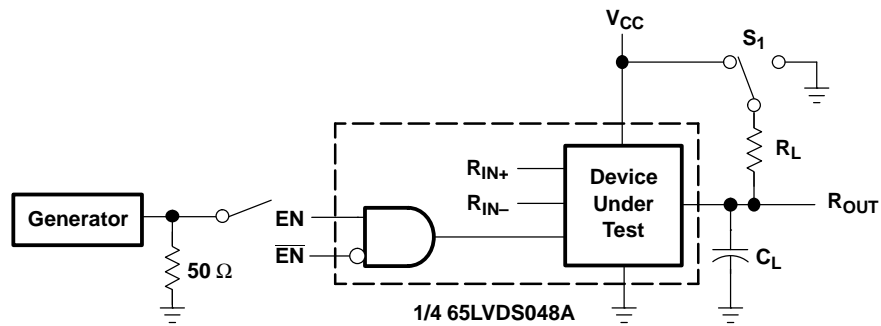


**Figure 1. Receiver Propagation Delay and Transition Time Test Circuit**



**Figure 2. Receiver Propagation Delay and Transition Time Waveforms**

PARAMETER MEASUREMENT INFORMATION (continued)



$C_L$  Includes Load and Test Jig Capacitance.  
 $S_1 = V_{CC}$  for  $t_{PZL}$  and  $t_{PLZ}$  Measurements.  
 $S_1 = GND$  for  $t_{PZH}$  and  $t_{PHZ}$  Measurements.

Figure 3. Receiver 3-State Delay Test Circuit

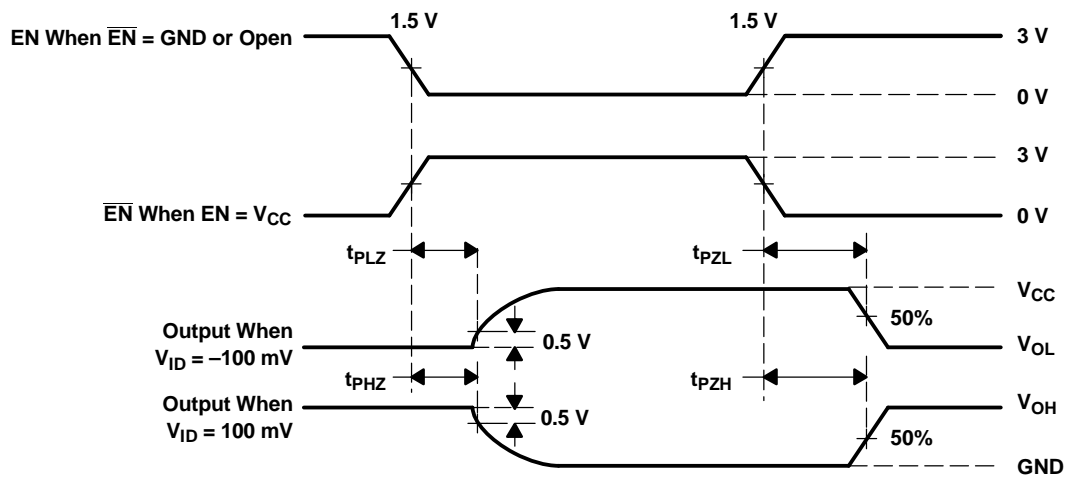


Figure 4. Receiver 3-State Delay Waveforms

**TYPICAL CHARACTERISTICS**

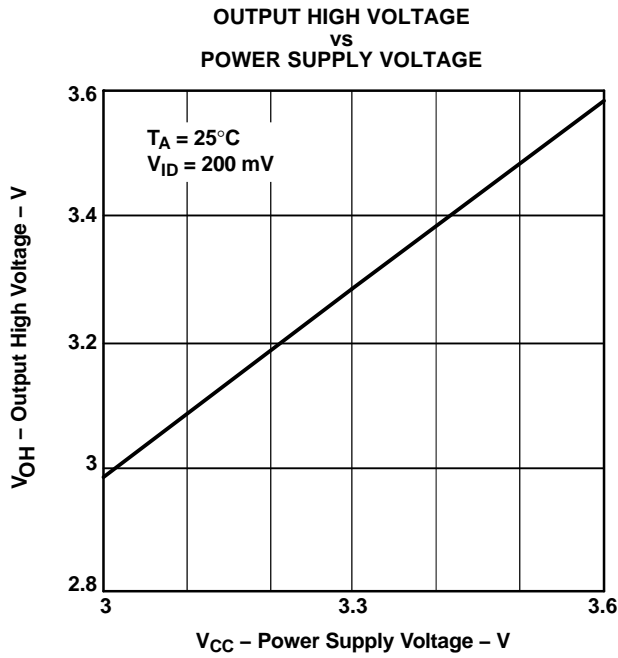


Figure 5.

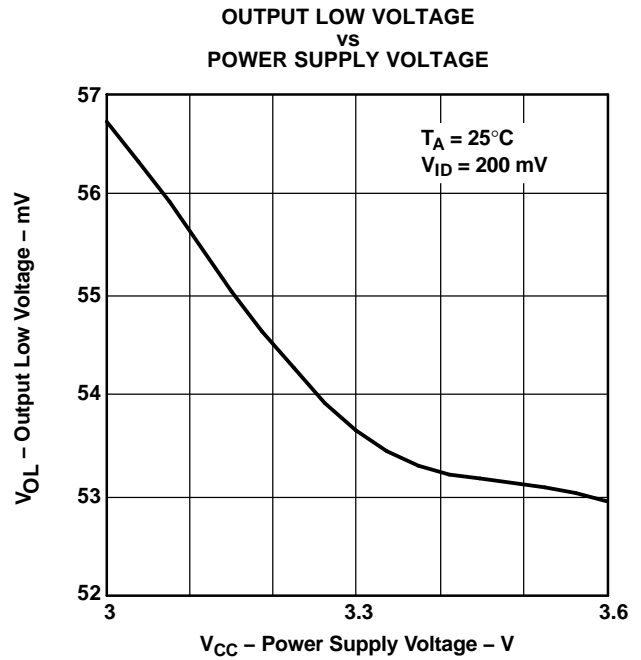


Figure 6.

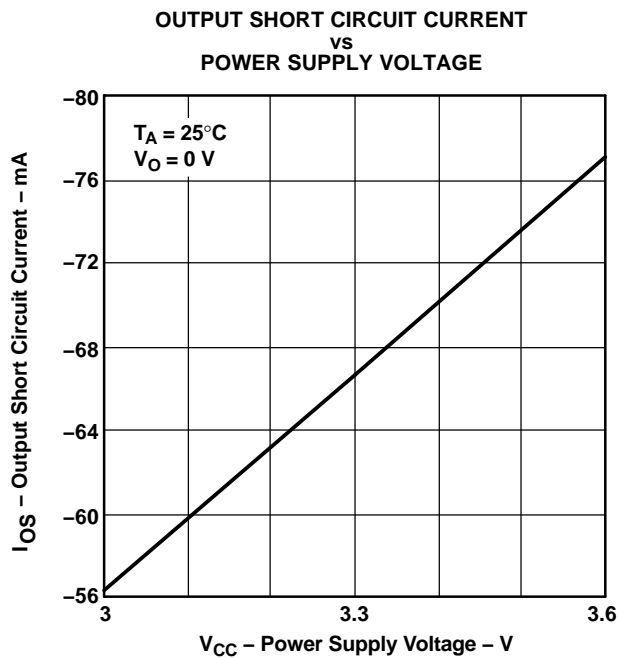
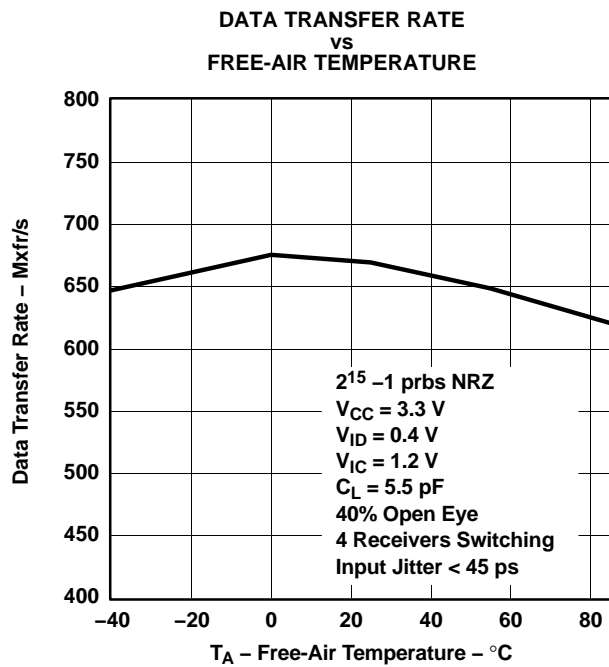
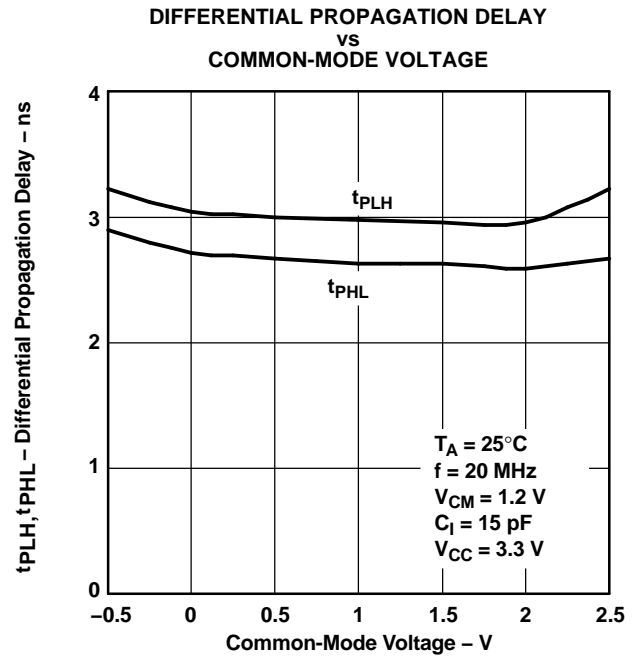
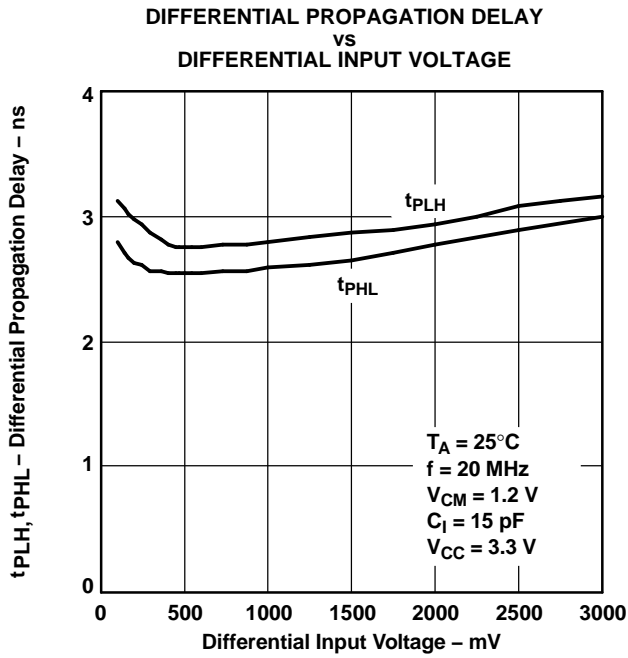


Figure 7.



Figure 8.

TYPICAL CHARACTERISTICS (continued)

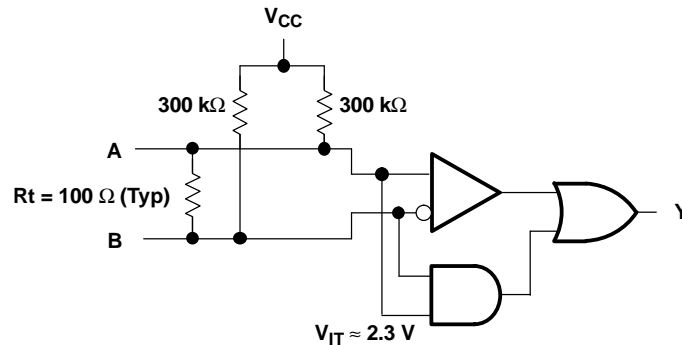


## APPLICATION INFORMATION

### FAIL SAFE

One of the most common problems with differential signaling applications is how the system responds when no differential voltage is present on the signal pair. The LVDS receiver is like most differential line receivers, in that its output logic state can be indeterminate when the differential input voltage is between  $-100\text{ mV}$  and  $100\text{ mV}$  and within its recommended input common-mode voltage range. TI's LVDS receiver is different in how it handles the open-input circuit situation, however.

Open-circuit means that there is little or no input current to the receiver from the data line itself. This could be when the driver is in a high-impedance state or the cable is disconnected. When this occurs, the LVDS receiver will pull each line of the signal pair to near  $V_{CC}$  through  $300\text{-k}\Omega$  resistors as shown in Figure 10. The fail-safe feature uses an AND gate with input voltage thresholds at about  $2.3\text{ V}$  to detect this condition and force the output to a high-level regardless of the differential input voltage.



**Figure 12. Open-Circuit Fail Safe of the LVDS Receiver**

It is only under these conditions that the output of the receiver will be valid with less than a  $100\text{-mV}$  differential input voltage magnitude. The presence of the termination resistor,  $R_t$ , does not affect the fail-safe function as long as it is connected as shown in the figure. Other termination circuits may allow a dc current to ground that could defeat the pullup currents from the receiver and the fail-safe feature.

**PACKAGING INFORMATION**

Orderable Device	Status (1)	Package Type	Package Drawing	Pins	Package Qty	Eco Plan (2)	Lead finish/ Ball material (6)	MSL Peak Temp (3)	Op Temp (°C)	Device Marking (4/5)	Samples
SN65LVDS048AD	ACTIVE	SOIC	D	16	40	RoHS & Green	NIPDAU	Level-1-260C-UNLIM	-40 to 85	LVDS048A	<a href="#">Samples</a>
SN65LVDS048ADG4	ACTIVE	SOIC	D	16	40	RoHS & Green	NIPDAU	Level-1-260C-UNLIM	-40 to 85	LVDS048A	<a href="#">Samples</a>
SN65LVDS048ADR	ACTIVE	SOIC	D	16	2500	RoHS & Green	NIPDAU	Level-1-260C-UNLIM	-40 to 85	LVDS048A	<a href="#">Samples</a>
SN65LVDS048ADRG4	ACTIVE	SOIC	D	16	2500	RoHS & Green	NIPDAU	Level-1-260C-UNLIM	-40 to 85	LVDS048A	<a href="#">Samples</a>
SN65LVDS048APW	ACTIVE	TSSOP	PW	16	90	RoHS & Green	NIPDAU	Level-1-260C-UNLIM	-40 to 85	DL048A	<a href="#">Samples</a>
SN65LVDS048APWG4	ACTIVE	TSSOP	PW	16	90	RoHS & Green	NIPDAU	Level-1-260C-UNLIM	-40 to 85	DL048A	<a href="#">Samples</a>
SN65LVDS048APWR	ACTIVE	TSSOP	PW	16	2000	RoHS & Green	NIPDAU	Level-1-260C-UNLIM	-40 to 85	DL048A	<a href="#">Samples</a>
SN65LVDS048APWRG4	ACTIVE	TSSOP	PW	16	2000	RoHS & Green	NIPDAU	Level-1-260C-UNLIM	-40 to 85	DL048A	<a href="#">Samples</a>

(1) The marketing status values are defined as follows:

**ACTIVE:** Product device recommended for new designs.

**LIFEBUY:** TI has announced that the device will be discontinued, and a lifetime-buy period is in effect.

**NRND:** Not recommended for new designs. Device is in production to support existing customers, but TI does not recommend using this part in a new design.

**PREVIEW:** Device has been announced but is not in production. Samples may or may not be available.

**OBSOLETE:** TI has discontinued the production of the device.

(2) **RoHS:** TI defines "RoHS" to mean semiconductor products that are compliant with the current EU RoHS requirements for all 10 RoHS substances, including the requirement that RoHS substance do not exceed 0.1% by weight in homogeneous materials. Where designed to be soldered at high temperatures, "RoHS" products are suitable for use in specified lead-free processes. TI may reference these types of products as "Pb-Free".

**RoHS Exempt:** TI defines "RoHS Exempt" to mean products that contain lead but are compliant with EU RoHS pursuant to a specific EU RoHS exemption.

**Green:** TI defines "Green" to mean the content of Chlorine (Cl) and Bromine (Br) based flame retardants meet JS709B low halogen requirements of <=1000ppm threshold. Antimony trioxide based flame retardants must also meet the <=1000ppm threshold requirement.

(3) MSL, Peak Temp. - The Moisture Sensitivity Level rating according to the JEDEC industry standard classifications, and peak solder temperature.

(4) There may be additional marking, which relates to the logo, the lot trace code information, or the environmental category on the device.

(5) Multiple Device Markings will be inside parentheses. Only one Device Marking contained in parentheses and separated by a "~" will appear on a device. If a line is indented then it is a continuation of the previous line and the two combined represent the entire Device Marking for that device.

<sup>(6)</sup> Lead finish/Ball material - Orderable Devices may have multiple material finish options. Finish options are separated by a vertical ruled line. Lead finish/Ball material values may wrap to two lines if the finish value exceeds the maximum column width.

**Important Information and Disclaimer:**The information provided on this page represents TI's knowledge and belief as of the date that it is provided. TI bases its knowledge and belief on information provided by third parties, and makes no representation or warranty as to the accuracy of such information. Efforts are underway to better integrate information from third parties. TI has taken and continues to take reasonable steps to provide representative and accurate information but may not have conducted destructive testing or chemical analysis on incoming materials and chemicals. TI and TI suppliers consider certain information to be proprietary, and thus CAS numbers and other limited information may not be available for release.

In no event shall TI's liability arising out of such information exceed the total purchase price of the TI part(s) at issue in this document sold by TI to Customer on an annual basis.

**TAPE AND REEL INFORMATION**

**QUADRANT ASSIGNMENTS FOR PIN 1 ORIENTATION IN TAPE**

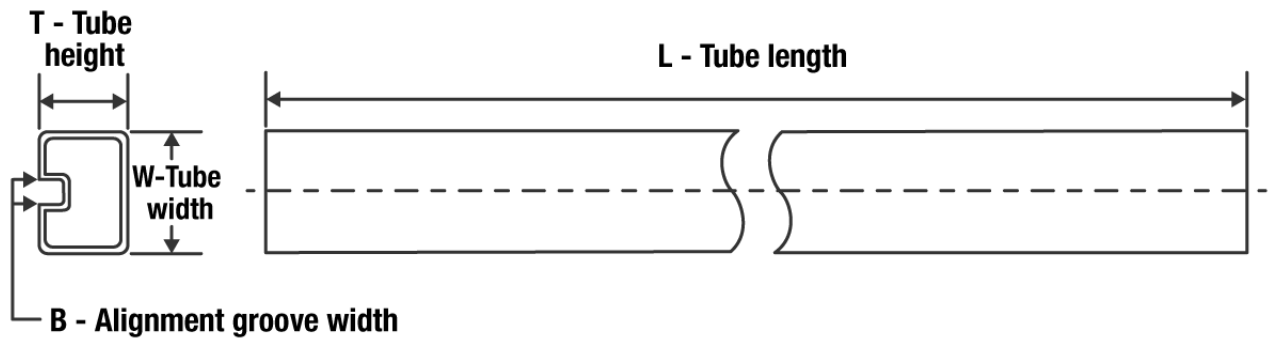

\*All dimensions are nominal

Device	Package Type	Package Drawing	Pins	SPQ	Reel Diameter (mm)	Reel Width W1 (mm)	A0 (mm)	B0 (mm)	K0 (mm)	P1 (mm)	W (mm)	Pin1 Quadrant
SN65LVDS048ADR	SOIC	D	16	2500	330.0	16.4	6.5	10.3	2.1	8.0	16.0	Q1
SN65LVDS048APWR	TSSOP	PW	16	2000	330.0	12.4	6.9	5.6	1.6	8.0	12.0	Q1

**TAPE AND REEL BOX DIMENSIONS**


\*All dimensions are nominal

Device	Package Type	Package Drawing	Pins	SPQ	Length (mm)	Width (mm)	Height (mm)
SN65LVDS048ADR	SOIC	D	16	2500	350.0	350.0	43.0
SN65LVDS048APWR	TSSOP	PW	16	2000	350.0	350.0	43.0

**TUBE**


\*All dimensions are nominal

Device	Package Name	Package Type	Pins	SPQ	L (mm)	W (mm)	T (μm)	B (mm)
SN65LVDS048AD	D	SOIC	16	40	505.46	6.76	3810	4
SN65LVDS048ADG4	D	SOIC	16	40	505.46	6.76	3810	4
SN65LVDS048APW	PW	TSSOP	16	90	530	10.2	3600	3.5
SN65LVDS048APWG4	PW	TSSOP	16	90	530	10.2	3600	3.5

## IMPORTANT NOTICE AND DISCLAIMER

TI PROVIDES TECHNICAL AND RELIABILITY DATA (INCLUDING DATA SHEETS), DESIGN RESOURCES (INCLUDING REFERENCE DESIGNS), APPLICATION OR OTHER DESIGN ADVICE, WEB TOOLS, SAFETY INFORMATION, AND OTHER RESOURCES "AS IS" AND WITH ALL FAULTS, AND DISCLAIMS ALL WARRANTIES, EXPRESS AND IMPLIED, INCLUDING WITHOUT LIMITATION ANY IMPLIED WARRANTIES OF MERCHANTABILITY, FITNESS FOR A PARTICULAR PURPOSE OR NON-INFRINGEMENT OF THIRD PARTY INTELLECTUAL PROPERTY RIGHTS.

These resources are intended for skilled developers designing with TI products. You are solely responsible for (1) selecting the appropriate TI products for your application, (2) designing, validating and testing your application, and (3) ensuring your application meets applicable standards, and any other safety, security, regulatory or other requirements.

These resources are subject to change without notice. TI grants you permission to use these resources only for development of an application that uses the TI products described in the resource. Other reproduction and display of these resources is prohibited. No license is granted to any other TI intellectual property right or to any third party intellectual property right. TI disclaims responsibility for, and you will fully indemnify TI and its representatives against, any claims, damages, costs, losses, and liabilities arising out of your use of these resources.

TI's products are provided subject to [TI's Terms of Sale](#) or other applicable terms available either on [ti.com](http://ti.com) or provided in conjunction with such TI products. TI's provision of these resources does not expand or otherwise alter TI's applicable warranties or warranty disclaimers for TI products.

TI objects to and rejects any additional or different terms you may have proposed.

Mailing Address: Texas Instruments, Post Office Box 655303, Dallas, Texas 75265  
Copyright © 2022, Texas Instruments Incorporated