

## SNx4HC244 Octal Buffers and Line Drivers With 3-State Outputs

### 1 Features

- Wide Operating Voltage Range of 2 V to 6 V
- High-Current Outputs Drive Up to 15 LSTTL Loads
- 3-State Outputs Drive Bus Lines or Buffer Memory Address Registers
- Low Power Consumption:  $I_{CC}$ , 80- $\mu$ A (Maximum)
- Typical  $t_{pd} = 11$  ns
- $\pm 6$ -mA Output Drive at 5 V
- Low Input Current of 1  $\mu$ A (Maximum)
- On Products Compliant to MIL-PRF-38535, All Parameters Are Tested Unless Otherwise Noted. On All Other Products, Production Processing Does Not Necessarily Include Testing of All Parameters.

### 2 Applications

- Servers
- LED Displays
- Network Switches
- Telecom Infrastructure
- Motor Drivers
- I/O Expanders

### 3 Description

The SNx4HC244 octal buffers and line drivers are designed specifically to improve both the performance and density of 3-state memory address drivers, clock drivers, and bus-oriented receivers and transmitters. The SNx4HC244 devices are organized as two 4-bit buffers and drivers with separate output-enable ( $\overline{OE}$ ) inputs. When  $\overline{OE}$  is low, the device passes noninverted data from the A inputs to the Y outputs. When  $\overline{OE}$  is high, the outputs are in the high-impedance state.

Device Information<sup>(1)</sup>

| PART NUMBER | PACKAGE (PINS) | BODY SIZE (NOM)    |
|-------------|----------------|--------------------|
| SN54HC244   | CDIP (20)      | 6.92 mm x 24.38 mm |
|             | CFP (20)       | 6.92 mm x 13.72 mm |
|             | LCCC (20)      | 8.89 mm x 8.89 mm  |
| SN74HC244DB | SSOP (20)      | 5.30 mm x 7.25 mm  |
| SN74HC244DW | SOIC (20)      | 7.50 mm x 12.80 mm |
| SN74HC244N  | PDIP (20)      | 6.30 mm x 25.40 mm |
| SN74HC244NS | SOP (20)       | 5.30 mm x 12.60 mm |
| SN74HC244PW | TSSOP (20)     | 4.40 mm x 6.50 mm  |

(1) For all available packages, see the orderable addendum at the end of the data sheet.

Logic Diagram (Positive Logic)

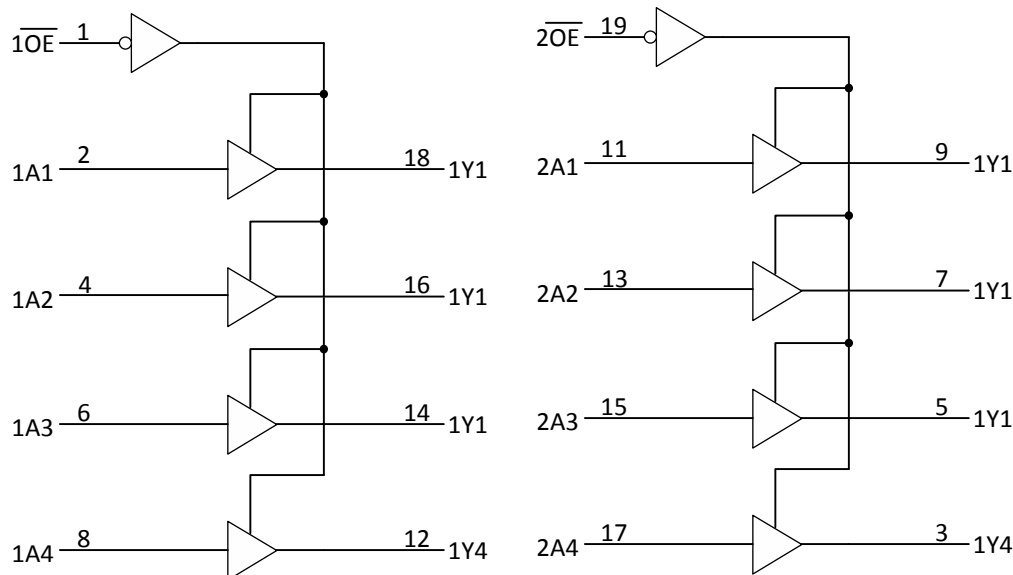

Copyright © 2016, Texas Instruments Incorporated



## Table of Contents

|   |           |  |           |
|---|-----------|--|-----------|
| <b>1 Features</b> .....                               | <b>1</b>  | 8.1 Overview .....   | <b>11</b> |
| <b>2 Applications</b> .....                           | <b>1</b>  | 8.2 Functional Block Diagram .....                               | <b>11</b> |
| <b>3 Description</b> .....                            | <b>1</b>  | 8.3 Feature Description .....                                    | <b>11</b> |
| <b>4 Revision History</b> .....                       | <b>2</b>  | 8.4 Device Functional Modes .....                                | <b>11</b> |
| <b>5 Pin Configuration and Functions</b> .....        | <b>3</b>  | <b>9 Application and Implementation</b> .....                    | <b>12</b> |
| <b>6 Specifications</b> .....                         | <b>4</b>  | 9.1 Application Information .....                                | <b>12</b> |
| 6.1 Absolute Maximum Ratings .....                    | <b>4</b>  | 9.2 Typical Application .....                                    | <b>12</b> |
| 6.2 ESD Ratings .....                                 | <b>4</b>  | <b>10 Power Supply Recommendations</b> .....                     | <b>13</b> |
| 6.3 Recommended Operating Conditions .....            | <b>4</b>  | <b>11 Layout</b> .....   | <b>13</b> |
| 6.4 Thermal Information .....                         | <b>5</b>  | 11.1 Layout Guidelines .....                                     | <b>13</b> |
| 6.5 Electrical Characteristics .....                  | <b>5</b>  | 11.2 Layout Example .....  | <b>13</b> |
| 6.6 Electrical Characteristics – SN54HC244 .....      | <b>5</b>  | <b>12 Device and Documentation Support</b> .....                 | <b>14</b> |
| 6.7 Electrical Characteristics – SN74HC244 .....      | <b>6</b>  | 12.1 Related Links .....   | <b>14</b> |
| 6.8 Switching Characteristics .....                   | <b>6</b>  | 12.2 Community Resources .....                                   | <b>14</b> |
| 6.9 Switching Characteristics – $C_L = 50$ pF .....   | <b>7</b>  | 12.3 Trademarks .....  | <b>14</b> |
| 6.10 Switching Characteristics – $C_L = 150$ pF ..... | <b>7</b>  | 12.4 Electrostatic Discharge Caution .....                       | <b>14</b> |
| 6.11 Typical Characteristic .....                     | <b>8</b>  | 12.5 Glossary .....  | <b>14</b> |
| <b>7 Parameter Measurement Information</b> .....      | <b>9</b>  | <b>13 Mechanical, Packaging, and Orderable Information</b> ..... | <b>14</b> |
| <b>8 Detailed Description</b> .....                   | <b>11</b> |  |           |

## 4 Revision History

NOTE: Page numbers for previous revisions may differ from page numbers in the current version.

| <b>Changes from Revision D (August 2003) to Revision E</b>   | <b>Page</b> |
|--|-------------|
| • Added <i>ESD Ratings</i> table, <i>Feature Description</i> section, <i>Device Functional Modes</i> , <i>Application and Implementation</i> section, <i>Power Supply Recommendations</i> section, <i>Layout</i> section, <i>Device and Documentation Support</i> section, and <i>Mechanical, Packaging, and Orderable Information</i> section ..... | <b>1</b>    |
| • Added Military Disclaimer to <i>Features</i> section .....   | <b>1</b>    |
| • Added <i>Applications</i> section .....  | <b>1</b>    |
| • Removed Ordering Information table .....   | <b>1</b>    |
| • Added <i>Device Information</i> table .....  | <b>1</b>    |

## 5 Pin Configuration and Functions

DB, DW, J, N, NS, PW, W Package  
20-Pin SSOP, SOIC, CDIP, PDIP, SOP, TSSOP, or CFP  
Top View

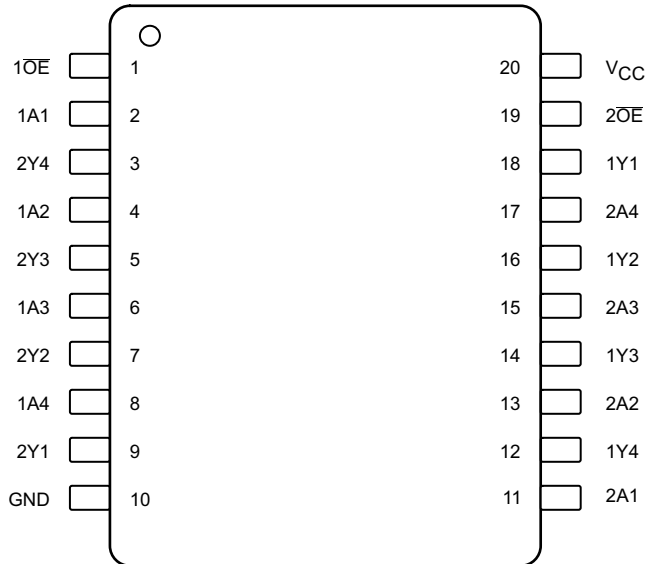

FK Package  
20-Pin LCCC  
Top View

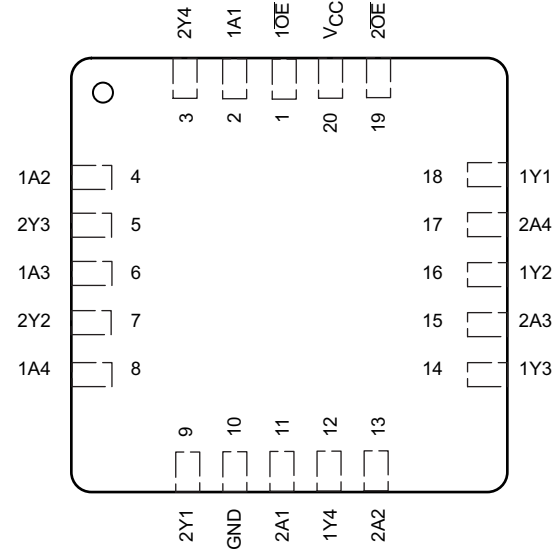

### Pin Functions

| PIN |                   | I/O | DESCRIPTION   |
|-----|-------------------|-----|---------------|
| NO. | NAME              |     |               |
| 1   | 1 $\overline{OE}$ | I   | Output Enable |
| 2   | 1A1               | I   | Input         |
| 3   | 2Y4               | O   | Output        |
| 4   | 1A2               | I   | Input         |
| 5   | 2Y3               | O   | Output        |
| 6   | 1A3               | I   | Input         |
| 7   | 2Y2               | O   | Output        |
| 8   | 1A4               | I   | Input         |
| 9   | 2Y1               | O   | Output        |
| 10  | GND               | —   | Ground        |
| 11  | 2A1               | I   | Input         |
| 12  | 1Y4               | O   | Output        |
| 13  | 2A2               | I   | Input         |
| 14  | 1Y3               | O   | Output        |
| 15  | 2A3               | I   | Input         |
| 16  | 1Y2               | O   | Output        |
| 17  | 2A4               | I   | Input         |
| 18  | 1Y1               | O   | Output        |
| 19  | 2 $\overline{OE}$ | I   | Output Enable |
| 20  | V <sub>CC</sub>   | —   | Power Pin     |

## 6 Specifications

### 6.1 Absolute Maximum Ratings

 over operating free-air temperature range (unless otherwise noted)<sup>(1)</sup>

|  |  | MIN  | MAX | UNIT |
|--|--|------|-----|------|
| Supply voltage range, $V_{CC}$             |  | -0.5 | 7   | V    |
| Input clamp current, $I_{IK}$              | $V_I < 0$ or $V_I > V_{CC}$ <sup>(2)</sup> |      | ±20 | mA   |
| Output clamp current, $I_{OK}$             | $V_O < 0$ or $V_O > V_{CC}$ <sup>(2)</sup> |      | ±20 | mA   |
| Continuous output current, $I_O$           | $V_O = 0$ or $V_{CC}$                      |      | ±35 | mA   |
| Continuous current through $V_{CC}$ or GND |  |      | ±70 | mA   |
| Junction Temperature, $T_J$                |  |      | 150 | °C   |
| Storage temperature, $T_{stg}$             |  | -65  | 150 | °C   |

- (1) Stresses beyond those listed under *Absolute Maximum Ratings* may cause permanent damage to the device. These are stress ratings only, which do not imply functional operation of the device at these or any other conditions beyond those indicated under *Recommended Operating Conditions*. Exposure to absolute-maximum-rated conditions for extended periods may affect device reliability.
- (2) The input and output voltage ratings may be exceeded if the input and output current ratings are observed.

### 6.2 ESD Ratings

|             |                         | SN74HC244  | VALUE | UNIT |
|-------------|-------------------------|--|-------|------|
| $V_{(ESD)}$ | Electrostatic discharge | Human-body model (HBM), per ANSI/ESDA/JEDEC JS-001 <sup>(1)</sup>              | ±2000 | V    |
|             |                         | Charged-device model (CDM), per JEDEC specification JESD22-C101 <sup>(2)</sup> | ±1000 |      |

- (1) JEDEC document JEP155 states that 500-V HBM allows safe manufacturing with a standard ESD control process.
- (2) JEDEC document JEP157 states that 250-V CDM allows safe manufacturing with a standard ESD control process.

### 6.3 Recommended Operating Conditions

 over operating free-air temperature range (unless otherwise noted)<sup>(1)</sup>

|                     |  | MIN              | NOM  | MAX      | UNIT |
|---------------------|--|------------------|------|----------|------|
| $V_{CC}$            | Supply voltage   | 2                | 5    | 6        | V    |
| $V_{IH}$            | High-level input voltage                                     | $V_{CC} = 2$ V   | 1.5  |          | V    |
|                     |  | $V_{CC} = 4.5$ V | 3.15 |          |      |
|                     |  | $V_{CC} = 6$ V   | 4.2  |          |      |
| $V_{IL}$            | Low-level input voltage                                      | $V_{CC} = 2$ V   |      | 0.5      | V    |
|                     |  | $V_{CC} = 4.5$ V |      | 1.35     |      |
|                     |  | $V_{CC} = 6$ V   |      | 1.8      |      |
| $V_I$               | Input voltage  | 0                |      | $V_{CC}$ | V    |
| $V_O$               | Output voltage   | 0                |      | $V_{CC}$ | V    |
| $\Delta t/\Delta v$ | Input transition rise and fall time                          | $V_{CC} = 2$ V   |      | 1000     | ns/V |
|                     |  | $V_{CC} = 4.5$ V |      | 500      |      |
|                     |  | $V_{CC} = 6$ V   |      | 400      |      |
| $C_{pd}$            | Power dissipation capacitance per buffer or driver (no load) |                  | 35   |          | pF   |
| $T_A$               | Operating free-air temperature                               | SN54HC244        | -55  | 125      | °C   |
|                     |  | SN74HC244        | -40  | 85       |      |

- (1) All unused inputs of the device must be held at  $V_{CC}$  or GND to ensure proper device operation. See the Texas Instruments application report, *Implications of Slow or Floating CMOS Inputs*, [SCBA004](#).

## 6.4 Thermal Information

| THERMAL METRIC <sup>(1)</sup> | SN54HC244, SN74HC244                         |           |          |          |            | UNIT |      |
|-------------------------------|--|-----------|----------|----------|------------|------|------|
|                               | DB (SSOP)                                    | DW (SOIC) | N (PDIP) | NS (SOP) | PW (TSSOP) |      |      |
|                               | 20 PINS                                      | 20 PINS   | 20 PINS  | 20 PINS  | 20 PINS    |      |      |
| R <sub>θJA</sub>              | Junction-to-ambient thermal resistance       | 89.5      | 76.8     | 44.9     | 71.9       | 97.5 | °C/W |
| R <sub>θJC(top)</sub>         | Junction-to-case (top) thermal resistance    | 50.9      | 42.2     | 30.9     | 38.2       | 32.6 | °C/W |
| R <sub>θJB</sub>              | Junction-to-board thermal resistance         | 44.6      | 44.6     | 25.8     | 39.3       | 48.4 | °C/W |
| ψ <sub>JT</sub>               | Junction-to-top characterization parameter   | 17        | 15.6     | 16.4     | 14.9       | 1.7  | °C/W |
| ψ <sub>JB</sub>               | Junction-to-board characterization parameter | 44.2      | 44.1     | 25.7     | 39         | 47.9 | °C/W |

(1) For more information about traditional and new thermal metrics, see the *Semiconductor and IC Package Thermal Metrics* application report, [SPRA953](#).

## 6.5 Electrical Characteristics

T<sub>A</sub> = 25°C (unless otherwise noted)

| PARAMETER       | TEST CONDITIONS  |  | MIN                     | TYP   | MAX   | UNIT |
|-----------------|--|--|-------------------------|-------|-------|------|
| V <sub>OH</sub> | V <sub>I</sub> = V <sub>IH</sub> or V <sub>IL</sub>  | I <sub>OH</sub> = -20 μA                         | V <sub>CC</sub> = 2 V   | 1.9   | 1.998 | V    |
|                 |  |  | V <sub>CC</sub> = 4.5 V | 4.4   | 4.499 |      |
|                 |  |  | V <sub>CC</sub> = 6 V   | 5.9   | 5.999 |      |
|                 |  | I <sub>OH</sub> = -6 mA, V <sub>CC</sub> = 4.5 V | 3.98                    | 4.3   |       |      |
|                 |  | I <sub>OH</sub> = -7.8 mA, V <sub>CC</sub> = 6 V | 5.48                    | 5.8   |       |      |
| V <sub>OL</sub> | V <sub>I</sub> = V <sub>IH</sub> or V <sub>IL</sub>  | I <sub>OL</sub> = 20 μA                          | V <sub>CC</sub> = 2 V   | 0.002 | 0.1   | V    |
|                 |  |  | V <sub>CC</sub> = 4.5 V | 0.001 | 0.1   |      |
|                 |  |  | V <sub>CC</sub> = 6 V   | 0.001 | 0.1   |      |
|                 |  | I <sub>OL</sub> = 6 mA, V <sub>CC</sub> = 4.5 V  | 0.17                    | 0.26  |       |      |
|                 |  | I <sub>OL</sub> = 7.8 mA, V <sub>CC</sub> = 6 V  | 0.15                    | 0.26  |       |      |
| I <sub>I</sub>  | V <sub>I</sub> = V <sub>CC</sub> or 0, V <sub>CC</sub> = 6 V   |  | ±0.1                    | ±100  | nA    |      |
| I <sub>OZ</sub> | V <sub>O</sub> = V <sub>CC</sub> or 0, V <sub>I</sub> = V <sub>IH</sub> or V <sub>IL</sub> , V <sub>CC</sub> = 6 V |  | ±0.01                   | ±0.5  | μA    |      |
| I <sub>CC</sub> | V <sub>I</sub> = V <sub>CC</sub> or 0, I <sub>O</sub> = 0, V <sub>CC</sub> = 6 V                                   |  |                         | 8     | μA    |      |
| C <sub>i</sub>  | V <sub>CC</sub> = 2 V to 6 V   |  |                         | 3     | 10    | pF   |

## 6.6 Electrical Characteristics – SN54HC244

over recommended operating free-air temperature range (unless otherwise noted)

| PARAMETER       | TEST CONDITIONS  |  | MIN                     | TYP   | MAX | UNIT |
|-----------------|--|--|-------------------------|-------|-----|------|
| V <sub>OH</sub> | V <sub>I</sub> = V <sub>IH</sub> or V <sub>IL</sub>  | I <sub>OH</sub> = -20 μA                         | V <sub>CC</sub> = 2 V   | 1.9   |     | V    |
|                 |  |  | V <sub>CC</sub> = 4.5 V | 4.4   |     |      |
|                 |  |  | V <sub>CC</sub> = 6 V   | 5.9   |     |      |
|                 |  | I <sub>OH</sub> = -6 mA, V <sub>CC</sub> = 4.5 V | 3.7                     |       |     |      |
|                 |  | I <sub>OH</sub> = -7.8 mA, V <sub>CC</sub> = 6 V | 5.2                     |       |     |      |
| V <sub>OL</sub> | V <sub>I</sub> = V <sub>IH</sub> or V <sub>IL</sub>  | I <sub>OL</sub> = 20 μA                          | V <sub>CC</sub> = 2 V   |       | 0.1 | V    |
|                 |  |  | V <sub>CC</sub> = 4.5 V |       | 0.1 |      |
|                 |  |  | V <sub>CC</sub> = 6 V   |       | 0.1 |      |
|                 |  | I <sub>OL</sub> = 6 mA, V <sub>CC</sub> = 4.5 V  |                         | 0.4   |     |      |
|                 |  | I <sub>OL</sub> = 7.8 mA, V <sub>CC</sub> = 6 V  |                         | 0.4   |     |      |
| I <sub>I</sub>  | V <sub>I</sub> = V <sub>CC</sub> or 0, V <sub>CC</sub> = 6 V   |  |                         | ±1000 | nA  |      |
| I <sub>OZ</sub> | V <sub>O</sub> = V <sub>CC</sub> or 0, V <sub>I</sub> = V <sub>IH</sub> or V <sub>IL</sub> , V <sub>CC</sub> = 6 V |  |                         | ±10   | μA  |      |
| I <sub>CC</sub> | V <sub>I</sub> = V <sub>CC</sub> or 0, I <sub>O</sub> = 0, V <sub>CC</sub> = 6 V                                   |  |                         | 160   | μA  |      |
| C <sub>i</sub>  | V <sub>CC</sub> = 2 V to 6 V   |  |                         | 10    | pF  |      |

## 6.7 Electrical Characteristics – SN74HC244

over recommended operating free-air temperature range (unless otherwise noted)

| PARAMETER | TEST CONDITIONS  |                                  | MIN              | TYP  | MAX        | UNIT    |
|-----------|--|----------------------------------|------------------|------|------------|---------|
| $V_{OH}$  | $V_I = V_{IH}$ or $V_{IL}$                                       | $I_{OH} = -20 \mu A$             | $V_{CC} = 2 V$   | 1.9  |            | V       |
|           |  |                                  | $V_{CC} = 4.5 V$ | 4.4  |            |         |
|           |  |                                  | $V_{CC} = 6 V$   | 5.9  |            |         |
|           |  | $I_{OH} = -6 mA, V_{CC} = 4.5 V$ | 3.84             |      |            |         |
|           |  | $I_{OH} = -7.8 mA, V_{CC} = 6 V$ | 5.34             |      |            |         |
| $V_{OL}$  | $V_I = V_{IH}$ or $V_{IL}$                                       | $I_{OL} = 20 \mu A$              | $V_{CC} = 2 V$   |      | 0.1        | V       |
|           |  |                                  | $V_{CC} = 4.5 V$ |      | 0.1        |         |
|           |  |                                  | $V_{CC} = 6 V$   |      | 0.1        |         |
|           |  | $I_{OL} = 6 mA, V_{CC} = 4.5 V$  |                  | 0.33 |            |         |
|           |  | $I_{OL} = 7.8 mA, V_{CC} = 6 V$  |                  | 0.33 |            |         |
| $I_I$     | $V_I = V_{CC}$ or 0, $V_{CC} = 6 V$                              |                                  |                  |      | $\pm 1000$ | nA      |
| $I_{OZ}$  | $V_O = V_{CC}$ or 0, $V_I = V_{IH}$ or $V_{IL}$ , $V_{CC} = 6 V$ |                                  |                  |      | $\pm 5$    | $\mu A$ |
| $I_{CC}$  | $V_I = V_{CC}$ or 0, $I_O = 0$ , $V_{CC} = 6 V$                  |                                  |                  |      | 80         | $\mu A$ |
| $C_i$     | $V_{CC} = 2 V$ to $6 V$  |                                  |                  |      | 10         | pF      |

## 6.8 Switching Characteristics

 $T_A = 25^\circ C$  (unless otherwise noted; see [Figure 2](#))

| PARAMETER | TEST CONDITIONS                            |                  | MIN            | TYP | MAX | UNIT |
|-----------|--|------------------|----------------|-----|-----|------|
| $t_{pd}$  | From A (input) to Y (output)               | $V_{CC} = 2 V$   | $C_L = 50 pF$  | 40  | 115 | ns   |
|           |  |                  | $C_L = 150 pF$ | 56  | 165 |      |
|           |  | $V_{CC} = 4.5 V$ | $C_L = 50 pF$  | 13  | 23  |      |
|           |  |                  | $C_L = 150 pF$ | 18  | 33  |      |
|           |  | $V_{CC} = 6 V$   | $C_L = 50 pF$  | 11  | 20  |      |
|           |  |                  | $C_L = 150 pF$ | 15  | 28  |      |
| $t_{en}$  | From $\overline{OE}$ (input) to Y (output) | $V_{CC} = 2 V$   | $C_L = 50 pF$  | 75  | 150 | ns   |
|           |  |                  | $C_L = 150 pF$ | 100 | 200 |      |
|           |  | $V_{CC} = 4.5 V$ | $C_L = 50 pF$  | 15  | 30  |      |
|           |  |                  | $C_L = 150 pF$ | 20  | 40  |      |
|           |  | $V_{CC} = 6 V$   | $C_L = 50 pF$  | 13  | 26  |      |
|           |  |                  | $C_L = 150 pF$ | 17  | 34  |      |
| $t_{dis}$ | From $\overline{OE}$ (input) to Y (output) | $V_{CC} = 2 V$   | $C_L = 50 pF$  | 75  | 150 | ns   |
|           |  | $V_{CC} = 4.5 V$ | $C_L = 50 pF$  | 15  | 30  |      |
|           |  | $V_{CC} = 6 V$   | $C_L = 50 pF$  | 13  | 26  |      |
| $t_t$     | To Y (output)                              | $V_{CC} = 2 V$   | $C_L = 50 pF$  | 28  | 60  | ns   |
|           |  |                  | $C_L = 150 pF$ | 45  | 210 |      |
|           |  | $V_{CC} = 4.5 V$ | $C_L = 50 pF$  | 8   | 12  |      |
|           |  |                  | $C_L = 150 pF$ | 17  | 42  |      |
|           |  | $V_{CC} = 6 V$   | $C_L = 50 pF$  | 6   | 10  |      |
|           |  |                  | $C_L = 150 pF$ | 13  | 36  |      |

### 6.9 Switching Characteristics – $C_L = 50 \text{ pF}$

 over recommended operating free-air temperature range (unless otherwise noted; see [Figure 2](#))

| PARAMETER | TEST CONDITIONS                            |                          | MIN       | TYP | MAX | UNIT |
|-----------|--|--------------------------|-----------|-----|-----|------|
| $t_{pd}$  | From A (input) to Y (output)               | $V_{CC} = 2 \text{ V}$   | SN54HC244 |     | 170 | ns   |
|           |  |                          | SN74HC244 |     | 145 |      |
|           |  | $V_{CC} = 4.5 \text{ V}$ | SN54HC244 |     | 34  |      |
|           |  |                          | SN74HC244 |     | 29  |      |
|           |  | $V_{CC} = 6 \text{ V}$   | SN54HC244 |     | 29  |      |
|           |  |                          | SN74HC244 |     | 25  |      |
| $t_{en}$  | From $\overline{OE}$ (input) to Y (output) | $V_{CC} = 2 \text{ V}$   | SN54HC244 |     | 225 | ns   |
|           |  |                          | SN74HC244 |     | 190 |      |
|           |  | $V_{CC} = 4.5 \text{ V}$ | SN54HC244 |     | 45  |      |
|           |  |                          | SN74HC244 |     | 38  |      |
|           |  | $V_{CC} = 6 \text{ V}$   | SN54HC244 |     | 38  |      |
|           |  |                          | SN74HC244 |     | 32  |      |
| $t_{dis}$ | From $\overline{OE}$ (input) to Y (output) | $V_{CC} = 2 \text{ V}$   | SN54HC244 |     | 225 | ns   |
|           |  |                          | SN74HC244 |     | 190 |      |
|           |  | $V_{CC} = 4.5 \text{ V}$ | SN54HC244 |     | 45  |      |
|           |  |                          | SN74HC244 |     | 38  |      |
|           |  | $V_{CC} = 6 \text{ V}$   | SN54HC244 |     | 38  |      |
|           |  |                          | SN74HC244 |     | 32  |      |
| $t_t$     | To Y (output)                              | $V_{CC} = 2 \text{ V}$   | SN54HC244 |     | 90  | ns   |
|           |  |                          | SN74HC244 |     | 75  |      |
|           |  | $V_{CC} = 4.5 \text{ V}$ | SN54HC244 |     | 18  |      |
|           |  |                          | SN74HC244 |     | 15  |      |
|           |  | $V_{CC} = 6 \text{ V}$   | SN54HC244 |     | 15  |      |
|           |  |                          | SN74HC244 |     | 13  |      |

### 6.10 Switching Characteristics – $C_L = 150 \text{ pF}$

 over recommended operating free-air temperature range (unless otherwise noted; see [Figure 2](#))

| PARAMETER | TEST CONDITIONS                            |                          | MIN       | TYP | MAX | UNIT |
|-----------|--|--------------------------|-----------|-----|-----|------|
| $t_{pd}$  | From A (input) to Y (output)               | $V_{CC} = 2 \text{ V}$   | SN54HC244 |     | 245 | ns   |
|           |  |                          | SN74HC244 |     | 210 |      |
|           |  | $V_{CC} = 4.5 \text{ V}$ | SN54HC244 |     | 49  |      |
|           |  |                          | SN74HC244 |     | 42  |      |
|           |  | $V_{CC} = 6 \text{ V}$   | SN54HC244 |     | 42  |      |
|           |  |                          | SN74HC244 |     | 35  |      |
| $t_{en}$  | From $\overline{OE}$ (input) to Y (output) | $V_{CC} = 2 \text{ V}$   | SN54HC244 |     | 300 | ns   |
|           |  |                          | SN74HC244 |     | 250 |      |
|           |  | $V_{CC} = 4.5 \text{ V}$ | SN54HC244 |     | 60  |      |
|           |  |                          | SN74HC244 |     | 50  |      |
|           |  | $V_{CC} = 6 \text{ V}$   | SN54HC244 |     | 51  |      |
|           |  |                          | SN74HC244 |     | 43  |      |
| $t_t$     | To Y (output)                              | $V_{CC} = 2 \text{ V}$   | SN54HC244 |     | 315 | ns   |
|           |  |                          | SN74HC244 |     | 265 |      |
|           |  | $V_{CC} = 4.5 \text{ V}$ | SN54HC244 |     | 63  |      |
|           |  |                          | SN74HC244 |     | 53  |      |
|           |  | $V_{CC} = 6 \text{ V}$   | SN54HC244 |     | 53  |      |
|           |  |                          | SN74HC244 |     | 45  |      |

### 6.11 Typical Characteristic

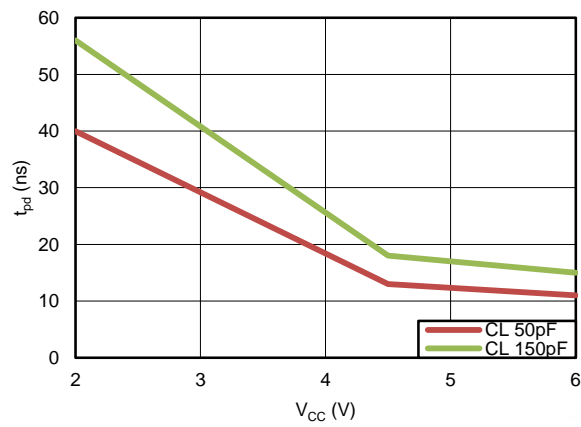

**Figure 1. Propagation Delay**

## 7 Parameter Measurement Information

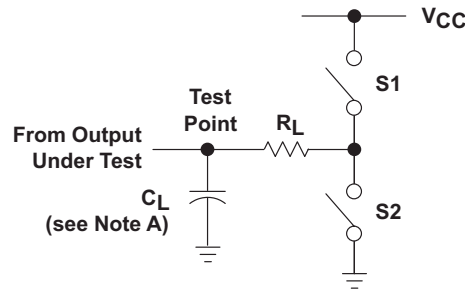

Figure 2. Load Circuit

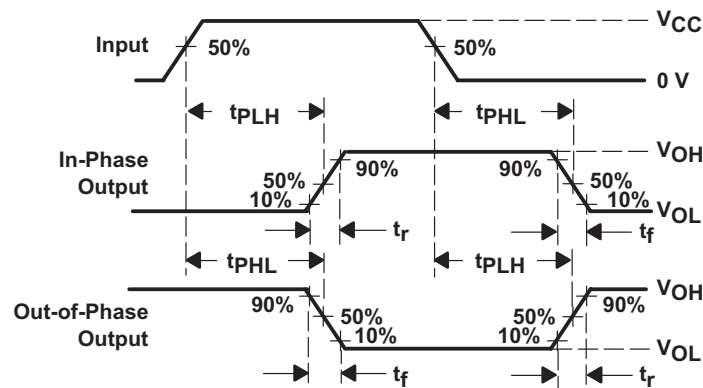

Figure 3. Propagation Delay and Output Transition Times

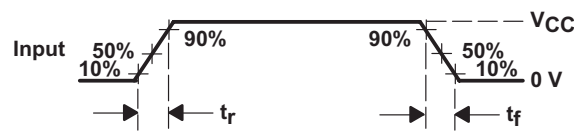

Figure 4. Input Rise and Fall Times

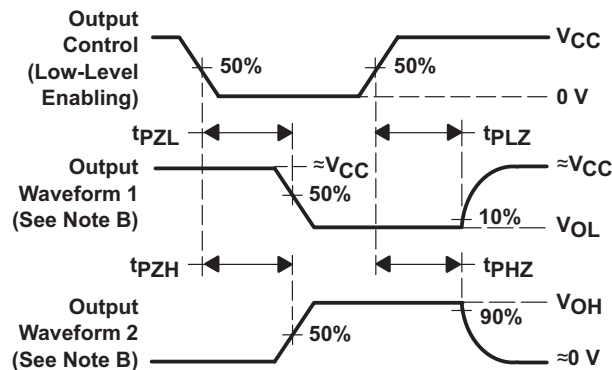

Figure 5. Enable and Disable Times for 3-State Outputs

NOTE:

A.  $C_L$  includes probe and test-fixture capacitance.

**Parameter Measurement Information (continued)**

B. Waveform 1 is for an output with internal conditions such that the output is low except when disabled by the output control. Waveform 2 is for an output with internal conditions such that the output is high except when disabled by the output control.

C. Phase relationships between waveforms were chosen arbitrarily. All input pulses are supplied by generators having the following characteristics:  $PRR \leq 1 \text{ MHz}$ ,  $Z_O = 50 \Omega$ ,  $t_r = 6 \text{ ns}$ ,  $t_f = 6 \text{ ns}$ .

D. The outputs are measured one at a time with one input transition per measurement.

E.  $t_{PLZ}$  and  $t_{PHZ}$  are the same as  $t_{dis}$ .

F.  $t_{PZL}$  and  $t_{PZH}$  are the same as  $t_{en}$ .

G.  $t_{PLH}$  and  $t_{PHL}$  are the same as  $t_{pd}$ .

**Table 1. Switching Information Table**

| PARAMETER         |           | RL           | CL              | S1     | S2     |
|-------------------|-----------|--------------|-----------------|--------|--------|
| $t_{en}$          | $t_{PZH}$ | 1 k $\Omega$ | 50 pF or 150 pF | Open   | Closed |
|                   | $t_{PZL}$ | 1 k $\Omega$ | 50 pF or 150 pF | Closed | Open   |
| $t_{dis}$         | $t_{PHZ}$ | 1 k $\Omega$ | 50 pF           | Open   | Closed |
|                   | $t_{PLZ}$ | 1 k $\Omega$ | 50 pF           | Closed | Open   |
| $t_{pd}$ or $t_t$ |           | —            | 50 pF or 150 pF | Open   | Open   |

## 8 Detailed Description

### 8.1 Overview

The SNx4HC244 device is organized as two 4-bit buffers and line drivers with separate output-enable ( $\overline{OE}$ ) inputs. When  $\overline{OE}$  is low, the device passes data from the A inputs to the Y outputs. When  $\overline{OE}$  is high, the outputs are in the high-impedance state. To ensure the high-impedance state during power up or power down,  $\overline{OE}$  should be tied to  $V_{CC}$  through a pullup resistor; the minimum value of the resistor is determined by the current-sinking capability of the driver.

### 8.2 Functional Block Diagram

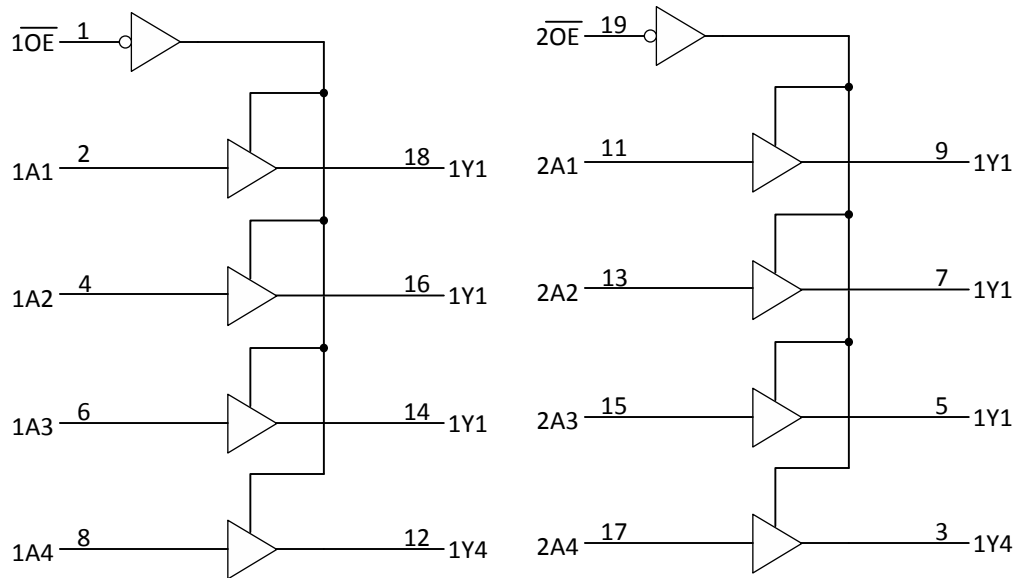

Copyright © 2016, Texas Instruments Incorporated

### 8.3 Feature Description

The SNx4HC244 has a wide operating voltage of 2 V to 6 V. Inputs accept voltage levels up to  $V_{CC}$ . This device has a low power consumption of  $I_{CC}$  80  $\mu$ A (maximum). The SNx4HC244 device can drive  $\pm 6$  mA at  $V_{CC}$  of 5 V.

### 8.4 Device Functional Modes

Table 2 lists the functions of the SNx4HC244.

**Table 2. Function Table  
(Each Buffer or Driver)**

| INPUTS          |   | OUTPUT |
|-----------------|---|--------|
| $\overline{OE}$ | A | Y      |
| L               | H | H      |
| L               | L | L      |
| H               | X | Z      |

## 9 Application and Implementation

### NOTE

Information in the following applications sections is not part of the TI component specification, and TI does not warrant its accuracy or completeness. TI's customers are responsible for determining suitability of components for their purposes. Customers should validate and test their design implementation to confirm system functionality.

### 9.1 Application Information

SN74HC244 is a high-drive CMOS device that can be used for a multitude of bus interface type applications where output drive or PCB trace length is a concern.

### 9.2 Typical Application

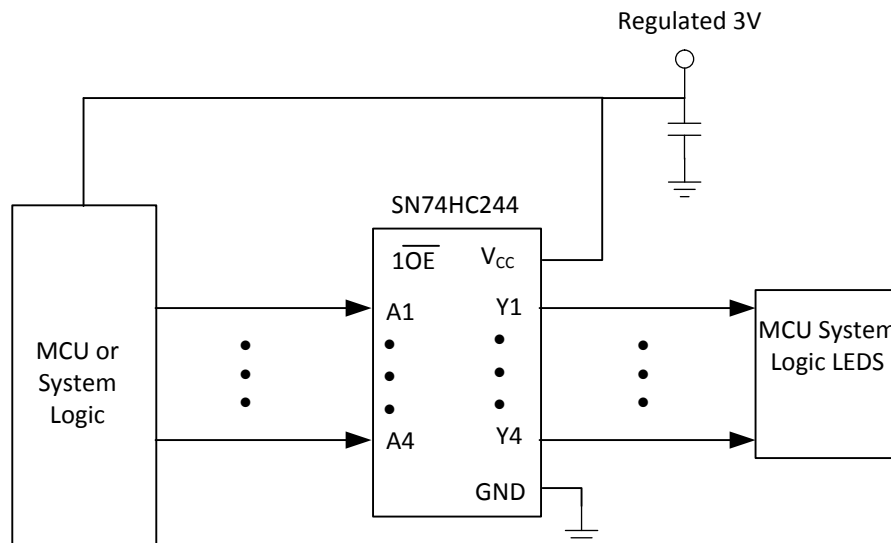

Copyright © 2016, Texas Instruments Incorporated

**Figure 6. SN74HC244 Application Schematic**

#### 9.2.1 Design Requirements

This device uses CMOS technology and has balanced output drive. Take care to avoid bus contention because it can drive currents that would exceed maximum limits. The high drive also creates fast edges into light loads so routing and load conditions should be considered to prevent ringing.

#### 9.2.2 Detailed Design Procedure

1. Recommended input conditions:
  - For rise time and fall time specifications, see  $\Delta t/\Delta V$  in [Recommended Operating Conditions](#).
  - For specified high and low levels, see  $V_{IH}$  and  $V_{IL}$  in [Recommended Operating Conditions](#).
2. Recommend output conditions:
  - Load currents should not exceed  $I_O$  max per output and should not exceed the continuous current through  $V_{CC}$  or GND total current for the part. These limits are located in [Absolute Maximum Ratings](#).
  - Outputs should not be pulled above  $V_{CC}$ .

## Typical Application (continued)

### 9.2.3 Application Curve

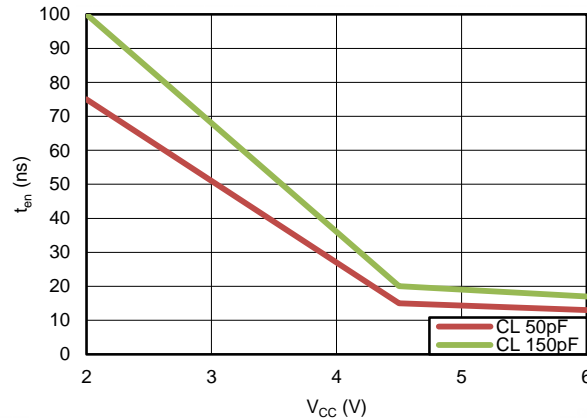

Figure 7. Enable Time

## 10 Power Supply Recommendations

The power supply can be any voltage between the MIN and MAX supply voltage rating located in the [Recommended Operating Conditions](#).

Each  $V_{CC}$  terminal should have a good bypass capacitor to prevent power disturbance. For devices with a single supply, TI recommends a  $0.1\text{-}\mu\text{F}$  capacitor. If there are multiple  $V_{CC}$  terminals, then TI recommends  $0.01\text{-}\mu\text{F}$  or  $0.022\text{-}\mu\text{F}$  capacitors for each power terminal. It is ok to parallel multiple bypass capacitors to reject different frequencies of noise. Multiple bypass capacitors may be paralleled to reject different frequencies of noise. The bypass capacitor should be installed as close to the power terminal as possible for the best results.

## 11 Layout

### 11.1 Layout Guidelines

When using multiple bit logic devices, inputs should not float. In many cases, functions or parts of functions of digital logic devices are unused. Some examples are when only two inputs of a triple-input and gate are used, or when only 3 of the 4-buffer gates are used. Such input pins should not be left unconnected because the undefined voltages at the outside connections result in undefined operational states.

Specified in [Figure 8](#) are rules that must be observed under all circumstances. All unused inputs of digital logic devices must be connected to a high or low bias to prevent them from floating. The logic level that should be applied to any particular unused input depends on the function of the device. Generally they will be tied to GND or  $V_{CC}$ , whichever makes more sense or is more convenient.

### 11.2 Layout Example

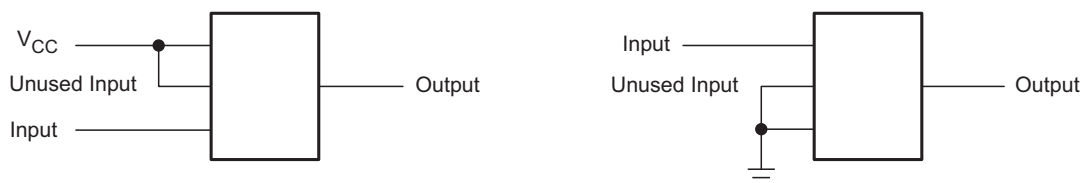

Figure 8. Layout Diagram

## 12 Device and Documentation Support

### 12.1 Related Links

[Table 3](#) lists quick access links. Categories include technical documents, support and community resources, tools and software, and quick access to sample or buy.

**Table 3. Related Links**

| PARTS     | PRODUCT FOLDER             | SAMPLE & BUY               | TECHNICAL DOCUMENTS        | TOOLS & SOFTWARE           | SUPPORT & COMMUNITY        |
|-----------|----------------------------|----------------------------|----------------------------|----------------------------|----------------------------|
| SN54HC244 | <a href="#">Click here</a> | <a href="#">Click here</a> | <a href="#">Click here</a> | <a href="#">Click here</a> | <a href="#">Click here</a> |
| SN74HC244 | <a href="#">Click here</a> | <a href="#">Click here</a> | <a href="#">Click here</a> | <a href="#">Click here</a> | <a href="#">Click here</a> |

### 12.2 Community Resources

The following links connect to TI community resources. Linked contents are provided "AS IS" by the respective contributors. They do not constitute TI specifications and do not necessarily reflect TI's views; see TI's [Terms of Use](#).

**TI E2E™ Online Community** *TI's Engineer-to-Engineer (E2E) Community*. Created to foster collaboration among engineers. At [e2e.ti.com](http://e2e.ti.com), you can ask questions, share knowledge, explore ideas and help solve problems with fellow engineers.

**Design Support** *TI's Design Support* Quickly find helpful E2E forums along with design support tools and contact information for technical support.

### 12.3 Trademarks

E2E is a trademark of Texas Instruments.  
All other trademarks are the property of their respective owners.

### 12.4 Electrostatic Discharge Caution



These devices have limited built-in ESD protection. The leads should be shorted together or the device placed in conductive foam during storage or handling to prevent electrostatic damage to the MOS gates.

### 12.5 Glossary

[SLYZ022](#) — *TI Glossary*.

This glossary lists and explains terms, acronyms, and definitions.

## 13 Mechanical, Packaging, and Orderable Information

The following pages include mechanical, packaging, and orderable information. This information is the most current data available for the designated devices. This data is subject to change without notice and revision of this document. For browser-based versions of this data sheet, refer to the left-hand navigation.

**PACKAGING INFORMATION**

| Orderable Device | Status<br>(1) | Package Type | Package Drawing | Pins | Package Qty | Eco Plan<br>(2)  | Lead finish/<br>Ball material<br>(6) | MSL Peak Temp<br>(3) | Op Temp (°C) | Device Marking<br>(4/5)             | Samples                 |
|------------------|---------------|--------------|-----------------|------|-------------|------------------|--------------------------------------|----------------------|--------------|-------------------------------------|-------------------------|
| 5962-8409601VRA  | ACTIVE        | CDIP         | J               | 20   | 1           | Non-RoHS & Green | SNPB                                 | N / A for Pkg Type   | -55 to 125   | 5962-8409601VRA<br>A<br>SNV54HC244J | <a href="#">Samples</a> |
| 5962-8409601VSA  | ACTIVE        | CFP          | W               | 20   | 25          | Non-RoHS & Green | SNPB                                 | N / A for Pkg Type   | -55 to 125   | 5962-8409601VSA<br>A<br>SNV54HC244W | <a href="#">Samples</a> |
| 84096012A        | ACTIVE        | LCCC         | FK              | 20   | 1           | Non-RoHS & Green | SNPB                                 | N / A for Pkg Type   | -55 to 125   | 84096012A<br>SNJ54HC<br>244FK       | <a href="#">Samples</a> |
| 8409601RA        | ACTIVE        | CDIP         | J               | 20   | 1           | Non-RoHS & Green | SNPB                                 | N / A for Pkg Type   | -55 to 125   | 8409601RA<br>SNJ54HC244J            | <a href="#">Samples</a> |
| 8409601SA        | ACTIVE        | CFP          | W               | 20   | 1           | Non-RoHS & Green | SNPB                                 | N / A for Pkg Type   | -55 to 125   | 8409601SA<br>SNJ54HC244W            | <a href="#">Samples</a> |
| JM38510/65705B2A | ACTIVE        | LCCC         | FK              | 20   | 1           | Non-RoHS & Green | SNPB                                 | N / A for Pkg Type   | -55 to 125   | JM38510/<br>65705B2A                | <a href="#">Samples</a> |
| JM38510/65705BRA | ACTIVE        | CDIP         | J               | 20   | 1           | Non-RoHS & Green | SNPB                                 | N / A for Pkg Type   | -55 to 125   | JM38510/<br>65705BRA                | <a href="#">Samples</a> |
| JM38510/65705BSA | ACTIVE        | CFP          | W               | 20   | 1           | Non-RoHS & Green | SNPB                                 | N / A for Pkg Type   | -55 to 125   | JM38510/<br>65705BSA                | <a href="#">Samples</a> |
| M38510/65705B2A  | ACTIVE        | LCCC         | FK              | 20   | 1           | Non-RoHS & Green | SNPB                                 | N / A for Pkg Type   | -55 to 125   | JM38510/<br>65705B2A                | <a href="#">Samples</a> |
| M38510/65705BRA  | ACTIVE        | CDIP         | J               | 20   | 1           | Non-RoHS & Green | SNPB                                 | N / A for Pkg Type   | -55 to 125   | JM38510/<br>65705BRA                | <a href="#">Samples</a> |
| M38510/65705BSA  | ACTIVE        | CFP          | W               | 20   | 1           | Non-RoHS & Green | SNPB                                 | N / A for Pkg Type   | -55 to 125   | JM38510/<br>65705BSA                | <a href="#">Samples</a> |
| SN54HC244J       | ACTIVE        | CDIP         | J               | 20   | 1           | Non-RoHS & Green | SNPB                                 | N / A for Pkg Type   | -55 to 125   | SN54HC244J                          | <a href="#">Samples</a> |
| SN74HC244APWR    | ACTIVE        | TSSOP        | PW              | 20   | 2000        | RoHS & Green     | NIPDAU                               | Level-1-260C-UNLIM   | -40 to 85    | HC244A                              | <a href="#">Samples</a> |
| SN74HC244DBR     | ACTIVE        | SSOP         | DB              | 20   | 2000        | RoHS & Green     | NIPDAU                               | Level-1-260C-UNLIM   | -40 to 85    | HC244                               | <a href="#">Samples</a> |
| SN74HC244DW      | ACTIVE        | SOIC         | DW              | 20   | 25          | RoHS & Green     | NIPDAU                               | Level-1-260C-UNLIM   | -40 to 85    | HC244                               | <a href="#">Samples</a> |
| SN74HC244DWE4    | ACTIVE        | SOIC         | DW              | 20   | 25          | RoHS & Green     | NIPDAU                               | Level-1-260C-UNLIM   | -40 to 85    | HC244                               | <a href="#">Samples</a> |

| Orderable Device  | Status<br>(1) | Package Type | Package Drawing | Pins | Package Qty | Eco Plan<br>(2)  | Lead finish/<br>Ball material<br>(6) | MSL Peak Temp<br>(3) | Op Temp (°C) | Device Marking<br>(4/5)       | Samples                 |
|-------------------|---------------|--------------|-----------------|------|-------------|------------------|--------------------------------------|----------------------|--------------|-------------------------------|-------------------------|
| SN74HC244DWR      | ACTIVE        | SOIC         | DW              | 20   | 2000        | RoHS & Green     | NIPDAU   SN                          | Level-1-260C-UNLIM   | -40 to 85    | HC244                         | <a href="#">Samples</a> |
| SN74HC244DWRE4    | ACTIVE        | SOIC         | DW              | 20   | 2000        | RoHS & Green     | NIPDAU                               | Level-1-260C-UNLIM   | -40 to 85    | HC244                         | <a href="#">Samples</a> |
| SN74HC244DWRG4    | ACTIVE        | SOIC         | DW              | 20   | 2000        | RoHS & Green     | NIPDAU                               | Level-1-260C-UNLIM   | -40 to 85    | HC244                         | <a href="#">Samples</a> |
| SN74HC244N        | ACTIVE        | PDIP         | N               | 20   | 20          | RoHS & Green     | NIPDAU                               | N / A for Pkg Type   | -40 to 85    | SN74HC244N                    | <a href="#">Samples</a> |
| SN74HC244NE4      | ACTIVE        | PDIP         | N               | 20   | 20          | RoHS & Green     | NIPDAU                               | N / A for Pkg Type   | -40 to 85    | SN74HC244N                    | <a href="#">Samples</a> |
| SN74HC244NSR      | ACTIVE        | SO           | NS              | 20   | 2000        | RoHS & Green     | NIPDAU                               | Level-1-260C-UNLIM   | -40 to 85    | HC244                         | <a href="#">Samples</a> |
| SN74HC244NSRG4    | ACTIVE        | SO           | NS              | 20   | 2000        | RoHS & Green     | NIPDAU                               | Level-1-260C-UNLIM   | -40 to 85    | HC244                         | <a href="#">Samples</a> |
| SN74HC244PW       | ACTIVE        | TSSOP        | PW              | 20   | 70          | RoHS & Green     | NIPDAU                               | Level-1-260C-UNLIM   | -40 to 85    | HC244                         | <a href="#">Samples</a> |
| SN74HC244PWE4     | ACTIVE        | TSSOP        | PW              | 20   | 70          | RoHS & Green     | NIPDAU                               | Level-1-260C-UNLIM   | -40 to 85    | HC244                         | <a href="#">Samples</a> |
| SN74HC244PWG4     | ACTIVE        | TSSOP        | PW              | 20   | 70          | RoHS & Green     | NIPDAU                               | Level-1-260C-UNLIM   | -40 to 85    | HC244                         | <a href="#">Samples</a> |
| SN74HC244PWR      | ACTIVE        | TSSOP        | PW              | 20   | 2000        | RoHS & Green     | NIPDAU                               | Level-1-260C-UNLIM   | -40 to 85    | HC244                         | <a href="#">Samples</a> |
| SN74HC244PWRE4    | ACTIVE        | TSSOP        | PW              | 20   | 2000        | RoHS & Green     | NIPDAU                               | Level-1-260C-UNLIM   | -40 to 85    | HC244                         | <a href="#">Samples</a> |
| SN74HC244PWRG4    | ACTIVE        | TSSOP        | PW              | 20   | 2000        | RoHS & Green     | NIPDAU                               | Level-1-260C-UNLIM   | -40 to 85    | HC244                         | <a href="#">Samples</a> |
| SN74HC244PWT      | ACTIVE        | TSSOP        | PW              | 20   | 250         | RoHS & Green     | NIPDAU                               | Level-1-260C-UNLIM   | -40 to 85    | HC244                         | <a href="#">Samples</a> |
| SN74HC244QDWRG4Q1 | ACTIVE        | SOIC         | DW              | 20   | 2000        | RoHS & Green     | NIPDAU                               | Level-1-260C-UNLIM   |              | HC244Q                        | <a href="#">Samples</a> |
| SNJ54HC244FK      | ACTIVE        | LCCC         | FK              | 20   | 1           | Non-RoHS & Green | SNPB                                 | N / A for Pkg Type   | -55 to 125   | 84096012A<br>SNJ54HC<br>244FK | <a href="#">Samples</a> |
| SNJ54HC244J       | ACTIVE        | CDIP         | J               | 20   | 1           | Non-RoHS & Green | SNPB                                 | N / A for Pkg Type   | -55 to 125   | 8409601RA<br>SNJ54HC244J      | <a href="#">Samples</a> |
| SNJ54HC244W       | ACTIVE        | CFP          | W               | 20   | 1           | Non-RoHS & Green | SNPB                                 | N / A for Pkg Type   | -55 to 125   | 8409601SA<br>SNJ54HC244W      | <a href="#">Samples</a> |

(1) The marketing status values are defined as follows:

**ACTIVE:** Product device recommended for new designs.

**LIFEBUY:** TI has announced that the device will be discontinued, and a lifetime-buy period is in effect.

**NRND:** Not recommended for new designs. Device is in production to support existing customers, but TI does not recommend using this part in a new design.

**PREVIEW:** Device has been announced but is not in production. Samples may or may not be available.

**OBSOLETE:** TI has discontinued the production of the device.

<sup>(2)</sup> **RoHS:** TI defines "RoHS" to mean semiconductor products that are compliant with the current EU RoHS requirements for all 10 RoHS substances, including the requirement that RoHS substance do not exceed 0.1% by weight in homogeneous materials. Where designed to be soldered at high temperatures, "RoHS" products are suitable for use in specified lead-free processes. TI may reference these types of products as "Pb-Free".

**RoHS Exempt:** TI defines "RoHS Exempt" to mean products that contain lead but are compliant with EU RoHS pursuant to a specific EU RoHS exemption.

**Green:** TI defines "Green" to mean the content of Chlorine (Cl) and Bromine (Br) based flame retardants meet JS709B low halogen requirements of <=1000ppm threshold. Antimony trioxide based flame retardants must also meet the <=1000ppm threshold requirement.

<sup>(3)</sup> MSL, Peak Temp. - The Moisture Sensitivity Level rating according to the JEDEC industry standard classifications, and peak solder temperature.

<sup>(4)</sup> There may be additional marking, which relates to the logo, the lot trace code information, or the environmental category on the device.

<sup>(5)</sup> Multiple Device Markings will be inside parentheses. Only one Device Marking contained in parentheses and separated by a "~" will appear on a device. If a line is indented then it is a continuation of the previous line and the two combined represent the entire Device Marking for that device.

<sup>(6)</sup> Lead finish/Ball material - Orderable Devices may have multiple material finish options. Finish options are separated by a vertical ruled line. Lead finish/Ball material values may wrap to two lines if the finish value exceeds the maximum column width.

**Important Information and Disclaimer:**The information provided on this page represents TI's knowledge and belief as of the date that it is provided. TI bases its knowledge and belief on information provided by third parties, and makes no representation or warranty as to the accuracy of such information. Efforts are underway to better integrate information from third parties. TI has taken and continues to take reasonable steps to provide representative and accurate information but may not have conducted destructive testing or chemical analysis on incoming materials and chemicals. TI and TI suppliers consider certain information to be proprietary, and thus CAS numbers and other limited information may not be available for release.

In no event shall TI's liability arising out of such information exceed the total purchase price of the TI part(s) at issue in this document sold by TI to Customer on an annual basis.

**OTHER QUALIFIED VERSIONS OF SN54HC244, SN54HC244-SP, SN74HC244 :**

- Catalog : [SN74HC244](#), [SN54HC244](#)
- Automotive : [SN74HC244-Q1](#), [SN74HC244-Q1](#)
- Enhanced Product : [SN74HC244-EP](#), [SN74HC244-EP](#)
- Military : [SN54HC244](#)
- Space : [SN54HC244-SP](#)

## NOTE: Qualified Version Definitions:

- Catalog - TI's standard catalog product
- Automotive - Q100 devices qualified for high-reliability automotive applications targeting zero defects
- Enhanced Product - Supports Defense, Aerospace and Medical Applications
- Military - QML certified for Military and Defense Applications
- Space - Radiation tolerant, ceramic packaging and qualified for use in Space-based application

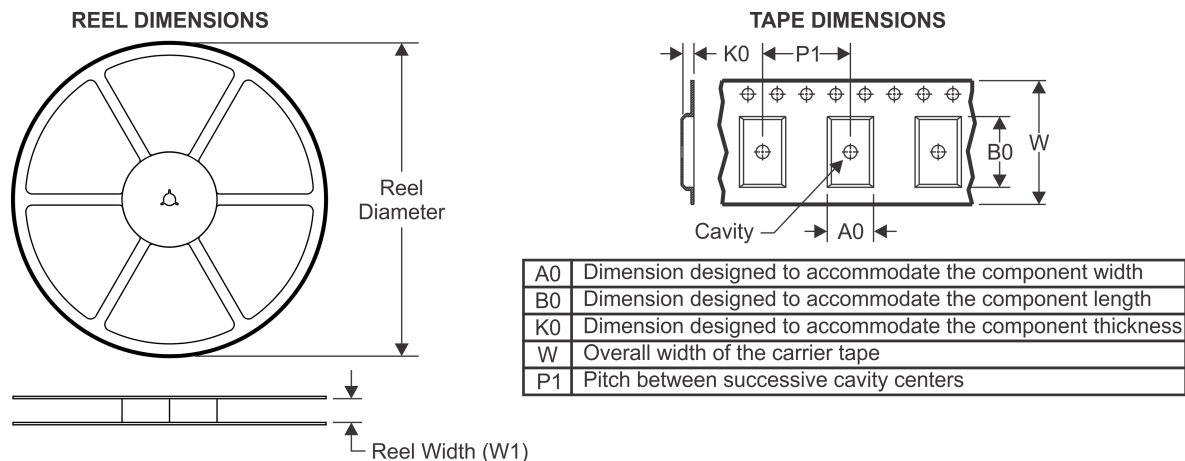
**TAPE AND REEL INFORMATION**

**QUADRANT ASSIGNMENTS FOR PIN 1 ORIENTATION IN TAPE**



\*All dimensions are nominal

| Device            | Package Type | Package Drawing | Pins | SPQ  | Reel Diameter (mm) | Reel Width W1 (mm) | A0 (mm) | B0 (mm) | K0 (mm) | P1 (mm) | W (mm) | Pin1 Quadrant |
|-------------------|--------------|-----------------|------|------|--------------------|--------------------|---------|---------|---------|---------|--------|---------------|
| SN74HC244APWR     | TSSOP        | PW              | 20   | 2000 | 330.0              | 16.4               | 6.95    | 7.1     | 1.6     | 8.0     | 16.0   | Q1            |
| SN74HC244DBR      | SSOP         | DB              | 20   | 2000 | 330.0              | 16.4               | 8.2     | 7.5     | 2.5     | 12.0    | 16.0   | Q1            |
| SN74HC244DWR      | SOIC         | DW              | 20   | 2000 | 330.0              | 24.4               | 10.8    | 13.3    | 2.7     | 12.0    | 24.0   | Q1            |
| SN74HC244DWR      | SOIC         | DW              | 20   | 2000 | 330.0              | 24.4               | 10.8    | 13.3    | 2.7     | 12.0    | 24.0   | Q1            |
| SN74HC244DWRG4    | SOIC         | DW              | 20   | 2000 | 330.0              | 24.4               | 10.8    | 13.3    | 2.7     | 12.0    | 24.0   | Q1            |
| SN74HC244NSR      | SO           | NS              | 20   | 2000 | 330.0              | 24.4               | 8.4     | 13.0    | 2.5     | 12.0    | 24.0   | Q1            |
| SN74HC244PWR      | TSSOP        | PW              | 20   | 2000 | 330.0              | 16.4               | 6.95    | 7.0     | 1.4     | 8.0     | 16.0   | Q1            |
| SN74HC244PWT      | TSSOP        | PW              | 20   | 250  | 330.0              | 16.4               | 6.95    | 7.0     | 1.4     | 8.0     | 16.0   | Q1            |
| SN74HC244QDWRG4Q1 | SOIC         | DW              | 20   | 2000 | 330.0              | 24.4               | 10.8    | 13.3    | 2.7     | 12.0    | 24.0   | Q1            |

**TAPE AND REEL BOX DIMENSIONS**

\*All dimensions are nominal

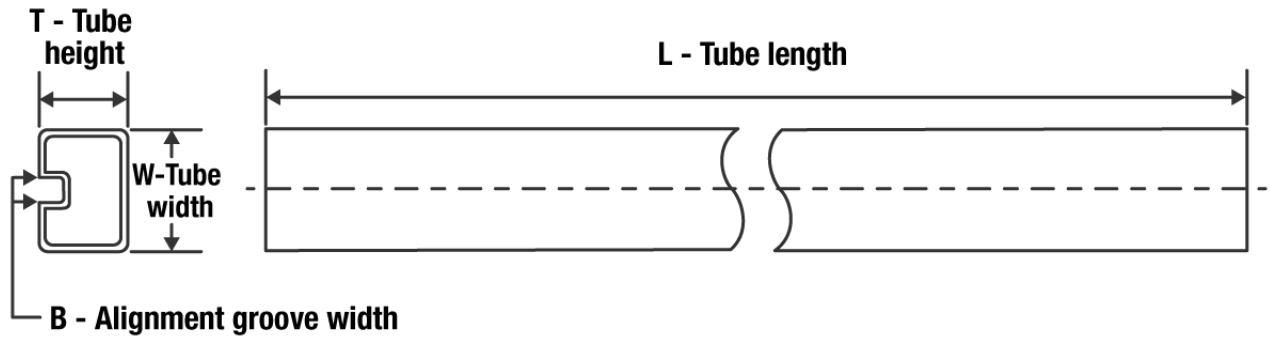
| Device            | Package Type | Package Drawing | Pins | SPQ  | Length (mm) | Width (mm) | Height (mm) |
|-------------------|--------------|-----------------|------|------|-------------|------------|-------------|
| SN74HC244APWR     | TSSOP        | PW              | 20   | 2000 | 853.0       | 449.0      | 35.0        |
| SN74HC244DBR      | SSOP         | DB              | 20   | 2000 | 853.0       | 449.0      | 35.0        |
| SN74HC244DWR      | SOIC         | DW              | 20   | 2000 | 600.0       | 144.0      | 84.0        |
| SN74HC244DWR      | SOIC         | DW              | 20   | 2000 | 350.0       | 350.0      | 43.0        |
| SN74HC244DWRG4    | SOIC         | DW              | 20   | 2000 | 367.0       | 367.0      | 45.0        |
| SN74HC244NSR      | SO           | NS              | 20   | 2000 | 367.0       | 367.0      | 45.0        |
| SN74HC244PWR      | TSSOP        | PW              | 20   | 2000 | 853.0       | 449.0      | 35.0        |
| SN74HC244PWT      | TSSOP        | PW              | 20   | 250  | 853.0       | 449.0      | 35.0        |
| SN74HC244QDWRG4Q1 | SOIC         | DW              | 20   | 2000 | 367.0       | 367.0      | 45.0        |

**TUBE**

\*All dimensions are nominal

| Device           | Package Name | Package Type | Pins | SPQ | L (mm) | W (mm) | T (μm) | B (mm) |
|------------------|--------------|--------------|------|-----|--------|--------|--------|--------|
| 5962-8409601VSA  | W            | CFP          | 20   | 25  | 506.98 | 26.16  | 6220   | NA     |
| 84096012A        | FK           | LCCC         | 20   | 1   | 506.98 | 12.06  | 2030   | NA     |
| JM38510/65705B2A | FK           | LCCC         | 20   | 1   | 506.98 | 12.06  | 2030   | NA     |
| M38510/65705B2A  | FK           | LCCC         | 20   | 1   | 506.98 | 12.06  | 2030   | NA     |
| SN74HC244DW      | DW           | SOIC         | 20   | 25  | 507    | 12.83  | 5080   | 6.6    |
| SN74HC244DWE4    | DW           | SOIC         | 20   | 25  | 507    | 12.83  | 5080   | 6.6    |
| SN74HC244N       | N            | PDIP         | 20   | 20  | 506    | 13.97  | 11230  | 4.32   |
| SN74HC244NE4     | N            | PDIP         | 20   | 20  | 506    | 13.97  | 11230  | 4.32   |
| SN74HC244PW      | PW           | TSSOP        | 20   | 70  | 530    | 10.2   | 3600   | 3.5    |
| SN74HC244PWE4    | PW           | TSSOP        | 20   | 70  | 530    | 10.2   | 3600   | 3.5    |
| SN74HC244PWG4    | PW           | TSSOP        | 20   | 70  | 530    | 10.2   | 3600   | 3.5    |
| SNJ54HC244FK     | FK           | LCCC         | 20   | 1   | 506.98 | 12.06  | 2030   | NA     |

W (R-GDFP-F20)

CERAMIC DUAL FLATPACK



- NOTES:
- All linear dimensions are in inches (millimeters).
  - This drawing is subject to change without notice.
  - This package can be hermetically sealed with a ceramic lid using glass frit.
  - Index point is provided on cap for terminal identification only.
  - Falls within Mil-Std 1835 GDFP2-F20

# PW0020A



# PACKAGE OUTLINE

## TSSOP - 1.2 mm max height

SMALL OUTLINE PACKAGE



4220206/A 02/2017

### NOTES:

1. All linear dimensions are in millimeters. Any dimensions in parenthesis are for reference only. Dimensioning and tolerancing per ASME Y14.5M.
2. This drawing is subject to change without notice.
3. This dimension does not include mold flash, protrusions, or gate burrs. Mold flash, protrusions, or gate burrs shall not exceed 0.15 mm per side.
4. This dimension does not include interlead flash. Interlead flash shall not exceed 0.25 mm per side.
5. Reference JEDEC registration MO-153.

# EXAMPLE BOARD LAYOUT

PW0020A

TSSOP - 1.2 mm max height

SMALL OUTLINE PACKAGE



LAND PATTERN EXAMPLE  
EXPOSED METAL SHOWN  
SCALE: 10X



4220206/A 02/2017

NOTES: (continued)

- 6. Publication IPC-7351 may have alternate designs.
- 7. Solder mask tolerances between and around signal pads can vary based on board fabrication site.

# EXAMPLE STENCIL DESIGN

PW0020A

TSSOP - 1.2 mm max height

SMALL OUTLINE PACKAGE



SOLDER PASTE EXAMPLE  
BASED ON 0.125 mm THICK STENCIL  
SCALE: 10X

4220206/A 02/2017

NOTES: (continued)

8. Laser cutting apertures with trapezoidal walls and rounded corners may offer better paste release. IPC-7525 may have alternate design recommendations.
9. Board assembly site may have different recommendations for stencil design.

PW (R-PDSO-G20)

PLASTIC SMALL OUTLINE



- NOTES:
- A. All linear dimensions are in millimeters.
  - B. This drawing is subject to change without notice.
  - C. Publication IPC-7351 is recommended for alternate design.
  - D. Laser cutting apertures with trapezoidal walls and also rounding corners will offer better paste release. Customers should contact their board assembly site for stencil design recommendations. Refer to IPC-7525 for other stencil recommendations.
  - E. Customers should contact their board fabrication site for solder mask tolerances between and around signal pads.

FK (S-CQCC-N\*\*)

LEADLESS CERAMIC CHIP CARRIER

28 TERMINAL SHOWN



| NO. OF TERMINALS ** | A                |                  | B                |                  |
|---------------------|------------------|------------------|------------------|------------------|
|                     | MIN              | MAX              | MIN              | MAX              |
| 20                  | 0.342<br>(8,69)  | 0.358<br>(9,09)  | 0.307<br>(7,80)  | 0.358<br>(9,09)  |
| 28                  | 0.442<br>(11,23) | 0.458<br>(11,63) | 0.406<br>(10,31) | 0.458<br>(11,63) |
| 44                  | 0.640<br>(16,26) | 0.660<br>(16,76) | 0.495<br>(12,58) | 0.560<br>(14,22) |
| 52                  | 0.740<br>(18,78) | 0.761<br>(19,32) | 0.495<br>(12,58) | 0.560<br>(14,22) |
| 68                  | 0.938<br>(23,83) | 0.962<br>(24,43) | 0.850<br>(21,6)  | 0.858<br>(21,8)  |
| 84                  | 1.141<br>(28,99) | 1.165<br>(29,59) | 1.047<br>(26,6)  | 1.063<br>(27,0)  |



4040140/D 01/11

- NOTES:
- All linear dimensions are in inches (millimeters).
  - This drawing is subject to change without notice.
  - This package can be hermetically sealed with a metal lid.
  - Falls within JEDEC MS-004

# DB0020A



# PACKAGE OUTLINE

## SSOP - 2 mm max height

SMALL OUTLINE PACKAGE



4214851/B 08/2019

### NOTES:

1. All linear dimensions are in millimeters. Any dimensions in parenthesis are for reference only. Dimensioning and tolerancing per ASME Y14.5M.
2. This drawing is subject to change without notice.
3. This dimension does not include mold flash, protrusions, or gate burrs. Mold flash, protrusions, or gate burrs shall not exceed 0.15 mm per side.
4. This dimension does not include interlead flash. Interlead flash shall not exceed 0.25 mm per side.
5. Reference JEDEC registration MO-150.

# EXAMPLE BOARD LAYOUT

DB0020A

SSOP - 2 mm max height

SMALL OUTLINE PACKAGE



LAND PATTERN EXAMPLE  
EXPOSED METAL SHOWN  
SCALE: 10X



4214851/B 08/2019

NOTES: (continued)

- 6. Publication IPC-7351 may have alternate designs.
- 7. Solder mask tolerances between and around signal pads can vary based on board fabrication site.

# EXAMPLE STENCIL DESIGN

DB0020A

SSOP - 2 mm max height

SMALL OUTLINE PACKAGE

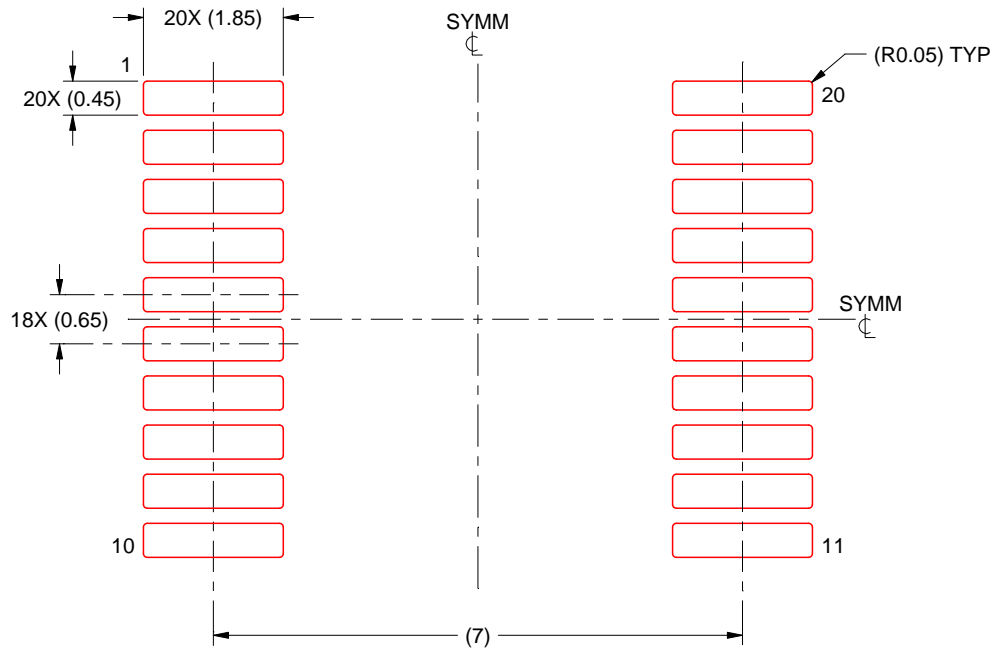

SOLDER PASTE EXAMPLE  
BASED ON 0.125 mm THICK STENCIL  
SCALE: 10X

4214851/B 08/2019

NOTES: (continued)

8. Laser cutting apertures with trapezoidal walls and rounded corners may offer better paste release. IPC-7525 may have alternate design recommendations.
9. Board assembly site may have different recommendations for stencil design.

# MECHANICAL DATA

NS (R-PDSO-G\*\*)

PLASTIC SMALL-OUTLINE PACKAGE

14-PINS SHOWN



- NOTES:
- A. All linear dimensions are in millimeters.
  - B. This drawing is subject to change without notice.
  - C. Body dimensions do not include mold flash or protrusion, not to exceed 0,15.

# J (R-GDIP-T\*\*)

14 LEADS SHOWN

# CERAMIC DUAL IN-LINE PACKAGE



| DIM \ PINS ** | 14                     | 16                     | 18                     | 20                     |
|---------------|------------------------|------------------------|------------------------|------------------------|
| A             | 0.300<br>(7,62)<br>BSC | 0.300<br>(7,62)<br>BSC | 0.300<br>(7,62)<br>BSC | 0.300<br>(7,62)<br>BSC |
| B MAX         | 0.785<br>(19,94)       | .840<br>(21,34)        | 0.960<br>(24,38)       | 1.060<br>(26,92)       |
| B MIN         | —                      | —                      | —                      | —                      |
| C MAX         | 0.300<br>(7,62)        | 0.300<br>(7,62)        | 0.310<br>(7,87)        | 0.300<br>(7,62)        |
| C MIN         | 0.245<br>(6,22)        | 0.245<br>(6,22)        | 0.220<br>(5,59)        | 0.245<br>(6,22)        |



4040083/F 03/03

- NOTES:
- All linear dimensions are in inches (millimeters).
  - This drawing is subject to change without notice.
  - This package is hermetically sealed with a ceramic lid using glass frit.
  - Index point is provided on cap for terminal identification only on press ceramic glass frit seal only.
  - Falls within MIL STD 1835 GDIP1-T14, GDIP1-T16, GDIP1-T18 and GDIP1-T20.

N (R-PDIP-T\*\*)

PLASTIC DUAL-IN-LINE PACKAGE

16 PINS SHOWN



4040049/E 12/2002

- NOTES:
- A. All linear dimensions are in inches (millimeters).
  - B. This drawing is subject to change without notice.
  - $\triangle C$  Falls within JEDEC MS-001, except 18 and 20 pin minimum body length (Dim A).
  - $\triangle D$  The 20 pin end lead shoulder width is a vendor option, either half or full width.

# DW0020A



# PACKAGE OUTLINE

## SOIC - 2.65 mm max height

SOIC



4220724/A 05/2016

**NOTES:**

1. All linear dimensions are in millimeters. Dimensions in parenthesis are for reference only. Dimensioning and tolerancing per ASME Y14.5M.
2. This drawing is subject to change without notice.
3. This dimension does not include mold flash, protrusions, or gate burrs. Mold flash, protrusions, or gate burrs shall not exceed 0.15 mm per side.
4. This dimension does not include interlead flash. Interlead flash shall not exceed 0.43 mm per side.
5. Reference JEDEC registration MS-013.

# EXAMPLE BOARD LAYOUT

DW0020A

SOIC - 2.65 mm max height

SOIC



LAND PATTERN EXAMPLE  
SCALE:6X



SOLDER MASK DETAILS

4220724/A 05/2016

NOTES: (continued)

- 6. Publication IPC-7351 may have alternate designs.
- 7. Solder mask tolerances between and around signal pads can vary based on board fabrication site.

# EXAMPLE STENCIL DESIGN

DW0020A

SOIC - 2.65 mm max height

SOIC



SOLDER PASTE EXAMPLE  
BASED ON 0.125 mm THICK STENCIL  
SCALE:6X

4220724/A 05/2016

NOTES: (continued)

8. Laser cutting apertures with trapezoidal walls and rounded corners may offer better paste release. IPC-7525 may have alternate design recommendations.
9. Board assembly site may have different recommendations for stencil design.

## IMPORTANT NOTICE AND DISCLAIMER

TI PROVIDES TECHNICAL AND RELIABILITY DATA (INCLUDING DATA SHEETS), DESIGN RESOURCES (INCLUDING REFERENCE DESIGNS), APPLICATION OR OTHER DESIGN ADVICE, WEB TOOLS, SAFETY INFORMATION, AND OTHER RESOURCES "AS IS" AND WITH ALL FAULTS, AND DISCLAIMS ALL WARRANTIES, EXPRESS AND IMPLIED, INCLUDING WITHOUT LIMITATION ANY IMPLIED WARRANTIES OF MERCHANTABILITY, FITNESS FOR A PARTICULAR PURPOSE OR NON-INFRINGEMENT OF THIRD PARTY INTELLECTUAL PROPERTY RIGHTS.

These resources are intended for skilled developers designing with TI products. You are solely responsible for (1) selecting the appropriate TI products for your application, (2) designing, validating and testing your application, and (3) ensuring your application meets applicable standards, and any other safety, security, regulatory or other requirements.

These resources are subject to change without notice. TI grants you permission to use these resources only for development of an application that uses the TI products described in the resource. Other reproduction and display of these resources is prohibited. No license is granted to any other TI intellectual property right or to any third party intellectual property right. TI disclaims responsibility for, and you will fully indemnify TI and its representatives against, any claims, damages, costs, losses, and liabilities arising out of your use of these resources.

TI's products are provided subject to [TI's Terms of Sale](#) or other applicable terms available either on [ti.com](http://ti.com) or provided in conjunction with such TI products. TI's provision of these resources does not expand or otherwise alter TI's applicable warranties or warranty disclaimers for TI products.

TI objects to and rejects any additional or different terms you may have proposed.

Mailing Address: Texas Instruments, Post Office Box 655303, Dallas, Texas 75265  
Copyright © 2022, Texas Instruments Incorporated