

LM4675 Boomer[®] Audio Power Amplifier Series Ultra-Low EMI, Filterless, 2.65W, Mono, Class D Audio Power Amplifier with Spread Spectrum

Check for Samples: [LM4675](#), [LM4675SDBD](#), [LM4675TLBD](#)

FEATURES

- **Spread Spectrum Architecture Reduces EMI**
- **Mono Class D Operation**
- **No Output Filter Required for Inductive Loads**
- **Externally Configurable Gain**
- **Very Fast Turn On Time: 17 μ s (typ)**
- **Minimum External Components**
- **"Click and Pop" Suppression Circuitry**
- **Micro-Power Shutdown Mode**
- **Available in Space-Saving 0.5mm Pitch DSBGA and WSON Packages**

APPLICATIONS

- **Mobile Phones**
- **PDA's**
- **Portable Electronic Devices**

KEY SPECIFICATIONS

- **Efficiency at 3.6V, 400mW into 8 Ω Speaker: 89% (typ)**
- **Efficiency at 3.6V, 100mW into 8 Ω Speaker: 80% (typ)**
- **Efficiency at 5V, 1W into 8 Ω Speaker: 89% (typ)**
- **Quiescent Current, 3.6V Supply: 2.2mA (typ)**
- **Total Shutdown Power Supply Current: 0.01 μ A (typ)**
- **Single Supply Range: 2.4V to 5.5V**
- **PSRR, f = 217Hz: 82dB**

DESCRIPTION

The LM4675 is a single supply, high efficiency, 2.65W, mono, Class D audio amplifier. A spread spectrum, filterless PWM architecture reduces EMI and eliminates the output filter, reducing external component count, board area consumption, system cost, and simplifying design.

The LM4675 is designed to meet the demands of mobile phones and other portable communication devices. Operating on a single 5V supply, it is capable of driving a 4 Ω speaker load at a continuous average output of 2.2W with less than 1% THD+N. Its flexible power supply requirements allow operation from 2.4V to 5.5V. The wide band spread spectrum architecture of the LM4675 reduces EMI-radiated emissions due to the modulator frequency.

The LM4675 has high efficiency with speaker loads compared to a typical Class AB amplifier. With a 3.6V supply driving an 8 Ω speaker, the IC's efficiency for a 100mW power level is 80%, reaching 89% at 400mW output power.

The LM4675 features a low-power consumption shutdown mode. Shutdown may be enabled by driving the Shutdown pin to a logic low (GND).

The gain of the LM4675 is externally configurable which allows independent gain control from multiple sources by summing the signals. Output short circuit and thermal overload protection prevent the device from damage during fault conditions.



Please be aware that an important notice concerning availability, standard warranty, and use in critical applications of Texas Instruments semiconductor products and disclaimers thereto appears at the end of this data sheet.

All trademarks are the property of their respective owners.

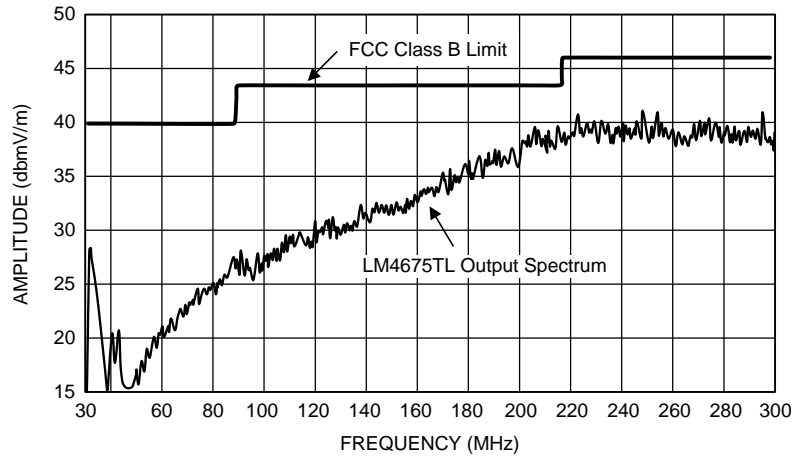

Figure 1. LM4675 Rf Emissions — 6in cable

Typical Application

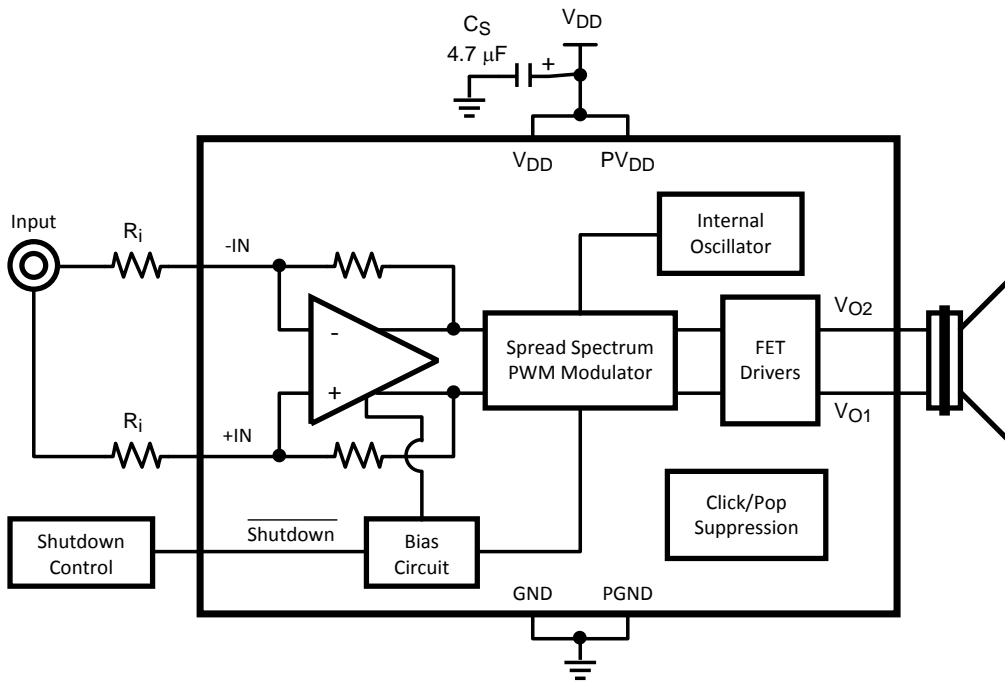

Figure 2. Typical Audio Amplifier Application Circuit

Connection Diagrams

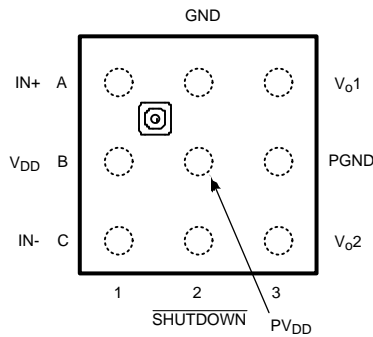

Figure 3. 9-Bump DSBGA - Top View
See YZR0009 Package

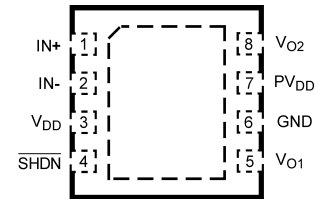

Figure 4. 8-Pin WSON - Top View
See NGQ0008A Package



These devices have limited built-in ESD protection. The leads should be shorted together or the device placed in conductive foam during storage or handling to prevent electrostatic damage to the MOS gates.

Absolute Maximum Ratings⁽¹⁾⁽²⁾⁽³⁾

Supply Voltage ⁽¹⁾	6.0V				
Storage Temperature	-65°C to +150°C				
Voltage at Any Input Pin	$V_{DD} + 0.3V \geq V \geq GND - 0.3V$				
Power Dissipation ⁽⁴⁾	Internally Limited				
ESD Susceptibility, all other pins ⁽⁵⁾	2.0kV				
ESD Susceptibility ⁽⁶⁾	200V				
Junction Temperature (T_{JMAX})	150°C				
Thermal Resistance	<table border="1"> <tbody> <tr> <td>θ_{JA} (DSBGA)</td> <td>220°C/W</td> </tr> <tr> <td>θ_{JA} (WSON)</td> <td>73°C/W</td> </tr> </tbody> </table>	θ_{JA} (DSBGA)	220°C/W	θ_{JA} (WSON)	73°C/W
θ_{JA} (DSBGA)	220°C/W				
θ_{JA} (WSON)	73°C/W				
Soldering Information	See (SNVA009) "microSMD Wafers Level Chip Scale Package."				

- (1) All voltages are measured with respect to the ground pin, unless otherwise specified.
- (2) *Absolute Maximum Ratings* indicate limits beyond which damage to the device may occur. *Operating Ratings* indicate conditions for which the device is functional, but do not ensure specific performance limits. *Electrical Characteristics* state DC and AC electrical specifications under particular test conditions which ensure specific performance limits. This assumes that the device is within the Operating Ratings. Specifications are not ensured for parameters where no limit is given, however, the typical value is a good indication of device performance.
- (3) If Military/Aerospace specified devices are required, please contact the TI Sales Office/ Distributors for availability and specifications.
- (4) The maximum power dissipation must be derated at elevated temperatures and is dictated by T_{JMAX} , θ_{JA} , and the ambient temperature T_A . The maximum allowable power dissipation is $P_{DMAX} = (T_{JMAX} - T_A) / \theta_{JA}$ or the number given in Absolute Maximum Ratings, whichever is lower. For the LM4675, $T_{JMAX} = 150^\circ\text{C}$. The typical θ_{JA} is 99.1°C/W for the DSBGA package.
- (5) Human body model, 100pF discharged through a 1.5kΩ resistor.
- (6) Machine Model, 220pF – 240pF discharged through all pins.

Operating Ratings⁽¹⁾⁽²⁾

Temperature Range $T_{MIN} \leq T_A \leq T_{MAX}$	$-40^\circ\text{C} \leq T_A \leq 85^\circ\text{C}$
Supply Voltage	$2.4V \leq V_{DD} \leq 5.5V$

- (1) All voltages are measured with respect to the ground pin, unless otherwise specified.
- (2) *Absolute Maximum Ratings* indicate limits beyond which damage to the device may occur. *Operating Ratings* indicate conditions for which the device is functional, but do not ensure specific performance limits. *Electrical Characteristics* state DC and AC electrical specifications under particular test conditions which ensure specific performance limits. This assumes that the device is within the Operating Ratings. Specifications are not ensured for parameters where no limit is given, however, the typical value is a good indication of device performance.

Electrical Characteristics⁽¹⁾⁽²⁾

The following specifications apply for $A_V = 2V/V$ ($R_I = 150k\Omega$), $R_L = 15\mu H + 8\Omega + 15\mu H$ unless otherwise specified. Limits apply for $T_A = 25^\circ C$.

Symbol	Parameter	Conditions	LM4675		Units (Limits)
			Typical ⁽³⁾	Limit ⁽⁴⁾⁽⁵⁾	
$ V_{OS} $	Differential Output Offset Voltage	$V_I = 0V, A_V = 2V/V, V_{DD} = 2.4V$ to $5.0V$	3		mV
$ I_{IH} $	Logic High Input Current	$V_{DD} = 5.0V, V_I = 5.5V$	17	100	μA (max)
$ I_{IL} $	Logic Low Input Current	$V_{DD} = 5.0V, V_I = -0.3V$	0.9	5	μA (max)
I_{DD}	Quiescent Power Supply Current	$V_{IN} = 0V$, No Load, $V_{DD} = 5.0V$	2.8	3.9	mA (max)
		$V_{IN} = 0V$, No Load, $V_{DD} = 3.6V$	2.2	2.9	mA
		$V_{IN} = 0V$, No Load, $V_{DD} = 2.4V$	1.6	2.3	mA (max)
		$V_{IN} = 0V, R_L = 8\Omega, V_{DD} = 5.0V$	2.8		
		$V_{IN} = 0V, R_L = 8\Omega, V_{DD} = 3.6V$	2.2		
		$V_{IN} = 0V, R_L = 8\Omega, V_{DD} = 2.4V$	1.6		
I_{SD}	Shutdown Current ⁽⁶⁾	$V_{SHUTDOWN} = 0V, V_{DD} = 2.4V$ to $5.0V$	0.01	1.0	μA (max)
V_{SDIH}	Shutdown voltage input high			1.4	V (min)
V_{SDIL}	Shutdown voltage input low			0.4	V (max)
R_{OSD}	Output Impedance	$V_{SHUTDOWN} = 0.4V$	100		$k\Omega$
A_V	Gain		$300k\Omega/R_I$		V/V (min) V/V (max)
R_{SD}	Resistance from Shutdown Pin to GND		300		$k\Omega$
f_{SW}	Switching Frequency		$300\pm 30\%$		kHz
P_O	Output Power	$R_L = 15\mu H + 4\Omega + 15\mu H$ THD = 10% (max) $f = 1kHz, 22kHz$ BW	$V_{DD} = 5V$	2.7	W
			$V_{DD} = 3.6V$	1.3	W
			$V_{DD} = 2.5V$	560	mW
		$R_L = 15\mu H + 4\Omega + 15\mu H$ THD = 1% (max) $f = 1kHz, 22kHz$ BW	$V_{DD} = 5V$	2.2	W
			$V_{DD} = 3.6V$	1.08	W
			$V_{DD} = 2.5V$	450	mW
		$R_L = 15\mu H + 8\Omega + 15\mu H$ THD = 10% (max) $f = 1kHz, 22kHz$ BW	$V_{DD} = 5V$	1.6	W
			$V_{DD} = 3.6V$	820	mW
			$V_{DD} = 2.5V$	350	mW
		$R_L = 15\mu H + 8\Omega + 15\mu H$ THD = 1% (max) $f = 1kHz, 22kHz$ BW	$V_{DD} = 5V$	1.3	W
			$V_{DD} = 3.6V$	650	600 mW
			$V_{DD} = 2.5V$	290	mW
THD+N	Total Harmonic Distortion + Noise	$V_{DD} = 5V, P_O = 0.1W, f = 1kHz$	0.03		%
		$V_{DD} = 3.6V, P_O = 0.1W, f = 1kHz$	0.02		%
		$V_{DD} = 2.5V, P_O = 0.1W, f = 1kHz$	0.04		%

- (1) All voltages are measured with respect to the ground pin, unless otherwise specified.
- (2) *Absolute Maximum Ratings* indicate limits beyond which damage to the device may occur. *Operating Ratings* indicate conditions for which the device is functional, but do not ensure specific performance limits. *Electrical Characteristics* state DC and AC electrical specifications under particular test conditions which ensure specific performance limits. This assumes that the device is within the Operating Ratings. Specifications are not ensured for parameters where no limit is given, however, the typical value is a good indication of device performance.
- (3) Typical specifications are specified at $25^\circ C$ and represent the parametric norm.
- (4) Tested limits are specified to TI's AOQL (Average Outgoing Quality Level).
- (5) Datasheet min/max specification limits are ensured by design, test, or statistical analysis.
- (6) Shutdown current is measured in a normal room environment. Exposure to direct sunlight will increase I_{SD} by a maximum of $2\mu A$. The Shutdown pin should be driven as close as possible to GND for minimal shutdown current and to V_{DD} for the best THD performance in PLAY mode. See the [Application Information](#) section under [SHUTDOWN FUNCTION](#) for more information.

Electrical Characteristics⁽¹⁾⁽²⁾ (continued)

The following specifications apply for $A_V = 2V/V$ ($R_I = 150k\Omega$), $R_L = 15\mu H + 8\Omega + 15\mu H$ unless otherwise specified. Limits apply for $T_A = 25^\circ C$.

Symbol	Parameter	Conditions	LM4675		Units (Limits)
			Typical ⁽³⁾	Limit ⁽⁴⁾⁽⁵⁾	
PSRR	Power Supply Rejection Ratio (Input Referred)	$V_{Ripple} = 200mV_{PP}$ Sine, $f_{Ripple} = 217Hz$, $V_{DD} = 3.6, 5V$ Inputs to AC GND, $C_I = 2\mu F$	82		dB
		$V_{Ripple} = 200mV_{PP}$ Sine, $f_{Ripple} = 1kHz$, $V_{DD} = 3.6, 5V$ Inputs to AC GND, $C_I = 2\mu F$	80		dB
SNR	Signal to Noise Ratio	$V_{DD} = 5V$, $P_O = 1W_{RMS}$	97		dB
ϵ_{OUT}	Output Noise (Input Referred)	$V_{DD} = 3.6V$, $f = 20Hz - 20kHz$ Inputs to AC GND, $C_I = 2\mu F$ No Weighting	28		μV_{RMS}
		$V_{DD} = 3.6V$, Inputs to AC GND $C_I = 2\mu F$, A Weighted	22		μV_{RMS}
CMRR	Common Mode Rejection Ratio (Input Referred)	$V_{DD} = 3.6V$, $V_{Ripple} = 1V_{PP}$ Sine $f_{Ripple} = 217Hz$	80		dB
T_{WU}	Wake-up Time	$V_{DD} = 3.6V$	17		μs
T_{SD}	Shutdown Time		140		μs
η	Efficiency	$V_{DD} = 3.6V$, $P_{OUT} = 400mW$ $R_L = 8\Omega$	89		%
		$V_{DD} = 5V$, $P_{OUT} = 1W$ $R_L = 8\Omega$	89		%

External Components Description

(Figure 2)

Components		Functional Description
1.	C_S	Supply bypass capacitor which provides power supply filtering. Refer to the POWER SUPPLY BYPASSING section for information concerning proper placement and selection of the supply bypass capacitor.
2.	C_I	Input AC coupling capacitor which blocks the DC voltage at the amplifier's input terminals.

Typical Performance Characteristics

The performance graphs were taken using the Audio Precision AUX-0025 Switching Amplifier measurement Filter in series with the LC filter on the demo board.

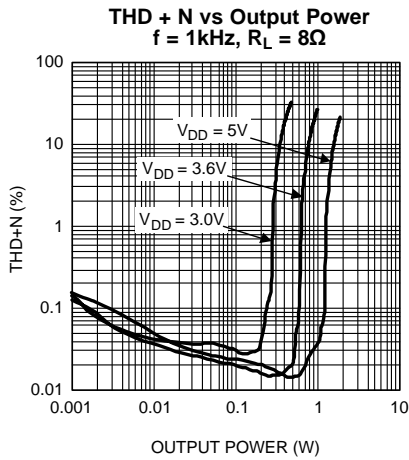

Figure 5.

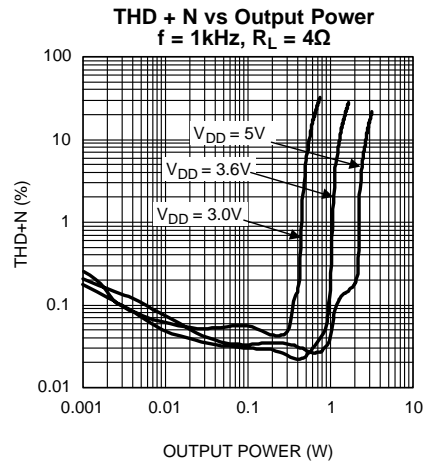

Figure 6.

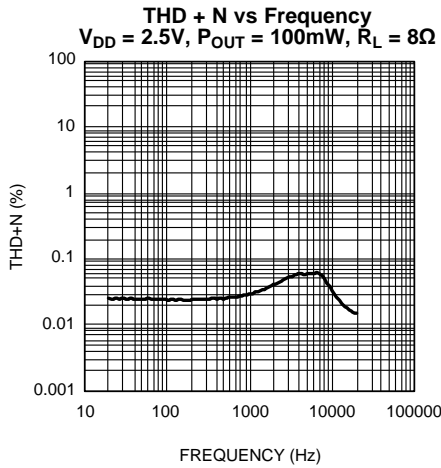

Figure 7.

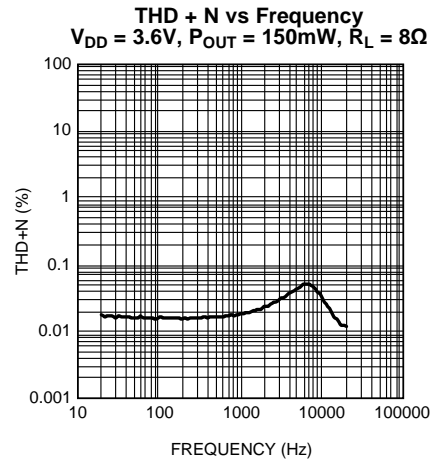

Figure 8.

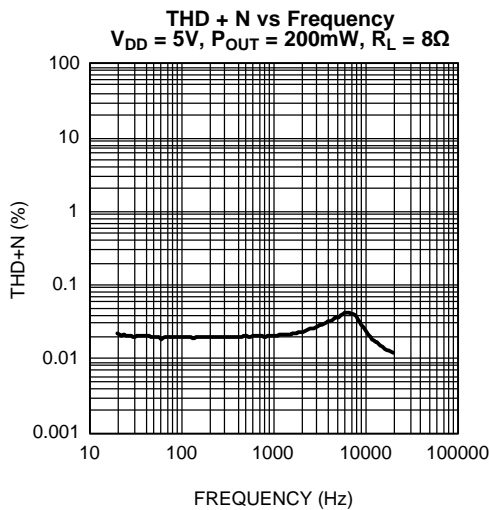

Figure 9.

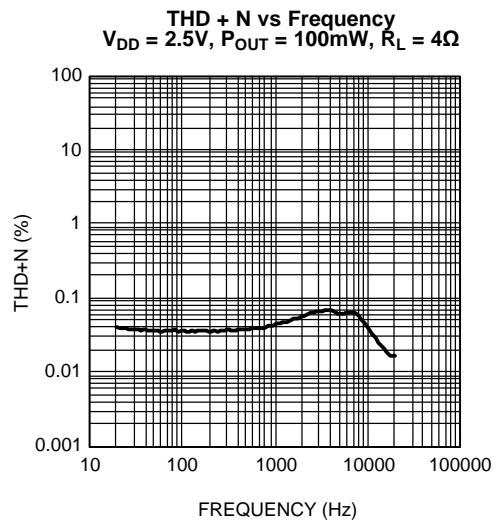

Figure 10.

Typical Performance Characteristics (continued)

The performance graphs were taken using the Audio Precision AUX-0025 Switching Amplifier measurement Filter in series with the LC filter on the demo board.

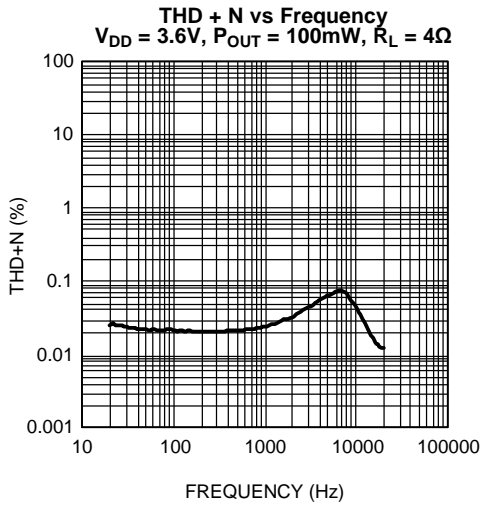

Figure 11.

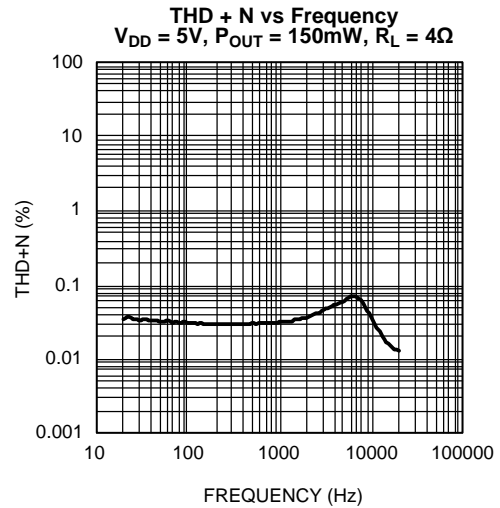

Figure 12.

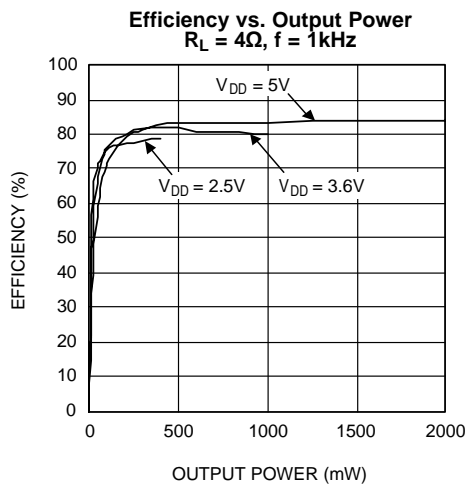

Figure 13.

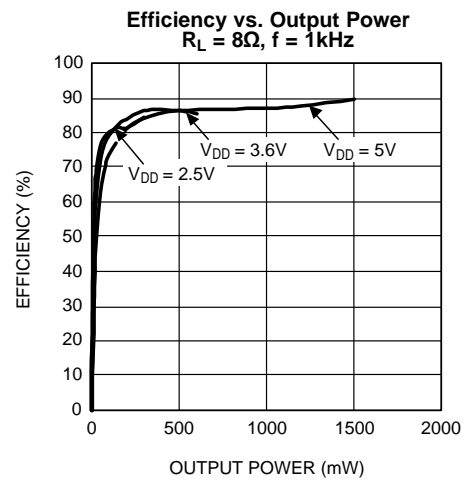

Figure 14.

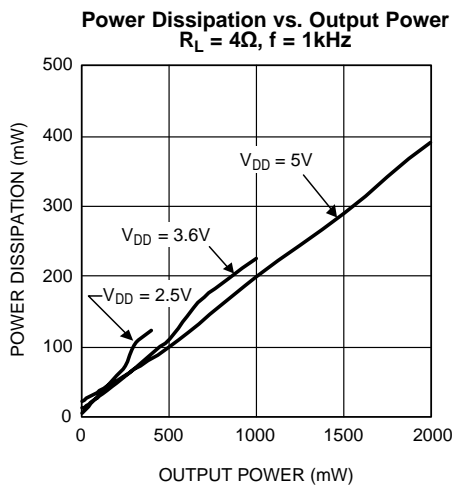

Figure 15.

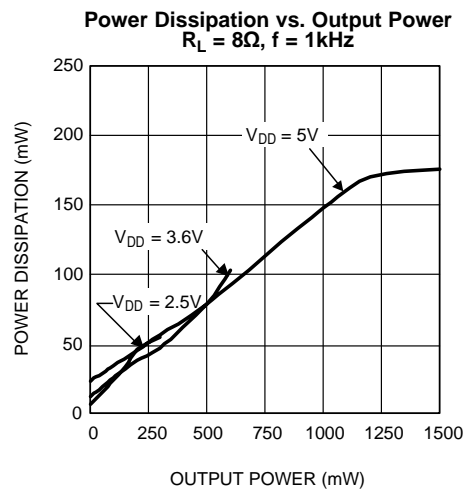

Figure 16.

Typical Performance Characteristics (continued)

The performance graphs were taken using the Audio Precision AUX-0025 Switching Amplifier measurement Filter in series with the LC filter on the demo board.

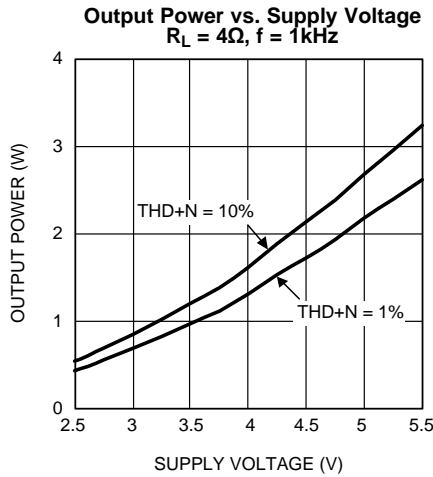

Figure 17.

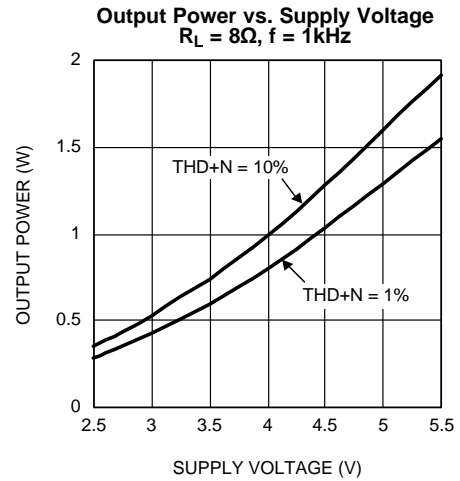

Figure 18.

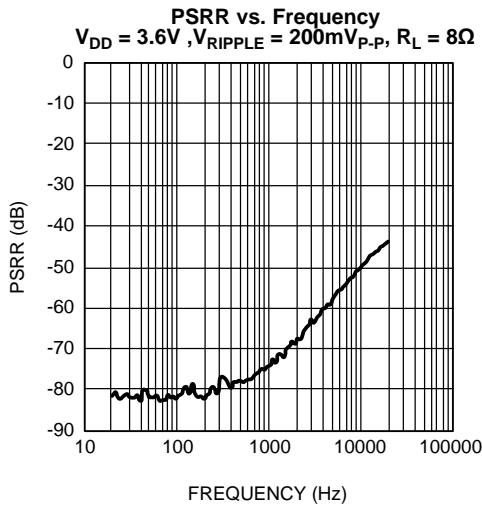

Figure 19.

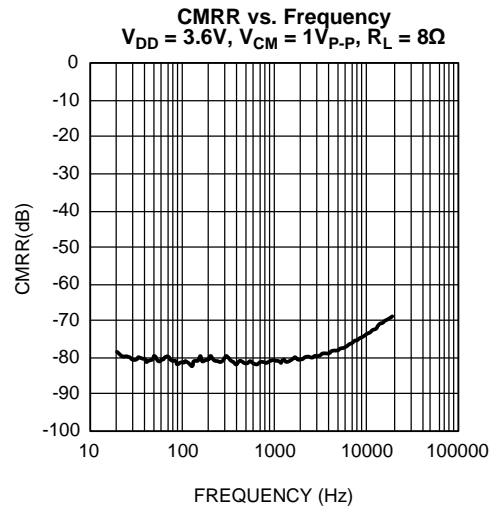

Figure 20.

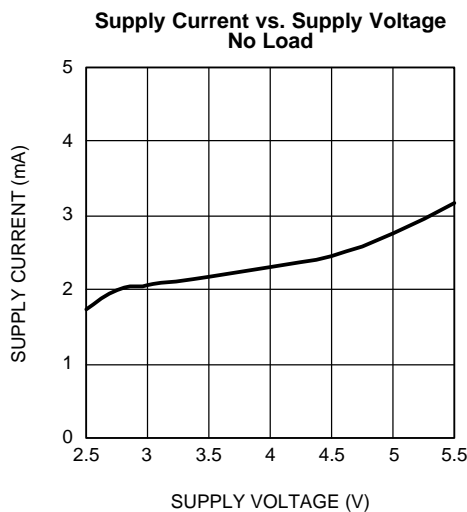

Figure 21.

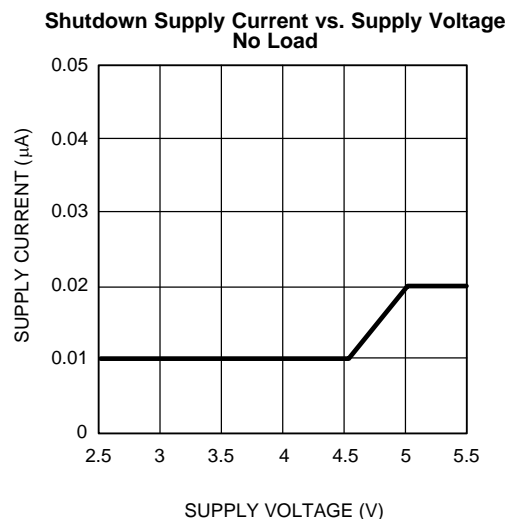
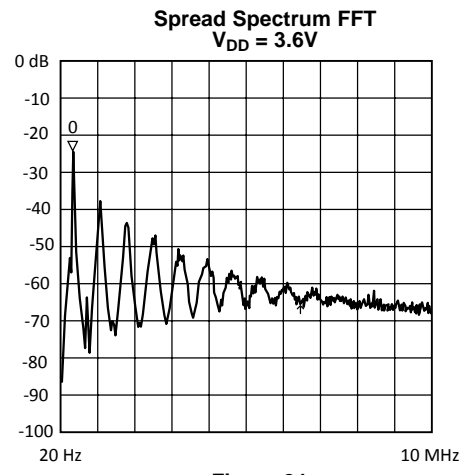
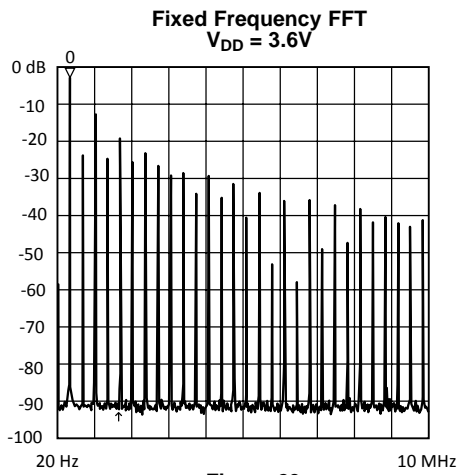

Figure 22.

Typical Performance Characteristics (continued)

The performance graphs were taken using the Audio Precision AUX-0025 Switching Amplifier measurement Filter in series with the LC filter on the demo board.



APPLICATION INFORMATION

GENERAL AMPLIFIER FUNCTION

The LM4675 features a filterless modulation scheme. The differential outputs of the device switch at 300kHz from V_{DD} to GND. When there is no input signal applied, the two outputs (V_{O1} and V_{O2}) switch with a 50% duty cycle, with both outputs in phase. Because the outputs of the LM4675 are differential, the two signals cancel each other. This results in no net voltage across the speaker, thus there is no load current during an idle state, conserving power.

With an input signal applied, the duty cycle (pulse width) of the LM4675 outputs changes. For increasing output voltages, the duty cycle of V_{O1} increases, while the duty cycle of V_{O2} decreases. For decreasing output voltages, the converse occurs, the duty cycle of V_{O2} increases while the duty cycle of V_{O1} decreases. The difference between the two pulse widths yields the differential output voltage.

SPREAD SPECTRUM MODULATION

The LM4675 features a filterless spread spectrum modulation scheme that eliminates the need for output filters, ferrite beads or chokes. The switching frequency varies by $\pm 30\%$ about a 300kHz center frequency, reducing the wideband spectral content, improving EMI emissions radiated by the speaker and associated cables and traces. Where a fixed frequency class D exhibits large amounts of spectral energy at multiples of the switching frequency, the spread spectrum architecture of the LM4675 spreads that energy over a larger bandwidth. The cycle-to-cycle variation of the switching period does not affect the audio reproduction of efficiency.

POWER DISSIPATION AND EFFICIENCY

In general terms, efficiency is considered to be the ratio of useful work output divided by the total energy required to produce it with the difference being the power dissipated, typically, in the IC. The key here is "useful" work. For audio systems, the energy delivered in the audible bands is considered useful including the distortion products of the input signal. Sub-sonic (DC) and super-sonic components ($>22\text{kHz}$) are not useful. The difference between the power flowing from the power supply and the audio band power being transduced is dissipated in the LM4675 and in the transducer load. The amount of power dissipation in the LM4675 is very low. This is because the ON resistance of the switches used to form the output waveforms is typically less than 0.25Ω . This leaves only the transducer load as a potential "sink" for the small excess of input power over audio band output power. The LM4675 dissipates only a fraction of the excess power requiring no additional PCB area or copper plane to act as a heat sink.

DIFFERENTIAL AMPLIFIER EXPLANATION

As logic supply voltages continue to shrink, designers are increasingly turning to differential analog signal handling to preserve signal to noise ratios with restricted voltage swing. The LM4675 is a fully differential amplifier that features differential input and output stages. A differential amplifier amplifies the difference between the two input signals. Traditional audio power amplifiers have typically offered only single-ended inputs resulting in a 6dB reduction in signal to noise ratio relative to differential inputs. The LM4675 also offers the possibility of DC input coupling which eliminates the two external AC coupling, DC blocking capacitors. The LM4675 can be used, however, as a single ended input amplifier while still retaining its fully differential benefits. In fact, completely unrelated signals may be placed on the input pins. The LM4675 simply amplifies the difference between the signals. A major benefit of a differential amplifier is the improved common mode rejection ratio (CMRR) over single input amplifiers. The common-mode rejection characteristic of the differential amplifier reduces sensitivity to ground offset related noise injection, especially important in high noise applications.

PCB LAYOUT CONSIDERATIONS

As output power increases, interconnect resistance (PCB traces and wires) between the amplifier, load and power supply create a voltage drop. The voltage loss on the traces between the LM4675 and the load results in lower output power and decreased efficiency. Higher trace resistance between the supply and the LM4675 has the same effect as a poorly regulated supply, increased ripple on the supply line also reducing the peak output power. The effects of residual trace resistance increases as output current increases due to higher output power, decreased load impedance or both. To maintain the highest output voltage swing and corresponding peak output power, the PCB traces that connect the output pins to the load and the supply pins to the power supply should be as wide as possible to minimize trace resistance.

The use of power and ground planes will give the best THD+N performance. While reducing trace resistance, the use of power planes also creates parasite capacitors that help to filter the power supply line.

The inductive nature of the transducer load can also result in overshoot on one or both edges, clamped by the parasitic diodes to GND and V_{DD} in each case. From an EMI standpoint, this is an aggressive waveform that can radiate or conduct to other components in the system and cause interference. It is essential to keep the power and output traces short and well shielded if possible. Use of ground planes, beads, and micro-strip layout techniques are all useful in preventing unwanted interference.

As the distance from the LM4675 and the speaker increase, the amount of EMI radiation will increase since the output wires or traces acting as antenna become more efficient with length. What is acceptable EMI is highly application specific. Ferrite chip inductors placed close to the LM4675 may be needed to reduce EMI radiation. The value of the ferrite chip is very application specific.

POWER SUPPLY BYPASSING

As with any power amplifier, proper supply bypassing is critical for low noise performance and high power supply rejection ratio (PSRR). The capacitor (C_S) location should be as close as possible to the LM4675. Typical applications employ a voltage regulator with a 10 μ F and a 0.1 μ F bypass capacitors that increase supply stability. These capacitors do not eliminate the need for bypassing on the supply pin of the LM4675. A 4.7 μ F tantalum capacitor is recommended.

SHUTDOWN FUNCTION

In order to reduce power consumption while not in use, the LM4675 contains shutdown circuitry that reduces current draw to less than 0.01 μ A. The trigger point for shutdown is shown as a typical value in the Electrical Characteristics Tables and in the Shutdown Hysteresis Voltage graphs found in the [Typical Performance Characteristics](#) section. It is best to switch between ground and supply for minimum current usage while in the shutdown state. While the LM4675 may be disabled with shutdown voltages in between ground and supply, the idle current will be greater than the typical 0.01 μ A value.

The LM4675 has an internal resistor connected between GND and Shutdown pins. The purpose of this resistor is to eliminate any unwanted state changes when the Shutdown pin is floating. The LM4675 will enter the shutdown state when the Shutdown pin is left floating or if not floating, when the shutdown voltage has crossed the threshold. To minimize the supply current while in the shutdown state, the Shutdown pin should be driven to GND or left floating. If the Shutdown pin is not driven to GND, the amount of additional resistor current due to the internal shutdown resistor can be found by [Equation 1](#) below.

$$(V_{SD} - GND) / 300k\Omega \quad (1)$$

With only a 0.5V difference, an additional 1.7 μ A of current will be drawn while in the shutdown state.

PROPER SELECTION OF EXTERNAL COMPONENTS

The gain of the LM4675 is set by the external resistors, R_i in [Figure 2](#), The Gain is given by [Equation 2](#) below. Best THD+N performance is achieved with a gain of 2V/V (6dB).

$$A_V = 2 * 150 k\Omega / R_i \quad (V/V) \quad (2)$$

It is recommended that resistors with 1% tolerance or better be used to set the gain of the LM4675. The R_i resistors should be placed close to the input pins of the LM4675. Keeping the input traces close to each other and of the same length in a high noise environment will aid in noise rejection due to the good CMRR of the LM4675. Noise coupled onto input traces which are physically close to each other will be common mode and easily rejected by the LM4675.

Input capacitors may be needed for some applications or when the source is single-ended (see [Figure 26](#), [Figure 28](#)). Input capacitors are needed to block any DC voltage at the source so that the DC voltage seen between the input terminals of the LM4675 is 0V. Input capacitors create a high-pass filter with the input resistors, R_i . The -3dB point of the high-pass filter is found using [Equation 3](#) below.

$$f_C = 1 / (2\pi R_i C_i) \quad (\text{Hz}) \quad (3)$$

The input capacitors may also be used to remove low audio frequencies. Small speakers cannot reproduce low bass frequencies so filtering may be desired. When the LM4675 is using a single-ended source, power supply noise on the ground is seen as an input signal by the +IN input pin that is capacitor coupled to ground (See Figure 28 – Figure 30). Setting the high-pass filter point above the power supply noise frequencies, 217Hz in a GSM phone, for example, will filter out this noise so it is not amplified and heard on the output. Capacitors with a tolerance of 10% or better are recommended for impedance matching.

DIFFERENTIAL CIRCUIT CONFIGURATIONS

The LM4675 can be used in many different circuit configurations. The simplest and best performing is the DC coupled, differential input configuration shown in Figure 25. Equation 2 above is used to determine the value of the R_i resistors for a desired gain.

Input capacitors can be used in a differential configuration as shown in Figure 26. Equation 3 above is used to determine the value of the C_i capacitors for a desired frequency response due to the high-pass filter created by C_i and R_i . Equation 2 above is used to determine the value of the R_i resistors for a desired gain.

The LM4675 can be used to amplify more than one audio source. Figure 27 shows a dual differential input configuration. The gain for each input can be independently set for maximum design flexibility using the R_i resistors for each input and Equation 2. Input capacitors can be used with one or more sources as well to have different frequency responses depending on the source or if a DC voltage needs to be blocked from a source.

SINGLE-ENDED CIRCUIT CONFIGURATIONS

The LM4675 can also be used with single-ended sources but input capacitors will be needed to block any DC at the input terminals. Figure 28 shows the typical single-ended application configuration. The equations for Gain, Equation 2, and frequency response, Equation 3, hold for the single-ended configuration as shown in Figure 28.

When using more than one single-ended source as shown in Figure 29, the impedance seen from each input terminal should be equal. To find the correct values for C_{i3} and R_{i3} connected to the +IN input pin the equivalent impedance of all the single-ended sources are calculated. The single-ended sources are in parallel to each other. The equivalent capacitor and resistor, C_{i3} and R_{i3} , are found by calculating the parallel combination of all C_i values and then all R_i values. Equation 4 and Equation 5 below are for any number of single-ended sources.

$$C_{i3} = C_{i1} + C_{i2} + C_{in} \quad (F) \tag{4}$$

$$R_{i3} = 1 / (1/R_{i1} + 1/R_{i2} + 1/R_{in}) \quad (\Omega) \tag{5}$$

The LM4675 may also use a combination of single-ended and differential sources. A typical application with one single-ended source and one differential source is shown in Figure 30. Using the principle of superposition, the external component values can be determined with the above equations corresponding to the configuration.

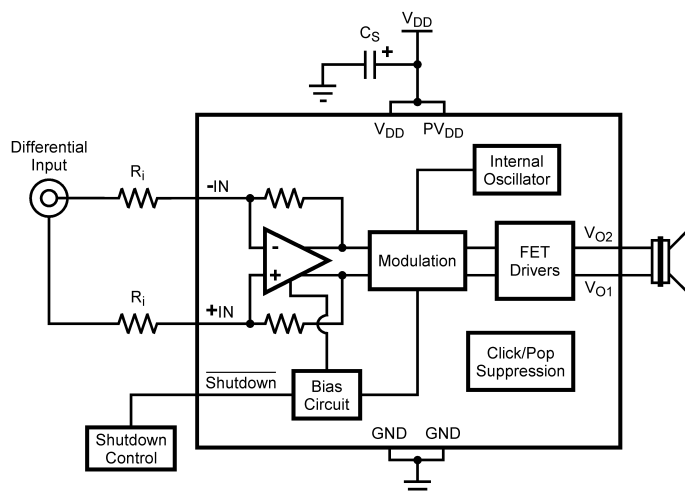

Figure 25. Differential Input Configuration

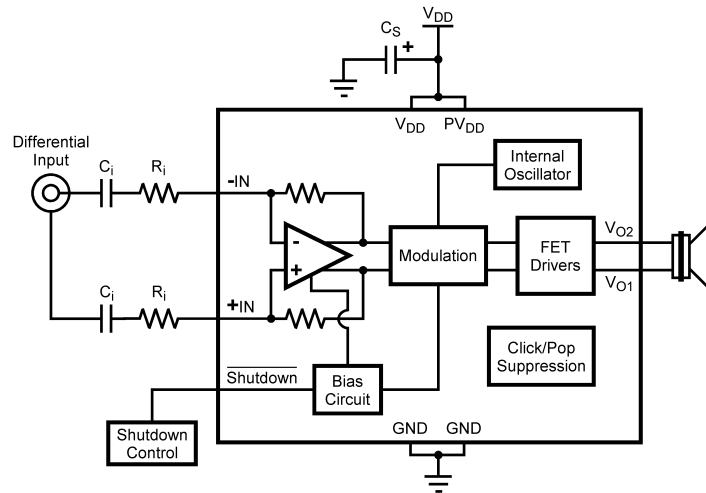

Figure 26. Differential Input Configuration with Input Capacitors

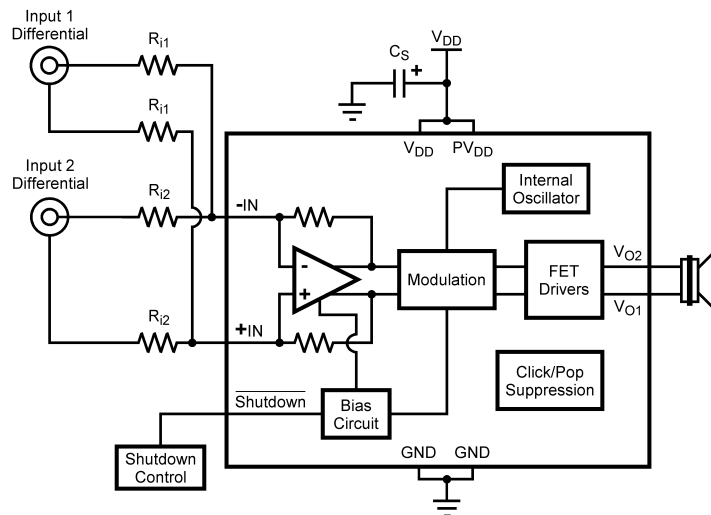

Figure 27. Dual Differential Input Configuration

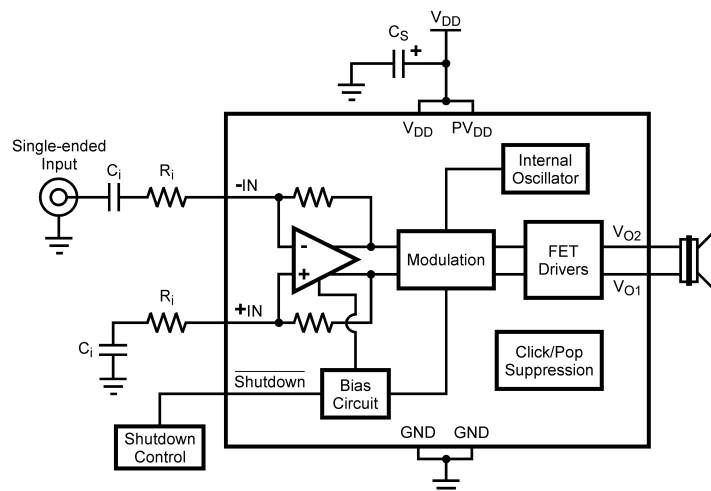

Figure 28. Single-Ended Input Configuration

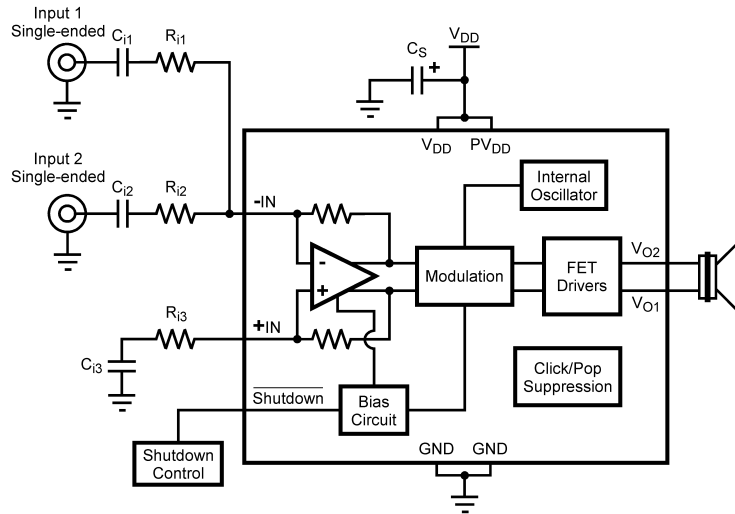

Figure 29. Dual Single-Ended Input Configuration

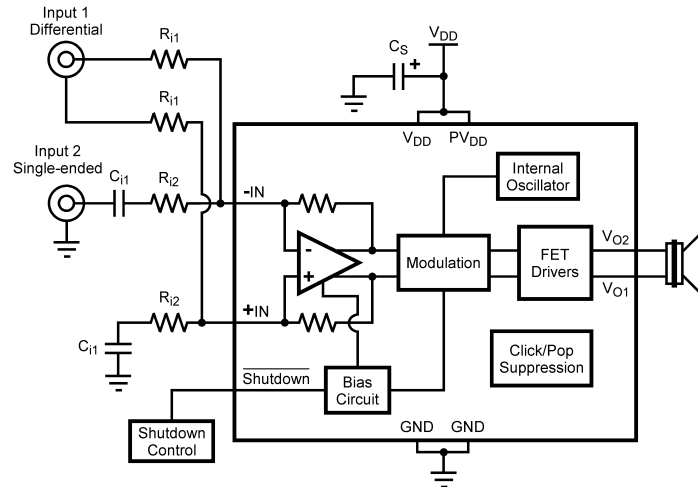
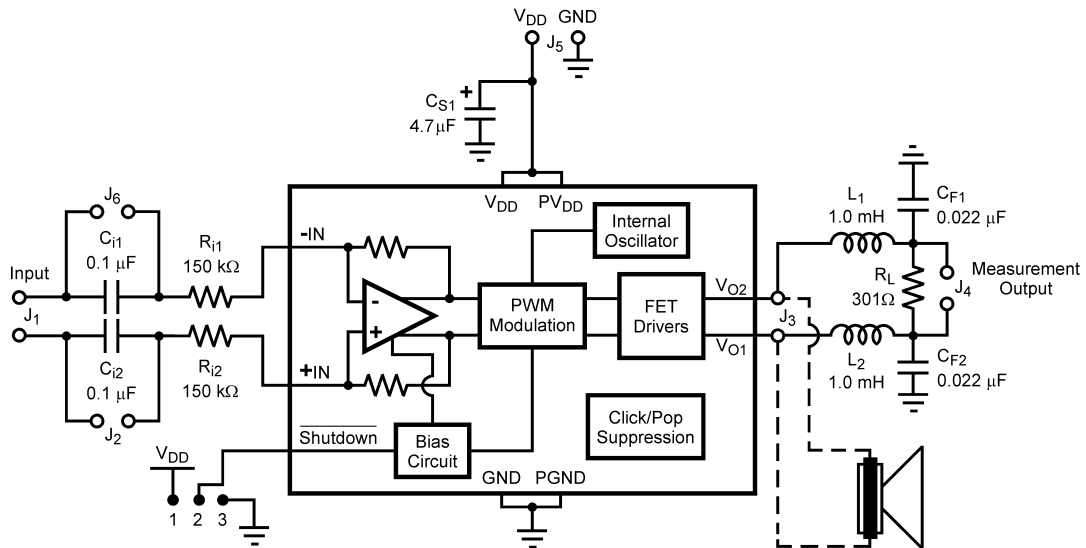

Figure 30. Dual Input with a Single-Ended Input and a Differential Input

REFERENCE DESIGN BOARD SCHEMATIC

In addition to the minimal parts required for the application circuit, a measurement filter is provided on the evaluation circuit board so that conventional audio measurements can be conveniently made without additional equipment. This is a balanced input, grounded differential output low pass filter with a 3dB frequency of approximately 35kHz and an on board termination resistor of 300Ω (see [schematic](#)). Note that the capacitive load elements are returned to ground. This is not optimal for common mode rejection purposes, but due to the independent pulse format at each output there is a significant amount of high frequency common mode component on the outputs. The grounded capacitive filter elements attenuate this component at the board to reduce the high frequency CMRR requirement placed on the analysis instruments.

Even with the grounded filter the audio signal is still differential, necessitating a differential input on any analysis instrument connected to it. Most lab instruments that feature BNC connectors on their inputs are **NOT** differential responding because the ring of the BNC is usually grounded.

The commonly used Audio Precision analyzer is differential, but its ability to accurately reject high frequency signals is questionable necessitating the on board measurement filter. When in doubt or when the signal needs to be single-ended, use an audio signal transformer to convert the differential output to a single ended output. Depending on the audio transformer's characteristics, there may be some attenuation of the audio signal which needs to be taken into account for correct measurement of performance.

Measurements made at the output of the measurement filter suffer attenuation relative to the primary, unfiltered outputs even at audio frequencies. This is due to the resistance of the inductors interacting with the termination resistor (300Ω) and is typically about -0.25dB (3%). In other words, the voltage levels (and corresponding power levels) indicated through the measurement filter are slightly lower than those that actually occur at the load placed on the unfiltered outputs. This small loss in the filter for measurement gives a lower output power reading than what is really occurring on the unfiltered outputs and its load.

REVISION HISTORY

Rev	Date	Description
1.0	08/16/06	Initial release.
1.1	09/01/06	Added the DSBGA (YZR009) package.
1.2	10/12/06	Text edit (X-axis label) on Rf Emissions on page 1.
1.3	07/02/08	Text edits.

Changes from Revision B (May 2013) to Revision C

Page

- Changed layout of National Data Sheet to TI format [15](#)

PACKAGING INFORMATION

Orderable Device	Status (1)	Package Type	Package Drawing	Pins	Package Qty	Eco Plan (2)	Lead finish/ Ball material (6)	MSL Peak Temp (3)	Op Temp (°C)	Device Marking (4/5)	Samples
LM4675SD/NOPB	ACTIVE	WSON	NGQ	8	1000	RoHS & Green	SN	Level-1-260C-UNLIM		L4675	Samples
LM4675SDX/NOPB	ACTIVE	WSON	NGQ	8	4500	RoHS & Green	SN	Level-1-260C-UNLIM		L4675	Samples
LM4675TL/NOPB	ACTIVE	DSBGA	YZR	9	250	RoHS & Green	SNAGCU	Level-1-260C-UNLIM	-40 to 85	G H8	Samples
LM4675TLX/NOPB	ACTIVE	DSBGA	YZR	9	3000	RoHS & Green	SNAGCU	Level-1-260C-UNLIM	-40 to 85	G H8	Samples

(1) The marketing status values are defined as follows:

ACTIVE: Product device recommended for new designs.

LIFEBUY: TI has announced that the device will be discontinued, and a lifetime-buy period is in effect.

NRND: Not recommended for new designs. Device is in production to support existing customers, but TI does not recommend using this part in a new design.

PREVIEW: Device has been announced but is not in production. Samples may or may not be available.

OBSOLETE: TI has discontinued the production of the device.

(2) **RoHS:** TI defines "RoHS" to mean semiconductor products that are compliant with the current EU RoHS requirements for all 10 RoHS substances, including the requirement that RoHS substance do not exceed 0.1% by weight in homogeneous materials. Where designed to be soldered at high temperatures, "RoHS" products are suitable for use in specified lead-free processes. TI may reference these types of products as "Pb-Free".

RoHS Exempt: TI defines "RoHS Exempt" to mean products that contain lead but are compliant with EU RoHS pursuant to a specific EU RoHS exemption.

Green: TI defines "Green" to mean the content of Chlorine (Cl) and Bromine (Br) based flame retardants meet JS709B low halogen requirements of <=1000ppm threshold. Antimony trioxide based flame retardants must also meet the <=1000ppm threshold requirement.

(3) MSL, Peak Temp. - The Moisture Sensitivity Level rating according to the JEDEC industry standard classifications, and peak solder temperature.

(4) There may be additional marking, which relates to the logo, the lot trace code information, or the environmental category on the device.

(5) Multiple Device Markings will be inside parentheses. Only one Device Marking contained in parentheses and separated by a "~" will appear on a device. If a line is indented then it is a continuation of the previous line and the two combined represent the entire Device Marking for that device.

(6) Lead finish/Ball material - Orderable Devices may have multiple material finish options. Finish options are separated by a vertical ruled line. Lead finish/Ball material values may wrap to two lines if the finish value exceeds the maximum column width.

Important Information and Disclaimer:The information provided on this page represents TI's knowledge and belief as of the date that it is provided. TI bases its knowledge and belief on information provided by third parties, and makes no representation or warranty as to the accuracy of such information. Efforts are underway to better integrate information from third parties. TI has taken and

continues to take reasonable steps to provide representative and accurate information but may not have conducted destructive testing or chemical analysis on incoming materials and chemicals. TI and TI suppliers consider certain information to be proprietary, and thus CAS numbers and other limited information may not be available for release.

In no event shall TI's liability arising out of such information exceed the total purchase price of the TI part(s) at issue in this document sold by TI to Customer on an annual basis.

TAPE AND REEL INFORMATION

QUADRANT ASSIGNMENTS FOR PIN 1 ORIENTATION IN TAPE



*All dimensions are nominal

Device	Package Type	Package Drawing	Pins	SPQ	Reel Diameter (mm)	Reel Width W1 (mm)	A0 (mm)	B0 (mm)	K0 (mm)	P1 (mm)	W (mm)	Pin1 Quadrant
LM4675SD/NOPB	WSON	NGQ	8	1000	178.0	12.4	3.3	3.3	1.0	8.0	12.0	Q1
LM4675SDX/NOPB	WSON	NGQ	8	4500	330.0	12.4	3.3	3.3	1.0	8.0	12.0	Q1
LM4675TL/NOPB	DSBGA	YZR	9	250	178.0	8.4	1.7	1.7	0.76	4.0	8.0	Q1
LM4675TLX/NOPB	DSBGA	YZR	9	3000	178.0	8.4	1.7	1.7	0.76	4.0	8.0	Q1

TAPE AND REEL BOX DIMENSIONS

*All dimensions are nominal

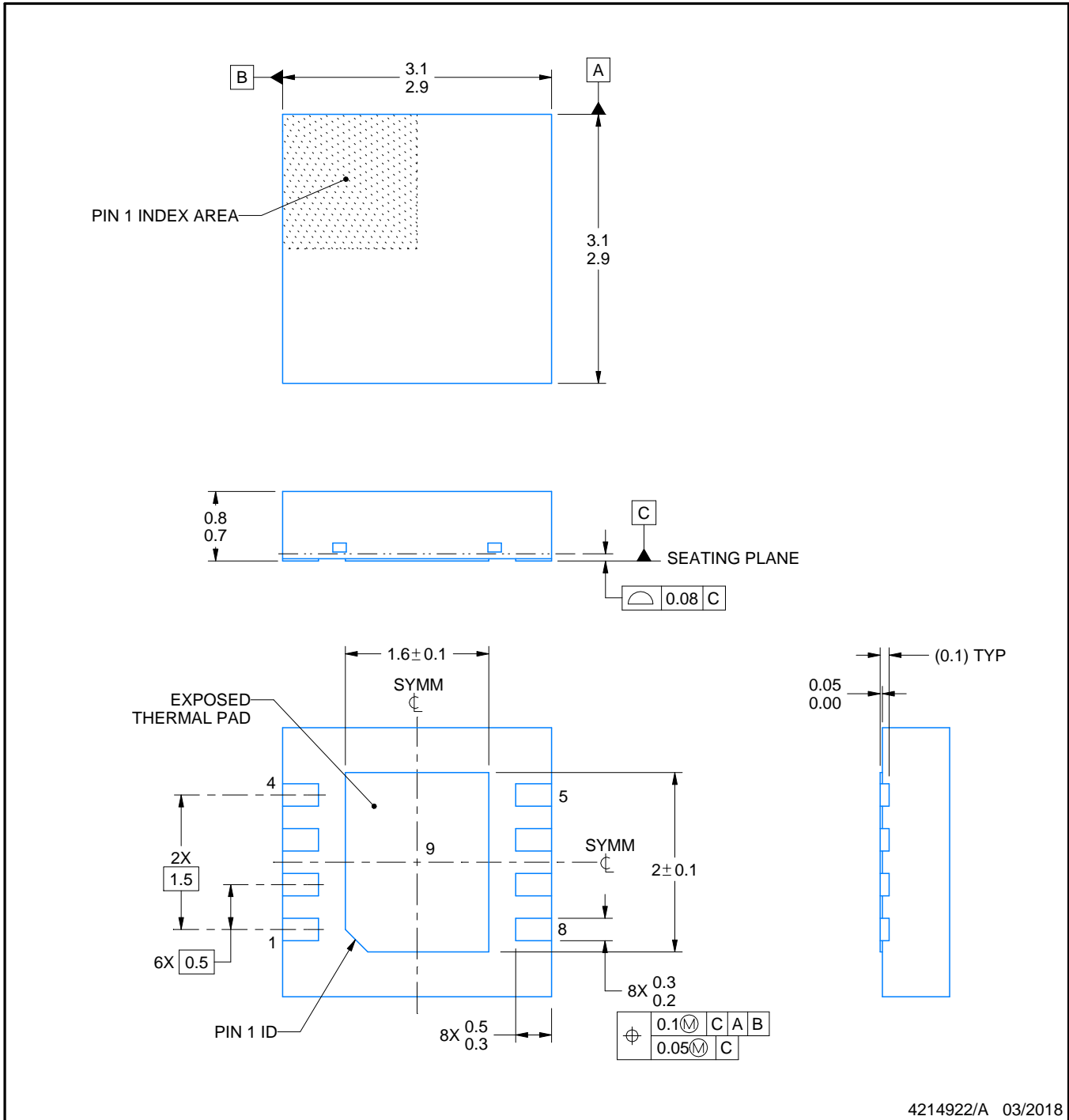
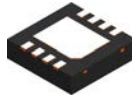
Device	Package Type	Package Drawing	Pins	SPQ	Length (mm)	Width (mm)	Height (mm)
LM4675SD/NOPB	WSON	NGQ	8	1000	208.0	191.0	35.0
LM4675SDX/NOPB	WSON	NGQ	8	4500	367.0	367.0	35.0
LM4675TL/NOPB	DSBGA	YZR	9	250	208.0	191.0	35.0
LM4675TLX/NOPB	DSBGA	YZR	9	3000	208.0	191.0	35.0



4214922/A 03/2018

NOTES:

1. All linear dimensions are in millimeters. Any dimensions in parenthesis are for reference only. Dimensioning and tolerancing per ASME Y14.5M.
2. This drawing is subject to change without notice.
3. The package thermal pad must be soldered to the printed circuit board for thermal and mechanical performance.

EXAMPLE BOARD LAYOUT

NGQ0008A

WSON - 0.8 mm max height

PLASTIC SMALL OUTLINE - NO LEAD

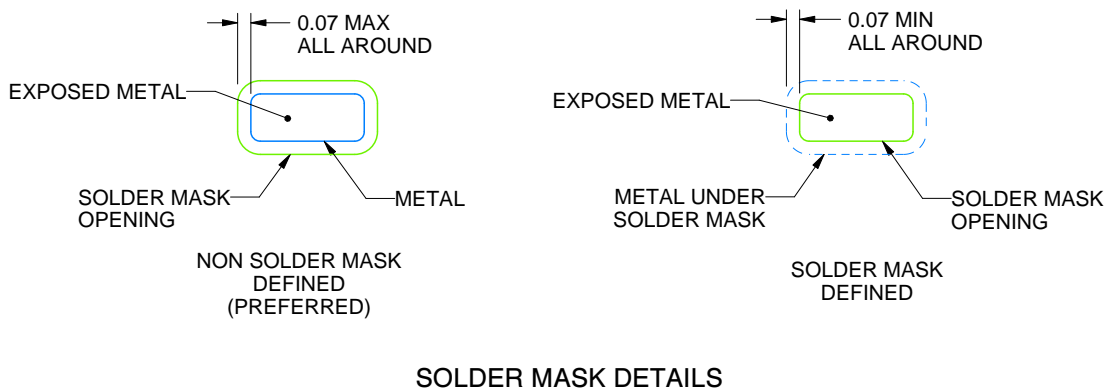
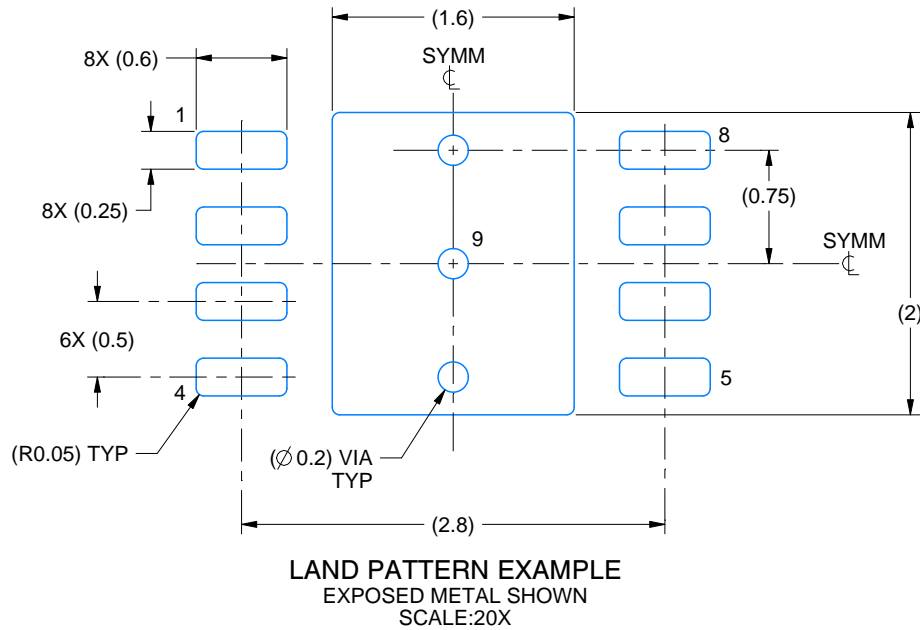

4214922/A 03/2018

NOTES: (continued)

4. This package is designed to be soldered to a thermal pad on the board. For more information, see Texas Instruments literature number SLUA271 (www.ti.com/lit/sluea271).
5. Vias are optional depending on application, refer to device data sheet. If any vias are implemented, refer to their locations shown on this view. It is recommended that vias under paste be filled, plugged or tented.

EXAMPLE STENCIL DESIGN

NGQ0008A

WSON - 0.8 mm max height

PLASTIC SMALL OUTLINE - NO LEAD

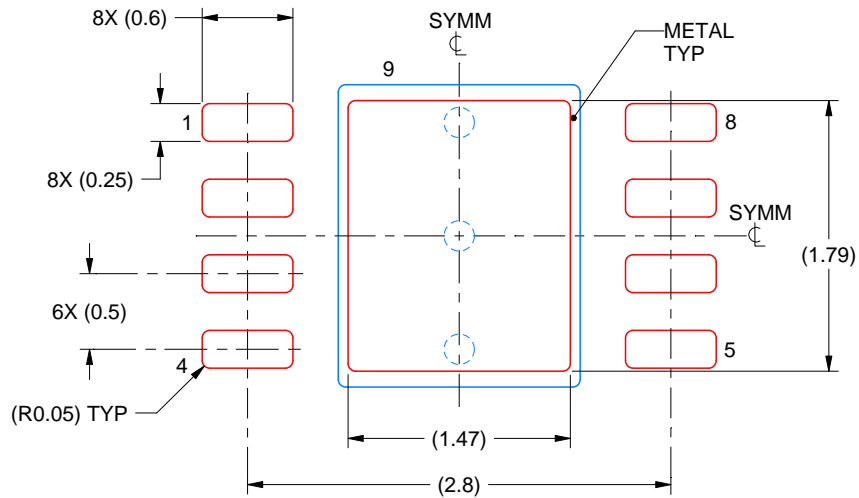

SOLDER PASTE EXAMPLE
BASED ON 0.1 mm THICK STENCIL

EXPOSED PAD 9:
82% PRINTED SOLDER COVERAGE BY AREA UNDER PACKAGE
SCALE:20X

4214922/A 03/2018

NOTES: (continued)

6. Laser cutting apertures with trapezoidal walls and rounded corners may offer better paste release. IPC-7525 may have alternate design recommendations.

YZR0009

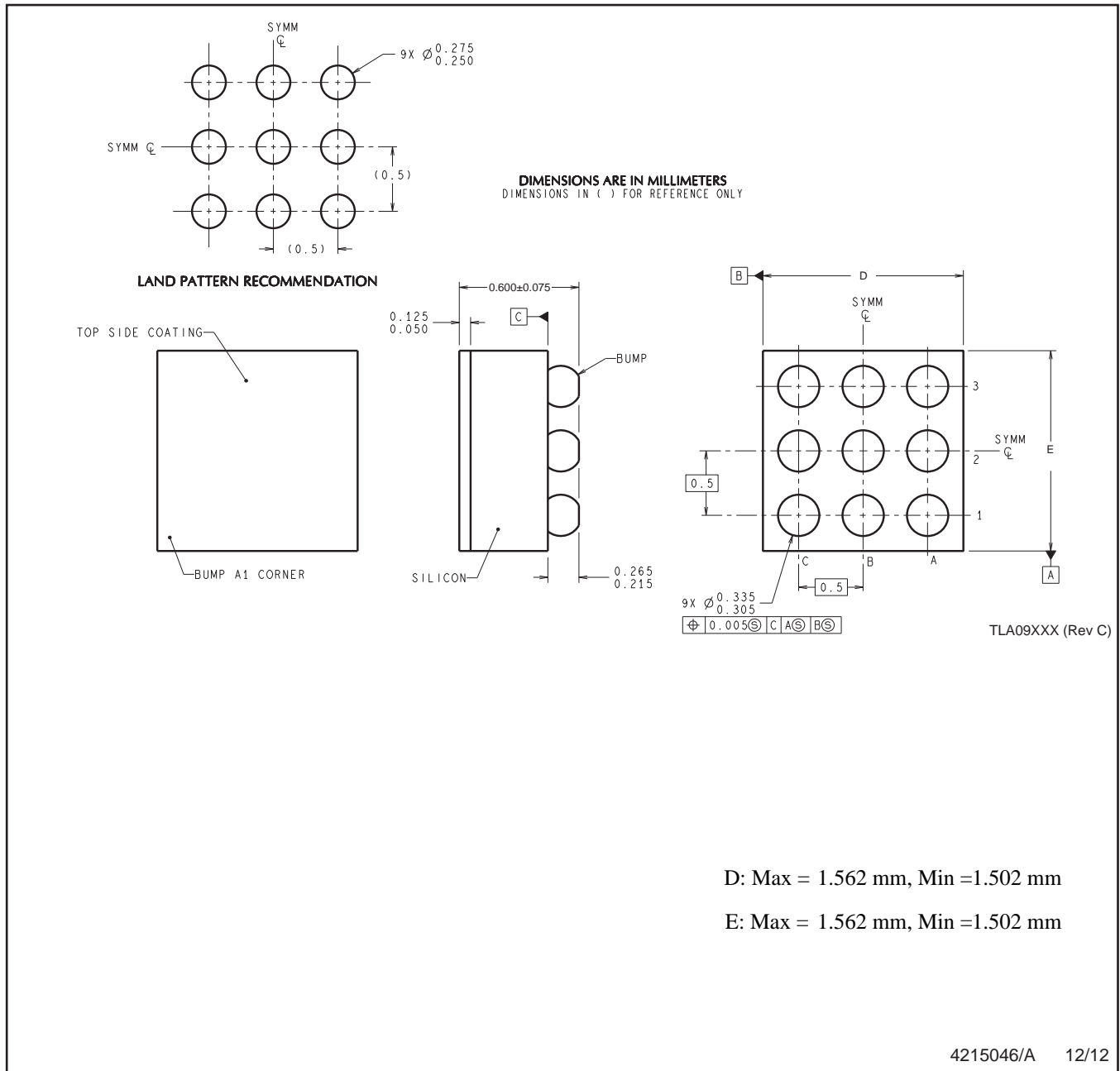

NOTES: A. All linear dimensions are in millimeters. Dimensioning and tolerancing per ASME Y14.5M-1994.
B. This drawing is subject to change without notice.

IMPORTANT NOTICE AND DISCLAIMER

TI PROVIDES TECHNICAL AND RELIABILITY DATA (INCLUDING DATA SHEETS), DESIGN RESOURCES (INCLUDING REFERENCE DESIGNS), APPLICATION OR OTHER DESIGN ADVICE, WEB TOOLS, SAFETY INFORMATION, AND OTHER RESOURCES "AS IS" AND WITH ALL FAULTS, AND DISCLAIMS ALL WARRANTIES, EXPRESS AND IMPLIED, INCLUDING WITHOUT LIMITATION ANY IMPLIED WARRANTIES OF MERCHANTABILITY, FITNESS FOR A PARTICULAR PURPOSE OR NON-INFRINGEMENT OF THIRD PARTY INTELLECTUAL PROPERTY RIGHTS.

These resources are intended for skilled developers designing with TI products. You are solely responsible for (1) selecting the appropriate TI products for your application, (2) designing, validating and testing your application, and (3) ensuring your application meets applicable standards, and any other safety, security, regulatory or other requirements.

These resources are subject to change without notice. TI grants you permission to use these resources only for development of an application that uses the TI products described in the resource. Other reproduction and display of these resources is prohibited. No license is granted to any other TI intellectual property right or to any third party intellectual property right. TI disclaims responsibility for, and you will fully indemnify TI and its representatives against, any claims, damages, costs, losses, and liabilities arising out of your use of these resources.

TI's products are provided subject to [TI's Terms of Sale](#) or other applicable terms available either on [ti.com](#) or provided in conjunction with such TI products. TI's provision of these resources does not expand or otherwise alter TI's applicable warranties or warranty disclaimers for TI products.

TI objects to and rejects any additional or different terms you may have proposed.

Mailing Address: Texas Instruments, Post Office Box 655303, Dallas, Texas 75265
Copyright © 2021, Texas Instruments Incorporated