

TS5A23157-Q1 双通道 15Ω SPDT 模拟开关

1 特性

- 符合汽车应用要求
- 具有符合 AEC-Q100 标准的下列特性：
 - 器件温度等级 1：-40°C 至 125°C
 - 器件 HBM ESD 分类等级 H2
 - 器件 CDM ESD 分类等级 C4B
- 提供功能安全
 - 可帮助进行功能安全系统设计的文档
- 可支持客户特殊配置控制与重大变更批准
- 指定的先断后合开关
- 低导通电阻 (15Ω)
- 控制输入可承受 5V 电压
- 低电荷注入
- 出色的导通电阻匹配
- 低总计谐波失真
- 1.8V 至 5.5V 单电源运行

2 应用

- 采样保持电路
- 电池供电类设备
- 音频和视频信号路由
- 通信电路

3 描述

TS5A23157-Q1 是一款双通道单极双投 (SPDT) 模拟开关，其设计工作电压为 1.65V 至 5.5V。该器件可以同时处理数字和模拟信号，并可在任一方向传输高达 5.5V (峰值) 的信号。

有关最新的封装和订购信息，请参阅本文档结尾的“封装选项附录”，或访问 TI 网站：www.ti.com。

表 3-1. 器件信息⁽¹⁾

器件型号	封装	封装尺寸 (标称值)
TS5A23157-Q1	VSSOP (10)	3.00mm × 3.00mm

(1) 如需了解所有可用封装，请参阅数据表末尾的封装选项附录。

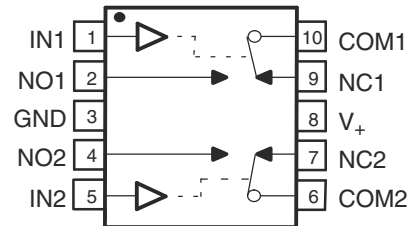

TS5A23157-Q1 功能框图



Table of Contents

1 特性	1	11 Application and Implementation	19
2 应用	1	11.1 Application Information.....	19
3 描述	1	11.2 Typical Application.....	19
4 Revision History	2	11.3 Design Requirements.....	19
5 Pin Configurations and Functions	3	11.4 Detailed Design Procedure.....	20
6 Specifications	4	11.5 Application Performance Plots.....	20
6.1 Absolute Maximum Ratings.....	4	12 Power Supply Recommendations	20
6.2 Electrical Characteristics for 5-V Supply.....	5	13 Layout	21
6.3 Electrical Characteristics for 3.3-V Supply.....	7	13.1 Layout Guidelines.....	21
6.4 Electrical Characteristics for 2.5-V Supply.....	9	13.2 Layout Example.....	22
6.5 Electrical Characteristics for 1.8-V Supply.....	10	14 Device and Documentation Support	23
6.6 Typical Characteristics.....	11	14.1 接收文档更新通知.....	23
7 Parameter Description	12	14.2 支持资源.....	23
8 Parameter Measurement Information	13	14.3 Trademarks.....	23
9 Function and Summary of Characteristics	17	14.4 Electrostatic Discharge Caution.....	23
10 Detailed Description	18	14.5 Glossary.....	23
10.1 Overview.....	18	15 Mechanical, Packaging, and Orderable Information	23
10.2 Functional Block Diagram.....	18	15.1 Ordering Information.....	23
10.3 Feature Description.....	18		
10.4 Device Functional Modes.....	18		

4 Revision History

注：以前版本的页码可能与当前版本的页码不同

Changes from Revision A (February 2013) to Revision B (June 2021)	Page
• 更新了整个文档中的表格、图和交叉参考的编号格式.....	1
• 向 <i>特性</i> 部分添加了“提供功能安全”信息.....	1

5 Pin Configurations and Functions



图 5-1. DGS VSSOP (16) Top View

表 5-1. Pin Functions

PIN		Type	DESCRIPTION
NAME	NO.		
COM1	10	I/O	Common
COM2	6	I/O	Common
GND	3	P	Ground
IN1	1	I	Digital control to connect COM to NO or NC
IN2	5	I	Digital control to connect COM to NO or NC
NC1	9	I/O	Normally closed
NC2	7	I/O	Normally closed
NO1	2	I/O	Normally open
NO2	4	I/O	Normally open
V ₊	8	P	Power supply

1. I = input, O = output, I/O = input and output, P = power.

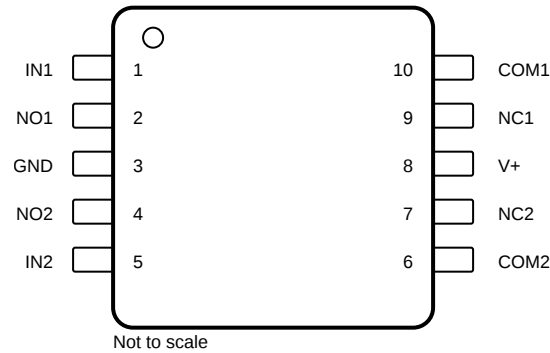
6 Specifications

6.1 Absolute Maximum Ratings

over operating free-air temperature range (unless otherwise noted)

		MIN	MAX	UNIT
V_+	Supply voltage range ⁽¹⁾	- 0.5	6.5	V
V_{NC} V_{NO} V_{COM}	Analog voltage range ^{(1) (2) (3)}	- 0.5	$V_+ + 0.5$	V
$I_{I/OK}$	Analog port diode current	$V_{NC}, V_{NO}, V_{COM} < 0$ or $V_{NC}, V_{NO}, V_{COM} > V_+$		± 50 mA
I_{NC} I_{NO} I_{COM}	On-state switch current	$V_{NC}, V_{NO}, V_{COM} = 0$ to V_+		± 50 mA
V_{IN}	Digital input voltage range ^{(1) (2)}	- 0.5	6.5	V
I_{IK}	Digital input clamp current	$V_{IN} < 0$		- 50 mA
	Continuous current through V_+ or GND			± 100 mA
θ_{JA}	Package thermal impedance ⁽⁴⁾			165.36 °C/W
T_{stg}	Storage temperature range	- 65	150	°C
ESD	Electrostatic discharge rating	Human-body model H2		2 kV
		Charged-device model C4B		750 V

- (1) All voltages are with respect to ground, unless otherwise specified.
(2) The input and output voltage ratings may be exceeded if the input and output clamp-current ratings are observed.
(3) This value is limited to 5.5 V maximum.
(4) The package thermal impedance is calculated in accordance with JESD 51-7.

6.2 Electrical Characteristics for 5-V Supply

$V_+ = 4.5 \text{ V to } 5.5 \text{ V}$, $T_A = -40^\circ\text{C to } 125^\circ\text{C}$ (unless otherwise noted)

PARAMETER	SYMBOL	TEST CONDITIONS	T_A	V_+	MIN	TYP ⁽¹⁾	MAX	UNIT
Analog Switch								
Analog signal range	V_{COM}, V_{NO}, V_{NC}				0		V_+	V
ON-state resistance	r_{on}	$0 \leq V_{NO} \text{ or } V_{NC} \leq V_+$, $I_{COM} = -30 \text{ mA}$, Switch ON, See Fig 8-1	Full	4.5 V			15	Ω
ON-state resistance match between channels	Δr_{on}	$V_{NO} \text{ or } V_{NC} = 3.15 \text{ V}$, $I_{COM} = -30 \text{ mA}$, Switch ON, See Fig 8-1	25°C	4.5 V		0.15		Ω
ON-state resistance flatness	$r_{on(Flat)}$	$0 \leq V_{NO} \text{ or } V_{NC} \leq V_+$, $I_{COM} = -30 \text{ mA}$, Switch ON, See Fig 8-1	25°C	4.5 V		4		Ω
NC, NO OFF leakage current	$I_{NC(OFF)}, I_{NO(OFF)}$	$V_{NC} \text{ or } V_{NO} = 0 \text{ to } V_+$, $V_{COM} = 0 \text{ to } V_+$, Switch OFF, See Fig 8-2	25°C	5.5 V	-1	0.05	1	μA
			Full		-1		1	
NC, NO ON leakage current	$I_{NC(ON)}, I_{NO(ON)}$	$V_{NC} \text{ or } V_{NO} = 0 \text{ to } V_+$, $V_{COM} = \text{Open}$, Switch ON, See Fig 8-2	25°C	5.5 V	-0.1		0.1	μA
			Full		-1		1	
COM ON leakage current	$I_{COM(ON)}$	$V_{NC} \text{ or } V_{NO} = \text{Open}$, $V_{COM} = 0 \text{ to } V_+$, Switch ON, See Fig 8-2	25°C	5.5 V	-0.1		0.1	μA
			Full		-1		1	
Digital Inputs (IN1, IN2)⁽²⁾								
Input logic high	V_{IH}		Full		$V_+ \times 0.7$			V
Input logic low	V_{IL}		Full		$V_+ \times 0.3$			V
Input leakage current	I_{IH}, I_{IL}	$V_{IN} = 5.5 \text{ V or } 0$	25°C	5.5 V	-1	0.05	1	μA
			Full		-1		1	

6.2 Electrical Characteristics for 5-V Supply (continued)

$V_+ = 4.5\text{ V to }5.5\text{ V}$, $T_A = -40^\circ\text{C to }125^\circ\text{C}$ (unless otherwise noted)

PARAMETER	SYMBOL	TEST CONDITIONS	T_A	V_+	MIN	TYP ⁽¹⁾	MAX	UNIT
Dynamic								
Turnon time	t_{ON}	$V_{NC} = \text{GND}$ and $V_{NO} = V_+$, or $V_{NC} = V_+$ and $V_{NO} = \text{GND}$,						
		$R_L = 500\ \Omega$, $C_L = 50\ \text{pF}$, See Fig 8-4	Full	4.5 V to 5.5 V	1.2		8.7	ns
Turnoff time	t_{OFF}	$V_{NC} = \text{GND}$ and $V_{NO} = V_+$, or $V_{NC} = V_+$ and $V_{NO} = \text{GND}$,						
		$R_L = 500\ \Omega$, $C_L = 50\ \text{pF}$, See Fig 8-4	Full	4.5 V to 5.5 V	0.5		6.8	ns
Break-before-make time	t_{BBM}	$V_{NC} = V_{NO} = V_+/2$, $R_L = 50\ \Omega$,						
		$C_L = 35\ \text{pF}$, See Fig 8-5	25°C	4.5 V to 5.5 V	0.5			ns
Charge injection	Q_C	$V_{NC} = V_{NO} = V_+/2$, $R_L = 50\ \Omega$,						
		See Fig 8-9	25°C	5 V		7		pC
NC, NO OFF capacitance	$C_{NC(OFF)}$, $C_{NO(OFF)}$	V_{NC} or $V_{NO} = V_+$ or GND,						
		Switch OFF, See Fig 8-3	25°C	5 V		5.5		pF
NC, NO ON capacitance	$C_{NC(ON)}$, $C_{NO(ON)}$	V_{NC} or $V_{NO} = V_+$ or GND,						
		Switch ON, See Fig 8-3	25°C	5 V		17.5		pF
COM ON capacitance	$C_{COM(ON)}$	$V_{COM} = V_+$ or GND,						
		Switch ON, See Fig 8-3	25°C	5 V		17.5		pF
Digital input capacitance	C_{IN}	$V_{IN} = V_+$ or GND,						
		See Fig 8-3	25°C	5 V		2.8		pF
Bandwidth	BW	$R_L = 50\ \Omega$,						
		Switch ON, See Fig 8-6	25°C	4.5 V		220		MHz
OFF isolation	O_{ISO}	$R_L = 50\ \Omega$, $f = 10\ \text{MHz}$,						
		Switch OFF, See Fig 8-7	25°C	4.5 V		-65		dB
Crosstalk	X_{TALK}	$R_L = 50\ \Omega$, $f = 10\ \text{MHz}$,						
		Switch ON, See Fig 8-8	25°C	4.5 V		-66		dB
Total harmonic distortion	THD	$R_L = 600\ \Omega$, $C_L = 50\ \text{pF}$,						
		$f = 600\ \text{Hz to }20\ \text{kHz}$, See Fig 8-10	25°C	4.5 V		0.01		%
Supply								
Positive supply current	I_+	$V_{IN} = V_+$ or GND,	Switch ON or OFF	25°C	5.5 V			1
				Full				10
Change in supply current	ΔI_+	$V_{IN} = V_+ - 0.6\ \text{V}$		Full	5.5 V			500
								μA

(1) $T_A = 25^\circ\text{C}$

(2) Hold all unused digital inputs of the device at V_+ or GND to ensure proper device operation. See the TI application report, *Implications of Slow or Floating CMOS Inputs*, literature number [SCBA004](#).

6.3 Electrical Characteristics for 3.3-V Supply

$V_+ = 3\text{ V to }3.6\text{ V}$, $T_A = -40^\circ\text{C to }125^\circ\text{C}$ (unless otherwise noted)

PARAMETER	SYMBOL	TEST CONDITIONS	T_A	V_+	MIN	TYP ⁽¹⁾	MAX	UNIT
Analog Switch								
Analog signal range	V_{COM}, V_{NO}, V_{NC}				0		V_+	V
ON-state resistance	r_{on}	$0 \leq V_{NO} \text{ or } V_{NC} \leq V_+$, $I_{COM} = -24\text{ mA}$, Switch ON, See Fig 8-1	Full	3 V			23	Ω
ON-state resistance match between channels	Δr_{on}	$V_{NO} \text{ or } V_{NC} = 2.1\text{ V}$, $I_{COM} = -24\text{ mA}$, Switch ON, See Fig 8-1	25°C	3 V		0.2		Ω
ON-state resistance flatness	$r_{on(flat)}$	$0 \leq V_{NO} \text{ or } V_{NC} \leq V_+$, $I_{COM} = -24\text{ mA}$, Switch ON, See Fig 8-1	25°C	3 V		9		Ω
NC, NO OFF leakage current	$I_{NC(OFF)}, I_{NO(OFF)}$	$V_{NC} \text{ or } V_{NO} = 0 \text{ to } V_+$, $V_{COM} = 0 \text{ to } V_+$, Switch OFF, See Fig 8-2	25°C	3.6 V	-1	0.05	1	μA
			Full		-1		1	
NC, NO ON leakage current	$I_{NC(ON)}, I_{NO(ON)}$	$V_{NC} \text{ or } V_{NO} = 0 \text{ to } V_+$, $V_{COM} = \text{Open}$, Switch ON, See Fig 8-2	25°C	3.6 V	-0.1		0.1	μA
			Full		-1		1	
COM ON leakage current	$I_{COM(ON)}$	$V_{NC} \text{ or } V_{NO} = \text{Open}$, $V_{COM} = 0 \text{ to } V_+$, Switch ON, See Fig 8-2	25°C	3.6 V	-0.1		0.1	μA
			Full		-1		1	
Digital Inputs (IN1, IN2)⁽²⁾								
Input logic high	V_{IH}		Full		$V_+ \times 0.7$			V
Input logic low	V_{IL}		Full		$V_+ \times 0.3$			V
Input leakage current	I_{IH}, I_{IL}	$V_{IN} = 5.5\text{ V or }0$	25°C	3.6 V	-1	0.05	1	μA
			Full		-1		1	
Dynamic								
Turnon time	t_{ON}	$V_{NC} = \text{GND and } V_{NO} = V_+$, or $V_{NC} = V_+ \text{ and } V_{NO} = \text{GND}$, $R_L = 500\ \Omega$, $C_L = 50\text{ pF}$, See Fig 8-4	Full	3 V to 3.6 V	2.0		10.6	ns
Turnoff time	t_{OFF}	$V_{NC} = \text{GND and } V_{NO} = V_+$, or $V_{NC} = V_+ \text{ and } V_{NO} = \text{GND}$, $R_L = 500\ \Omega$, $C_L = 50\text{ pF}$, See Fig 8-4	Full	3 V to 3.6 V	1.0		8.3	ns
Break-before-make time	t_{BBM}	$V_{NC} = V_{NO} = V_+/2$, $R_L = 50\ \Omega$, See Fig 8-5	25°C	3 V to 3.6 V	0.5			ns
Charge injection	Q_C	$R_L = 50\ \Omega$, $C_L = 0.1\text{ nF}$, See Fig 8-9	25°C	3.3 V		3		pC
Bandwidth	BW	$R_L = 50\ \Omega$, Switch ON, See Fig 8-6	25°C	3 V		220		MHz
OFF isolation	O_{ISO}	$R_L = 50\ \Omega$, $f = 10\text{ MHz}$, Switch OFF, See Fig 8-7	25°C	3 V		-65		dB
Crosstalk	X_{TALK}	$R_L = 50\ \Omega$, $f = 10\text{ MHz}$, Switch ON, See Fig 8-8	25°C	3 V		-66		dB
Total harmonic distortion	THD	$R_L = 600\ \Omega$, $C_L = 50\text{ pF}$, $f = 600\text{ Hz to }20\text{ kHz}$, See Fig 8-10	25°C	3 V		0.015		%
Supply								
Positive supply current	I_+	$V_{IN} = V_+ \text{ or } \text{GND}$, Switch ON or OFF	25°C	3.6 V			1	μA
			Full				10	
Change in supply current	ΔI_+	$V_{IN} = V_+ - 0.6\text{ V}$	Full	3.6 V			500	μA

(1) $T_A = 25^\circ\text{C}$

- (2) Hold all unused digital inputs of the device at V+ or GND to ensure proper device operation. See the TI application report, *Implications of Slow or Floating CMOS Inputs*, literature number [SCBA004](#).

6.4 Electrical Characteristics for 2.5-V Supply

$V_+ = 2.3 \text{ V to } 2.7 \text{ V}$, $T_A = -40^\circ\text{C to } 125^\circ\text{C}$ (unless otherwise noted)

PARAMETER	SYMBOL	TEST CONDITIONS	T_A	V_+	MIN	TYP ⁽¹⁾	MAX	UNIT
Analog Switch								
Analog signal range	V_{COM}, V_{NO}, V_{NC}				0		V_+	V
ON-state resistance	r_{on}	$0 \leq V_{NO} \text{ or } V_{NC} \leq V_+$, $I_{COM} = -8 \text{ mA}$, Switch ON, See Fig 8-1	Full	2.3 V			50	Ω
ON-state resistance match between channels	Δr_{on}	$V_{NO} \text{ or } V_{NC} = 1.6 \text{ V}$, $I_{COM} = -8 \text{ mA}$, Switch ON, See Fig 8-1	25°C	2.3 V		0.5		Ω
ON-state resistance flatness	$r_{on(flat)}$	$0 \leq V_{NO} \text{ or } V_{NC} \leq V_+$, $I_{COM} = -8 \text{ mA}$, Switch ON, See Fig 8-1	25°C	2.3 V		27		Ω
NC, NO OFF leakage current	$I_{NC(OFF)}, I_{NO(OFF)}$	$V_{NC} \text{ or } V_{NO} = 0 \text{ to } V_+$, $V_{COM} = 0 \text{ to } V_+$, Switch OFF, See Fig 8-2	25°C	2.7 V	-1	0.05	1	μA
			Full		-1		1	
NC, NO ON leakage current	$I_{NC(ON)}, I_{NO(ON)}$	$V_{NC} \text{ or } V_{NO} = 0 \text{ to } V_+$, $V_{COM} = \text{Open}$, Switch ON, See Fig 8-2	25°C	2.7 V	-0.1		0.1	μA
			Full		-1		1	
COM ON leakage current	$I_{COM(ON)}$	$V_{NC} \text{ or } V_{NO} = \text{Open}$, $V_{COM} = 0 \text{ to } V_+$, Switch ON, See Fig 8-2	25°C	2.7 V	-0.1		0.1	μA
			Full		-1		1	
Digital Inputs (IN1, IN2)⁽²⁾								
Input logic high	V_{IH}		Full		$V_+ \times 0.7$			V
Input logic low	V_{IL}		Full		$V_+ \times 0.3$			V
Input leakage current	I_{IH}, I_{IL}	$V_{IN} = 5.5 \text{ V or } 0$	25°C	2.7 V	-1	0.05	1	μA
			Full		-1		1	
Dynamic								
Turnon time	t_{ON}	$V_{NC} = \text{GND and } V_{NO} = V_+$, or $V_{NC} = V_+ \text{ and } V_{NO} = \text{GND}$, $R_L = 500 \Omega$, $C_L = 50 \text{ pF}$, See Fig 8-4	Full	2.3 V to 2.7 V	2.5		17	ns
Turnoff time	t_{OFF}	$V_{NC} = \text{GND and } V_{NO} = V_+$, or $V_{NC} = V_+ \text{ and } V_{NO} = \text{GND}$, $R_L = 500 \Omega$, $C_L = 50 \text{ pF}$, See Fig 8-4	Full	2.3 V to 2.7 V	1.5		10.5	ns
Break-before-make time	t_{BBM}	$V_{NC} = V_{NO} = V_+/2$, $R_L = 50 \Omega$, $C_L = 35 \text{ pF}$, See Fig 8-5	25°C	2.3 V to 2.7 V	0.5			ns
Bandwidth	BW	$R_L = 50 \Omega$, Switch ON, See Fig 8-6	25°C	2.3 V		220		MHz
OFF isolation	O_{ISO}	$R_L = 50 \Omega$, $f = 10 \text{ MHz}$, Switch OFF, See Fig 8-7	25°C	2.3 V		-65		dB
Crosstalk	X_{TALK}	$R_L = 50 \Omega$, $f = 10 \text{ MHz}$, Switch ON, See Fig 8-8	25°C	2.3 V		-66		dB
Total harmonic distortion	THD	$R_L = 600 \Omega$, $C_L = 50 \text{ pF}$, $f = 600 \text{ Hz to } 20 \text{ kHz}$, See Fig 8-10	25°C	2.3 V		0.025		%
Supply								
Positive supply current	I_+	$V_{IN} = V_+ \text{ or } \text{GND}$, Switch ON or OFF	25°C	2.7 V			1	μA
			Full				10	
Change in supply current	ΔI_+	$V_{IN} = V_+ - 0.6 \text{ V}$	Full	2.7 V			500	μA

(1) $T_A = 25^\circ\text{C}$

(2) Hold all unused digital inputs of the device at V_+ or GND to ensure proper device operation. See the TI application report, *Implications of Slow or Floating CMOS Inputs*, literature number [SCBA004](#).

6.5 Electrical Characteristics for 1.8-V Supply

 $V_+ = 1.65\text{ V to }1.95\text{ V}$, $T_A = -40^\circ\text{C to }125^\circ\text{C}$ (unless otherwise noted)

PARAMETER	SYMBOL	TEST CONDITIONS	T_A	V_+	MIN	TYP ⁽¹⁾	MAX	UNIT
Analog Switch								
Analog signal range	V_{COM}, V_{NO}, V_{NC}				0		V_+	V
ON-state resistance	r_{on}	$0 \leq V_{NO} \text{ or } V_{NC} \leq V_+$, $I_{COM} = -4\text{ mA}$, Switch ON, See Fig 8-1	Full	1.65 V			180	Ω
ON-state resistance match between channels	Δr_{on}	$V_{NO} \text{ or } V_{NC} = 1.15\text{ V}$, $I_{COM} = -4\text{ mA}$, Switch ON, See Fig 8-1	25°C	1.65 V		1		Ω
ON-state resistance flatness	$r_{on(Flat)}$	$0 \leq V_{NO} \text{ or } V_{NC} \leq V_+$, $I_{COM} = -4\text{ mA}$, Switch ON, See Fig 8-1	25°C	1.65 V		110		Ω
NC, NO OFF leakage current	$I_{NC(OFF)}, I_{NO(OFF)}$	$V_{NC} \text{ or } V_{NO} = 0 \text{ to } V_+$, $V_{COM} = 0 \text{ to } V_+$, Switch OFF, See Fig 8-2	25°C	1.95 V	-1	0.05	1	μA
			Full		-1		1	
NC, NO ON leakage current	$I_{NC(ON)}, I_{NO(ON)}$	$V_{NC} \text{ or } V_{NO} = 0 \text{ to } V_+$, $V_{COM} = \text{Open}$, Switch ON, See Fig 8-2	25°C	1.95 V	-0.1		0.1	μA
			Full		-1		1	
COM ON leakage current	$I_{COM(ON)}$	$V_{NC} \text{ or } V_{NO} = \text{Open}$, $V_{COM} = 0 \text{ to } V_+$, Switch ON, See Fig 8-2	25°C	1.95 V	-0.1		0.1	μA
			Full		-1		1	
Digital Inputs (IN1, IN2)⁽²⁾								
Input logic high	V_{IH}		Full		$V_+ \times 0.75$			V
Input logic low	V_{IL}		Full		$V_+ \times 0.25$			V
Input leakage current	I_{IH}, I_{IL}	$V_{IN} = 5.5\text{ V or }0$	25°C	1.95 V	-1	0.05	1	μA
			Full		-1		1	
Dynamic								
Turnon time	t_{ON}	$V_{NC} = \text{GND and } V_{NO} = V_+$, or $V_{NC} = V_+ \text{ and } V_{NO} = \text{GND}$, $R_L = 500\ \Omega$, $C_L = 50\text{ pF}$, See Fig 8-4	Full	1.65 V to 1.95 V	5.5		27	ns
Turnoff time	t_{OFF}	$V_{NC} = \text{GND and } V_{NO} = V_+$, or $V_{NC} = V_+ \text{ and } V_{NO} = \text{GND}$, $R_L = 500\ \Omega$, $C_L = 50\text{ pF}$, See Fig 8-4	Full	1.65 V to 1.95 V	2		16	ns
Break-before-make time	t_{BBM}	$V_{NC} = V_{NO} = V_+/2$, $R_L = 50\ \Omega$, $C_L = 35\text{ pF}$, See Fig 8-5	25°C	1.65 V to 1.95 V	0.5			ns
Bandwidth	BW	$R_L = 50\ \Omega$, Switch ON, See Fig 8-6	25°C	1.8 V		220		MHz
OFF isolation	O_{ISO}	$R_L = 50\ \Omega$, $f = 10\text{ MHz}$, Switch OFF, See Fig 8-7	25°C	1.8 V		-60		dB
Crosstalk	X_{TALK}	$R_L = 50\ \Omega$, $f = 10\text{ MHz}$, Switch ON, See Fig 8-8	25°C	1.8 V		-66		dB
Total harmonic distortion	THD	$R_L = 600\ \Omega$, $C_L = 50\text{ pF}$, $f = 600\text{ Hz to }20\text{ kHz}$, See Fig 8-10	25°C	1.8 V		0.015		%
Supply								
Positive supply current	I_+	$V_{IN} = V_+ \text{ or } \text{GND}$, Switch ON or OFF	25°C	1.95 V			1	μA
			Full				10	
Change in supply current	ΔI_+	$V_{IN} = V_+ - 0.6\text{ V}$	Full	1.95 V			500	μA

 (1) $T_A = 25^\circ\text{C}$

 (2) Hold all unused digital inputs of the device at V_+ or GND to ensure proper device operation. See the TI application report, *Implications of Slow or Floating CMOS Inputs*, literature number [SCBA004](#).

6.6 Typical Characteristics



图 6-1. r_{ON} versus V_{COM}



图 6-2. t_{ON} and t_{OFF} versus V_+

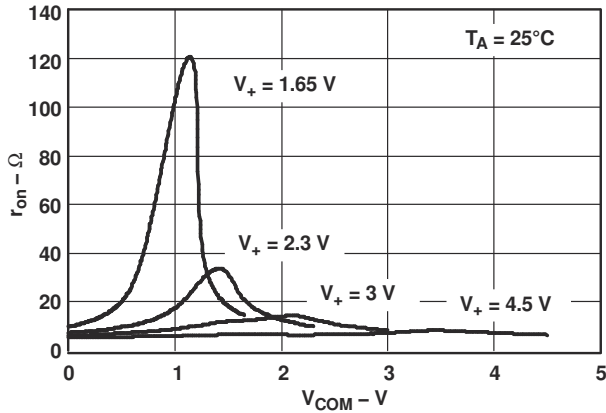

图 6-3. t_{ON} and t_{OFF} versus Temperature ($V_+ = 5V$)

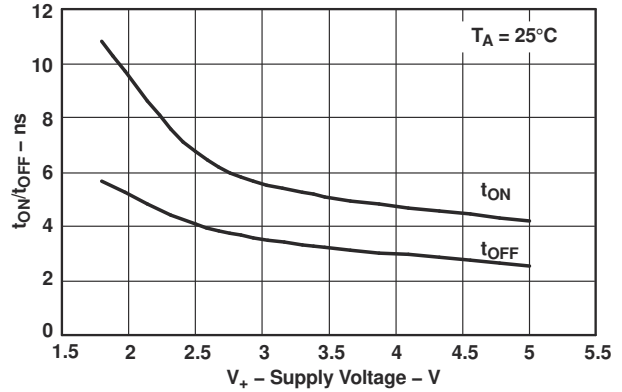

图 6-4. Frequency Response ($V_+ = 3V$)

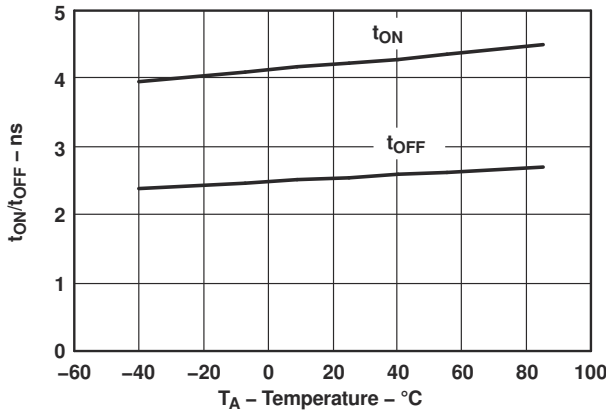

图 6-5. Total Harmonic Distortion (THD) versus Frequency ($V_+ = 3V$)

7 Parameter Description

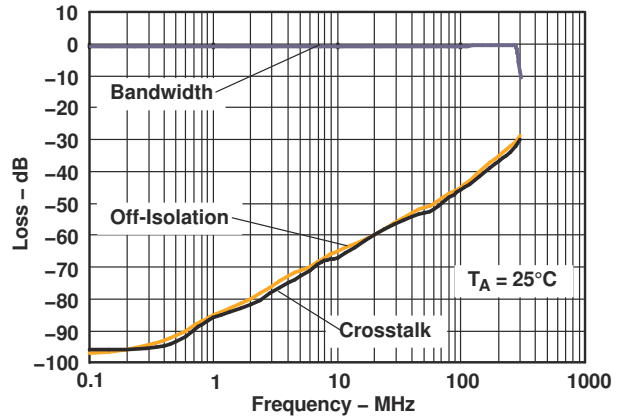
SYMBOL	DESCRIPTION
V_{COM}	Voltage at COM
V_{NC}	Voltage at NC
V_{NO}	Voltage at NO
r_{on}	Resistance between COM and NC or COM and NO ports when the channel is ON
Δr_{on}	Difference of r_{on} between channels
$r_{on(Flat)}$	Difference between the maximum and minimum value of r_{on} in a channel over the specified range of conditions
$I_{NC(OFF)}$	Leakage current measured at the NC port, with the corresponding channel (NC to COM) in the OFF state under worst-case input and output conditions
$I_{NO(OFF)}$	Leakage current measured at the NO port, with the corresponding channel (NO to COM) in the OFF state under worst-case input and output conditions
$I_{NC(ON)}$	Leakage current measured at the NC port, with the corresponding channel (NC to COM) in the ON state and the output (COM) being open
$I_{NO(ON)}$	Leakage current measured at the NO port, with the corresponding channel (NO to COM) in the ON state and the output (COM) being open
$I_{COM(ON)}$	Leakage current measured at the COM port, with the corresponding channel (NO to COM or NC to COM) in the ON state and the output (NC or NO) being open
V_{IH}	Minimum input voltage for logic high for the control input (IN)
V_{IL}	Minimum input voltage for logic low for the control input (IN)
V_{IN}	Voltage at IN
I_{IH}, I_{IL}	Leakage current measured at IN
t_{ON}	Turnon time for the switch. Measure this parameter under the specified range of conditions and by the propagation delay between the digital control (IN) signal and analog output (COM/NC/NO) signal when the switch is turning ON.
t_{OFF}	Turnoff time for the switch. Measure this parameter under the specified range of conditions and by the propagation delay between the digital control (IN) signal and analog output (COM/NC/NO) signal when the switch is turning OFF.
t_{BBM}	Break-before-make time. Measure this parameter under the specified range of conditions and by the propagation delay between the output of two adjacent analog channels (NC and NO) when the control signal changes state.
Q_C	Charge injection is a measurement of unwanted signal coupling from the control (IN) input to the analog (NC, NO, or COM) output. This measure is in coulombs (C) and is the total charge induced due to switching of the control input. Charge injection, $Q_C = C_L \times \Delta V_O$, C_L is the load capacitance and ΔV_O is the change in analog output voltage.
$C_{NC(OFF)}$	Capacitance at the NC port when the corresponding channel (NC to COM) is OFF
$C_{NO(OFF)}$	Capacitance at the NO port when the corresponding channel (NC to COM) is OFF
$C_{NC(ON)}$	Capacitance at the NC port when the corresponding channel (NC to COM) is ON
$C_{NO(ON)}$	Capacitance at the NO port when the corresponding channel (NC to COM) is ON
$C_{COM(ON)}$	Capacitance at the COM port when the corresponding channel (COM to NC or COM to NO) is ON
C_{IN}	Capacitance of IN
O_{ISO}	OFF isolation of the switch is a measurement of OFF-state switch impedance. This measure is in dB at a specific frequency, with the corresponding channel (NC to COM or NO to COM) in the OFF state. OFF isolation, $O_{ISO} = 20 \text{ LOG}(V_{NC}/V_{COM})$ dB, V_{COM} is the input and V_{NC} is the output.
X_{TALK}	Crosstalk is a measurement of unwanted signal coupling from an ON channel to an OFF channel (NC to NO or NO to NC). This measure is at a specific frequency and in dB. Crosstalk, $X_{TALK} = 20 \text{ log}(V_{NC1}/V_{NO1})$, V_{NO1} is the input and V_{NC1} is the output.
BW	Bandwidth of the switch. This is the frequency where the gain of an ON channel is - 3 dB below the dc gain. Gain is measured from the equation, $20 \text{ log}(V_{NC}/V_{COM})$ dB, where V_{NC} is the output and V_{COM} is the input.
I_+	Static power-supply current with the control (IN) pin at V_+ or GND
ΔI_+	This is the increase in I_+ for each control (IN) input that is at the specified voltage, rather than at V_+ or GND.

8 Parameter Measurement Information

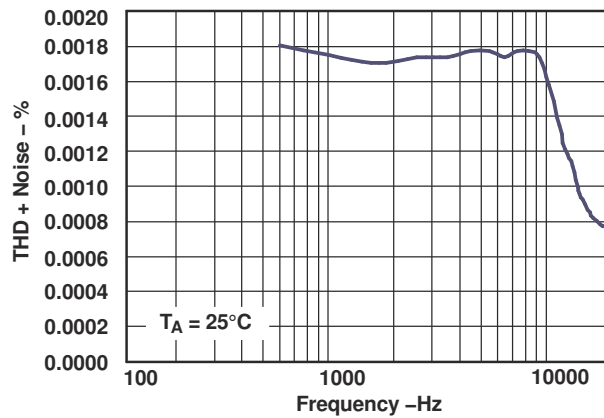

图 8-1. ON-State Resistance (R_{on})



图 8-2. ON- and OFF-State Leakage Current ($I_{COM(ON)}$, $I_{NC(OFF)}$, $I_{NO(OFF)}$, $I_{NC(ON)}$, $I_{NO(ON)}$)

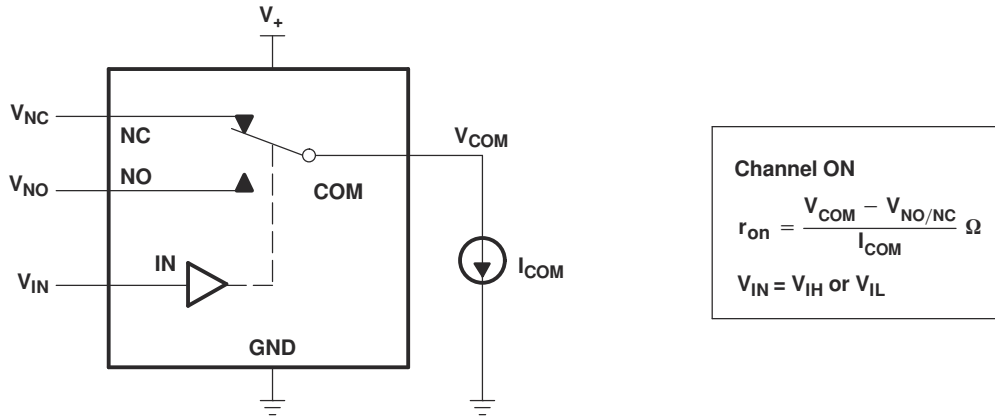

图 8-3. Capacitance (C_{IN} , $C_{COM(ON)}$, $C_{NC(OFF)}$, $C_{NO(OFF)}$, $C_{NC(ON)}$, $C_{NO(ON)}$)

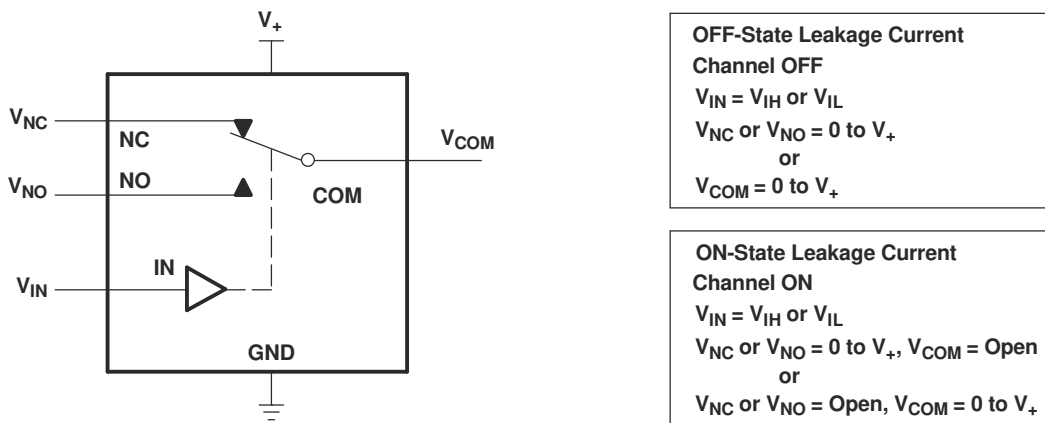

图 8-4. Turn-On Time (t_{ON}) and Turn-Off Time (t_{OFF})

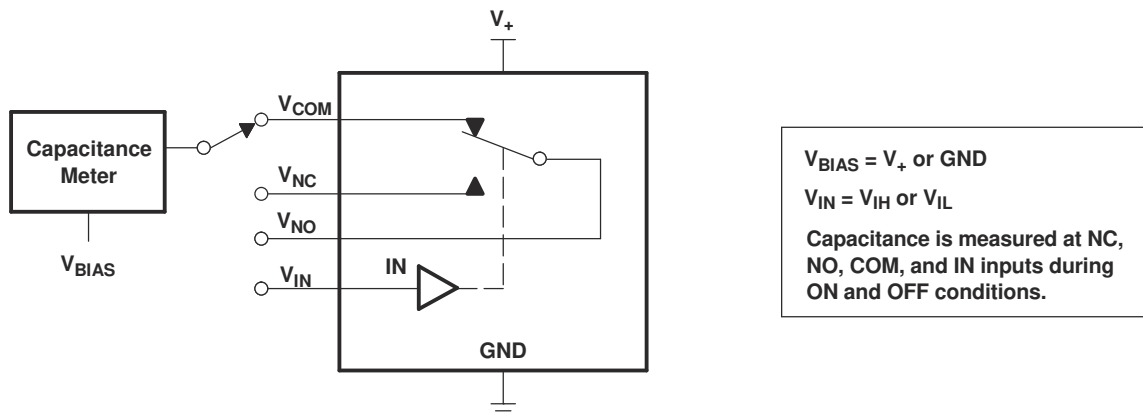

图 8-5. Break-Before-Make Time (t_{BBM})

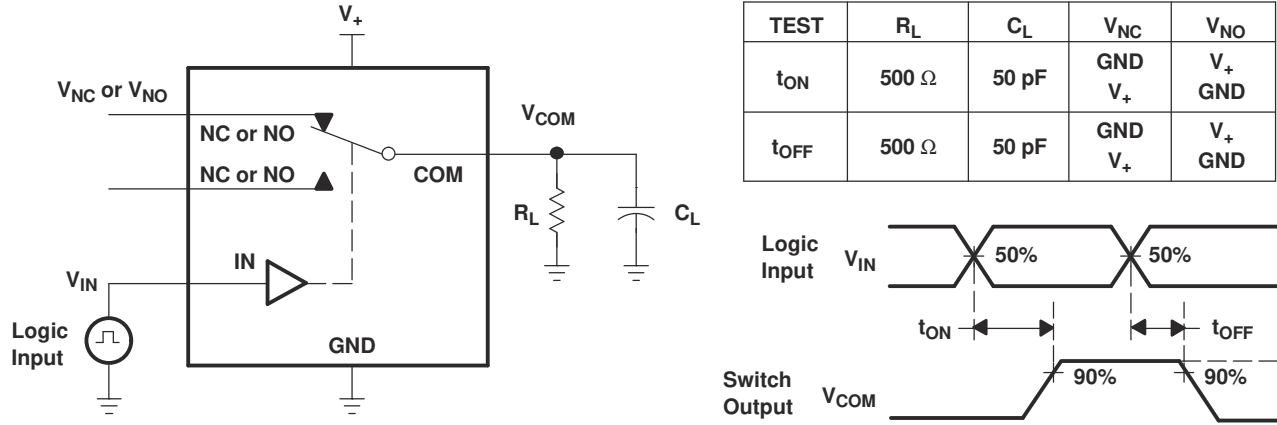

图 8-6. Frequency Response (BW)

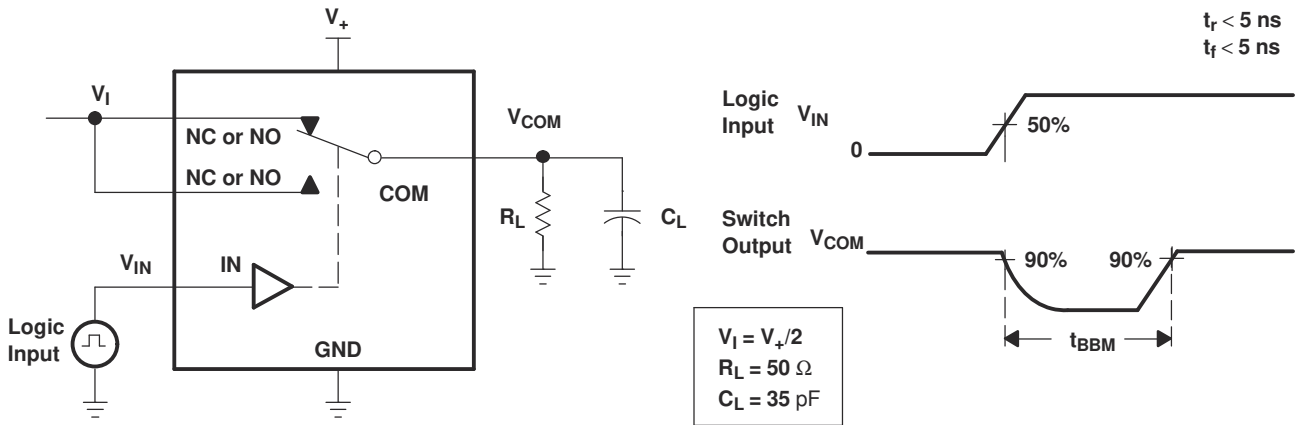

Channel OFF: NC to COM
OFF Isolation = $20 \log \frac{V_{COM}}{V_{NC}}$ dB

Network Analyzer Setup
Source Power = 0 dBm
DC Bias = 350 mV

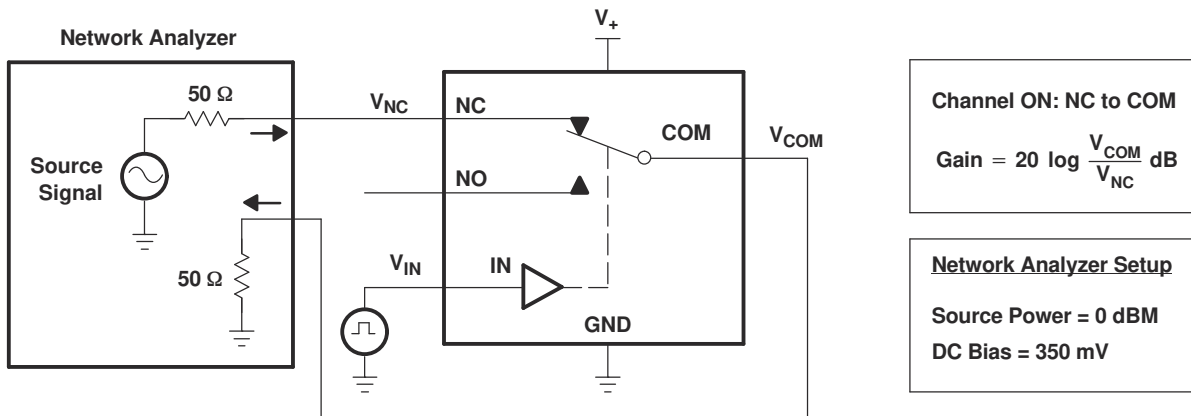
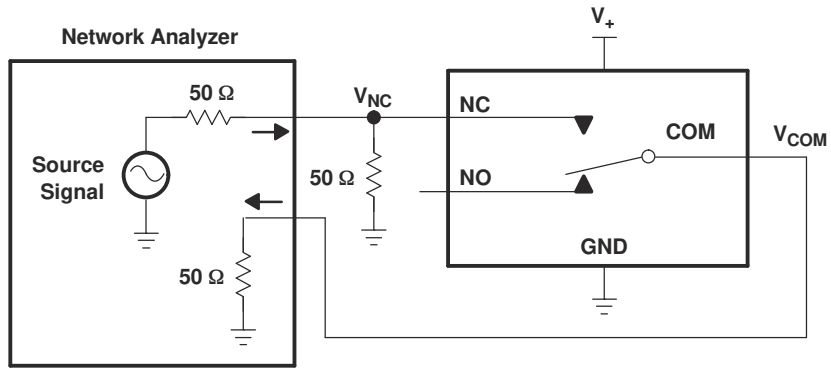
图 8-7. OFF Isolation (O_{ISO})

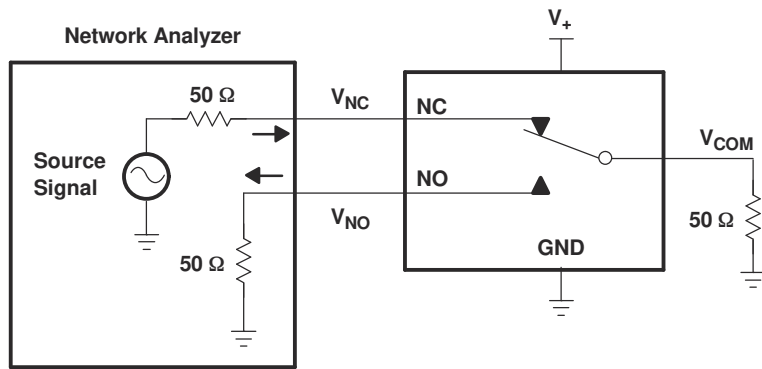

Channel ON: NC to COM
Channel OFF: NO to COM
Crosstalk = $20 \log \frac{V_{NO}}{V_{NC}}$ dB

Network Analyzer Setup
Source Power = 0 dBm
DC Bias = 350 mV

图 8-8. Crosstalk (X_{TALK})

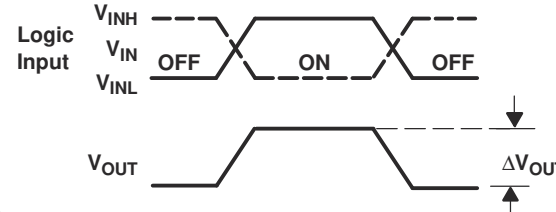
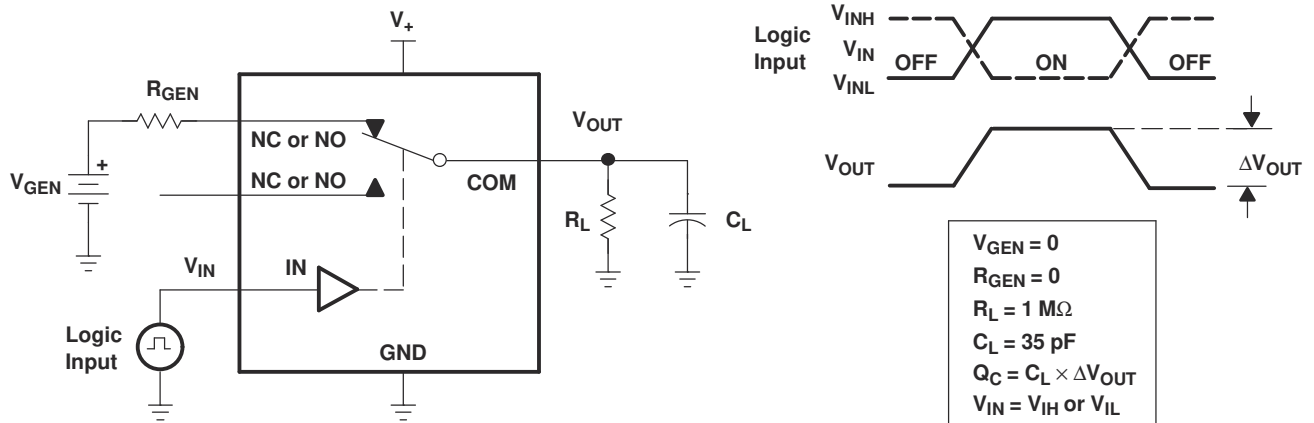

$V_{GEN} = 0$
 $R_{GEN} = 0$
 $R_L = 1 \text{ M}\Omega$
 $C_L = 35 \text{ pF}$
 $Q_C = C_L \times \Delta V_{OUT}$
 $V_{IN} = V_{IH} \text{ or } V_{IL}$

图 8-9. Charge Injection (Q_C)



图 8-10. Total Harmonic Distortion (THD)

9 Function and Summary of Characteristics

Input In	NC to COM COM to NC	NO to COM COM to NO
L	ON	OFF
H	OFF	ON

表 9-1. Summary of Characteristics

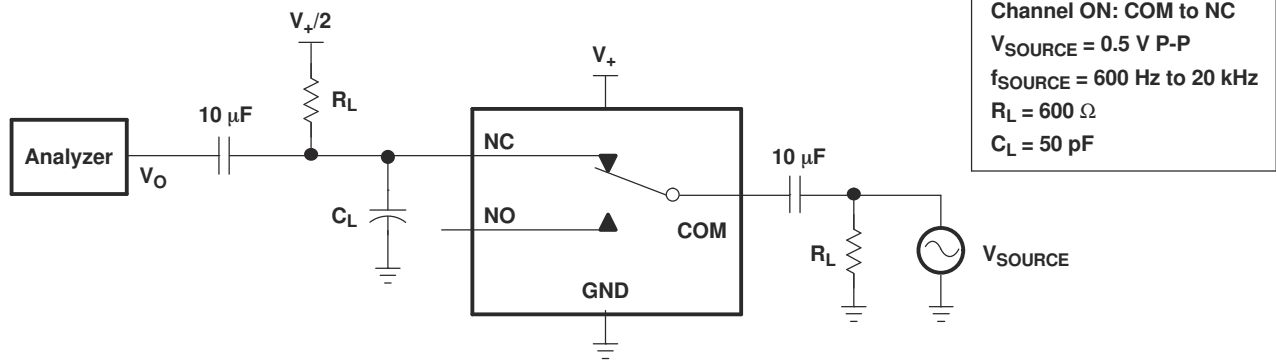
Configuration	2:1 Multiplexer and Demultiplexer (2 × SPDT)
Number of channels	2
r_{on}	15 Ω
Δr_{on}	0.15 Ω
$r_{on(flat)}$	4 Ω
t_{ON}	8.7 ns
t_{OFF}	6.8 ns
t_{BBM}	0.5 ns
Charge injection	7 pC
Bandwidth	220 MHz
OFF isolation	- 65 dB at 10 MHz
Crosstalk	- 66 dB at 10 MHz
Total harmonic distortion	0.01%
$I_{COM(off)}/I_{NC(OFF)}$	$\pm 1 \mu A$
Package option	10-pin DGS

10 Detailed Description

10.1 Overview

The TS5A23157-Q1 is a 2 channel 2:1 switch (SPDT). It has a wide operating supply of 1.8 V to 5.5 V that allows for use in a wide array of applications from sample and hold circuits to communication protocol switching such as I2C or UART. The device supports bidirectional analog and digital signals on the source (NCx and NOx) and drain (COMx) pins.

10.2 Functional Block Diagram



图 10-1. TS5A23157-Q1 Functional Block Diagram

10.3 Feature Description

Bidirectional Operation

The TS5A23157-Q1 conducts equally well from source (NCx and NOx) to drain (COMx) or from drain (COMx) to source (NCx and NOx). Each channel has similar characteristics in both directions and supports both analog and digital signals.

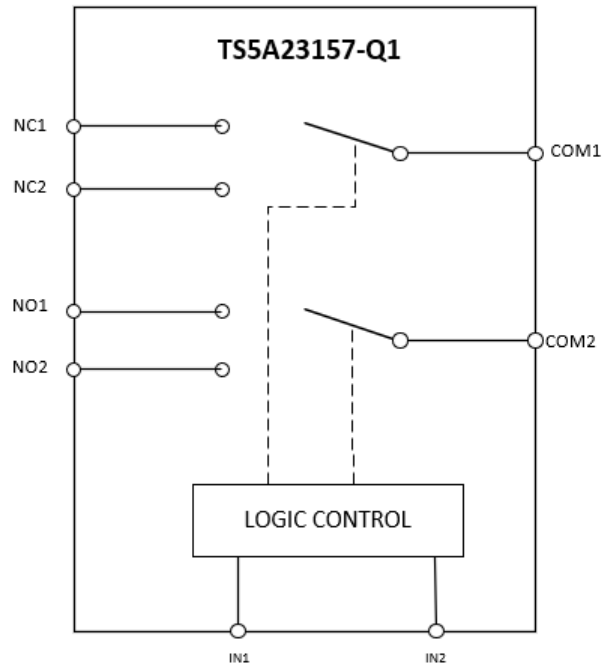
10.4 Device Functional Modes

The digital control pins (IN1 and IN2) are the logic pins that control their respective common connections (COM1 and COM2) with both the normally closed pathways (NC1 and NC2) and the normally open pathways (NO1 and NO2). When either or both digital control pins (IN1 and IN2) are pulled low their respective common (COM1 and COM2) and normally closed (NC1 and NC2) pins are connected. When either or both digital control pins (IN1 and IN2) are pulled high their respective common (COM1 and COM2) and normally open (NO1 and NO2) pins are connected.

The TS5A23157-Q1 can be operated without any external components except for the supply decoupling capacitors. Unused logic control pins (INx) should be tied to GND or VDD in order to ensure the device does not consume additional current as highlighted in Implications of Slow or Floating CMOS Inputs. Unused signal path inputs (NCx, NOx, and COMx) should be connected to GND.

11 Application and Implementation

Note

Information in the following applications sections is not part of the TI component specification, and TI does not warrant its accuracy or completeness. TI's customers are responsible for determining suitability of components for their purposes, as well as validating and testing their design implementation to confirm system functionality.

11.1 Application Information

Common applications that require the features of the TS5A23157-Q1 include multiplexing various protocols from a processor MCU such as I2C, UART, or standard GPIO signals. With the TS5A23157-Q1's wide operating supply range different variations of signal levels with GPIO, UART, and I2C can all be passed and the supply voltage can vary with the needs of the system designer. A typical UART application is shown in the Typical Application Section.

11.2 Typical Application



图 11-1. TS5A23157-Q1 Used in UART Application

11.3 Design Requirements

For the typical application shown above - please use the following parameters shown below.

表 11-1. Design Parameters

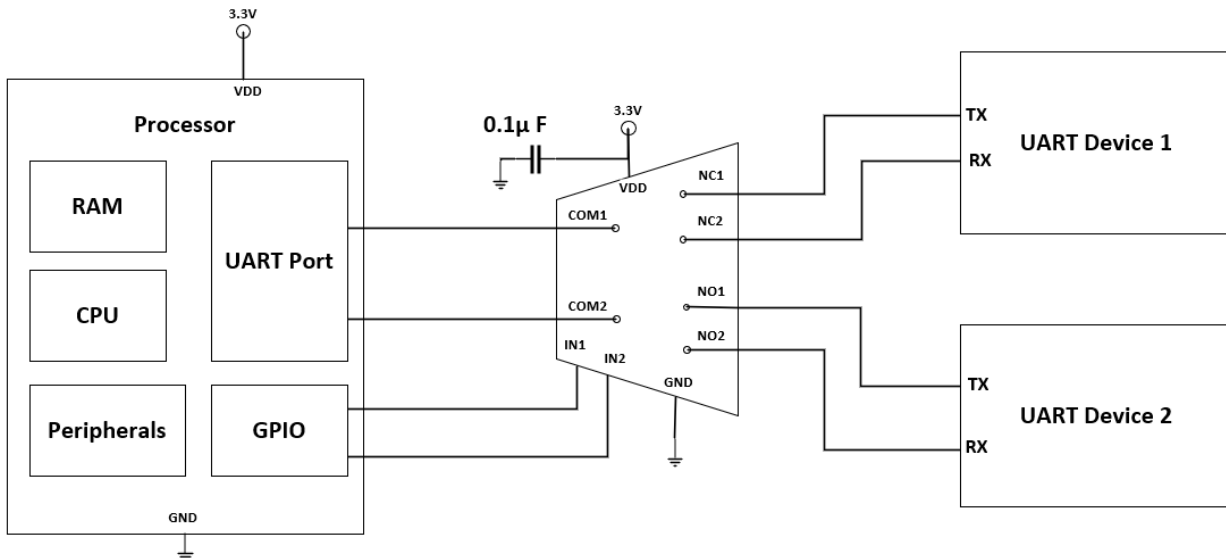
PARAMETER	VALUE
Supply Voltage	3.3 V
Input / Output Voltage	0 V - 3.3 V
Logic Input High	2.31 V - 3.3 V
Logic Input Low	0 V - 0.99 V

11.4 Detailed Design Procedure

The TS5A23157-Q1 can be operated without any external components except for the supply decoupling capacitors. To ensure known logic states at start up - use pull-down resistors, between 10 K Ω and 100 K Ω , on each control input (INx). All inputs signals passing through the switch must fall within the recommend operating conditions of the TS5A23157-Q1 including signal range and continuous current. For this design example, with a supply of 3.3 V, the signals can range from 0 V to 3.3 V when the device is powered. Due to the voltage range and bandwidth of the switch, it can support many applications such as I2C, UART, and GPIO switching.

11.5 Application Performance Plots

Three important parameters when using the TS5A23157-Q1 in any communication protocol / GPIO switching application are the bandwidth of the switch as well as off isolation and cross talk. The below figure shows the typical bandwidth, off isolation, and cross talk versus frequency. When implementing this use case of the switch it is crucial to understand the AC error that other signals may create when using this device.



图 11-2. AC Parameters for TS5A23157-Q1 (V+ = 3V)

12 Power Supply Recommendations

The TS5A23157-Q1 operates across a wide supply range of 1.8 V to 5.5 V. Do not exceed the absolute maximum ratings because stresses beyond the listed ratings can cause permanent damage to the devices. Power-supply bypassing improves noise margin and prevents switching noise propagation from the VDD supply to other components. Good power-supply decoupling is important to achieve optimum performance. For improved supply noise immunity, use a supply decoupling capacitor ranging from 0.1 μ F to 10 μ F from VDD to ground. Place the bypass capacitors as close to the power supply pins of the device as possible using low-impedance connections. TI recommends using multi-layer ceramic chip capacitors (MLCCs) that offer low equivalent series resistance (ESR) and inductance (ESL) characteristics for power-supply decoupling purposes. For very sensitive systems, or for systems in harsh noise environments, avoiding the use of vias for connecting the capacitors to the device pins may offer superior noise immunity. The use of multiple vias in parallel lowers the overall inductance and is beneficial for connections to ground planes.

13 Layout

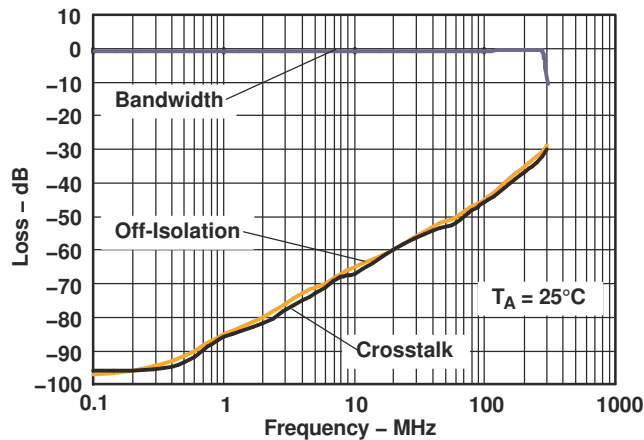
13.1 Layout Guidelines

When a PCB trace turns a corner at a 90° angle, a reflection can occur. A reflection occurs primarily because of the change of width of the trace. At the apex of the turn, the trace width increases to 1.414 times the width. This increase upsets the transmission-line characteristics, especially the distributed capacitance and self-inductance of the trace which results in the reflection. Not all PCB traces can be straight and therefore some traces must turn corners. The figure below shows progressively better techniques of rounding corners. Only the last example (BEST) maintains constant trace width and minimizes reflections.



图 13-1. Trace Guidelines for TS5A23157-Q1

Route the high-speed signals using a minimum of vias and corners which reduces signal reflections and impedance changes. When a via must be used, increase the clearance size around it to minimize its capacitance. Each via introduces discontinuities in the signal's transmission line and increases the chance of picking up interference from the other layers of the board. Be careful when designing test points, through-hole pins are not recommended at high frequencies. Do not route high speed signal traces under or near crystals, oscillators, clock signal generators, switching regulators, mounting holes, magnetic devices or ICs that use or duplicate clock signals. Avoid stubs on the high-speed signals traces because they cause signal reflections. Route all high-speed signal traces over continuous GND planes, with no interruptions. Avoid crossing over anti-etch, commonly found with plane splits. When working with high frequencies, a printed circuit board with at least four layers is recommended; two signal layers separated by a ground and power layer as shown below.

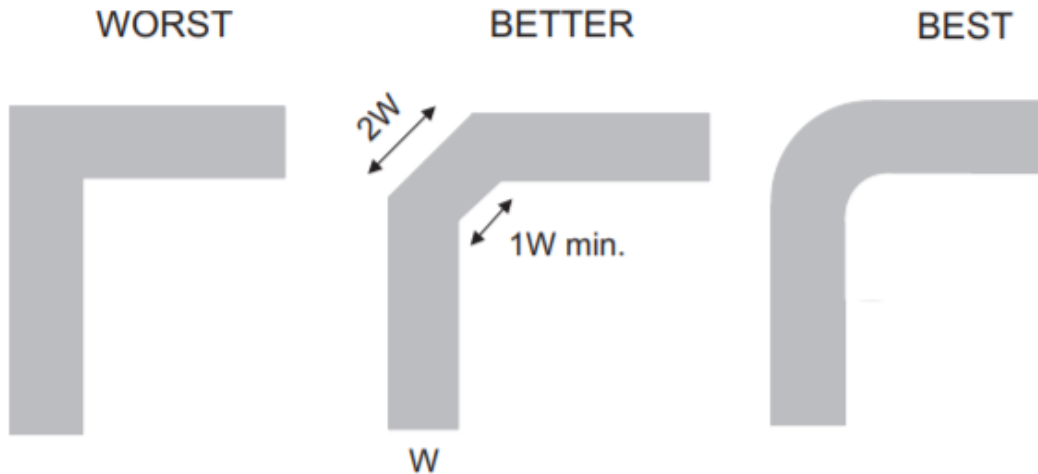

图 13-2. Layer Stack Example for TS5A23157-Q1 device.

13.2 Layout Example

- Decouple the VDD pin with a 0.1 μ F capacitor, placed as close to the pin as possible.
- Make sure that the capacitor voltage rating is sufficient for the VDD supply.
- High-speed switches require proper layout and design procedures for optimum performance.
- Keep the input lines as short as possible.
- Use a solid ground plane to help reduce electromagnetic interference (EMI) noise pickup.

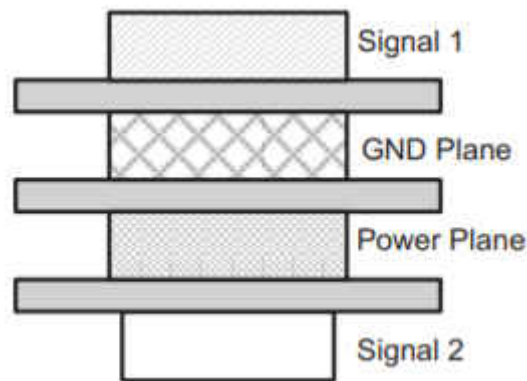

图 13-3. Layout Example of TS5A23157-Q1

14 Device and Documentation Support

14.1 接收文档更新通知

要接收文档更新通知，请导航至 ti.com 上的器件产品文件夹。点击 [订阅更新](#) 进行注册，即可每周接收产品信息更改摘要。有关更改的详细信息，请查看任何已修订文档中包含的修订历史记录。

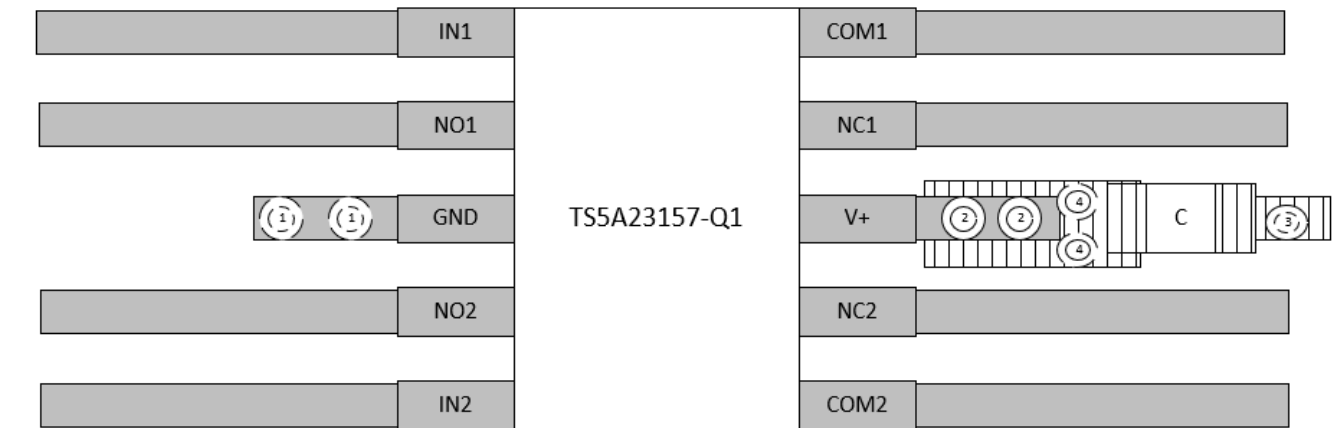
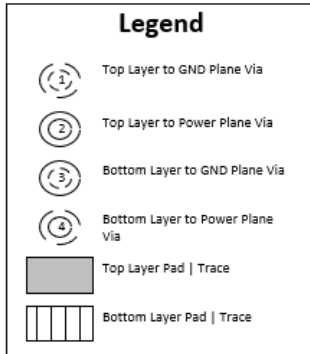
14.2 支持资源

[TI E2E™ 支持论坛](#) 是工程师的重要参考资料，可直接从专家获得快速、经过验证的解答和设计帮助。搜索现有解答或提出自己的问题可获得所需的快速设计帮助。

链接的内容由各个贡献者“按原样”提供。这些内容并不构成 TI 技术规范，并且不一定反映 TI 的观点；请参阅 TI 的《[使用条款](#)》。

14.3 Trademarks

TI E2E™ is a trademark of Texas Instruments.

所有商标均为其各自所有者的财产。

14.4 Electrostatic Discharge Caution



This integrated circuit can be damaged by ESD. Texas Instruments recommends that all integrated circuits be handled with appropriate precautions. Failure to observe proper handling and installation procedures can cause damage.

ESD damage can range from subtle performance degradation to complete device failure. Precision integrated circuits may be more susceptible to damage because very small parametric changes could cause the device not to meet its published specifications.

14.5 Glossary

[TI Glossary](#) This glossary lists and explains terms, acronyms, and definitions.

15 Mechanical, Packaging, and Orderable Information

The following pages include mechanical, packaging, and orderable information. This information is the most current data available for the designated devices. This data is subject to change without notice and revision of this document. For browser-based versions of this data sheet, refer to the left-hand navigation.

15.1 Ordering Information

T _A	PACKAGE		ORDERABLE PART NUMBER	TOP-SIDE MARKING
- 40°C to 105°C	VSSOP 10 - (DGS)	Tape and reel	TS5A23157TDGSRQ1	JBR
- 40°C to 125°C	VSSOP 10 - (DGS)	Tape and reel	TS5A23157QDGSRQ1	SJC

重要声明和免责声明

TI 提供技术和可靠性数据 (包括数据表)、设计资源 (包括参考设计)、应用或其他设计建议、网络工具、安全信息和其他资源, 不保证没有瑕疵且不做任何明示或暗示的担保, 包括但不限于对适销性、某特定用途方面的适用性或不侵犯任何第三方知识产权的暗示担保。

这些资源可供使用 TI 产品进行设计的熟练开发人员使用。您将自行承担以下全部责任: (1) 针对您的应用选择合适的 TI 产品, (2) 设计、验证并测试您的应用, (3) 确保您的应用满足相应标准以及任何其他安全、安保或其他要求。这些资源如有变更, 恕不另行通知。TI 授权您仅可将这些资源用于研发本资源所述的 TI 产品的应用。严禁对这些资源进行其他复制或展示。您无权使用任何其他 TI 知识产权或任何第三方知识产权。您应全额赔偿因在这些资源的使用中对 TI 及其代表造成的任何索赔、损害、成本、损失和债务, TI 对此概不负责。

TI 提供的产品受 TI 的销售条款 (<https://www.ti.com/legal/termsofsale.html>) 或 [ti.com](https://www.ti.com) 上其他适用条款/TI 产品随附的其他适用条款的约束。TI 提供这些资源并不会扩展或以其他方式更改 TI 针对 TI 产品发布的适用的担保或担保免责声明。

邮寄地址: Texas Instruments, Post Office Box 655303, Dallas, Texas 75265
Copyright © 2021, 德州仪器 (TI) 公司

PACKAGING INFORMATION

Orderable Device	Status (1)	Package Type	Package Drawing	Pins	Package Qty	Eco Plan (2)	Lead finish/ Ball material (6)	MSL Peak Temp (3)	Op Temp (°C)	Device Marking (4/5)	Samples
TS5A23157QDGSRQ1	ACTIVE	VSSOP	DGS	10	2500	RoHS & Green	NIPDAU	Level-3-260C-168 HR	-40 to 125	SJC	Samples
TS5A23157TDGSRQ1	ACTIVE	VSSOP	DGS	10	2500	RoHS & Green	NIPDAU	Level-3-260C-168 HR	-40 to 105	JBR	Samples

(1) The marketing status values are defined as follows:

ACTIVE: Product device recommended for new designs.

LIFEBUY: TI has announced that the device will be discontinued, and a lifetime-buy period is in effect.

NRND: Not recommended for new designs. Device is in production to support existing customers, but TI does not recommend using this part in a new design.

PREVIEW: Device has been announced but is not in production. Samples may or may not be available.

OBSOLETE: TI has discontinued the production of the device.

(2) **RoHS:** TI defines "RoHS" to mean semiconductor products that are compliant with the current EU RoHS requirements for all 10 RoHS substances, including the requirement that RoHS substance do not exceed 0.1% by weight in homogeneous materials. Where designed to be soldered at high temperatures, "RoHS" products are suitable for use in specified lead-free processes. TI may reference these types of products as "Pb-Free".

RoHS Exempt: TI defines "RoHS Exempt" to mean products that contain lead but are compliant with EU RoHS pursuant to a specific EU RoHS exemption.

Green: TI defines "Green" to mean the content of Chlorine (Cl) and Bromine (Br) based flame retardants meet JS709B low halogen requirements of <=1000ppm threshold. Antimony trioxide based flame retardants must also meet the <=1000ppm threshold requirement.

(3) MSL, Peak Temp. - The Moisture Sensitivity Level rating according to the JEDEC industry standard classifications, and peak solder temperature.

(4) There may be additional marking, which relates to the logo, the lot trace code information, or the environmental category on the device.

(5) Multiple Device Markings will be inside parentheses. Only one Device Marking contained in parentheses and separated by a "~" will appear on a device. If a line is indented then it is a continuation of the previous line and the two combined represent the entire Device Marking for that device.

(6) Lead finish/Ball material - Orderable Devices may have multiple material finish options. Finish options are separated by a vertical ruled line. Lead finish/Ball material values may wrap to two lines if the finish value exceeds the maximum column width.

Important Information and Disclaimer:The information provided on this page represents TI's knowledge and belief as of the date that it is provided. TI bases its knowledge and belief on information provided by third parties, and makes no representation or warranty as to the accuracy of such information. Efforts are underway to better integrate information from third parties. TI has taken and continues to take reasonable steps to provide representative and accurate information but may not have conducted destructive testing or chemical analysis on incoming materials and chemicals. TI and TI suppliers consider certain information to be proprietary, and thus CAS numbers and other limited information may not be available for release.

In no event shall TI's liability arising out of such information exceed the total purchase price of the TI part(s) at issue in this document sold by TI to Customer on an annual basis.

OTHER QUALIFIED VERSIONS OF TS5A23157-Q1 :

- Catalog : [TS5A23157](#)

NOTE: Qualified Version Definitions:

- Catalog - TI's standard catalog product

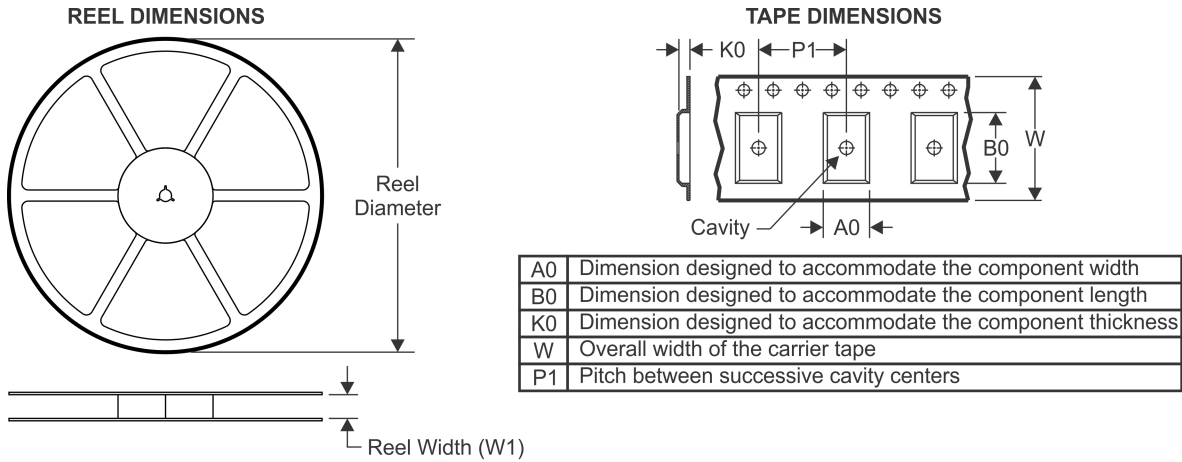
TAPE AND REEL INFORMATION

QUADRANT ASSIGNMENTS FOR PIN 1 ORIENTATION IN TAPE

*All dimensions are nominal

Device	Package Type	Package Drawing	Pins	SPQ	Reel Diameter (mm)	Reel Width W1 (mm)	A0 (mm)	B0 (mm)	K0 (mm)	P1 (mm)	W (mm)	Pin1 Quadrant
TS5A23157QDGSRQ1	VSSOP	DGS	10	2500	330.0	12.4	5.3	3.4	1.4	8.0	12.0	Q1
TS5A23157TDGSRQ1	VSSOP	DGS	10	2500	330.0	12.4	5.3	3.4	1.4	8.0	12.0	Q1

TAPE AND REEL BOX DIMENSIONS

*All dimensions are nominal

Device	Package Type	Package Drawing	Pins	SPQ	Length (mm)	Width (mm)	Height (mm)
TS5A23157QDGSRQ1	VSSOP	DGS	10	2500	346.0	346.0	29.0
TS5A23157TDGSRQ1	VSSOP	DGS	10	2500	346.0	346.0	29.0

DGS0010A



PACKAGE OUTLINE

VSSOP - 1.1 mm max height

SMALL OUTLINE PACKAGE



4221984/A 05/2015

NOTES:

1. All linear dimensions are in millimeters. Any dimensions in parenthesis are for reference only. Dimensioning and tolerancing per ASME Y14.5M.
2. This drawing is subject to change without notice.
3. This dimension does not include mold flash, protrusions, or gate burrs. Mold flash, protrusions, or gate burrs shall not exceed 0.15 mm per side.
4. This dimension does not include interlead flash. Interlead flash shall not exceed 0.25 mm per side.
5. Reference JEDEC registration MO-187, variation BA.

EXAMPLE BOARD LAYOUT

DGS0010A

VSSOP - 1.1 mm max height

SMALL OUTLINE PACKAGE



LAND PATTERN EXAMPLE
SCALE:10X



SOLDER MASK DETAILS
NOT TO SCALE

4221984/A 05/2015

NOTES: (continued)

- 6. Publication IPC-7351 may have alternate designs.
- 7. Solder mask tolerances between and around signal pads can vary based on board fabrication site.

EXAMPLE STENCIL DESIGN

DGS0010A

VSSOP - 1.1 mm max height

SMALL OUTLINE PACKAGE



SOLDER PASTE EXAMPLE
BASED ON 0.125 mm THICK STENCIL
SCALE:10X

4221984/A 05/2015

NOTES: (continued)

8. Laser cutting apertures with trapezoidal walls and rounded corners may offer better paste release. IPC-7525 may have alternate design recommendations.
9. Board assembly site may have different recommendations for stencil design.

重要声明和免责声明

TI 提供技术和可靠性数据（包括数据表）、设计资源（包括参考设计）、应用或其他设计建议、网络工具、安全信息和其他资源，不保证没有瑕疵且不做任何明示或暗示的担保，包括但不限于对适销性、某特定用途方面的适用性或不侵犯任何第三方知识产权的暗示担保。

这些资源可供使用 TI 产品进行设计的熟练开发人员使用。您将自行承担以下全部责任：(1) 针对您的应用选择合适的 TI 产品，(2) 设计、验证并测试您的应用，(3) 确保您的应用满足相应标准以及任何其他安全、安保或其他要求。这些资源如有变更，恕不另行通知。TI 授权您仅可将这些资源用于研发本资源所述的 TI 产品的应用。严禁对这些资源进行其他复制或展示。您无权使用任何其他 TI 知识产权或任何第三方知识产权。您应全额赔偿因在这些资源的使用中对 TI 及其代表造成的任何索赔、损害、成本、损失和债务，TI 对此概不负责。

TI 提供的产品受 TI 的销售条款 (<https://www.ti.com.cn/zh-cn/legal/termsofsale.html>) 或 [ti.com.cn](https://www.ti.com.cn) 上其他适用条款/TI 产品随附的其他适用条款的约束。TI 提供这些资源并不会扩展或以其他方式更改 TI 针对 TI 产品发布的适用的担保或担保免责声明。

邮寄地址：上海市浦东新区世纪大道 1568 号中建大厦 32 楼，邮政编码：200122

Copyright © 2021 德州仪器半导体技术（上海）有限公司