

TPS63025x 高电流、高效单电感器降压-升压转换器

1 特性

- 支持降压和升压运行间自动和无缝转换的实际降压或升压运行
- 输入电压范围 2.3V 至 5.5V
- 2A 持续输出电流: $V_{IN} \geq 2.7V$, $V_{OUT} = 3.3V$
- 可调和固定输出电压
- 在降压或升压模式中效率高达 95%，而在 $V_{IN} = V_{OUT}$ 时，效率高达 97%
- 2.5MHz 典型开关频率
- 运行静态电流 35 μ A
- 集成软启动
- 省电模式
- 真正关断功能
- 输出电容器放电功能
- 过热保护和过流保护
- 宽电容值选择
- 小型 1.766mm x 2.086mm, 20 引脚晶圆级芯片尺寸 (WCSP) 封装

2 应用范围

- 手机、智能电话
- 平板个人电脑
- 个人电脑和智能手机配件
- 负载点稳压
- 电池供电类应用

4 典型应用

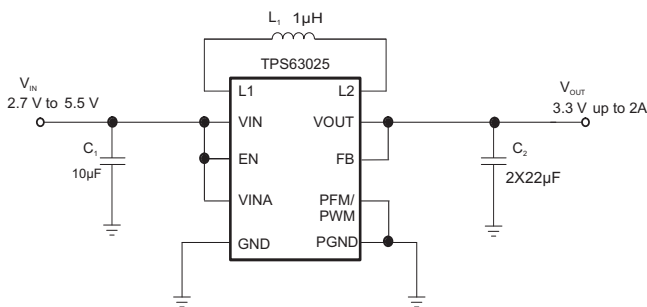

3 说明

TPS63025 是一款高效、低静态电流降压-升压转换器，此转换器适用于输入电压会高于或低于输出的应用。输出电流在升压模式中会高达 2A，而在降压模式中会高达 4A。开关内的最大平均电流被限制在 4A（典型值）。TPS63025 根据输入电压在降压或升压模式之间自动切换，以便在整个输入电压范围内调节输出电压，从而确保两个模式间的无缝转换。此降压-升压转换器基于一个使用同步整流的固定频率、脉宽调制 (PWM) 控制器以获得最高效率。在低负载电流情况下，此转换器进入省电模式，以便在整个负载电流范围内保持高效率。有一个使用户能够在自动 PFM/PWM 模式运行和强制 PWM 运行之间进行选择的 PFM/PWM 引脚。在 PWM 模式期间，通常使用一个 2.5MHz 的固定频率。使用一个外部电阻分压器可对输出电压进行编程，或者在芯片上对输出电压进行内部固定。转换器可被禁用以最大限度地减少电池消耗。在关断期间，负载从电池上断开。此器件采用 20 引脚，1.766mm x 2.086 mm, WCSP 封装。

器件信息(1)

产品型号	封装	封装尺寸 (标称值)
TPS630250	芯片尺寸球状引脚 栅格阵列 (DSBGA) (20)	1.766mm x 2.086mm
TPS630251		
TPS630252		

(1) 要了解所有可用封装，请见数据表末尾的可订购产品附录。

效率与输出电流间的关系

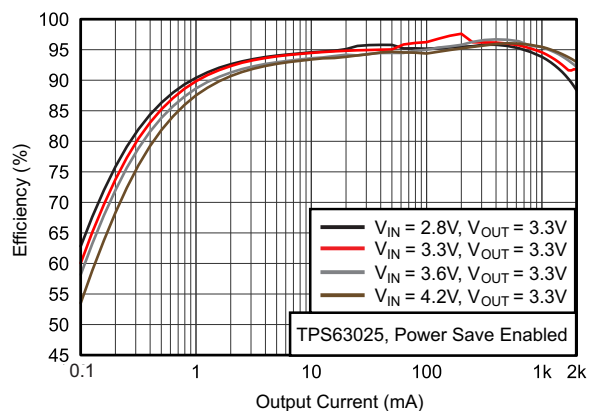

目录

1	特性	1	9.3	Feature Description.....	11
2	应用范围.....	1	9.4	Device Functional Modes.....	14
3	说明	1	10	Application and Implementation.....	15
4	典型应用.....	1	10.1	Application Information.....	15
5	修订历史记录	2	10.2	Typical Application	15
6	Device Comparison Table.....	3	11	Power Supply Recommendations	20
7	Pin Configuration and Functions	3	12	Layout.....	20
8	Specifications.....	4	12.1	Layout Guidelines	20
8.1	Absolute Maximum Ratings	4	12.2	Layout Example	20
8.2	Handling Ratings	4	12.3	Thermal Information.....	20
8.3	Recommended Operating Conditions.....	4	13	器件和文档支持	21
8.4	Thermal Information	4	13.1	器件支持	21
8.5	Electrical Characteristics.....	5	13.2	文档支持	21
8.6	Timing Requirements.....	6	13.3	相关链接.....	21
8.7	Typical Characteristics.....	7	13.4	Trademarks	21
9	Detailed Description	10	13.5	Electrostatic Discharge Caution.....	21
9.1	Overview	10	13.6	Glossary	21
9.2	Functional Block Diagram	10	14	机械封装和可订购信息	21

5 修订历史记录

Changes from Original (May 2014) to Revision A	Page
• 已将标题的产品型号从 TPS63025 改为 TPS630250, TPS630251, TPS630252	1
• Changed Load Regulation Typ spec from "125 mV/A" to "2.5 mV/A"	5

6 Device Comparison Table

PART NUMBER ⁽¹⁾	VOUT
TPS630250YFF	Adjustable
TPS630251YFF	2.9V
TPS630252YFF	3.3V

(1) For all available packages, see the orderable addendum at the end of the datasheet.

7 Pin Configuration and Functions

**WCSP
20-Pin
YFF**

(TOP VIEW)

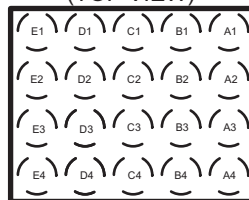

Pin Functions

PIN		I/O	DESCRIPTION
NAME	NO.		
VOUT	A1,A2,A3	PWR	Buck-boost converter output
FB	A4	IN	Voltage feedback of adjustable version, must be connected to VOUT on fixed output voltage versions
L2	B1,B2,B3	PWR	Connection for Inductor
PFM/PWM	B4	IN	set low for PFM mode, set high for forced PWM mode. It must not be left floating
PGND	C1,C2,C3	PWR	Ground for Power stage
GND	C4	PWR	Ground for Control stage
L1	D1,D2,D3	PWR	Connection for Inductor
EN	D4	IN	Enable input. Set high to enable and low to disable. It must not be left floating.
VIN	E1,E2,E3	PWR	Supply voltage for power stage
VINA	E4	PWR	Supply voltage for control stage.

8 Specifications

8.1 Absolute Maximum Ratings⁽¹⁾

over operating free-air temperature range (unless otherwise noted)

		VALUE		UNIT
		MIN	MAX	
Voltage ⁽²⁾	L2 ⁽³⁾ , VOUT, FB	-0.3	4	V
	VIN, L1 ⁽³⁾ , EN, VINA, PFM/PWM	-0.3	7	V
Input current	Continuous average current into L1 ⁽⁴⁾		2.7	A
Operating junction temperature, T _J		-40	125	°C

- (1) Stresses beyond those listed under *Absolute Maximum Ratings* may cause permanent damage to the device. These are stress ratings only, which do not imply functional operation of the device at these or any other conditions beyond those indicated under *Recommended Operating Conditions*. Exposure to absolute-maximum-rated conditions for extended periods may affect device reliability.
- (2) All voltages are DC-voltages with respect to ground terminal.
- (3) L2, L1 voltage can exceed Absolute Maximum ratings during normal operation. As long as the device is operated within recommend operating conditions device reliability is not affected.
- (4) Maximum continuous average input current 3.5A, under those condition do not exceed 105°C for more than 25% operating time.

8.2 Handling Ratings

		MIN	MAX	UNIT	
T _{stg}	Storage temperature range	-65	150	°C	
V _(ESD)	Electrostatic discharge	Human body model (HBM), per ANSI/ESDA/JEDEC JS-001, all pins ⁽¹⁾	0	2000	V
		Charged device model (CDM), per JEDEC specification JESD22-C101, all pins ⁽²⁾	0	700	

- (1) JEDEC document JEP155 states that 500-V HBM allows safe manufacturing with a standard ESD control process.
- (2) JEDEC document JEP157 states that 250-V CDM allows safe manufacturing with a standard ESD control process.

8.3 Recommended Operating Conditions⁽¹⁾

		MIN	TYP	MAX	UNIT
VIN	Input Voltage Range	2.3		5.5	V
VOUT	Output Voltage	2.3		3.6	V
L	Inductance ⁽²⁾	0.5	1	1.3	μH
C _{out}	Output Capacitance ⁽³⁾	20			μF
T _A	Operating ambient temperature	-40		85	°C
T _J	Operating virtual junction temperature	-40		125	°C

- (1) Refer to the Application Information section for further information
- (2) Effective inductance value at operating condition. The nominal value given matches a typical inductor to be chosen to meet the inductance required.
- (3) Due to the dc bias effect of ceramic capacitors, the effective capacitance is lower then the nominal value when a voltage is applied. This is why the capacitance is specified to allow the selection of the nominal capacitor required with the dc bias effect for this type of cap. The nominal value given matches a typical capacitor to be chosen to meet the minimum capacitance required.

8.4 Thermal Information

THERMAL METRIC ⁽¹⁾		TPS63025x YFF 20 PINS	UNIT
R _{θJA}	Junction-to-ambient thermal resistance	53.8	°C/W
R _{θJC(top)}	Junction-to-case (top) thermal resistance	0.5	
R _{θJB}	Junction-to-board thermal resistance	10.1	
Ψ _{JT}	Junction-to-top characterization parameter	1.4	
Ψ _{JB}	Junction-to-board characterization parameter	9.8	
R _{θJC(bot)}	Junction-to-case (bottom) thermal resistance	N/A	

- (1) For more information about traditional and new thermal metrics, see the *IC Package Thermal Metrics* application report, [SPRA953](#).

8.5 Electrical Characteristics

$T_J = -40^\circ\text{C}$ to 125°C , typical values are at $T_A = 25^\circ\text{C}$ (unless otherwise noted)

PARAMETER		TEST CONDITIONS	MIN	TYP	MAX	UNIT
SUPPLY						
V_{IN}	Input voltage range		2.3		5.5	V
V_{IN_Min}	Minimum input voltage to turn on into full load	$I_{OUT}=2A$		2.8		V
I_{OUT}	Continuous Output Current ⁽¹⁾			2		A
I_Q	Quiescent current	V_{IN}	$I_{OUT}=0mA$, $EN=V_{IN}=3.6V$, $V_{OUT}=3.3V$ $T_J=-40^\circ\text{C}$ to 85°C , not switching	35	70	μA
		V_{OUT}			12	μA
I_{sd}	Shutdown current	$EN=low$, $T_J=-40^\circ\text{C}$ to 85°C		0.1	2	μA
UVLO	Under voltage lockout threshold	V_{IN} falling	1.6	1.7	1.9	V
	Under voltage lockout hysteresis			180		mV
	Thermal shutdown	Temperature rising		140		$^\circ\text{C}$
	Thermal Shutdown hysteresis			20		$^\circ\text{C}$
LOGIC SIGNALS EN, PFM/PWM						
V_{IH}	High level input voltage	$V_{IN}=2.3V$ to $5.5V$	1.2			V
V_{IL}	Low level input voltage	$V_{IN}=2.3V$ to $5.5V$			0.4	V
I_{ikg}	Input leakage current	$EN=GND$ or V_{IN}		0.01	0.2	μA
OUTPUT						
V_{OUT}	Output Voltage range		2.3		3.6	V
V_{FB}	TPS630250 Feedback regulation voltage			0.8		V
V_{FB}	TPS630250 Feedback voltage accuracy ⁽²⁾	PWM mode	-1%		1%	
V_{FB}	TPS630250 Feedback voltage accuracy ⁽²⁾	PFM mode	-1%	1.3%	+3%	
V_{OUT}	TPS630251 Output voltage accuracy ⁽²⁾	PWM mode	2.871	2.9	2.929	V
V_{OUT}	TPS630251 Output voltage accuracy ⁽²⁾	PFM mode	2.871	2.938	2.987	V
V_{OUT}	TPS630252 Output voltage accuracy ⁽²⁾	PWM mode	3.267	3.3	3.333	V
V_{OUT}	TPS630252 Output voltage accuracy ⁽²⁾	PFM mode	3.267	3.343	3.399	V
$I_{PWM/PFM}$	Output current to enter PFM mode	$V_{IN}=3V$; $V_{OUT}=3.3V$		350		mA
I_{FB}	Feedback input bias current	$V_{FB}=0.8V$		10	100	nA
$R_{DS_Buck(on)}$	High side FET on-resistance	$V_{IN}=3.0V$, $V_{OUT}=3.3V$		35		m Ω
	Low side FET on-resistance	$V_{IN}=3.0V$, $V_{OUT}=3.3V$		50		m Ω
$R_{DS_Boost(on)}$	High side FET on-resistance	$V_{IN}=3.0V$, $V_{OUT}=3.3V$		25		m Ω
	Low side FET on-resistance	$V_{IN}=3.0V$, $V_{OUT}=3.3V$		50		m Ω
I_{IN}	Average input current limit ⁽³⁾	$V_{IN}=3.0V$, $V_{OUT}=3.3V$ $T_J=65^\circ\text{C}$ to 125°C	3.5	4.5	5	A
f_s	Switching Frequency			2.5		MHz
R_{ON_DISC}	Discharge ON-Resistance	$EN=low$		120		Ω
	Line regulation	$V_{IN}=2.8V$ to $5.5V$, $I_{OUT}=2A$		7.4		mV/ V
	Load regulation	$V_{IN}=3.6V$, $I_{OUT}=0A$ to $2A$		2.5		mV/ A

(1) For minimum and maximum output current in a specific working point see Figure 1 and Equation 1 through Equation 4.

(2) Conditions: $L=1\ \mu\text{H}$, $C_{OUT}=2 \times 22\ \mu\text{F}$.

(3) For variation of this parameter with Input voltage and temperature see Figure 1.

8.6 Timing Requirements

$T_J = -40^{\circ}\text{C}$ to 125°C , typical values are at $T_A = 25^{\circ}\text{C}$ (unless otherwise noted)

PARAMETER		TEST CONDITIONS	MIN	TYP	MAX	UNIT
OUTPUT						
t_{SS}	Soft-start time	$V_{OUT}=EN=\text{low to high, Buck mode } V_{IN}=3.6\text{V, } V_{OUT}=3.3\text{V, } I_{OUT}=2\text{A}$		450		μs
		$V_{OUT}=EN=\text{low to high, Boost mode } V_{IN}=2.8\text{V, } V_{OUT}=3.3\text{V, } I_{OUT}=2\text{A}$		700		μs
t_d	Start up delay	Time from when EN=high to when device starts switching		100		μs

8.7 Typical Characteristics

Table 1. Table Of Graphs

DESCRIPTION		FIGURE
Minimum average input current	vs Input voltage (TPS63025, $V_{OUT} = 3.3V$)	Figure 1
Efficiency	vs Output current (TPS63025, Power Save Enabled, $V_{OUT} = 3.3V$)	Figure 2
	vs Output current (TPS63025, Power Save Disabled, $V_{OUT} = 3.3V$)	Figure 3
	vs Output current (TPS63025, Power Save Enabled, $V_{OUT} = 2.9V$)	Figure 4
	vs Output current (TPS63025, Power Save Disabled, $V_{OUT} = 2.9V$)	Figure 5
	vs Input voltage (TPS63025, Power Save Enabled, $V_{OUT} = 3.3V$, $I_{OUT} = \{10mA; 20mA; 1A; 2A\}$)	Figure 6
	vs Input voltage (TPS63025, Power Save Disabled, $V_{OUT} = 3.3V$, $I_{OUT} = \{10mA; 20mA; 1A; 2A\}$)	Figure 7
	vs Input voltage (TPS63025, Power Save Enabled, $V_{OUT} = 2.9V$, $I_{OUT} = \{10mA; 20mA; 1A; 2A\}$)	Figure 8
	vs Input voltage (TPS63025, Power Save Disabled, $V_{OUT} = 2.9V$, $I_{OUT} = \{10mA; 20mA; 1A; 2A\}$)	Figure 9
Output voltage	vs Output current (TPS63025, $V_{IN} = 2.8V, 3.3V, 3.6V, 4.2V$, $V_{OUT} = 3.3V$)	Figure 10
	vs Output current (TPS63025, $V_{IN} = 2.8V, 3.3V, 3.6V, 4.2V$, $V_{OUT} = 3.3V$)	Figure 11

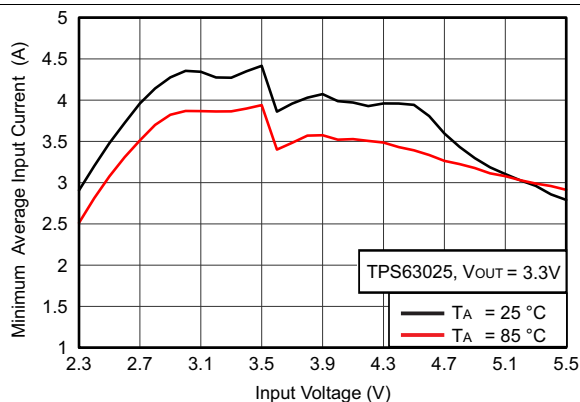

Figure 1. Minimum Average Input Current vs Input Voltage

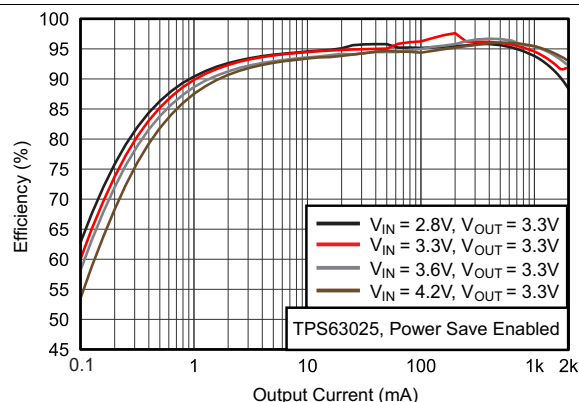

Figure 2. Efficiency vs Output Current

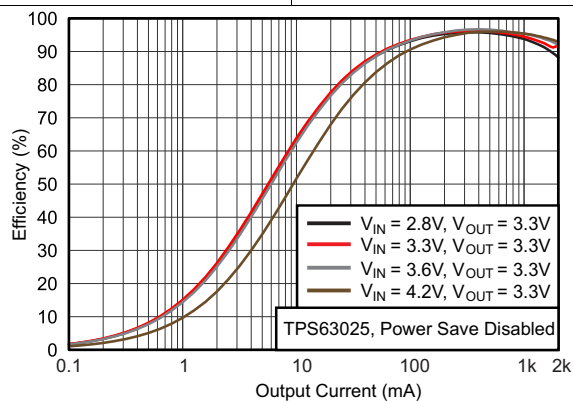

Figure 3. Efficiency vs Output Current

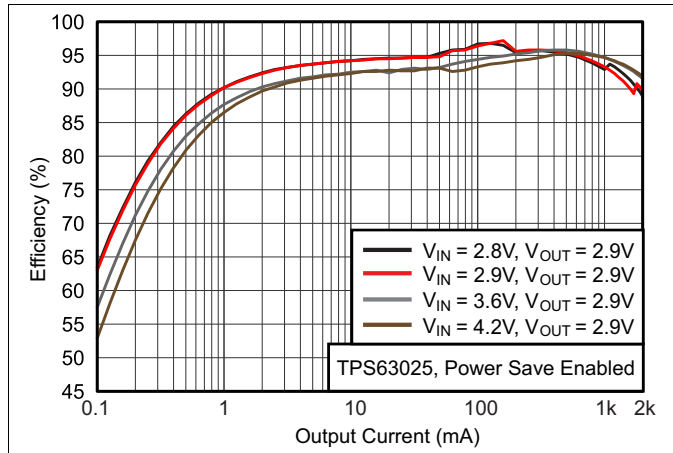

Figure 4. Efficiency vs Output Current

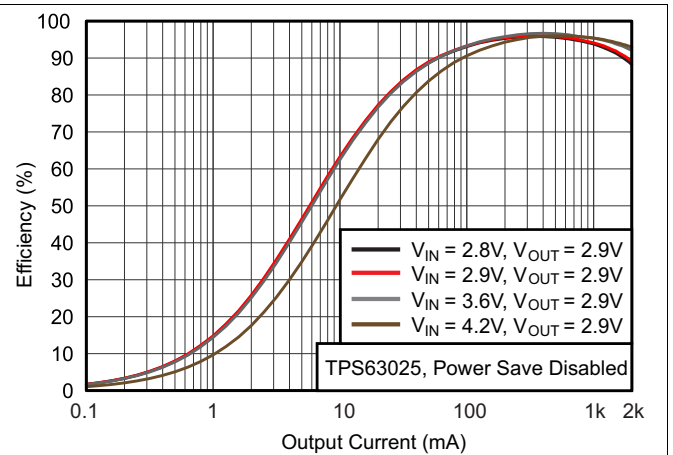

Figure 5. Efficiency vs Output Current

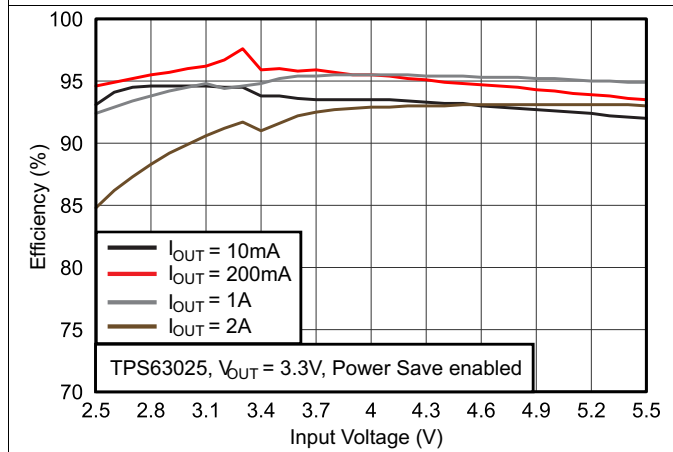

Figure 6. Efficiency vs Input Voltage

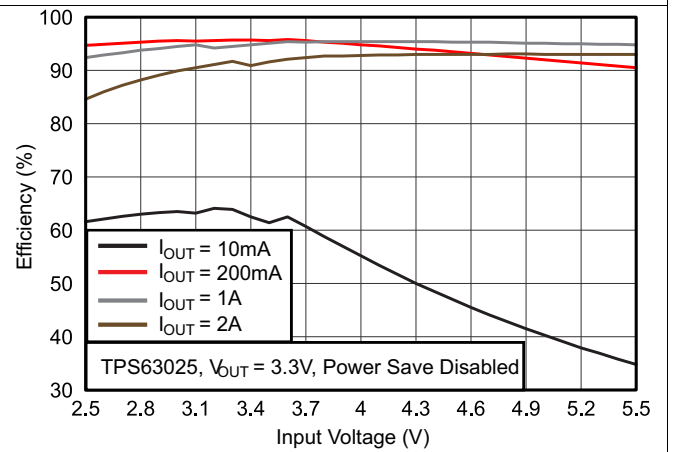

Figure 7. Efficiency vs Input Voltage

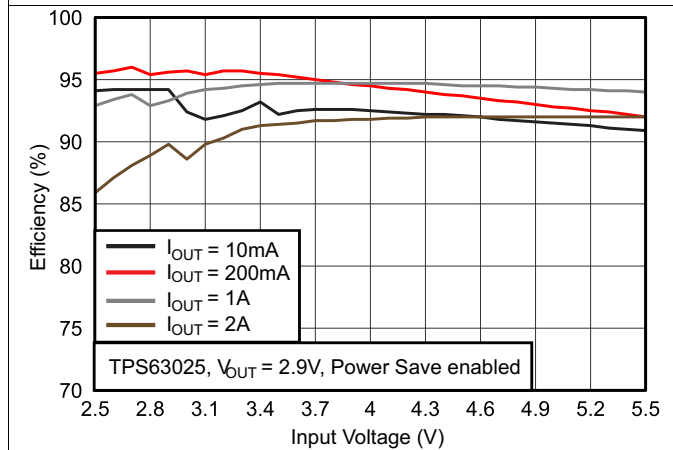

Figure 8. Efficiency vs Input Voltage

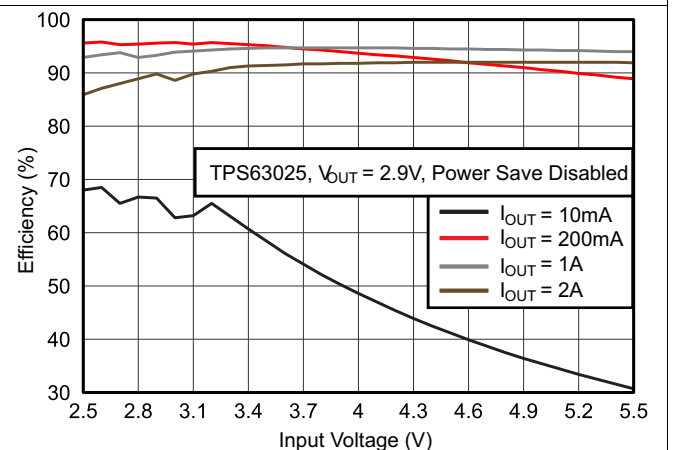

Figure 9. Efficiency vs Input Voltage

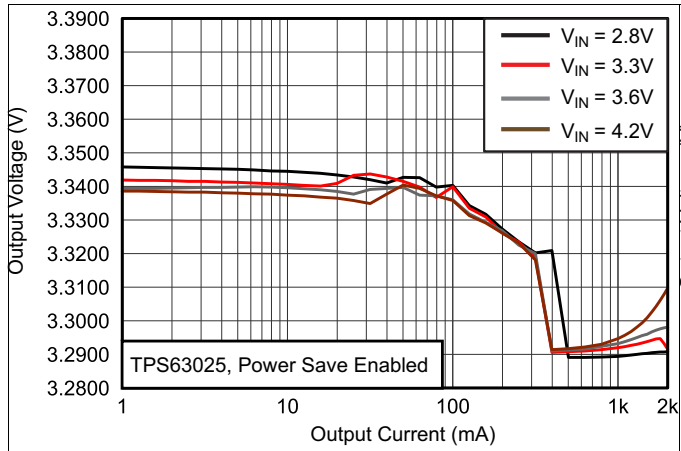

Figure 10. Output Voltage vs Output Current

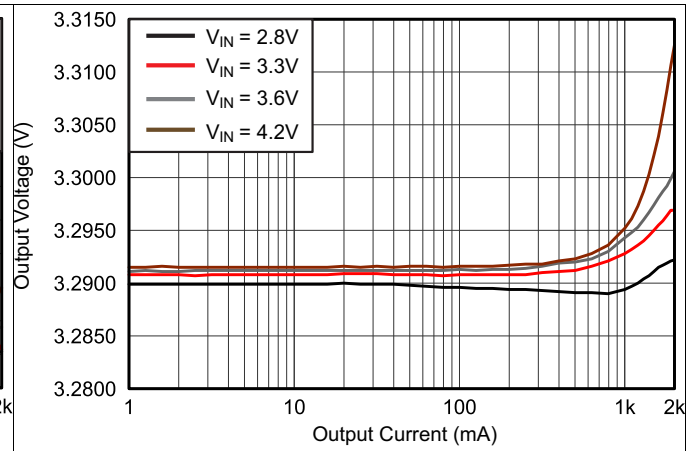
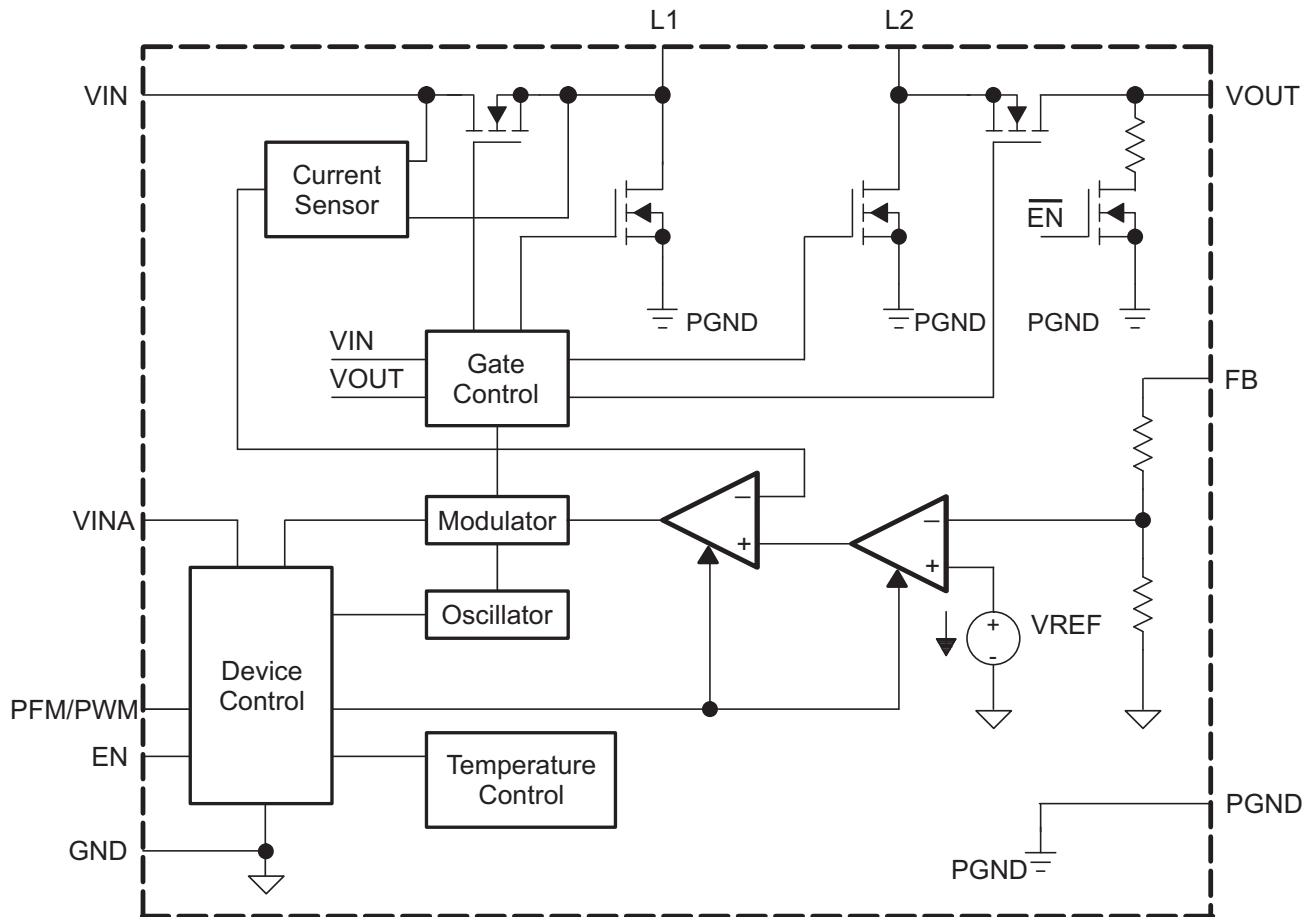

Figure 11. Output Voltage vs Output Current

Functional Block Diagram (continued)



Functional Block Diagram (Fixed Output Voltage)

9.3 Feature Description

9.3.1 Control Loop Description

The controller circuit of the device is based on an average current mode topology. The average inductor current is regulated by a fast current regulator loop which is controlled by a voltage control loop. Figure 12 shows the control loop.

The non inverting input of the transconductance amplifier, G_{mv} , is assumed to be constant. The output of G_{mv} defines the average inductor current. The inductor current is reconstructed by measuring the current through the high side buck MOSFET. This current corresponds exactly to the inductor current in boost mode. In buck mode the current is measured during the on time of the same MOSFET. During the off time, the current is reconstructed internally starting from the peak value reached at the end of the on time cycle. The average current is then compared to the desired value and the difference, or current error, is amplified and compared to the buck or the boost sawtooth ramp. Depending on which of the two ramps the G_{mc} amplified output crosses either the Buck MOSFETs or the Boost MOSFETs will be activated. When the input voltage is close to the output voltage, one buck cycle is always followed by a boost cycle. In this condition, no more than three cycles in a row of the same mode are allowed. This control method in the buck-boost region L2 ensures a robust control and the highest efficiency.

Feature Description (continued)

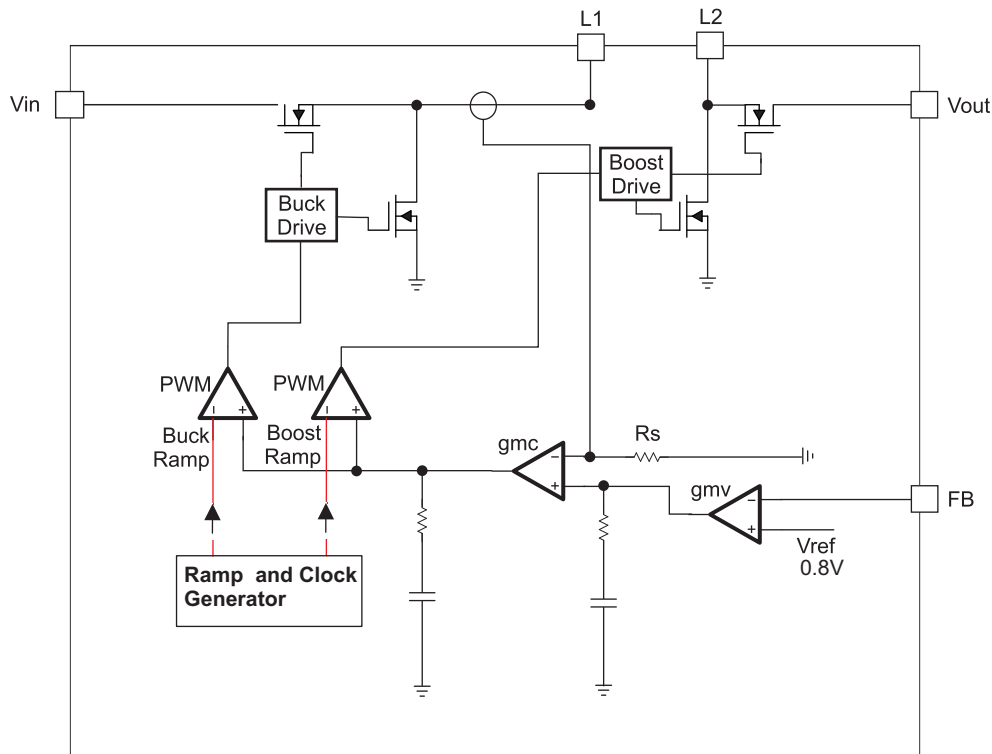

Figure 12. Average Current Mode Control

9.3.2 Device Enable

The device is put into operation when the EN pin is set high. It is put into shutdown mode when the EN pin is set low. In shutdown mode, the regulator stops switching, all internal control circuitry is switched off, and the load is disconnected from the input. This means that during shutdown, the output voltage can drop below the input voltage.

9.3.3 Output Discharge Function

When the device is disabled by pulling enable low and the supply voltage is still applied, a transistor is turned on, and discharge the output capacitor. This means, if there is no supply voltage applied the output discharge function is also disabled. The transistor which is responsible of the discharge function, when turned on, operates like an equivalent 120Ω resistor, ensuring typically less than 10ms discharge time for 20uF output capacitance and a 3.3V output.

9.3.4 Soft Start

To minimize inrush current and output voltage overshoot during start up, the device implements a soft start.

At turn on, the input current raises in a controlled manner until the output voltage reaches regulation.

During soft-start, the input current follows the current used to charge an internal soft start capacitor, this creates a linear and controlled increase of Vout.

The soft start time, is measured as the time from when the EN pin is asserted to when the output voltage has reached 90% of it's nominal value. It is typically less than 1ms. There is typically a 100μs delay time from when the EN pin is asserted to when the device starts the switching activity.

The soft start time depends on the load current, the input voltage, and the output capacitor. The soft start time in boost mode is longer then the time in buck mode.

Feature Description (continued)

Thanks to its innovative soft start circuit, the device smoothly ramps up the input current bringing the output voltage to its regulated value without overshoot, even if a large capacitor is connected at the output. This specific case is never confused with a short circuit condition. The inductor current is able to increase and always guarantee soft start unless a real short circuit is applied at the output.

9.3.5 Short Circuit Protection

The TPS63025 provides short circuit protection to protect itself and the application. When the output voltage does not increase above 1.2V, the device assumes a short circuit at the output and keeps the input current controlled to protect itself and the application. In short circuit, the input current limit is kept at 3A

9.3.6 Undervoltage Lockout

An undervoltage lockout function prevents device start-up if the supply voltage on VIN and VINA is lower than its threshold (see electrical characteristics table). When in operation, the device automatically enters shutdown mode if the voltage on VIN and VINA drops below the undervoltage lockout threshold. The device automatically restarts, if the input voltage recovers above the hysteresis amount.

9.3.7 Supply and Ground

The TPS63025 provides two input pins (VIN and VINA) and two ground pins (PGND and GND).

The VIN pin supplies the input power, while the VINA pin provides voltage for the control circuits. A similar approach is used for the ground pins. GND and PGND are used to avoid ground shift problems due to the high currents in the switches. The reference for all control functions is the GND pin. The power switches are connected to PGND. Both grounds must be connected on the PCB at only one point, ideally, close to the GND pin.

9.3.8 Overtemperature Protection

The device has a built-in temperature sensor which monitors the internal IC temperature. If the temperature exceeds the programmed threshold (see electrical characteristics table) the device stops operating. As soon as the IC temperature has decreased below the programmed threshold, it starts operating again. There is a built-in hysteresis to avoid unstable operation at IC temperatures at the overtemperature threshold.

9.3.9 Current Limit

The current limit varies depending on the difference between the input and output voltage. The maximum value of average input current is obtained at the highest difference.

Given the curves provided in Figure 1, it is possible to calculate the output current reached in boost mode, using [Equation 1](#) and [Equation 2](#) and in buck mode using [Equation 3](#) and [Equation 4](#).

$$\text{Duty Cycle Boost} \quad D = \frac{V_{\text{OUT}} - V_{\text{IN}}}{V_{\text{OUT}}} \quad (1)$$

$$\text{Output Current Boost} \quad I_{\text{OUT}} = \eta \times I_{\text{IN}}(1-D) \quad (2)$$

$$\text{Duty Cycle Buck} \quad D = \frac{V_{\text{OUT}}}{V_{\text{IN}}} \quad (3)$$

$$\text{Output Current Buck} \quad I_{\text{OUT}} = (\eta \times I_{\text{IN}}) / D \quad (4)$$

With,

η = Estimated converter efficiency (use the number from the efficiency curves or 0.90 as an assumption)

I_{IN} = Minimum average input current (Figure 1)

9.4 Device Functional Modes

9.4.1 Power Save Mode Operation

Depending on the load current, in order to provide the best efficiency over the complete load range, the device works in PWM mode at load currents of approximately 350mA or higher. At lighter loads, the device switches automatically into Power Save Mode to reduce power consumption and extend battery life. The PFM/PWM pin is used to select between the two different operation modes. To enable Power Save Mode, the PFM/PWM pin must be set low.

During Power Save Mode, the part operates with a reduced switching frequency and lowest supply current to maintain high efficiency. The output voltage is monitored with a comparator at every clock cycle by the thresholds comp low and comp high. When the device enters Power Save Mode, the converter stops operating and the output voltage drops. The slope of the output voltage depends on the load and the output capacitance. When the output voltage reaches the comp low threshold, at the next clock cycle the device ramps up the output voltage again, by starting operation. Operation can last for one or several pulses until the comp high threshold is reached. At the next clock cycle, if the load is still lower than about 350mA, the device switches off again and the same operation is repeated. Instead, if at the next clock cycle, the load is above 350mA, the device automatically switches to PWM mode.

In order to keep high efficiency in PFM mode, there is only a comparator active to keep the output voltage regulated. The AC ripple in this condition is increased, compared to the PWM mode. The amplitude of this voltage ripple in the worst case scenario is 50mV pk-pk, (typically 30mV pk-pk), with 20μF effective output capacitance. In order to avoid a critical voltage drop when switching from 0A to full load, the output voltage in PFM mode is typically 1.3% above the nominal value in PWM mode. Dynamic Voltage Positioning allows the converter to operate with a small output capacitor and still have a low absolute voltage drop during heavy load transients.

Power Save Mode is disabled by setting the PFM/PWM pin high.

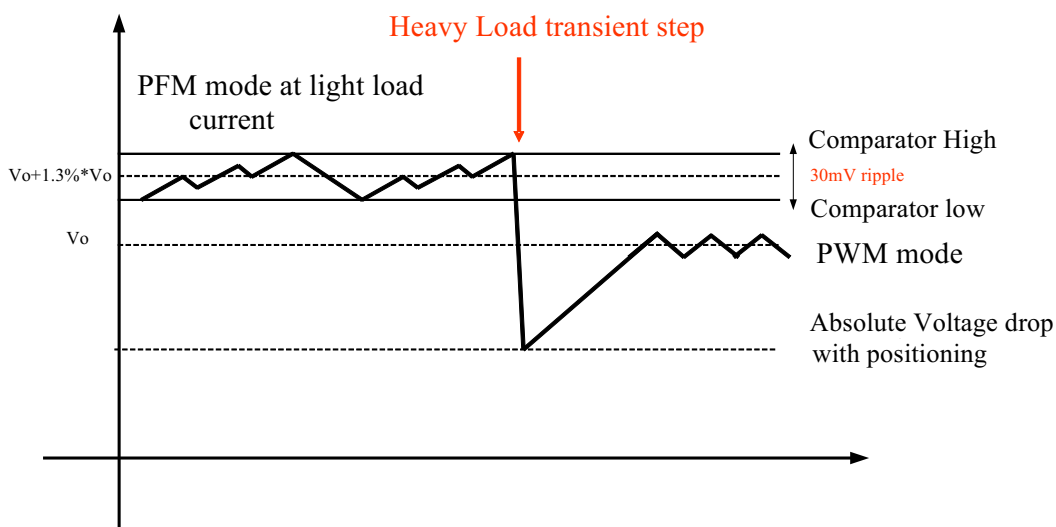

Figure 13. Power Save Mode Operation

10 Application and Implementation

10.1 Application Information

The devices are designed to operate from an input voltage supply range between 2.3V and 5.5V with a maximum output current of 2A. The TPS63025 device operates in PWM mode for medium to heavy load conditions and in power save mode at light load currents.

In PWM mode the TPS63025 converter operates with the nominal switching frequency of 2.5MHz. As the load current decreases, the converter enters power save mode, reducing the switching frequency and minimizing the IC quiescent current to achieve high efficiency over the entire load range.

10.2 Typical Application

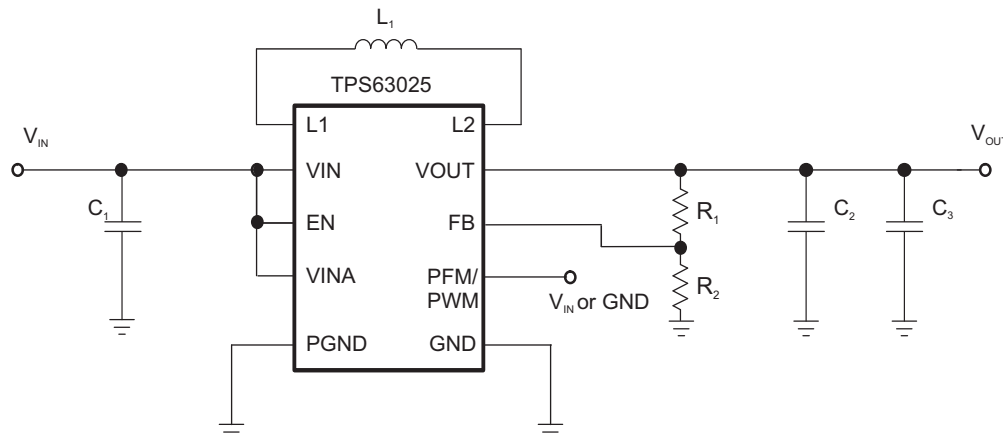

10.2.1 Design Requirements

The TPS63025 series of buck-boost converter has internal loop compensation. Therefore, the external LC filter has to be selected according to the internal compensation. Nevertheless, it's important to consider, that the effective inductance, due to inductor tolerance and current derating can vary between +20% and -30%. The same for the capacitance of the output filter: the effective capacitance can vary between +20% and -50% of the specified datasheet value, due to capacitor tolerance and bias voltage. For this reason Table 3 shows the capacitance and inductance value allowed

10.2.2 Detailed Design Procedure

Table 2. List Of Components⁽¹⁾

REFERENCE	DESCRIPTION	MANUFACTURER
	TPS63025	Texas Instruments
L1	Shielded, Composite, 1μH, 8.75A, 13mΩ, SMD	XAL4020-102MEB, Colicraft
C1,C2	10 μF 6.3V, 0603, X5R ceramic	GRM188R60J106ME84D, Murata
C3	CAP, CERM, 47μF, 6.3V, +/-20%, X5R, 0805	GRM219R60J476ME44D, Murata
R1	Depending on the output voltage at adjustable output voltage version, 0 Ω at fixed 3.3V or 2.9V	
R2	Depending on the output voltage at adjustable output voltage version, not used at fixed 3.3V or 2.9V	

(1) See [Third-Party Products Disclaimer](#)

10.2.2.1 Output Filter Design

Table 3. Matrix of Output Capacitor and Inductor Combinations

NOMINAL INDUCTOR VALUE [μH] ⁽¹⁾	NOMINAL OUTPUT CAPACITOR VALUE [μF] ⁽²⁾				
	44	47	66	88	100
0.680			+	+	+
1.0	+(3)	+	+	+	+
1.5			+	+	+

- (1) Inductor tolerance and current de-rating is anticipated. The effective inductance can vary by 20% and –30%.
 (2) Capacitance tolerance and bias voltage de-rating is anticipated. The effective capacitance can vary by 20% and –50%.
 (3) Typical application. Other check mark indicates recommended filter combinations

10.2.2.2 Inductor Selection

For high efficiencies, the inductor should have a low dc resistance to minimize conduction losses. Especially at high-switching frequencies, the core material has a high impact on efficiency. When using small chip inductors, the efficiency is reduced mainly due to higher inductor core losses. This needs to be considered when selecting the appropriate inductor. The inductor value determines the inductor ripple current. The larger the inductor value, the smaller the inductor ripple current and the lower the conduction losses of the converter. Conversely, larger inductor values cause a slower load transient response. To avoid saturation of the inductor, the peak current for the inductor in steady state operation is calculated using Equation 1. Only the equation which defines the switch current in boost mode is shown, because this provides the highest value of current and represents the critical current value for selecting the right inductor.

$$\text{Duty Cycle Boost } D = \frac{V_{\text{OUT}} - V_{\text{IN}}}{V_{\text{OUT}}} \quad (5)$$

$$I_{\text{PEAK}} = \frac{I_{\text{out}}}{\eta \times (1 - D)} + \frac{V_{\text{in}} \times D}{2 \times f \times L} \quad (6)$$

Where,

D =Duty Cycle in Boost mode

f = Converter switching frequency (typical 2.5MHz)

L = Inductor value

η = Estimated converter efficiency (use the number from the efficiency curves or 0.90 as an assumption)

Note: The calculation must be done for the minimum input voltage which is possible to have in boost mode

Calculating the maximum inductor current using the actual operating conditions gives the minimum saturation current of the inductor needed. It's recommended to choose an inductor with a saturation current 20% higher than the value calculated using Equation 6. The following inductors are recommended for use:

The inductor value also affects the stability of the feedback loop. In particular the boost transfer function exhibits a right half-plane zero, whose frequency is inverse proportional to the inductor value and the load current. This means as the inductance and load current increase, the right half plane zero decreases in frequency. This could degrade the phase margin of the feedback loop. It is recommended to choose the inductor's value in order to have the frequency of the right half plane zero >300kHz. The frequency of the RHPZ can be calculated using Equation 7.

$$f_{\text{RHPZ}} = \frac{(1 - D)^2 \times V_{\text{out}}}{2\pi \times I_{\text{out}} \times L} \quad (7)$$

With,

D =Duty Cycle in Boost mode

Note: The calculation must be done for the minimum input voltage which is possible to have in boost mode

Table 4. List of Recommended Inductors⁽¹⁾

INDUCTOR VALUE	COMPONENT SUPPLIER	SIZE (LxWxH mm)	I _{sat} /DCR
1 μH	Coilcraft XAL4020-102ME	4 X 4 X 2.10	4.5A/10mΩ
1 μH	Toko, DFE322512C	3.2 X 2.5 X 1.2	4.7A/34mΩ
1 μH	TDK, SPM4012	4.4 X 4.1 X 1.2	4.1A/38mΩ
1 μH	Wuerth, 74438334010	3 X 3 X 1.2	6.6A/42.10mΩ
0.6 μH	Coilcraft XFL4012-601ME	4 X 4 X 1.2	5A/17.40mΩ
0.68μH	Wuerth,744383340068	3 X 3 X 1.2	7.7A/36mΩ

(1) See [Third-Party Products Disclaimer](#)

10.2.2.3 Capacitor Selection

10.2.2.3.1 Input Capacitor

At least a 10μF input capacitor is recommended to improve transient behavior of the regulator and EMI behavior of the total power supply circuit. An X5R or X7R ceramic capacitor placed as close as possible to the VIN and PGND pins of the IC is recommended. This capacitance can be increased without limit.

10.2.2.3.2 Output Capacitor

For the output capacitor, use of a small ceramic capacitors placed as close as possible to the VOUT and PGND pins of the IC is recommended. The recommended nominal output capacitance value is 20μF with a variance as outlined in Table 4.

There is also no upper limit for the output capacitance value. Larger capacitors causes lower output voltage ripple as well as lower output voltage drop during load transients.

10.2.2.4 Setting The Output Voltage

When the adjustable output voltage version TPS630250 is used, the output voltage is set by an external resistor divider. The resistor divider must be connected between VOUT, FB and GND. When the output voltage is regulated properly, the typical value of the voltage at the FB pin is 800mV. The current through the resistive divider should be about 10 times greater than the current into the FB pin. The typical current into the FB pin is 0.1μA, and the voltage across the resistor between FB and GND, R₂, is typically 800 mV. Based on these two values, the recommended value for R₂ should be lower than 180kΩ, in order to set the divider current at 4μA or higher. It is recommended to keep the value for this resistor in the range of 180kΩ. From that, the value of the resistor connected between VOUT and FB, R₁, depending on the needed output voltage (V_{OUT}), can be calculated using [Equation 8](#):

$$R1 = R2 \times \left(\frac{V_{OUT}}{V_{FB}} - 1 \right) \quad (8)$$

10.2.3 Application Curves

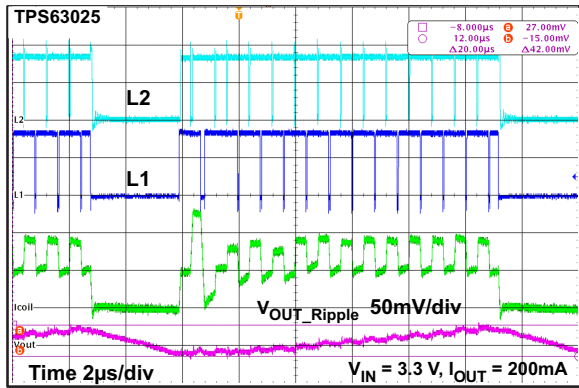

Figure 14. Output Voltage Ripple in Buck-Boost Mode and PFM to PWM Transition

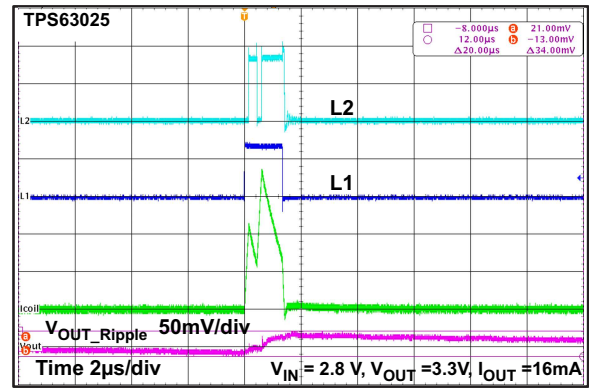

Figure 15. Output Voltage Ripple in Boost Mode and PFM to PWM Operation

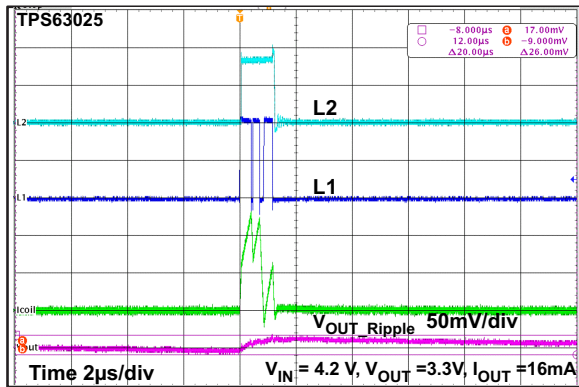

Figure 16. Output Voltage Ripple in Buck Mode and PFM Operation

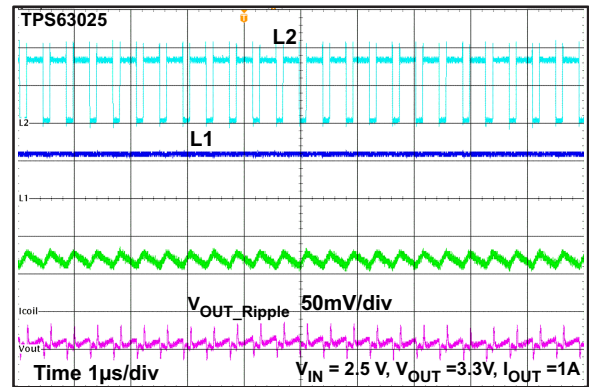

Figure 17. Switching Waveforms in Boost Mode and PWM Operation

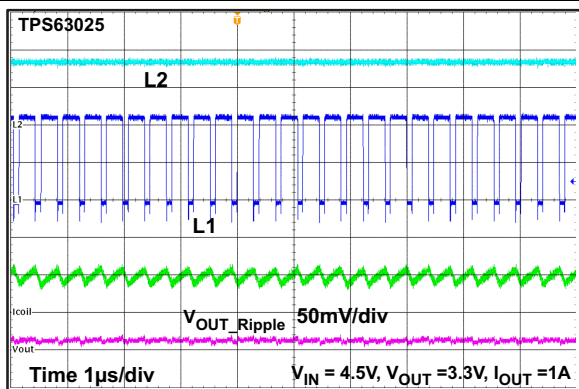

Figure 18. Switching Waveforms in Buck Mode and PWM Operation

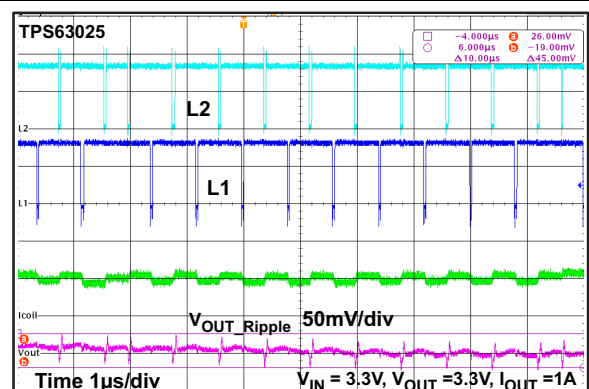

Figure 19. Switching Waveforms in Buck-Boost Mode and PWM Operation

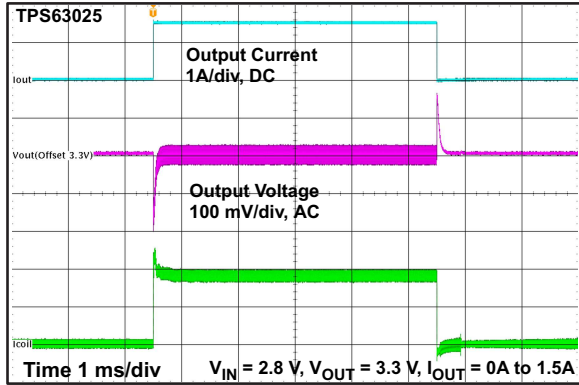

Figure 20. Load Transient Response Boost Mode

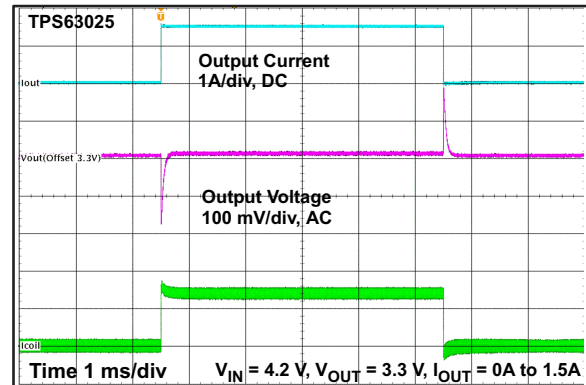

Figure 21. Load Transient Response Buck Mode

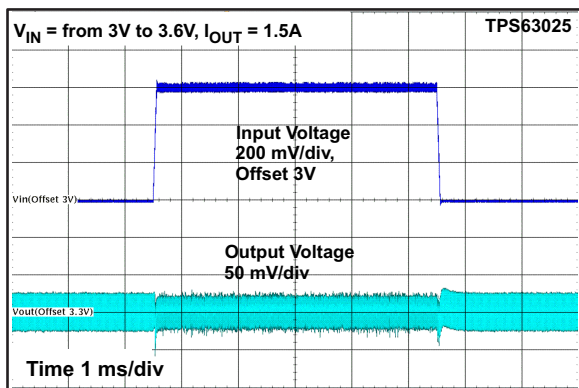

Figure 22. Line Transient Response

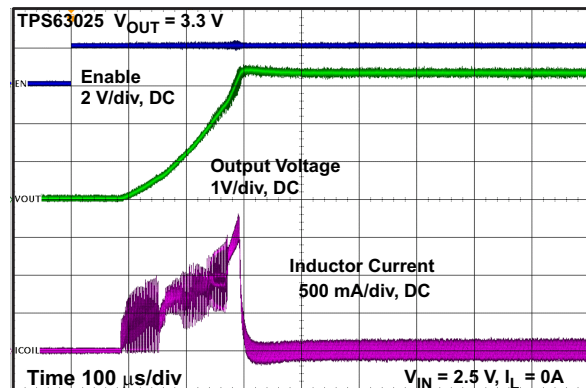

Figure 23. Start Up After Enable

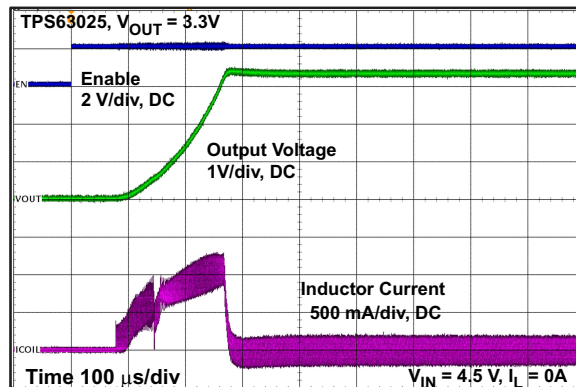

Figure 24. Start Up After Enable

11 Power Supply Recommendations

The device is designed to operate from an input voltage supply range between 2.3V and 5.5 V. This input supply must be well regulated. If the input supply is located more than a few inches from the TPS63025 converter additional bulk capacitance may be required in addition to the ceramic bypass capacitors. An electrolytic or tantalum capacitor with a value of 47 μ F is a typical choice.

12 Layout

12.1 Layout Guidelines

The PCB layout is an important step to maintain the high performance of the TPS63025 devices.

- Place input and output capacitors, along with the inductor, as close as possible to the IC which keeps the traces short. Routing these traces direct and wide results in low trace resistance and low parasitic inductance.
- Use a common-power GND.
- Properly connect the low side of the input and output capacitors to the power GND to avoid a GND potential shift.
- The sense trace connected to FB is signal trace. Keep these trace away from L1 and L2 nodes.
- Use care to avoid noise induction. By a direct routing, parasitic inductance can be kept small.
- Use GND layers for shielding if needed.

12.2 Layout Example

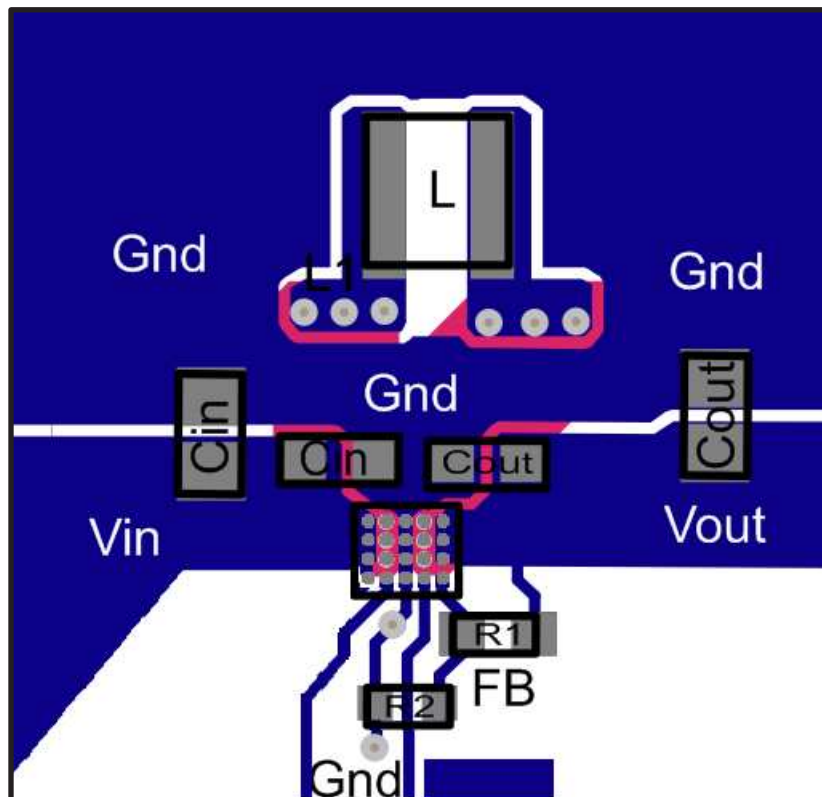

12.3 Thermal Information

Implementation of integrated circuits in low-profile and fine-pitch surface-mount packages typically requires special attention to power dissipation. Many system-dependent issues such as thermal coupling, airflow, added heat sinks and convection surfaces, and the presence of other heat-generating components affect the power-dissipation limits of a given component.

Thermal Information (continued)

Two basic approaches for enhancing thermal performance are listed below:

- Improving the power dissipation capability of the PCB design
- Introducing airflow in the system

For more details on how to use the thermal parameters, see the application notes: [Thermal Characteristics Application Note \(SZZA017\)](#), and [IC Package Thermal Metrics Application Note \(SPRA953\)](#).

13 器件和文档支持

13.1 器件支持

13.1.1 第三方产品免责声明

TI 发布的与第三方产品或服务有关的信息，不能构成与此类产品或服务或保修的适用性有关的认可，不能构成此类产品或服务单独或与任何 TI 产品或服务一起的表示或认可。

13.2 文档支持

13.2.1 相关文档

相关文档如下：

《TPS63025EVM-553 用户指南，TPS63025 高电流、高效率单电感器降压-升压转换器》，[SLVUA24](#)

13.3 相关链接

以下表格列出了快速访问链接。范围包括技术文档、支持与社区资源、工具和软件，以及样片或购买的快速访问。

Table 5. 相关链接

部件	产品文件夹	样片与购买	技术文档	工具与软件	支持与社区
TPS630250	请单击此处	请单击此处	请单击此处	请单击此处	请单击此处
TPS630251	请单击此处	请单击此处	请单击此处	请单击此处	请单击此处
TPS630252	请单击此处	请单击此处	请单击此处	请单击此处	请单击此处

13.4 Trademarks

All trademarks are the property of their respective owners.

13.5 Electrostatic Discharge Caution



These devices have limited built-in ESD protection. The leads should be shorted together or the device placed in conductive foam during storage or handling to prevent electrostatic damage to the MOS gates.

13.6 Glossary

[SLYZ022](#) — *TI Glossary*.

This glossary lists and explains terms, acronyms and definitions.

14 机械封装和可订购信息

以下页中包括机械封装和可订购信息。 这些信息是针对指定器件可提供的最新数据。 这些数据会在无通知且不对本文档进行修订的情况下发生改变。 欲获得该数据表的浏览器版本，请查阅左侧的导航栏。

重要声明

德州仪器(TI)及其下属子公司有权根据 JESD46 最新标准,对所提供的产品和服务进行更正、修改、增强、改进或其它更改,并有权根据 JESD48 最新标准中止提供任何产品和服务。客户在下订单前应获取最新的相关信息,并验证这些信息是否完整且是最新的。所有产品的销售都遵循在订单确认时所提供的TI 销售条款与条件。

TI 保证其所销售的组件的性能符合产品销售时 TI 半导体产品销售条件与条款的适用规范。仅在 TI 保证的范围内,且 TI 认为有必要时才会使用测试或其它质量控制技术。除非适用法律做出了硬性规定,否则没有必要对每种组件的所有参数进行测试。

TI 对应用帮助或客户产品设计不承担任何义务。客户应对其使用 TI 组件的产品和应用自行负责。为尽量减小与客户产品和应用相关的风险,客户应提供充分的设计与操作安全措施。

TI 不对任何 TI 专利权、版权、屏蔽作品权或其它与使用了 TI 组件或服务的组合设备、机器或流程相关的 TI 知识产权中授予的直接或隐含权限作出任何保证或解释。TI 所发布的与第三方产品或服务有关的信息,不能构成从 TI 获得使用这些产品或服务的许可、授权、或认可。使用此类信息可能需要获得第三方的专利权或其它知识产权方面的许可,或是 TI 的专利权或其它知识产权方面的许可。

对于 TI 的产品手册或数据表中 TI 信息的重要部分,仅在没有对内容进行任何篡改且带有相关授权、条件、限制和声明的情况下才允许进行复制。TI 对此类篡改过的文件不承担任何责任或义务。复制第三方的信息可能需要服从额外的限制条件。

在转售 TI 组件或服务时,如果对该组件或服务参数的陈述与 TI 标明的参数相比存在差异或虚假成分,则会失去相关 TI 组件或服务的所有明示或暗示授权,且这是不正当的、欺诈性商业行为。TI 对任何此类虚假陈述均不承担任何责任或义务。

客户认可并同意,尽管任何应用相关信息或支持仍可能由 TI 提供,但他们将独立负责满足与其产品及其在应用中使用的 TI 产品相关的所有法律、法规和安全相关要求。客户声明并同意,他们具备制定与实施安全措施所需的全部专业技术和知识,可预见故障的危险后果、监测故障及其后果、降低有可能造成人身伤害的故障的发生机率并采取适当的补救措施。客户将全额赔偿因在此类安全关键应用中使用任何 TI 组件而对 TI 及其代理造成的任何损失。

在某些场合中,为了推进安全相关应用有可能对 TI 组件进行特别的促销。TI 的目标是利用此类组件帮助客户设计和创立其特有的可满足适用的功能安全性标准和要求的终端产品解决方案。尽管如此,此类组件仍然服从这些条款。

TI 组件未获得用于 FDA Class III (或类似的生命攸关医疗设备)的授权许可,除非各方授权官员已经达成了专门管控此类使用的特别协议。

只有那些 TI 特别注明属于军用等级或“增强型塑料”的 TI 组件才是设计或专门用于军事/航空应用或环境的。购买者认可并同意,对并非指定面向军事或航空航天用途的 TI 组件进行军事或航空航天方面的应用,其风险由客户单独承担,并且由客户独立负责满足与此类使用相关的所有法律和法规要求。

TI 已明确指定符合 ISO/TS16949 要求的产品,这些产品主要用于汽车。在任何情况下,因使用非指定产品而无法达到 ISO/TS16949 要求, TI 不承担任何责任。

	产品		应用
数字音频	www.ti.com.cn/audio	通信与电信	www.ti.com.cn/telecom
放大器和线性器件	www.ti.com.cn/amplifiers	计算机及周边	www.ti.com.cn/computer
数据转换器	www.ti.com.cn/dataconverters	消费电子	www.ti.com.cn/consumer-apps
DLP® 产品	www.dlp.com	能源	www.ti.com.cn/energy
DSP - 数字信号处理器	www.ti.com.cn/dsp	工业应用	www.ti.com.cn/industrial
时钟和计时器	www.ti.com.cn/clockandtimers	医疗电子	www.ti.com.cn/medical
接口	www.ti.com.cn/interface	安防应用	www.ti.com.cn/security
逻辑	www.ti.com.cn/logic	汽车电子	www.ti.com.cn/automotive
电源管理	www.ti.com.cn/power	视频和影像	www.ti.com.cn/video
微控制器 (MCU)	www.ti.com.cn/microcontrollers		
RFID 系统	www.ti.com.cn/rfidsys		
OMAP应用处理器	www.ti.com.cn/omap		
无线连通性	www.ti.com.cn/wirelessconnectivity	德州仪器在线技术支持社区	www.deyisupport.com

邮寄地址: 上海市浦东新区世纪大道1568号, 中建大厦32楼邮政编码: 200122
Copyright © 2014, 德州仪器半导体技术(上海)有限公司

PACKAGING INFORMATION

Orderable Device	Status (1)	Package Type	Package Drawing	Pins	Package Qty	Eco Plan (2)	Lead finish/ Ball material (6)	MSL Peak Temp (3)	Op Temp (°C)	Device Marking (4/5)	Samples
TPS630250RNCR	ACTIVE	VQFN-HR	RNC	14	3000	RoHS & Green	NIPDAU	Level-1-260C-UNLIM	-40 to 125	63025P	Samples
TPS630250RNCT	ACTIVE	VQFN-HR	RNC	14	250	RoHS & Green	NIPDAU	Level-1-260C-UNLIM	-40 to 125	63025P	Samples
TPS630250YFFR	ACTIVE	DSBGA	YFF	20	3000	RoHS & Green	SNAGCU	Level-1-260C-UNLIM	-40 to 125	TPS 630250	Samples
TPS630250YFFT	ACTIVE	DSBGA	YFF	20	250	RoHS & Green	SNAGCU	Level-1-260C-UNLIM	-40 to 125	TPS 630250	Samples
TPS630251YFFR	ACTIVE	DSBGA	YFF	20	3000	RoHS & Green	SNAGCU	Level-1-260C-UNLIM	-40 to 125	TPS 630251	Samples
TPS630251YFFT	ACTIVE	DSBGA	YFF	20	250	RoHS & Green	SNAGCU	Level-1-260C-UNLIM	-40 to 125	TPS 630251	Samples
TPS630252YFFR	ACTIVE	DSBGA	YFF	20	3000	RoHS & Green	SNAGCU	Level-1-260C-UNLIM	-40 to 125	TPS 630252	Samples
TPS630252YFFT	ACTIVE	DSBGA	YFF	20	250	RoHS & Green	SNAGCU	Level-1-260C-UNLIM	-40 to 125	TPS 630252	Samples

(1) The marketing status values are defined as follows:

ACTIVE: Product device recommended for new designs.

LIFEBUY: TI has announced that the device will be discontinued, and a lifetime-buy period is in effect.

NRND: Not recommended for new designs. Device is in production to support existing customers, but TI does not recommend using this part in a new design.

PREVIEW: Device has been announced but is not in production. Samples may or may not be available.

OBSOLETE: TI has discontinued the production of the device.

(2) **RoHS:** TI defines "RoHS" to mean semiconductor products that are compliant with the current EU RoHS requirements for all 10 RoHS substances, including the requirement that RoHS substance do not exceed 0.1% by weight in homogeneous materials. Where designed to be soldered at high temperatures, "RoHS" products are suitable for use in specified lead-free processes. TI may reference these types of products as "Pb-Free".

RoHS Exempt: TI defines "RoHS Exempt" to mean products that contain lead but are compliant with EU RoHS pursuant to a specific EU RoHS exemption.

Green: TI defines "Green" to mean the content of Chlorine (Cl) and Bromine (Br) based flame retardants meet JS709B low halogen requirements of <=1000ppm threshold. Antimony trioxide based flame retardants must also meet the <=1000ppm threshold requirement.

(3) MSL, Peak Temp. - The Moisture Sensitivity Level rating according to the JEDEC industry standard classifications, and peak solder temperature.

(4) There may be additional marking, which relates to the logo, the lot trace code information, or the environmental category on the device.

⁽⁵⁾ Multiple Device Markings will be inside parentheses. Only one Device Marking contained in parentheses and separated by a "-" will appear on a device. If a line is indented then it is a continuation of the previous line and the two combined represent the entire Device Marking for that device.

⁽⁶⁾ Lead finish/Ball material - Orderable Devices may have multiple material finish options. Finish options are separated by a vertical ruled line. Lead finish/Ball material values may wrap to two lines if the finish value exceeds the maximum column width.

Important Information and Disclaimer:The information provided on this page represents TI's knowledge and belief as of the date that it is provided. TI bases its knowledge and belief on information provided by third parties, and makes no representation or warranty as to the accuracy of such information. Efforts are underway to better integrate information from third parties. TI has taken and continues to take reasonable steps to provide representative and accurate information but may not have conducted destructive testing or chemical analysis on incoming materials and chemicals. TI and TI suppliers consider certain information to be proprietary, and thus CAS numbers and other limited information may not be available for release.

In no event shall TI's liability arising out of such information exceed the total purchase price of the TI part(s) at issue in this document sold by TI to Customer on an annual basis.

TAPE AND REEL INFORMATION



QUADRANT ASSIGNMENTS FOR PIN 1 ORIENTATION IN TAPE



*All dimensions are nominal

Device	Package Type	Package Drawing	Pins	SPQ	Reel Diameter (mm)	Reel Width W1 (mm)	A0 (mm)	B0 (mm)	K0 (mm)	P1 (mm)	W (mm)	Pin1 Quadrant
TPS630250RNCR	VQFN-HR	RNC	14	3000	330.0	12.4	2.8	3.3	1.2	8.0	12.0	Q1
TPS630250RNCT	VQFN-HR	RNC	14	250	180.0	12.4	2.8	3.3	1.2	8.0	12.0	Q1
TPS630250YFFR	DSBGA	YFF	20	3000	180.0	8.4	1.89	2.2	0.69	4.0	8.0	Q1
TPS630250YFFT	DSBGA	YFF	20	250	180.0	8.4	1.89	2.2	0.69	4.0	8.0	Q1
TPS630251YFFR	DSBGA	YFF	20	3000	180.0	8.4	1.89	2.2	0.69	4.0	8.0	Q1
TPS630251YFFT	DSBGA	YFF	20	250	180.0	8.4	1.89	2.2	0.69	4.0	8.0	Q1
TPS630252YFFR	DSBGA	YFF	20	3000	180.0	8.4	1.89	2.2	0.69	4.0	8.0	Q1
TPS630252YFFT	DSBGA	YFF	20	250	180.0	8.4	1.89	2.2	0.69	4.0	8.0	Q1

TAPE AND REEL BOX DIMENSIONS

*All dimensions are nominal

Device	Package Type	Package Drawing	Pins	SPQ	Length (mm)	Width (mm)	Height (mm)
TPS630250RNCR	VQFN-HR	RNC	14	3000	367.0	367.0	35.0
TPS630250RNCT	VQFN-HR	RNC	14	250	182.0	182.0	20.0
TPS630250YFFR	DSBGA	YFF	20	3000	182.0	182.0	20.0
TPS630250YFFT	DSBGA	YFF	20	250	182.0	182.0	20.0
TPS630251YFFR	DSBGA	YFF	20	3000	182.0	182.0	20.0
TPS630251YFFT	DSBGA	YFF	20	250	182.0	182.0	20.0
TPS630252YFFR	DSBGA	YFF	20	3000	182.0	182.0	20.0
TPS630252YFFT	DSBGA	YFF	20	250	182.0	182.0	20.0

RNC0014A



PACKAGE OUTLINE

VQFN-HR - 1 mm max height

PLASTIC QUAD FLATPACK - NO LEAD

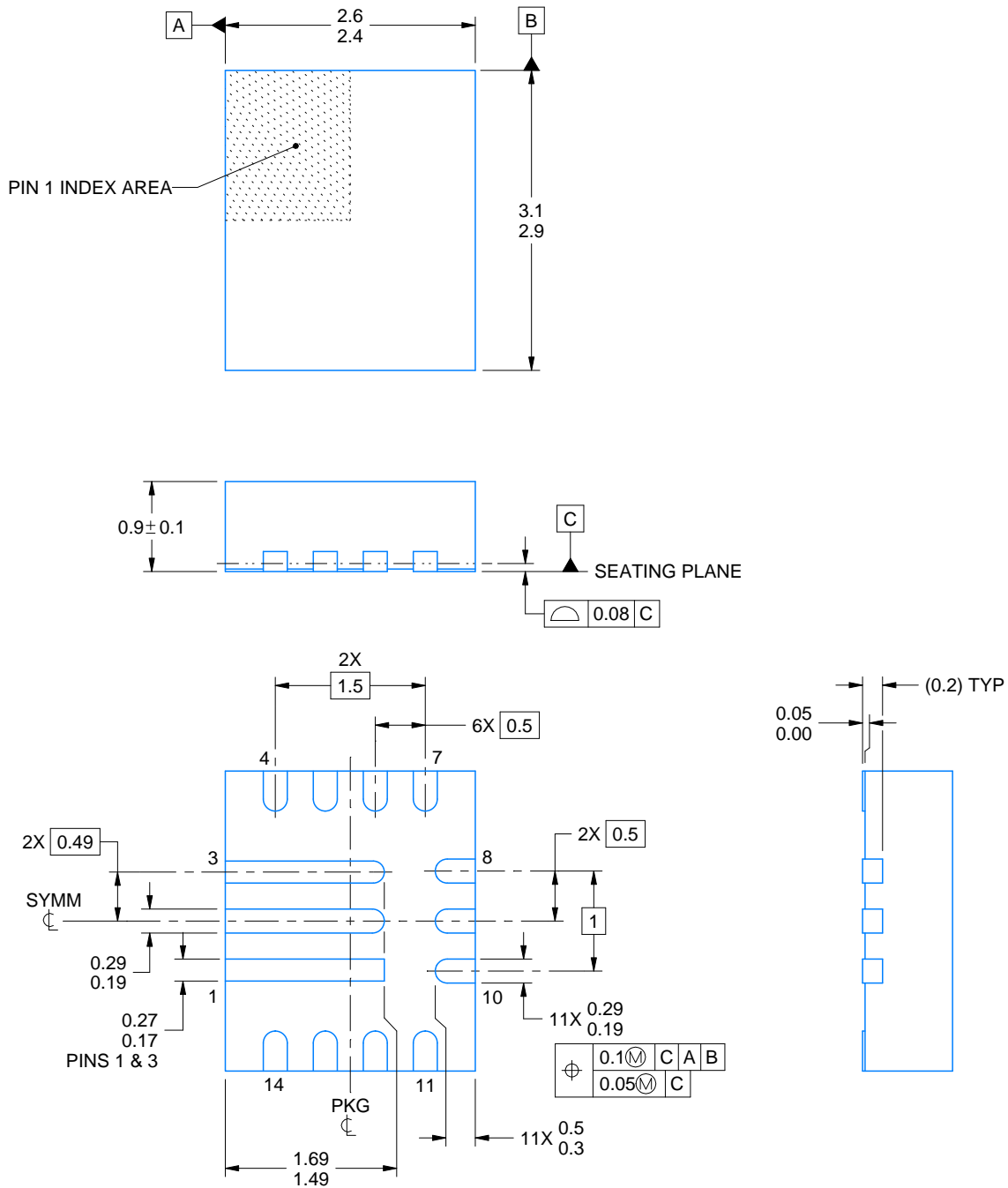

4221630/C 04/2018

NOTES:

1. All linear dimensions are in millimeters. Any dimensions in parenthesis are for reference only. Dimensioning and tolerancing per ASME Y14.5M.
2. This drawing is subject to change without notice.

EXAMPLE BOARD LAYOUT

RNC0014A

VQFN-HR - 1 mm max height

PLASTIC QUAD FLATPACK - NO LEAD

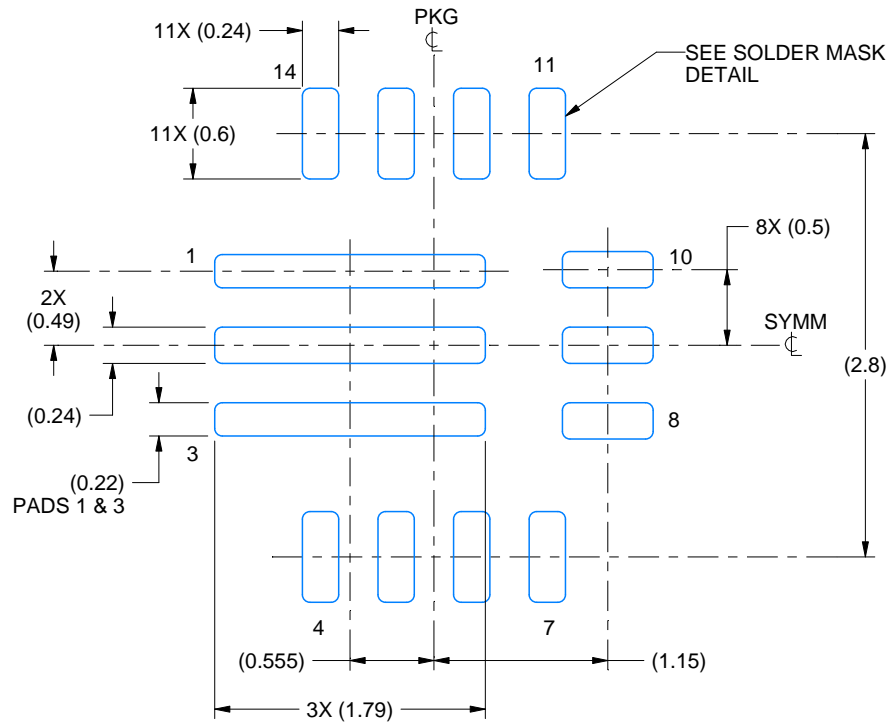

LAND PATTERN EXAMPLE
EXPOSED METAL SHOWN
SCALE:20X

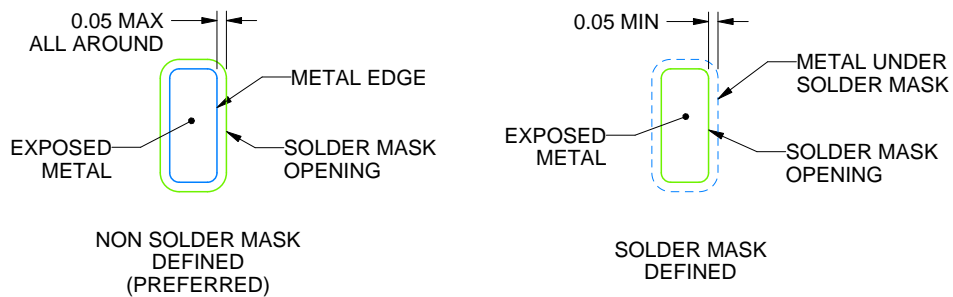

SOLDER MASK DETAILS

4221630/C 04/2018

NOTES: (continued)

3. For more information, see Texas Instruments literature number SLUA271 (www.ti.com/lit/slua271).
4. Solder mask tolerances between and around signal pads can vary based on board fabrication site.

EXAMPLE STENCIL DESIGN

RNC0014A

VQFN-HR - 1 mm max height

PLASTIC QUAD FLATPACK - NO LEAD

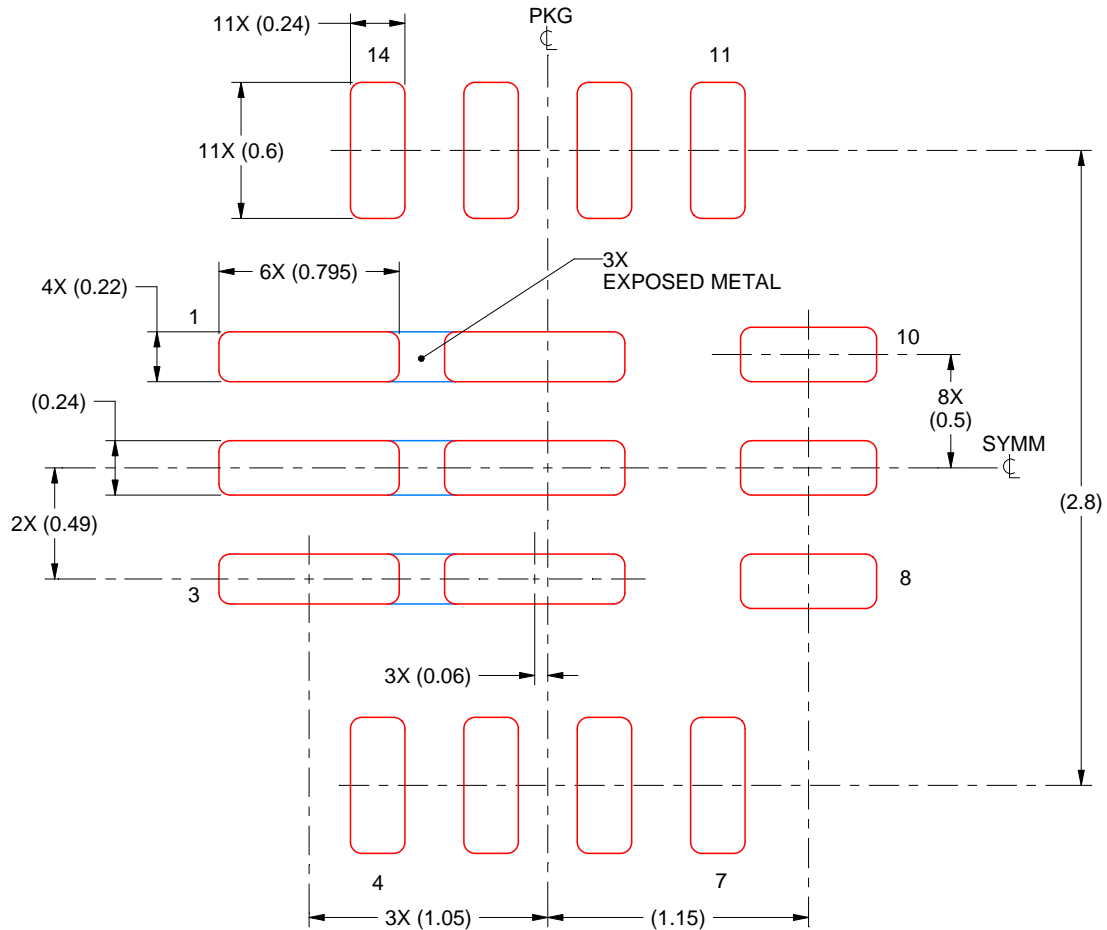

SOLDER PASTE EXAMPLE
BASED ON 0.125 mm THICK STENCIL
FOR EXPOSED PADS 1-3
89% PRINTED SOLDER COVERAGE BY AREA
SCALE:30X

4221630/C 04/2018

NOTES: (continued)

5. For alternate stencil design recommendations, see IPC-7525 or board assembly site preference.

MECHANICAL DATA

YFF (R-XBGA-N20)

DIE-SIZE BALL GRID ARRAY

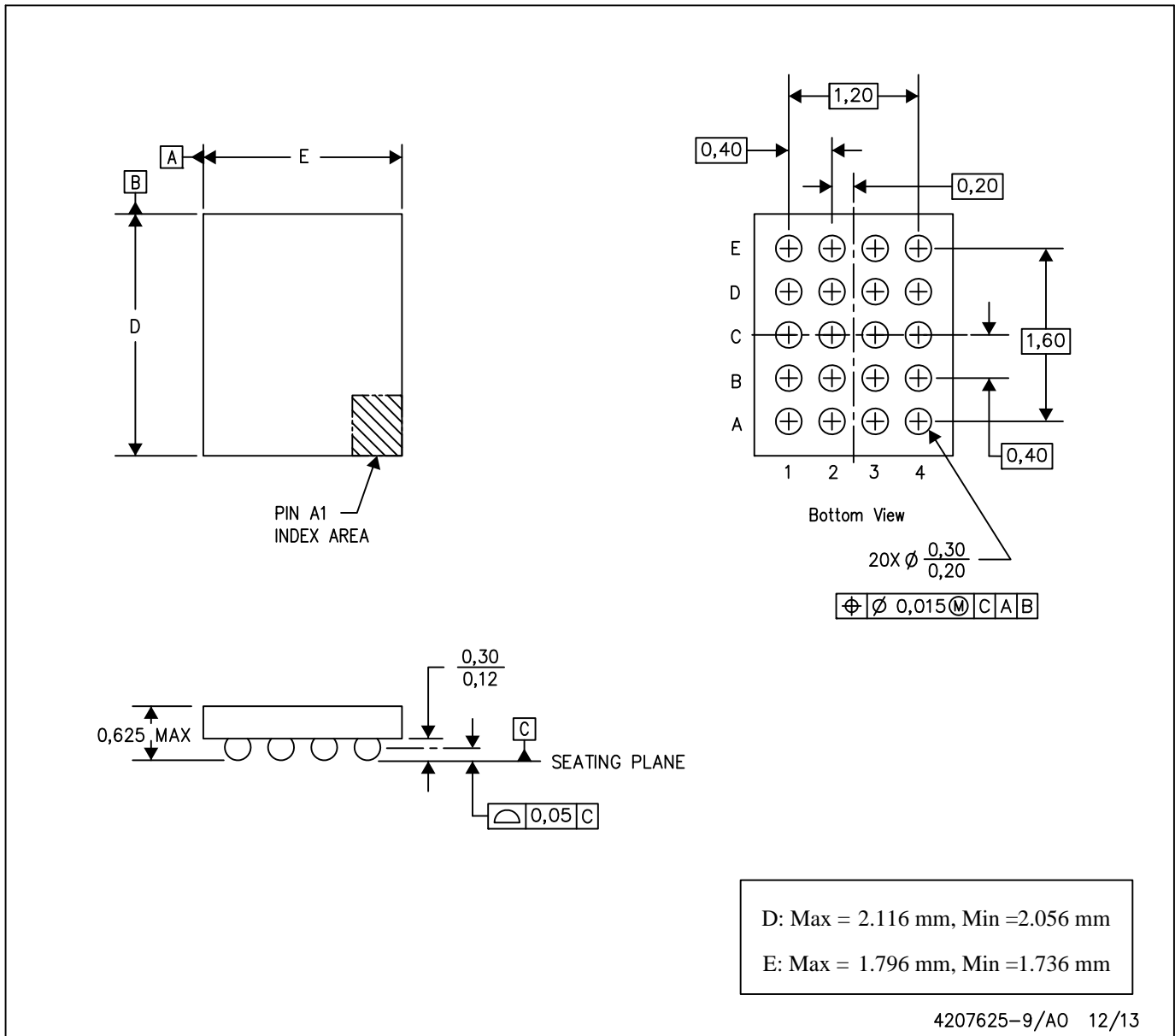

- NOTES: A. All linear dimensions are in millimeters. Dimensioning and tolerancing per ASME Y14.5M-1994.
 B. This drawing is subject to change without notice.
 C. NanoFree™ package configuration.

NanoFree is a trademark of Texas Instruments.

重要声明和免责声明

TI 均以“原样”提供技术性及其可靠性数据（包括数据表）、设计资源（包括参考设计）、应用或其他设计建议、网络工具、安全信息和其他资源，不保证其中不含任何瑕疵，且不做任何明示或暗示的担保，包括但不限于对适销性、适合某特定用途或不侵犯任何第三方知识产权的暗示担保。

所述资源可供专业开发人员应用TI 产品进行设计使用。您将对以下行为独自承担全部责任：(1) 针对您的应用选择合适的TI 产品；(2) 设计、验证并测试您的应用；(3) 确保您的应用满足相应标准以及任何其他安全、安保或其他要求。所述资源如有变更，恕不另行通知。TI 对您使用所述资源的授权仅限于开发资源所涉及TI 产品的相关应用。除此之外不得复制或展示所述资源，也不提供其它TI 或任何第三方的知识产权授权许可。如因使用所述资源而产生任何索赔、赔偿、成本、损失及债务等，TI 对此概不负责，并且您须赔偿由此对TI 及其代表造成的损害。

TI 所提供产品均受TI 的销售条款 (<http://www.ti.com.cn/zh-cn/legal/termsofsale.html>) 以及 [ti.com.cn](http://www.ti.com.cn) 上或随附TI 产品提供的其他可适用条款的约束。TI 提供所述资源并不扩展或以其他方式更改TI 针对TI 产品所发布的可适用的担保范围或担保免责声明。

邮寄地址：上海市浦东新区世纪大道 1568 号中建大厦 32 楼，邮政编码：200122

Copyright © 2020 德州仪器半导体技术（上海）有限公司