

TPS3809xxx-Q1 3-Pin Supply Voltage Supervisors

1 Features

- Qualified for Automotive Applications
- AEC-Q100 Qualified With the Following Results:
 - Device Temperature Grade 1: -40°C to $+125^{\circ}\text{C}$ Ambient Operating Temperature Range
 - Device HBM ESD Classification Level 2
 - Device CDM ESD Classification Level C5
- 3-Pin SOT-23 Package
- Supply Current of $9\ \mu\text{A}$ (Typical)
- Precision-Supply Voltage Monitor 2.5 V, 3 V, 3.3 V, 5 V
- Power-On Reset Generator With Fixed Delay Time of 200 ms
- Pin-For-Pin Compatible With MAX 809

2 Applications

- [Automotive Camera Systems](#)
- [Telematics](#)
- [Automotive Cluster](#)
- [Engine Controls](#)
- [Surround View Systems](#)

3 Description

The TPS3809 family of supervisory circuits provides circuit initialization and timing supervision, primarily for DSPs and processor-based systems. The newer [TLV809E](#) device is an alternative with the same pins, functions and electrical parameters.

During power-on, $\overline{\text{RESET}}$ is asserted when the supply voltage V_{DD} becomes higher than 1.1 V. Thereafter, the supervisory circuit monitors V_{DD} and keeps $\overline{\text{RESET}}$ active as long as V_{DD} remains below the threshold voltage V_{IT} . An internal timer delays the return of the output to the inactive state (high) to ensure proper system reset. The delay time, $t_{\text{d(typ)}} = 200\ \text{ms}$, starts after V_{DD} has risen above the threshold voltage V_{IT} . When the supply voltage drops below the threshold voltage V_{IT} , the output becomes active (low) again. No external components are required. All the devices of this family have a fixed sense-threshold voltage V_{IT} set by an internal voltage divider.

The product spectrum is designed for supply voltages of 2.5 V, 3 V, 3.3 V, and 5 V. The circuits are available in a 3-pin SOT-23. The TPS3809xxx-Q1 devices are characterized for operation over a temperature range of -40°C to 125°C , and are qualified in accordance with AEC-Q100 stress test qualification for integrated circuits.

Device Information (1)

PART NUMBER	PACKAGE	BODY SIZE (NOM)
TPS3809xxx-Q1	SOT-23 (3)	2.90 mm × 1.60 mm

(1) For all available packages, see the orderable addendum at the end of the datasheet.

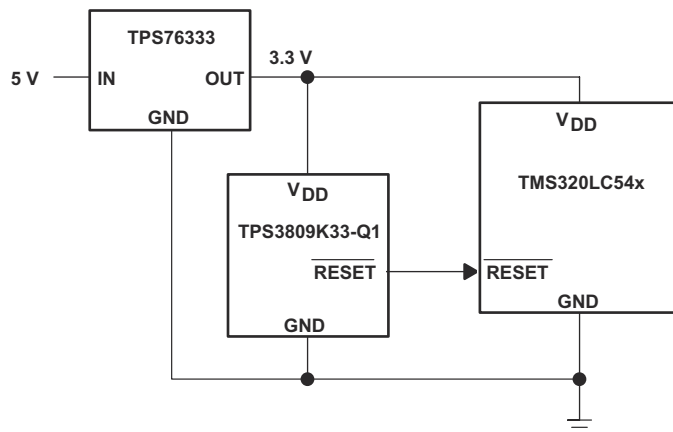

Typical Application



Table of Contents

1 Features	1	8.1 Overview.....	8
2 Applications	1	8.2 Functional Block Diagram.....	8
3 Description	1	8.3 Feature Description.....	8
4 Revision History	2	8.4 Device Functional Modes.....	8
5 Device Comparison	3	9 Application and Implementation	9
6 Pin Configuration and Functions	3	9.1 Application Information.....	9
6.1 Pin Functions.....	3	9.2 Typical Application.....	9
7 Specifications	4	10 Power Supply Recommendations	11
7.1 Absolute Maximum Ratings.....	4	11 Layout	12
7.2 ESD Ratings.....	4	11.1 Layout Guidelines.....	12
7.3 Recommended Operating Conditions.....	4	11.2 Layout Example.....	12
7.4 Thermal Information.....	4	12 Device and Documentation Support	13
7.5 Electrical Characteristics.....	5	12.1 Support Resources.....	13
7.6 Timing Requirements.....	5	12.2 Trademarks.....	13
7.7 Switching Characteristics.....	5	12.3 Electrostatic Discharge Caution.....	13
7.8 Timing Diagrams.....	6	12.4 Glossary.....	13
7.9 Typical Characteristics.....	7	13 Mechanical, Packaging, and Orderable Information	13
8 Detailed Description	8		

4 Revision History

NOTE: Page numbers for previous revisions may differ from page numbers in the current version.

Changes from Revision B (March 2016) to Revision C (December 2020)	Page
• Updated the numbering format for tables, figures, and cross-references throughout the document.....	1
• Added new sentence regarding the new TLV809E to the <i>Description</i> section.....	1
• Renamed <i>Device Comparison</i> modified device option table and added comparison table	3
• Changed VDD from 7 to 6.5 in <i>Absolute Maximum Ratings</i>	4
• Changed V _{OL} @ 500μA from 0.2 to 0.3 in <i>Electrical Characteristics</i>	5
• Changed t _w pulse duration from 3 to 10μs in <i>Timing Requirements</i>	5
• Changed t _{PHL} from 1 to 10μs in <i>Switching Characteristics</i>	5
• Deleted figure for Minimum Pulse Duration At V _{DD} in Typical Characteristics.....	7

Changes from Revision A (December 2002) to Revision B (February 2016)	Page
• Added AEC-Q100 Qualified information in bullets	1
• Changed <i>Applications</i> list items	1
• Added <i>ESD Ratings</i> table, <i>Feature Description</i> section, <i>Device Functional Modes</i> , <i>Application and Implementation</i> section, <i>Power Supply Recommendations</i> section, <i>Layout</i> section, <i>Device and Documentation Support</i> section, and <i>Mechanical, Packaging, and Orderable Information</i> section	1
• Changed device part numbers by adding -Q1 to them throughout document	5

5 Device Comparison

Table 5-1. Device Threshold Options

PRODUCT	THRESHOLD VOLTAGE
TPS3809J25QDBVRQ1	2.25 V
TPS3809L30QDBVRQ1	2.64 V
TPS3809K33QDBVRQ1	2.93 V
TPS3809I50QDBVRQ1	4.55 V

Table 5-2. Device Family Comparison

DEVICE	FUNCTION
TLV803	Open-Drain, $\overline{\text{RESET}}$ Output
TLV809	Push-Pull, $\overline{\text{RESET}}$ Output
TLV810	Push-Pull, RESET Output

6 Pin Configuration and Functions

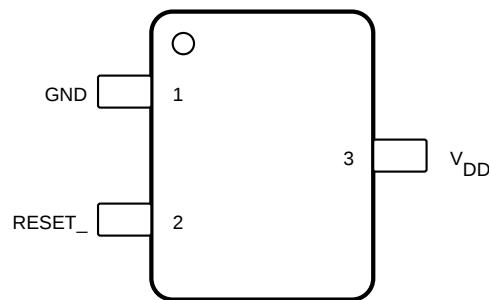

**Figure 6-1. DBV Package
3-Pin SOT-23
Top View**

6.1 Pin Functions

PIN		I/O	DESCRIPTION
NAME	NO.		
GND	1	—	Ground
$\overline{\text{RESET}}$	2	O	Reset output
V_{DD}	3	I	Supply voltage and supervising input

7 Specifications

7.1 Absolute Maximum Ratings

over operating free-air temperature range (unless otherwise noted)⁽¹⁾

	MIN	MAX	UNIT
Supply voltage, V_{DD} ⁽²⁾		6.5	V
All other pins ⁽²⁾	-0.3	6.5	V
Maximum low output current, I_{OL}		5	mA
Maximum high output current, I_{OH}		-5	mA
Input clamp current, I_{IK} ($V_I < 0$ or $V_I > V_{DD}$)	-20	20	mA
Output clamp current, I_{OK} ($V_O < 0$ or $V_O > V_{DD}$)	-20	20	mA
Continuous total power dissipation			
Operating free-air temperature range, T_A	-40	125	°C
Storage temperature, T_{stg}	-65	150	°C

- (1) Stresses beyond those listed under *Absolute Maximum Ratings* may cause permanent damage to the device. These are stress ratings only, which do not imply functional operation of the device at these or any other conditions beyond those indicated under *Recommended Operating Conditions*. Exposure to absolute-maximum-rated conditions for extended periods may affect device reliability.
- (2) All voltage values are with respect to GND. For reliable operation the device should not be operated at 6.5 V for more than $t = 1000$ h continuously.

7.2 ESD Ratings

		VALUE	UNIT
$V_{(ESD)}$ Electrostatic discharge	Human-body model (HBM), per AEC Q100-002 ⁽¹⁾	±2000	V
	Charged-device model (CDM), per AEC Q100-011	±750	

- (1) AEC Q100-002 indicates that HBM stressing shall be in accordance with the ANSI/ESDA/JEDEC JS-001 specification.

7.3 Recommended Operating Conditions

over operating free-air temperature range (unless otherwise noted)

		MIN	NOM	MAX	UNIT
V_{DD}	Supply voltage	2		6	V
T_A	Operating free-air temperature	-40		125	°C

7.4 Thermal Information

THERMAL METRIC ⁽¹⁾		TPS3809xxx-Q1	UNIT
		DBV (SOT-23)	
		3 PINS	
$R_{\theta JA}$	Junction-to-ambient thermal resistance	232.5	°C/W
$R_{\theta JC(top)}$	Junction-to-case (top) thermal resistance	187.6	°C/W
$R_{\theta JB}$	Junction-to-board thermal resistance	104.1	°C/W
Ψ_{JT}	Junction-to-top characterization parameter	40.5	°C/W
Ψ_{JB}	Junction-to-board characterization parameter	104.4	°C/W
$R_{\theta JC(bot)}$	Junction-to-case (bottom) thermal resistance	N/A	°C/W

- (1) For more information about traditional and new thermal metrics, see the *Semiconductor and IC Package Thermal Metrics* application report, [SPRA953](#).

7.5 Electrical Characteristics

over operating free-air temperature range (unless otherwise noted)

PARAMETER		TEST CONDITIONS	MIN	TYP	MAX	UNIT		
V _{OH}	High-level output voltage	V _{DD} = 2.5 V to 6 V, I _{OH} = -500 μA	V _{DD} - 0.2			V		
		V _{DD} = 3.3 V, I _{OH} = -2 μA	V _{DD} - 0.4					
		V _{DD} = 6 V, I _{OH} = -4 mA	T _A = -40°C to +25°C	V _{DD} - 0.4				
			T _A = 125°C	V _{DD} - 0.5				
V _{OL}	Low-level output voltage	V _{DD} = 2 V to 6 V, I _{OL} = 500 μA	0.3			V		
		V _{DD} = 3.3 V, I _{OL} = 2 mA	0.4					
		V _{DD} = 6 V, I _{OL} = 4 mA	0.4					
Power-up reset voltage ⁽¹⁾		V _{DD} ≥ 1.1 V, I _{OL} = 50 μA	0.2			V		
V _{IT-}	Negative-going input threshold voltage ⁽²⁾	TPS3809J25-Q1	T _A = -40°C to +125°C	2.20	2.25	2.30	V	
		TPS3809L30-Q1		2.58	2.64	2.7		
		TPS3809K33-Q1		2.87	2.93	2.99		
		TPS3809I50-Q1		T _A = -40°C to +85°C	4.45	4.55		4.65
				T _A = -40°C to +125°C	4.4	4.55		4.65
V _{hys}	Hysteresis	TPS3809J25-Q1	30			mV		
		TPS3809L30-Q1	35					
		TPS3809K33-Q1	40					
		TPS3809I50-Q1	60					
I _{DD}	Supply current	V _{DD} = 2 V, Output unconnected	9			μA		
		V _{DD} = 6 V, Output unconnected	20					
C _i	Input capacitance	V _i = 0 V to V _{DD}	5			pF		

(1) The lowest supply voltage at which RESET becomes active. t_r, V_{DD} ≥ 15 μs/V.

(2) To ensure best stability of the threshold voltage, a bypass capacitor (0.1 μF, ceramic) should be placed near the supply terminals.

7.6 Timing Requirements

R_L = 1 MΩ, C_L = 50 pF, T_A = 25°C

			MIN	NOM	MAX	UNIT
t _w	Pulse width at V _{DD}	V _{DD} = V _{IT-} + 0.2 V, V _{DD} = V _{IT-} - 0.2 V	10			μs

7.7 Switching Characteristics

R_L = 1 MΩ, C_L = 50 pF, T_A = 25°C

PARAMETER		TEST CONDITIONS	MIN	TYP	MAX	UNIT
t _d	Delay time	V _{DD} ≥ V _{IT-} + 0.2 V, See timing diagram, Section 7.8	120	200	280	ms
t _{PHL}	Propagation (delay) time, high-to-low-level output	V _{DD} to RESET delay V _{IL} = V _{IT-} - 0.2 V, V _{IH} = V _{IT-} + 0.2 V	10			μs

7.8 Timing Diagrams

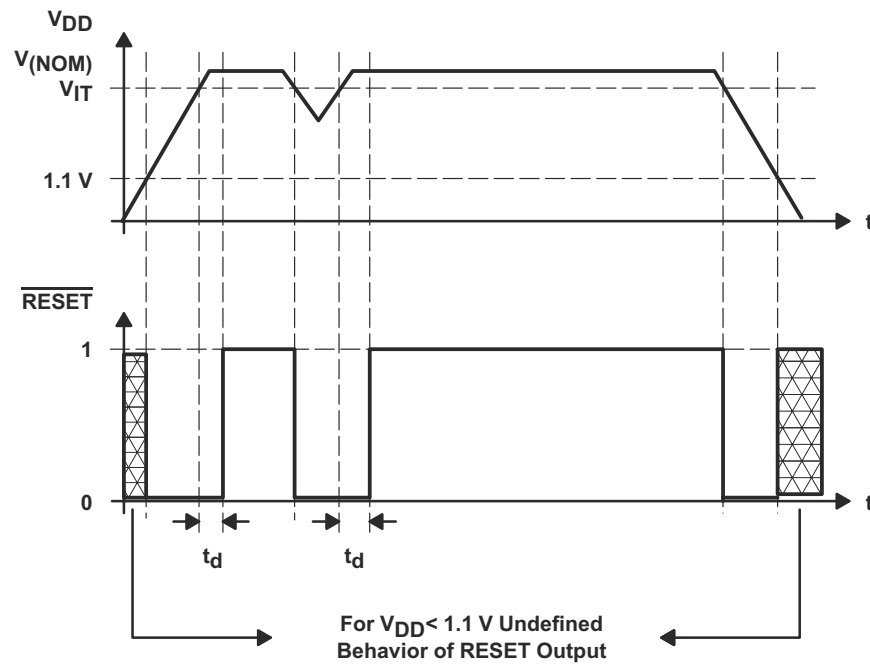

Figure 7-1. Timing Diagram

7.9 Typical Characteristics

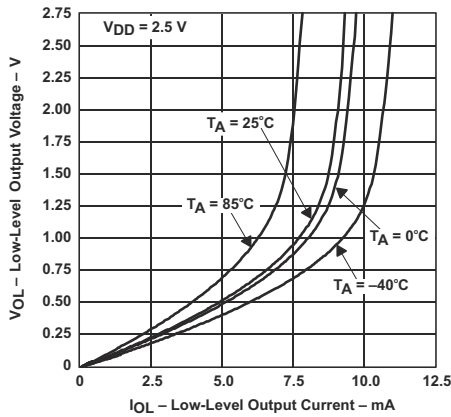

Figure 7-2. Low-Level Output Voltage vs Low-Level Output Current

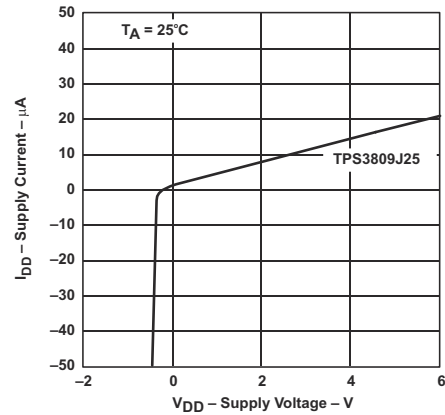
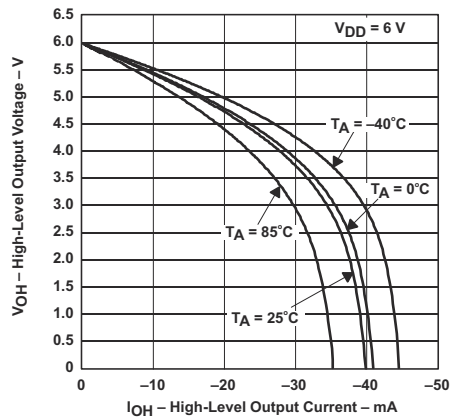
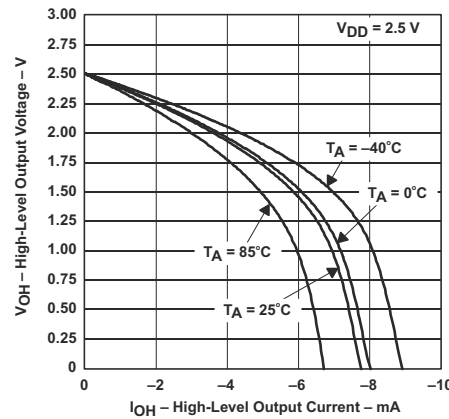

Figure 7-3. Supply Current vs Supply Voltage



$V_{DD} = 6\text{ V}$

Figure 7-4. High-Level Output Voltage vs High-Level Output Current



$V_{DD} = 2.5\text{ V}$

Figure 7-5. High-Level Output Voltage vs High-Level Output Current

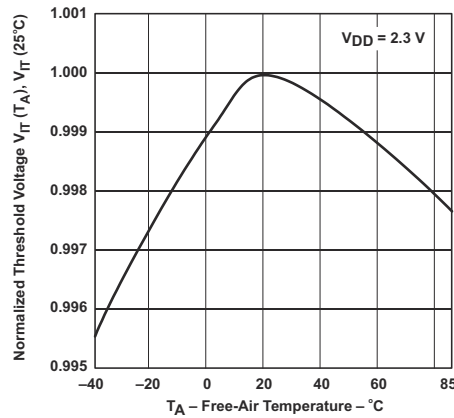

$V_{DD} = 2.3\text{ V}$

Figure 7-6. Normalized Input Threshold Voltage vs Free-Air Temperature at V_{DD}

8 Detailed Description

8.1 Overview

The TPS3809xxx-Q1 device is a low-current supervisory circuit for monitoring system voltages above 2 V. The device asserts an active-low $\overline{\text{RESET}}$ signal when VDD drops below a preset threshold. The $\overline{\text{RESET}}$ output remains low until VDD returns above its threshold. The device design is also to be relatively immune to short negative transients on the VDD pin.

8.2 Functional Block Diagram

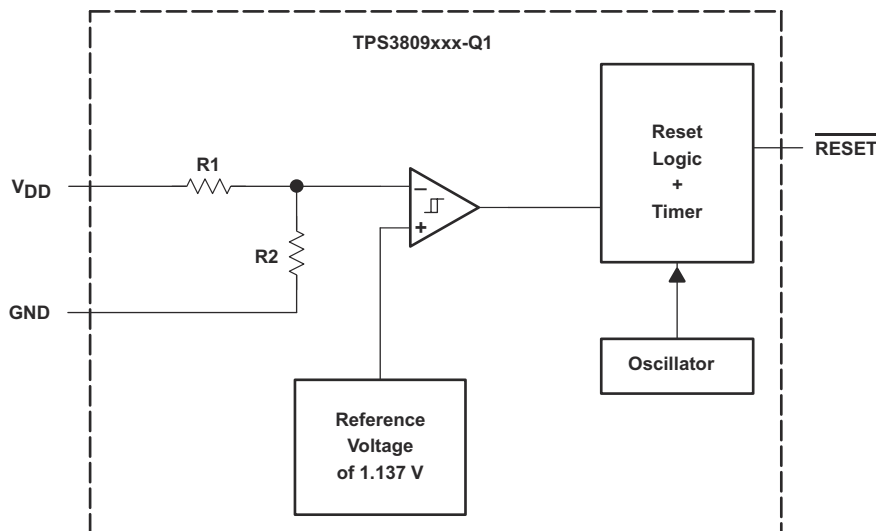

8.3 Feature Description

8.3.1 V_{DD} Monitoring

The V_{DD} pin provides a terminal at which a system voltage can be monitored. If the voltage on this pin drops below V_{IT}, $\overline{\text{RESET}}$ is asserted low. The comparator has a built-in hysteresis to ensure smooth $\overline{\text{RESET}}$ assertions and deassertions. Refer to [Section 5](#) to determine the V_{DD} voltage threshold for each device.

8.4 Device Functional Modes

TPS3809xxx-Q1 monitors one supply using the V_{DD} pin. When V_{DD} is above the V_{IT} threshold for the device, $\overline{\text{RESET}}$ will be high. When V_{DD} is below the V_{IT} threshold for the device, $\overline{\text{RESET}}$ will be low.

9 Application and Implementation

Note

Information in the following applications sections is not part of the TI component specification, and TI does not warrant its accuracy or completeness. TI's customers are responsible for determining suitability of components for their purposes, as well as validating and testing their design implementation to confirm system functionality.

9.1 Application Information

The TPS3809xxx-Q1 voltage supervisor device design asserts an active-low RESET signal when V_{DD} drops below a voltage threshold V_{IT} . The $\overline{\text{RESET}}$ signal remains low until the voltage returns above its threshold. The typical application is with a processor or microcontroller, which needs to be reset when the supply rail drops below a specified tolerance.

9.2 Typical Application

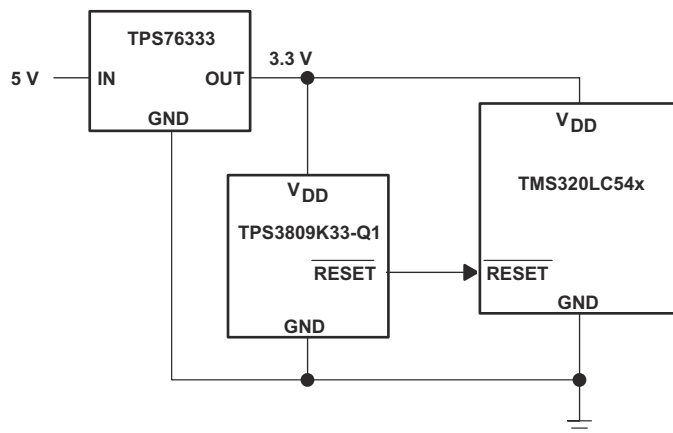

Figure 9-1. Typical Application Schematic

9.2.1 Design Requirements

Each device has a fixed-voltage monitoring threshold, and the device should be chosen based on the voltage being monitored. Refer to [Section 5](#) to determine the V_{DD} voltage threshold for each device. In this example, a 3.3V supply rail to a microcontroller will be monitored.

9.2.2 Detailed Design Procedure

Because a 3.3-V supply rail needs to be monitored, TPS3809K33-Q1 should be used. This device has a 2.93-V threshold for reset. Connect the 3.3-V supply to the V_{DD} pin and the reset output of the supervisor to the reset pin of the microcontroller.

9.2.3 Application Curves

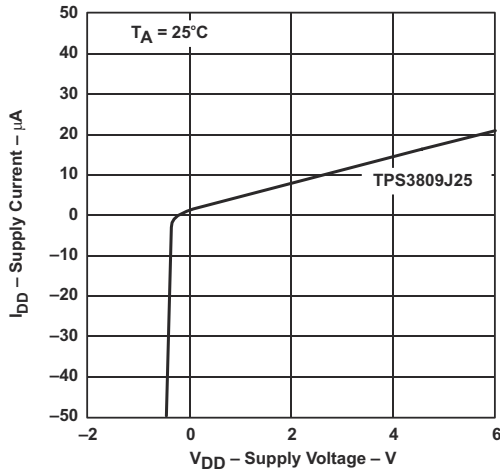

Figure 9-2. Supply Current vs Supply Voltage

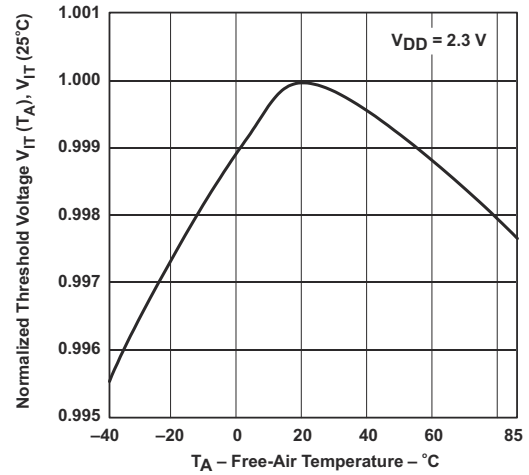

Figure 9-3. Normalized Input Threshold Voltage vs Free-Air Temperature at V_{DD}

10 Power Supply Recommendations

The TPS3809xxx-Q1 device design operates from an input supply from 2 V to 6 V. TI recommends placing a 0.1- μ F capacitor near the V_{DD} pin.

11 Layout

11.1 Layout Guidelines

TI recommends placing the 0.1- μF decoupling capacitor close to the V_{DD} pin. The V_{DD} and GND traces should be able to carry 30 μA without a significant drop in voltage.

11.2 Layout Example

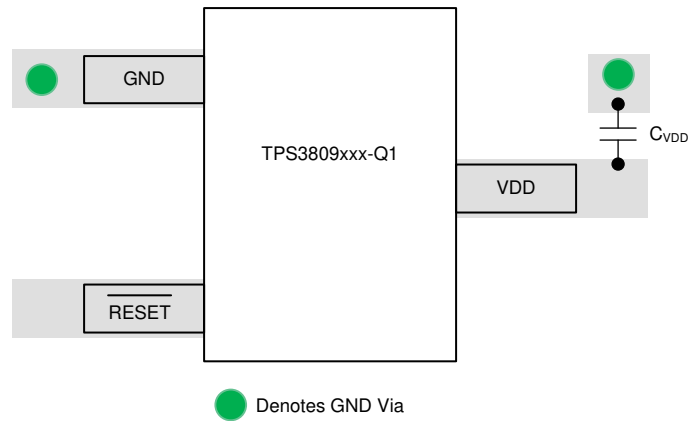

Figure 11-1. Layout Example

12 Device and Documentation Support

12.1 Support Resources

[TI E2E™ support forums](#) are an engineer's go-to source for fast, verified answers and design help — straight from the experts. Search existing answers or ask your own question to get the quick design help you need.

Linked content is provided "AS IS" by the respective contributors. They do not constitute TI specifications and do not necessarily reflect TI's views; see TI's [Terms of Use](#).

12.2 Trademarks

TI E2E™ is a trademark of Texas Instruments.

All trademarks are the property of their respective owners.

12.3 Electrostatic Discharge Caution



This integrated circuit can be damaged by ESD. Texas Instruments recommends that all integrated circuits be handled with appropriate precautions. Failure to observe proper handling and installation procedures can cause damage.

ESD damage can range from subtle performance degradation to complete device failure. Precision integrated circuits may be more susceptible to damage because very small parametric changes could cause the device not to meet its published specifications.

12.4 Glossary

[TI Glossary](#) This glossary lists and explains terms, acronyms, and definitions.

13 Mechanical, Packaging, and Orderable Information

The following pages include mechanical, packaging, and orderable information. This information is the most current data available for the designated devices. This data is subject to change without notice and revision of this document. For browser-based versions of this data sheet, refer to the left-hand navigation.

PACKAGING INFORMATION

Orderable Device	Status (1)	Package Type	Package Drawing	Pins	Package Qty	Eco Plan (2)	Lead finish/ Ball material (6)	MSL Peak Temp (3)	Op Temp (°C)	Device Marking (4/5)	Samples
2T09I50QDBVRG4Q	ACTIVE	SOT-23	DBV	3	3000	RoHS & Green	NIPDAU	Level-1-260C-UNLIM	-40 to 125	PDCQ	Samples
TPS3809I50QDBVRQ1	ACTIVE	SOT-23	DBV	3	3000	RoHS & Green	NIPDAU	Level-1-260C-UNLIM	-40 to 125	PDCQ	Samples
TPS3809K33QDBVRQ1	ACTIVE	SOT-23	DBV	3	3000	RoHS & Green	NIPDAU	Level-1-260C-UNLIM	-40 to 125	PDBQ	Samples
TPS3809L30QDBVRQ1	ACTIVE	SOT-23	DBV	3	3000	RoHS & Green	NIPDAU	Level-1-260C-UNLIM	-40 to 125	PDAQ	Samples

(1) The marketing status values are defined as follows:

ACTIVE: Product device recommended for new designs.

LIFEBUY: TI has announced that the device will be discontinued, and a lifetime-buy period is in effect.

NRND: Not recommended for new designs. Device is in production to support existing customers, but TI does not recommend using this part in a new design.

PREVIEW: Device has been announced but is not in production. Samples may or may not be available.

OBSOLETE: TI has discontinued the production of the device.

(2) **RoHS:** TI defines "RoHS" to mean semiconductor products that are compliant with the current EU RoHS requirements for all 10 RoHS substances, including the requirement that RoHS substance do not exceed 0.1% by weight in homogeneous materials. Where designed to be soldered at high temperatures, "RoHS" products are suitable for use in specified lead-free processes. TI may reference these types of products as "Pb-Free".

RoHS Exempt: TI defines "RoHS Exempt" to mean products that contain lead but are compliant with EU RoHS pursuant to a specific EU RoHS exemption.

Green: TI defines "Green" to mean the content of Chlorine (Cl) and Bromine (Br) based flame retardants meet JS709B low halogen requirements of <=1000ppm threshold. Antimony trioxide based flame retardants must also meet the <=1000ppm threshold requirement.

(3) MSL, Peak Temp. - The Moisture Sensitivity Level rating according to the JEDEC industry standard classifications, and peak solder temperature.

(4) There may be additional marking, which relates to the logo, the lot trace code information, or the environmental category on the device.

(5) Multiple Device Markings will be inside parentheses. Only one Device Marking contained in parentheses and separated by a "-" will appear on a device. If a line is indented then it is a continuation of the previous line and the two combined represent the entire Device Marking for that device.

(6) Lead finish/Ball material - Orderable Devices may have multiple material finish options. Finish options are separated by a vertical ruled line. Lead finish/Ball material values may wrap to two lines if the finish value exceeds the maximum column width.

Important Information and Disclaimer:The information provided on this page represents TI's knowledge and belief as of the date that it is provided. TI bases its knowledge and belief on information provided by third parties, and makes no representation or warranty as to the accuracy of such information. Efforts are underway to better integrate information from third parties. TI has taken and

continues to take reasonable steps to provide representative and accurate information but may not have conducted destructive testing or chemical analysis on incoming materials and chemicals. TI and TI suppliers consider certain information to be proprietary, and thus CAS numbers and other limited information may not be available for release.

In no event shall TI's liability arising out of such information exceed the total purchase price of the TI part(s) at issue in this document sold by TI to Customer on an annual basis.

OTHER QUALIFIED VERSIONS OF TPS3809-Q1 :

- Catalog: [TPS3809](#)
- Enhanced Product: [TPS3809-EP](#)

NOTE: Qualified Version Definitions:

- Catalog - TI's standard catalog product
- Enhanced Product - Supports Defense, Aerospace and Medical Applications

TAPE AND REEL INFORMATION

QUADRANT ASSIGNMENTS FOR PIN 1 ORIENTATION IN TAPE

*All dimensions are nominal

Device	Package Type	Package Drawing	Pins	SPQ	Reel Diameter (mm)	Reel Width W1 (mm)	A0 (mm)	B0 (mm)	K0 (mm)	P1 (mm)	W (mm)	Pin1 Quadrant
2T09I50QDBVRG4Q	SOT-23	DBV	3	3000	180.0	9.0	3.3	3.2	1.47	4.0	8.0	Q3
TPS3809I50QDBVRQ1	SOT-23	DBV	3	3000	180.0	9.0	3.3	3.2	1.47	4.0	8.0	Q3
TPS3809K33QDBVRQ1	SOT-23	DBV	3	3000	180.0	9.0	3.3	3.2	1.47	4.0	8.0	Q3
TPS3809L30QDBVRQ1	SOT-23	DBV	3	3000	180.0	9.0	3.3	3.2	1.47	4.0	8.0	Q3

TAPE AND REEL BOX DIMENSIONS

*All dimensions are nominal

Device	Package Type	Package Drawing	Pins	SPQ	Length (mm)	Width (mm)	Height (mm)
2T09I50QDBVRGB4Q	SOT-23	DBV	3	3000	182.0	182.0	20.0
TPS3809I50QDBVRQ1	SOT-23	DBV	3	3000	182.0	182.0	20.0
TPS3809K33QDBVRQ1	SOT-23	DBV	3	3000	182.0	182.0	20.0
TPS3809L30QDBVRQ1	SOT-23	DBV	3	3000	182.0	182.0	20.0

DBV0003A

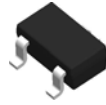

PACKAGE OUTLINE

SOT-23 - 1.45 mm max height

SMALL OUTLINE TRANSISTOR

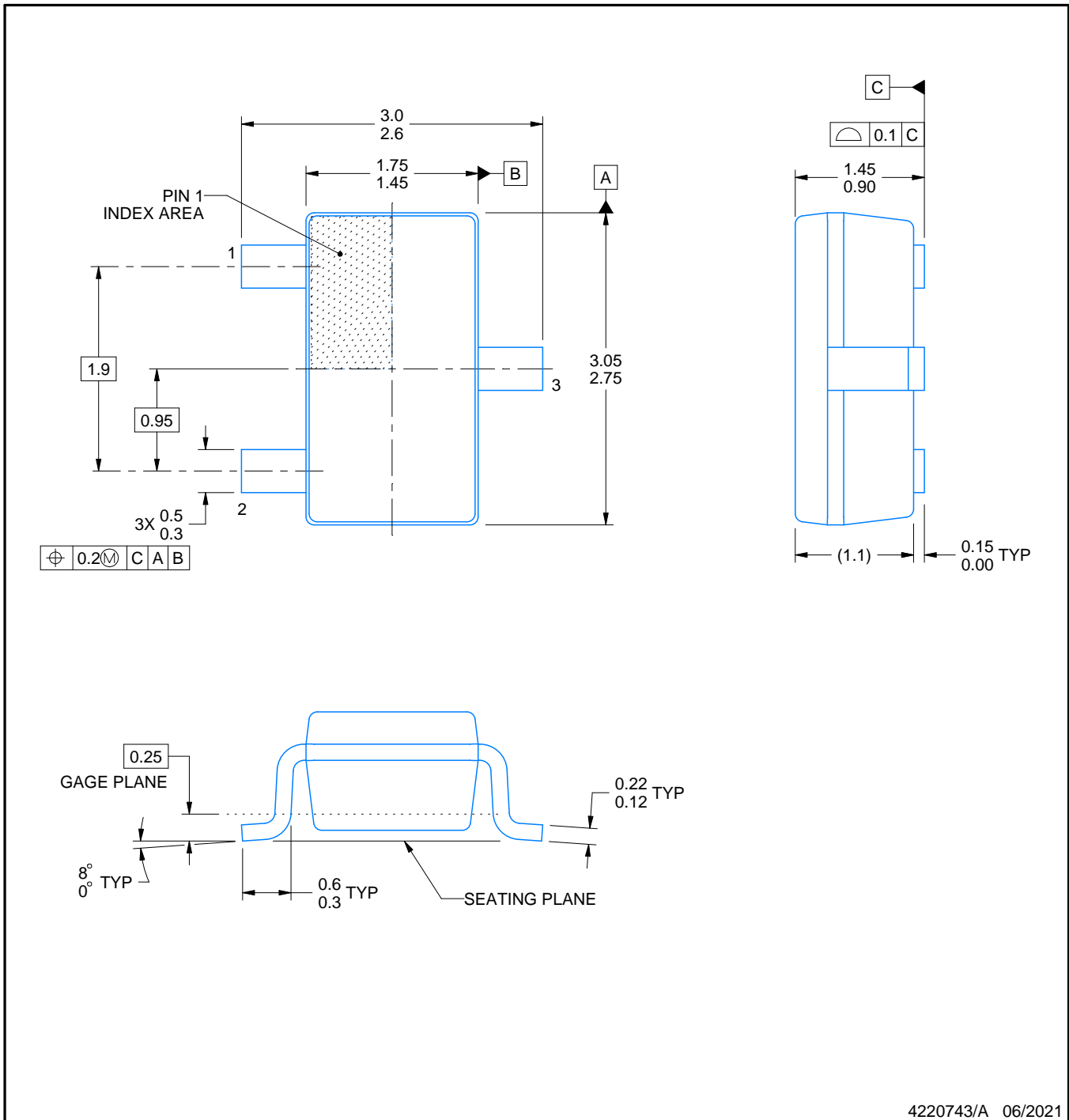

4220743/A 06/2021

NOTES:

1. All linear dimensions are in millimeters. Any dimensions in parenthesis are for reference only. Dimensioning and tolerancing per ASME Y14.5M.
2. This drawing is subject to change without notice.
3. Reference JEDEC MO-178.
4. Body dimensions do not include mold flash, protrusions, or gate burrs. Mold flash, protrusions, or gate burrs shall not exceed 0.25 mm per side.

EXAMPLE BOARD LAYOUT

DBV0003A

SOT-23 - 1.45 mm max height

SMALL OUTLINE TRANSISTOR

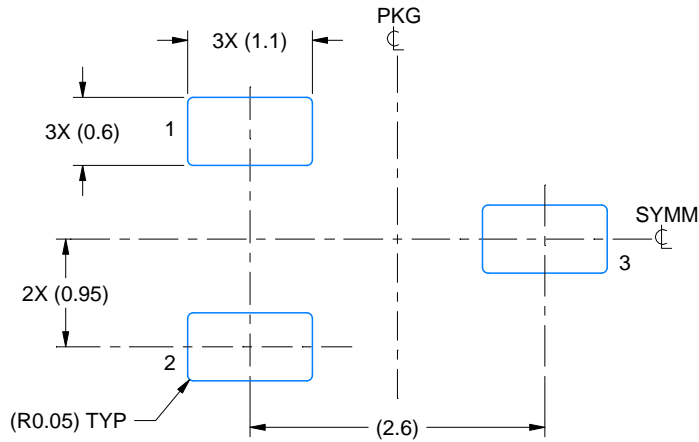

LAND PATTERN EXAMPLE
EXPOSED METAL SHOWN
SCALE:15X

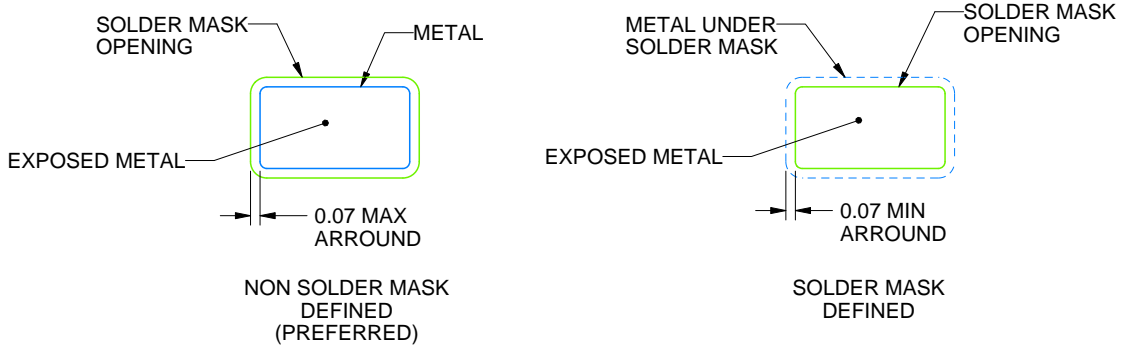

SOLDER MASK DETAILS

4220743/A 06/2021

NOTES: (continued)

- 5. Publication IPC-7351 may have alternate designs.
- 6. Solder mask tolerances between and around signal pads can vary based on board fabrication site.

EXAMPLE STENCIL DESIGN

DBV0003A

SOT-23 - 1.45 mm max height

SMALL OUTLINE TRANSISTOR

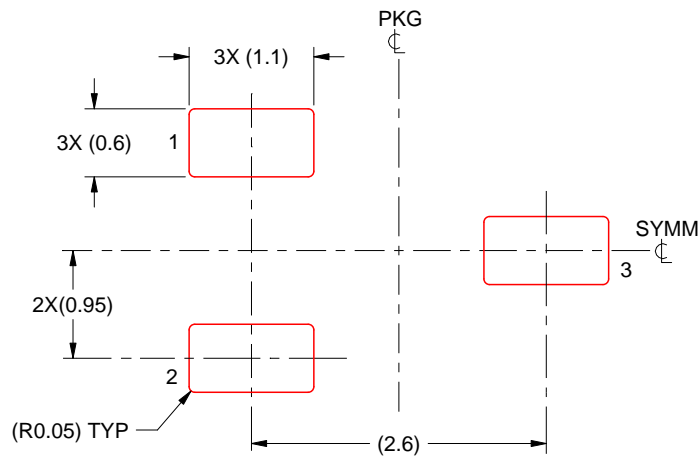

SOLDER PASTE EXAMPLE
BASED ON 0.125 mm THICK STENCIL
SCALE:15X

4220743/A 06/2021

NOTES: (continued)

7. Laser cutting apertures with trapezoidal walls and rounded corners may offer better paste release. IPC-7525 may have alternate design recommendations.
8. Board assembly site may have different recommendations for stencil design.

IMPORTANT NOTICE AND DISCLAIMER

TI PROVIDES TECHNICAL AND RELIABILITY DATA (INCLUDING DATASHEETS), DESIGN RESOURCES (INCLUDING REFERENCE DESIGNS), APPLICATION OR OTHER DESIGN ADVICE, WEB TOOLS, SAFETY INFORMATION, AND OTHER RESOURCES "AS IS" AND WITH ALL FAULTS, AND DISCLAIMS ALL WARRANTIES, EXPRESS AND IMPLIED, INCLUDING WITHOUT LIMITATION ANY IMPLIED WARRANTIES OF MERCHANTABILITY, FITNESS FOR A PARTICULAR PURPOSE OR NON-INFRINGEMENT OF THIRD PARTY INTELLECTUAL PROPERTY RIGHTS.

These resources are intended for skilled developers designing with TI products. You are solely responsible for (1) selecting the appropriate TI products for your application, (2) designing, validating and testing your application, and (3) ensuring your application meets applicable standards, and any other safety, security, or other requirements. These resources are subject to change without notice. TI grants you permission to use these resources only for development of an application that uses the TI products described in the resource. Other reproduction and display of these resources is prohibited. No license is granted to any other TI intellectual property right or to any third party intellectual property right. TI disclaims responsibility for, and you will fully indemnify TI and its representatives against, any claims, damages, costs, losses, and liabilities arising out of your use of these resources.

TI's products are provided subject to TI's Terms of Sale (<https://www.ti.com/legal/termsofsale.html>) or other applicable terms available either on [ti.com](https://www.ti.com) or provided in conjunction with such TI products. TI's provision of these resources does not expand or otherwise alter TI's applicable warranties or warranty disclaimers for TI products.

Mailing Address: Texas Instruments, Post Office Box 655303, Dallas, Texas 75265
Copyright © 2021, Texas Instruments Incorporated