

# 具有反极性保护和过压保护的 LM74502 低 IQ 高侧开关控制器

## 1 特性

- 3.2V 至 65V 输入范围 ( 3.9V 启动 )
- -65V 输入反向电压额定值
- 集成电荷泵用于驱动
  - 外部背对背 N 沟道 MOSFET
  - 外部高侧开关 MOSFET
  - 外部反极性保护 MOSFET
- 栅极驱动器型号
  - LM74502 : 60  $\mu$ A 峰值栅极驱动拉电流能力
  - LM74502H : 11mA 峰值栅极驱动拉电流能力
- 2.3A 峰值栅极灌电流能力
- 使能引脚特性
- 45 $\mu$ A 典型工作静态电流 ( EN/UVLO = 高电平 )
- 1 $\mu$ A 关断电流 ( EN/UVLO = 低电平 )
- 可调节过压和欠压保护
- - 40°C 至 +125°C 环境工作温度范围
- 采用 8 引脚 SOT-23 封装 2.90mm  $\times$  1.60mm

## 2 应用

- 工厂自动化和控制 - PLC 数字输出模块
- 工业电机驱动
- 工业运输
- 电源反极性保护

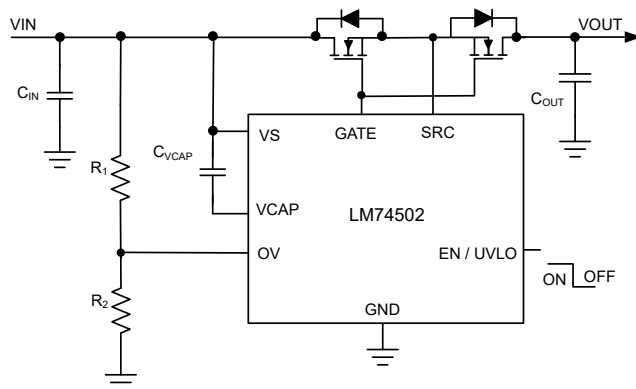

LM74502 典型应用原理图

## 3 说明

LM74502/LM74502H 控制器与外部背对背连接的 N 沟道 MOSFET 配合工作，可实现低损耗反极性保护和负载断开的解决方案。该器件也可以配置为具有过压保护功能的负载开关，用于驱动高侧 MOSFET。3.2V 至 65V 的宽电源输入范围可实现对众多常用直流总线电压（例如，12V、24V 和 48V 输入系统）的控制。该器件可以承受并保护负载免受低至 -65V 的负电源电压的影响。LM74502/LM74502H 没有反向电流阻断功能，仅适用于进行输入反极性保护。

LM74502 控制器可提供适用于外部 N 沟道 MOSFET 的电荷泵栅极驱动。当使能引脚处于低电平时，控制器关闭，消耗大约 1 $\mu$ A 的电流，从而在进入睡眠模式时提供低系统电流。LM74502 和 LM74502H 还具有可编程的过压和欠压保护功能，可在发生故障时将负载从输入源切断。这些器件采用 2.9mm  $\times$  1.6mm 8 引脚 DDF 封装，额定工作温度范围为 - 40°C 至 +125°C。

### 器件信息(1)

器件型号	封装	封装尺寸 ( 标称值 )
LM74502	SOT-23 (8)	2.90mm $\times$ 1.60mm
LM74502H(2)		

- (1) 如需了解所有可用封装，请参阅数据表末尾的可订购产品附录。
- (2) 产品预发布。

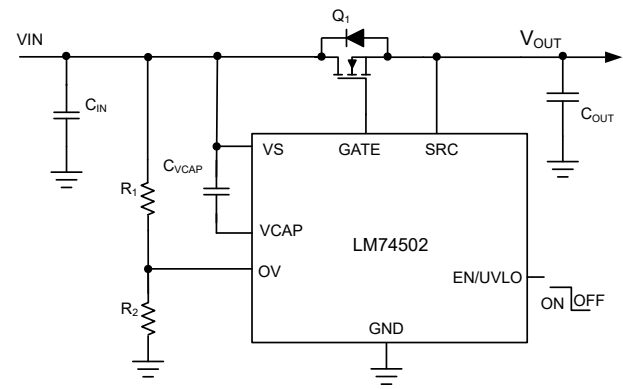

具有过压保护功能的 LM74502 负载开关控制器



## Table of Contents

<b>1 特性</b> .....	<b>1</b>	<b>9 Application and Implementation</b> .....	<b>14</b>
<b>2 应用</b> .....	<b>1</b>	9.1 Application Information.....	14
<b>3 说明</b> .....	<b>1</b>	9.2 Typical Application.....	14
<b>4 Revision History</b> .....	<b>2</b>	9.3 Input Surge Stopper Using LM74502, LM74502H....	17
<b>5 Pin Configuration and Functions</b> .....	<b>3</b>	9.4 Fast Turn-On and Turn-Off High Side Switch Driver Using LM74502H.....	18
<b>6 Specifications</b> .....	<b>4</b>	<b>10 Power Supply Recommendations</b> .....	<b>19</b>
6.1 Absolute Maximum Ratings.....	4	<b>11 Layout</b> .....	20
6.2 ESD Ratings.....	4	11.1 Layout Guidelines.....	20
6.3 Recommended Operating Conditions.....	4	11.2 Layout Example.....	20
6.4 Thermal Information.....	5	<b>12 Device and Documentation Support</b> .....	<b>21</b>
6.5 Electrical Characteristics.....	5	12.1 接收文档更新通知.....	21
6.6 Switching Characteristics.....	6	12.2 支持资源.....	21
6.7 Typical Characteristics.....	7	12.3 Trademarks.....	21
<b>7 Parameter Measurement Information</b> .....	<b>9</b>	12.4 Electrostatic Discharge Caution.....	21
<b>8 Detailed Description</b> .....	<b>10</b>	12.5 术语表.....	21
8.1 Overview.....	10	<b>13 Mechanical, Packaging, and Orderable   Information</b> .....	<b>22</b>
8.2 Functional Block Diagram.....	10		
8.3 Feature Description.....	10		
8.4 Device Functional Modes.....	13		

## 4 Revision History

注：以前版本的页码可能与当前版本的页码不同

DATE	REVISION	NOTES
December 2021	*	Initial release.

## 5 Pin Configuration and Functions



图 5-1. DDF Package 8-Pin SOT-23 LM74502 Top View

表 5-1. LM74502 Pin Functions

PIN		I/O <sup>(1)</sup>	DESCRIPTION
NO.	NAME		
1	EN/UVLO	I	EN/UVLO Input. Connect to VS pin for always ON operation. Can be driven externally from a micro controller I/O. Pulling the pin low below $V_{(ENF)}$ makes the device enter into low $I_q$ shutdown mode. For UVLO, connect an external resistor ladder from input supply to EN/UVLO to ground.
2	GND	G	Ground pin
3	N.C	—	No connection
4	VCAP	O	Charge pump output. Connect to external charge pump capacitor.
5	VS	I	Input power supply pin to the controller. Connect a 100-nF capacitor across VS and GND pins.
6	GATE	O	Gate drive output. Connect to gate of the external N-channel MOSFET.
7	OV	I	Adjustable overvoltage threshold input. Connect a resistor ladder from input supply to OV pin to ground. When the voltage at OV pin exceeds the overvoltage cut-off threshold then the GATE is pulled low. GATE turns ON when the OV pin voltage goes below the OVP falling threshold. Connect OV pin to ground when OV feature is not used.
8	SRC	I	Source pin. Connect to common source point of external back-to-back connected N-channel MOSFETs or the source pin of the high side switch MOSFET.

(1) I = Input, O = Output, G = GND

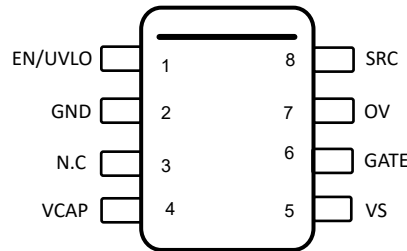
## 6 Specifications

### 6.1 Absolute Maximum Ratings

over operating free-air temperature range (unless otherwise noted)<sup>(1)</sup>

		MIN	MAX	UNIT
Input Pins	VS to GND	- 65	65	V
	EN/UVLO, OV to GND, $V_{(s)} > 0$ V	- 0.3	65	V
	EN/UVLO, OV, $V_{(s)} \leq 0$ V	$V_{(s)}$	$(65 + V_{(s)})$	
	SRC to GND, $V_{(s)} \leq 0$ V		$(V_{(s)} + 0.3)$	V
	SRC to GND, $V_{(s)} > 0$ V	$-(70 - V_{(s)})$	$V_{(s)}$	V
Output Pins	GATE to SRC	0	15	V
	VCAP to VS	- 0.3	15	V
Operating junction temperature <sup>(2)</sup>		- 40	150	°C
Storage temperature, $T_{stg}$		- 40	150	°C

- (1) Operation outside the Absolute Maximum Ratings may cause permanent device damage. Absolute Maximum Ratings do not imply functional operation of the device at these or any other conditions beyond those listed under Recommended Operating Conditions. If used outside the Recommended Operating Conditions but within the Absolute Maximum Ratings, the device may not be fully functional, and this may affect device reliability, functionality, performance, and shorten the device lifetime.
- (2) High junction temperatures degrade operating lifetimes. Operating lifetime is de-rated for junction temperatures greater than 125°C.

### 6.2 ESD Ratings

			VALUE	UNIT
$V_{(ESD)}$	Electrostatic discharge	Human body model (HBM), per ANSI/ESDA/JEDEC JS-001, all pins <sup>(1)</sup>	±2000	V
		Charged device model (CDM), per ANSI/ESDA/JEDEC JS-002, all pins <sup>(2)</sup>	±750	

- (1) JEDEC document JEP155 states that 500-V HBM allows safe manufacturing with a standard ESD control process.
- (2) JEDEC document JEP157 states that 250-V CDM allows safe manufacturing with a standard ESD control process.

### 6.3 Recommended Operating Conditions

over operating free-air temperature range (unless otherwise noted)<sup>(1)</sup>

		MIN	NOM	MAX	UNIT
Input Pins	VS to GND	- 60		60	V
	EN/UVLO, OV, SRC to GND	- 60		60	
External capacitance	VS	22			nF
	VCAP to VS	0.1			μF
External MOSFET max $V_{GS}$ rating	GATE to SRC	15			V
$T_J$	Operating junction temperature range <sup>(2)</sup>	- 40		150	°C

- (1) Recommended Operating Conditions are conditions under which the device is intended to be functional. For specifications and test conditions, see *electrical characteristics*.
- (2) High junction temperatures degrade operating lifetimes. Operating lifetime is de-rated for junction temperatures greater than 125°C.

## 6.4 Thermal Information

THERMAL METRIC <sup>(1)</sup>		LM74502 LM74502H <sup>(2)</sup>	UNIT
		DDF (SOT)	
		8 PINS	
$R_{\theta JA}$	Junction-to-ambient thermal resistance	133.8	°C/W
$R_{\theta JC(top)}$	Junction-to-case (top) thermal resistance	72.6	°C/W
$R_{\theta JB}$	Junction-to-board thermal resistance	54.5	°C/W
$\Psi_{JT}$	Junction-to-top characterization parameter	4.6	°C/W
$\Psi_{JB}$	Junction-to-board characterization parameter	54.2	°C/W

- (1) For more information about traditional and new thermal metrics, see the Semiconductor and IC Package Thermal Metrics application report, SPRA953.
- (2) Product preview

## 6.5 Electrical Characteristics

$T_J = -40^{\circ}\text{C}$  to  $+125^{\circ}\text{C}$ ; typical values at  $T_J = 25^{\circ}\text{C}$ ,  $V_{(VS)} = 12\text{ V}$ ,  $C_{(VCAP)} = 0.1\ \mu\text{F}$ ,  $V_{(EN/UVLO)} = 3.3\text{ V}$ , over operating free-air temperature range (unless otherwise noted)

PARAMETER		TEST CONDITIONS	MIN	TYP	MAX	UNIT
<b>V<sub>S</sub> SUPPLY VOLTAGE</b>						
$V_{(VS)}$	Operating input voltage		4		60	V
$V_{(VS\_POR)}$	VS POR Rising threshold				3.9	V
	VS POR Falling threshold		2.2	2.8	3.1	V
$V_{(VS\_POR(Hys))}$	VS POR Hysteresis		0.44		0.67	V
$I_{(SHDN)}$	Shutdown Supply Current	$V_{(EN/UVLO)} = 0\text{ V}$		0.9	1.5	$\mu\text{A}$
$I_{(Q)}$	Operating Quiescent Current	$I_{GND}$		45	65	$\mu\text{A}$
$I_{(REV)}$	VS pin leakage current during input reverse polarity	$0\text{ V} \leq V_{(VS)} \leq -65\text{ V}$		100	150	$\mu\text{A}$
<b>ENABLE INPUT</b>						
$V_{(EN\_UVLOF)}$	Enable/UVLO falling threshold		1.027	1.14	1.235	V
$V_{(EN\_UVLOR)}$	Enable/UVLO rising threshold		1.16	1.24	1.32	
$V_{(ENF)}$	Enable threshold voltage for low $I_Q$ shutdown		0.32	0.64	0.94	V
$V_{(EN\_Hys)}$	Enable Hysteresis		38	90	132	mV
$I_{(EN/UVLO)}$	Enable sink current	$V_{(EN/UVLO)} = 12\text{ V}$		3	5	$\mu\text{A}$
<b>GATE DRIVE</b>						
$I_{(GATE)}$	Peak source current	$V_{(GATE)} - V_{(SRC)} = 5\text{ V}$	40	60	77	$\mu\text{A}$
$I_{(GATE)}$	Peak source current	$V_{(GATE)} - V_{(SRC)} = 5\text{ V}$ , LM74502H <sup>(1)</sup>	3	11		mA
	Peak sink current	EN= High to Low $V_{(GATE)} - V_{(SRC)} = 5\text{ V}$		2370		mA
$R_{DS(ON)}$	discharge switch $R_{DS(ON)}$	EN = High to Low $V_{(GATE)} - V_{(SRC)} = 100\text{ mV}$	0.4		2	$\Omega$
<b>CHARGE PUMP</b>						
$I_{(VCAP)}$	Charge Pump source current (Charge pump on)	$V_{(VCAP)} - V_{(VS)} = 7\text{ V}$	162	300	600	$\mu\text{A}$
	Charge Pump sink current (Charge pump off)	$V_{(VCAP)} - V_{(VS)} = 14\text{ V}$		5	10	$\mu\text{A}$
$V_{(VCAP)} - V_{(VS)}$	Charge pump voltage at $V_{(VS)} = 3.2\text{ V}$	$I_{(VCAP)} \leq 30\ \mu\text{A}$	8			V
$V_{(VCAP)} - V_{(VS)}$	Charge pump turn on voltage		10.3	11.6	13	V
$V_{(VCAP)} - V_{(VS)}$	Charge pump turn off voltage		11	12.4	13.9	V

## 6.5 Electrical Characteristics (continued)

$T_J = -40^\circ\text{C}$  to  $+125^\circ\text{C}$ ; typical values at  $T_J = 25^\circ\text{C}$ ,  $V_{(VS)} = 12\text{ V}$ ,  $C_{(VCAP)} = 0.1\ \mu\text{F}$ ,  $V_{(EN/UVLO)} = 3.3\text{ V}$ , over operating free-air temperature range (unless otherwise noted)

PARAMETER		TEST CONDITIONS	MIN	TYP	MAX	UNIT
$V_{(VCAP)} - V_{(VS)}$	Charge Pump Enable comparator Hysteresis		0.45	0.8	1.25	V
$V_{(VCAP\ UVLO)}$	$V_{(VCAP)} - V_{(S)}$ UV release at rising edge		5.7	6.5	7.5	V
$V_{(VCAP\ UVLO)}$	$V_{(VCAP)} - V_{(S)}$ UV threshold at falling edge		5.05	5.4	6.2	V
<b>OVERVOLTAGE PROTECTION</b>						
$V_{(OVR)}$	Overvoltage threshold input, rising		1.165	1.25	1.333	V
$V_{(OVF)}$	Overvoltage threshold input, falling		1.063	1.143	1.222	V
$V_{(OV\_Hys)}$	OV Hysteresis			100		mV
$I_{(OV)}$	OV Input leakage current	$0\text{ V} < V_{(OV)} < 5\text{ V}$	12	50	110	nA

(1) Product preview

## 6.6 Switching Characteristics

$T_J = -40^\circ\text{C}$  to  $+125^\circ\text{C}$ ; typical values at  $T_J = 25^\circ\text{C}$ ,  $V_{(VS)} = 12\text{ V}$ ,  $C_{IN} = C_{(VCAP)} = C_{OUT} = 0.1\ \mu\text{F}$ ,  $V_{(EN/UVLO)} = 3.3\text{ V}$ , over operating free-air temperature range (unless otherwise noted)

PARAMETER		TEST CONDITIONS	MIN	TYP	MAX	UNIT
$EN_{TDLY}$	EN high to Gate Turn On delay	$V_{(VCAP)} > V_{(VCAP\ UVLO)}$ , $V_{(EN/UVLO)} > V_{(EN\_UVLO)}$ to $V_{(GATE-SRC)} > 5\text{ V}$ , $C_{(GATE-SRC)} = 4.7\text{ nF}$ LM74502H (1)		75	110	$\mu\text{s}$
$t_{UVLO\_OFF(deg\_)}_{GATE}$	GATE Turnoff delay during EN/UVLO	$V_{(EN/UVLO)} \downarrow$ to $V_{(GATE-SRC)} < 1\text{ V}$ , $C_{(GATE-SRC)} = 4.7\text{ nF}$		2		$\mu\text{s}$
$t_{OVP\_OFF(deg\_)}_{GATE}$	GATE Turnoff delay during OV	$V_{(OV)} \uparrow$ to $V_{(GATE-SRC)} < 1\text{ V}$ , $C_{(GATE-SRC)} = 4.7\text{ nF}$		0.6	1	$\mu\text{s}$
$t_{OVP\_ON(deg\_)}_{GATE}$	GATE Turnon delay during OV	$V_{(OV)} \downarrow$ to $V_{(GATE-SRC)} > 5\text{ V}$ , $C_{(GATE-SRC)} = 4.7\text{ nF}$ LM74502H (1)		7	10	$\mu\text{s}$

(1) Product preview

## 6.7 Typical Characteristics



图 6-1. Shutdown Supply Current vs Supply Voltage



图 6-2. Operating Quiescent Current vs Supply Voltage

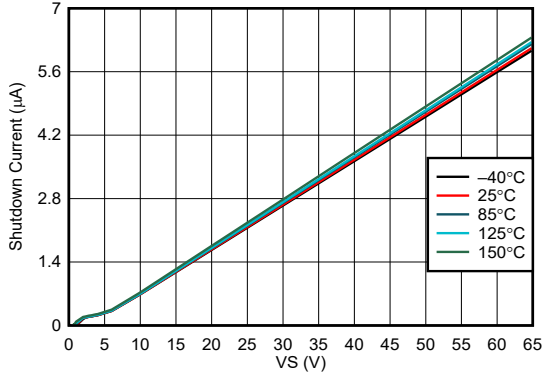

图 6-3. Charge Pump Current vs Supply Voltage at  $V_{CAP} = 6\text{ V}$

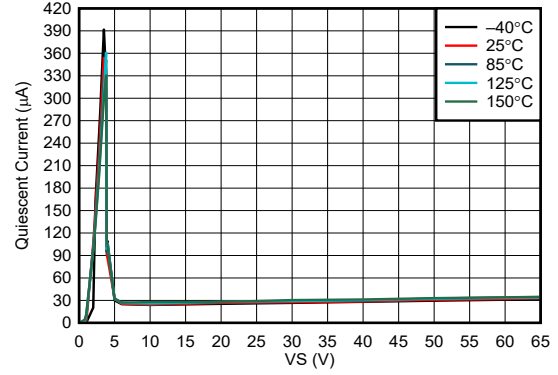

图 6-4. Charge Pump V-I Characteristics at  $V_S \geq 12\text{ V}$

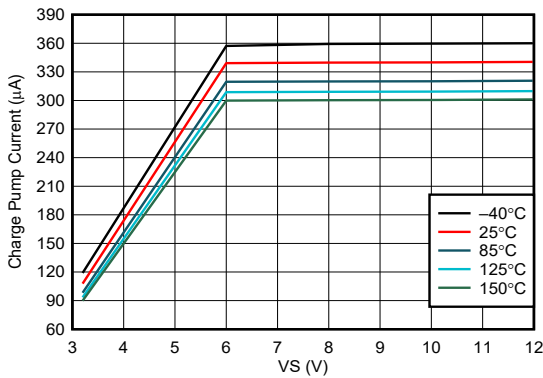

图 6-5. Charge Pump V-I Characteristics at  $V_S = 3.2\text{ V}$

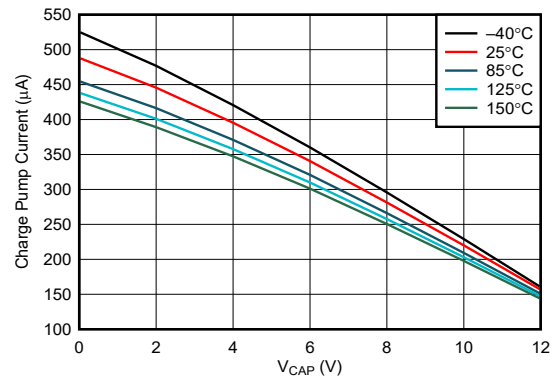

图 6-6. EN/UVLO Rising and Falling threshold vs Temperature

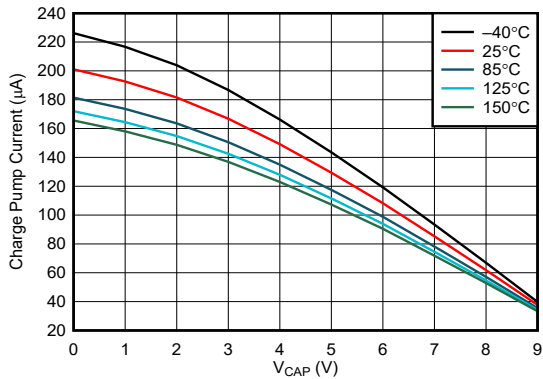

图 6-7. Enable to Gate Delay vs Temperature (LM74502H)

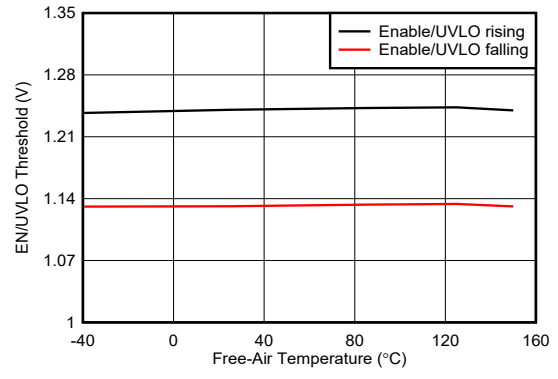

图 6-8. Charge Pump ON/OFF Threshold vs Temperature

### 6.7 Typical Characteristics (continued)

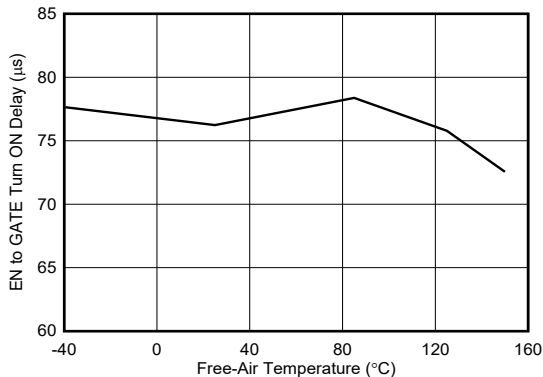

图 6-9. Charge Pump UVLO Threshold vs Temperature

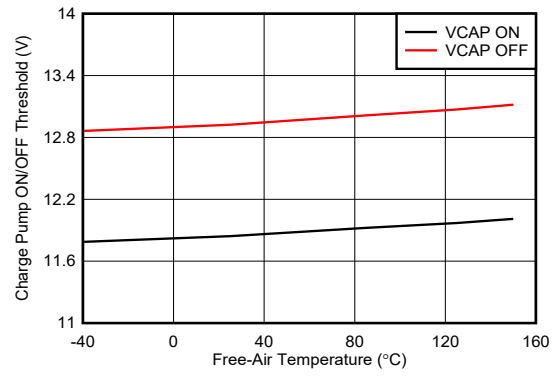

图 6-10. VS POR Threshold vs Temperature

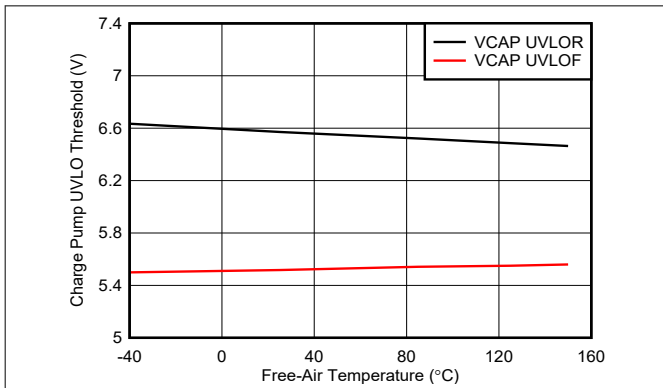

图 6-11. OV Comparator Threshold vs Temperature

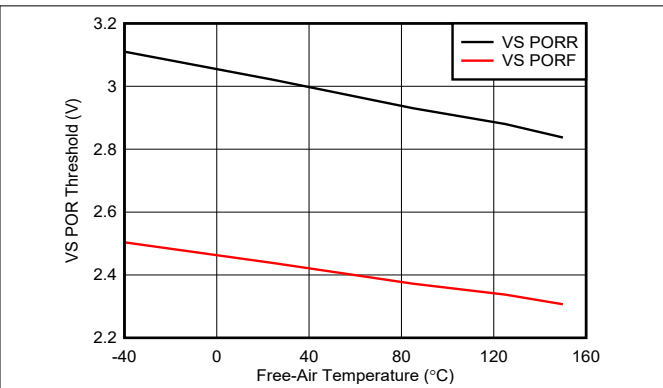

图 6-12. OV to GATE Delay vs Temperature (LM74502H)

## 7 Parameter Measurement Information

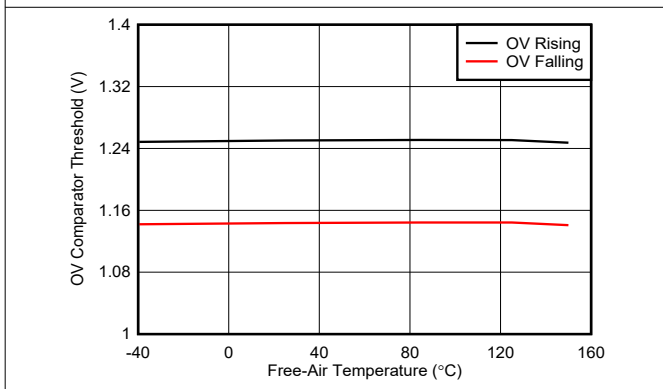

图 7-1. Timing Waveforms

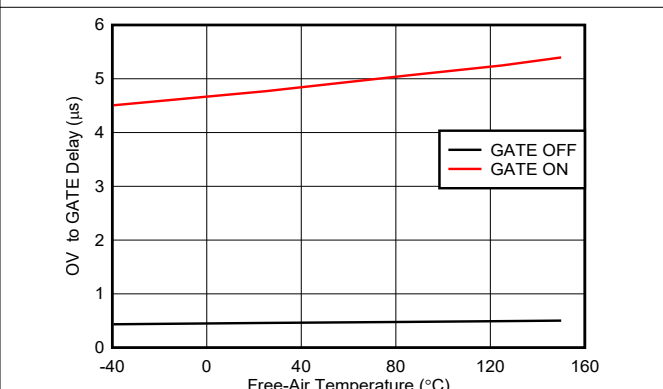
## 8 Detailed Description

### 8.1 Overview

The LM74502 and LM74502H controller has all the features necessary to implement an efficient and fast reverse polarity protection circuit with load disconnect feature. This easy to use reverse polarity protection controller is paired with an external back-to-back connected N-channel MOSFETs to replace other reverse polarity schemes such as a P-channel MOSFETs. The wide input supply range of 4 V to 65 V allows protection and control of 12-V and 24-V input supply systems. The device can withstand and protect the loads from negative supply voltages down to  $-65$  V. An integrated charge pump drives external back-to-back connected N-channel MOSFETs with gate drive voltage of approximately 13 V. LM74502 with its 60- $\mu$ A peak gate drive strength is suitable for applications that need inherent inrush current control. LM74502H with its fast gate drive strength of 11-mA peak is suitable for applications which need fast turn-on and turn-off of external MOSFET switch. LM74502 features an adjustable overvoltage protection using the OV pin. With the enable pin low during the standby mode, both the external MOSFETs and controller is off and draws a very low shutdown current of 1  $\mu$ A.

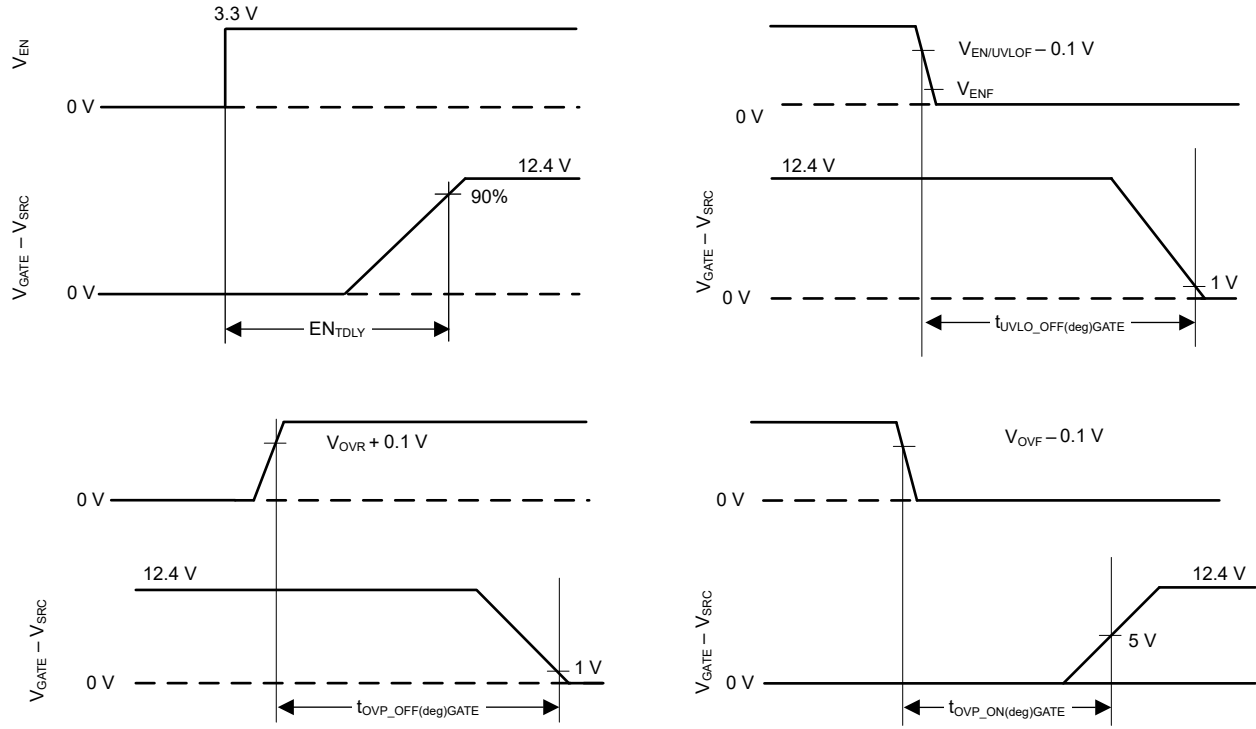
### 8.2 Functional Block Diagram

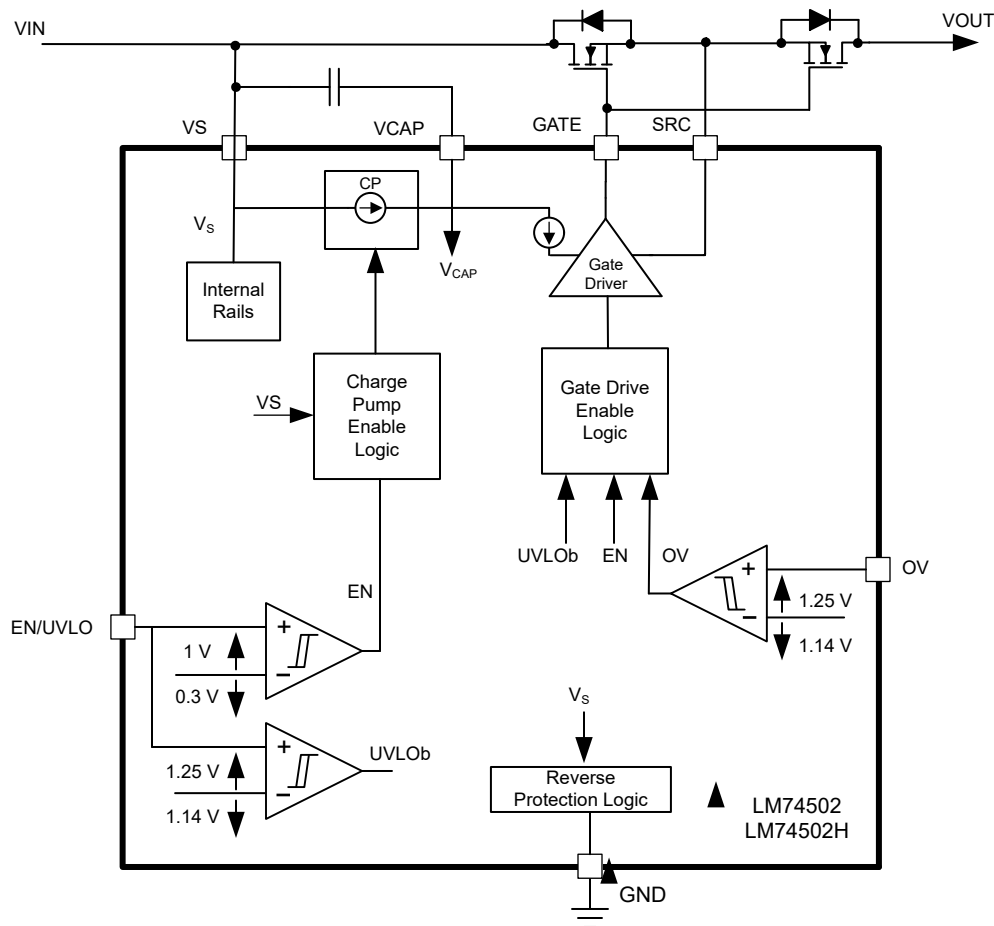

### 8.3 Feature Description

#### 8.3.1 Input Voltage

The VS pin is used to power the LM74502's internal circuitry, typically drawing 45  $\mu$ A when enabled and 1  $\mu$ A when disabled. If the VS pin voltage is greater than the POR Rising threshold, then LM74502 operates in either shutdown mode or conduction mode in accordance with the EN/UVLO pin voltage. The voltage from VS to GND is designed to vary from 65 V to  $-65$  V, allowing the LM74502 to withstand negative voltage transients.

### 8.3.2 Charge Pump (VCAP)

The charge pump supplies the voltage necessary to drive the external N-channel MOSFET. An external charge pump capacitor is placed between VCAP and VS pin to provide energy to turn on the external MOSFET. For the charge pump to supply current to the external capacitor the EN/UVLO pin voltage must be above the specified input high threshold,  $V_{(EN\_IH)}$ . When enabled the charge pump sources a charging current of 300  $\mu\text{A}$  typically. If EN/UVLO pins is pulled low, then the charge pump remains disabled. To ensure that the external MOSFET can be driven above its specified threshold voltage, the VCAP to VS voltage must be above the undervoltage lockout threshold, typically 6.5 V, before the internal gate driver is enabled. Use [方程式 1](#) to calculate the initial gate driver enable delay.

$$T_{(DRV\_EN)} = 75 \mu\text{s} + C_{(VCAP)} \times \frac{V_{(VCAP\_UVLOR)}}{300 \mu\text{A}} \quad (1)$$

where

- $C_{(VCAP)}$  is the charge pump capacitance connected across VS and VCAP pins
- $V_{(VCAP\_UVLOR)} = 6.5 \text{ V}$  (typical)

To remove any chatter on the gate drive approximately 800 mV of hysteresis is added to the VCAP undervoltage lockout. The charge pump remains enabled until the VCAP to VS voltage reaches 12.4 V, typically, at which point the charge pump is disabled decreasing the current draw on the VS pin. The charge pump remains disabled until the VCAP to VS voltage is below to 11.6 V typically at which point the charge pump is enabled. The voltage between VCAP and VS continue to charge and discharge between 11.6 V and 12.4 V as shown in [图 8-1](#). By enabling and disabling the charge pump, the operating quiescent current of the LM74502 is reduced. When the charge pump is disabled it sinks 5- $\mu\text{A}$  typical.



图 8-1. Charge Pump Operation

### 8.3.3 Gate Driver (GATE, SRC)

The gate driver is used to control the external N-Channel MOSFET by setting the appropriate GATE to SRC voltage.

Before the gate driver is enabled, the following three conditions must be achieved:

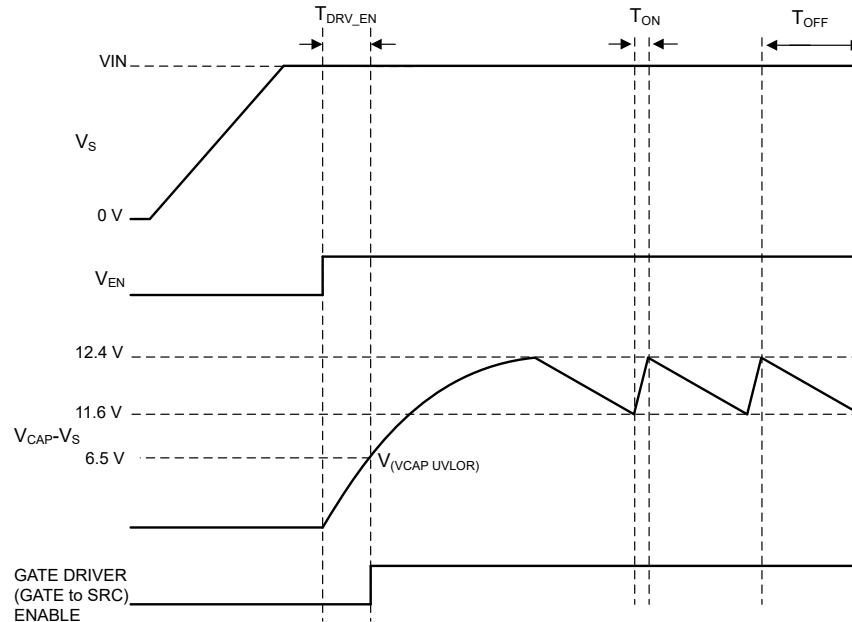
- The EN/UVLO pin voltage must be greater than the specified input high voltage.
- The VCAP to VS voltage must be greater than the undervoltage lockout voltage.

- The VS voltage must be greater than VS POR rising threshold.

If the above conditions are not achieved, then the GATE pin is internally connected to the SRC pin, assuring that the external MOSFET is disabled. After these conditions are achieved, the gate driver operates in the conduction mode enhancing the external MOSFET completely.

The controller offers two gate drive variants. LM74502 with typical peak gate drive strength of 60  $\mu$ A is suitable to achieve smooth start-up with inherent inrush current control due to its lower gate drive strength.

LM74502H with its 11 -A typical peak gate drive strength is suitable for applications which need faster turn on such as load switch applications.

LM74502, LM74502H SRC pin is capable of handling negative voltage which also makes it suitable for load disconnect switch applications with loads which are inductive in nature.

### 8.3.3.1 Inrush Current Control

An external circuit as shown in [图 8-2](#) can be added on the GATE pin of the LM74502 to have additional inrush current control for the applications which have large capacitive loads.

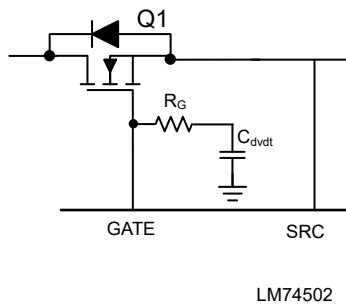

**图 8-2. Inrush Current Limiting Using LM74502**

The  $C_{dVdT}$  capacitor is required for slowing down the GATE voltage ramp during power up for inrush current limiting. Use [方程式 2](#) to calculate  $C_{dVdT}$  capacitance value.

$$C_{dVdT} = \frac{I_{GATE} \times C_{OUT}}{I_{INRUSH}} \quad (2)$$

where  $I_{GATE}$  is 60  $\mu$ A (typical),  $I_{INRUSH}$  is the inrush current and  $C_{OUT}$  is the output load capacitance. An extra resistor,  $R_G$ , in series with the  $C_{dVdT}$  capacitor acts as an isolation resistor between  $C_{dVdT}$  and gate of the MOSFET.

The inrush current control scheme shown in [图 8-2](#) is not applicable to LM74502H as its gate drive is optimized for fast turn-on load switch applications.

### 8.3.4 Enable (EN/UVLO)

The LM74502 has an enable pin, EN/UVLO. The enable pin allows for the gate driver to be either enabled or disabled by an external signal. If the EN/UVLO pin voltage is greater than the rising threshold, the gate driver and charge pump operates as described in the [Gate Driver \(GATE, SRC\)](#) and [Charge Pump \(VCAP\)](#) sections. If the enable pin voltage is less than the input low threshold, the charge pump and gate driver are disabled placing the LM74502 in shutdown mode. The EN/UVLO pin can withstand a voltage as large as 65 V and as low as -65 V. This feature allows for the EN/UVLO pin to be connected directly to the VS pin if enable functionality is not needed. In conditions where EN/UVLO is left floating, the internal sink current of 3  $\mu$ A pulls EN/UVLO pin low and disables the device.

An external resistor divider connected from input to EN/UVLO to ground can be used to implement the input Undervoltage Lockout (UVLO) functionality in the system. When EN/UVLO pin voltage is lower than UVLO comparator falling threshold ( $V_{EN/UVLOR}$ ) but higher than enable falling threshold ( $V_{ENF}$ ), the device disables gate

drive voltage, however, charge pump is kept on. This action ensures quick recovery of gate drive when UVLO condition is removed. If UVLO functionality is not required, connect EN/UVLO pin to VS.

### 8.3.5 Overvoltage Protection (OV)

LM74502 provides programmable overvoltage protection feature with OV pin. A resistor divider can be connected from input source to OV pin to ground in order to set overvoltage threshold. An internal comparator compares the input voltage against fixed reference (1.25 V) and disables the gate drive as soon as OV pin voltage goes above the OV comparator reference. When the resistor divider is referred from input supply side, device is configured for overvoltage cut-off functionality. When the resistor divider is referred from output side ( $V_{OUT}$ ), the device is configured for overvoltage clamp functionality.

When OV pin voltage goes above OV comparator  $V_{OVR}$  threshold (1.25-V typical), the device disables gate drive, however, charge pump remains active. When OV pin voltage falls below  $V_{OVF}$  threshold (1.14-V typical), the gate is quickly turned on as charge pump is kept on and the device does not go through the device start-up process. When OV pin is not used, it can be connected to ground.

## 8.4 Device Functional Modes

### 8.4.1 Shutdown Mode

The LM74502 enters shutdown mode when the EN/UVLO pin voltage is below the specified input low threshold  $V_{(ENF)}$ . Both the gate driver and the charge pump are disabled in shutdown mode. During shutdown mode the LM74502 enters low  $I_Q$  operation with the VS pin only sinking 1  $\mu$ A of current.

### 8.4.2 Conduction Mode

For the LM74502 to operate in conduction mode the gate driver must be enabled as described in the [Gate Driver \(GATE, SRC\)](#) section. If these conditions are achieved the GATE pin is

- Internally driven through 60-  $\mu$  A current source in case of LM74502
- Internally connected to the VCAP for fast turn-on of external FET in case of LM74502H

LM74502, LM74502H gate drive is disabled when OV pin voltage is above  $V_{OVR}$  threshold or EN/UVLO pin voltage is lower than  $V_{EN/UVLOF}$  threshold.

## 9 Application and Implementation

### 备注

Information in the following applications sections is not part of the TI component specification, and TI does not warrant its accuracy or completeness. TI's customers are responsible for determining suitability of components for their purposes, as well as validating and testing their design implementation to confirm system functionality.

### 9.1 Application Information

The LM74502 is used with back-to-back connected N-Channel MOSFETs in a typical reverse polarity protection with load disconnect application. The schematic for the 12-V input supply reverse polarity protection is shown in [图 9-1](#), where the LM74502 is used to drive the back-to-back connected MOSFETs Q1 and Q2 in series with a 12-V supply.

### 9.2 Typical Application



图 9-1. Typical Application Circuit

#### 9.2.1 Design Requirements

A design example, with system design parameters listed in [表 9-1](#) is presented.

表 9-1. Design Parameters

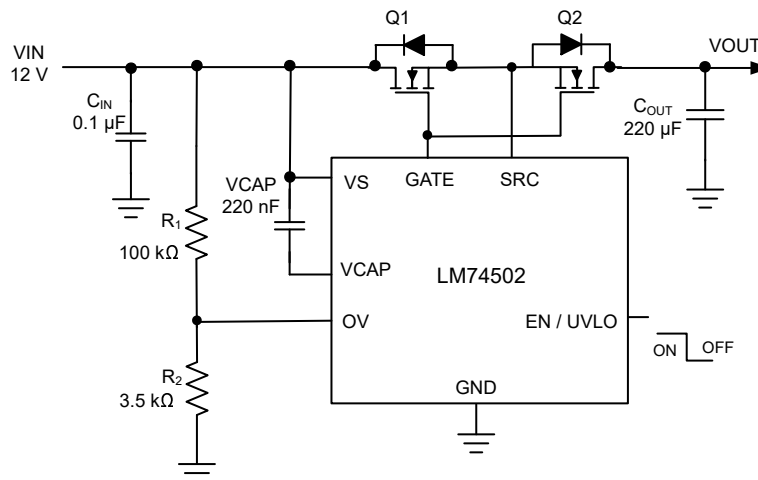
DESIGN PARAMETER	EXAMPLE VALUE
Input voltage range	12-V nominal
Overvoltage protection	37 V
Output current	5-A full load
Output capacitance	220-μF typical output capacitance

#### 9.2.2 Detailed Design Procedure

##### 9.2.2.1 Design Considerations

- Input operating voltage range (including overvoltage protection)
- Maximum load current

##### 9.2.2.2 MOSFET Selection

The important MOSFET electrical parameters are the maximum continuous drain current  $I_D$ , the maximum drain-to-source voltage  $V_{DS(MAX)}$ , the maximum gate-to-source voltage  $V_{GS(MAX)}$  and the drain-to-source On resistance  $R_{DSON}$ .

The maximum continuous drain current,  $I_D$ , rating must exceed the maximum continuous load current. The maximum drain-to-source voltage,  $V_{DS(MAX)}$ , must be high enough to withstand the highest differential voltage seen in the application. This requirement would include any anticipated fault conditions. The maximum  $V_{GS}$  LM74502 can drive is 13.9 V, so a MOSFET with 15-V minimum  $V_{GS}$  rating must be selected. If a MOSFET with  $V_{GS}$  rating < 15 V is selected, a zener diode can be used between GATE to SRC pin to clamp  $V_{GS}$  to safe level.

To reduce the MOSFET conduction losses, lowest possible  $R_{DS(ON)}$  is preferred. Selecting a MOSFET with  $R_{DS(ON)}$  that gives VDS drop 20 mV to 50 mV provides good trade off in terms of power dissipation and cost.

Thermal resistance of the MOSFET must be considered against the expected maximum power dissipation in the MOSFET to ensure that the junction temperature ( $T_J$ ) is well controlled.

### 9.2.2.3 Overvoltage Protection

Resistors R1 and R2 connected in series is used to program the overvoltage threshold. Connecting R1 to VIN provides overvoltage cut-off and switching the connection to VOUT provides overvoltage clamp response. The resistor values required for setting the overvoltage threshold  $V_{OV}$  to 37 V are calculated by solving [方程式 3](#)

$$V_{OVR} = \frac{R_3 \times V_{OV}}{R_2 + R_3} \quad (3)$$

For minimizing the input current drawn from the supply through resistors R1 and R2, it is recommended to use higher value of resistance. Using high value resistors adds error in the calculations because the current through the resistors at higher value becomes comparable to the leakage current into the OV pin. Select  $(R1 + R2)$  such that current through resistors is around 100 times higher than the leakage through OV pin. Based on the device electrical characteristics,  $V_{OVR}$  is 1.25 V, Select  $(R1) = 100 \text{ k}\Omega$  and  $R2 = 3.5 \text{ k}\Omega$  as a standard resistor value to set overvoltage cutoff of 37 V.

### 9.2.2.4 Charge Pump VCAP, Input and Output Capacitance

Minimum required capacitance for charge pump VCAP and input and output capacitance are:

- $C_{VCAP}$ : minimum recommended value of VCAP ( $\mu\text{F}$ )  $\geq 10 \times$  Effective  $C_{ISS(MOSFET)}$  ( $\mu\text{F}$ ), 0.22  $\mu\text{F}$  is selected
- $C_{IN}$ : typical input capacitor of 0.1  $\mu\text{F}$
- $C_{OUT}$ : typical output capacitor 220  $\mu\text{F}$

### 9.2.3 Application Curves

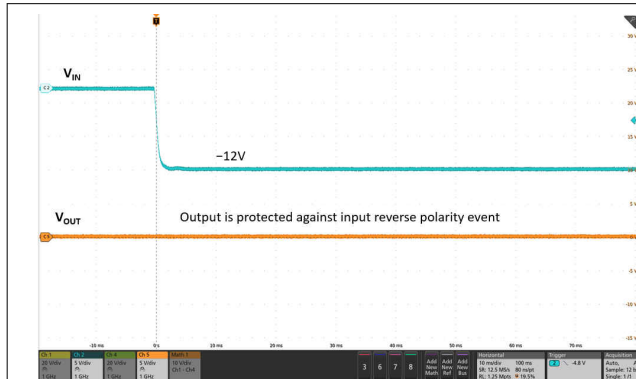

Time (10 ms/DIV)

图 9-2. Start-up With Reverse Voltage - 12 V

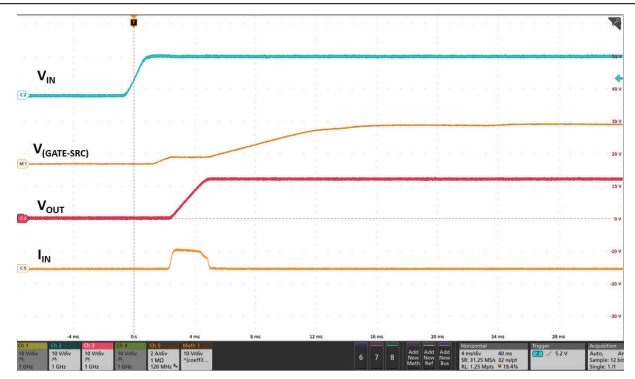

Time (4 ms/DIV)

图 9-3. Start-up With No Load

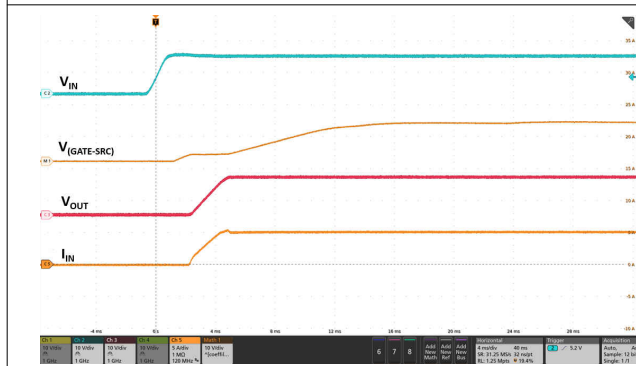

Time (4 ms/DIV)

图 9-4. Start-up With 5-A Load

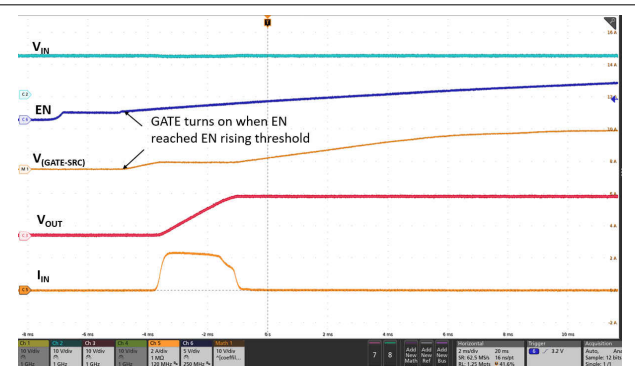

Time (2 ms/DIV)

图 9-5. Start-up With EN Control

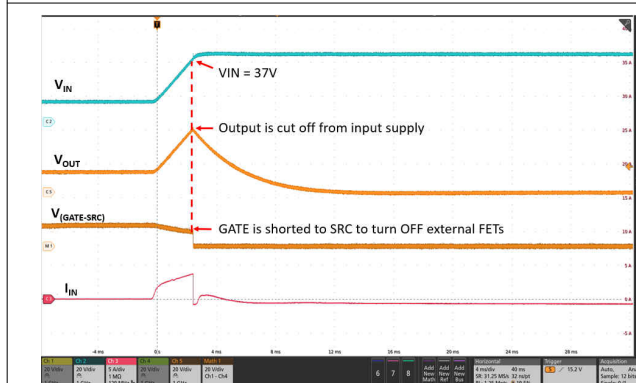

Time (4 ms/DIV)

图 9-6. Overvoltage Cut-off Response (37 V)

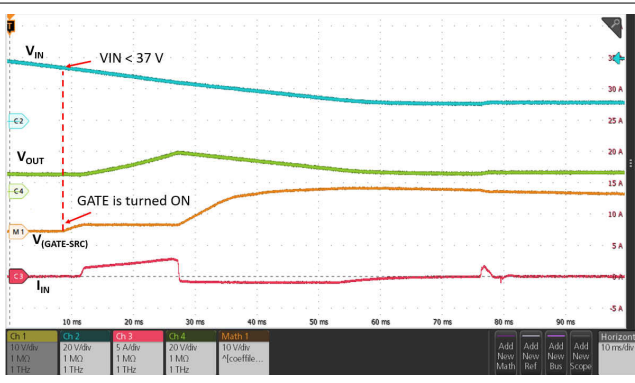

Time (10 ms/DIV)

图 9-7. Overvoltage Recovery

### 9.3 Input Surge Stopper Using LM74502, LM74502H

Many industrial applications need to comply with input overvoltage transients and surge events specified by standards such as IEC61000-4-x. LM74502, LM74502H can be configured as input surge stopper to provide overvoltage along with input reverse supply protection.



图 9-8. Typical Surge Stopper Application for 24-V Powered Systems

As shown in 图 9-8 MOSFET Q1 is used to turn off or clamp output voltage to acceptable safe level and protect the MOSFET Q2 and LM74502 from input transient. Note that only the VS pin is exposed to input transient through a resistor, R1. A 60-V rated zener diode is used to clamp and protect the VS pin within recommended operating condition. Rest of the circuit is not exposed to higher voltage as the MOSFET Q1 can either be turned off completely or output voltage clamped to safe level.

#### 9.3.1 VS Capacitance, Resistor R<sub>1</sub> and Zener Clamp (D<sub>Z</sub>)

Minimum of 1 μF C<sub>VS</sub> capacitance is required. During input overvoltage transient, resistor R1 and zener diode D<sub>Z</sub> are used to protect VS pin from exceeding the maximum ratings by clamping V<sub>VS</sub> to 60 V. Choosing R1 = 10 kΩ, the peak power dissipated in zener diode D<sub>Z</sub> can be calculated using 方程式 4.

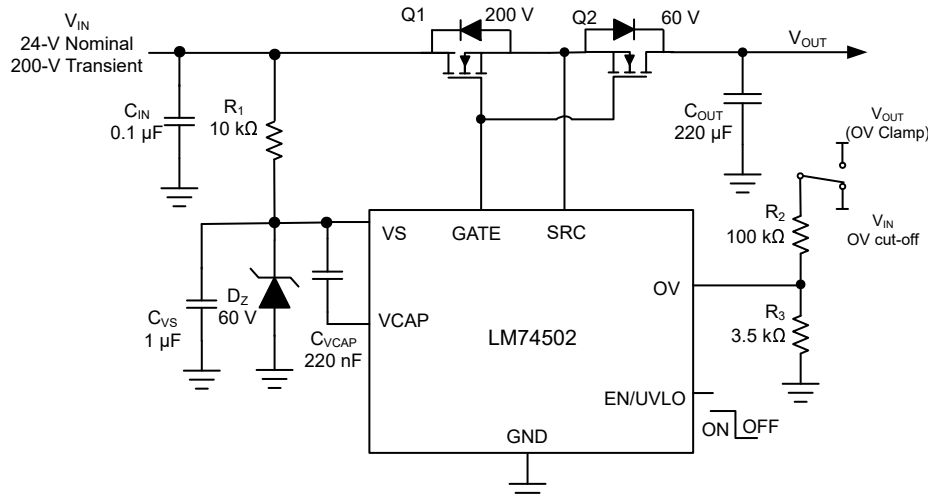
$$P_{DZ} = V_{DZ} \times \frac{(V_{IN(MAX)} - V_{DZ})}{R_1} \quad (4)$$

Where V<sub>DZ</sub> is the breakdown voltage of zener diode. Select the zener diode which can handle peak power requirement.

Peak power dissipated in resistor R1 can be calculated using 方程式 5.

$$P_{R1} = \frac{(V_{IN(MAX)} - V_{DZ})^2}{R_1} \quad (5)$$

Select a resistor package which can handle peak power and maximum DC voltage.

#### 9.3.2 Overvoltage Protection

For the overvoltage setting, refer to the resistor selection procedure described in [Overvoltage Protection](#). Select (R2) = 100 kΩ and R3 = 3.5 kΩ as a standard resistor value to set overvoltage cut-off of 37 V.

#### 9.3.3 MOSFET Selection

The VDS rating of the MOSFET Q1 must be minimum V<sub>IN(max)</sub> for designs with output overvoltage cut-off where output can reach 0 V with higher loads. For designs with output overvoltage clamp, MOSFET VDS rating must

be  $(V_{IN(max)} - V_{OUT\_CLAMP})$ . The VGS rating is based on GATE-SRC maximum voltage of 15 V. TI recommends a 20-V VGS rated MOSFET. Power dissipation on MOSFET Q1 on a design where output is clamped is critical and SOA characteristics of the MOSFET must be considered with sufficient design margin for reliable operation. An additional zener diode from GATE to SRC can be needed to protect the external FET in case output is expected to drop to the level where it can exceed external FET  $V_{GS(max)}$  rating.



图 9-9. 200-V Surge Stopper With Overvoltage Cut-off Using LM74502

#### 9.4 Fast Turn-On and Turn-Off High Side Switch Driver Using LM74502H

In applications such as industrial motor drives and safety power line communication digital output modules, N-Channel MOSFET based high side switch is very commonly used to disconnect the loads from supply line in case of faults such as overvoltage event. LM74502, LM74502H can be used to drive external MOSFET to realize simple high side switch with overvoltage protection. 图 9-10 shows a typical application circuit where LM74502H is used to drive external MOSFET Q1 as a main power path connect and disconnect switch. A resistor divider from input to OV pin to ground can be used to set the overvoltage threshold.

If VOUT node (SRC pin) of the device is expected to drop in case of events such as overcurrent or short-circuit on load side then additional zener diode is required across gate and source pin of external MOSFET to protect it from exceeding its maximum  $V_{GS}$  rating.

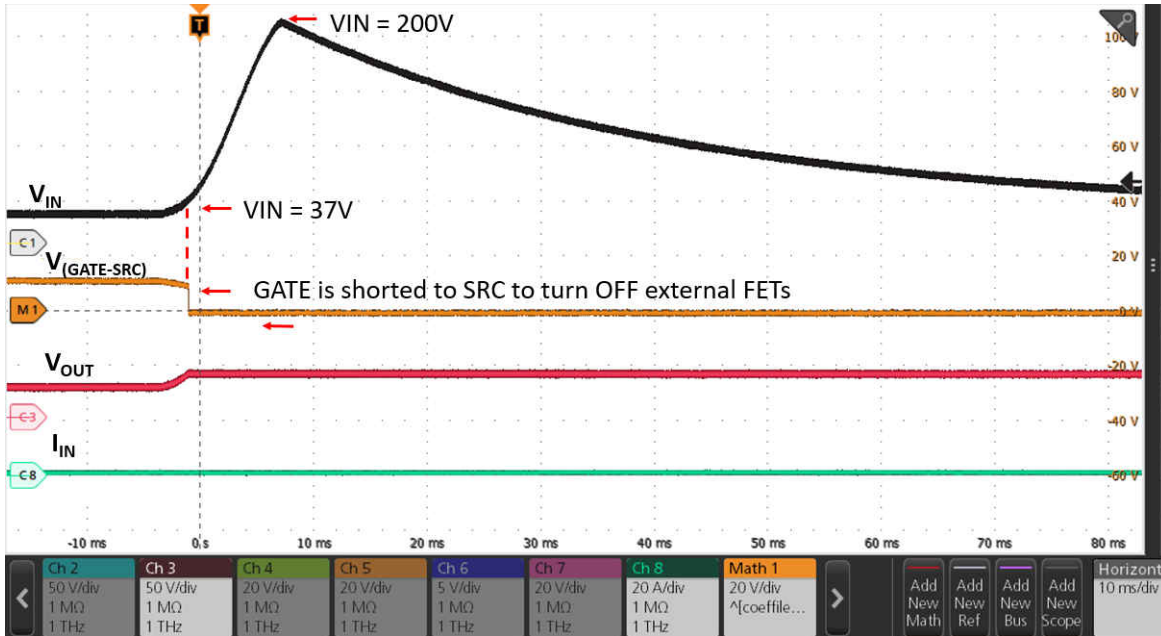

图 9-10. Fast Turn-ON and OFF High Side Switch Using LM74502H

Many industrial safety applications require fast switching off of MOSFET to verify proper functioning of the high side disconnect switch for diagnostic purpose. LM74502H OV pin can be used as control input to realize fast turn-on and turn-off load switch functionality. With OV pin pulled above  $V_{OVR}$  threshold of (1.25-V typical), LM74502H turns off the external MOSFET (with  $C_{iss} = 4.7$  nF) within 1  $\mu$ s typically. When OV pin is pulled low, LM74502H with its peak gate drive strength of 11 mA turns on external MOSFET with turn on speed of 7-  $\mu$ s typical. 图 9-11 shows LM74502H GATE to SRC response when OV pin is toggled with 300-  $\mu$ s pulse.

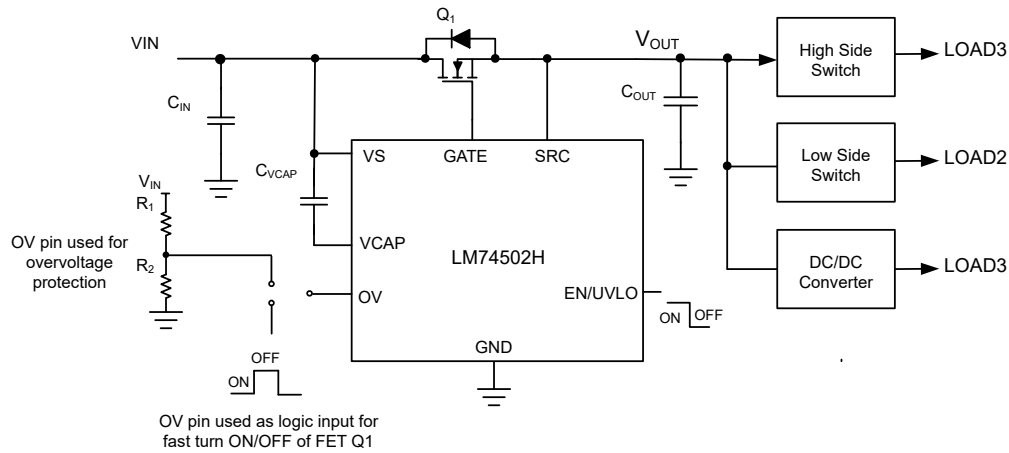

图 9-11. Fast Turn-On and Turn-Off High Side Switch Driver Using LM74502H

## 10 Power Supply Recommendations

The LM74502, LM74502H reverse polarity protection controller is designed for the supply voltage range of 3.2 V  $\leq V_S \leq 65$  V. If the input supply is located more than a few inches from the device, TI recommends an input ceramic bypass capacitor higher than 0.1  $\mu$ F. Based on system requirements, a higher input bypass capacitor may be needed with LM74502H to avoid supply glitch in case of high inrush current start-up event. To prevent LM74502 and surrounding components from damage under the conditions of a direct output short circuit, use a power supply having overload and short-circuit protection.

## 11 Layout

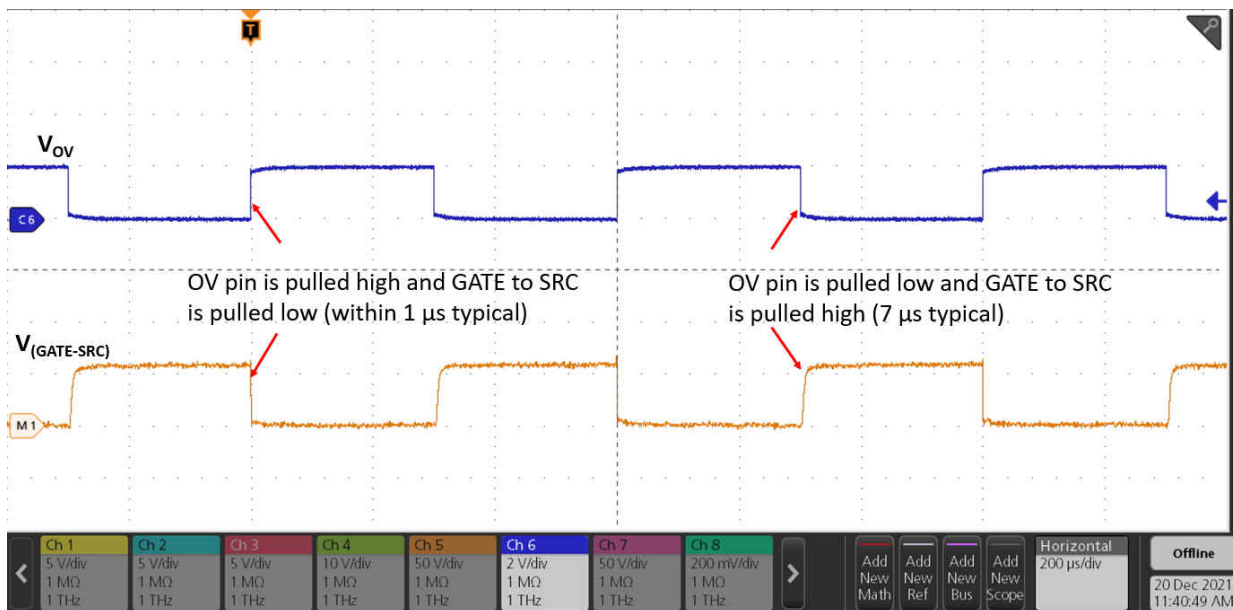
### 11.1 Layout Guidelines

- Place the input capacitor  $C_{IN}$  of 0.1-  $\mu$ F minimum close to VS pin to ground. This typically helps with better EMI performance.
- Connect GATE and SRC pin of LM74502, LM74502H close to the MOSFET's GATE and SOURCE pin.
- Use thick traces for source and drain of the MOSFET to minimize resistive losses because the high current path of for this solution is through the MOSFET.
- The charge pump capacitor across VCAP and VS pin must be kept away from the MOSFET to lower the thermal effects on the capacitance value.
- The GATE pin of the LM74502, LM74502H must be connected to the MOSFET gate with short trace. Avoid excessively thin and long running trace to the Gate Drive.

### 11.2 Layout Example



图 11-1. Layout Example

## 12 Device and Documentation Support

### 12.1 接收文档更新通知

要接收文档更新通知，请导航至 [ti.com](https://www.ti.com) 上的器件产品文件夹。点击 [订阅更新](#) 进行注册，即可每周接收产品信息更改摘要。有关更改的详细信息，请查看任何已修订文档中包含的修订历史记录。

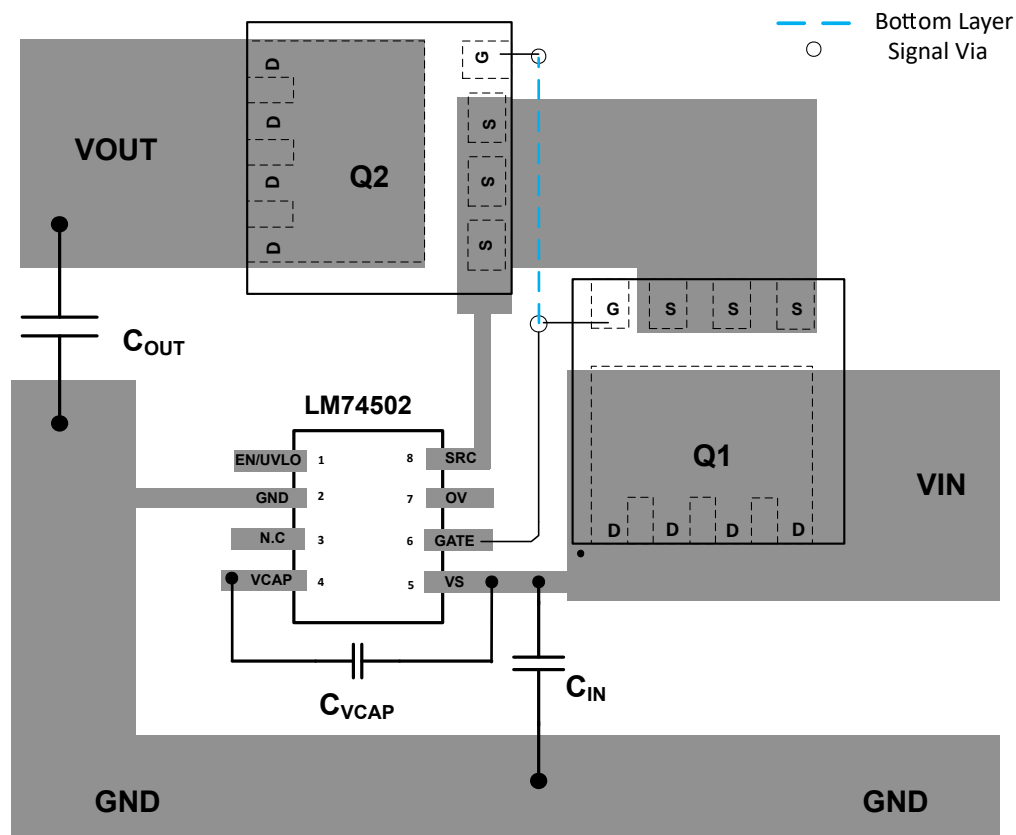
### 12.2 支持资源

**TI E2E™ 支持论坛**是工程师的重要参考资料，可直接从专家获得快速、经过验证的解答和设计帮助。搜索现有解答或提出自己的问题可获得所需的快速设计帮助。

链接的内容由各个贡献者“按原样”提供。这些内容并不构成 TI 技术规范，并且不一定反映 TI 的观点；请参阅 TI 的《[使用条款](#)》。

### 12.3 Trademarks

TI E2E™ is a trademark of Texas Instruments.  
所有商标均为其各自所有者的财产。

### 12.4 Electrostatic Discharge Caution



This integrated circuit can be damaged by ESD. Texas Instruments recommends that all integrated circuits be handled with appropriate precautions. Failure to observe proper handling and installation procedures can cause damage.

ESD damage can range from subtle performance degradation to complete device failure. Precision integrated circuits may be more susceptible to damage because very small parametric changes could cause the device not to meet its published specifications.

### 12.5 术语表

[TI 术语表](#) 本术语表列出并解释了术语、首字母缩略词和定义。

## 13 Mechanical, Packaging, and Orderable Information

The following pages include mechanical, packaging, and orderable information. This information is the most current data available for the designated devices. This data is subject to change without notice and revision of this document. For browser-based versions of this data sheet, refer to the left-hand navigation.

**PACKAGING INFORMATION**

Orderable Device	Status (1)	Package Type	Package Drawing	Pins	Package Qty	Eco Plan (2)	Lead finish/ Ball material (6)	MSL Peak Temp (3)	Op Temp (°C)	Device Marking (4/5)	Samples
LM74502DDFR	ACTIVE	SOT-23-THIN	DDF	8	3000	RoHS & Green	NIPDAU	Level-1-260C-UNLIM	-40 to 125	LM502	Samples

(1) The marketing status values are defined as follows:

**ACTIVE:** Product device recommended for new designs.

**LIFEBUY:** TI has announced that the device will be discontinued, and a lifetime-buy period is in effect.

**NRND:** Not recommended for new designs. Device is in production to support existing customers, but TI does not recommend using this part in a new design.

**PREVIEW:** Device has been announced but is not in production. Samples may or may not be available.

**OBSOLETE:** TI has discontinued the production of the device.

(2) **RoHS:** TI defines "RoHS" to mean semiconductor products that are compliant with the current EU RoHS requirements for all 10 RoHS substances, including the requirement that RoHS substance do not exceed 0.1% by weight in homogeneous materials. Where designed to be soldered at high temperatures, "RoHS" products are suitable for use in specified lead-free processes. TI may reference these types of products as "Pb-Free".

**RoHS Exempt:** TI defines "RoHS Exempt" to mean products that contain lead but are compliant with EU RoHS pursuant to a specific EU RoHS exemption.

**Green:** TI defines "Green" to mean the content of Chlorine (Cl) and Bromine (Br) based flame retardants meet JS709B low halogen requirements of <=1000ppm threshold. Antimony trioxide based flame retardants must also meet the <=1000ppm threshold requirement.

(3) MSL, Peak Temp. - The Moisture Sensitivity Level rating according to the JEDEC industry standard classifications, and peak solder temperature.

(4) There may be additional marking, which relates to the logo, the lot trace code information, or the environmental category on the device.

(5) Multiple Device Markings will be inside parentheses. Only one Device Marking contained in parentheses and separated by a "-" will appear on a device. If a line is indented then it is a continuation of the previous line and the two combined represent the entire Device Marking for that device.

(6) Lead finish/Ball material - Orderable Devices may have multiple material finish options. Finish options are separated by a vertical ruled line. Lead finish/Ball material values may wrap to two lines if the finish value exceeds the maximum column width.

**Important Information and Disclaimer:**The information provided on this page represents TI's knowledge and belief as of the date that it is provided. TI bases its knowledge and belief on information provided by third parties, and makes no representation or warranty as to the accuracy of such information. Efforts are underway to better integrate information from third parties. TI has taken and continues to take reasonable steps to provide representative and accurate information but may not have conducted destructive testing or chemical analysis on incoming materials and chemicals. TI and TI suppliers consider certain information to be proprietary, and thus CAS numbers and other limited information may not be available for release.

In no event shall TI's liability arising out of such information exceed the total purchase price of the TI part(s) at issue in this document sold by TI to Customer on an annual basis.

# DDF0008A

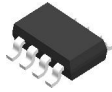

# PACKAGE OUTLINE

## SOT-23 - 1.1 mm max height

PLASTIC SMALL OUTLINE

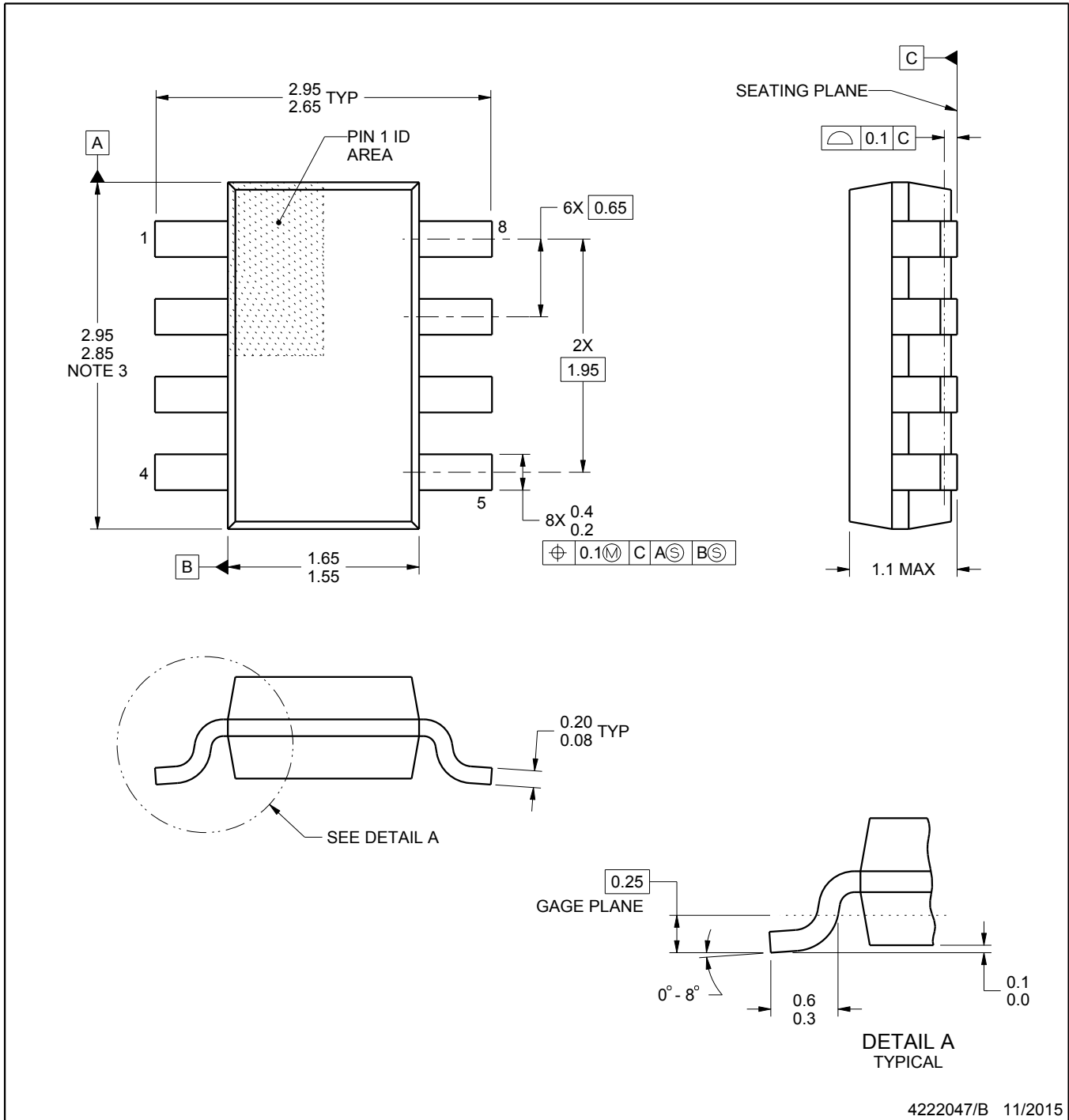

**NOTES:**

1. All linear dimensions are in millimeters. Any dimensions in parenthesis are for reference only. Dimensioning and tolerancing per ASME Y14.5M.
2. This drawing is subject to change without notice.
3. This dimension does not include mold flash, protrusions, or gate burrs. Mold flash, protrusions, or gate burrs shall not exceed 0.15 mm per side.

4222047/B 11/2015

# EXAMPLE BOARD LAYOUT

DDF0008A

SOT-23 - 1.1 mm max height

PLASTIC SMALL OUTLINE

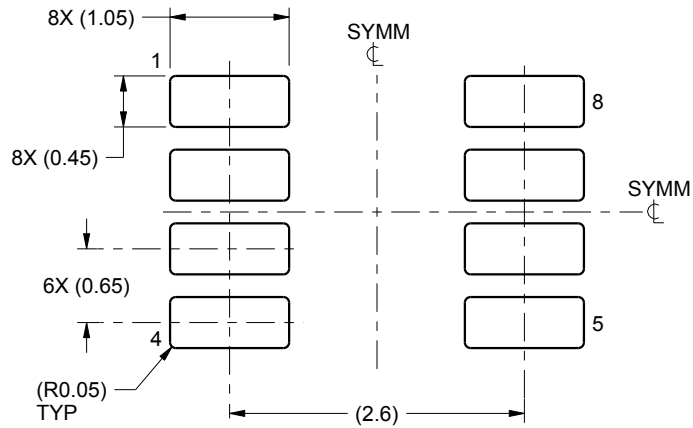

LAND PATTERN EXAMPLE  
SCALE:15X

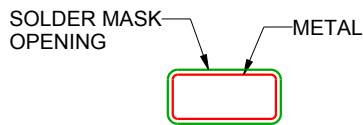

NON SOLDER MASK  
DEFINED

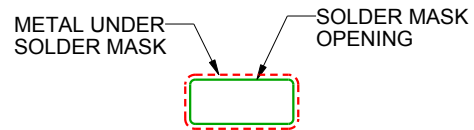

SOLDER MASK  
DEFINED

SOLDER MASK DETAILS

4222047/B 11/2015

NOTES: (continued)

4. Publication IPC-7351 may have alternate designs.
5. Solder mask tolerances between and around signal pads can vary based on board fabrication site.

# EXAMPLE STENCIL DESIGN

DDF0008A

SOT-23 - 1.1 mm max height

PLASTIC SMALL OUTLINE

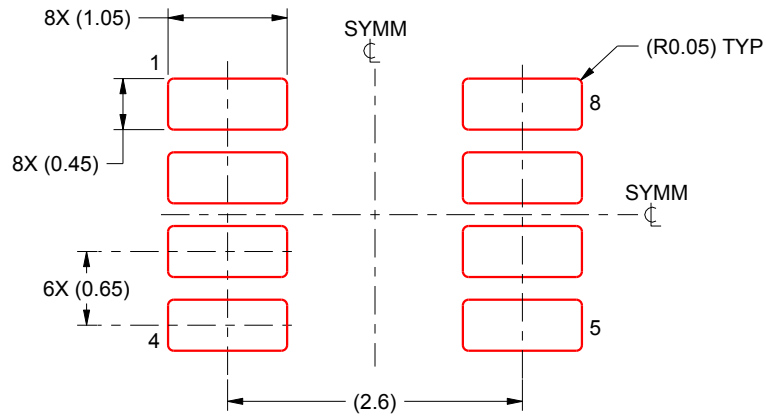

SOLDER PASTE EXAMPLE  
BASED ON 0.125 mm THICK STENCIL  
SCALE:15X

4222047/B 11/2015

NOTES: (continued)

6. Laser cutting apertures with trapezoidal walls and rounded corners may offer better paste release. IPC-7525 may have alternate design recommendations.
7. Board assembly site may have different recommendations for stencil design.

## 重要声明和免责声明

TI“按原样”提供技术和可靠性数据（包括数据表）、设计资源（包括参考设计）、应用或其他设计建议、网络工具、安全信息和其他资源，不保证没有瑕疵且不做任何明示或暗示的担保，包括但不限于对适销性、某特定用途方面的适用性或不侵犯任何第三方知识产权的暗示担保。

这些资源可供使用 TI 产品进行设计的熟练开发人员使用。您将自行承担以下全部责任：(1) 针对您的应用选择合适的 TI 产品，(2) 设计、验证并测试您的应用，(3) 确保您的应用满足相应标准以及任何其他功能安全、信息安全、监管或其他要求。

这些资源如有变更，恕不另行通知。TI 授权您仅可将这些资源用于研发本资源所述的 TI 产品的应用。严禁对这些资源进行其他复制或展示。您无权使用任何其他 TI 知识产权或任何第三方知识产权。您应全额赔偿因在这些资源的使用中对 TI 及其代表造成的任何索赔、损害、成本、损失和债务，TI 对此概不负责。

TI 提供的产品受 [TI 的销售条款](#) 或 [ti.com](#) 上其他适用条款/TI 产品随附的其他适用条款的约束。TI 提供这些资源并不会扩展或以其他方式更改 TI 针对 TI 产品发布的适用的担保或担保免责声明。

TI 反对并拒绝您可能提出的任何其他或不同的条款。

邮寄地址：Texas Instruments, Post Office Box 655303, Dallas, Texas 75265

Copyright © 2022，德州仪器 (TI) 公司