

采用 SOT-23 封装的 TLV61048 15V 输出电压非同步升压转换器

1 特性

- 输入电压：2.61V 至 5.5V（下降 2.4V）
- 输出电压最高 15V
- 集成低侧 FET：输入电压为 3.3V 时，电阻为 85mΩ
- 4.7A（典型值）开关电流限制
- 600kHz 或 1MHz 可选开关频率
- 1μA 关断电流
- 输出电压精度为 2.5%
- 轻负载下采用 PFM 运行模式
- 内部 2ms 软启动时间
- 热关断保护
- 6 引脚 3mm × 3mm SOT-23 封装

2 应用

- PLC 备用电源
- LCD 偏置电源
- 直流/直流工业隔离

3 说明

TLV61048 是一款非同步升压转换器，为由低电压超级电容器和单芯锂离子电池供电的产品提供电源解决方案。TLV61048 将电源开关与 4.7A 典型电流限制相集成，在不影响最大负载交付的情况下增强了输入电源的放电能力。TLV61048 也支持使用尺寸更小的宽范围外部电感器和输出电容器来简化设计工作。

通过配置 FREQ 引脚，TLV61048 的可选开关频率为 600kHz 或 1MHz。在轻负载时，该器件会进入 PFM 运行模式来实现更高的效率。TLV61048 具有 2ms 内置软启动时间，从而可最大程度地降低浪涌电流。

TLV61048 采用 3mm × 3mm 6 引脚 SOT-23 封装。

器件信息⁽¹⁾

器件型号	封装	封装尺寸（标称值）
TLV61048	SOT-23 (6)	2.90mm × 1.60mm

(1) 如需了解所有可用封装，请参阅数据表末尾的可订购产品附录。

简化原理图

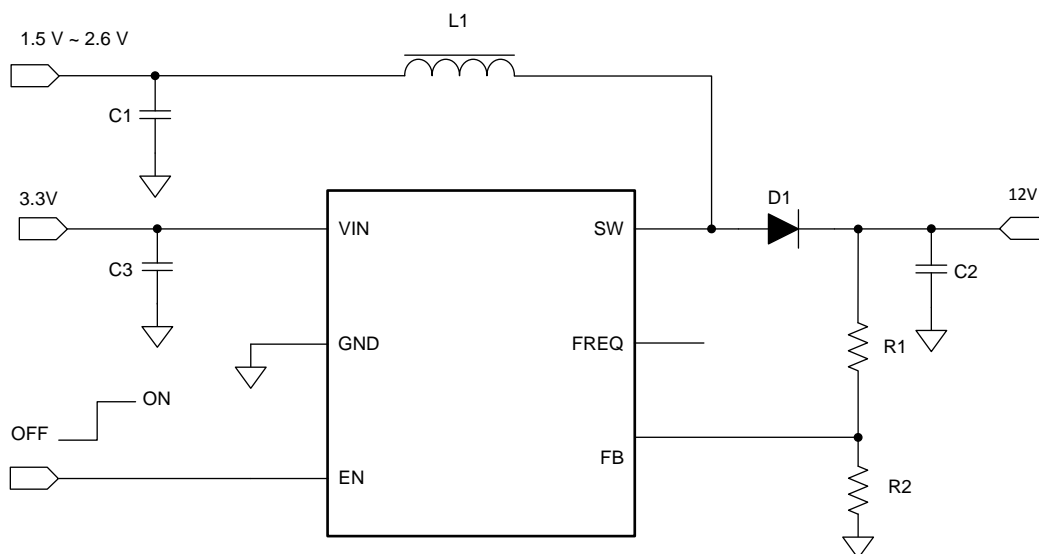

目录

1	特性	1	8	Application and Implementation	9
2	应用	1	8.1	Application Information.....	9
3	说明	1	8.2	Typical Applications	9
4	修订历史记录	2	9	Power Supply Recommendations	14
5	Pin Configuration and Functions	3	10	Layout.....	14
6	Specifications.....	4	10.1	Layout Guidelines	14
6.1	Absolute Maximum Ratings	4	10.2	Layout Example	14
6.2	ESD Ratings	4	11	器件和文档支持	15
6.3	Recommended Operating Conditions.....	4	11.1	器件支持	15
6.4	Thermal Information	4	11.2	接收文档更新通知	15
6.5	Electrical Characteristics.....	5	11.3	社区资源.....	15
7	Detailed Description	6	11.4	商标.....	15
7.1	Overview	6	11.5	静电放电警告.....	15
7.2	Functional Block Diagram	6	11.6	术语表	15
7.3	Feature Description.....	6	12	机械、封装和可订购信息.....	15
7.4	Device Functional Modes.....	7			

4 修订历史记录

注：之前版本的页码可能与当前版本有所不同。

日期	修订版本	说明
2019 年 3 月	*	初始发行版

5 Pin Configuration and Functions

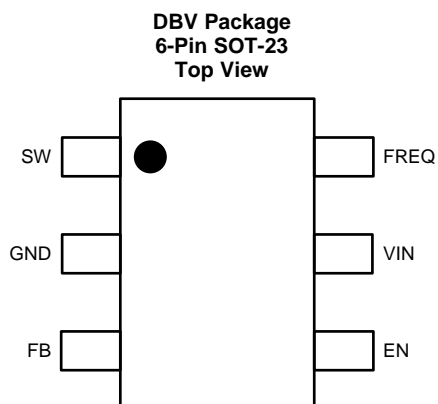

Pin Functions

PIN		I/O	DESCRIPTION
NO.	NAME		
1	SW	PWR	The switch pin of the converter. It is connected to the drain of the internal power MOSFET.
2	GND	PWR	Ground
3	FB	I	Voltage feedback of adjustable output voltage. Connected to the center tap of a resistor divider to program the output voltage.
4	EN	I	Enable logic input. Logic high voltage enables the device. Logic low voltage disables the device and turns it into shutdown mode.
5	VIN	I	IC power supply input
6	FREQ	I	Frequency select pin. The device operates at 600 kHz if FREQ is left floating and at 1 MHz if connected to GND.

6 Specifications

6.1 Absolute Maximum Ratings

over operating free-air temperature range (unless otherwise noted) ⁽¹⁾

		MIN	MAX	UNIT
Voltage range at terminals ⁽²⁾	VIN, EN, FREQ	-0.3	6	V
	SW	-0.3	18	V
	FB	-0.3	3.6	V
Operating junction temperature range, T _J		-40	150	°C

- (1) Stresses beyond those listed under *Absolute Maximum Ratings* may cause permanent damage to the device. These are stress ratings only, which do not imply functional operation of the device at these or any other conditions beyond those indicated under *Recommended Operating Conditions*. Exposure to absolute-maximum-rated conditions for extended periods may affect device reliability.
- (2) All voltage values are with respect to network ground terminal.

6.2 ESD Ratings

			VALUE	UNIT
V _(ESD) ⁽¹⁾	Electrostatic discharge	Human body model (HBM), per ANSI/ESDA/JEDEC JS-001, all pins ⁽²⁾	±2000	V
		Charged device model (CDM), per JEDEC specification JESD22-C101, all pins ⁽³⁾	±500	V

- (1) Electrostatic discharge (ESD) to measure device sensitivity and immunity to damage caused by assembly line electrostatic discharges in to the device.
- (2) JEDEC document JEP155 states that 500-V HBM allows safe manufacturing with a standard ESD control process.
- (3) JEDEC document JEP157 states that 250-V CDM allows safe manufacturing with a standard ESD control process.

6.3 Recommended Operating Conditions

over operating free-air temperature range (unless otherwise noted)

		MIN	TYP	MAX	UNIT
V _{IN}	Input voltage range	2.6		5.5	V
V _{OUT}	Output voltage range	3.3		14	V
L	Effective inductance range	2.2	4.7	10	μH
C _{IN}	Effective input capacitance range	0.22	1		μF
C _{OUT}	Effective output capacitance range	4.7			μF
T _J	Operating junction temperature	-40		125	°C

6.4 Thermal Information

THERMAL METRIC ⁽¹⁾		TLV61048	UNIT
		DBV (SOT23)	
		6 PINS	
R _{θJA}	Junction-to-ambient thermal resistance	177.7	°C/W
R _{θJC(top)}	Junction-to-case (top) thermal resistance	120.6	
R _{θJB}	Junction-to-board thermal resistance	33.2	
ψ _{JT}	Junction-to-top characterization parameter	21.5	
ψ _{JB}	Junction-to-board characterization parameter	32.6	
R _{θJC(bot)}	Junction-to-case (bottom) thermal resistance	n/a	

- (1) For more information about traditional and new thermal metrics, see the *IC Package Thermal Metrics* application report, [SPRA953](#).

6.5 Electrical Characteristics

$T_A = -40^{\circ}\text{C}$ to 85°C , $V_{IN} = 3.3\text{ V}$. Typical values are at $T_A = 25^{\circ}\text{C}$, unless otherwise noted.

PARAMETER		TEST CONDITIONS	MIN	TYP	MAX	UNIT
POWER SUPPLY						
V_{IN}	Input voltage range		2.6		5.5	V
V_{IN_UVLO}	Under voltage lockout threshold	V_{IN} rising		2.55	2.61	V
		V_{IN} falling	2.3	2.4		
V_{IN_HYS}	VIN UVLO hysteresis			150		mV
I_{Q_VIN}	Quiescent current into VIN pin	IC enabled, no load, no switching		100		μA
I_{SD}	Shutdown current into VIN pin	IC disabled, $V_{IN} = 2.6\text{ V}$ to 5.5 V , $T_A = 25^{\circ}\text{C}$			1.0	μA
OUTPUT						
V_{OUT}	Output voltage range		3.3		15	V
V_{REF}	Feedback voltage	PWM mode, $T_J = -40^{\circ}\text{C}$ to 125°C	0.78	0.8	0.82	V
		PFM mode, $T_A = 25^{\circ}\text{C}$		0.81		V
I_{FB_LKG}	Leakage current into FB pin	$T_A = 25^{\circ}\text{C}$			50	nA
I_{SW_LKG}	Leakage current into SW pin	IC disabled, $SW = 5.5\text{V}$			500	nA
POWER SWITCH						
$R_{DS(on)}$	Low-side MOSFET on resistance	$V_{in} = 3.3, V_{out} = 12\text{V}$		85		m Ω
f_{SW}	Switching frequency	Default, $SW = 1.5\text{V}$	480	550	620	kHz
		Default, $SW = 2.6\text{V}$	1020	1150	1280	
t_{OFF_min}	Min. off time	600kHz, $SW = 1.5\text{V}$		130		ns
I_{LIM_SW}	Peak switch current limit	600kHz, $V_{IN} = 3.3\text{V}$	3.8	4.7	5.6	A
$t_{STARTUP}$	Startup time			2		ms
LOGIC INTERFACE						
V_{EN_H}	EN Logic high threshold				1.2	V
V_{EN_L}	EN Logic low threshold		0.4			V
R_{EN}	EN Pull Down Resistor			1		M Ω
R_{FREQ}	FREQ pull up resistance			800		k Ω
V_{FREQ_H}	FREQ logic high threshold				1.2	V
V_{FREQ_L}	FREQ logic low threshold		0.4			V
PROTECTION						
T_{SD}	Thermal shutdown threshold	T_J rising		150		$^{\circ}\text{C}$
T_{SD_HYS}	Thermal shutdown hysteresis	T_J falling below T_{SD}		20		$^{\circ}\text{C}$

7 Detailed Description

7.1 Overview

The TLV61048 is a non-synchronous boost converter supporting output voltage up to 15 V with input ranging from 2.61 V to 5.5 V. The TLV61048 integrates a power switch with current limit up to 4.7 A (typical). The device operates in a current mode scheme with quasi-constant frequency with internal loop compensation built in. The switching frequency is selectable between 600 kHz and 1 MHz. There is internal fixed soft start time which is 2 ms typically to control the inrush current during startup.

Topology of the TLV61048 boost converter is adaptive off-time with peak current control, which provides superior load and line transient responses. The selectable switching frequency offers the possibility to optimize the design either for the use of small sized inductor (1 MHz) or for higher system efficiency (600 kHz).

The converter operates in continuous conduction mode (CCM) when the inductor valley current is above zero, while switches into discontinuous conduction mode (DCM) if valley current crossing zero. If the load is further lowered, the device enters into PFM operation to achieve even higher efficiency.

7.2 Functional Block Diagram

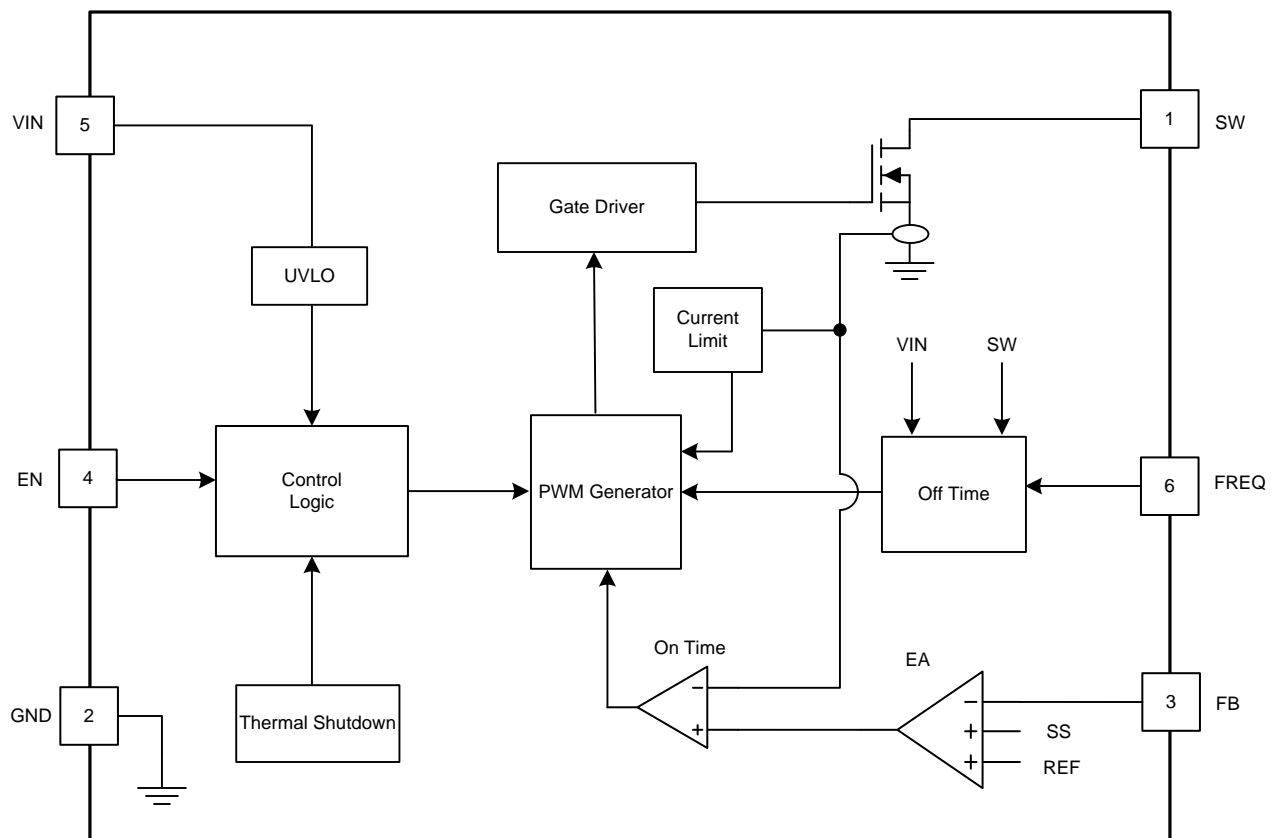

7.3 Feature Description

7.3.1 Undervoltage Lockout

An undervoltage lockout (UVLO) circuit stops the operation of the converter when the input voltage drops below the typical UVLO threshold of 2.4 V. A hysteresis of 150 mV is added so that the device cannot be enabled again until the input voltage goes up to 2.55 V. This function is implemented in order to prevent malfunctioning of the device when the input voltage is between 2.4 V and 2.55 V.

Feature Description (接下页)

7.3.2 Enable and Disable

When the input voltage is above typical UVLO rising threshold of 2.55 V and the EN pin is pulled high, the TLV61048 is enabled. When the EN pin is pulled low, the TLV61048 stops the PWM switch and turns off the low side switch. The EN pin has an internal pull-down resistance of 1M Ω , the device is disabled when the EN pin is floating. In shutdown mode, less than 1- μ A input current is consumed.

7.3.3 Soft Start

The soft-start feature helps the regulator to gradually reach the steady state operating point, thus reducing start-up stresses and surge. When the input voltage is applied, the output capacitor is charged to VIN through the inductor and high side rectifier diode. After reaching the 2.55 V (typical) UVLO threshold, the internal soft-start control circuit initiates to ramp the reference voltage to 0.8 V within 2 ms (typical), while the low side FET starts switching after output capacitor is charged to the input voltage.

7.3.4 Frequency Select (FREQ)

The frequency select pin FREQ allows to set the switching frequency of the device to 600 kHz (FREQ = floating) or 1 MHz (FREQ = GND). Higher switching frequency improves load transient response but reduces efficiency slightly. The other benefit of higher switching frequency is lower output ripple voltage.

7.4 Device Functional Modes

The TLV61048 has two operation modes: PWM mode and PFM mode.

7.4.1 PWM Mode

The TLV61048 uses a quasi-constant frequency pulse width modulation (PWM) at moderate to heavy load currents. Based on the VIN/VOU ratio, a circuit predicts the required off-time. At the beginning of the switching cycle, the integrated NMOS switching FET, shown in the functional block diagram, is turned on. The input voltage is applied across the inductor and the inductor current ramps up. In this phase, the output capacitor is discharged by the load current. When the inductor current hits the current threshold that is set by the error amplifier output, the PWM switch is turned off, and the external power diode is forward-biased. The inductor transfers its stored energy to replenish the output capacitor and supply the load. When the off-time is expired, the next switching cycle starts again. The error amplifier compares the FB pin voltage with an internal reference, and its output determines the duty cycle of the PWM switching.

The TLV61048 has a built-in compensation circuit that can accommodate a wide range of input and output voltages for stable operation.

7.4.2 PFM Mode

The TLV61048 integrates a power save mode with pulse frequency modulation (PFM) to improve efficiency at light load. When the load current decreases, the inductor peak current set by the output of the error amplifier declines to regulate the output voltage. When the inductor peak current hits the low limit (400 mA typical), the output voltage exceeds the set threshold voltage as the load current decreases further. When the FB voltage hits the PFM reference voltage, the TLV61048 goes into power-save mode. In the power-save mode, the device only switches when the output voltage trips below a set threshold voltage. It ramps up the output with several pulses and enters the power save mode when the output voltage exceeds the set threshold voltage.

Device Functional Modes (接下页)

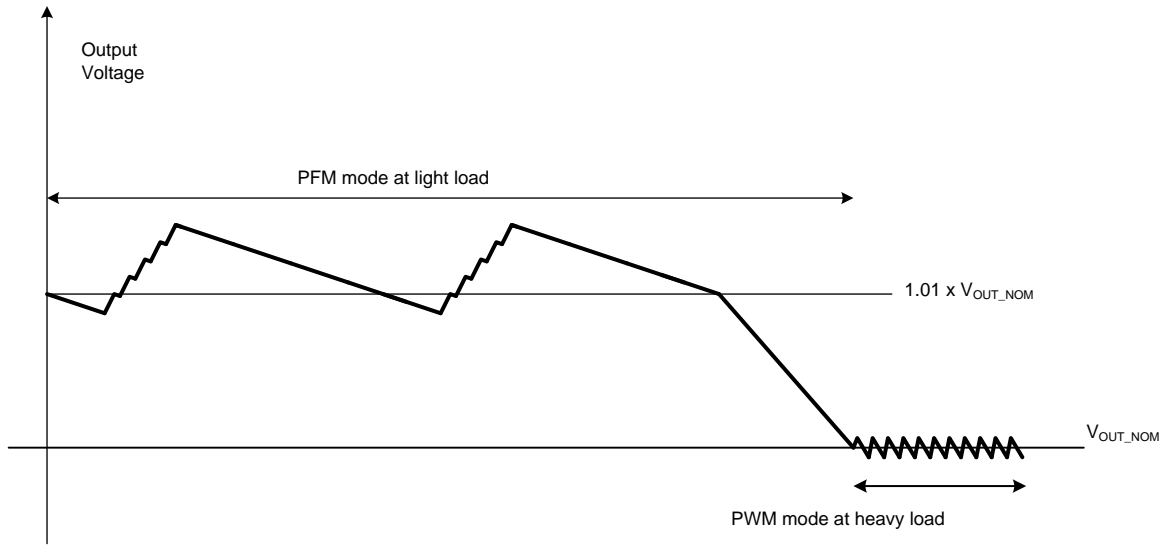

ADVANCE INFORMATION

8 Application and Implementation

注

Information in the following applications sections is not part of the TI component specification, and TI does not warrant its accuracy or completeness. TI's customers are responsible for determining suitability of components for their purposes. Customers should validate and test their design implementation to confirm system functionality.

8.1 Application Information

TLV61048 is a boost DC/DC converter integrating a power switch and loop compensation circuits. The device supports up to 15-V output with the input range from 2.61 V to 5.5 V. The device can operate down to 1.5 V if an external 3.3-V bias supply is applied to the VIN pin. The TLV61048 adopts the current-mode control with adaptive constant off-time. The switching frequency is quasi-constant and selectable between 600 kHz and 1 MHz. The following design procedure can be used to select component values for the TLV61048.

8.2 Typical Applications

8.2.1 12-V Output Boost Converter With External Bias

In this design example, TLV61048 VIN pin is supplied by an external 3.3-V bias voltage to keep internal circuitry on in order to extend power stage operating V_{IN} to 1.5 V. 600-kHz switching frequency is selected to reduce switching loss in order to improve overall efficiency.



图 1. 12-V Boost Converter With External Bias

8.2.1.1 Design Requirements

For this design example, see parameters are shown in 表 1:

表 1. Design Requirements

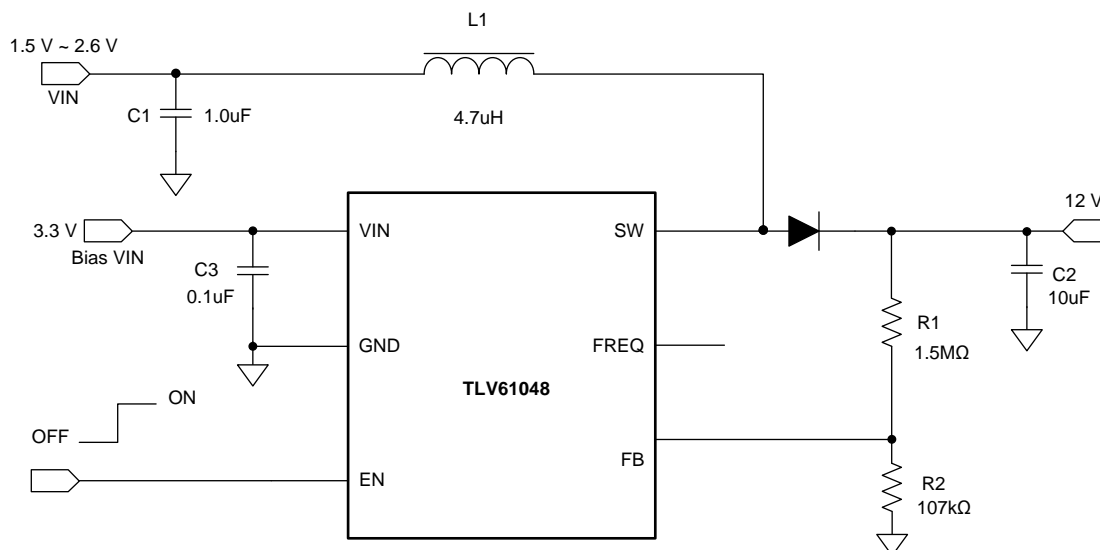
PARAMETERS	VALUE
Power input voltage	1.5 V to 2.7 V
Control input voltage	3.3 V
Output voltage	12 V
Frequency	600 kHz
Output current	0 - 100 mA

8.2.1.2 Detailed Design Procedure

8.2.1.2.1 Programming the Output Voltage

Output voltage is programmed via external resistor divider. By selecting the external resistor divider R1 and R2, as shown in [公式 1](#), the output voltage is programmed to the desired value. When the output voltage is regulated, the typical voltage at the FB pin is V_{REF} of 800 mV.

$$R1 = \left(\frac{V_{OUT}}{V_{REF}} - 1 \right) \times R2$$

where

- V_{OUT} is the desired output voltage
 - V_{REF} is the internal reference voltage at the FB pin
- (1)

For best accuracy, R2 should be kept smaller than 150 k Ω to ensure the current flowing through R2 is at least 100 times larger than the FB pin leakage current. Changing R2 towards a lower value increases the immunity against noise injection. Changing the R2 towards a higher value reduces the quiescent current for achieving higher efficiency at low load currents.

8.2.1.2.2 Inductor Selection

Because the selection of the inductor affects steady state operation, transient behavior, and loop stability, the inductor is the most important component in power regulator design. There are three important inductor specifications, inductor value, saturation current, and DC resistance (DCR). The TLV61048 is designed to work with inductor values between 2.2 μ H and 10 μ H. Use [公式 2](#) to [公式 4](#) to calculate the peak current of the application inductor. To calculate the current in the worst case, use the minimum input voltage, maximum output voltage, and maximum load current of the application. To have enough design margin, choose the inductor value with -30% tolerance, and a low power-conversion efficiency for the calculation. In a boost regulator, the inductor dc current can be calculated with [公式 2](#).

$$I_{L(DC)} = \frac{V_{OUT} \times I_{OUT}}{V_{IN} \times \eta}$$

where

- V_{OUT} = output voltage
 - I_{OUT} = output current
 - V_{IN} = input voltage
 - η = power conversion efficiency, use 80% for most applications
- (2)

The inductor ripple current is calculated with the [公式 3](#) for an asynchronous boost converter in continuous conduction mode (CCM).

$$\Delta I_{L(P-P)} = \frac{V_{IN} \times (V_{OUT} + 0.8V - V_{IN})}{L \times f_{SW} \times (V_{OUT} + 0.8V)}$$

where

- $\Delta I_{L(P-P)}$ = inductor ripple current
 - L = inductor value
 - f_{SW} = switching frequency
 - V_{OUT} = output voltage
 - V_{IN} = input voltage
- (3)

Therefore, the inductor peak current is calculated with [公式 4](#).

$$I_{L(P)} = I_{L(DC)} + \frac{\Delta I_{L(P-P)}}{2}$$
(4)

Normally, it is advisable to work with an inductor peak-to-peak current of less than 40% of the average inductor current for maximum output current. A smaller ripple from a larger valued inductor reduces the magnetic hysteresis losses in the inductor and EMI. However, in the same way, load transient response time is increased. [表 2](#) lists the recommended inductor for the TLV61048 in the 600-kHz configuration.

表 2. Recommended Inductors for the TLV61048 at 600-kHz Configuration

PART NUMBER	L (μH)	DCR MAX (mΩ)	SATURATION CURRENT TYPICAL (A)	SIZE (L×W×H) (mm)	VENDOR ⁽¹⁾
SWPA5040S4R7NT	4.7	39	3.9	5 × 5 × 4	Sunlord
XAL4030-472ME	4.7	44.1	4.5	4 × 4 × 3	Coilcraft
SWPA5040S100MT	10	83	2.9	5 × 5 × 4	Sunlord
XAL4040-103ME	10	92.4	3	4 × 4 × 4	Coilcraft

(1) See [Third-party Products Disclaimer](#)

8.2.1.2.3 Input and Output Capacitor Selection

The output capacitor is mainly selected to meet the requirements for output ripple and loop stability. This ripple voltage is related to the capacitor's capacitance and its equivalent series resistance (ESR). Assuming a ceramic capacitor with zero ESR, the minimum capacitance needed for a given ripple can be calculated by:

$$C_{OUT} = \frac{I_{OUT} \times D_{MAX}}{f_{SW} \times V_{RIPPLE}}$$

where

- D_{MAX} = maximum switching duty cycle
- V_{RIPPLE} = peak to peak output voltage ripple (5)

The ESR impact on the output ripple must be considered if tantalum or aluminum electrolytic capacitors are used.

Take care when evaluating the derating of a ceramic capacitor under DC bias, aging, and AC signal. For example, the DC bias can significantly reduce capacitance. A ceramic capacitor can lose more than 50% of its capacitance at its rated voltage. Therefore, always leave margin on the voltage rating to ensure adequate capacitance at the required output voltage.

TI recommends using the output capacitor with effective capacitance in the range of 4.7 μF to 10 μF for 600-kHz configuration. TI also recommends placing a small 1 μF capacitor right across the rectifier diode cathode to the GND pin of the TLV61048 to reduce the high RMS current loop's inductance. The output capacitor affects the small signal control loop stability of the boost regulator. If the output capacitor is below the range, the boost regulator can potentially become unstable. Increasing the output capacitor makes the output voltage ripple smaller in PWM mode. [表 3](#) lists the recommended capacitor for the TLV61048.

表 3. Recommended Output Capacitors for the TLV61048

PART NUMBER	C _{OUT} (μF)	RATING	PACKAGE	VENDOR ⁽¹⁾
TMK316BLD106KL	10	25 V, X5R	1206	Taiyo Yuden
CC1206KKX5R8BB106	10	25 V, X5R	1206	Yageo

(1) See [Third-party Products Disclaimer](#).

For input capacitor, a ceramic capacitor with more than 1 μF is enough for most applications.

8.2.1.3 Application Curves

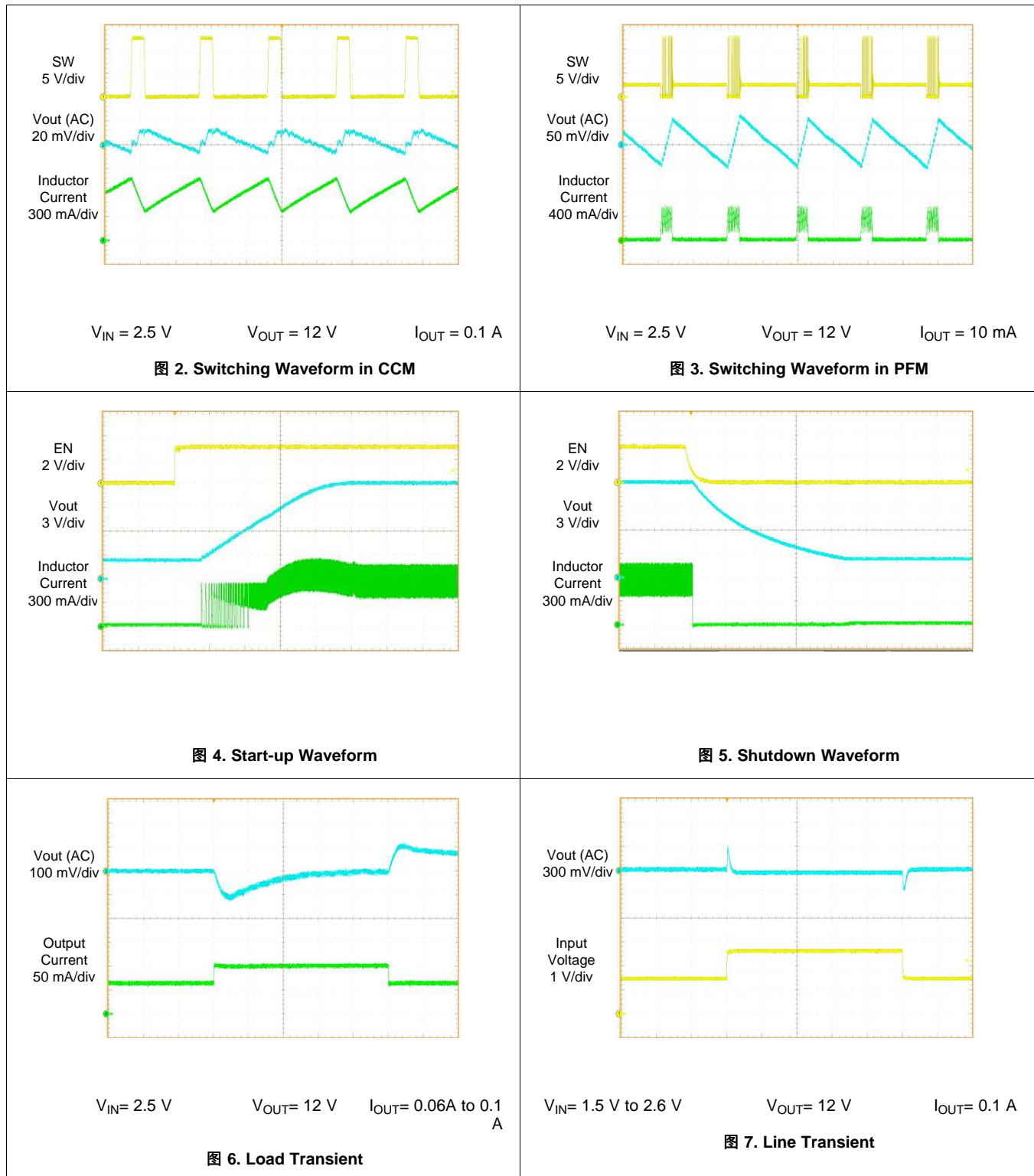

8.2.2 15-V Output Boost Converter

In this design example, TLV61048 is configured to output 15-V DC voltage. 1-MHz switching frequency is selected to reduce output ripple and improve load transient performance. TI recommends placing an RC snubber from the switch node to the ground node to ensure voltage spike does not exceed the specified absolute maximum rating.



图 8. 15-V Boost Converter

8.2.2.1 Design Requirements

表 4. Design Requirements

PARAMETER	VALUE
Power input voltage	2.6 V to 5.5 V
Output voltage	15 V
Frequency	1 MHz
Output current	0 to 300 mA

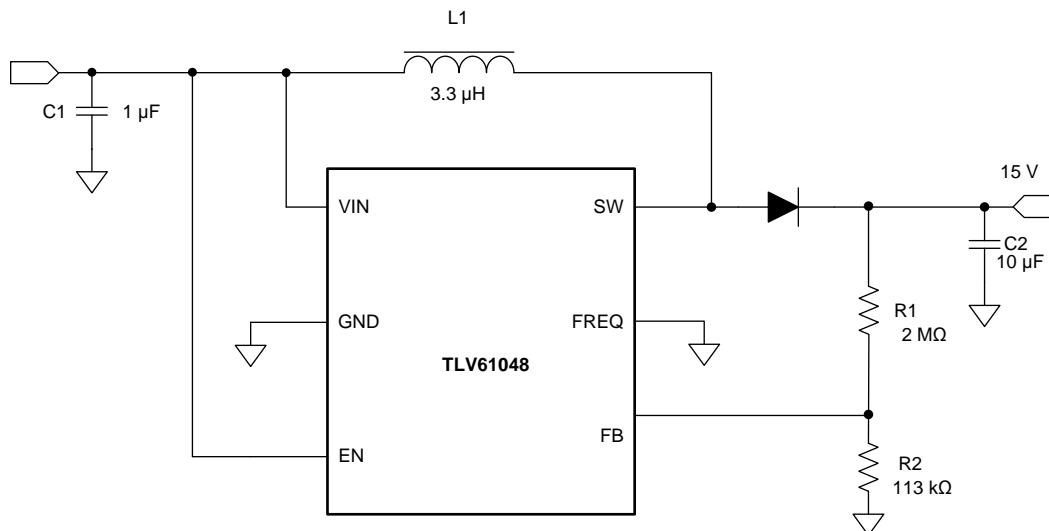
8.2.2.2 Detailed Design Procedure

8.2.2.2.1 Inductor Selection

Load transient and loop response performance is optimized at 1-MHz configuration, a smaller inductance is selected to push the right-half-plane-zero to a higher frequency beyond the crossover frequency of the control loop. The recommended inductors for 1-MHz operation are listed in 表 5.

表 5. Recommended Inductors for the TLV61048 at 1-MHz Configuration

PART NUMBER	L (μH)	DCR MAX (mΩ)	SATURATION CURRENT TYPICAL (A)	SIZE (LxWxH) (mm)	VENDOR ⁽¹⁾
SWPA5040S2R2NT	2.2	25	5.6	5 × 5 × 4	Sunlord
XAL4020-222ME	2.2	38.7	5.6	4 × 4 × 3	Coilcraft
SWPA5040S3R3NT	3.3	31	4.6	5 × 5 × 4	Sunlord
XAL4030-332ME	3.3	28.6	5.5	4 × 4 × 4	Coilcraft

(1) See [Third-party Products Disclaimer](#).

8.2.2.2.2 Input and Output Capacitor Selection

For 1-MHz configuration, use the information provided in [Input and Output Capacitor Selection](#).

9 Power Supply Recommendations

The device is designed to operate from an input voltage supply range between 1.5 V to 5.5 V. This input supply must be well regulated. If the input supply is located more than a few inches from the converter, additional bulk capacitance may be required in addition to the ceramic bypass capacitors. A typical choice is an electrolytic or tantalum capacitor with a value of 47 μ F. Output current of the input power supply must be rated according to the supply voltage, output voltage and output current of the TLV61048.

10 Layout

10.1 Layout Guidelines

As for all switching power supplies, especially those running at high switching frequency and high currents, layout is an important design step. If the layout is not carefully done, the regulator could suffer from instability and noise problems. To maximize efficiency, switch rise and fall time are very fast. To prevent radiation of high frequency noise (for example, EMI), proper layout of the high-frequency switching path is essential. Minimize the length and area of all traces connected to the SW pin, and always use a ground plane under the switching regulator to minimize interplane coupling. The input capacitor must not only be close to the VIN pin, but also to the GND in order to reduce input supply ripple.

The most critical current path for all boost converters is from the switching FET, through the rectifier diode, then the output capacitors, and back to ground of the switching FET. This high current path contains nanosecond rise and fall time and must be kept as short as possible. Therefore, the output capacitor must not only be close to the VOUT pin, but also to the GND pin to reduce the overshoot at the SW pin and VOUT pin.

10.2 Layout Example



图 9. TLV61048 Layout

11 器件和文档支持

11.1 器件支持

11.1.1 第三方产品免责声明

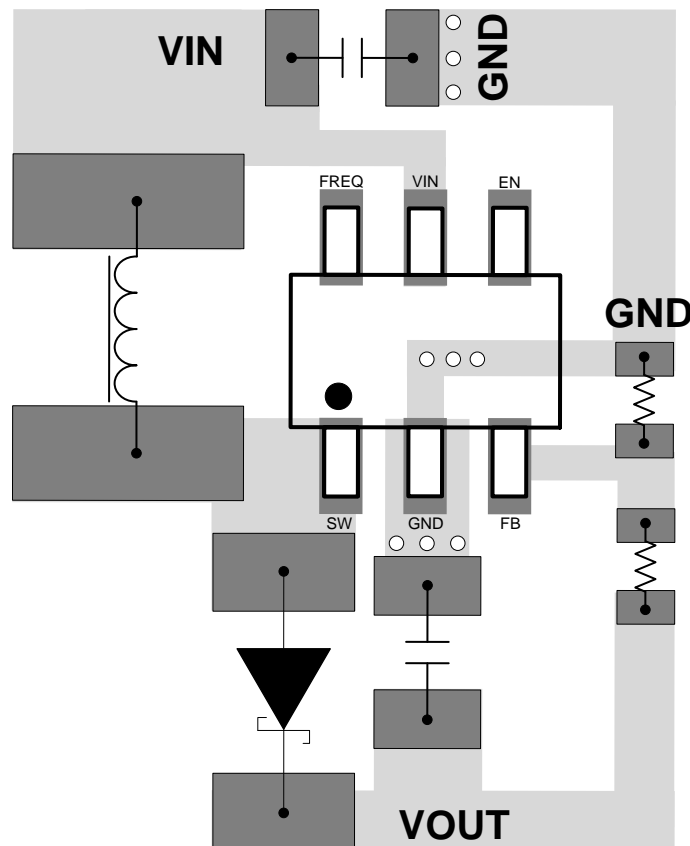
TI 发布的与第三方产品或服务有关的信息，不能构成与此类产品或服务或保修的适用性有关的认可，不能构成此类产品或服务单独或与任何 TI 产品或服务一起的表示或认可。

11.2 接收文档更新通知

要接收文档更新通知，请导航至 TI.com.cn 上的器件产品文件夹。单击右上角的 *通知我* 进行注册，即可每周接收产品信息更改摘要。有关更改的详细信息，请查看任何已修订文档中包含的修订历史记录。

11.3 社区资源

下列链接提供到 TI 社区资源的连接。链接的内容由各个分销商“按照原样”提供。这些内容并不构成 TI 技术规范，并且不一定反映 TI 的观点；请参阅 TI 的 [《使用条款》](#)。

TI E2E™ Online Community *TI's Engineer-to-Engineer (E2E) Community*. Created to foster collaboration among engineers. At e2e.ti.com, you can ask questions, share knowledge, explore ideas and help solve problems with fellow engineers.

Design Support *TI's Design Support* Quickly find helpful E2E forums along with design support tools and contact information for technical support.

11.4 商标

E2E is a trademark of Texas Instruments.
All other trademarks are the property of their respective owners.

11.5 静电放电警告



ESD 可能会损坏该集成电路。德州仪器 (TI) 建议通过适当的预防措施处理所有集成电路。如果不遵守正确的处理措施和安装程序，可能会损坏集成电路。

ESD 的损坏小至导致微小的性能降级，大至整个器件故障。精密的集成电路可能更容易受到损坏，这是因为非常细微的参数更改都可能会导致器件与其发布的规格不相符。

11.6 术语表

SLYZ022 — TI 术语表。

这份术语表列出并解释术语、缩写和定义。

12 机械、封装和可订购信息

以下页面包含机械、封装和可订购信息。这些信息是指定器件的最新可用数据。数据如有变更，恕不另行通知，且不会对此文档进行修订。如需获取此产品说明书的浏览器版本，请查阅左侧的导航栏。

PACKAGING INFORMATION

Orderable Device	Status (1)	Package Type	Package Drawing	Pins	Package Qty	Eco Plan (2)	Lead finish/ Ball material (6)	MSL Peak Temp (3)	Op Temp (°C)	Device Marking (4/5)	Samples
TLV61048DBVR	ACTIVE	SOT-23	DBV	6	3000	RoHS & Green	NIPDAU	Level-1-260C-UNLIM	-40 to 125	1VSF	Samples
TLV61048DBVT	ACTIVE	SOT-23	DBV	6	250	RoHS & Green	NIPDAU	Level-1-260C-UNLIM	-40 to 125	1VSF	Samples

(1) The marketing status values are defined as follows:

ACTIVE: Product device recommended for new designs.

LIFEBUY: TI has announced that the device will be discontinued, and a lifetime-buy period is in effect.

NRND: Not recommended for new designs. Device is in production to support existing customers, but TI does not recommend using this part in a new design.

PREVIEW: Device has been announced but is not in production. Samples may or may not be available.

OBSOLETE: TI has discontinued the production of the device.

(2) **RoHS:** TI defines "RoHS" to mean semiconductor products that are compliant with the current EU RoHS requirements for all 10 RoHS substances, including the requirement that RoHS substance do not exceed 0.1% by weight in homogeneous materials. Where designed to be soldered at high temperatures, "RoHS" products are suitable for use in specified lead-free processes. TI may reference these types of products as "Pb-Free".

RoHS Exempt: TI defines "RoHS Exempt" to mean products that contain lead but are compliant with EU RoHS pursuant to a specific EU RoHS exemption.

Green: TI defines "Green" to mean the content of Chlorine (Cl) and Bromine (Br) based flame retardants meet JS709B low halogen requirements of <=1000ppm threshold. Antimony trioxide based flame retardants must also meet the <=1000ppm threshold requirement.

(3) MSL, Peak Temp. - The Moisture Sensitivity Level rating according to the JEDEC industry standard classifications, and peak solder temperature.

(4) There may be additional marking, which relates to the logo, the lot trace code information, or the environmental category on the device.

(5) Multiple Device Markings will be inside parentheses. Only one Device Marking contained in parentheses and separated by a "~" will appear on a device. If a line is indented then it is a continuation of the previous line and the two combined represent the entire Device Marking for that device.

(6) Lead finish/Ball material - Orderable Devices may have multiple material finish options. Finish options are separated by a vertical ruled line. Lead finish/Ball material values may wrap to two lines if the finish value exceeds the maximum column width.

Important Information and Disclaimer:The information provided on this page represents TI's knowledge and belief as of the date that it is provided. TI bases its knowledge and belief on information provided by third parties, and makes no representation or warranty as to the accuracy of such information. Efforts are underway to better integrate information from third parties. TI has taken and continues to take reasonable steps to provide representative and accurate information but may not have conducted destructive testing or chemical analysis on incoming materials and chemicals. TI and TI suppliers consider certain information to be proprietary, and thus CAS numbers and other limited information may not be available for release.

In no event shall TI's liability arising out of such information exceed the total purchase price of the TI part(s) at issue in this document sold by TI to Customer on an annual basis.

EXAMPLE STENCIL DESIGN

DBV0006A

SOT-23 - 1.45 mm max height

SMALL OUTLINE TRANSISTOR

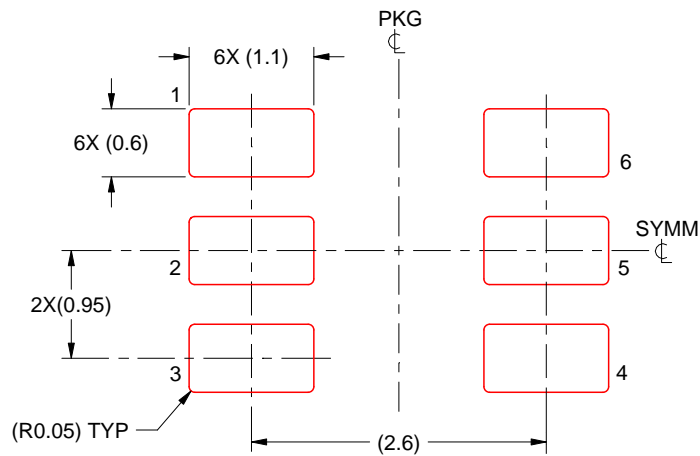

SOLDER PASTE EXAMPLE
BASED ON 0.125 mm THICK STENCIL
SCALE:15X

4214840/C 06/2021

NOTES: (continued)

8. Laser cutting apertures with trapezoidal walls and rounded corners may offer better paste release. IPC-7525 may have alternate design recommendations.
9. Board assembly site may have different recommendations for stencil design.

重要声明和免责声明

TI 提供技术和可靠性数据（包括数据表）、设计资源（包括参考设计）、应用或其他设计建议、网络工具、安全信息和其他资源，不保证没有瑕疵且不做任何明示或暗示的担保，包括但不限于对适销性、某特定用途方面的适用性或不侵犯任何第三方知识产权的暗示担保。

这些资源可供使用 TI 产品进行设计的熟练开发人员使用。您将自行承担以下全部责任：(1) 针对您的应用选择合适的 TI 产品，(2) 设计、验证并测试您的应用，(3) 确保您的应用满足相应标准以及任何其他安全、安保或其他要求。这些资源如有变更，恕不另行通知。TI 授权您仅可将这些资源用于研发本资源所述的 TI 产品的应用。严禁对这些资源进行其他复制或展示。您无权使用任何其他 TI 知识产权或任何第三方知识产权。您应全额赔偿因在这些资源的使用中对 TI 及其代表造成的任何索赔、损害、成本、损失和债务，TI 对此概不负责。

TI 提供的产品受 TI 的销售条款 (<https://www.ti.com.cn/zh-cn/legal/termsofsale.html>) 或 [ti.com.cn](https://www.ti.com.cn) 上其他适用条款/TI 产品随附的其他适用条款的约束。TI 提供这些资源并不会扩展或以其他方式更改 TI 针对 TI 产品发布的适用的担保或担保免责声明。

邮寄地址：上海市浦东新区世纪大道 1568 号中建大厦 32 楼，邮政编码：200122

Copyright © 2021 德州仪器半导体技术（上海）有限公司