

## ISO7810 高性能 8000 V<sub>PK</sub> 增强型单通道数字隔离器

### 1 特性

- 信号传输速率：高达 100Mbps
- 宽电源电压范围：2.25V 至 5.5V
- 2.25V 至 5.5V 电平转换
- 宽温度范围：-55°C 至 125°C
- 低功耗，每通道电流典型值为 1.8mA（1Mbps 时）
- 低传播延迟：典型值 11ns（5V 电源供电时）
- 行业领先的 CMTI：±100kV/μs
- 优异的电磁兼容性 (EMC)
- 系统级静电放电 (ESD)、瞬态放电 (EFT) 以及抗浪涌保护
- 低辐射
- 隔离栅寿命：> 25 年
- 宽体 (DW) 小外形尺寸集成电路 (SOIC)-16 封装
- 安全及管理批准：
  - 8000 V<sub>PK</sub> V<sub>IOTM</sub> 和 2121 V<sub>PK</sub> V<sub>IORM</sub> 增强型隔离，符合 DIN V VDE V 0884-10 (VDE V 0884-10):2006-12 标准
  - 符合 UL 1577 标准且长达 1 分钟的 5.7kV<sub>RMS</sub> 隔离
  - CSA 组件接受通知 5A, IEC 60950-1、IEC 60601-1 和 IEC 61010-1 终端设备标准
  - 通过 GB4943.1-2011 CQC 认证

### 2 应用范围

- 工业自动化
- 电机控制
- 电源
- 太阳能逆变器
- 医疗设备
- 混合动力电动汽车

### 3 说明

7810ISO 是一款高性能单通道数字隔离器，隔离电压高达 8000 V<sub>PK</sub>。该器件已通过符合 VDE、CSA 和 CQC 标准的增强型隔离认证。在隔离 CMOS 或者 LVCMOS 数字 I/O 时，该隔离器可提供高电磁抗扰度和低辐射，且具有低功耗特性。每个隔离通道的逻辑输入和输出缓冲器均由二氧化硅 (SiO<sub>2</sub>) 绝缘栅栅分离开来。如果出现输入功率或信号丢失，ISO7810 器件默认输出“高”电平，ISO7810F 器件默认输出“低”电平。更多详细信息，请参见 [器件功能模式](#)。与隔离式电源一起使用时，此器件可防止数据总线或者其它电路上的噪音电流进入本地接地，以及干扰或损坏敏感电路。凭借创新的芯片设计和布线技术，ISO7810 的电磁兼容性得到了显著增强，从而可确保提供系统级 ESD、EFT 和浪涌保护并符合辐射标准。ISO7810 采用 16 引脚 SOIC 宽体 (DW) 封装。

#### 器件信息<sup>(1)</sup>

部件号	封装	封装尺寸 (标称值)
ISO7810 ISO7810F	SOIC, DW (16)	10.30mm x 7.50mm

(1) 要了解所有可用封装，请见数据表末尾的可订购产品附录。

#### 简化电路原理图

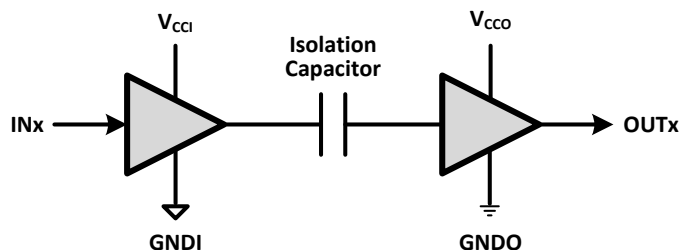

(1) V<sub>CCI</sub> 和 GNDI 分别是输入通道的电源和接地连接。

(2) V<sub>CCO</sub> 和 GNDO 分别是输出通道的电源和接地连接。



## 目录

<b>1</b>	特性 .....	<b>1</b>	<b>8.1</b>	Overview .....	<b>10</b>
<b>2</b>	应用范围 .....	<b>1</b>	<b>8.2</b>	Functional Block Diagram .....	<b>10</b>
<b>3</b>	说明 .....	<b>1</b>	<b>8.3</b>	Feature Description .....	<b>11</b>
<b>4</b>	修订历史记录 .....	<b>2</b>	<b>8.4</b>	Device Functional Modes .....	<b>15</b>
<b>5</b>	<b>Pin Configuration and Functions</b> .....	<b>3</b>	<b>9</b>	<b>Applications and Implementation</b> .....	<b>16</b>
<b>6</b>	<b>Specifications</b> .....	<b>4</b>	<b>9.1</b>	Application Information .....	<b>16</b>
<b>6.1</b>	Absolute Maximum Ratings .....	<b>4</b>	<b>9.2</b>	Typical Application .....	<b>16</b>
<b>6.2</b>	ESD Ratings .....	<b>4</b>	<b>10</b>	<b>Power Supply Recommendations</b> .....	<b>18</b>
<b>6.3</b>	Recommended Operating Conditions .....	<b>4</b>	<b>11</b>	<b>Layout</b> .....	<b>19</b>
<b>6.4</b>	Thermal Information .....	<b>5</b>	<b>11.1</b>	PCB Material .....	<b>19</b>
<b>6.5</b>	Power Rating .....	<b>5</b>	<b>11.2</b>	Layout Guidelines .....	<b>19</b>
<b>6.6</b>	Electrical Characteristics, 5 V .....	<b>5</b>	<b>11.3</b>	Layout Example .....	<b>19</b>
<b>6.7</b>	Electrical Characteristics, 3.3 V .....	<b>6</b>	<b>12</b>	<b>器件和文档支持</b> .....	<b>20</b>
<b>6.8</b>	Electrical Characteristics, 2.5 V .....	<b>6</b>	<b>12.1</b>	文档支持 .....	<b>20</b>
<b>6.9</b>	Switching Characteristics, 5 V .....	<b>7</b>	<b>12.2</b>	相关链接 .....	<b>20</b>
<b>6.10</b>	Switching Characteristics, 3.3 V .....	<b>7</b>	<b>12.3</b>	社区资源 .....	<b>20</b>
<b>6.11</b>	Switching Characteristics, 2.5 V .....	<b>7</b>	<b>12.4</b>	商标 .....	<b>20</b>
<b>6.12</b>	Typical Characteristics .....	<b>8</b>	<b>12.5</b>	静电放电警告 .....	<b>20</b>
<b>7</b>	<b>Parameter Measurement Information</b> .....	<b>9</b>	<b>12.6</b>	Glossary .....	<b>20</b>
<b>8</b>	<b>Detailed Description</b> .....	<b>10</b>	<b>13</b>	<b>机械、封装和可订购信息</b> .....	<b>20</b>

## 4 修订历史记录

### Changes from Original (July 2015) to Revision A

**Page**

•	已从“单页产品预览”更改为“量产”数据表 .....	<b>1</b>
---	----------------------------	----------

## 5 Pin Configuration and Functions

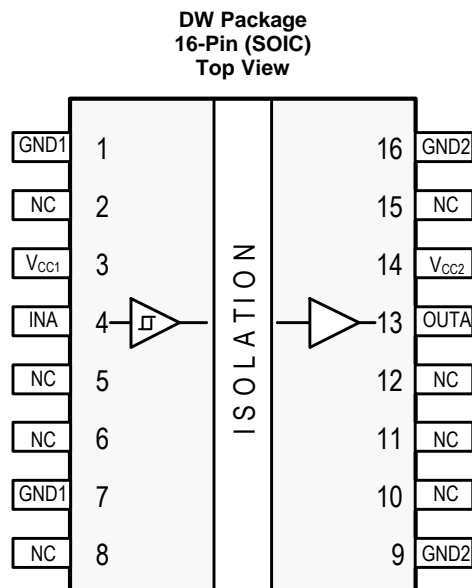

**Pin Functions**

PIN		I/O	DESCRIPTION
NAME	NO.		
GND1	1, 7	–	Ground connection for $V_{CC1}$
GND2	9, 16	–	Ground connection for $V_{CC2}$
INA	4	I	Input, channel A
NC	2, 5, 6, 8, 10, 11, 12, 15	–	Not connected
OUTA	13	O	Output, channel A
$V_{CC1}$	3	–	Power supply, $V_{CC1}$
$V_{CC2}$	14	–	Power supply, $V_{CC2}$

## 6 Specifications

### 6.1 Absolute Maximum Ratings<sup>(1)</sup>

		MIN	MAX	UNIT
Supply voltage <sup>(2)</sup>	$V_{CC1}, V_{CC2}$	-0.5	6	V
Voltage	INx, OUTx	-0.5	$V_{CC} + 0.5^{(3)}$	V
Output Current	$I_O$	-15	15	mA
Storage temperature, $T_{stg}$		-65	150	°C

- (1) Stresses beyond those listed under *absolute maximum ratings* may cause permanent damage to the device. These are stress ratings only and functional operation of the device at these or any other conditions beyond those indicated under *Recommended Operating Conditions* is not implied. Exposure to absolute-maximum-rated conditions for extended periods may affect device reliability.
- (2) All voltage values except differential I/O bus voltages are with respect to the local ground terminal (GND1 or GND2) and are peak voltage values.
- (3) Maximum voltage must not exceed 6 V.

### 6.2 ESD Ratings

		VALUE	UNIT	
$V_{ESD}$	Electrostatic discharge	Human body model (HBM), per ANSI/ESDA/JEDEC JS-001, all pins <sup>(1)</sup>	±6000	V
		Charged device model (CDM), per JEDEC specification JESD22-C101, all pins <sup>(2)</sup>	±1500	V

- (1) JEDEC document JEP155 states that 500-V HBM allows safe manufacturing with a standard ESD control process.
- (2) JEDEC document JEP157 states that 250-V CDM allows safe manufacturing with a standard ESD control process.

### 6.3 Recommended Operating Conditions

		MIN	TYP	MAX	UNIT
$V_{CC1}, V_{CC2}$	Supply voltage	2.25		5.5	V
$I_{OH}$	High-level output current	$V_{CCO}^{(1)} = 5\text{ V}$		-4	mA
		$V_{CCO} = 3.3\text{ V}$		-2	
		$V_{CCO} = 2.5\text{ V}$		-1	
$I_{OL}$	Low-level output current	$V_{CCO} = 5\text{ V}$		4	mA
		$V_{CCO} = 3.3\text{ V}$		2	
		$V_{CCO} = 2.5\text{ V}$		1	
$V_{IH}$	High-level input voltage	$0.7 \times V_{CCI}^{(1)}$		$V_{CCI}$	V
$V_{IL}$	Low-level input voltage	0		$0.3 \times V_{CCI}$	V
$t_{ui}$	Input pulse duration	7			ns
DR	Signaling rate	0		100	Mbps
$T_J$	Junction temperature <sup>(2)</sup>	-55		150	°C
$T_A$	Ambient temperature	-55	25	125	°C

- (1)  $V_{CCI}$  = Input-side  $V_{CC}$ ;  $V_{CCO}$  = Output-side  $V_{CC}$ .
- (2) To maintain the recommended operating conditions for  $T_J$ , see the [Thermal Information](#) table.

## 6.4 Thermal Information

THERMAL METRIC		SOIC	UNIT
		16 Pins (DW)	
$R_{\theta JA}$	Junction-to-ambient thermal resistance	84.7	°C/W
$R_{\theta JC(top)}$	Junction-to-case(top) thermal resistance	47.3	
$R_{\theta JB}$	Junction-to-board thermal resistance	49.4	
$\Psi_{JT}$	Junction-to-top characterization parameter	19.1	
$\Psi_{JB}$	Junction-to-board characterization parameter	48.8	
$R_{\theta JC(bottom)}$	Junction-to-case(bottom) thermal resistance	n/a	

## 6.5 Power Rating

		VALUE	UNIT
$P_D$	Maximum power dissipation by ISO7810	100	mW
$P_{D1}$	Maximum power dissipation by side-1 of ISO7810	40	
$P_{D2}$	Maximum power dissipation by side-2 of ISO7810	60	

$V_{CC1} = V_{CC2} = 5.5\text{ V}$ ,  $T_J = 150^\circ\text{C}$ ,  $C_L = 15\text{ pF}$ , input a 50 MHz 50% duty cycle square wave

## 6.6 Electrical Characteristics, 5 V

 $V_{CC1} = V_{CC2} = 5\text{ V} \pm 10\%$  (over recommended operating conditions unless otherwise noted)

PARAMETER		TEST CONDITIONS	MIN	TYP	MAX	UNIT
$V_{OH}$	High-level output voltage	$I_{OH} = -4\text{ mA}$ ; see <a href="#">Figure 7</a>	$V_{CCX}^{(1)} - 0.4$	$V_{CCX}^{(1)} - 0.2$		V
$V_{OL}$	Low-level output voltage	$I_{OL} = 4\text{ mA}$ ; see <a href="#">Figure 7</a>		0.2	0.4	V
$V_{I(HYS)}$	Input threshold voltage hysteresis		$0.1 \times V_{CCX}^{(1)}$			V
$I_{IH}$	High-level input current	$V_{IH} = V_{CCX}^{(1)}$ at INx or ENx			10	$\mu\text{A}$
$I_{IL}$	Low-level input current	$V_{IL} = 0\text{ V}$ at INx or ENx	-10			
CMTI	Common-mode transient immunity	$V_I = V_{CCX}^{(1)}$ or 0 V; see <a href="#">Figure 9</a>	50	100		kV/ $\mu\text{s}$
$I_{CC1}$	Supply current	DC Signal	DC signal: $V_I = 0\text{ V}$ (Devices with suffix F), $V_I = V_{CCX}$ (Devices without suffix F)	0.6	1.1	mA
$I_{CC2}$				0.6	1.1	
$I_{CC1}$				1.8	2.7	
$I_{CC2}$				0.7	1.1	
$I_{CC1}$	Supply current	1 Mbps	AC Signal: All channels switching with square wave clock input; $C_L = 15\text{ pF}$	1.2	1.9	mA
$I_{CC2}$				0.6	1.1	
$I_{CC1}$		10 Mbps		1.2	1.9	
$I_{CC2}$				1.1	1.6	
$I_{CC1}$		100 Mbps		1.3	2	
$I_{CC2}$				5.7	6.7	

(1)  $V_{CC1}$  = Input-side  $V_{CC}$ ;  $V_{CC0}$  = Output-side  $V_{CC}$ .

## 6.7 Electrical Characteristics, 3.3 V

 $V_{CC1} = V_{CC2} = 3.3 \text{ V} \pm 10\%$  (over recommended operating conditions unless otherwise noted)

PARAMETER		TEST CONDITIONS	MIN	TYP	MAX	UNIT
$V_{OH}$	High-level output voltage	$I_{OH} = -2 \text{ mA}$ ; see <a href="#">Figure 7</a>	$V_{CCX}^{(1)} - 0.4$	$V_{CCX}^{(1)} - 0.2$		V
$V_{OL}$	Low-level output voltage	$I_{OL} = 2 \text{ mA}$ ; see <a href="#">Figure 7</a>		0.2	0.4	V
$V_{I(HYS)}$	Input threshold voltage hysteresis		$0.1 \times V_{CCX}^{(1)}$			V
$I_{IH}$	High-level input current	$V_{IH} = V_{CCX}^{(1)}$ at INx or ENx			10	$\mu\text{A}$
$I_{IL}$	Low-level input current	$V_{IL} = 0 \text{ V}$ at INx or ENx	-10			
CMTI	Common-mode transient immunity	$V_I = V_{CCX}$ or 0 V; see <a href="#">Figure 9</a>	50	100		kV/ $\mu\text{s}$
$I_{CC1}$	Supply current	DC Signal	DC signal: $V_I = 0 \text{ V}$ (Devices with suffix F), $V_I = V_{CCX}$ (Devices without suffix F)	0.6	1.1	mA
$I_{CC2}$				0.6	1	
$I_{CC1}$				1.8	2.7	
$I_{CC2}$				0.6	1.1	
$I_{CC1}$	Supply current	1 Mbps	AC Signal: All channels switching with square wave clock input; $C_L = 15 \text{ pF}$	1.2	1.9	mA
$I_{CC2}$				0.6	1.1	
$I_{CC1}$		10 Mbps		1.2	1.9	
$I_{CC2}$				0.9	1.4	
$I_{CC1}$		100 Mbps		1.3	2	
$I_{CC2}$				4.1	4.9	

 (1)  $V_{CC1}$  = Input-side  $V_{CC}$ ;  $V_{CC0}$  = Output-side  $V_{CC}$ .

## 6.8 Electrical Characteristics, 2.5 V

 $V_{CC1} = V_{CC2} = 2.5 \text{ V} \pm 10\%$  (over recommended operating conditions unless otherwise noted)

PARAMETER		TEST CONDITIONS	MIN	TYP	MAX	UNIT
$V_{OH}$	High-level output voltage	$I_{OH} = -1 \text{ mA}$ ; see <a href="#">Figure 7</a>	$V_{CCX}^{(1)} - 0.4$	$V_{CCX}^{(1)} - 0.2$		V
$V_{OL}$	Low-level output voltage	$I_{OL} = 1 \text{ mA}$ ; see <a href="#">Figure 7</a>		0.2	0.4	V
$V_{I(HYS)}$	Input threshold voltage hysteresis		$0.1 \times V_{CCX}^{(1)}$			V
$I_{IH}$	High-level input current	$V_{IH} = V_{CCX}^{(1)}$ at INx or ENx			10	$\mu\text{A}$
$I_{IL}$	Low-level input current	$V_{IL} = 0 \text{ V}$ at INx or ENx	-10			
CMTI	Common-mode transient immunity	$V_I = V_{CCX}$ or 0 V; see <a href="#">Figure 9</a>	70	100		kV/ $\mu\text{s}$
$I_{CC1}$	Supply current	DC Signal	DC signal: $V_I = 0 \text{ V}$ (Devices with suffix F), $V_I = V_{CCX}$ (Devices without suffix F)	0.6	1.1	mA
$I_{CC2}$				0.6	1	
$I_{CC1}$				1.8	2.7	
$I_{CC2}$				0.6	1.1	
$I_{CC1}$	Supply current	1 Mbps	AC Signal: All channels switching with square wave clock input; $C_L = 15 \text{ pF}$	1.2	1.9	mA
$I_{CC2}$				0.6	1.1	
$I_{CC1}$		10 Mbps		1.2	1.9	
$I_{CC2}$				0.9	1.3	
$I_{CC1}$		100 Mbps		1.3	2	
$I_{CC2}$				3.3	4.1	

 (1)  $V_{CC1}$  = Input-side  $V_{CC}$ ;  $V_{CC0}$  = Output-side  $V_{CC}$ .

## 6.9 Switching Characteristics, 5 V

 $V_{CC1} = V_{CC2} = 5\text{ V} \pm 10\%$  (over recommended operating conditions unless otherwise noted)

PARAMETER	TEST CONDITIONS	MIN	TYP	MAX	UNIT
$t_{PLH}$ , $t_{PHL}$ Propagation delay time	See Figure 7	6	10.7	16	ns
PWD <sup>(1)</sup> Pulse width distortion $ t_{PHL} - t_{PLH} $			0.6	4.6	
$t_{sk(pp)}$ <sup>(2)</sup> Part-to-part skew time				4.5	ns
$t_r$ Output signal rise time	See Figure 7		2.4	3.9	ns
$t_f$ Output signal fall time				2.4	
$t_{is}$ Default output delay time from input power loss	Measured from the time $V_{CC}$ goes below 1.7 V. See Figure 8		0.2	9	$\mu$ s
$t_{ie}$ Time interval error	$2^{16}$ - 1 PRBS data at 100 Mbps		1		ns

- (1) Also known as Pulse Skew.  
(2)  $t_{sk(pp)}$  is the magnitude of the difference in propagation delay times between any terminals of different devices switching in the same direction while operating at identical supply voltages, temperature, input signals and loads.

## 6.10 Switching Characteristics, 3.3 V

 $V_{CC1} = V_{CC2} = 3.3\text{ V} \pm 10\%$  (over recommended operating conditions unless otherwise noted)

PARAMETER	TEST CONDITIONS	MIN	TYP	MAX	UNIT
$t_{PLH}$ , $t_{PHL}$ Propagation delay time	See Figure 7	6	10.8	16	ns
PWD <sup>(1)</sup> Pulse width distortion $ t_{PHL} - t_{PLH} $				0.7	
$t_{sk(pp)}$ <sup>(2)</sup> Part-to-part skew time				4.5	ns
$t_r$ Output signal rise time	See Figure 7		1.3	3	
$t_f$ Output signal fall time				1.3	3
$t_{is}$ Default output delay time from input power loss	Measured from the time $V_{CC}$ goes below 1.7 V. See Figure 8		0.2	9	$\mu$ s
$t_{ie}$ Time interval error	$2^{16}$ - 1 PRBS data at 100 Mbps		1		ns

- (1) Also known as Pulse Skew.  
(2)  $t_{sk(pp)}$  is the magnitude of the difference in propagation delay times between any terminals of different devices switching in the same direction while operating at identical supply voltages, temperature, input signals and loads.

## 6.11 Switching Characteristics, 2.5 V

 $V_{CC1} = V_{CC2} = 2.5\text{ V} \pm 10\%$  (over recommended operating conditions unless otherwise noted)

PARAMETER	TEST CONDITIONS	MIN	TYP	MAX	UNIT
$t_{PLH}$ , $t_{PHL}$ Propagation delay time	See Figure 7	7.5	11.7	17.5	ns
PWD <sup>(1)</sup> Pulse width distortion $ t_{PHL} - t_{PLH} $				0.7	
$t_{sk(pp)}$ <sup>(2)</sup> Part-to-part skew time				4.5	ns
$t_r$ Output signal rise time	See Figure 7		1.8	3.5	
$t_f$ Output signal fall time				1.8	3.5
$t_{is}$ Default output delay time from input power loss	Measured from the time $V_{CC}$ goes below 1.7 V. See Figure 8		0.2	9	$\mu$ s
$t_{ie}$ Time interval error	$2^{16}$ - 1 PRBS data at 100 Mbps		1		ns

- (1) Also known as Pulse Skew.  
(2)  $t_{sk(pp)}$  is the magnitude of the difference in propagation delay times between any terminals of different devices switching in the same direction while operating at identical supply voltages, temperature, input signals and loads.

### 6.12 Typical Characteristics

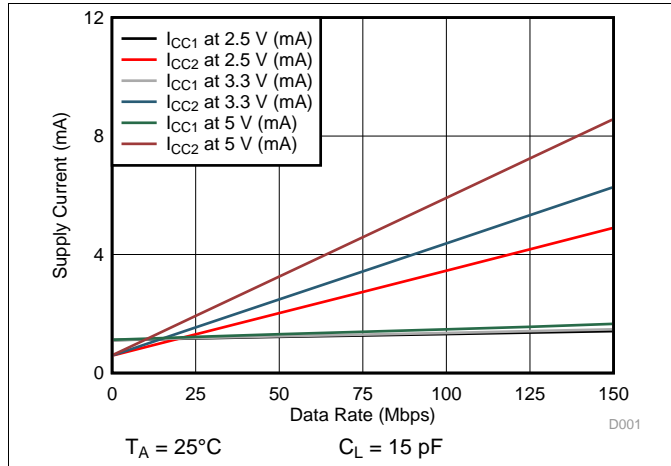

Figure 1. Supply Current vs Data Rate (with 15 pF Load)

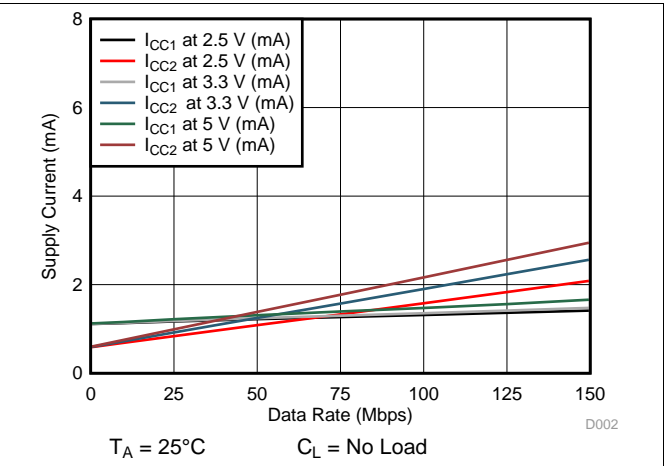

Figure 2. Supply Current vs Data Rate (with No Load)

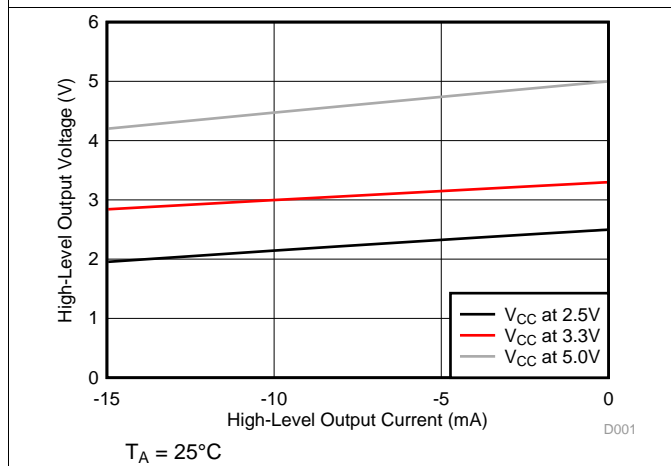

Figure 3. High-Level Output Voltage vs High-level Output Current

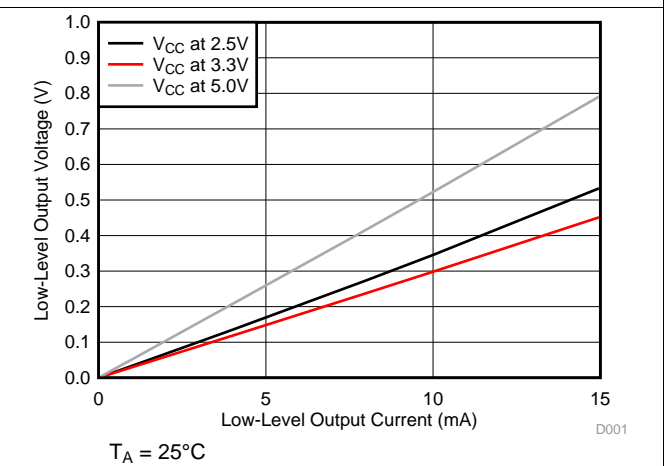

Figure 4. Low-Level Output Voltage vs Low-Level Output Current

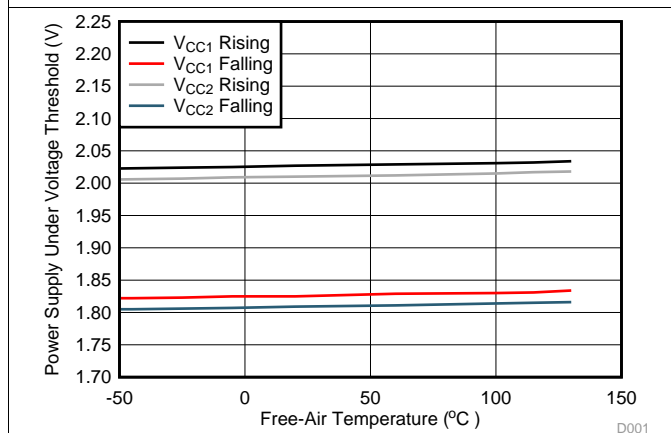

Figure 5. Power Supply Undervoltage Threshold vs Free-Air Temperature

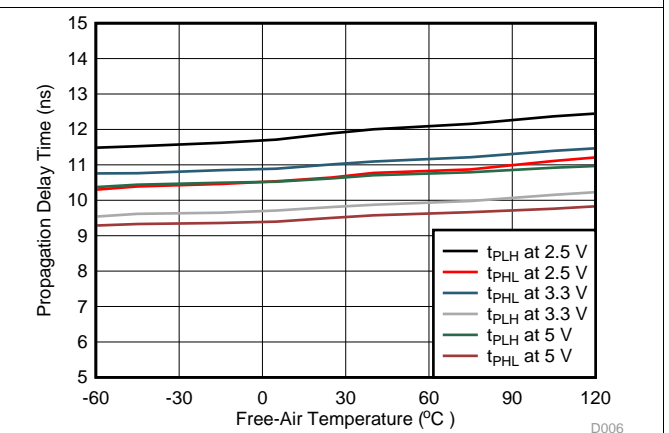
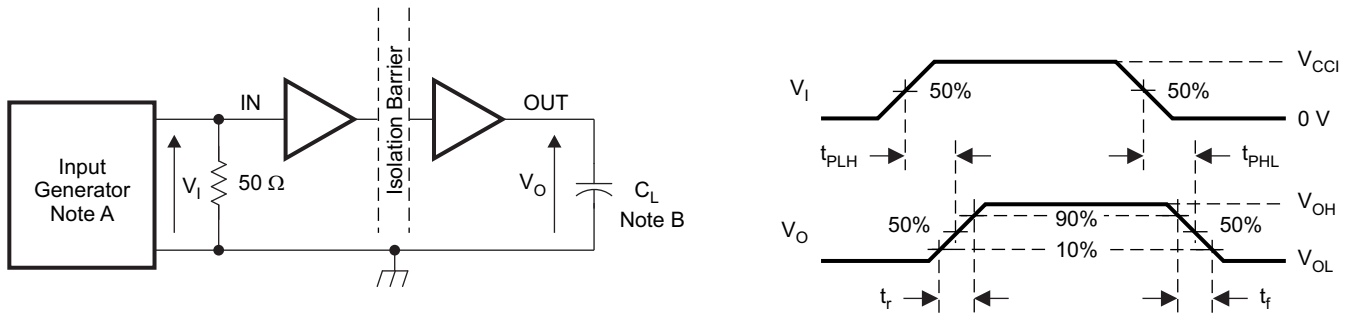

Figure 6. Propagation Delay Time vs Free-Air Temperature

## 7 Parameter Measurement Information



- A. The input pulse is supplied by a generator having the following characteristics: PRR  $\leq$  50 kHz, 50% duty cycle,  $t_r \leq$  3 ns,  $t_f \leq$  3ns,  $Z_O = 50 \Omega$ . At the input,  $50 \Omega$  resistor is required to terminate Input Generator signal. It is not needed in actual application.
- B.  $C_L = 15$  pF and includes instrumentation and fixture capacitance within  $\pm 20\%$ .

**Figure 7. Switching Characteristics Test Circuit and Voltage Waveforms**

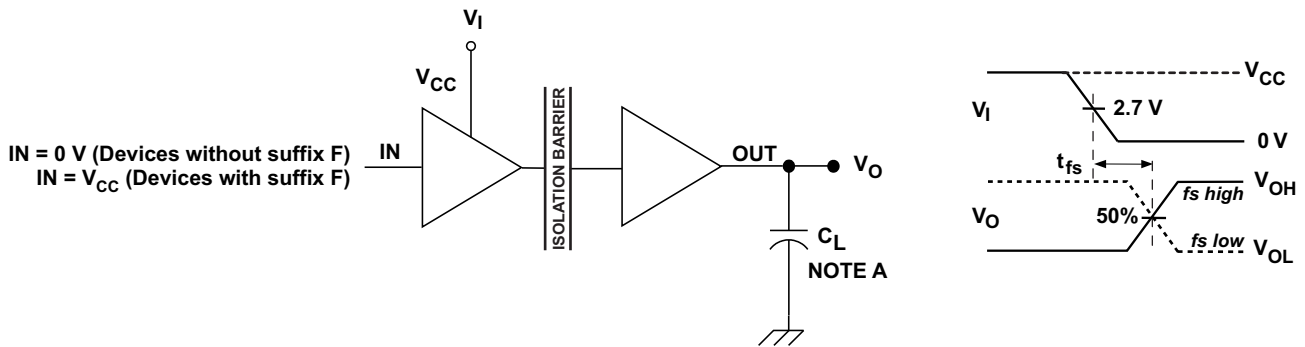

- A.  $C_L = 15$  pF and includes instrumentation and fixture capacitance within  $\pm 20\%$ .

**Figure 8. Default Output Delay Time Test Circuit and Voltage Waveforms**

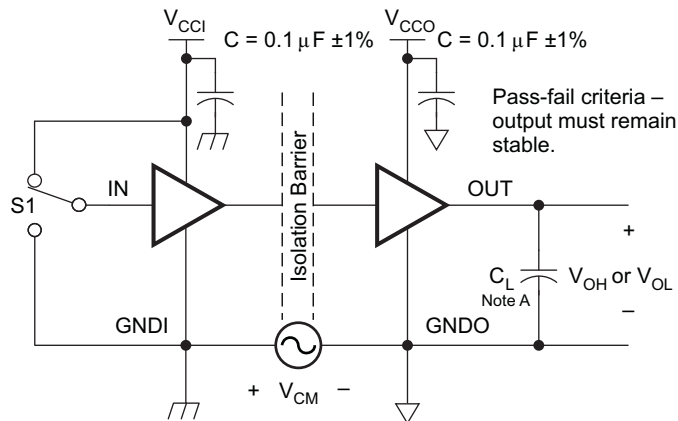

- A.  $C_L = 15$  pF and includes instrumentation and fixture capacitance within  $\pm 20\%$ .

**Figure 9. Common-Mode Transient Immunity Test Circuit**

## 8 Detailed Description

### 8.1 Overview

ISO7810 employs an ON-OFF Keying (OOK) modulation scheme to transmit the digital data across a silicon dioxide based isolation barrier. The transmitter sends a high frequency carrier across the barrier to represent one digital state and sends no signal to represent the other digital state. The receiver demodulates the signal after advanced signal conditioning and produces the output through a buffer stage. These devices also incorporate advanced circuit techniques to maximize the CMTI performance and minimize the radiated emissions due to the high frequency carrier and IO buffer switching. The conceptual block diagram of a digital capacitive isolator, [Figure 10](#), shows a functional block diagram of a typical channel.

### 8.2 Functional Block Diagram

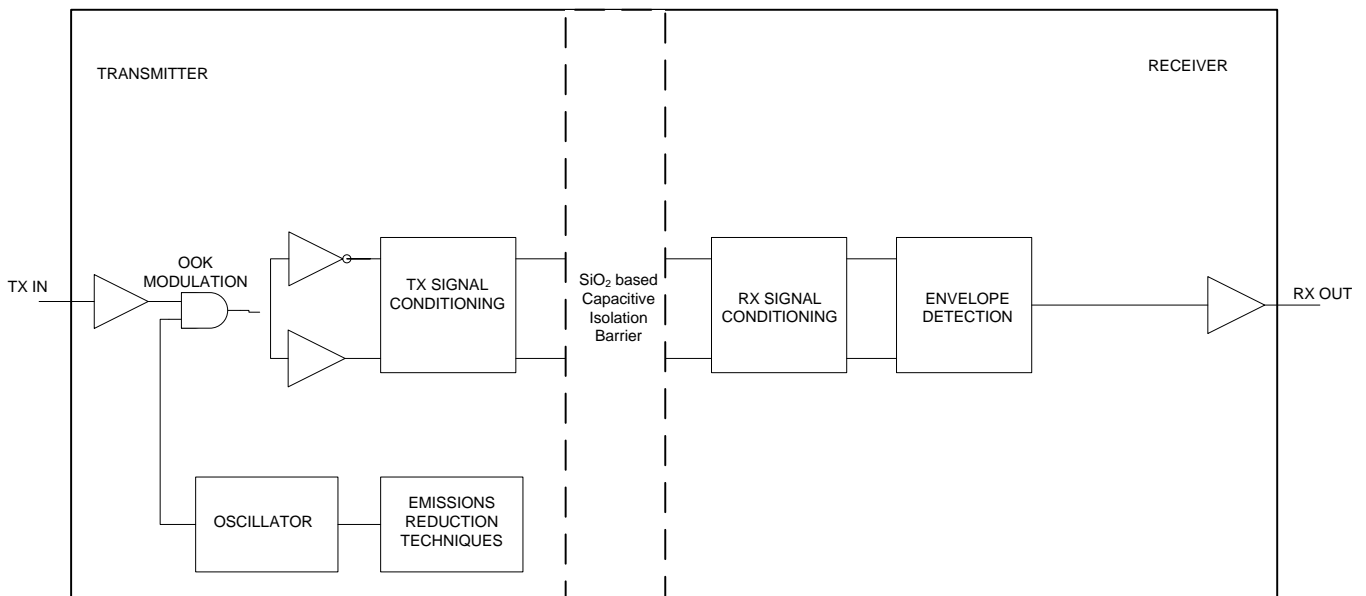

**Figure 10. Conceptual Block Diagram of a Digital Capacitive Isolator**

Also a conceptual detail of how the ON/OFF Keying scheme works is shown in [Figure 11](#).

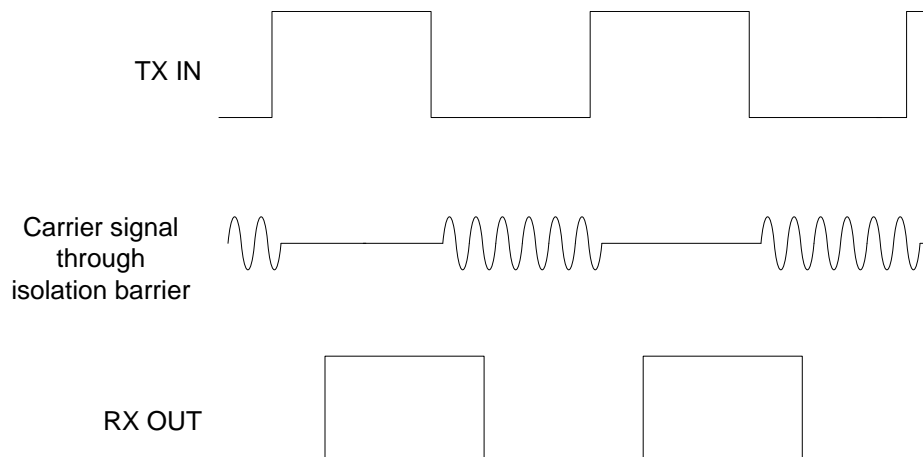

**Figure 11. On-Off Keying (OOK) Based Modulation Scheme**

### 8.3 Feature Description

ISO7810 is available in two channel configurations and default output state options to enable a variety of application uses.

PRODUCT	CHANNEL DIRECTION	RATED ISOLATION	MAX DATA RATE	DEFAULT OUTPUT
ISO7810	1 Forward	5700 V <sub>RMS</sub> / 8000 V <sub>PK</sub> <sup>(1)</sup>	100 Mbps	High
ISO7810F	1 Forward	5700 V <sub>RMS</sub> / 8000 V <sub>PK</sub> <sup>(1)</sup>	100 Mbps	Low

(1) See the [Regulatory Information](#) section for detailed isolation ratings.

#### 8.3.1 High Voltage Feature Description

##### 8.3.1.1 Package Insulation and Safety-Related Specifications

over recommended operating conditions (unless otherwise noted)

PARAMETER		TEST CONDITIONS	MIN	TYP	MAX	UNIT
L(I01)	Minimum air gap (clearance)	Shortest terminal-to-terminal distance through air	DW-16	8		mm
L(I02) <sup>(1)</sup>	Minimum external tracking (creepage)	Shortest terminal-to-terminal distance across the package surface	DW-16	8		mm
CTI	Tracking resistance (comparative tracking index)	DIN EN 60112 (VDE 0303-11); IEC 60112; UL 746A		600		V
R <sub>IO</sub>	Isolation resistance, input to output <sup>(2)</sup>	V <sub>IO</sub> = 500 V, T <sub>A</sub> = 25°C		10 <sup>12</sup>		Ω
		V <sub>IO</sub> = 500 V, 100°C ≤ T <sub>A</sub> ≤ max		10 <sup>11</sup>		Ω
C <sub>IO</sub>	Barrier capacitance, input to output <sup>(2)</sup>	V <sub>IO</sub> = 0.4 x sin (2πft), f = 1 MHz		2		pF
C <sub>I</sub>	Input capacitance <sup>(3)</sup>	V <sub>I</sub> = V <sub>CC</sub> /2 + 0.4 x sin (2πft), f = 1 MHz, V <sub>CC</sub> = 5 V		2		pF

(1) Per JEDEC package dimensions.

(2) All pins on each side of the barrier tied together creating a two-terminal device.

(3) Measured from input pin to ground.

#### NOTE

Creepage and clearance requirements should be applied according to the specific equipment isolation standards of an application. Care should be taken to maintain the creepage and clearance distance of a board design to ensure that the mounting pads of the isolator on the printed-circuit board do not reduce this distance.

Creepage and clearance on a printed-circuit board become equal in certain cases. Techniques such as inserting grooves and/or ribs on a printed circuit board are used to help increase these specifications.

**8.3.1.2 Insulation Characteristics**

PARAMETER <sup>(1)</sup>		TEST CONDITIONS	SPECIFICATION	UNIT
DTI	Distance through the insulation	Minimum internal gap (internal clearance)	21	μm
V <sub>IOWM</sub>	Maximum isolation working voltage	Time dependent dielectric breakdown (TDDB) test	1500	V <sub>RMS</sub>
			2121	V <sub>DC</sub>
<b>DIN V VDE V 0884-10 (VDE V 0884-10):2006-12</b>				
V <sub>IOTM</sub>	Maximum transient isolation voltage	V <sub>TEST</sub> = V <sub>IOTM</sub> t = 60 sec (qualification) t = 1 sec (100% production)	8000	V <sub>PK</sub>
V <sub>IOSM</sub>	Maximum surge isolation voltage	Test method per IEC 60065, 1.2/50 μs waveform, V <sub>TEST</sub> = 1.6 x V <sub>IOSM</sub> = 12800 V <sub>PK</sub> (qualification)	8000	V <sub>PK</sub>
V <sub>IORM</sub>	Maximum repetitive peak isolation voltage		2121	V <sub>PK</sub>
V <sub>PR</sub>	Input-to-output test voltage	Method a, After Input/Output safety test subgroup 2/3, V <sub>PR</sub> = V <sub>IORM</sub> x 1.2, t = 10 s, Partial discharge < 5 pC	2545	V <sub>PK</sub>
		Method a, After environmental tests subgroup 1, V <sub>PR</sub> = V <sub>IORM</sub> x 1.6, t = 10 s, Partial Discharge < 5 pC	3394	
		Method b1, After environmental tests subgroup 1, V <sub>PR</sub> = V <sub>IORM</sub> x 1.875, t = 1 s (100% Production test) Partial discharge < 5 pC	3977	
R <sub>S</sub>	Isolation resistance	V <sub>IO</sub> = 500 V at T <sub>S</sub>	>10 <sup>9</sup>	Ω
	Pollution degree		2	
<b>UL 1577</b>				
V <sub>ISO</sub>	Withstanding isolation voltage	V <sub>TEST</sub> = V <sub>ISO</sub> = 5700 V <sub>RMS</sub> , t = 60 sec (qualification); V <sub>TEST</sub> = 1.2 x V <sub>ISO</sub> = 6840 V <sub>RMS</sub> , t = 1 sec (100% production)	5700	V <sub>RMS</sub>

(1) Climatic Classification 55/125/21

**8.3.1.3 IEC 60664-1 Ratings Table**

PARAMETER		TEST CONDITIONS	SPECIFICATION
Basic isolation group		Material group	I
Installation classification	DW package	Rated mains voltage ≤ 600 V <sub>RMS</sub>	I–IV
		Rated mains voltage ≤ 1000 V <sub>RMS</sub>	I–III

### 8.3.1.4 Regulatory Information

DW package certifications are complete.

VDE	CSA	UL	CQC
Certified according to DIN V VDE V 0884-10 (VDE V 0884-10):2006-12 and DIN EN 60950-1 (VDE 0805 Teil 1):2011-01	Approved under CSA Component Acceptance Notice 5A, IEC 60950-1, IEC 61010-1, and IEC 60601-1	Recognized under UL 1577 Component Recognition Program	Certified according to GB 4943.1-2011
Reinforced insulation Maximum transient isolation voltage, 8000 V <sub>PK</sub> ; Maximum repetitive peak isolation voltage, 2121 V <sub>PK</sub> ; Maximum surge isolation voltage, 8000 V <sub>PK</sub>	Reinforced insulation per CSA 61010-1-12 and IEC 61010-1 3rd Ed., 300 V <sub>RMS</sub> max working voltage;  Reinforced insulation per CSA 60950-1-07+A1+A2 and IEC 60950-1 2nd Ed., 800 V <sub>RMS</sub> max working voltage (pollution degree 2, material group I);  2 MOPP (Means of Patient Protection) per CSA 60601-1:14 and IEC 60601-1 Ed. 3.1, 250 V <sub>RMS</sub> (354 V <sub>PK</sub> ) max working voltage	Single protection, 5700 V <sub>RMS</sub> <sup>(1)</sup>	Reinforced Insulation, Altitude ≤ 5000 m, Tropical Climate, 250 V <sub>RMS</sub> maximum working voltage
Certificate number: 40040142	Master contract number: 220991	File number: E181974	Certificate number: CQC15001121716

(1) Production tested ≥ 6840 V<sub>RMS</sub> for 1 second in accordance with UL 1577.

### 8.3.1.5 Safety Limiting Values

Safety limiting intends to prevent potential damage to the isolation barrier upon failure of input or output circuitry. A failure of the I/O can allow low resistance to ground or the supply and, without current limiting, dissipate sufficient power to overheat the die and damage the isolation barrier potentially leading to secondary system failures.

PARAMETER		TEST CONDITIONS	MIN	TYP	MAX	UNIT
I <sub>S</sub> (DW-16)	Safety input, output, or supply current for DW-16 package	R <sub>θJA</sub> = 84.7°C/W, V <sub>I</sub> = 5.5 V, T <sub>J</sub> = 150°C, T <sub>A</sub> = 25°C			268	mA
		R <sub>θJA</sub> = 84.7°C/W, V <sub>I</sub> = 3.6 V, T <sub>J</sub> = 150°C, T <sub>A</sub> = 25°C			410	
		R <sub>θJA</sub> = 84.7°C/W, V <sub>I</sub> = 2.75 V, T <sub>J</sub> = 150°C, T <sub>A</sub> = 25°C			537	
P <sub>S</sub>	Safety input, output, or total power	R <sub>θJA</sub> = 84.7°C/W, T <sub>J</sub> = 150°C, T <sub>A</sub> = 25°C			1476	mW
T <sub>S</sub>	Maximum case temperature				150	°C

The maximum safety temperature is the maximum junction temperature specified for the device. The power dissipation and junction-to-air thermal impedance of the device installed in the application hardware determines the junction temperature. The assumed junction-to-air thermal resistance in the [Thermal Information](#) is that of a device installed on a High-K test board for Leaded Surface Mount Packages. The power is the recommended maximum input voltage times the current. The junction temperature is then the ambient temperature plus the power times the junction-to-air thermal resistance.

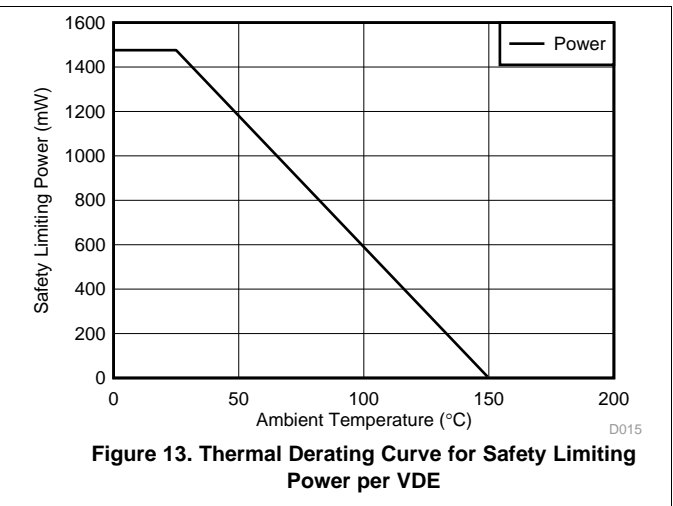
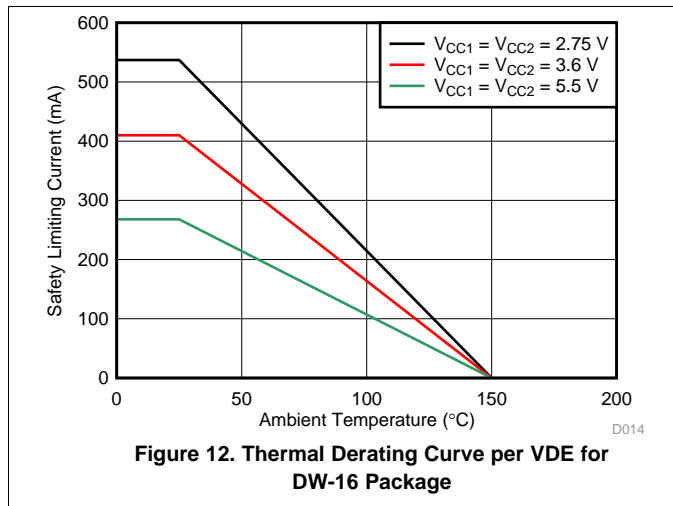

### 8.4 Device Functional Modes

ISO7810DW functional modes are shown in Table 1.

Table 1. ISO7810DW Function Table<sup>(1)</sup>

V <sub>CCI</sub>	V <sub>CCO</sub>	INPUT (IN <sub>x</sub> ) <sup>(2)</sup>	OUTPUT (OUT <sub>x</sub> )	COMMENTS
PU	PU	H	H	Normal Operation: A channel output assumes the logic state of its input.
		L	L	
		Open	Default	Default mode: When IN <sub>x</sub> is open, the corresponding channel output goes to its default high logic state. Default= High for ISO7810 and Low for ISO7810F.
PD	PU	X	Default	Default mode: When V <sub>CCI</sub> is unpowered, a channel output assumes the logic state based on the selected default option. Default= High for ISO7810 and Low for ISO7810F. When V <sub>CCI</sub> transitions from unpowered to powered-up, a channel output assumes the logic state of its input. When V <sub>CCI</sub> transitions from powered-up to unpowered, channel output assumes the selected default state.
X	PD	X	Undetermined	When V <sub>CCO</sub> is unpowered, a channel output is undetermined <sup>(3)</sup> . When V <sub>CCO</sub> transitions from unpowered to powered-up, a channel output assumes the logic state of its input

- (1) V<sub>CCI</sub> = Input-side V<sub>CC</sub>; V<sub>CCO</sub> = Output-side V<sub>CC</sub>; PU = Powered up (V<sub>CC</sub> ≥ 2.25 V); PD = Powered down (V<sub>CC</sub> ≤ 1.7 V); X = Irrelevant; H = High level; L = Low level
- (2) A strongly driven input signal can weakly power the floating V<sub>CC</sub> via an internal protection diode and cause undetermined output.
- (3) The outputs are in undetermined state when 1.7 V < V<sub>CCI</sub>, V<sub>CCO</sub> < 2.25 V.

#### 8.4.1 Device I/O Schematics

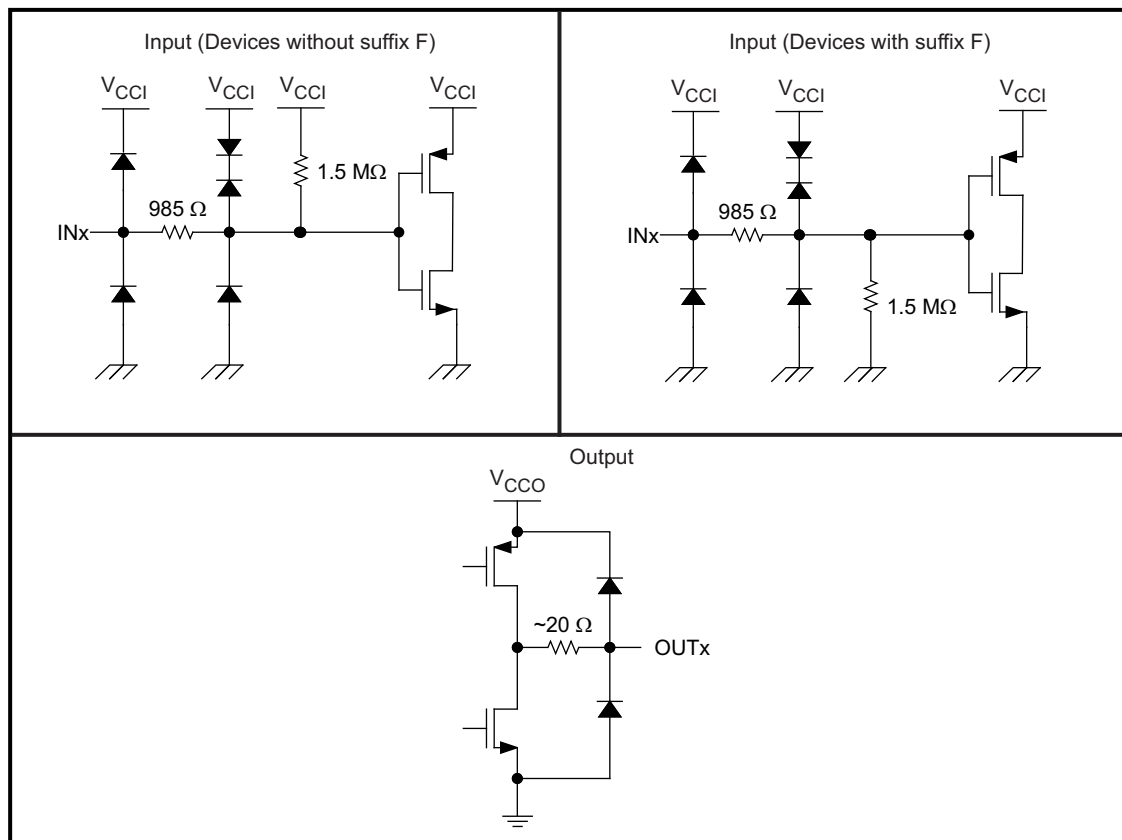

Figure 14. Device I/O Schematics

## 9 Applications and Implementation

### NOTE

Information in the following applications sections is not part of the TI component specification, and TI does not warrant its accuracy or completeness. TI's customers are responsible for determining suitability of components for their purposes. Customers should validate and test their design implementation to confirm system functionality.

### 9.1 Application Information

The ISO7810 is a high-performance, dual-channel digital isolator with 5.7 kV<sub>RMS</sub> isolation voltage. It utilizes single-ended CMOS-logic switching technology. Its supply voltage range is from 2.25 V to 5.5 V for both supplies, V<sub>CC1</sub> and V<sub>CC2</sub>. When designing with digital isolators, it is important to keep in mind that due to the single-ended design structure, digital isolators do not conform to any specific interface standard and are only intended for isolating single-ended CMOS or TTL digital signal lines. The isolator is typically placed between the data controller (that is,  $\mu$ C or UART), and a data converter or a line transceiver, regardless of the interface type or standard.

### 9.2 Typical Application

ISO7810DW can be used with Texas Instruments' mixed signal micro-controller, gatedrivers, transformer driver, and voltage regulator to create an isolated MOSFET/IGBT drive circuit.

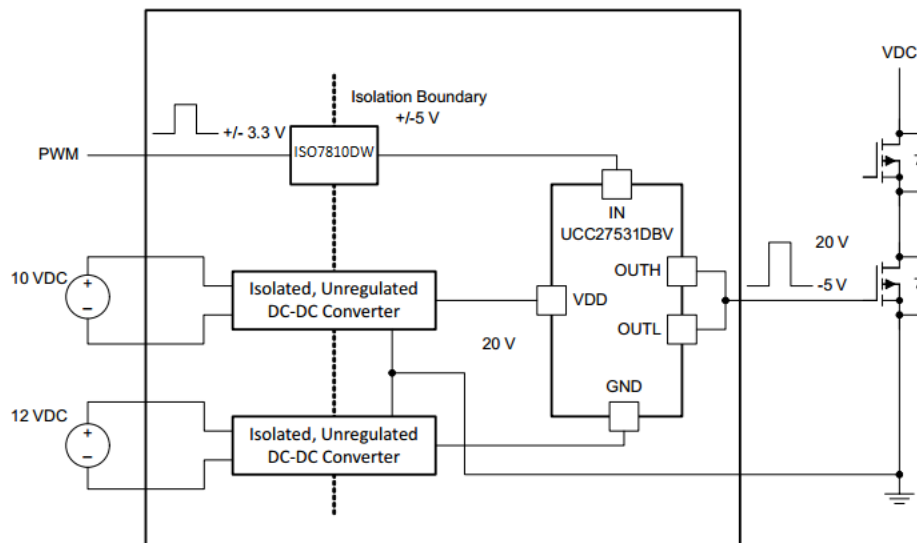

**Figure 15. Low Side Gate Driver Hookup**

#### 9.2.1 Design Requirements

For the ISO7810, use the parameters shown in [Table 2](#).

**Table 2. Design Parameters**

PARAMETER	VALUE
Supply voltage	2.25 V to 5.5 V
Decoupling capacitor between V <sub>CC1</sub> and GND1	0.1 $\mu$ F
Decoupling capacitor from V <sub>CC2</sub> and GND2	0.1 $\mu$ F

### 9.2.2 Detailed Design Procedure

Unlike optocouplers, which need external components to improve performance, provide bias, or limit current, ISO7810 only needs two external bypass capacitors to operate.

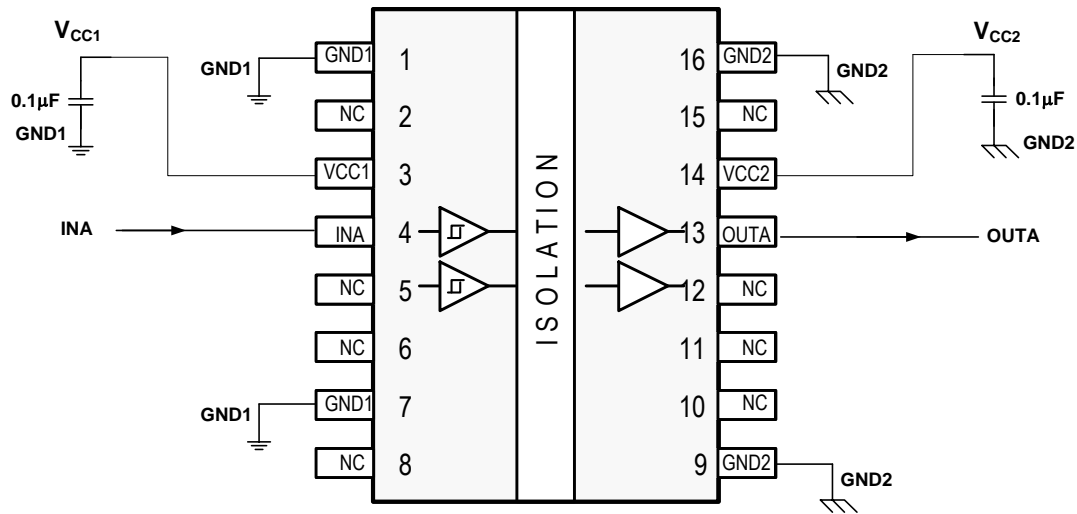

**Figure 16. Typical ISO7810DW Circuit Hook-up**

#### 9.2.2.1 Electromagnetic Compatibility (EMC) Considerations

Many applications in harsh industrial environment are sensitive to disturbances such as electrostatic discharge (ESD), electrical fast transient (EFT), surge and electromagnetic emissions. These electromagnetic disturbances are regulated by international standards such as IEC 61000-4-x and CISPR 22. Although system-level performance and reliability depends, to a large extent, on the application board design and layout, the ISO7810 incorporate many chip-level design improvements for overall system robustness. Some of these improvements include:

- Robust ESD protection for input and output signal pins and inter-chip bond pads.
- Low-resistance connectivity of ESD cells to supply and ground pins.
- Enhanced performance of high voltage isolation capacitor for better tolerance of ESD, EFT and surge events.
- Bigger on-chip decoupling capacitors to bypass undesirable high energy signals through a low impedance path.
- PMOS and NMOS devices isolated from each other by using guard rings to avoid triggering of parasitic SCRs.
- Reduced common mode currents across the isolation barrier by ensuring purely differential internal operation.

### 9.2.3 Application Performance Curve

Typical eye diagram of ISO7810 indicate low jitter and wide open eye at the maximum data rate of 100 Mbps.

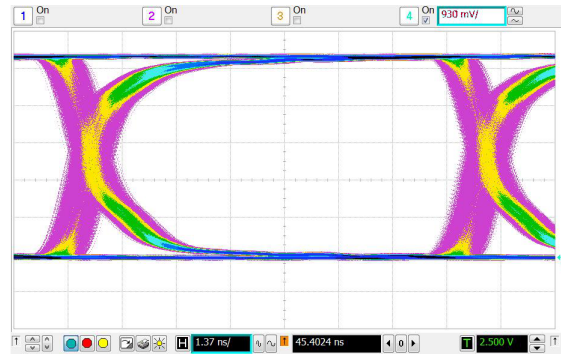

**Figure 17. Eye Diagram at 100 Mbps PRBS, 5 V and 25°C**

## 10 Power Supply Recommendations

To ensure reliable operation at all data rates and supply voltages, a 0.1  $\mu\text{F}$  bypass capacitor is recommended at input and output supply pins ( $V_{CC1}$  and  $V_{CC2}$ ). The capacitors should be placed as close to the supply pins as possible. If only a single primary-side power supply is available in an application, isolated power can be generated for the secondary-side with the help of a transformer driver such as Texas Instruments' [SN6501](#). For such applications, detailed power supply design and transformer selection recommendations are available in [SN6501](#) datasheet ([SLLSEA0](#)) .

## 11 Layout

### 11.1 PCB Material

For digital circuit boards operating below 150 Mbps, (or rise and fall times higher than 1 ns), and trace lengths of up to 10 inches, use standard FR-4 epoxy-glass as PCB material. FR-4 (Flame Retardant 4) meets the requirements of Underwriters Laboratories UL94-V0, and is preferred over cheaper alternatives due to its lower dielectric losses at high frequencies, less moisture absorption, greater strength and stiffness, and its self-extinguishing flammability-characteristics.

### 11.2 Layout Guidelines

A minimum of four layers is required to accomplish a low EMI PCB design (see [Figure 18](#)). Layer stacking should be in the following order (top-to-bottom): high-speed signal layer, ground plane, power plane and low-frequency signal layer.

- Routing the high-speed traces on the top layer avoids the use of vias (and the introduction of their inductances) and allows for clean interconnects between the isolator and the transmitter and receiver circuits of the data link.
- Placing a solid ground plane next to the high-speed signal layer establishes controlled impedance for transmission line interconnects and provides an excellent low-inductance path for the return current flow.
- Placing the power plane next to the ground plane creates additional high-frequency bypass capacitance of approximately 100 pF/in<sup>2</sup>.
- Routing the slower speed control signals on the bottom layer allows for greater flexibility as these signal links usually have margin to tolerate discontinuities such as vias.

If an additional supply voltage plane or signal layer is needed, add a second power / ground plane system to the stack to keep it symmetrical. This makes the stack mechanically stable and prevents it from warping. Also the power and ground plane of each power system can be placed closer together, thus increasing the high-frequency bypass capacitance significantly.

For detailed layout recommendations, see Application Note [SLLA284](#), *Digital Isolator Design Guide*.

### 11.3 Layout Example

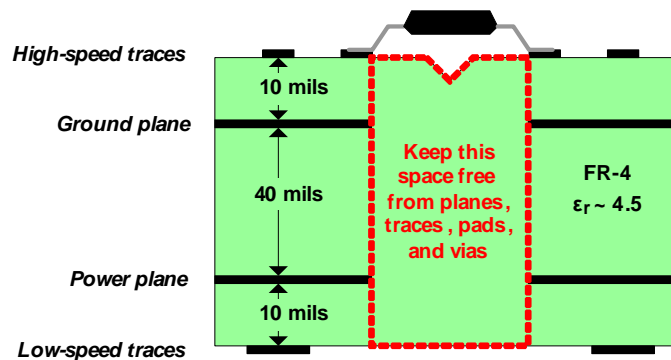

**Figure 18. Layout Example**

## 12 器件和文档支持

### 12.1 文档支持

#### 12.1.1 相关文档

请参见 [隔离术语表 \(SLLA353\)](#)

### 12.2 相关链接

下面的表格列出了快速访问链接。 范围包括技术文档、支持和社区资源、工具和软件，以及样片或购买的快速访问。

表 3. 相关链接

器件	产品文件夹	样片与购买	技术文档	工具与软件	支持与社区
ISO7810	<a href="#">请单击此处</a>	<a href="#">请单击此处</a>	<a href="#">请单击此处</a>	<a href="#">请单击此处</a>	<a href="#">请单击此处</a>
ISO7810F	<a href="#">请单击此处</a>	<a href="#">请单击此处</a>	<a href="#">请单击此处</a>	<a href="#">请单击此处</a>	<a href="#">请单击此处</a>

### 12.3 社区资源

The following links connect to TI community resources. Linked contents are provided "AS IS" by the respective contributors. They do not constitute TI specifications and do not necessarily reflect TI's views; see TI's [Terms of Use](#).

**TI E2E™ Online Community *TI's Engineer-to-Engineer (E2E) Community*.** Created to foster collaboration among engineers. At [e2e.ti.com](#), you can ask questions, share knowledge, explore ideas and help solve problems with fellow engineers.

**Design Support *TI's Design Support*** Quickly find helpful E2E forums along with design support tools and contact information for technical support.

### 12.4 商标

E2E is a trademark of Texas Instruments.  
All other trademarks are the property of their respective owners.

### 12.5 静电放电警告



这些装置包含有限的内置 ESD 保护。 存储或装卸时，应将导线一起截短或将装置放置于导电泡棉中，以防止 MOS 门极遭受静电损伤。

### 12.6 Glossary

[SLYZ022](#) — *TI Glossary*.

This glossary lists and explains terms, acronyms, and definitions.

## 13 机械、封装和可订购信息

以下页中包括机械、封装和可订购信息。 这些信息是针对指定器件可提供的最新数据。 这些数据会在无通知且不对本文档进行修订的情况下发生改变。 欲获得该数据表的浏览器版本，请查阅左侧的导航栏。

**PACKAGING INFORMATION**

Orderable Device	Status (1)	Package Type	Package Drawing	Pins	Package Qty	Eco Plan (2)	Lead finish/ Ball material (6)	MSL Peak Temp (3)	Op Temp (°C)	Device Marking (4/5)	Samples
ISO7810DW	ACTIVE	SOIC	DW	16	40	RoHS & Green	NIPDAU	Level-2-260C-1 YEAR	-55 to 125	ISO7810	<a href="#">Samples</a>
ISO7810DWR	ACTIVE	SOIC	DW	16	2000	RoHS & Green	NIPDAU	Level-2-260C-1 YEAR	-55 to 125	ISO7810	<a href="#">Samples</a>
ISO7810DWW	ACTIVE	SOIC	DWW	16	45	RoHS & Green	NIPDAU	Level-3-260C-168 HR	-55 to 125	ISO7810	<a href="#">Samples</a>
ISO7810DWWR	ACTIVE	SOIC	DWW	16	1000	RoHS & Green	NIPDAU	Level-3-260C-168 HR	-55 to 125	ISO7810	<a href="#">Samples</a>
ISO7810FDW	ACTIVE	SOIC	DW	16	40	RoHS & Green	NIPDAU	Level-2-260C-1 YEAR	-55 to 125	ISO7810F	<a href="#">Samples</a>
ISO7810FDWR	ACTIVE	SOIC	DW	16	2000	RoHS & Green	NIPDAU	Level-2-260C-1 YEAR	-55 to 125	ISO7810F	<a href="#">Samples</a>
ISO7810FDWW	ACTIVE	SOIC	DWW	16	45	RoHS & Green	NIPDAU	Level-3-260C-168 HR	-55 to 125	ISO7810F	<a href="#">Samples</a>
ISO7810FDWWR	ACTIVE	SOIC	DWW	16	1000	RoHS & Green	NIPDAU	Level-3-260C-168 HR	-55 to 125	ISO7810F	<a href="#">Samples</a>

(1) The marketing status values are defined as follows:

**ACTIVE:** Product device recommended for new designs.

**LIFEBUY:** TI has announced that the device will be discontinued, and a lifetime-buy period is in effect.

**NRND:** Not recommended for new designs. Device is in production to support existing customers, but TI does not recommend using this part in a new design.

**PREVIEW:** Device has been announced but is not in production. Samples may or may not be available.

**OBSELETE:** TI has discontinued the production of the device.

(2) **RoHS:** TI defines "RoHS" to mean semiconductor products that are compliant with the current EU RoHS requirements for all 10 RoHS substances, including the requirement that RoHS substance do not exceed 0.1% by weight in homogeneous materials. Where designed to be soldered at high temperatures, "RoHS" products are suitable for use in specified lead-free processes. TI may reference these types of products as "Pb-Free".

**RoHS Exempt:** TI defines "RoHS Exempt" to mean products that contain lead but are compliant with EU RoHS pursuant to a specific EU RoHS exemption.

**Green:** TI defines "Green" to mean the content of Chlorine (Cl) and Bromine (Br) based flame retardants meet JS709B low halogen requirements of <=1000ppm threshold. Antimony trioxide based flame retardants must also meet the <=1000ppm threshold requirement.

(3) MSL, Peak Temp. - The Moisture Sensitivity Level rating according to the JEDEC industry standard classifications, and peak solder temperature.

(4) There may be additional marking, which relates to the logo, the lot trace code information, or the environmental category on the device.

(5) Multiple Device Markings will be inside parentheses. Only one Device Marking contained in parentheses and separated by a "~" will appear on a device. If a line is indented then it is a continuation of the previous line and the two combined represent the entire Device Marking for that device.

<sup>(6)</sup> Lead finish/Ball material - Orderable Devices may have multiple material finish options. Finish options are separated by a vertical ruled line. Lead finish/Ball material values may wrap to two lines if the finish value exceeds the maximum column width.

**Important Information and Disclaimer:** The information provided on this page represents TI's knowledge and belief as of the date that it is provided. TI bases its knowledge and belief on information provided by third parties, and makes no representation or warranty as to the accuracy of such information. Efforts are underway to better integrate information from third parties. TI has taken and continues to take reasonable steps to provide representative and accurate information but may not have conducted destructive testing or chemical analysis on incoming materials and chemicals. TI and TI suppliers consider certain information to be proprietary, and thus CAS numbers and other limited information may not be available for release.

In no event shall TI's liability arising out of such information exceed the total purchase price of the TI part(s) at issue in this document sold by TI to Customer on an annual basis.

**TAPE AND REEL INFORMATION**

**QUADRANT ASSIGNMENTS FOR PIN 1 ORIENTATION IN TAPE**



\*All dimensions are nominal

Device	Package Type	Package Drawing	Pins	SPQ	Reel Diameter (mm)	Reel Width W1 (mm)	A0 (mm)	B0 (mm)	K0 (mm)	P1 (mm)	W (mm)	Pin1 Quadrant
ISO7810DWR	SOIC	DW	16	2000	330.0	16.4	10.75	10.7	2.7	12.0	16.0	Q1
ISO7810DWWR	SOIC	DWW	16	1000	330.0	24.4	18.0	10.0	3.0	20.0	24.0	Q1
ISO7810FDWR	SOIC	DW	16	2000	330.0	16.4	10.75	10.7	2.7	12.0	16.0	Q1
ISO7810FDWWR	SOIC	DWW	16	1000	330.0	24.4	18.0	10.0	3.0	20.0	24.0	Q1

**TAPE AND REEL BOX DIMENSIONS**

\*All dimensions are nominal

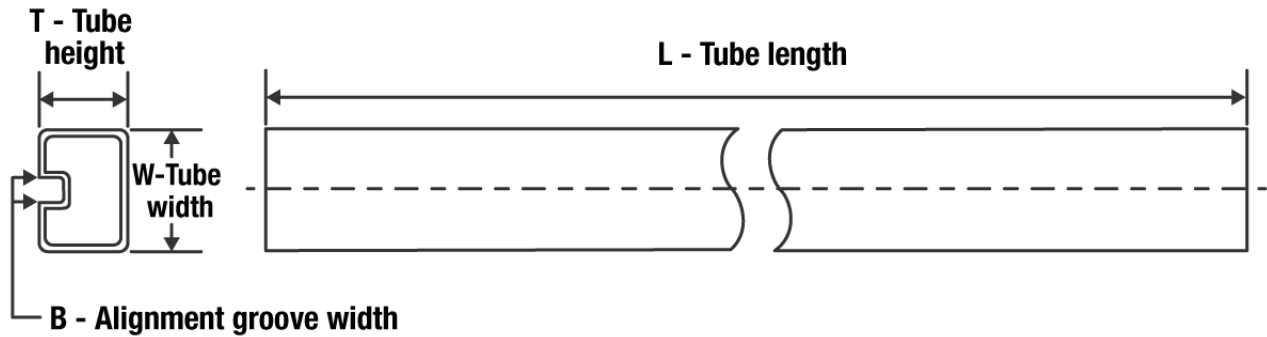
Device	Package Type	Package Drawing	Pins	SPQ	Length (mm)	Width (mm)	Height (mm)
ISO7810DWR	SOIC	DW	16	2000	350.0	350.0	43.0
ISO7810DWWR	SOIC	DWW	16	1000	350.0	350.0	43.0
ISO7810FDWR	SOIC	DW	16	2000	350.0	350.0	43.0
ISO7810FDWWR	SOIC	DWW	16	1000	350.0	350.0	43.0

**TUBE**

\*All dimensions are nominal

Device	Package Name	Package Type	Pins	SPQ	L (mm)	W (mm)	T (μm)	B (mm)
ISO7810DW	DW	SOIC	16	40	506.98	12.7	4826	6.6
ISO7810DWW	DWW	SOIC	16	45	507	20	5000	9
ISO7810FDW	DW	SOIC	16	40	506.98	12.7	4826	6.6
ISO7810FDWW	DWW	SOIC	16	45	507	20	5000	9

## 重要声明和免责声明

TI“按原样”提供技术和可靠性数据（包括数据表）、设计资源（包括参考设计）、应用或其他设计建议、网络工具、安全信息和其他资源，不保证没有瑕疵且不做任何明示或暗示的担保，包括但不限于对适销性、某特定用途方面的适用性或不侵犯任何第三方知识产权的暗示担保。

这些资源可供使用 TI 产品进行设计的熟练开发人员使用。您将自行承担以下全部责任：(1) 针对您的应用选择合适的 TI 产品，(2) 设计、验证并测试您的应用，(3) 确保您的应用满足相应标准以及任何其他功能安全、信息安全、监管或其他要求。

这些资源如有变更，恕不另行通知。TI 授权您仅可将这些资源用于研发本资源所述的 TI 产品的应用。严禁对这些资源进行其他复制或展示。您无权使用任何其他 TI 知识产权或任何第三方知识产权。您应全额赔偿因在这些资源的使用中对 TI 及其代表造成的任何索赔、损害、成本、损失和债务，TI 对此概不负责。

TI 提供的产品受 [TI 的销售条款](#) 或 [ti.com](#) 上其他适用条款/TI 产品随附的其他适用条款的约束。TI 提供这些资源并不会扩展或以其他方式更改 TI 针对 TI 产品发布的适用的担保或担保免责声明。

TI 反对并拒绝您可能提出的任何其他或不同的条款。

邮寄地址：Texas Instruments, Post Office Box 655303, Dallas, Texas 75265

Copyright © 2022，德州仪器 (TI) 公司