

LM1894 Dynamic Noise Reduction System DNR

Check for Samples: [LM1894](#)

FEATURES

- **Non-Complementary Noise Reduction, “Single Ended”**
- **Low Cost External Components, No Critical Matching**
- **Compatible with All Prerecorded Tapes and FM**
- **10 dB Effective Tape Noise Reduction CCIR/ARM Weighted**
- **Wide Supply Range, 4.5V to 18V**
- **1 Vrms Input Overload**

APPLICATIONS

- **Automotive Radio/Tape Players**
- **Compact Portable Tape Players**
- **Quality HI-FI Tape Systems**
- **VCR Playback Noise Reduction**
- **Video Disc Playback Noise Reduction**

DESCRIPTION

The LM1894 is a stereo noise reduction circuit for use with audio playback systems. The DNR system is non-complementary, meaning it does not require encoded source material. The system is compatible with virtually all pre-recorded tapes and FM broadcasts. Psychoacoustic masking, and an adaptive bandwidth scheme allow the DNR to achieve 10 dB of noise reduction. DNR can save circuit board space and cost because of the few additional components required.



Please be aware that an important notice concerning availability, standard warranty, and use in critical applications of Texas Instruments semiconductor products and disclaimers thereto appears at the end of this data sheet.

All trademarks are the property of their respective owners.

Typical Application

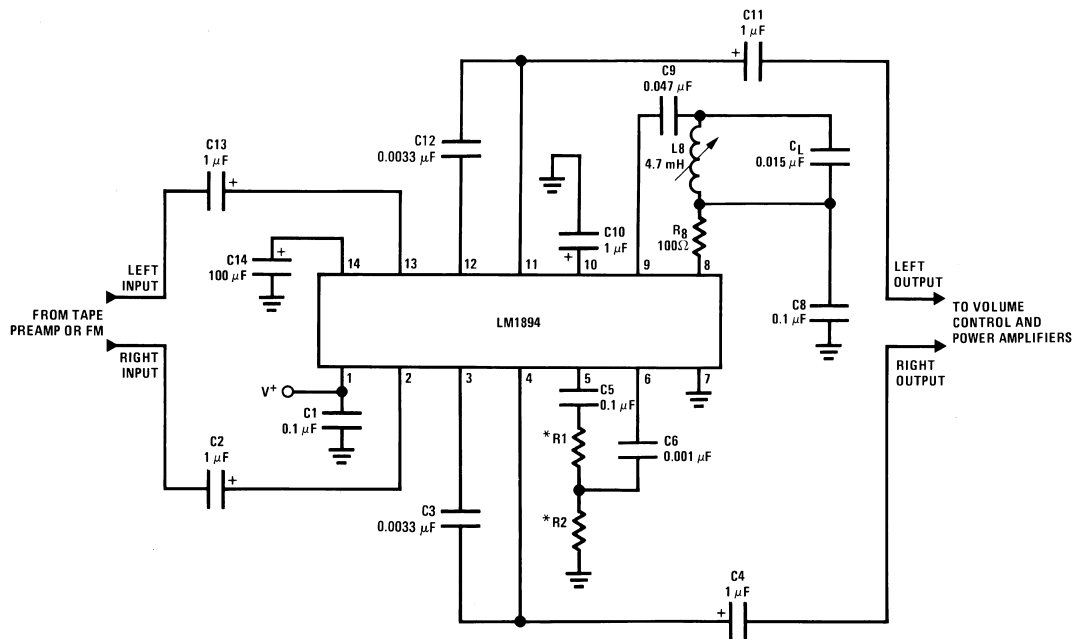

*R1 + R2 = 1 kΩ total.
See [Application Hints](#).

Figure 1. Component Hook-Up for Stereo DNR System
14-Pin SOIC or PDIP or TSSOP
 See D or NFF0014A or PW Package



These devices have limited built-in ESD protection. The leads should be shorted together or the device placed in conductive foam during storage or handling to prevent electrostatic damage to the MOS gates.

Absolute Maximum Ratings⁽¹⁾⁽²⁾

Supply Voltage			20V
Input Voltage Range, V_{pk}			$V_S/2$
Operating Temperature ⁽³⁾			0°C to +70°C
Storage Temperature			-65°C to +150°C
Soldering Information	PDIP Package	Soldering (10 seconds)	260°C
	SOIC Package	Vapor Phase (60 seconds)	215°C
		Infrared (15 seconds)	220°C

- (1) "Absolute Maximum Ratings" indicate limits beyond which damage to the device may occur. Operating Ratings indicate conditions for which the device is functional, but do not ensure specific performance limits.
- (2) If Military/Aerospace specified devices are required, please contact the Texas Instruments Sales Office/Distributors for availability and specifications.
- (3) For operation in ambient temperature above 25°C, the device must be derated based on a 150°C maximum junction temperature and a thermal resistance of:
 - (a) 80°C/W junction to ambient for the PDIP package,
 - (b) 105°C/W junction to ambient for the SOIC package, and
 - (c) 150°C/W junction to ambient for the TSSOP package.

Electrical Characteristics

$V_S = 8V$, $T_A = 25^\circ C$, $V_{IN} = 300\text{ mV}$ at 1 kHz, circuit shown in [Figure 1](#) unless otherwise specified

Parameter	Conditions	Min	Typ	Max	Units
Operating Supply Range		4.5	8	18	V
Supply Current	$V_S = 8V$		17	30	mA
MAIN SIGNAL PATH					
Voltage Gain	DC Ground Pin 9 ⁽¹⁾	-0.9	-1	-1.1	V/V
DC Output Voltage		3.7	4.0	4.3	V
Channel Balance	DC Ground Pin 9	-1.0		1.0	dB
Minimum Balance	AC Ground Pin 9 with 0.1 μF Capacitor ⁽¹⁾	675	965	1400	Hz
Maximum Bandwidth	DC Ground Pin 9 ⁽¹⁾	27	34	46	kHz
Effective Noise Reduction	CCIR/ARM Weighted ⁽²⁾		-10	-14	dB
Total Harmonic Distortion	DC Ground Pin 9		0.05	0.1	%
Input Headroom	Maximum V_{IN} for 3% THD AC Ground Pin 9		1.0		V _{rms}
Output Headroom	Maximum V_{OUT} for 3% THD DC Ground Pin 9		$V_S - 1.5$		V _{p-p}
Signal to Noise	BW = 20 Hz–20 kHz, re 300 mV AC Ground Pin 9		79		dB
	DC Ground Pin 9		77		dB
	CCIR/ARM Weighted re 300 mV ⁽³⁾ AC Ground Pin 9	82	88		dB
	DC Ground Pin 9	70	76		dB
	CCIR Peak, re 300 mV ⁽⁴⁾ AC Ground Pin 9		77		dB
	DC Ground Pin 9		64		dB
Input Impedance	Pin 2 and Pin 13	14	20	26	k Ω
Channel Separation	DC Ground Pin 9	-50	-70		dB
Power Supply Rejection	C14 = 100 μF , $V_{RIPPLE} = 500\text{ mV}_{rms}$, $f = 1\text{ kHz}$	-40	-56		dB
Output DC Shift	Reference DVM to Pin 14 and Measuree Output DC Shift from Minimum to Maximum Band-width ⁽⁵⁾		4.0	20	mV

- (1) To force the DNR system into maximum bandwidth, DC ground the input to the peak detector, pin 9. A negative temperature coefficient of $-0.5\%/^\circ C$ on the bandwidth, reduces the maximum bandwidth at increased ambient temperature or higher package dissipation. AC ground pin 9 or pin 6 to select minimum bandwidth. To change minimum and maximum bandwidth, see [Application Hints](#).
- (2) The maximum noise reduction CCIR/ARM weighted is about 14 dB. This is accomplished by changing the bandwidth from maximum to minimum. In actual operation, minimum bandwidth is not selected, a nominal minimum bandwidth of about 2 kHz gives -10 dB of noise reduction. See [Application Hints](#).
- (3) The CCIR/ARM weighted noise is measured with a 40 dB gain amplifier between the DNR system and the CCIR weighting filter; it is then input referred.
- (4) Measured using the Rhode-Schwartz psophometer.
- (5) Pin 10 is DC forced half way between the maximum bandwidth DC level and minimum bandwidth DC level. An AC 1 kHz signal is then applied to pin 10. Its peak-to-peak amplitude is $V_{DC}(\text{max BW}) - V_{DC}(\text{min BW})$.

Electrical Characteristics (continued)

$V_S = 8V$, $T_A = 25^\circ C$, $V_{IN} = 300\text{ mV}$ at 1 kHz, circuit shown in [Figure 1](#) unless otherwise specified

Parameter	Conditions	Min	Typ	Max	Units
CONTROL SIGNAL PATH					
Summing Amplifier Voltage Gain	Both Channels Driven	0.9	1	1.1	V/V
Gain Amplifier Input Impedance	Pin 6	24	30	39	k Ω
Voltage Gain	Pin 6 to Pin 8	21.5	24	26.5	V/V
Peak Detector Input Impedance	Pin 9	560	700	840	Ω
Voltage Gain	Pin 9 to Pin 10	30	33	36	V/V
Attack Time	Measured to 90% of Final Value with 10 kHz Tone Burst	300	500	700	μs
Decay Time	Measured to 90% of Final Value with 10 kHz Tone Burst	45	60	75	ms
DC Voltage Range	Minimum Bandwidth to Maximum Bandwidth	1.1		3.8	V

Typical Performance Characteristics

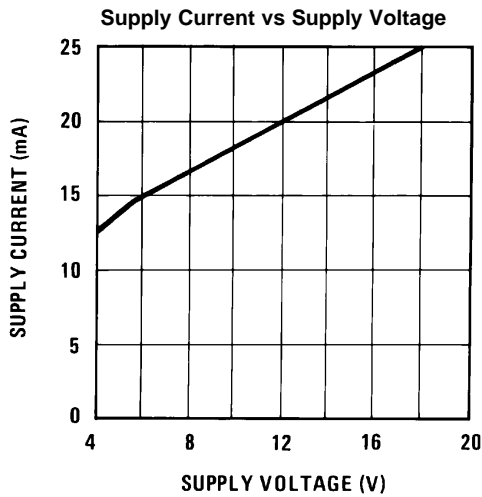

Figure 2.

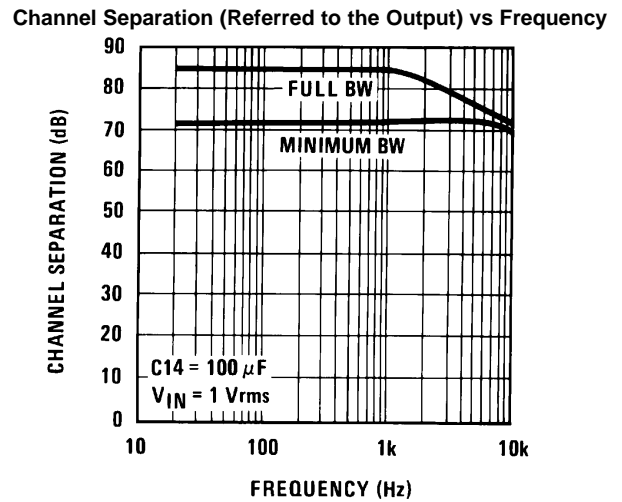

Figure 3.

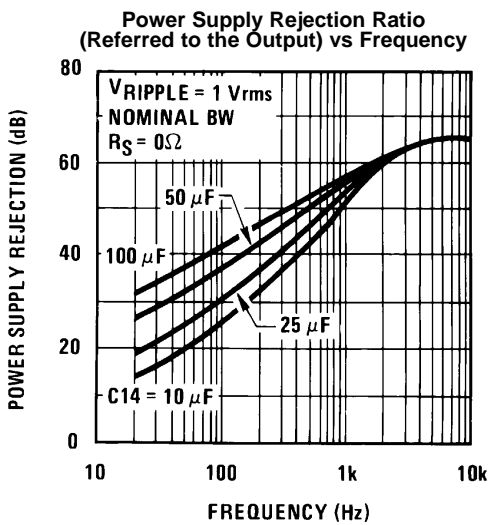

Figure 4.

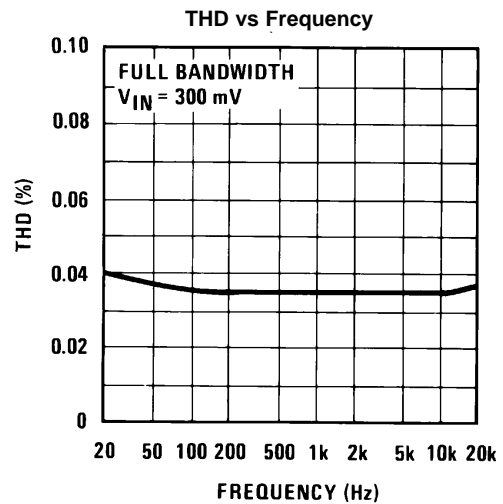

Figure 5.

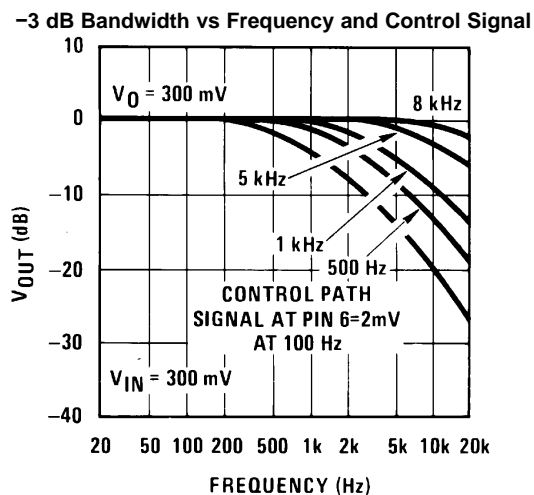

Figure 6.

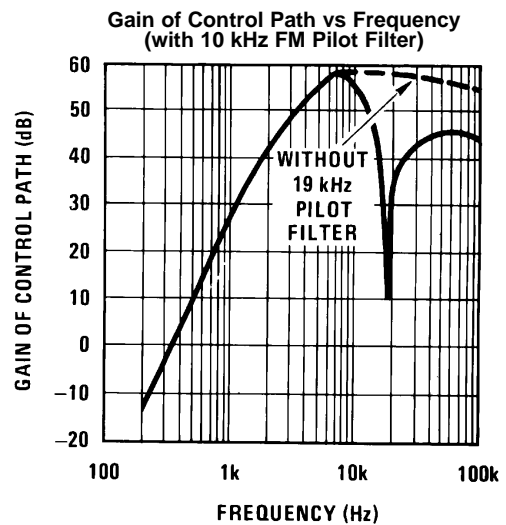
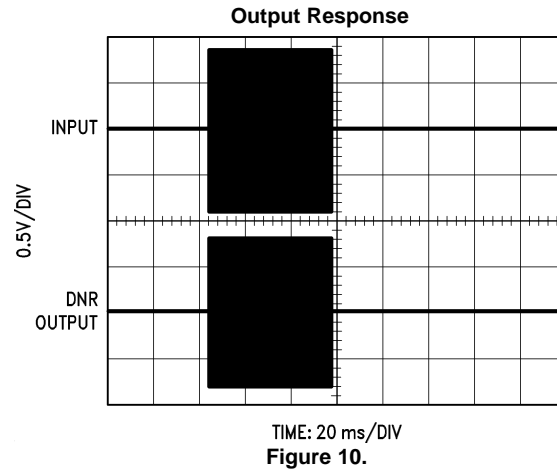
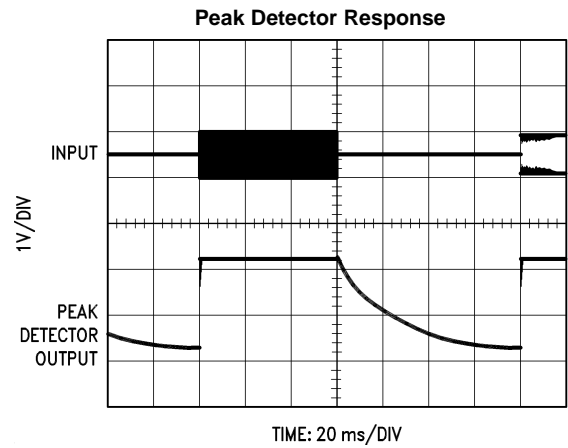
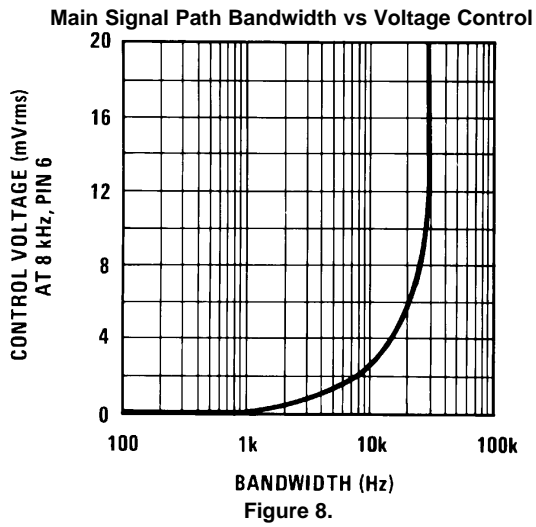

Figure 7.

Typical Performance Characteristics (continued)



External Component Guide

(Figure 1)

Component	Value	Purpose
C1	0.1 μ F–100 μ F	May be part of power supply, or may be added to suppress power supply oscillation.
C2, C13	1 μ F	Blocks DC, pin 2 and pin 13 are at DC potential of $V_S/2$. C2, C13 form a low frequency pole with 20k R_{IN} . $f_L = \frac{1}{2\pi C2 R_{IN}}$
C14	25 μ F–100 μ F	Improves power supply rejection.
C3, C12	0.0033 μ F	Forms integrator with internal gm block and op amp. Sets bandwidth conversion gain of 33 Hz/ μ A of gm current.
C4, C11	1 μ F	Output coupling capacitor. Output is at DC potential of $V_S/2$.
C5	0.1 μ F	Works with R1 and R2 to attenuate low frequency transients which could disturb control path operation. $f_5 = \frac{1}{2\pi C5 (R1 + R2)} = 1.6 \text{ kHz}$
C6	0.001 μ F	Works with input resistance of pin 6 to form part of control path frequency weighting. $f_6 = \frac{1}{2\pi C6 R1_{PIN\ 6}} = 5.3 \text{ kHz}$
C8	0.1 μ F	Combined with L8 and C_L forms 19 kHz filter for FM pilot. This is only required in FM applications ⁽¹⁾ .
L8, C_L	4.7 mH, 0.015 μ F	Forms 19 kHz filter for FM pilot. L8 is Toko coil CAN-1A185HM ⁽¹⁾⁽²⁾ .
C9	0.047 μ F	Works with input resistance of pin 9 to form part of control path frequency weighting. $f_9 = \frac{1}{2\pi C9 R_{PIN\ 9}} = 4.8 \text{ kHz}$
C10	1 μ F	Set attack and decay time of peak detector.
R1, R2	1 k Ω	Sensitivity resistors set the noise threshold. Reducing attenuation causes larger signals to be peak detected and larger bandwidth in main signal path. Total value of R1 + R2 should equal 1 k Ω .
R8	100 Ω	Forms RC roll-off with C8. This is only required in FM applications.

(1) When FM applications are not required, pin 8 and pin 9 hook-up as follows:

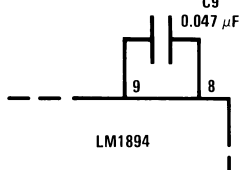

(2) Toko America Inc., 1250 Feehanville Drive, Mt. Prospect IL 60056

Circuit Operation

The LM1894 has two signal paths, a main signal path and a bandwidth control path. The main path is an audio low pass filter comprised of a gm block with a variable current, and an op amp configured as an integrator. As seen in [Figure 11](#), DC feedback constrains the low frequency gain to $A_V = -1$. Above the cutoff frequency of the filter, the output decreases at -6 dB/oct due to the action of the 0.0033 μ F capacitor.

The purpose of the control paths is to generate a bandwidth control signal which replicates the ear's sensitivity to noise in the presence of a tone. A single control path is used for both channels to keep the stereo image from wandering. This is done by adding the right and left channels together in the summing amplifier of [Figure 11](#). The R1, R2 resistor divider adjusts the incoming noise level to open slightly the bandwidth of the low pass filter. Control path gain is about 60 dB and is set by the gain amplifier and peak detector gain. This large gain is needed to ensure the low pass filter bandwidth can be opened by very low noise floors. The capacitors between

the summing amplifier output and the peak detector input determine the frequency weighting as shown in the [Typical Performance Characteristics](#). The 1 μF capacitor at pin 10, in conjunction with internal resistors, sets the attack and decay times. The voltage is converted into a proportional current which is fed into the gm blocks. The bandwidth sensitivity to gm current is 33 Hz/ μA . In FM stereo applications at 19 kHz pilot filter is inserted between pin 8 and pin 9 as shown in [Figure 1](#).

[Figure 12](#) is an interesting curve and deserves some discussion. Although the output of the DNR system is a linear function of input signal, the -3 dB bandwidth is not. This is due to the non-linear nature of the control path. The DNR system has a uniform frequency response, but looking at the -3 dB bandwidth on a steady state basis with a single frequency input can be misleading. It must be remembered that a single input frequency can only give a single -3 dB bandwidth and the roll-off from this point must be a smooth -6 dB/oct.

A more accurate evaluation of the frequency response can be seen in [Figure 13](#). In this case the main signal path is frequency swept, while the control path has a constant frequency applied. It can be seen that different control path frequencies each give a distinctive gain roll-off.

PSYCHOACOUSTIC BASICS

The dynamic noise reduction system is a low pass filter that has a variable bandwidth of 1 kHz to 30 kHz, dependent on music spectrum. The DNR system operates on three principles of psychoacoustics.

1. White noise can mask pure tones. The total noise energy required to mask a pure tone must equal the energy of the tone itself. Within certain limits, the wider the band of masking noise about the tone, the lower the noise amplitude need be. As long as the total energy of the noise is equal to or greater than the energy of the tone, the tone will be inaudible. This principle may be turned around; when music is present, it is capable of masking noise in the same bandwidth.
2. The ear cannot detect distortion for less than 1 ms. On a transient basis, if distortion occurs in less than 1 ms, the ear acts as an integrator and is unable to detect it. Because of this, signals of sufficient energy to mask noise open bandwidth to 90% of the maximum value in less than 1 ms. Reducing the bandwidth to within 10% of its minimum value is done in about 60 ms: long enough to allow the ambience of the music to pass through, but not so long as to allow the noise floor to become audible.
3. Reducing the audio bandwidth reduces the audibility of noise. Audibility of noise is dependent on noise spectrum, or how the noise energy is distributed with frequency. Depending on the tape and the recorder equalization, tape noise spectrum may be slightly rolled off with frequency on a per octave basis. The ear sensitivity on the other hand greatly increases between 2 kHz and 10 kHz. Noise in this region is extremely audible. The DNR system low pass filters this noise. Low frequency music will not appreciably open the DNR bandwidth, thus 2 kHz to 20 kHz noise is not heard.

Block Diagram

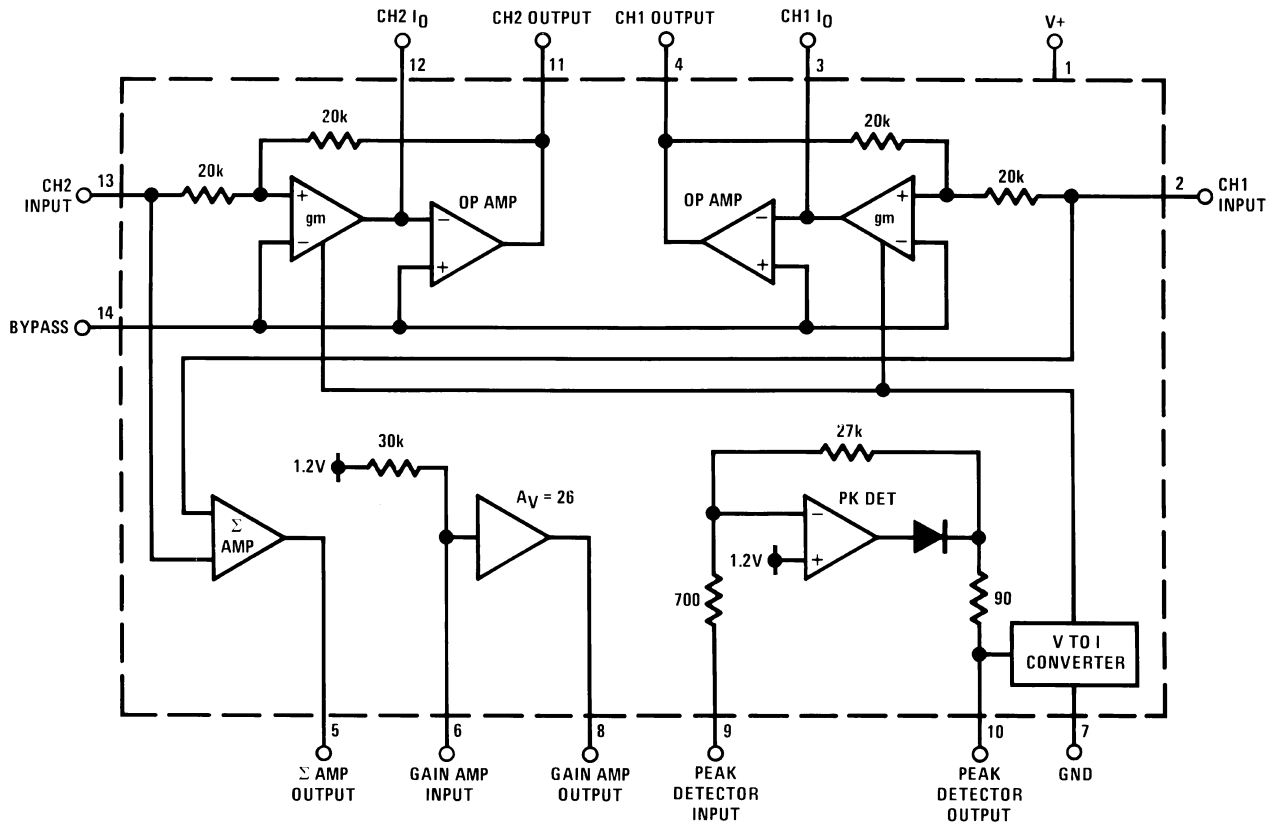

Figure 11.

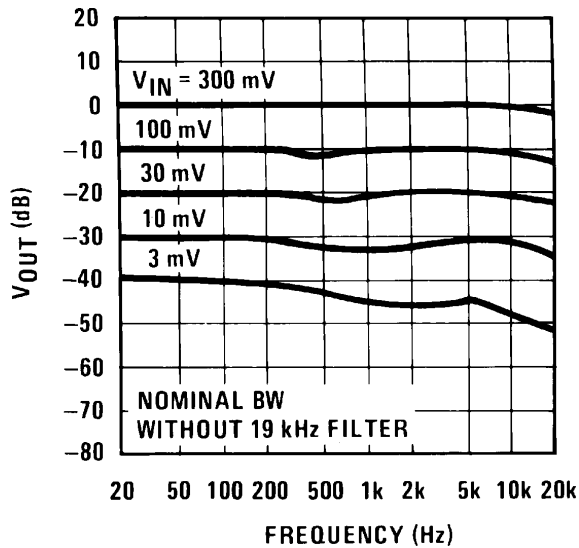

Figure 12. Output vs Frequency

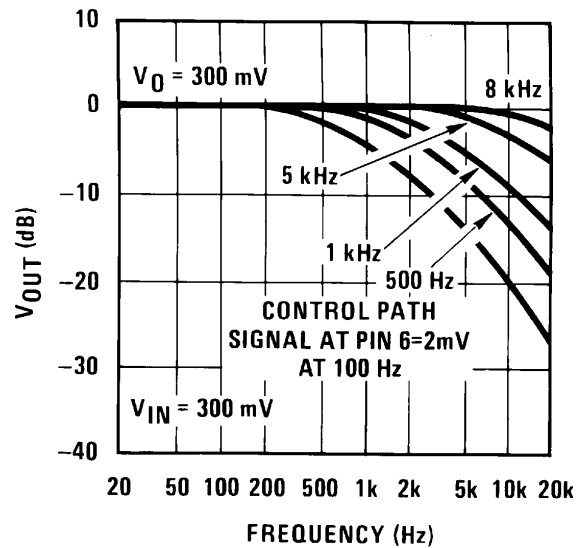

Figure 13. -3 dB Bandwidth vs Frequency and Control Signal

APPLICATION HINTS

The DNR system should always be placed before tone and volume controls as shown in [Figure 1](#). This is because any adjustment of these controls would alter the noise floor seen by the DNR control path. The sensitivity resistors R1 and R2 may need to be switched with the input selector, depending on the noise floors of different sources, i.e., tape, FM, phono. To determine the value of R1 and R2 in a tape system for instance; apply tape noise (no program material) and adjust the ratio of R1 and R2 to open slightly the bandwidth of the main signal path. This can easily be done by viewing the capacitor voltage of pin 10 with an oscilloscope, or by using the circuit of [Figure 14](#). This circuit gives an LED display of the voltage on the peak detector capacitor. Adjust the values of R1 and R2 (their sum is always 1 k Ω) to light the LEDs of pin 1 and pin 18. The LED bar graph does not indicate signal level, but rather instantaneous bandwidth of the two filters; it should not be used as a signal-level indicator. For greater flexibility in setting the bandwidth sensitivity, R1 and R2 could be replaced by a 1 k Ω potentiometer.

To change the minimum and maximum value of bandwidth, the integrating capacitors, C3 and C12, can be scaled up or down. Since the bandwidth is inversely proportional to the capacitance, changing this 0.0039 μ F capacitor to 0.0033 μ F will change the typical bandwidth from 965 Hz–34 kHz to 1.1 kHz–40 kHz. With C3 and C12 set at 0.0033 μ F, the maximum bandwidth is typically 34 kHz. A double pole double throw switch can be used to completely bypass DNR.

The capacitor on pin 10 in conjunction with internal resistors sets the attack and decay times. The attack time can be altered by changing the size of C10. Decay times can be decreased by paralleling a resistor with C10, and increased by increasing the value of C10.

When measuring the amount of noise reduction of the DNR system, the frequency response of the cassette should be flat to 10 kHz. The CCIR weighting network has substantial gain to 8 kHz and any additional roll-off in the cassette player will reduce the benefits of DNR noise reduction. A typical signal-to-noise measurement circuit is shown in [Figure 15](#). The DNR system should be switched from maximum bandwidth to nominal bandwidth with tape noise as a signal source. The reduction in measured noise is the signal-to-noise ratio improvement.

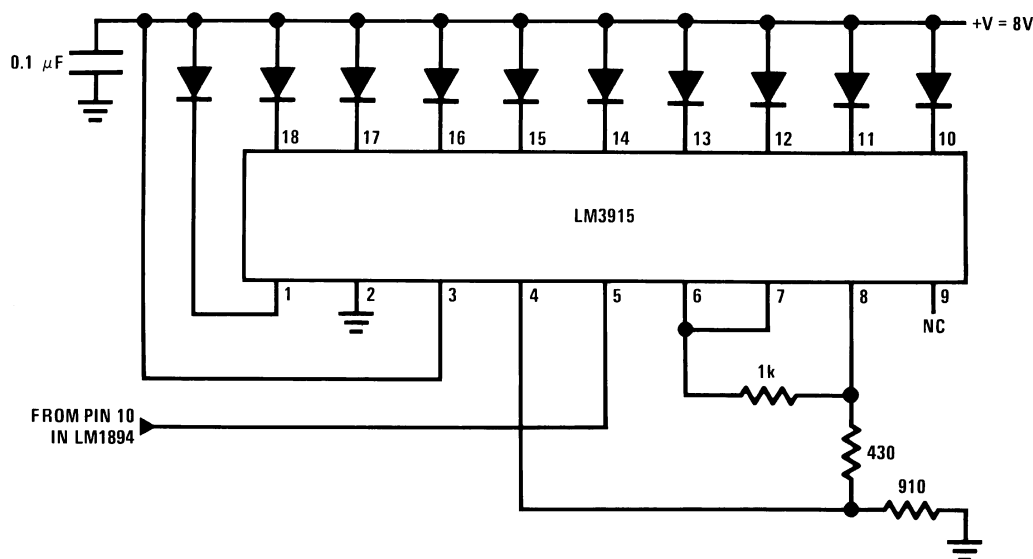

Figure 14. Bar Graph Display of Peak Detector Voltage

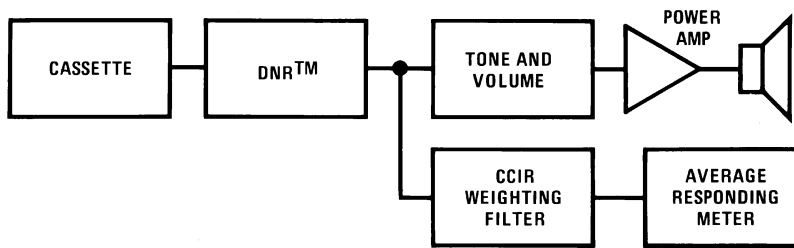

Figure 15. Technique for Measuring S/N Improvement of the DNR System

FOR FURTHER READING

Tape Noise Levels

1. "A Wide Range Dynamic Noise Reduction System", Blackmer, *"dB" Magazine*, August-September 1972, Volume 6, #8.
2. "Dolby B-Type Noise Reduction System", Berkowitz and Gundry, *Sert Journal*, May-June 1974, Volume 8.
3. "Cassette vs Elcaset vs Open Reel", Toole, *Audioscene Canada*, April 1978.
4. "CCIR/ARM: A Practical Noise Measurement Method", Dolby, Robinson, Gundry, *JAES*, 1978.

Noise Masking

1. "Masking and Discrimination", Bos and De Boer, *JAES*, Volume 39, #4, 1966.
2. "The Masking of Pure Tones and Speech by White Noise", Hawkins and Stevens, *JAES*, Volume 22, #1, 1950.
3. "Sound System Engineering", Davis Howard W. Sams and Co.
4. "High Quality Sound Reproduction", Moir, Chapman Hall, 1960.
5. "Speech and Hearing in Communication", Fletcher, Van Nostrand, 1953.

Printed Circuit Layout

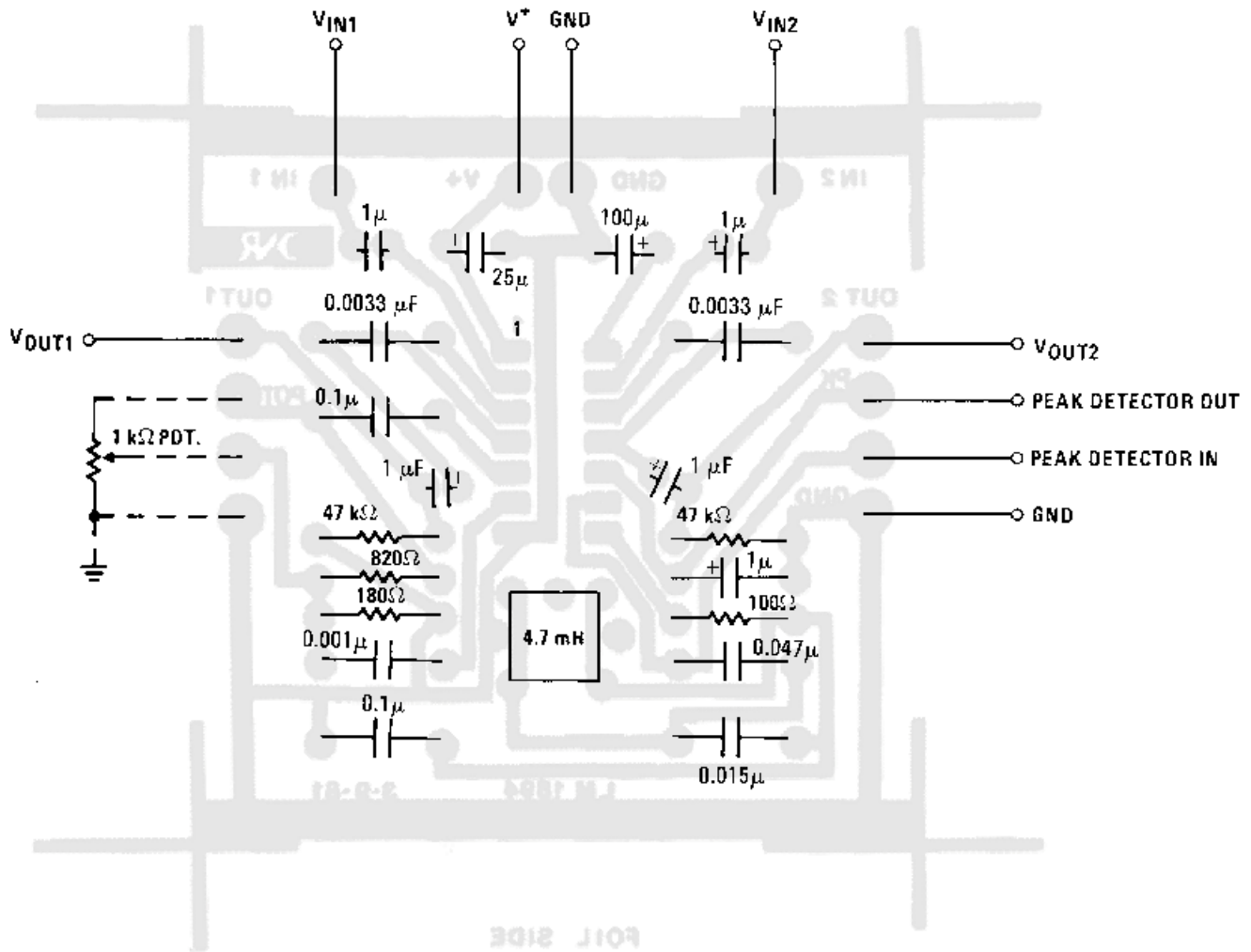

Figure 16. DNR Component Diagram

REVISION HISTORY

Changes from Revision B (April 2013) to Revision C	Page
• Changed layout of National Data Sheet to TI format	11

PACKAGING INFORMATION

Orderable Device	Status (1)	Package Type	Package Drawing	Pins	Package Qty	Eco Plan (2)	Lead finish/ Ball material (6)	MSL Peak Temp (3)	Op Temp (°C)	Device Marking (4/5)	Samples
LM1894MX/NOPB	ACTIVE	SOIC	D	14	2500	RoHS & Green	SN	Level-1-260C-UNLIM	0 to 70	LM1894M	Samples

(1) The marketing status values are defined as follows:

ACTIVE: Product device recommended for new designs.

LIFEBUY: TI has announced that the device will be discontinued, and a lifetime-buy period is in effect.

NRND: Not recommended for new designs. Device is in production to support existing customers, but TI does not recommend using this part in a new design.

PREVIEW: Device has been announced but is not in production. Samples may or may not be available.

OBSOLETE: TI has discontinued the production of the device.

(2) **RoHS:** TI defines "RoHS" to mean semiconductor products that are compliant with the current EU RoHS requirements for all 10 RoHS substances, including the requirement that RoHS substance do not exceed 0.1% by weight in homogeneous materials. Where designed to be soldered at high temperatures, "RoHS" products are suitable for use in specified lead-free processes. TI may reference these types of products as "Pb-Free".

RoHS Exempt: TI defines "RoHS Exempt" to mean products that contain lead but are compliant with EU RoHS pursuant to a specific EU RoHS exemption.

Green: TI defines "Green" to mean the content of Chlorine (Cl) and Bromine (Br) based flame retardants meet JS709B low halogen requirements of <=1000ppm threshold. Antimony trioxide based flame retardants must also meet the <=1000ppm threshold requirement.

(3) MSL, Peak Temp. - The Moisture Sensitivity Level rating according to the JEDEC industry standard classifications, and peak solder temperature.

(4) There may be additional marking, which relates to the logo, the lot trace code information, or the environmental category on the device.

(5) Multiple Device Markings will be inside parentheses. Only one Device Marking contained in parentheses and separated by a "-" will appear on a device. If a line is indented then it is a continuation of the previous line and the two combined represent the entire Device Marking for that device.

(6) Lead finish/Ball material - Orderable Devices may have multiple material finish options. Finish options are separated by a vertical ruled line. Lead finish/Ball material values may wrap to two lines if the finish value exceeds the maximum column width.

Important Information and Disclaimer:The information provided on this page represents TI's knowledge and belief as of the date that it is provided. TI bases its knowledge and belief on information provided by third parties, and makes no representation or warranty as to the accuracy of such information. Efforts are underway to better integrate information from third parties. TI has taken and continues to take reasonable steps to provide representative and accurate information but may not have conducted destructive testing or chemical analysis on incoming materials and chemicals. TI and TI suppliers consider certain information to be proprietary, and thus CAS numbers and other limited information may not be available for release.

In no event shall TI's liability arising out of such information exceed the total purchase price of the TI part(s) at issue in this document sold by TI to Customer on an annual basis.

TAPE AND REEL INFORMATION

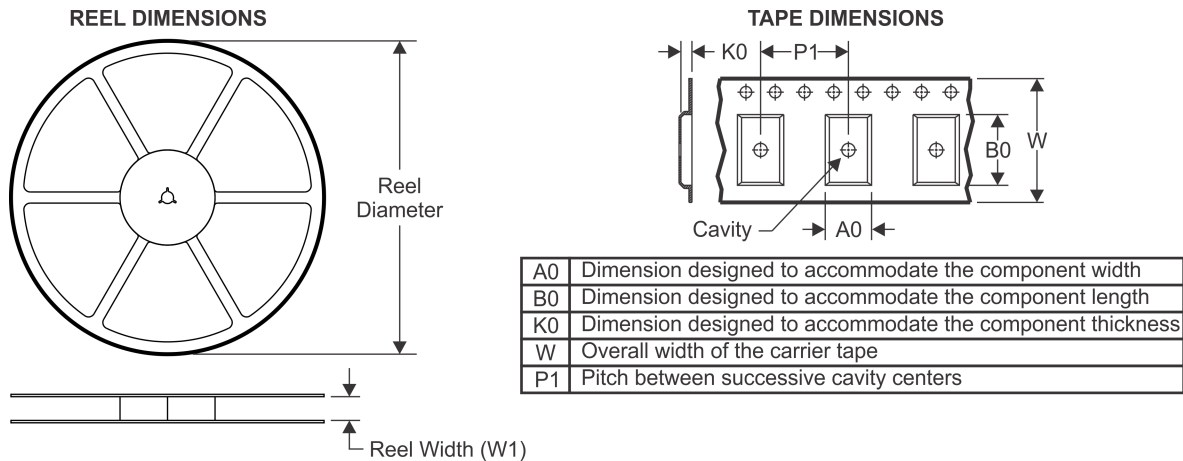

QUADRANT ASSIGNMENTS FOR PIN 1 ORIENTATION IN TAPE



*All dimensions are nominal

Device	Package Type	Package Drawing	Pins	SPQ	Reel Diameter (mm)	Reel Width W1 (mm)	A0 (mm)	B0 (mm)	K0 (mm)	P1 (mm)	W (mm)	Pin1 Quadrant
LM1894MX/NOPB	SOIC	D	14	2500	330.0	16.4	6.5	9.35	2.3	8.0	16.0	Q1

TAPE AND REEL BOX DIMENSIONS



*All dimensions are nominal



Device	Package Type	Package Drawing	Pins	SPQ	Length (mm)	Width (mm)	Height (mm)
LM1894MX/NOPB	SOIC	D	14	2500	367.0	367.0	35.0

D (R-PDSO-G14)

PLASTIC SMALL OUTLINE



4040047-5/M 06/11

- NOTES:
- A. All linear dimensions are in inches (millimeters).
 - B. This drawing is subject to change without notice.
 -  Body length does not include mold flash, protrusions, or gate burrs. Mold flash, protrusions, or gate burrs shall not exceed 0.006 (0,15) each side.
 -  Body width does not include interlead flash. Interlead flash shall not exceed 0.017 (0,43) each side.
 - E. Reference JEDEC MS-012 variation AB.

D (R-PDSO-G14)

PLASTIC SMALL OUTLINE



- NOTES:
- A. All linear dimensions are in millimeters.
 - B. This drawing is subject to change without notice.
 - C. Publication IPC-7351 is recommended for alternate designs.
 - D. Laser cutting apertures with trapezoidal walls and also rounding corners will offer better paste release. Customers should contact their board assembly site for stencil design recommendations. Refer to IPC-7525 for other stencil recommendations.
 - E. Customers should contact their board fabrication site for solder mask tolerances between and around signal pads.

IMPORTANT NOTICE AND DISCLAIMER

TI PROVIDES TECHNICAL AND RELIABILITY DATA (INCLUDING DATASHEETS), DESIGN RESOURCES (INCLUDING REFERENCE DESIGNS), APPLICATION OR OTHER DESIGN ADVICE, WEB TOOLS, SAFETY INFORMATION, AND OTHER RESOURCES "AS IS" AND WITH ALL FAULTS, AND DISCLAIMS ALL WARRANTIES, EXPRESS AND IMPLIED, INCLUDING WITHOUT LIMITATION ANY IMPLIED WARRANTIES OF MERCHANTABILITY, FITNESS FOR A PARTICULAR PURPOSE OR NON-INFRINGEMENT OF THIRD PARTY INTELLECTUAL PROPERTY RIGHTS.

These resources are intended for skilled developers designing with TI products. You are solely responsible for (1) selecting the appropriate TI products for your application, (2) designing, validating and testing your application, and (3) ensuring your application meets applicable standards, and any other safety, security, or other requirements. These resources are subject to change without notice. TI grants you permission to use these resources only for development of an application that uses the TI products described in the resource. Other reproduction and display of these resources is prohibited. No license is granted to any other TI intellectual property right or to any third party intellectual property right. TI disclaims responsibility for, and you will fully indemnify TI and its representatives against, any claims, damages, costs, losses, and liabilities arising out of your use of these resources.

TI's products are provided subject to TI's Terms of Sale (www.ti.com/legal/termsofsale.html) or other applicable terms available either on ti.com or provided in conjunction with such TI products. TI's provision of these resources does not expand or otherwise alter TI's applicable warranties or warranty disclaimers for TI products.

Mailing Address: Texas Instruments, Post Office Box 655303, Dallas, Texas 75265
Copyright © 2020, Texas Instruments Incorporated