

具有双集成比较器的 **INA30x 36V**、过流保护、精密、 电流监测放大器

1 特性

- 宽共模输入范围：-0.1V 至 +36V
- 双比较器输出：
 - **INA302**：两个独立的超限警报
 - **INA303**：窗口比较器
 - 阈值电平单独设置
 - 比较器 1 警报响应：1 μ s
 - 比较器 2 可调延迟：2 μ s 至 10s
 - 具有独立锁存控制模式的开漏极输出
- 高精度放大器：
 - 失调电压：30 μ V（最大值，A3 版本）
 - 失调电压漂移：0.5 μ V/ $^{\circ}$ C（最大值）
 - 增益误差：0.15%（最大值，A3 版本）
 - 增益误差漂移：10ppm/ $^{\circ}$ C
- 可用放大器增益：
 - **INA302A1**、**INA303A1**：20V/V
 - **INA302A2**、**INA303A2**：50V/V
 - **INA302A3**、**INA303A3**：100V/V

2 应用

- 过流保护
- 电机控制
- 电源保护
- 计算机和服务器
- 电信设备

3 说明

INA302 和 **INA303** (**INA30x**) 器件具有一个高共模、双向、电流检测放大器和两个高速比较器，用于检测超出范围的电流状况。**INA302** 比较器配置为检测和响应过流状况。**INA303** 比较器在窗口配置中配置为响应过流和欠流状况。这些器件使用外部限位设置电阻器，对每个比较器设置都具有可调限位阈值范围。这些电流分流监控器可在独立于电源的 -0.1V 至 36V 共模电压范围内测量差动电压信号。

开漏极警报输出可配置为在透明模式（输出状态与输入状态保持一致）或锁存模式（警报输出在锁存复位时清除）下运行。比较器 1 的警报响应时间小于 1 μ s，而比较器 2 的警报响应时间通过外部电容器进行设置，范围介于 2 μ s 至 10s 之间。

这些器件由单个 2.7V 至 5.5V 电源供电，消耗的最大电源电流为 950 μ A。这些器件具有 -40 $^{\circ}$ C 至 +125 $^{\circ}$ C 的扩展额定工作温度范围，并且采用 14 引脚 TSSOP 封装。

器件信息

器件型号	封装	封装尺寸（标称值）
INA302	TSSOP (14)	4.40mm x 5.00mm
INA303		

(1) 如需了解所有可用封装，请参阅数据表末尾的封装选项附录。

典型应用

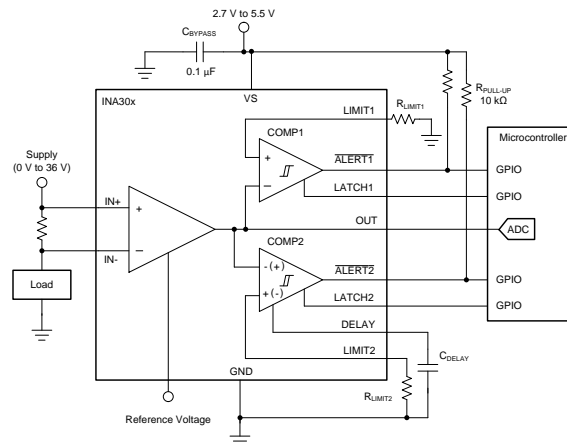

目录

<p>1 特性 1</p> <p>2 应用 1</p> <p>3 说明 1</p> <p>4 修订历史记录 2</p> <p>5 Pin Configuration and Functions 3</p> <p>6 Specifications 4</p> <p> 6.1 Absolute Maximum Ratings 4</p> <p> 6.2 ESD Ratings 4</p> <p> 6.3 Recommended Operating Conditions 4</p> <p> 6.4 Thermal Information 4</p> <p> 6.5 Electrical Characteristics 5</p> <p> 6.6 Typical Characteristics 7</p> <p>7 Detailed Description 14</p> <p> 7.1 Overview 14</p> <p> 7.2 Functional Block Diagram 14</p> <p> 7.3 Feature Description 15</p> <p> 7.4 Device Functional Modes 21</p>	<p>8 Application and Implementation 23</p> <p> 8.1 Application Information 23</p> <p> 8.2 Typical Application 29</p> <p>9 Power Supply Recommendations 31</p> <p>10 Layout 31</p> <p> 10.1 Layout Guidelines 31</p> <p> 10.2 Layout Example 32</p> <p>11 器件和文档支持 33</p> <p> 11.1 文档支持 33</p> <p> 11.2 相关链接 33</p> <p> 11.3 接收文档更新通知 33</p> <p> 11.4 社区资源 33</p> <p> 11.5 商标 33</p> <p> 11.6 静电放电警告 33</p> <p> 11.7 术语表 33</p> <p>12 机械、封装和可订购信息 33</p>
---	--

4 修订历史记录

注：之前版本的页码可能与当前版本有所不同。

Changes from Revision B (April 2017) to Revision C	Page
• 已更改 更改了一些部分的位置和文本，使之更清晰；无内容更改 1	1
• Added MIN and MAX values to V_{CM} and V_S rows of <i>Recommended Operating Conditions</i> table 4	4
• Deleted V_{CM} , V_S , and temperature range rows from <i>Electrical Characteristics</i> table; same content listed in <i>Recommended Operating Conditions</i> table 5	5

Changes from Revision A (February 2017) to Revision B	Page
• 已更改 y-axis units from 0.5 V/div to 1 V/div and changed (INA30xA1) to (INA30x) in title of <i>Comparator 1 Total Propagation Delay</i> figure 12	12
• 已更改 y-axis units from 0.5 V/div to 1 V/div and changed (INA303A1) to (INA303) in title of <i>Comparator 2 Total Propagation Delay</i> figure 12	12
• 已删除 <i>Comparator 1 Total Propagation Delay (INA30xA2)</i> , <i>Comparator 1 Total Propagation Delay (INA30xA3)</i> , <i>Comparator 2 Total Propagation Delay (INA303A2)</i> , and <i>Comparator 2 Total Propagation Delay (INA303A3)</i> figures 12	12
• 已更改 (INA303A1) to (INA303) in title of <i>Comparator 2 Total Propagation Delay</i> figure 12	12
• 已删除 <i>Comparator 2 Total Propagation Delay (INA303A2)</i> and <i>Comparator 2 Total Propagation Delay (INA303A3)</i> figures 12	12
• 已添加 <i>Comparator 2 Total Propagation Delay (INA302A1)</i> and <i>Comparator 2 Total Propagation Delay (INA302A1)</i> figures 12	12

Changes from Original (September 2016) to Revision A	Page
• 将已发布更改为生产 1	1

5 Pin Configuration and Functions

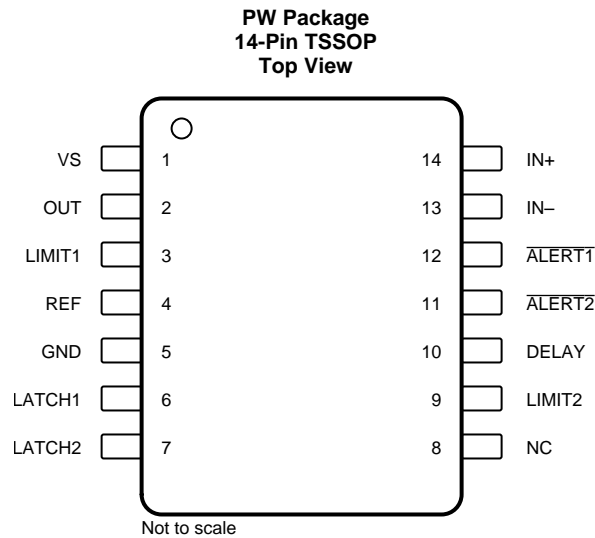

Pin Functions

PIN		TYPE	DESCRIPTION
NO.	NAME		
1	VS	Analog	Power supply, 2.7 V to 5.5 V
2	OUT	Analog output	Output voltage
3	LIMIT1	Analog input	$\overline{\text{ALERT1}}$ threshold limit input; see the Setting Alert Thresholds section for details on setting the limit threshold
4	REF	Analog input	Reference voltage, 0 V to VS
5	GND	Analog	Ground
6	LATCH1	Digital input	Transparent or latch mode selection input
7	LATCH2	Digital input	Transparent or latch mode selection input
8	NC	—	No internal connection
9	LIMIT2	Analog input	$\overline{\text{ALERT2}}$ threshold limit input; see the Setting Alert Thresholds section for details on setting the limit threshold
10	DELAY	Analog input	Delay timing input; see the Alert Outputs section for details on setting the delayed alert response for comparator 2
11	$\overline{\text{ALERT2}}$	Analog output	Open-drain output; active-low. This pin is an overlimit alert for the INA302 and an underlimit alert for the INA303.
12	$\overline{\text{ALERT1}}$	Analog output	Open-drain output, active-low overlimit alert
13	IN-	Analog input	Connect to load side of the current-sensing resistor
14	IN+	Analog input	Connect to supply side of the current-sensing resistor

6 Specifications

6.1 Absolute Maximum Ratings

over operating free-air temperature range (unless otherwise noted)⁽¹⁾

		MIN	MAX	UNIT	
V _S	Supply voltage		6	V	
	Analog inputs (IN+, IN–)	Differential (V _{IN+} – V _{IN–}) ⁽²⁾	–40	40	V
		Common-mode ⁽³⁾	GND – 0.3	40	
	Analog input	LIMIT1, LIMIT2, DELAY, REF	GND – 0.3	(V _S) + 0.3	V
	Analog output	OUT	GND – 0.3	(V _S) + 0.3	V
	Digital input	LATCH1, LATCH2	GND – 0.3	(V _S) + 0.3	V
	Digital output	$\overline{\text{ALERT1}}$, $\overline{\text{ALERT2}}$	GND – 0.3	6	V
T _J	Junction temperature		150	°C	
T _{stg}	Storage temperature	–65	150	°C	

- (1) Stresses beyond those listed under *Absolute Maximum Ratings* may cause permanent damage to the device. These are stress ratings only, which do not imply functional operation of the device at these or any other conditions beyond those indicated under *Recommended Operating Conditions*. Exposure to absolute-maximum-rated conditions for extended periods may affect device reliability.
- (2) V_{IN+} and V_{IN–} are the voltages at the IN+ and IN– pins, respectively.
- (3) Input voltage can exceed the voltage shown without causing damage to the device if the current at that pin is limited to 5 mA.

6.2 ESD Ratings

		VALUE	UNIT	
V _(ESD)	Electrostatic discharge	Human-body model (HBM), per ANSI/ESDA/JEDEC JS-001 ⁽¹⁾	±3000	V
		Charged-device model (CDM), per JEDEC specification JESD22-C101 ⁽²⁾	±1500	

- (1) JEDEC document JEP155 states that 500-V HBM allows safe manufacturing with a standard ESD control process.
- (2) JEDEC document JEP157 states that 250-V CDM allows safe manufacturing with a standard ESD control process.

6.3 Recommended Operating Conditions

over operating free-air temperature range (unless otherwise noted)

		MIN	NOM	MAX	UNIT
V _{CM}	Common-mode input voltage	–0.1	12	36	V
V _S	Operating supply voltage	2.7	5	5.5	V
T _A	Operating free-air temperature	–40		125	°C

6.4 Thermal Information

THERMAL METRIC ⁽¹⁾		INA30x	UNIT
		PW (TSSOP)	
		14 PINS	
R _{θJA}	Junction-to-ambient thermal resistance	110.2	°C/W
R _{θJC(top)}	Junction-to-case (top) thermal resistance	35.1	°C/W
R _{θJB}	Junction-to-board thermal resistance	53.2	°C/W
ψ _{JT}	Junction-to-top characterization parameter	2.3	°C/W
ψ _{JB}	Junction-to-board characterization parameter	52.4	°C/W
R _{θJC(bot)}	Junction-to-case (bottom) thermal resistance	N/A	°C/W

- (1) For more information about traditional and new thermal metrics, see the [Semiconductor and IC Package Thermal Metrics application report](#).

6.5 Electrical Characteristics

at $T_A = 25^\circ\text{C}$, $V_{\text{SENSE}} = 0\text{ V}$, $V_{\text{REF}} = V_S / 2$, $V_S = 5\text{ V}$, $V_{\text{IN}+} = 12\text{ V}$, $V_{\text{LIMIT}1} = 3\text{ V}$, and $V_{\text{LIMIT}2} = 3\text{ V}$ (INA302) or 2 V (INA303) (unless otherwise noted)

PARAMETER		TEST CONDITIONS	MIN	TYP	MAX	UNIT
INPUT						
V_{IN}	Differential input voltage range	$V_{\text{IN}} = V_{\text{IN}+} - V_{\text{IN}-}$, $V_{\text{REF}} = V_S / 2$, A1 versions	0		± 125	mV
		$V_{\text{IN}} = V_{\text{IN}+} - V_{\text{IN}-}$, $V_{\text{REF}} = V_S / 2$, A2 versions	0		± 50	
		$V_{\text{IN}} = V_{\text{IN}+} - V_{\text{IN}-}$, $V_{\text{REF}} = V_S / 2$, A3 versions	0		± 25	
CMRR	Common-mode rejection ratio	$V_{\text{IN}+} = 0\text{ V to } 36\text{ V}$, $T_A = -40^\circ\text{C to } +125^\circ\text{C}$, A1 versions	100	114		dB
		$V_{\text{IN}+} = 0\text{ V to } 36\text{ V}$, $T_A = -40^\circ\text{C to } +125^\circ\text{C}$, A2 versions	106	118		
		$V_{\text{IN}+} = 0\text{ V to } 36\text{ V}$, $T_A = -40^\circ\text{C to } +125^\circ\text{C}$, A3 versions	110	120		
V_{OS}	Offset voltage, RTI ⁽¹⁾	A1 versions		± 15	± 80	μV
		A2 versions		± 10	± 50	
		A3 versions		± 5	± 30	
dV_{OS}/dT	Offset voltage drift, RTI ⁽¹⁾	$T_A = -40^\circ\text{C to } +125^\circ\text{C}$		0.02	0.25	$\mu\text{V}/^\circ\text{C}$
PSRR	Power-supply rejection ratio	$V_S = 2.7\text{ V to } 5.5\text{ V}$, $V_{\text{IN}+} = 12\text{ V}$, $T_A = -40^\circ\text{C to } +125^\circ\text{C}$		± 0.3	± 5	$\mu\text{V}/\text{V}$
I_B	Input bias current	I_{B+} , I_{B-}		115		μA
I_{OS}	Input offset current	$V_{\text{SENSE}} = 0\text{ mV}$		± 0.01		μA
OUTPUT						
G	Gain	A1 versions		20		V/V
		A2 versions		50		
		A3 versions		100		
	Gain error	$V_{\text{OUT}} = 0.5\text{ V to } V_S - 0.5\text{ V}$, A1 versions		$\pm 0.02\%$	$\pm 0.075\%$	
		$V_{\text{OUT}} = 0.5\text{ V to } V_S - 0.5\text{ V}$, A2 versions		$\pm 0.05\%$	$\pm 0.1\%$	
		$V_{\text{OUT}} = 0.5\text{ V to } V_S - 0.5\text{ V}$, A3 versions		$\pm 0.1\%$	$\pm 0.15\%$	
		$T_A = -40^\circ\text{C to } +125^\circ\text{C}$		3	10	
	Nonlinearity error	$V_{\text{OUT}} = 0.5\text{ V to } V_S - 0.5\text{ V}$		$\pm 0.01\%$		
	Maximum capacitive load	No sustained oscillation		500		pF
VOLTAGE OUTPUT						
	Swing to V_S power-supply rail	$R_L = 10\text{ k}\Omega$ to GND, $T_A = -40^\circ\text{C to } +125^\circ\text{C}$		$V_S - 0.05$	$V_S - 0.1$	V
	Swing to GND	$R_L = 10\text{ k}\Omega$ to GND, $T_A = -40^\circ\text{C to } +125^\circ\text{C}$		$V_{\text{GND}} + 15$	$V_{\text{GND}} + 30$	mV
FREQUENCY RESPONSE						
BW	Bandwidth	A1 versions, $C_{\text{OUT}} = 500\text{ pF}$		550		kHz
		A2 versions, $C_{\text{OUT}} = 500\text{ pF}$		440		
		A3 versions, $C_{\text{OUT}} = 500\text{ pF}$		400		
SR	Slew rate			4		V/ μs
NOISE, RTI⁽¹⁾						
	Voltage noise density			30		nV/ $\sqrt{\text{Hz}}$

(1) RTI = referred-to-input.

Electrical Characteristics (continued)

 at $T_A = 25^\circ\text{C}$, $V_{\text{SENSE}} = 0\text{ V}$, $V_{\text{REF}} = V_S / 2$, $V_S = 5\text{ V}$, $V_{\text{IN}+} = 12\text{ V}$, $V_{\text{LIMIT}1} = 3\text{ V}$, and $V_{\text{LIMIT}2} = 3\text{ V}$ (INA302) or 2 V (INA303) (unless otherwise noted)

PARAMETER		TEST CONDITIONS	MIN	TYP	MAX	UNIT
COMPARATOR						
t_p	Total alert propagation delay	Comparator 1, input overdrive = 1 mV		0.6	1	μs
		Comparator 2, input overdrive = 1 mV, delay = 100 k Ω to V_S		1.25	2	
	Slew-rate-limited t_p	Comparator 1, V_{OUT} step = 0.5 V to 4.5 V, $V_{\text{LIMIT}} = 4\text{ V}$		1	1.5	μs
		Comparator 2 (INA302), V_{OUT} step = 0.5 V to 4.5 V, $V_{\text{LIMIT}} = 4\text{ V}$, delay = 100 k Ω to V_S		1.5	2.5	
		Comparator 2 (INA303), V_{OUT} step = 4.5 V to 0.5 V, $V_{\text{LIMIT}} = 1\text{ V}$, delay = 100 k Ω to V_S		1.5	2.5	
$I_{\text{LIMIT}1}$	Limit threshold output current, comparator 1	$T_A = 25^\circ\text{C}$, $V_{\text{LIMIT}1} < V_S - 0.6\text{ V}$	79.2	80	80.8	μA
		$T_A = -40^\circ\text{C}$ to $+125^\circ\text{C}$, $V_{\text{LIMIT}1} < V_S - 0.6\text{ V}$	78.4		81.6	
$I_{\text{LIMIT}2}$	Limit threshold output current, comparator 2	$T_A = 25^\circ\text{C}$, $V_{\text{LIMIT}2} < V_S - 0.6\text{ V}$	79.7	80	80.4	μA
		$T_A = -40^\circ\text{C}$ to $+125^\circ\text{C}$, $V_{\text{LIMIT}2} < V_S - 0.6\text{ V}$	79.2		80.8	
V_{OS}	Offset voltage, both comparators	A1 versions		0.5	3.5	mV
		A2 versions		0.5	3.5	
		A3 versions		0.5	4.0	
HYS	Hysteresis	comparator 1, comparator 2		100		mV
	Internal programmable delay error	$T_A = -40^\circ\text{C}$ to $+125^\circ\text{C}$			4%	
V_{TH}	Delay threshold voltage	$T_A = -40^\circ\text{C}$ to $+125^\circ\text{C}$	1.21	1.22	1.23	V
I_{D}	Delay charging current	$T_A = -40^\circ\text{C}$ to $+125^\circ\text{C}$, $V_{\text{DELAY}} = 0.6\text{ V}$	4.85	5	5.15	μA
R_{D}	Delay discharge resistance			70		Ω
V_{IH}	LATCH1, LATCH2 high-level input voltage	$T_A = -40^\circ\text{C}$ to $+125^\circ\text{C}$	1.4		6	V
V_{IL}	LATCH1, LATCH2 low-level input voltage	$T_A = -40^\circ\text{C}$ to $+125^\circ\text{C}$	0		0.4	V
V_{OL}	Alert low-level output voltage	$I_{\text{OL}} = 3\text{ mA}$, $T_A = -40^\circ\text{C}$ to $+125^\circ\text{C}$		70	400	mV
	$\overline{\text{ALERT}1}$, $\overline{\text{ALERT}2}$ pin leakage input current	$V_{\text{OH}} = 3.3\text{ V}$		0.1	1	μA
	LATCH1, LATCH2 digital leakage input current	$0\text{ V} \leq V_{\text{LATCH}1}, V_{\text{LATCH}2} \leq V_S$		1		μA
POWER SUPPLY						
I_{Q}	Quiescent current	$T_A = 25^\circ\text{C}$		850	950	μA
		$T_A = -40^\circ\text{C}$ to $+125^\circ\text{C}$			1150	

6.6 Typical Characteristics

at $T_A = 25^\circ\text{C}$, $V_{REF} = V_S / 2$, $V_{SENSE} = 0\text{ V}$, $V_S = 5\text{ V}$, $V_{IN+} = 12\text{ V}$, and $\overline{\text{ALERT1}}$, $\overline{\text{ALERT2}}$ pullup resistors = $10\text{ k}\Omega$ (unless otherwise noted)



图 1. Input Offset Voltage Distribution (INA30xA1)



图 2. Input Offset Voltage Distribution (INA30xA2)

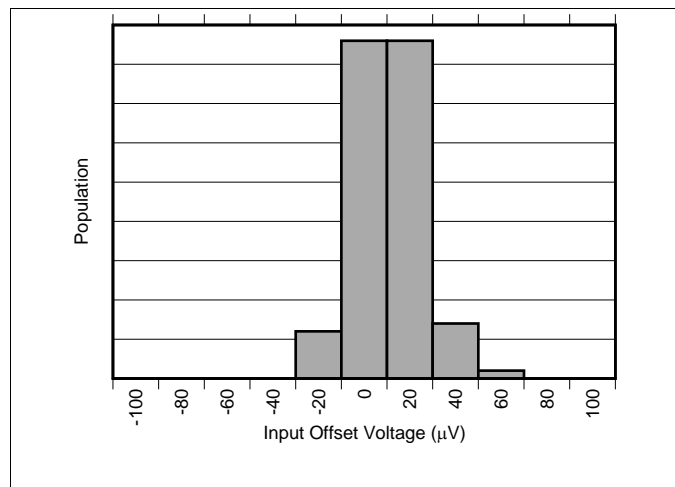

图 3. Input Offset Voltage Distribution (INA30xA3)

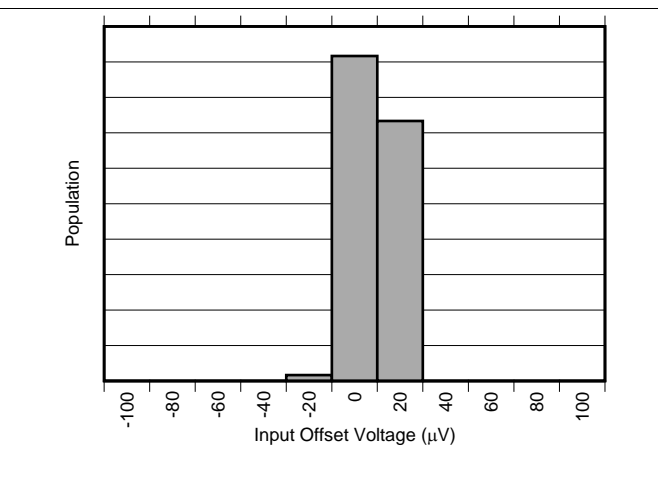

图 4. Input Offset Voltage vs Temperature

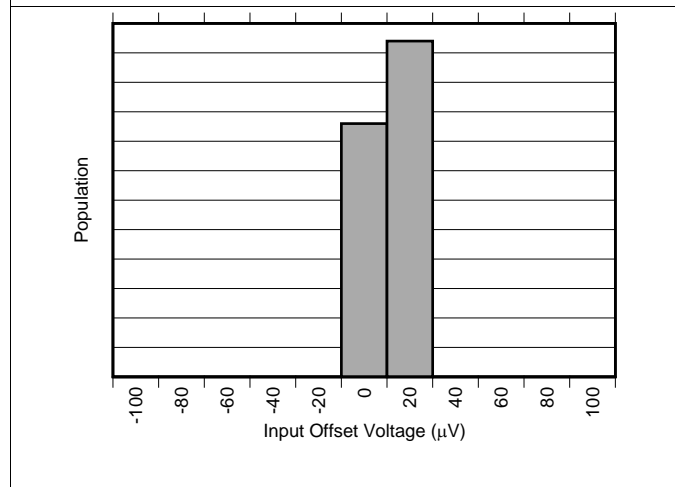

图 5. CMRR Distribution (INA30xA1)

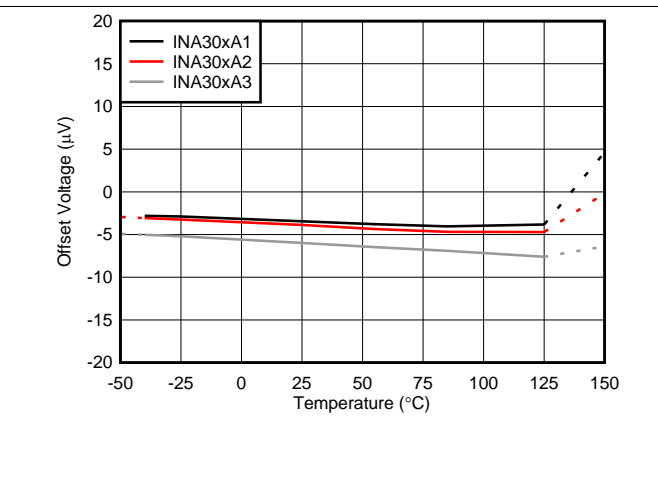

图 6. CMRR Distribution (INA30xA2)

Typical Characteristics (接下页)

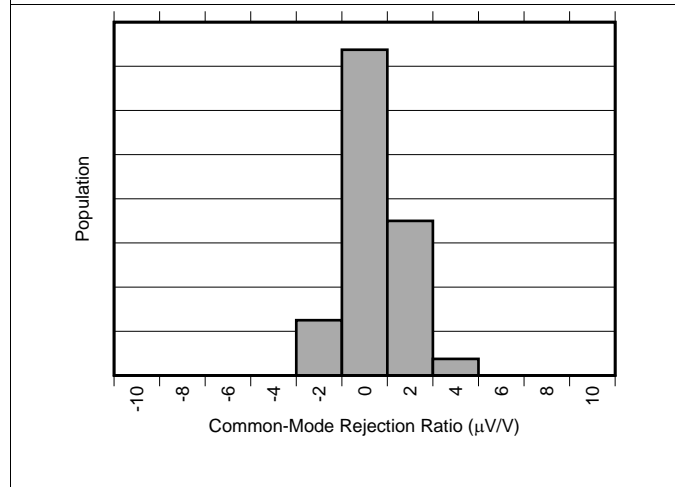
at $T_A = 25^\circ\text{C}$, $V_{REF} = V_S / 2$, $V_{SENSE} = 0\text{ V}$, $V_S = 5\text{ V}$, $V_{IN+} = 12\text{ V}$, and $\overline{ALERT1}$, $\overline{ALERT2}$ pullup resistors = $10\text{ k}\Omega$ (unless otherwise noted)

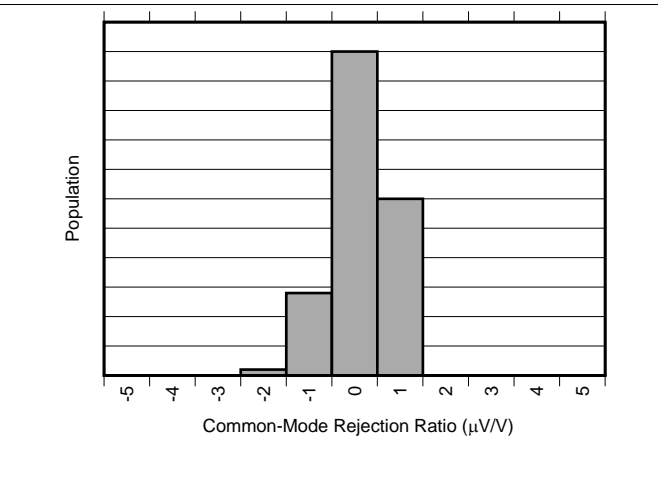

图 7. CMRR Distribution (INA30xA3)



图 8. CMRR vs Temperature

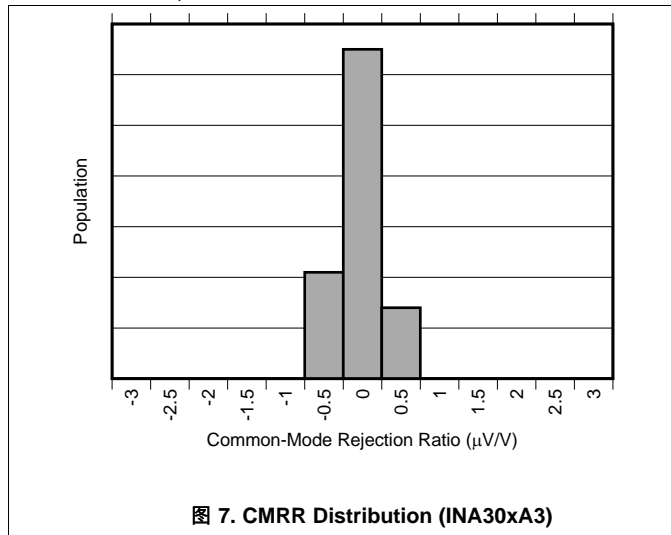

图 9. CMRR vs Frequency

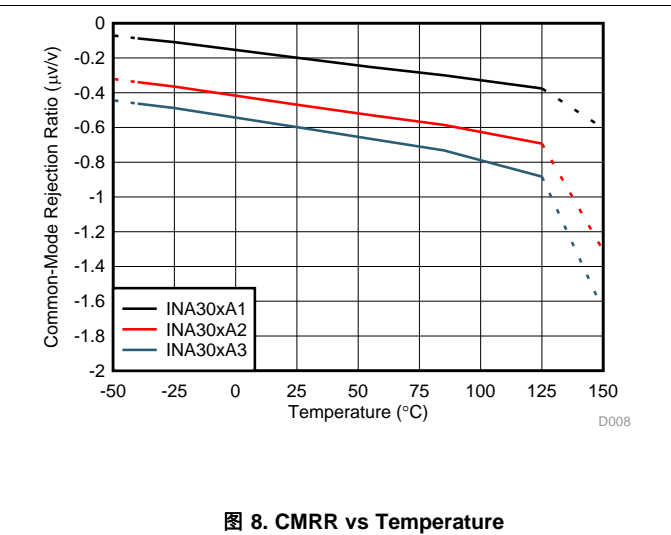

图 10. Gain Error Distribution (INA30xA1)

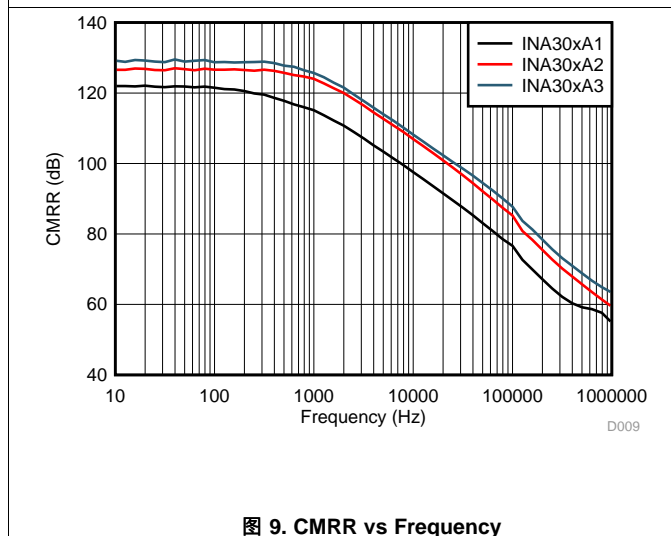

图 11. Gain Error Distribution (INA30xA2)

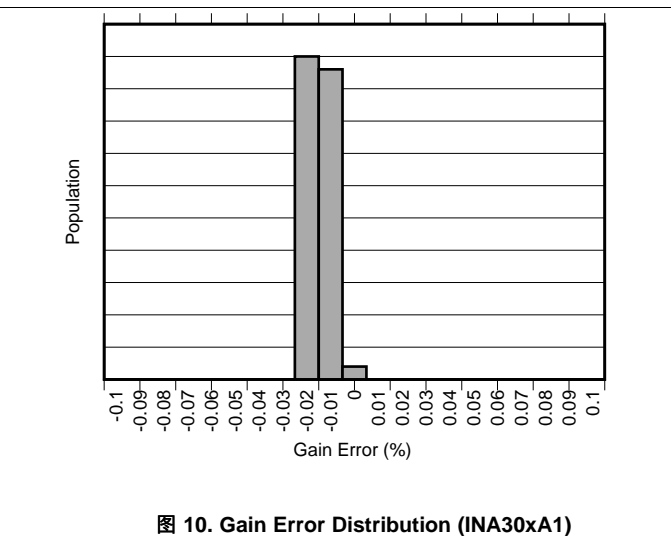

图 12. Gain Error Distribution (INA30xA3)

Typical Characteristics (接下页)

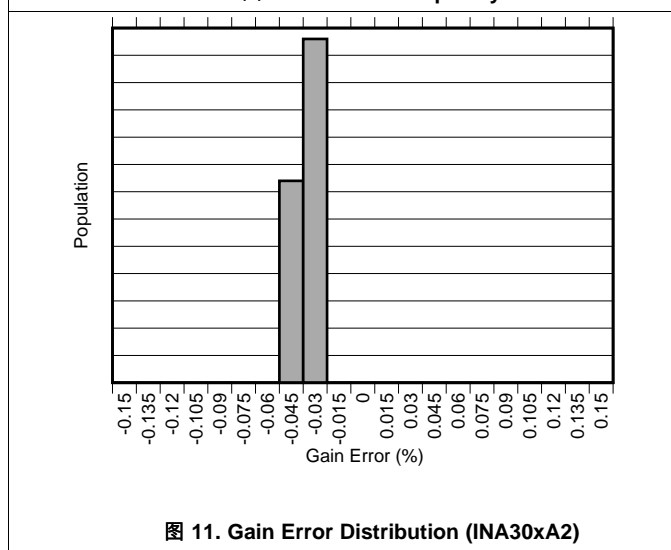
at $T_A = 25^\circ\text{C}$, $V_{REF} = V_S / 2$, $V_{SENSE} = 0\text{ V}$, $V_S = 5\text{ V}$, $V_{IN+} = 12\text{ V}$, and $\overline{\text{ALERT1}}$, $\overline{\text{ALERT2}}$ pullup resistors = $10\text{ k}\Omega$ (unless otherwise noted)

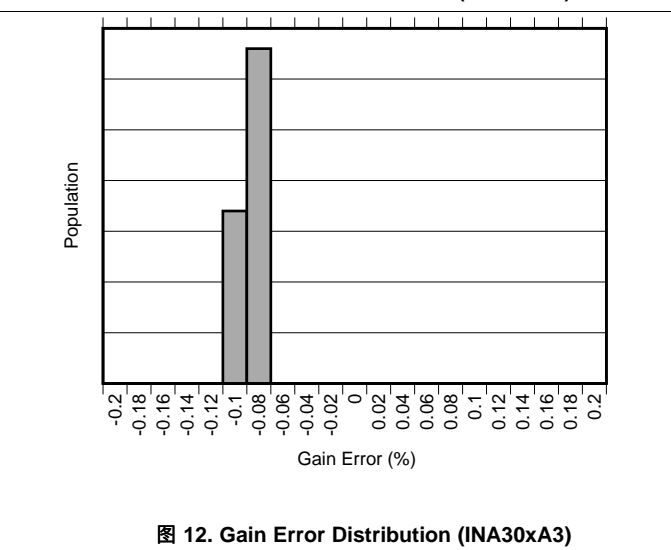

图 13. Gain Error vs Temperature



图 14. Gain vs Frequency

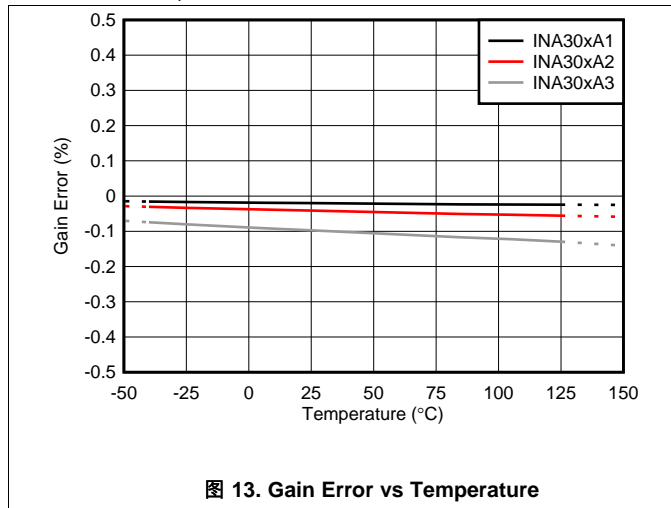

图 15. PSRR vs Frequency

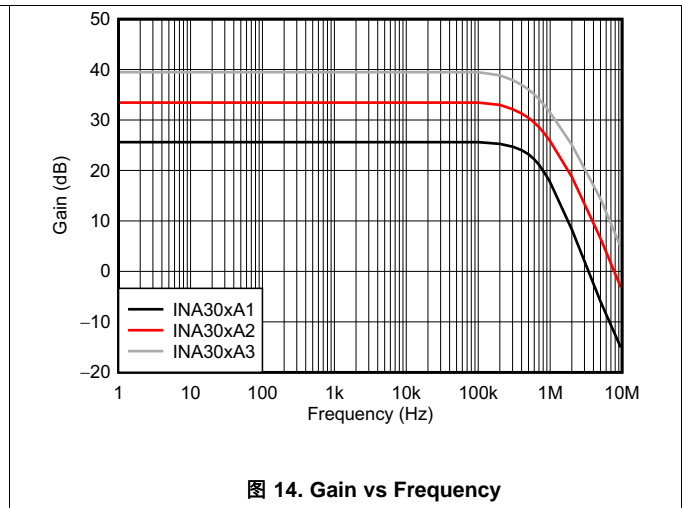

图 16. Output Voltage Swing vs Output Current

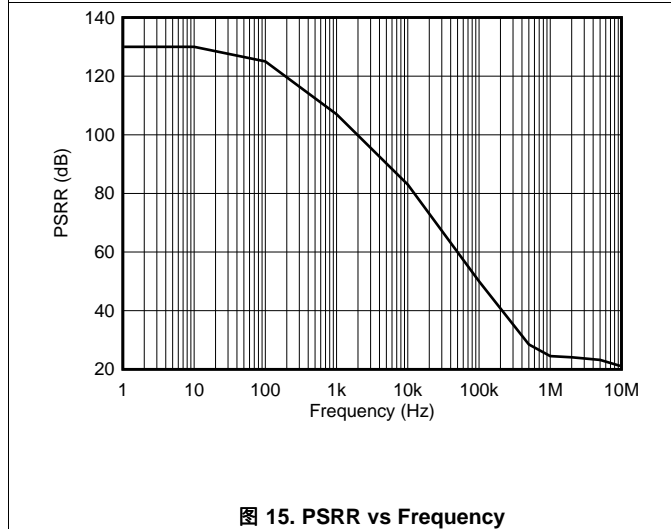

图 17. Input Bias Current vs Common-Mode Voltage

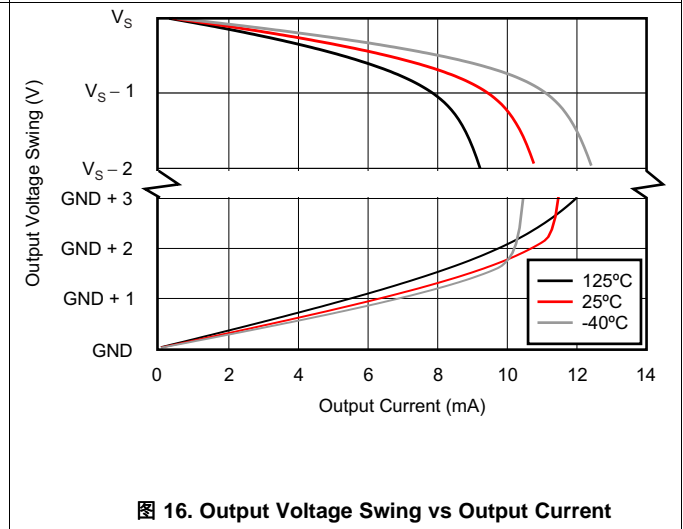

图 18. Input Bias Current vs Common-Mode Voltage

Typical Characteristics (接下页)

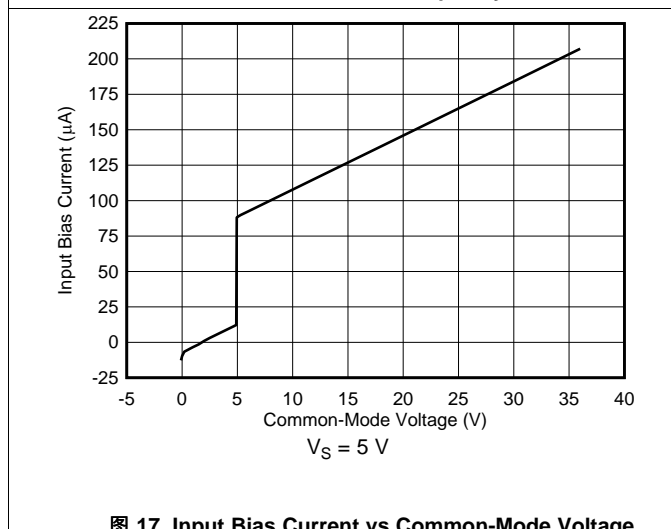
at $T_A = 25^\circ\text{C}$, $V_{REF} = V_S / 2$, $V_{SENSE} = 0\text{ V}$, $V_S = 5\text{ V}$, $V_{IN+} = 12\text{ V}$, and $\overline{\text{ALERT1}}$, $\overline{\text{ALERT2}}$ pullup resistors = $10\text{ k}\Omega$ (unless otherwise noted)

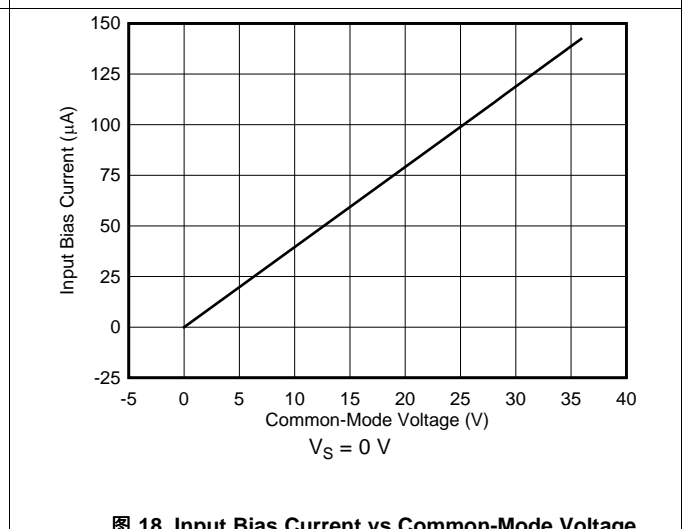

图 19. Input Bias Current vs Temperature



图 20. Quiescent Current vs Supply Voltage

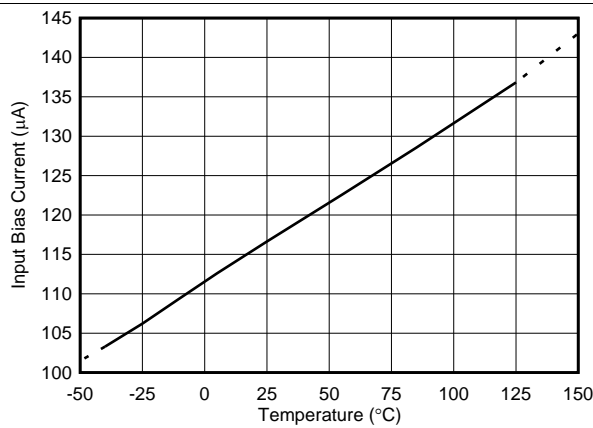

图 21. Quiescent Current vs Temperature

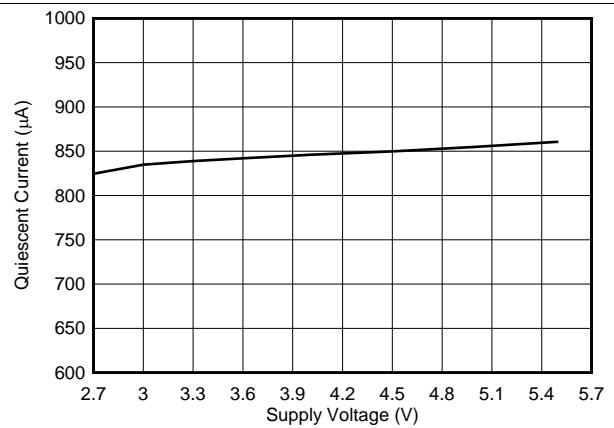

图 22. Input-Referred Voltage Noise vs Frequency

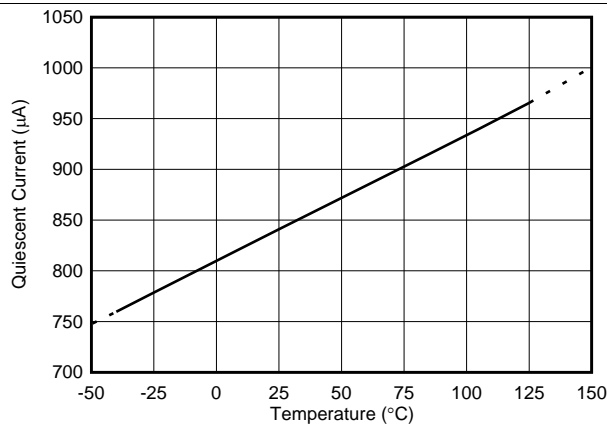

图 23. 0.1-Hz to 10-Hz Voltage Noise (Referred to Input)

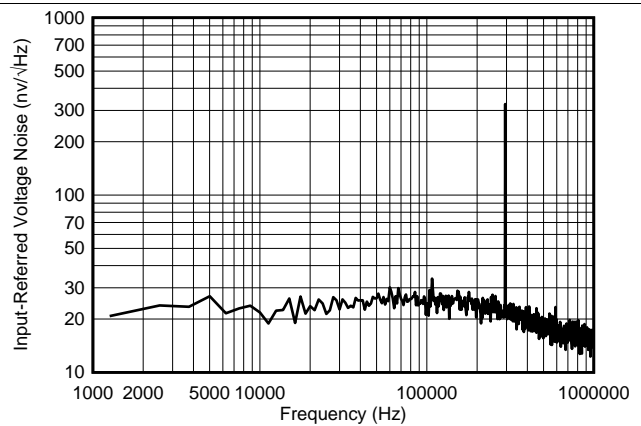

图 24. Voltage Output Rising Step Response

Typical Characteristics (接下页)

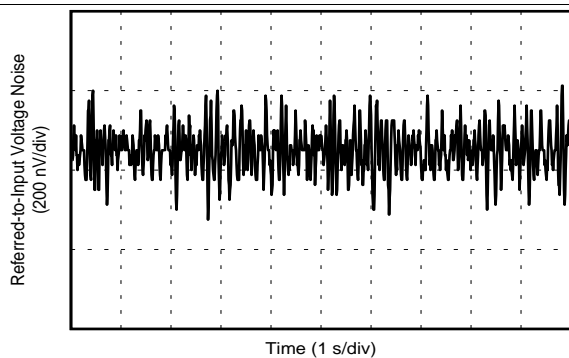
at $T_A = 25^\circ\text{C}$, $V_{REF} = V_S / 2$, $V_{SENSE} = 0\text{ V}$, $V_S = 5\text{ V}$, $V_{IN+} = 12\text{ V}$, and $\overline{\text{ALERT1}}$, $\overline{\text{ALERT2}}$ pullup resistors = $10\text{ k}\Omega$ (unless otherwise noted)

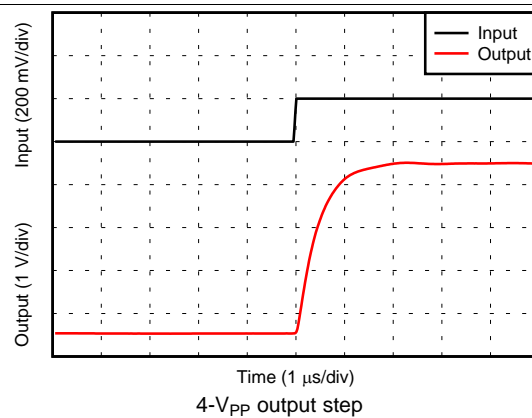
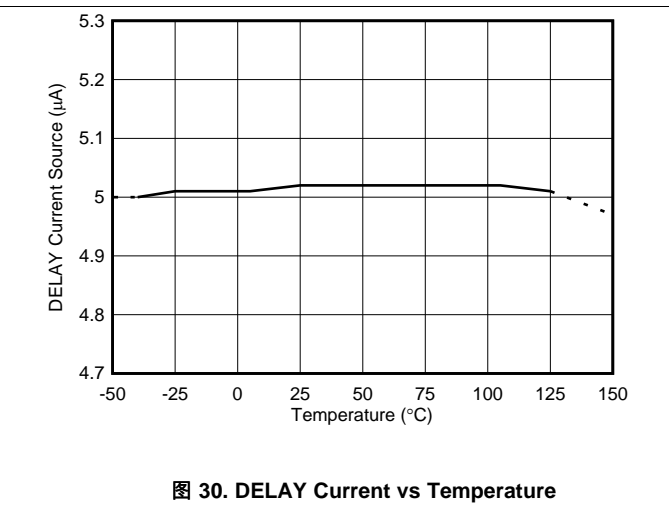
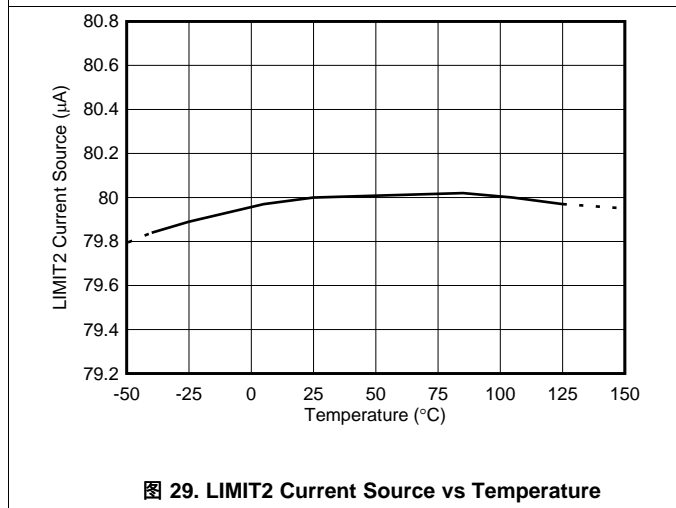
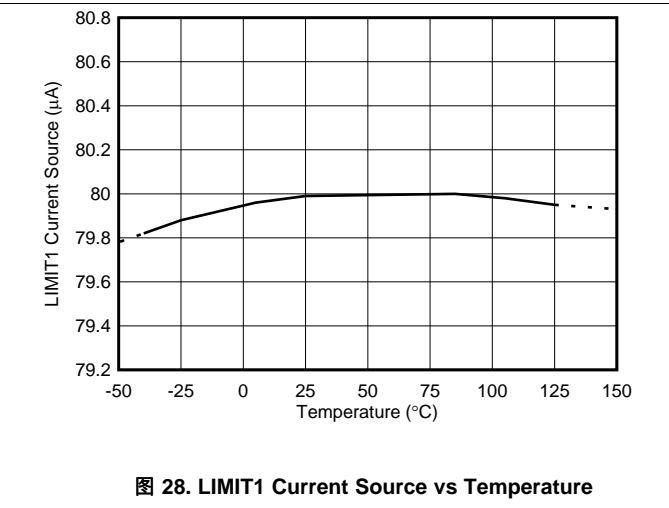
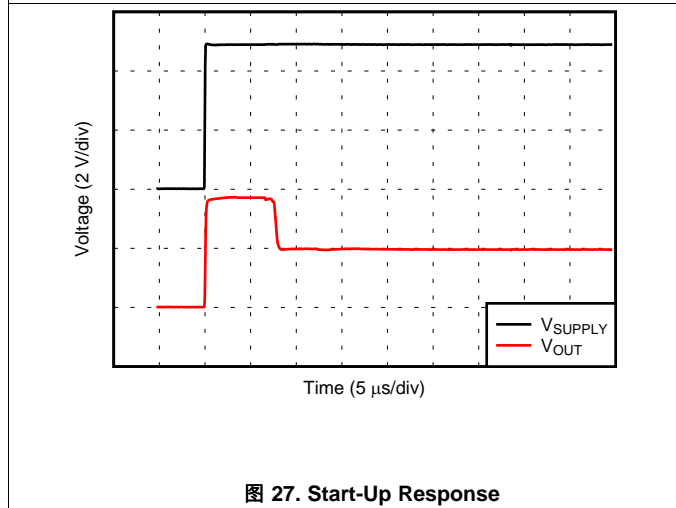
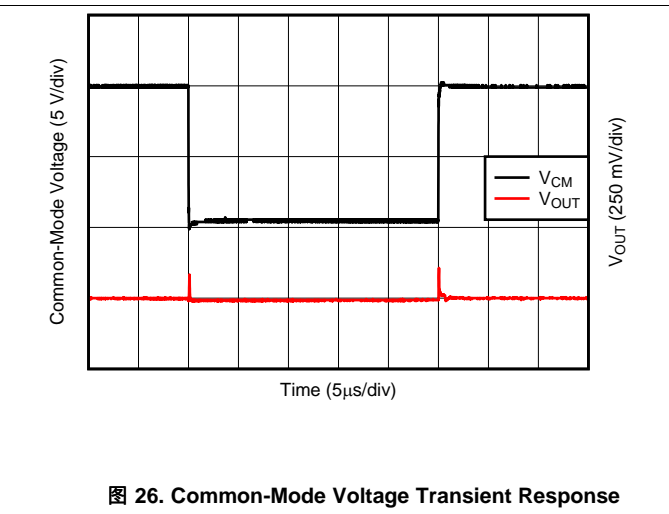
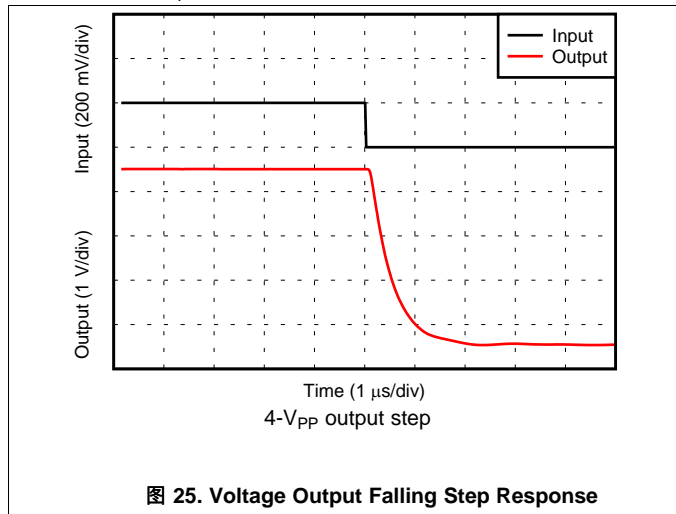

Typical Characteristics (接下页)

at $T_A = 25^\circ\text{C}$, $V_{REF} = V_S / 2$, $V_{SENSE} = 0\text{ V}$, $V_S = 5\text{ V}$, $V_{IN+} = 12\text{ V}$, and $\overline{\text{ALERT1}}$, $\overline{\text{ALERT2}}$ pullup resistors = $10\text{ k}\Omega$ (unless otherwise noted)

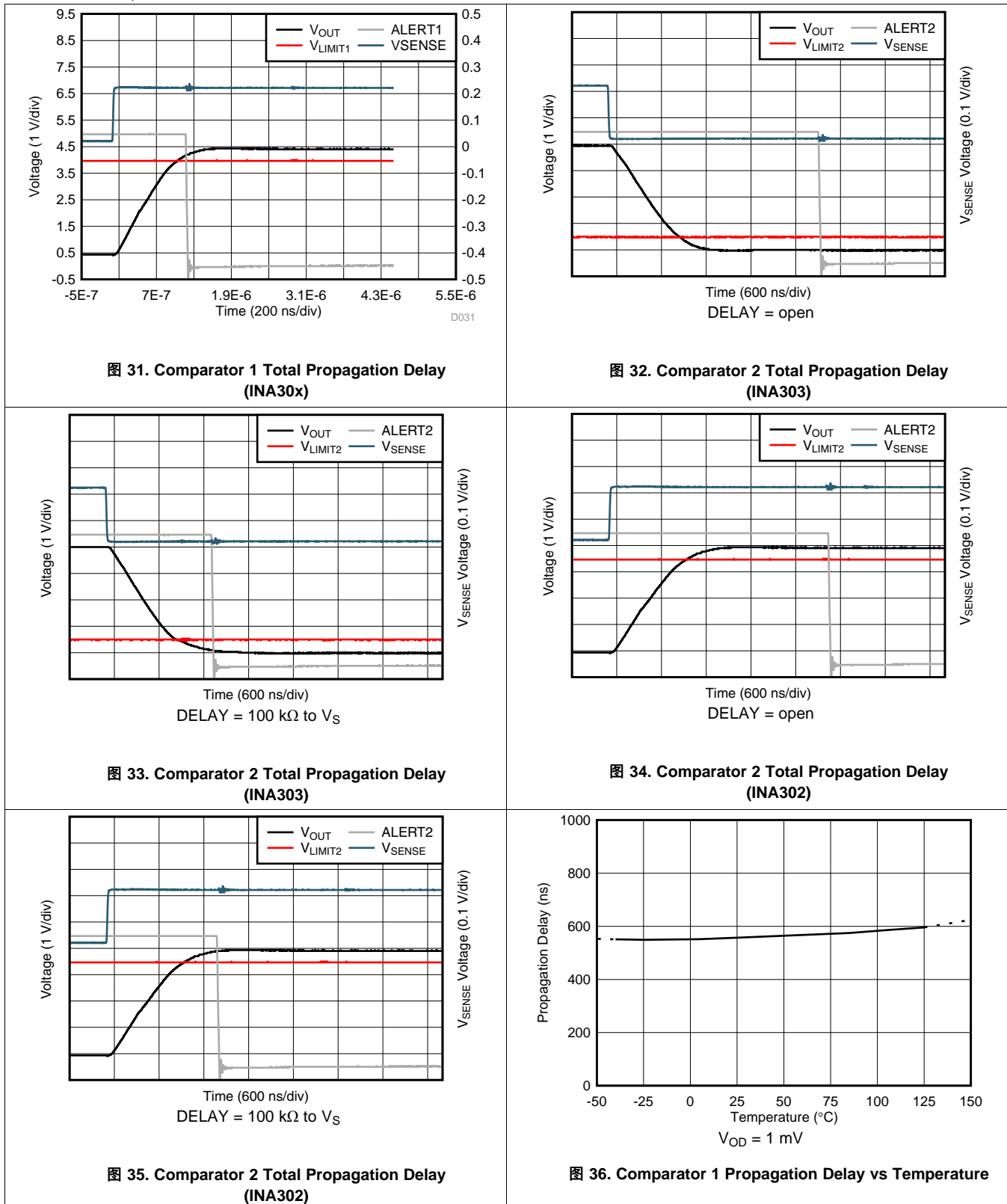

Typical Characteristics (接下页)

at $T_A = 25^\circ\text{C}$, $V_{REF} = V_S / 2$, $V_{SENSE} = 0\text{ V}$, $V_S = 5\text{ V}$, $V_{IN+} = 12\text{ V}$, and $\overline{\text{ALERT1}}$, $\overline{\text{ALERT2}}$ pullup resistors = $10\text{ k}\Omega$ (unless otherwise noted)



图 37. Comparator 2 Propagation Delay vs Temperature



图 38. Comparator Alert V_{OL} vs I_{OL}

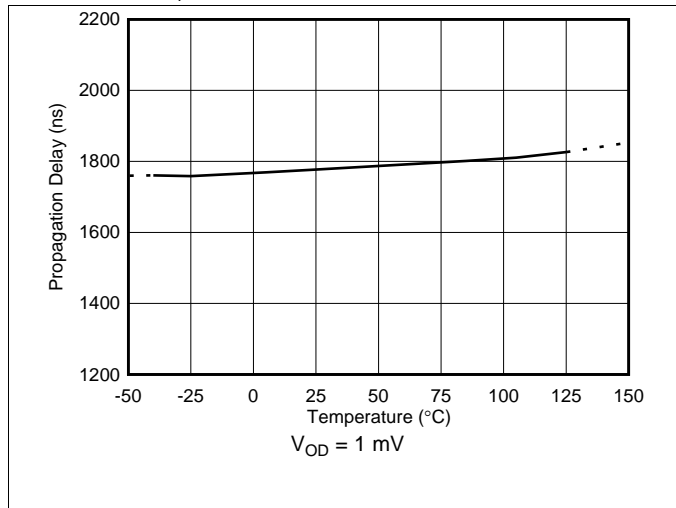

图 39. Comparator 1 Hysteresis vs Temperature

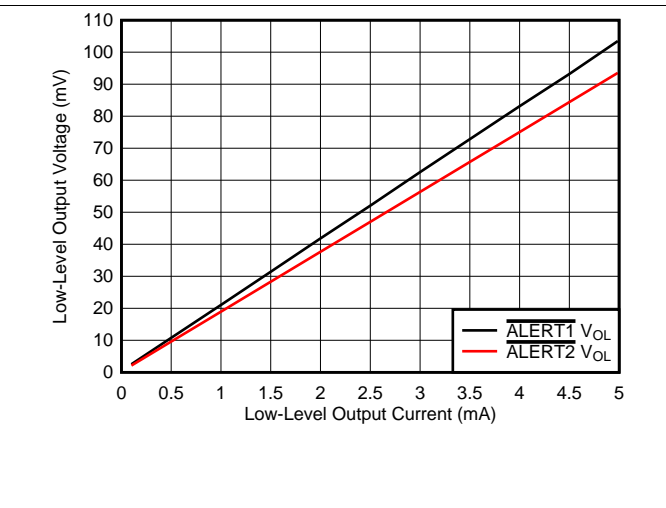

图 40. Comparator 2 Hysteresis vs Temperature

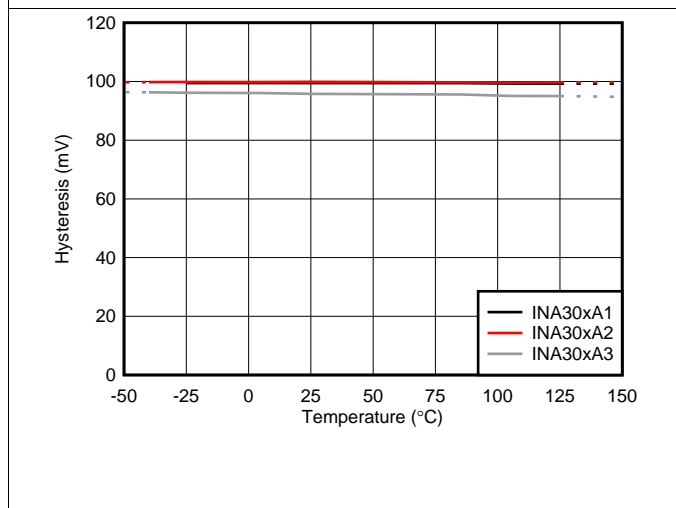

图 41. Comparator Latch Response

7 Detailed Description

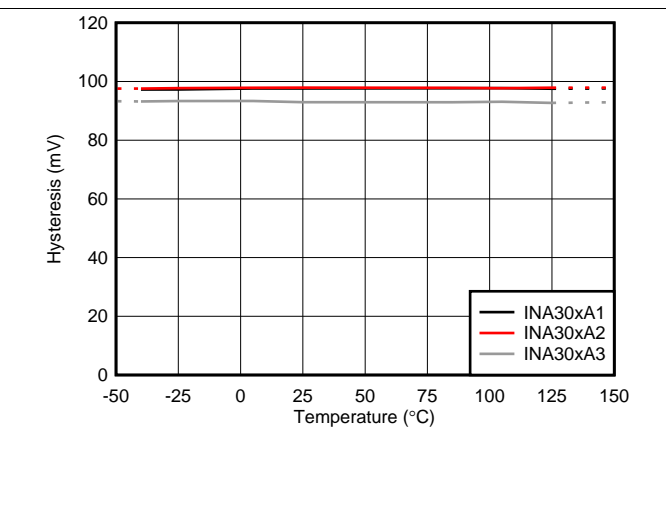
7.1 Overview

The INA30x feature a zero-drift, 36-V, common-mode, bidirectional, current-sensing amplifier, and two high-speed comparators that can detect multiple out-of-range current conditions. These specially designed, current-sensing amplifiers can be used in both low-side or high-side applications where common-mode voltages far exceed the supply voltage of the device. Currents are measured by accurately sensing voltages developed across current-sensing resistors (also known as *current-shunt resistors*). Current can be measured on input voltage rails as high as 36 V, and the device can be powered from supply voltages as low as 2.7 V.

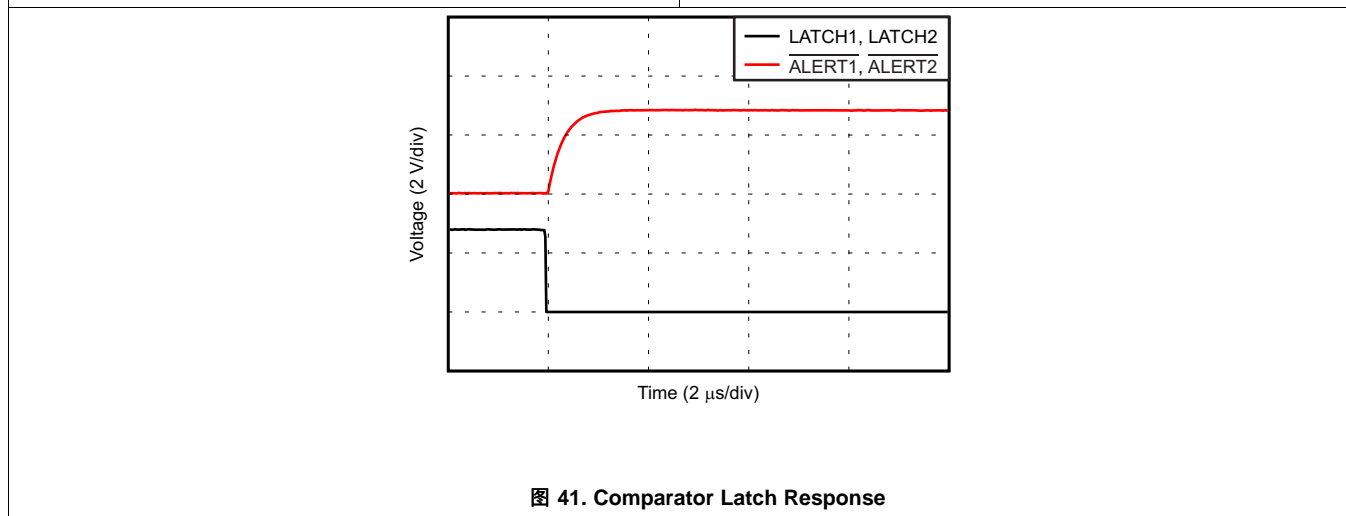
The zero-drift topology enables high-precision measurements with maximum input offset voltages as low as 30 μV (max) with a temperature contribution of only 0.25 $\mu\text{V}/^\circ\text{C}$ (max) over the full temperature range of -40°C to $+125^\circ\text{C}$. The low total offset voltage of the INA302 enables smaller current-sense resistor values to be used, improving power-efficiency without sacrificing measurement accuracy resulting from the smaller input signal.

Both devices use a single external resistor to set each out-of-range threshold. The INA302 allows for two overcurrent thresholds, and the INA303 allows for both an undercurrent and overcurrent threshold. The response time of the ALERT1 threshold is fixed and is less than 1 μs . The response time of the ALERT2 threshold can be set with an external capacitor. The combination of a precision current-sense amplifier with onboard comparators creates a highly-accurate solution that is capable of fast detection of multiple out-of-range conditions. The ability to detect when currents are out-of-range allows the system to take corrective actions to prevent potential component or system-wide damage.

7.2 Functional Block Diagram

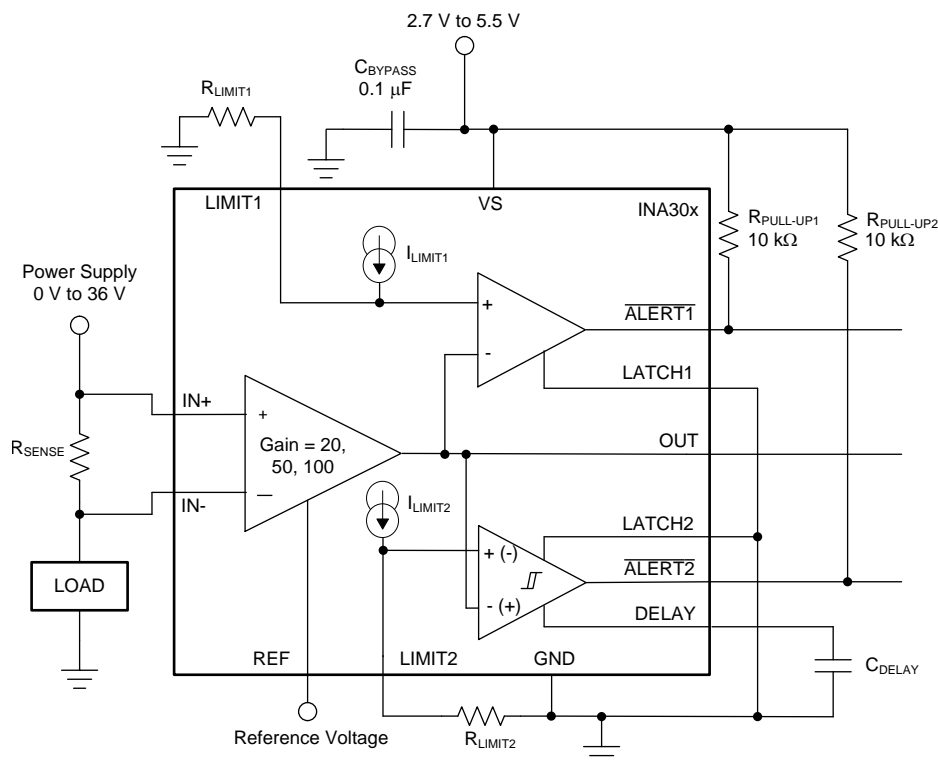

7.3 Feature Description

7.3.1 Bidirectional Current Sensing

The INA30x sense current flow through a sense resistor in both directions. The bidirectional current-sensing capability is achieved by applying a voltage at the REF pin to offset the output voltage. A positive differential voltage sensed at the inputs results in an output voltage that is greater than the applied reference voltage. Likewise, a negative differential voltage at the inputs results in output voltage that is less than the applied reference voltage. The equation for the output voltage of the current-sense amplifier is shown in [公式 1](#).

$$V_{OUT} = (I_{LOAD} \times R_{SENSE} \times GAIN) + V_{REF}$$

where

- I_{LOAD} is the load current to be monitored.
 - R_{SENSE} is the current-sense resistor.
 - GAIN is the gain option of the device selected.
 - V_{REF} is the voltage applied to the REF pin.
- (1)

7.3.2 Out-of-Range Detection

The INA303 detects when negative currents are out-of-range by setting a voltage at the LIMIT2 pin that is less than the applied reference voltage. The limit voltage is set with an external resistor or externally driven by a voltage source or digital-to-analog converter (DAC); see the [Setting Alert Thresholds](#) section for additional information. A typical application using the INA303 to detect negative overcurrent conditions is illustrated in the [Typical Application](#) section.

7.3.3 Alert Outputs

Both \overline{ALERTx} pins are active-low, open-drain outputs that pull low when the sensed current is detected to be out of range. Both open-drain \overline{ALERTx} pins require an external pullup resistor to an external supply. The external supply for the pullup voltage can exceed the supply voltage, V_S , but is restricted from operating at greater than 5.5 V. The pullup resistance is selected based on the capacitive load and required rise time; however, a 10-k Ω resistor value is typically sufficient for most applications. The response time of the $\overline{ALERT1}$ output to an out-of-range event is less than 1 μ s, and the response time of the $\overline{ALERT2}$ output is proportional to the value of the external C_{DELAY} capacitor. The equation to calculate the delay time for the $\overline{ALERT2}$ output is given in [公式 2](#):

$$t_{DELAY} = \begin{cases} 1.5 \mu\text{s} & \text{If DELAY is connected to VS with 100 k}\Omega \\ \frac{C_{DELAY} \times V_{TH}}{I_D} + 2.5 \mu\text{s} & \text{If } C_{DELAY} \geq 47 \text{ pF} \end{cases}$$

where

- C_{DELAY} is the external delay capacitor.
 - V_{TH} is the delay threshold voltage.
 - I_D is the DELAY pin current for comparator 2.
- (2)

For example, if a delay time of 10 μ s is desired, the calculated value for C_{DELAY} is 492 pF. The closest standard capacitor value to the calculated value is 500 pF. If a delay time greater than 2.5 μ s on the $\overline{ALERT2}$ output is not needed, the C_{DELAY} capacitor can be omitted. To achieve minimum delay on the $\overline{ALERT2}$ output, connect a 100-k Ω resistor from the \overline{DELAY} pin to the VS pin. Both comparators in the INA30x have hysteresis to avoid oscillations in the \overline{ALERTx} outputs. The effect hysteresis has on the comparator behavior is described in the [Hysteresis](#) section.

Feature Description (接下页)

图 42 shows the alert output response of the internal comparators for the INA302. When the output voltage of the current-sense amplifier is less than the voltage developed on either limit pin, both ALERTx outputs are in the default high state. When the current sense amplifier output is greater than the threshold voltage set by the LIMIT2 pin, the ALERT2 output pulls low after a delay time set by the external delay capacitor. The lower overcurrent threshold is commonly referred to as the *overcurrent warning threshold*. If the current continues to rise until the current-sense amplifier output voltage exceeds the threshold voltage set at the LIMIT1 pin, then the ALERT1 output becomes active and immediately pulls low. The low voltage on ALERT1 indicates that the measured signal at the amplifier input has exceeded the programmed threshold level, indicating an overcurrent condition has occurred. The upper threshold is commonly referred to as the *fault or system critical threshold*. Systems often initiate protection procedures (such as a system shutdown) when the current exceeds this threshold.



图 42. Out-of-Range Alert Responses for the INA302

Feature Description (接下页)

图 43 shows the alert output response of the internal comparators for the INA303. Both $\overline{\text{ALERT}}_x$ outputs are in the default high state when the output voltage of the current-sense amplifier is less than the voltage developed at the LIMIT1 pin and is greater than the voltage developed at the LIMIT2 pin. The $\overline{\text{ALERT}}_1$ output becomes active and pulls low when the current-sense amplifier output voltage exceeds the threshold voltage set at the LIMIT1 pin. The low voltage on $\overline{\text{ALERT}}_1$ indicates that the measured signal at the amplifier input has exceeded the programmed threshold level, indicating an overcurrent or out-of-range condition has occurred. When the current-sense amplifier output is less than the threshold voltage set by the LIMIT2 pin, the $\overline{\text{ALERT}}_2$ output pulls low after the delay time set by the external delay capacitor expires. The delay time for the $\overline{\text{ALERT}}_2$ output is proportional to the value of the external C_{DELAY} capacitor, and is calculated by 公式 2.

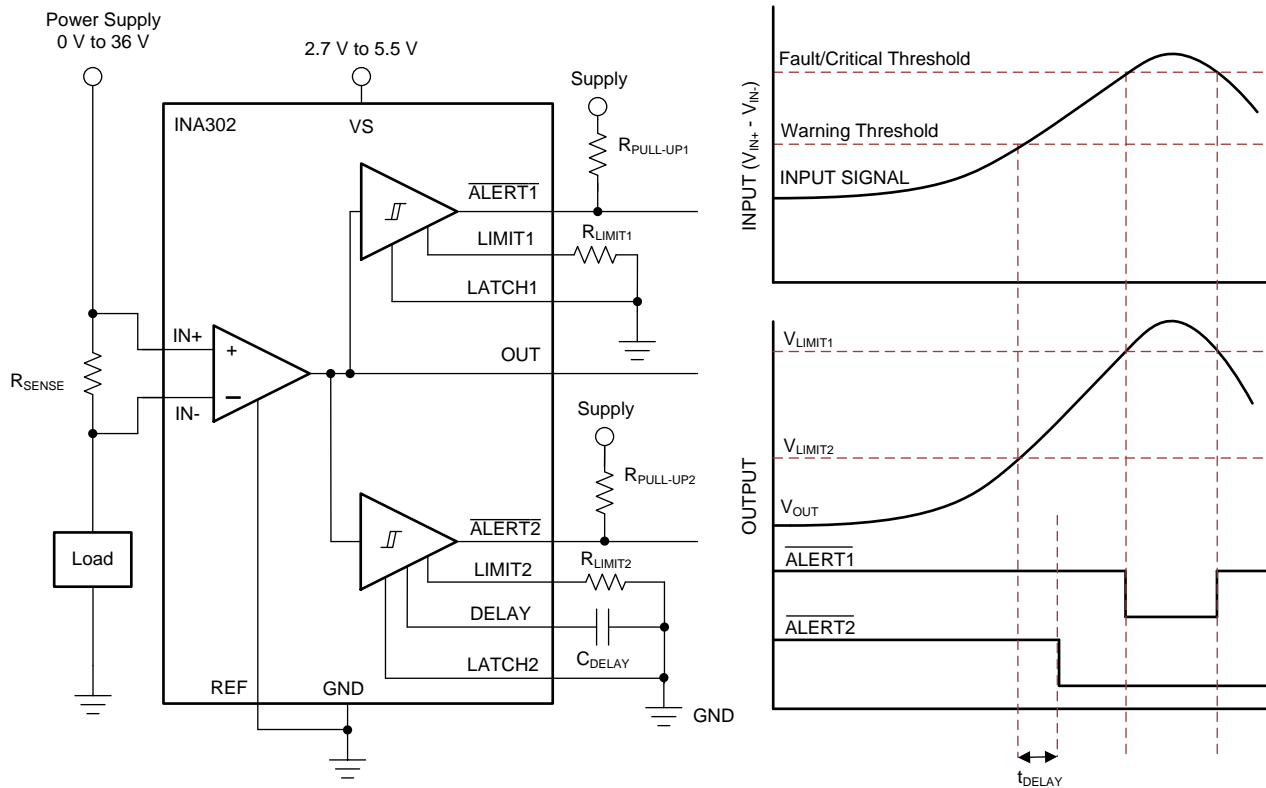

图 43. Out-of-Range Alert Responses for the INA303

Feature Description (接下页)

图 44 shows the alert output response of the INA303 when the two $\overline{\text{ALERTx}}$ pins are connected together. When configured in this manner, the INA303 can provide a single signal to indicate when the sensed current is operating either outside the normal operating bands or within a normal operational window. Both $\overline{\text{ALERT1}}$ and $\overline{\text{ALERT2}}$ outputs behave the same in regard to the alert mode. The difference with $\overline{\text{ALERT2}}$ is that the transition of the output state is delayed by the time set by the external delay capacitor. If the overcurrent or undercurrent event is not present when the delay time expires, $\overline{\text{ALERT2}}$ does not respond.

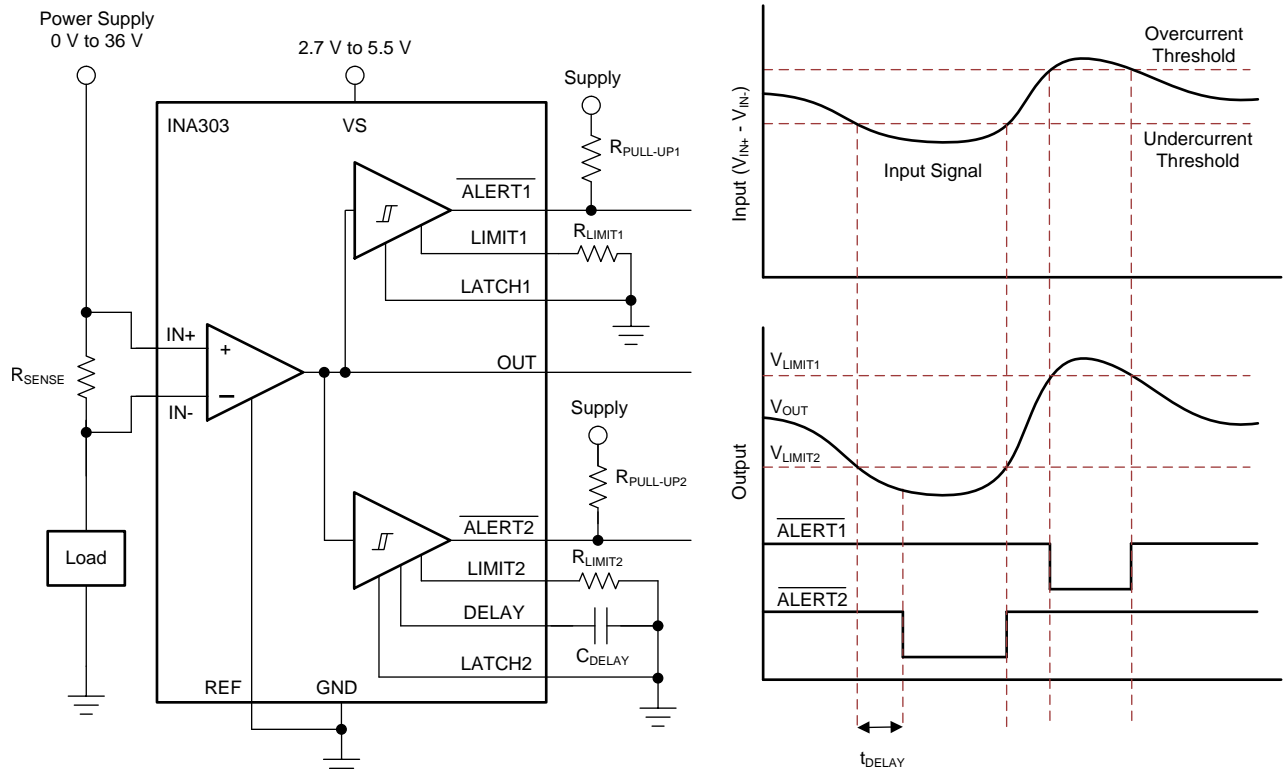

图 44. Current Window Comparator Implementation With the INA303

Feature Description (接下页)

7.3.3.1 Setting Alert Thresholds

The INA30x family of devices determines if an out-of-range event is present by comparing the amplifier output voltage to the voltage at the corresponding LIMITx pin. The threshold voltage for the LIMITx pins can be set using a single external resistor or by connecting an external voltage source to each pin. The INA302 allows setting limits for two overcurrent conditions. Generally, the lower overcurrent threshold is referred to as a *warning limit* and the higher overcurrent threshold is referred to as the *critical* or *fault limit*. The INA303 allows setting thresholds to detect both undercurrent and overcurrent limit conditions.

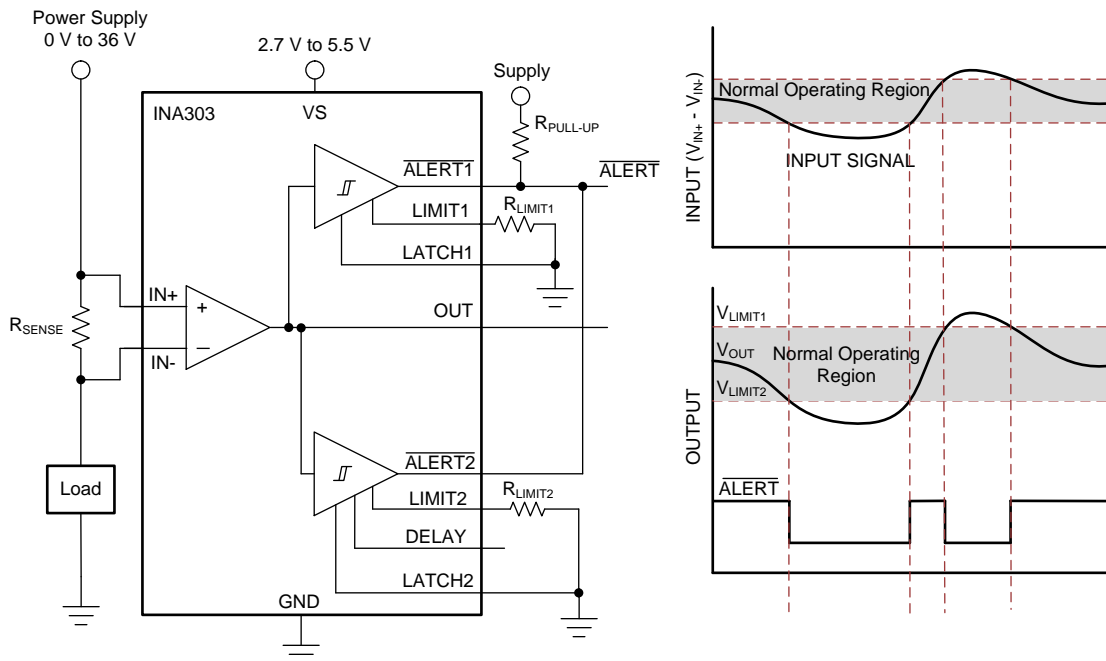
7.3.3.1.1 Resistor-Controlled Current Limit

The typical approach to set the limit threshold voltage is to connect resistors from the two LIMITx pins to ground. The voltage developed across the R_{LIMIT1} , R_{LIMIT2} resistors represents the desired fault current value at which the corresponding ALERTx pin becomes active. The values for the R_{LIMIT1} , R_{LIMIT2} resistors are calculated using [公式 3](#):

$$R_{LIMIT} = \frac{(I_{TRIP} \times R_{SENSE} \times GAIN) + V_{REF}}{I_{LIMIT}}$$

where

- I_{TRIP} is the desired out-of-range current threshold.
- R_{SENSE} is the current-sensing resistor.
- GAIN is the gain option of the device selected.
- V_{REF} is the voltage applied to the REF pin.
- I_{LIMIT} is the limit threshold output current for the selected comparator, typically 80 μ A. (3)

注

When solving for the value of R_{LIMIT} , the voltage at the corresponding LIMITx pin as determined by the product of R_{LIMIT} and I_{LIMIT} must not exceed the compliance voltage of $V_S - 0.6$ V.

7.3.3.1.1.1 Resistor-Controlled Current Limit: Example

For example, if the current level indicating an out-of-range condition (I_{TRIP}) is 20 A and the current-sense resistor value (R_{SENSE}) is 10 m Ω , then the input threshold signal is 200 mV. The INA302A1 has a gain of 20, so the resulting output voltage at the 20-A input condition is 4 V at the output of the current-sense amplifier when the REF pin is grounded. The value for R_{LIMIT} is selected to allow the device to detect this 20-A threshold, indicating that an overcurrent event has occurred. When the INA302 detects this out-of-range condition, the ALERTx pin asserts and pulls low. For this example, the value of R_{LIMIT} to detect a 4-V level is calculated to be 50 k Ω .

Feature Description (接下页)

7.3.3.1.2 Voltage-Source-Controlled Current Limit

The second method for setting the out-of-range threshold is to directly drive the LIMITx pins with a programmable DAC or other external voltage source. The benefit of this method is the ability to adjust the current-limit threshold to account for different threshold voltages used for different system operating conditions. For example, this method can be used in a system with one current-limit threshold level that must be monitored during a power-up sequence, but different threshold levels must be monitored during other system operating modes.

The voltage applied at the LIMITx pins sets the threshold voltage for out-of-range detection. The value of the voltage for a given desired current trip point is calculated using 公式 4:

$$V_{SOURCE} = (I_{TRIP} \times R_{SENSE} \times GAIN) + V_{REF}$$

where

- I_{TRIP} is the desired out-of-range current threshold.
- R_{SENSE} is the current-sensing resistor.
- $GAIN$ is the gain option of the device selected.
- V_{REF} is the voltage applied to the REF pin.

(4)

注

The maximum voltage that can be applied to the LIMIT2 pin is $V_S - 0.6\text{ V}$ and the maximum voltage that can be applied to the LIMIT1 pin must not exceed V_S .

7.3.3.2 Hysteresis

The hysteresis included in the comparators of the INA30x reduces the possibility of oscillations in the alert outputs when the measured signal level is near the overlimit threshold level. For overrange events, the corresponding ALERTx pin is asserted when the output voltage (V_{OUT}) exceeds the threshold set at either LIMITx pin. The output voltage must drop to less than the LIMITx pin threshold voltage by the hysteresis value in order for the ALERTx pin to deassert and return to the nominal high state. Likewise for underrange events, the corresponding ALERTx pin is also pulled low when the output voltage drops to less than the threshold set by either LIMITx pin. The ALERTx pin is released when the output voltage of the current-sense amplifier rises to greater than the set threshold plus hysteresis. Hysteresis functionality for both overrange and underrange events is shown in 图 45 and 图 46 for the INA302 and INA303, respectively.

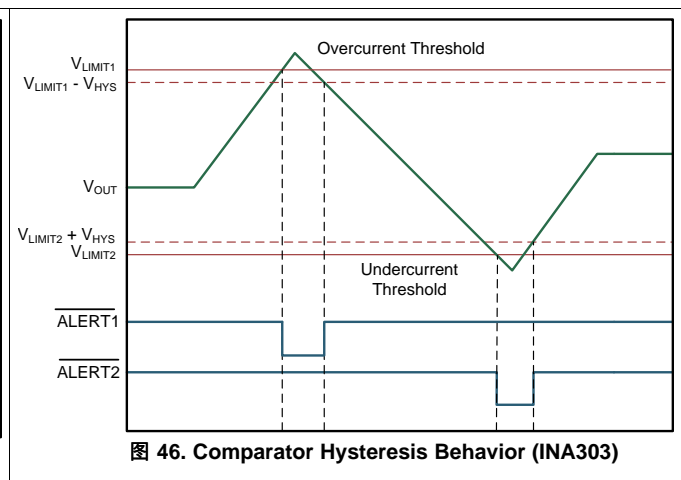
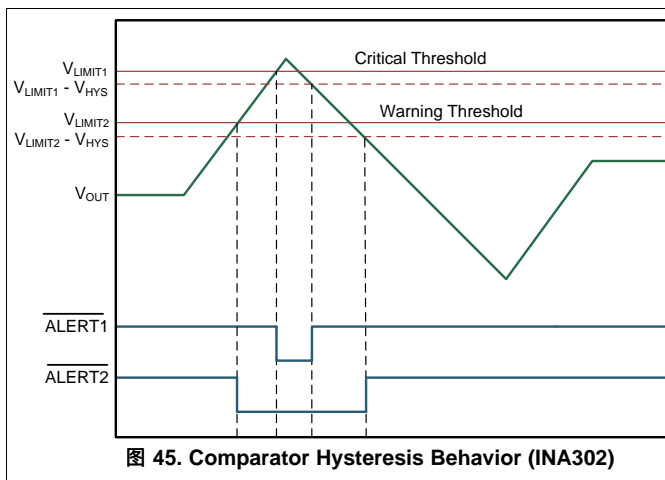

7.4 Device Functional Modes

7.4.1 Alert Operating Modes

Each comparator has two output operating modes: transparent and latched. These modes determine how the $\overline{\text{ALERTx}}$ pins respond when an out-of-range condition is removed. The device is placed into either transparent or latched state based on the voltage applied to the corresponding LATCHx pin, as shown in [表 1](#).

表 1. Output Mode Settings

OUTPUT MODE	LATCHx PINS SETTINGS
$\overline{\text{ALERTx}}$ transparent mode	LATCHx = low
$\overline{\text{ALERTx}}$ latch mode	LATCHx = high

7.4.1.1 Transparent Output Mode

The comparators are set to transparent output mode when the corresponding LATCHx pin is pulled low. When set to transparent mode, the output of the comparators changes and follows the input signal with respect to the programmed alert threshold. For example, when the amplifier output violates the set limit value, the $\overline{\text{ALERTx}}$ output pin is pulled low. As soon as the differential input signal drops to less than the alert threshold, the output returns to the default high output state. A common implementation using the device in transparent mode is to connect the $\overline{\text{ALERTx}}$ pins to a hardware interrupt input on a microcontroller. The $\overline{\text{ALERTx}}$ pin is pulled low as soon as an out-of-range condition is detected, thus notifying the microcontroller. The microcontroller immediately reacts to the alert and takes action to address the overcurrent condition. In transparent output mode, there is no need to latch the state of the alert output because the microcontroller responds as soon as the out-of-range condition occurs.

7.4.1.2 Latch Output Mode

The comparators are set to latch output mode when the corresponding LATCHx pin is pulled high. Some applications do not continuously monitor the state of the $\overline{\text{ALERTx}}$ pins as described in the [Transparent Output Mode](#) section. For example, if the device is set to transparent output mode in an application that only polls the state of the $\overline{\text{ALERTx}}$ pins periodically, then the transition of the $\overline{\text{ALERTx}}$ pins can be missed when the out-of-range condition is not present during one of these periodic polling events. Latch output mode allows the output of the comparators to latch the output of the range condition so that the transition of the $\overline{\text{ALERTx}}$ pins is not missed when the status of the comparator $\overline{\text{ALERTx}}$ pins is polled.

The difference between latch mode and transparent mode is how the alert output responds when an overcurrent condition is removed. In transparent mode (LATCH1, LATCH2 = low), when the differential input signal drops to within normal operating range, the $\overline{\text{ALERTx}}$ pin returns to the default high setting to indicate that the overcurrent event has ended.

In latch mode (LATCHx = high), when an out-of-range condition is detected and the corresponding $\overline{\text{ALERTx}}$ pin is pulled low; the $\overline{\text{ALERTx}}$ pin does not return to the default high state when the out-of-range condition is removed. In order to clear the alert, the corresponding LATCHx pin must be pulled low for at least 100 ns. Pulling the LATCHx pins low allows the corresponding $\overline{\text{ALERTx}}$ pin to return to the default high level, provided the out-of-range condition is no longer present. If the out-of-range condition is still present when the LATCHx pins are pulled low, then the corresponding $\overline{\text{ALERTx}}$ pin remains low. The $\overline{\text{ALERTx}}$ pins can be cleared (reset to high) by toggling the corresponding LATCHx pin when the alert condition is detected by the system controller.

The latch and transparent modes are illustrated in 图 47. As illustrated in this figure, at time t_1 , the current-sense amplifier exceeds the limit threshold. During this time the LATCH1 pin is toggled with no affect to the ALERT1 output. The state of the LATCH1 pin only matters when the output of the current-sense amplifier returns to the normal operating region, as shown at t_2 . At this time the LATCH1 pin is high and the overcurrent condition is latched on the ALERT1 output. As shown in the time interval between t_2 and t_3 , the latch condition is cleared when the LATCHx pin is pulled low. At time t_4 , the LATCH1 pin is already pulled low when the amplifier output drops below the limit threshold for the second time. The device is set to transparent mode at this point and the ALERT1 pin is pulled back high as soon as the output of the current-sense amplifier drops below the alert threshold.



图 47. Transparent versus Latch Mode

8 Application and Implementation

注

Information in the following applications sections is not part of the TI component specification, and TI does not warrant its accuracy or completeness. TI's customers are responsible for determining suitability of components for their purposes. Customers should validate and test their design implementation to confirm system functionality.

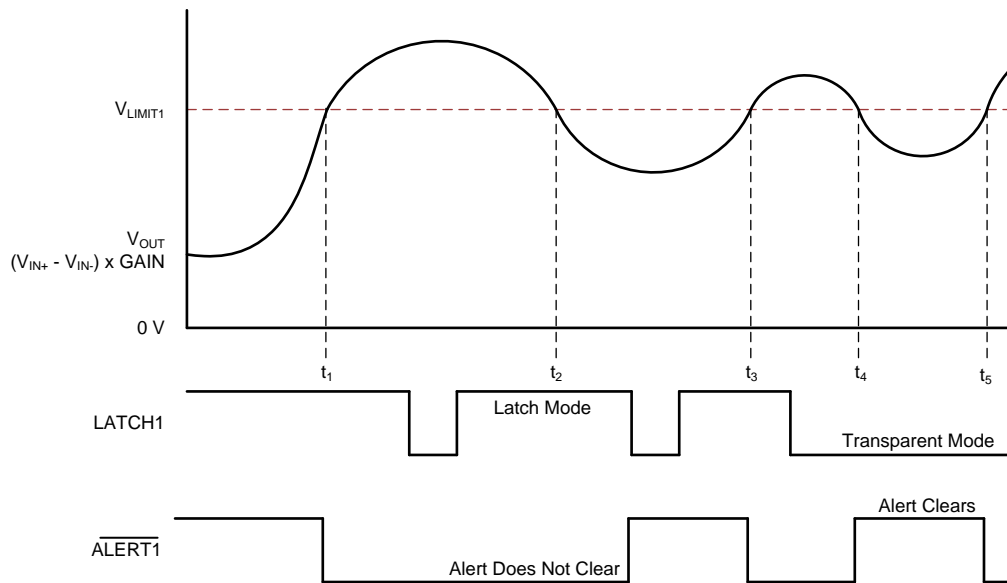
8.1 Application Information

8.1.1 Selecting a Current-Sensing Resistor (R_{SENSE})

Selecting the value of this current-sensing resistor is based primarily on two factors: the required accuracy of the current measurement and the allowable power dissipation across the current-sensing resistor. Larger voltages developed across this resistor allow for more accurate measurements to be made. Amplifiers have fixed internal errors that are largely dominated by the inherent input offset voltage. When the input signal decreases, these fixed internal amplifier errors become a larger portion of the measurement and increase the uncertainty in the measurement accuracy. When the input signal increases, the measurement uncertainty is reduced because the fixed errors are a smaller percentage of the signal being measured. Therefore, the use of larger-value, current-sensing resistors inherently improves measurement accuracy.

However, a system design trade-off must be evaluated through the use of larger input signals for improving measurement accuracy. Increasing the current-sense resistor value results in an increase in power dissipation across the current-sensing resistor. Increasing the value of the current-shunt resistor increases the differential voltage developed across the resistor when current passes through the component. This increase in voltage across the resistor increases the power that the resistor must be able to dissipate. Decreasing the value of the current-shunt resistor value reduces the power dissipation requirements of the resistor, but increases the measurement errors resulting from the decreased input signal. Selecting the optimal value for the shunt resistor requires factoring both the accuracy requirement for the specific application and the allowable power dissipation of this component.

An increasing number of very low ohmic-value resistors are becoming more widely available with values reaching down to 200 $\mu\Omega$ or lower, with power dissipations of up to 5 W that enable large currents to be accurately monitored with sensing resistors.

8.1.1.1 Selecting a Current-Sensing Resistor: Example

In this example, the trade-offs involved in selecting a current-sensing resistor are discussed. This example requires 2.5% accuracy for detecting a 10-A overcurrent event where only 250 mW is allowed for the dissipation across the current-sensing resistor at the full-scale current level. Although the maximum power dissipation is defined as 250 mW, a lower dissipation is preferred to improve system efficiency. Some initial assumptions are made that are used in this example: the limit-setting resistor (R_{LIMIT}) is a 1% component, and the maximum tolerance specification for the internal threshold setting current source (1%) is used. Given the total error budget of 2.5%, up to 0.5% of error can be attributed to the measurement error of the device under these conditions.

Application Information (接下页)

As shown in 表 2, the maximum value calculated for the current-sensing resistor with these requirements is 2.5 mΩ. Although this value satisfies the maximum power dissipation requirement of 250 mW, headroom is available from the 2.5% maximum total overcurrent detection error to reduce the value of the current-sensing resistor and to further reduce power dissipation. Selecting a 1.5-mΩ, current-sensing resistor value offers a good tradeoff for reducing the power dissipation in this scenario by approximately 40% and stays within the accuracy region.

表 2. Calculating the Current-Sensing Resistor, R_{SENSE}

PARAMETER		EQUATION	VALUE	UNIT
DESIGN TARGETS				
I _{MAX}	Maximum current		10	A
P _{D_MAX}	Maximum allowable power dissipation		250	mW
	Allowable current threshold accuracy		2.5%	
DEVICE PARAMETERS				
V _{OS}	Offset voltage		30	μV
E _G	Gain error		0.15%	
CALCULATIONS				
R _{SENSE_MAX}	Maximum allowable R _{SENSE}	P_{D_MAX} / I_{MAX}^2	2.5	mΩ
V _{OS_ERROR}	Initial offset voltage error	$(V_{OS} / (R_{SENSE_MAX} \times I_{MAX})) \times 100$	0.12%	
ERROR _{TOTAL}	Total measurement error	$\sqrt{(V_{OS_ERROR}^2 + E_G^2)}$	0.19%	
ERROR _{INITIAL}	Initial threshold error	I _{LIMIT} tolerance + R _{LIMIT} tolerance	2%	
ERROR _{AVAILABLE}	Maximum allowable measurement error	Maximum error – ERROR _{INITIAL}	1%	
V _{OS_ERROR_MAX}	Maximum allowable offset error	$\sqrt{(ERROR_{AVAILABLE}^2 - E_G^2)}$	0.48%	
V _{DIFF_MIN}	Minimum differential voltage	V _{OS} / V _{OS_ERROR_MAX} (1%)	6.3	mV
R _{SENSE_MIN}	Minimum sense resistor value	V _{DIFF_MIN} / I _{MAX}	0.63	mΩ
P _{D_MIN}	Lowest-possible power dissipation	R _{SENSE_MIN} × I _{MAX} ²	63	mW

8.1.2 Input Filtering

The integrated comparators in the INA30x are very accurate at detecting out-of-range events because of the low offset voltage; however, noise present at the input of the current-sense amplifier and noise internal to the device can make the offset appear larger than specified. The most obvious effect that external noise can have on the operation of a comparator is to cause a false alert condition. If a comparator detects a large noise transient coupled into the signal, the device can easily falsely interpret this transient as an overrange condition.

External filtering helps reduce the amount of noise that reaches the comparator and reduce the likelihood of a false alert from occurring because of external noise. The trade-off to adding this noise filter is that the alert response time is increased because the input signal and the noise are filtered. 图 48 shows the implementation of an input filter for the device.



图 48. Input Filter Implementation

Limiting the amount of input resistance used in this filter is important because this resistance can have a significant effect on the input signal that reaches the device input pins by adversely affecting the gain error of the device. A typical system implementation involves placing the current-sensing resistor very near the device so the traces are very short and the trace impedance is very small. This layout helps reduce coupling of additional noise into the measurement. Under these conditions, the characteristics of the input bias currents have minimal effect on device performance.

As shown in 图 49, the input bias currents increase in opposite directions when the differential input voltage increases. This increase results from the design of the device that allows common-mode input voltages to far exceed the device supply voltage range. When input filter resistors are placed in series with the unequal input bias currents, unequal voltage drops are developed across the input resistors. The difference between these two drops appears as an added signal that (in this case) subtracts from the voltage developed across the current-sensing resistor, thus reducing the signal that reaches the device input pins. Smaller-value input resistors reduce this effect of signal attenuation to allow for a more accurate measurement.

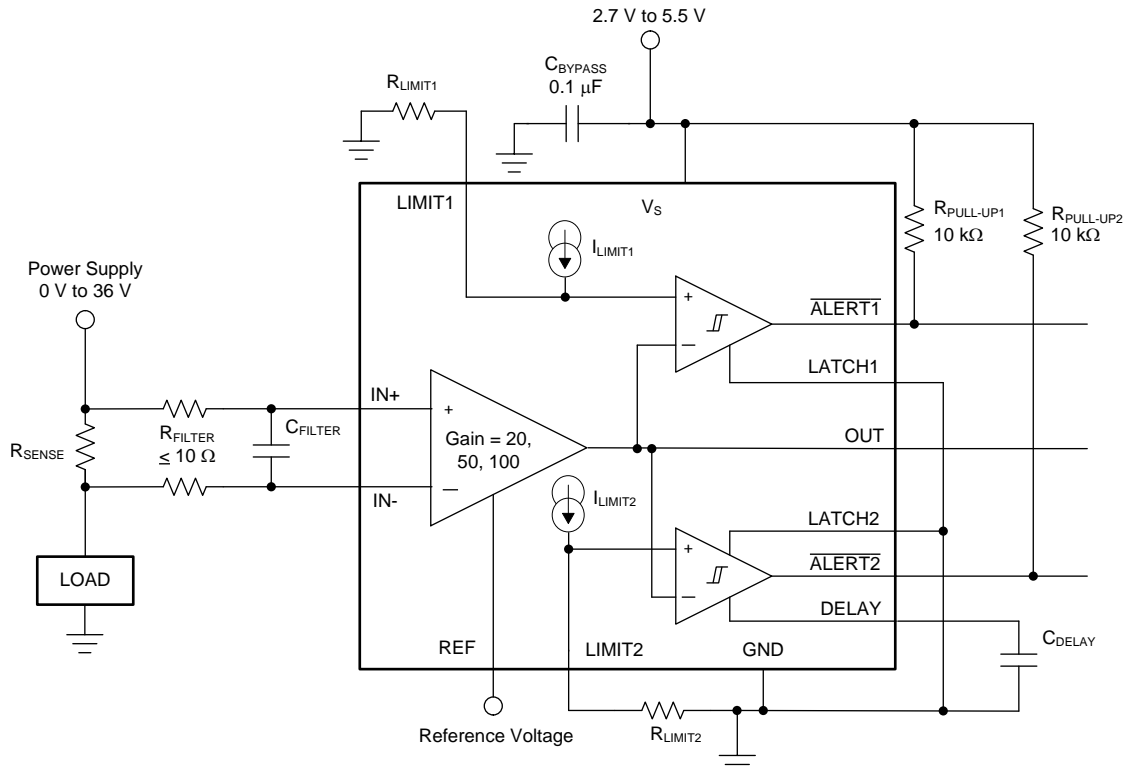

图 49. Input Bias Current vs Differential Input Voltage

The internal bias network present at the input pins shown in 图 50 is responsible for the mismatch in input bias currents that is shown in 图 49. If additional external series filter resistors are added to the circuit, the mismatch in bias currents results in a mismatch of voltage drops across the filter resistors. This mismatch creates a differential error voltage that subtracts from the voltage developed at the shunt resistor. This error results in a voltage at the device input pins that is different than the voltage developed across the shunt resistor. Without the additional series resistance, the mismatch in input bias currents has little effect on device operation. The amount of error these external filter resistors add to the measurement is calculated using 公式 6, where the gain error factor is calculated using 公式 5.

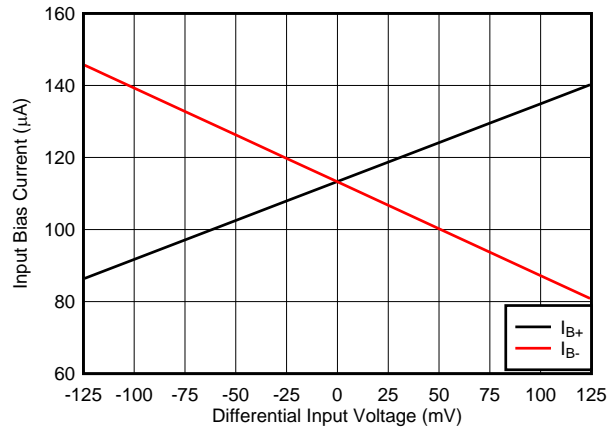
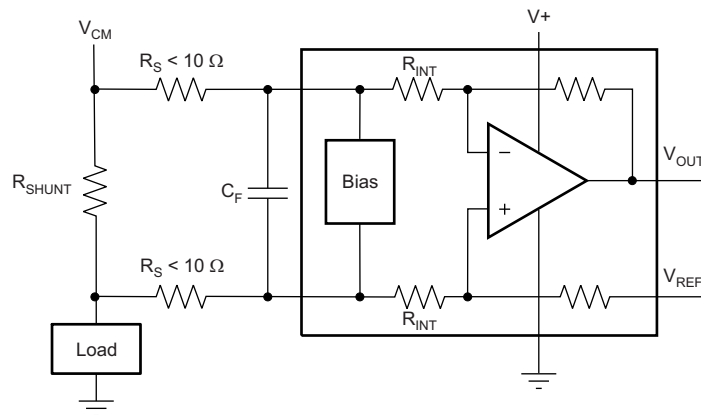

NOTE: Comparators omitted for simplicity.

图 50. Filter at Input Pins

The amount of variance in the differential voltage present at the device input relative to the voltage developed at the shunt resistor is based both on the external series resistance value as well as the internal input resistors, R3 and R4 (or R_{INT} as illustrated in [图 50](#)). The reduction of the shunt voltage reaching the device input pins appears as a gain error when comparing the output voltage relative to the voltage across the shunt resistor. A factor can be calculated to determine the amount of gain error that is introduced by the addition of external series resistance. The equation used to calculate the expected deviation from the shunt voltage to what is measured at the device input pins is given in [公式 5](#):

$$\text{Gain Error Factor} = \frac{(1250 \times R_{INT})}{(1250 \times R_S) + (1250 \times R_{INT}) + (R_S \times R_{INT})}$$

where

- R_{INT} is the internal input resistor (R3 and R4).
 - R_S is the external series resistance.
- (5)

With the adjustment factor from [公式 5](#), including the device internal input resistance, this factor varies with each gain version, as shown in [表 3](#). Each individual device gain error factor is shown in [表 4](#).

表 3. Input Resistance

PRODUCT	GAIN	R_{INT} (k Ω)
INA30xA1	20	12.5
INA30xA2	50	5
INA30xA3	100	2.5

表 4. Device Gain Error Factor

PRODUCT	SIMPLIFIED GAIN ERROR FACTOR
INA30xA1	$\frac{12,500}{(11 \times R_S) + 12,500}$
INA30xA2	$\frac{1000}{R_S + 1000}$
INA30xA3	$\frac{2500}{(3 \times R_S) + 2500}$

The gain error that is expected from the addition of the external series resistors is then calculated based on [公式 6](#):

$$\text{Gain Error (\%)} = 100 - (100 \times \text{Gain Error Factor})$$
(6)

For example, using an INA302A2 and the corresponding gain error equation from [表 4](#), a series resistance of 10 Ω results in a gain error factor of 0.99. The corresponding gain error is then calculated using [公式 6](#), resulting in a gain error of approximately 1% solely because of the external 10- Ω series resistors.

8.1.3 Using the INA30x With Common-Mode Transients Greater Than 36 V

With a small amount of additional circuitry, these devices can be used in circuits subject to transients higher than 36 V. Use only zener diodes or zener-type transient absorbers (sometimes referred to as *transzorb*s). Any other type of transient absorber has an unacceptable time delay. Start by adding a pair of resistors as a working impedance for the zener diode, as shown in [Figure 51](#). Keep these resistors as small as possible, preferably 10 Ω or less. Larger values can be used with an additional induced error resulting from a reduced signal that actually reaches the device input pins. Many applications are satisfied with a 10- Ω resistor along with conventional zener diodes of the lowest power rating available because this circuit limits only short-term transients. This combination uses the least amount of board space. These diodes can be found in packages as small as SOT-523 or SOD-523.



图 51. Transient Protection

8.2 Typical Application

The INA30x are designed to be easily configured for detecting multiple out-of-range current conditions in an application. These devices are capable of monitoring and providing overcurrent detection of bidirectional currents. By using the REF pin of the INA303, both positive and negative overcurrent events can be detected.

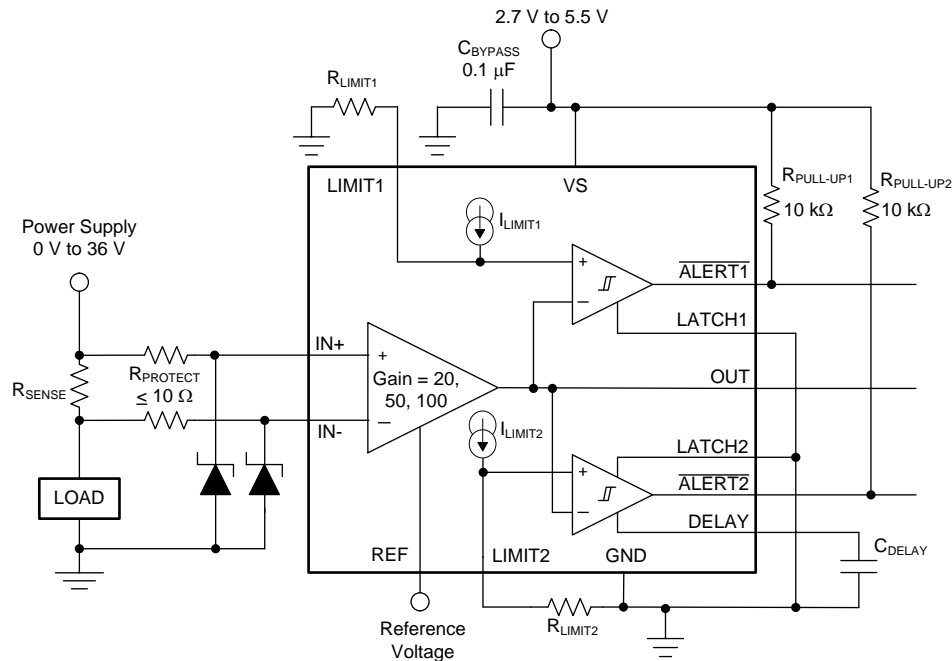

图 52. Bidirectional Application

Typical Application (接下页)

8.2.1 Design Requirements

To allow for bidirectional monitoring, the INA303 requires a voltage applied to the REF pin. A voltage that is half of the supply voltage is usually preferred to allow for maximum output swing in both the positive and negative current direction. To reduce the errors in the reference voltage, drive the REF pin with a low-impedance source (such as an op amp or external reference). A low-value resistor divider can be used at the expense of quiescent current and accuracy. For this design, a single alert output is preferred, so both ALERT1 and ALERT2 are connected together and use a single pullup resistor.

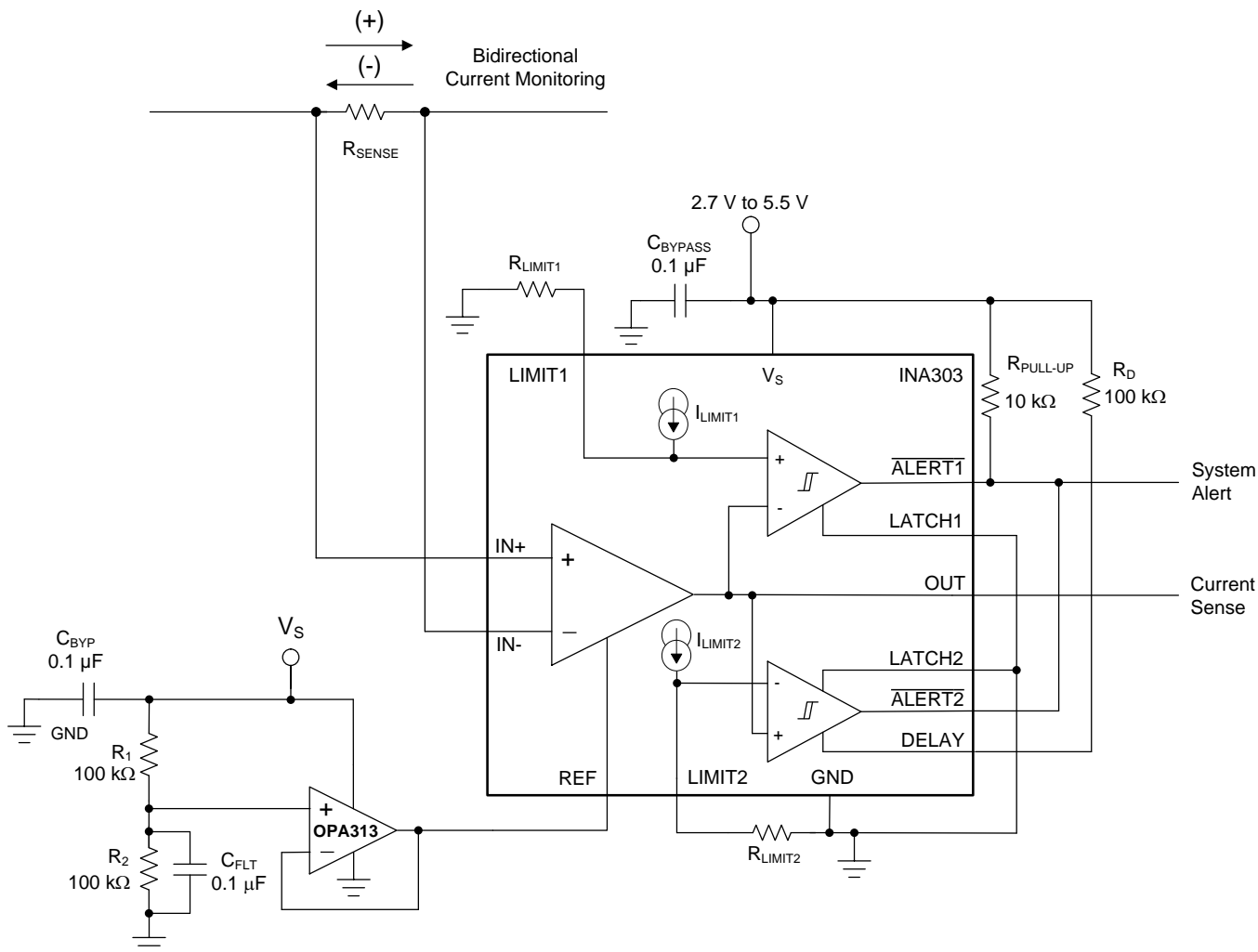
8.2.2 Detailed Design Procedure

To achieve bidirectional monitoring, drive the reference pin halfway between the supply with a resistor divider buffered by an op amp, as shown in 表 5. To reduce the current draw from the supply, use 100-k Ω resistors to create the divide-by-two voltage divider. The TLV313-Q1 is selected to buffer the voltage divider because this device can operate from a single-supply rail with low I_Q and offset voltage. To minimize the response time of the ALERT2 output, a 100-k Ω pullup resistor was added from the DELAY pin to the VS pin. Select values for R_{SENSE} , R_{LIMIT2} , and R_{LIMIT1} based on the desired current-sense levels and trip thresholds using the information in the [Resistor-Controlled Current Limit](#) and [Selecting a Current-Sensing Resistor \(\$R_{SENSE}\$ \)](#) sections. For this example, the values of R_{LIMIT1} and R_{LIMIT2} were selected so that the positive and negative overcurrent thresholds are the same. 表 5 shows the alert output of the INA303 application circuit with the capability to detect both positive and negative overcurrent conditions.

表 5. Bidirectional Overcurrent Output Status

OVERCURRENT PROTECTION (OCP) STATUS	OUTPUT
Positive overcurrent detection (OCP+)	0
Negative overcurrent detection (OCP-)	0
Normal operation (no OCP)	1

8.2.3 Application Curve

图 53 shows the INA303 device being used in a bidirectional configuration to detect both negative and positive overcurrent events.



图 53. Bidirectional Application Curve

9 Power Supply Recommendations

The device input circuitry accurately measures signals on common-mode voltages beyond the power-supply voltage, V_S . For example, the voltage applied to the V_S power-supply pin can be 5 V, whereas the load power-supply voltage being monitored (V_{CM}) can be as high as 36 V. At power-up, for applications where the common-mode voltage (V_{CM}) slew rate is greater than 6 V/ μ s with a final common-mode voltage greater than 20 V, the V_S supply is recommended to be present before V_{CM} . If the use case requires V_{CM} to be present before V_S with V_{CM} under these same slewing conditions, then a 331- Ω resistor must be added between the V_S supply and the V_S pin bypass capacitor.

Power-supply bypass capacitors are required for stability, and must be placed as close as possible to the supply and ground pins of the device. A typical value for this supply bypass capacitor is 0.1 μ F. Applications with noisy or high-impedance power supplies may require additional decoupling capacitors to reject power-supply noise.

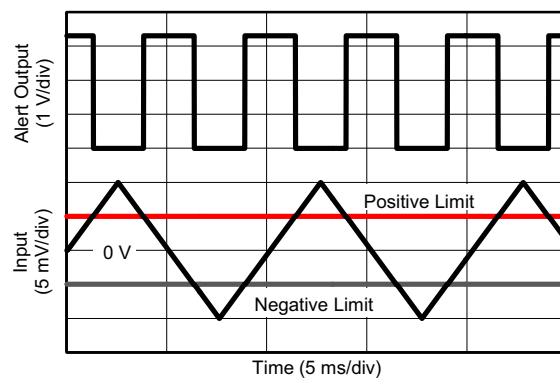
During slow power-up events, current flow through the sense resistor or voltage applied to the REF pin can result in the output voltage momentarily exceeding the voltage at the LIMITx pins, resulting in an erroneous indication of an out-of-range event on the ALERTx output. When powering the device with a slow ramping power rail where an input signal is already present, all alert indications should be disregarded until the supply voltage has reached the final value.

10 Layout

10.1 Layout Guidelines

- Apply connections to the current-sense resistor, R_{SENSE} , on the inside of the resistor pads to avoid additional voltage losses incurred by the high current traces to the resistor. Route the traces from the current-sense resistor symmetrically and side-by-side back to the input of the INA to minimize common-mode errors and noise pickup.
- Place the power-supply bypass capacitor as closely as possible to the supply and ground pins. The recommended value of this bypass capacitor is 0.1 μ F. Additional decoupling capacitance can be added to compensate for noisy or high-impedance power supplies.
- Make the connection of R_{LIMIT} to the ground pin as direct as possible to limit additional capacitance on this node. Routing this connection must be limited to the same plane if possible to avoid vias to internal planes. If the routing can not be made on the same plane and must pass through vias, make sure that a path is routed from R_{LIMIT} back to the ground pin, and that R_{LIMIT} is not simply connected directly to a ground plane.
- Routing to the delay capacitor must be short and direct. Keep the routing trace from the DELAY pin to the delay capacitor away from the $\overline{ALERT2}$ trace (or any other noisy signals) to minimize any coupling effects. If no delay capacitor is used do not have any connection to the DELAY pin. Long trace lengths on the DELAY pin can cause noise to couple to the device, resulting in false trips.
- Pull up the open-drain output pins to the supply voltage rail; a 10-k Ω pullup resistor is recommended.

10.2 Layout Example

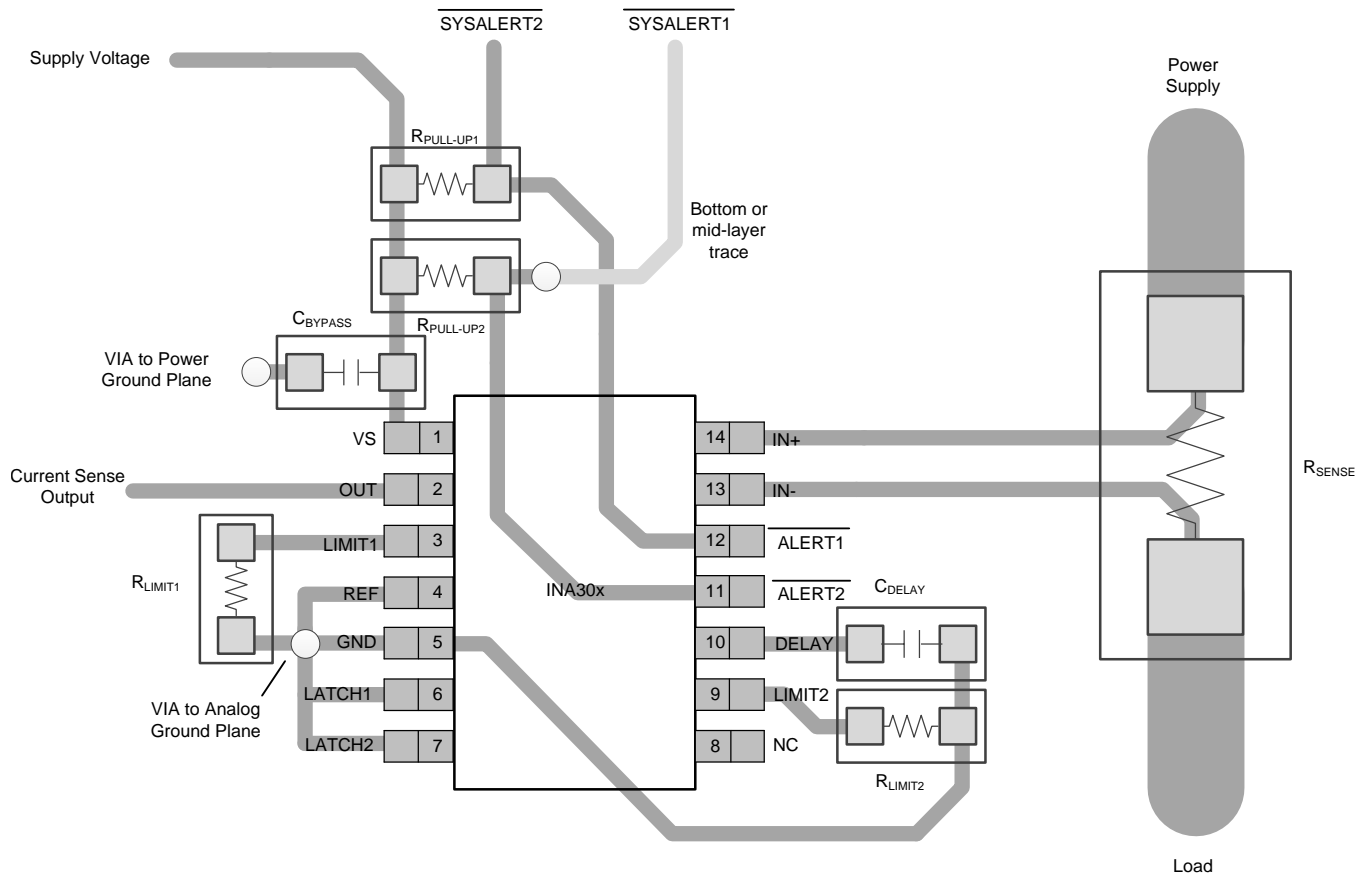

NOTE: Connect the limit resistors and delay capacitors directly to the GND pin; leave the DELAY pin unconnected or connected to VS through a pullup resistor if no delay is needed.

图 54. Recommended Layout

11 器件和文档支持

11.1 文档支持

11.1.1 相关文档

请参阅如下相关文档:

- 德州仪器 (TI), 《[TLVx313-Q1 低功耗轨至轨输入/输出 750 \$\mu\$ V 典型失调电压运算放大器](#)》数据表
- 德州仪器 (TI), 《[监测电流以识别多种超出范围的情况](#)》应用报告

11.2 相关链接

表 6 列出了快速访问链接。类别包括技术文档、支持和社区资源、工具与软件，以及立即订购快速访问。

表 6. 相关链接

器件	产品文件夹	立即订购	技术文档	工具与软件	支持和社区
INA302	请单击此处	请单击此处	请单击此处	请单击此处	请单击此处
INA303	请单击此处	请单击此处	请单击此处	请单击此处	请单击此处

11.3 接收文档更新通知

要接收文档更新通知，请导航至 TI.com.cn 上的器件产品文件夹。单击右上角的 [通知我](#) 进行注册，即可每周接收产品信息更改摘要。有关更改的详细信息，请查看任何已修订文档中包含的修订历史记录。

11.4 社区资源

下列链接提供到 TI 社区资源的连接。链接的内容由各个分销商“按照原样”提供。这些内容并不构成 TI 技术规范，并且不一定反映 TI 的观点；请参阅 TI 的 [《使用条款》](#)。

TI E2E™ Online Community *TI's Engineer-to-Engineer (E2E) Community*. Created to foster collaboration among engineers. At e2e.ti.com, you can ask questions, share knowledge, explore ideas and help solve problems with fellow engineers.

Design Support *TI's Design Support* Quickly find helpful E2E forums along with design support tools and contact information for technical support.

11.5 商标

E2E is a trademark of Texas Instruments.

All other trademarks are the property of their respective owners.

11.6 静电放电警告



ESD 可能会损坏该集成电路。德州仪器 (TI) 建议通过适当的预防措施处理所有集成电路。如果不遵守正确的处理措施和安装程序，可能会损坏集成电路。

ESD 的损坏小至导致微小的性能降级，大至整个器件故障。精密的集成电路可能更容易受到损坏，这是因为非常细微的参数更改都可能会导致器件与其发布的规格不相符。

11.7 术语表

SLYZ022 — TI 术语表。

这份术语表列出并解释术语、缩写和定义。

12 机械、封装和可订购信息

以下页面包含机械、封装和可订购信息。这些信息是指定器件的最新可用数据。数据如有变更，恕不另行通知，且不会对此文档进行修订。如需获取此数据表的浏览器版本，请查阅左侧的导航栏。

PACKAGING INFORMATION

Orderable Device	Status (1)	Package Type	Package Drawing	Pins	Package Qty	Eco Plan (2)	Lead finish/ Ball material (6)	MSL Peak Temp (3)	Op Temp (°C)	Device Marking (4/5)	Samples
INA302A1IPW	ACTIVE	TSSOP	PW	14	90	RoHS & Green	NIPDAU	Level-2-260C-1 YEAR	-40 to 125	I302A1	Samples
INA302A1IPWR	ACTIVE	TSSOP	PW	14	2000	RoHS & Green	NIPDAU	Level-2-260C-1 YEAR	-40 to 125	I302A1	Samples
INA302A2IPW	ACTIVE	TSSOP	PW	14	90	RoHS & Green	NIPDAU	Level-2-260C-1 YEAR	-40 to 125	I302A2	Samples
INA302A2IPWR	ACTIVE	TSSOP	PW	14	2000	RoHS & Green	NIPDAU	Level-2-260C-1 YEAR	-40 to 125	I302A2	Samples
INA302A3IPW	ACTIVE	TSSOP	PW	14	90	RoHS & Green	NIPDAU	Level-2-260C-1 YEAR	-40 to 125	I302A3	Samples
INA302A3IPWR	ACTIVE	TSSOP	PW	14	2000	RoHS & Green	NIPDAU	Level-2-260C-1 YEAR	-40 to 125	I302A3	Samples
INA303A1IPW	ACTIVE	TSSOP	PW	14	90	RoHS & Green	NIPDAU	Level-2-260C-1 YEAR	-40 to 125	I303A1	Samples
INA303A1IPWR	ACTIVE	TSSOP	PW	14	2000	RoHS & Green	NIPDAU	Level-2-260C-1 YEAR	-40 to 125	I303A1	Samples
INA303A2IPW	ACTIVE	TSSOP	PW	14	90	RoHS & Green	NIPDAU	Level-2-260C-1 YEAR	-40 to 125	I303A2	Samples
INA303A2IPWR	ACTIVE	TSSOP	PW	14	2000	RoHS & Green	NIPDAU	Level-2-260C-1 YEAR	-40 to 125	I303A2	Samples
INA303A3IPW	ACTIVE	TSSOP	PW	14	90	RoHS & Green	NIPDAU	Level-2-260C-1 YEAR	-40 to 125	I303A3	Samples
INA303A3IPWR	ACTIVE	TSSOP	PW	14	2000	RoHS & Green	NIPDAU	Level-2-260C-1 YEAR	-40 to 125	I303A3	Samples

(1) The marketing status values are defined as follows:

ACTIVE: Product device recommended for new designs.

LIFEBUY: TI has announced that the device will be discontinued, and a lifetime-buy period is in effect.

NRND: Not recommended for new designs. Device is in production to support existing customers, but TI does not recommend using this part in a new design.

PREVIEW: Device has been announced but is not in production. Samples may or may not be available.

OBSOLETE: TI has discontinued the production of the device.

(2) **RoHS:** TI defines "RoHS" to mean semiconductor products that are compliant with the current EU RoHS requirements for all 10 RoHS substances, including the requirement that RoHS substance do not exceed 0.1% by weight in homogeneous materials. Where designed to be soldered at high temperatures, "RoHS" products are suitable for use in specified lead-free processes. TI may reference these types of products as "Pb-Free".

RoHS Exempt: TI defines "RoHS Exempt" to mean products that contain lead but are compliant with EU RoHS pursuant to a specific EU RoHS exemption.

Green: TI defines "Green" to mean the content of Chlorine (Cl) and Bromine (Br) based flame retardants meet JS709B low halogen requirements of <=1000ppm threshold. Antimony trioxide based flame retardants must also meet the <=1000ppm threshold requirement.

- (3) MSL, Peak Temp. - The Moisture Sensitivity Level rating according to the JEDEC industry standard classifications, and peak solder temperature.
- (4) There may be additional marking, which relates to the logo, the lot trace code information, or the environmental category on the device.
- (5) Multiple Device Markings will be inside parentheses. Only one Device Marking contained in parentheses and separated by a "~" will appear on a device. If a line is indented then it is a continuation of the previous line and the two combined represent the entire Device Marking for that device.
- (6) Lead finish/Ball material - Orderable Devices may have multiple material finish options. Finish options are separated by a vertical ruled line. Lead finish/Ball material values may wrap to two lines if the finish value exceeds the maximum column width.

Important Information and Disclaimer:The information provided on this page represents TI's knowledge and belief as of the date that it is provided. TI bases its knowledge and belief on information provided by third parties, and makes no representation or warranty as to the accuracy of such information. Efforts are underway to better integrate information from third parties. TI has taken and continues to take reasonable steps to provide representative and accurate information but may not have conducted destructive testing or chemical analysis on incoming materials and chemicals. TI and TI suppliers consider certain information to be proprietary, and thus CAS numbers and other limited information may not be available for release.

In no event shall TI's liability arising out of such information exceed the total purchase price of the TI part(s) at issue in this document sold by TI to Customer on an annual basis.

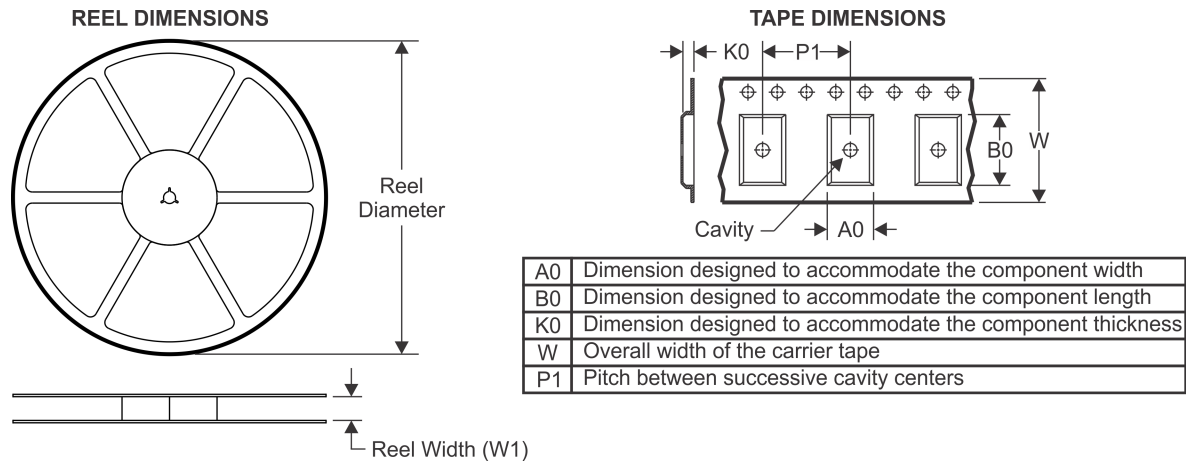
TAPE AND REEL INFORMATION

QUADRANT ASSIGNMENTS FOR PIN 1 ORIENTATION IN TAPE



*All dimensions are nominal

Device	Package Type	Package Drawing	Pins	SPQ	Reel Diameter (mm)	Reel Width W1 (mm)	A0 (mm)	B0 (mm)	K0 (mm)	P1 (mm)	W (mm)	Pin1 Quadrant
INA302A1IPWR	TSSOP	PW	14	2000	330.0	12.4	6.9	5.6	1.6	8.0	12.0	Q1
INA302A2IPWR	TSSOP	PW	14	2000	330.0	12.4	6.9	5.6	1.6	8.0	12.0	Q1
INA302A3IPWR	TSSOP	PW	14	2000	330.0	12.4	6.9	5.6	1.6	8.0	12.0	Q1
INA303A1IPWR	TSSOP	PW	14	2000	330.0	12.4	6.9	5.6	1.6	8.0	12.0	Q1
INA303A2IPWR	TSSOP	PW	14	2000	330.0	12.4	6.9	5.6	1.6	8.0	12.0	Q1
INA303A3IPWR	TSSOP	PW	14	2000	330.0	12.4	6.9	5.6	1.6	8.0	12.0	Q1

TAPE AND REEL BOX DIMENSIONS

*All dimensions are nominal

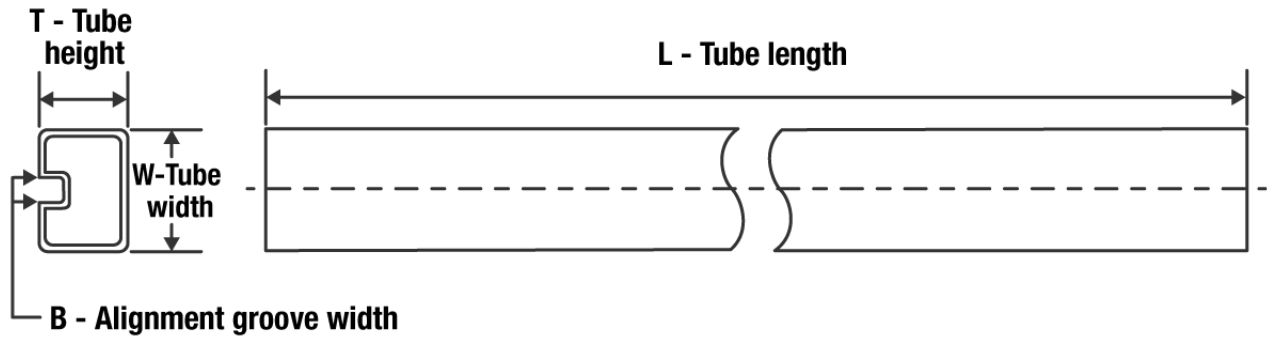
Device	Package Type	Package Drawing	Pins	SPQ	Length (mm)	Width (mm)	Height (mm)
INA302A1PWR	TSSOP	PW	14	2000	853.0	449.0	35.0
INA302A2IPWR	TSSOP	PW	14	2000	853.0	449.0	35.0
INA302A3IPWR	TSSOP	PW	14	2000	853.0	449.0	35.0
INA303A1IPWR	TSSOP	PW	14	2000	853.0	449.0	35.0
INA303A2IPWR	TSSOP	PW	14	2000	853.0	449.0	35.0
INA303A3IPWR	TSSOP	PW	14	2000	853.0	449.0	35.0

TUBE

*All dimensions are nominal

Device	Package Name	Package Type	Pins	SPQ	L (mm)	W (mm)	T (μm)	B (mm)
INA302A1IPW	PW	TSSOP	14	90	530	10.2	3600	3.5
INA302A2IPW	PW	TSSOP	14	90	530	10.2	3600	3.5
INA302A3IPW	PW	TSSOP	14	90	530	10.2	3600	3.5
INA303A1IPW	PW	TSSOP	14	90	530	10.2	3600	3.5
INA303A2IPW	PW	TSSOP	14	90	530	10.2	3600	3.5
INA303A3IPW	PW	TSSOP	14	90	530	10.2	3600	3.5

PW (R-PDSO-G14)

PLASTIC SMALL OUTLINE



4211284-2/G 08/15

- NOTES:
- All linear dimensions are in millimeters.
 - This drawing is subject to change without notice.
 - Publication IPC-7351 is recommended for alternate designs.
 - Laser cutting apertures with trapezoidal walls and also rounding corners will offer better paste release. Customers should contact their board assembly site for stencil design recommendations. Refer to IPC-7525 for other stencil recommendations.
 - Customers should contact their board fabrication site for solder mask tolerances between and around signal pads.

重要声明和免责声明

TI“按原样”提供技术和可靠性数据（包括数据表）、设计资源（包括参考设计）、应用或其他设计建议、网络工具、安全信息和其他资源，不保证没有瑕疵且不做任何明示或暗示的担保，包括但不限于对适销性、某特定用途方面的适用性或不侵犯任何第三方知识产权的暗示担保。

这些资源可供使用 TI 产品进行设计的熟练开发人员使用。您将自行承担以下全部责任：(1) 针对您的应用选择合适的 TI 产品，(2) 设计、验证并测试您的应用，(3) 确保您的应用满足相应标准以及任何其他功能安全、信息安全、监管或其他要求。

这些资源如有变更，恕不另行通知。TI 授权您仅可将这些资源用于研发本资源所述的 TI 产品的应用。严禁对这些资源进行其他复制或展示。您无权使用任何其他 TI 知识产权或任何第三方知识产权。您应全额赔偿因在这些资源的使用中对 TI 及其代表造成的任何索赔、损害、成本、损失和债务，TI 对此概不负责。

TI 提供的产品受 [TI 的销售条款](#) 或 [ti.com](#) 上其他适用条款/TI 产品随附的其他适用条款的约束。TI 提供这些资源并不会扩展或以其他方式更改 TI 针对 TI 产品发布的适用的担保或担保免责声明。

TI 反对并拒绝您可能提出的任何其他或不同的条款。

邮寄地址：Texas Instruments, Post Office Box 655303, Dallas, Texas 75265

Copyright © 2022，德州仪器 (TI) 公司