

bq25100B 250mA 单节锂离子电池充电器, 1mA 终止电流、75nA 电池泄漏电流

1 特性

- 充电中
 - 1% 充电电压准确度
 - 10% 充电电流准确度
 - 支持 充电电流 超低 (10mA 至 250mA) 的应用
 - 最低支持 1mA 充电终止电流
 - 超低电池输出泄漏电流: 75nA (最大值)
 - 可调节的终止和预充电阈值
 - 高电压化学支持: 4.30V
- 保护
 - 30V 额定输入电压; 具有 6.5V 输入过压保护
 - 输入电压动态电源管理
 - 125°C 热调节; 150°C 热关断保护
 - OUT 短路保护和 ISET 短路检测
 - 固定 10 小时安全定时器
- 系统
 - 针对电池组缺失情况的自动终止和定时器禁用模式 (TTDM)
 - 采用小型 1.60mm × 0.90mm 芯片尺寸球状引脚栅格阵列 (DSBGA) 封装

2 应用

- 健身配件
- 智能手表
- Bluetooth® 耳机
- 低功耗手持器件

3 说明

bq25100B 器件是一款面向空间受限类便携式应用的高度集成锂离子和锂聚合物线性充电器。具有输入过压保护的高输入电压范围支持低成本、未稳压的适配器。

bq25100B 具有一个可为电池充电的电源输出。如果在 10 小时的安全定时器期间内平均系统负载无法让电池充满电, 则可以使系统负载与电池并联。

电池充电经历以下三个阶段: 调节, 恒定电流和恒定电压。在所有充电阶段, 内部控制环路都会监控 IC 结温, 当其超过内部温度阈值时, 它会减少充电电流。

充电器功率级和充电电流感测功能均完全集成。该充电器具有高精度电流和电压调节环路以及充电终止功能。预充电电流和终止电流阈值可通过 bq25100B 上的一个外部电阻进行编程。快速充电电流值也可通过一个外部电阻进行编程。

本文档包含针对 bq25100B 系列中其他器件的引用。有关这些器件的更多信息, 请参见相应数据表。本文档引用了 **CHG** 引脚和 **JEITA** 温度功能。

器件信息(1)

器件型号	封装	封装尺寸 (标称值)
bq25100B	DSBGA (6)	1.60mm × 0.90mm

(1) 要了解所有可用封装, 请见数据表末尾的可订购产品附录。

典型应用图

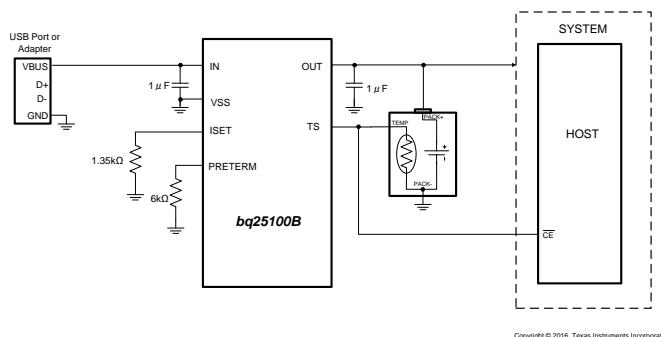

目录

1	特性	1	8.4	Device Functional Modes	18
2	应用	1	9	Application and Implementation	22
3	说明	1	9.1	Application Information	22
4	修订历史记录	2	9.2	Typical Application	22
5	Device Comparison Table	3	10	Power Supply Recommendations	24
6	Pin Configuration and Functions	3	10.1	Leakage Current Effects on Battery Capacity	24
7	Specifications	4	11	Layout	24
7.1	Absolute Maximum Ratings	4	11.1	Layout Guidelines	24
7.2	ESD Ratings	4	11.2	Layout Example	25
7.3	Recommended Operating Conditions	4	11.3	Thermal Considerations	25
7.4	Thermal Information	5	12	器件和文档支持	26
7.5	Electrical Characteristics	5	12.1	器件支持	26
7.6	Typical Characteristics	9	12.2	相关链接	26
8	Detailed Description	12	12.3	商标	26
8.1	Overview	12	12.4	静电放电警告	26
8.2	Functional Block Diagram	14	12.5	Glossary	26
8.3	Feature Description	15	13	机械、封装和可订购信息	26

4 修订历史记录

日期	修订版本	注释
2016 年 4 月	*	最初发布。

5 Device Comparison Table

PART NUMBER	$V_{O(REG)}$	V_{OVP}	PreTerm \overline{CHG}	TS
bq25100	4.20 V	6.5 V	PreTerm	TS (JEITA)
bq25101	4.20 V	6.5 V	\overline{CHG}	TS (JEITA)
bq25100A	4.30 V	6.5 V	PreTerm	TS
bq25100B ⁽¹⁾	4.284 V	6.5 V	PreTerm	TS
bq25100H	4.35 V	6.5 V	PreTerm	TS (JEITA)
bq25101H	4.35 V	6.5 V	\overline{CHG}	TS (JEITA)
bq25100L ⁽²⁾	4.06 V	6.5 V	PreTerm	TS

- (1) The bq25100B is part of the bq25100 family of devices. Please see [器件支持](#) for viewing other devices.
(2) Product preview. Contact the local TI representative for device details.

6 Pin Configuration and Functions

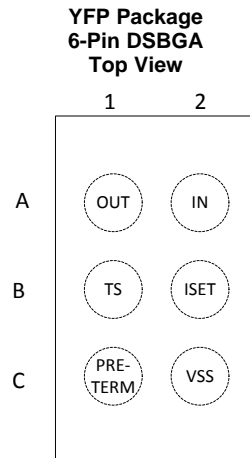

Pin Functions

PIN		I/O	DESCRIPTION
NAME	NUMBER		
IN	A2	I	Input power, connected to external DC supply (AC adapter or USB port). Expected range of bypass capacitors 1 μ F to 10 μ F, connect from IN to V_{SS} .
ISET	B2	I	Programs the fast-charge current setting. External resistor from ISET to VSS defines fast charge current value. Recommended range is 13.5 k Ω (10 mA) to 0.54 k Ω (250 mA).
OUT	A1	O	Battery Connection. System Load may be connected. Expected range of bypass capacitors 1 μ F to 10 μ F.
PRE-TERM	C1	I	Programs the current termination threshold (1% to 50% of I_{OUT} , 1 mA minimum). The pre-charge current is twice the termination current level. Expected range of programming resistor is 600 Ω to 30 k Ω (6k: $I_{CHG}/10$ for term; $I_{CHG}/5$ for precharge)
TS	B1	I	Temperature sense pin connected to 10k at 25 $^{\circ}$ C NTC thermistor, in the battery pack. Floating TS pin or pulling high puts part in TTDM <i>Charger</i> mode and disables TS monitoring, Timers and Termination. Pulling pin low disables the IC. If NTC sensing is not needed, connect this pin to VSS through an external 10-k Ω resistor. A 250-k Ω resistor from TS to ground will prevent IC entering TTDM mode when battery with thermistor is removed.
VSS	C2	–	Ground pin

7 Specifications

7.1 Absolute Maximum Ratings

 over operating free-air temperature range (unless otherwise noted)⁽¹⁾

		MIN	MAX	UNIT
Input voltage	IN (with respect to VSS)	-0.3	30	V
	OUT (with respect to VSS)	-0.3	7	V
	PRE-TERM, ISET, TS, $\overline{\text{CHG}}$ (with respect to VSS)	-0.3	7	V
Input current	IN		300	mA
Output current (continuous)	OUT		300	mA
Output sink current	$\overline{\text{CHG}}$		15	mA
T _J	Junction temperature	-40	150	°C
T _{stg}	Storage temperature	-65	150	°C

- (1) Stresses beyond those listed under absolute maximum ratings may cause permanent damage to the device. These are stress ratings only, and functional operation of the device at these or any other conditions beyond those indicated under recommended operating conditions is not implied. Exposure to absolute-maximum-rated conditions for extended periods may affect device reliability. All voltage values are with respect to the network ground terminal unless otherwise noted.

7.2 ESD Ratings

			VALUE	UNIT
V _(ESD)	Electrostatic discharge	IEC61000-4-2 contact discharge ⁽¹⁾	±8000	V
		IEC61000-4-2 air-gap discharge ⁽¹⁾	±15000	

- (1) The test was performed on IC pins that may potentially be exposed to the customer at the product level. The bq2510x IC requires a minimum of the listed capacitance, external to the IC, to pass the ESD test.
- (2) 1 μF between IN (pin A2) and GND,
 1 μF between TS (pin B1) and GND,
 2 μF between OUT (pin A1) and GND,
 x5R ceramic or equivalent

7.3 Recommended Operating Conditions

 see ⁽¹⁾

		MIN	NOM	UNIT
V _{IN}	IN voltage	3.5	28	V
	IN operating voltage, restricted by V _{DPM} and V _{OVP}	4.45	6.45	V
I _{IN}	Input current, IN pin		250	mA
I _{OUT}	Current, OUT pin		250	mA
R _{PRE-TERM}	Programs precharge and termination current thresholds	0.6	30	k Ω
R _{ISET}	Fast-charge current programming resistor	0.54	13.5	k Ω
R _{TS}	10k NTC thermistor range without entering $\overline{\text{BAT_EN}}$ or TTDM	1.66	258	k Ω
T _J	Junction temperature	-5	125	°C

- (1) Operation with V_{IN} less than 4.5V or in drop-out may result in reduced performance.

7.4 Thermal Information

THERMAL METRIC ⁽¹⁾		bq25100B	UNIT
		YFP (DSBGA)	
		6 PINS	
R _{θJA}	Junction-to-ambient thermal resistance	132.9	°C/W
R _{θJctop}	Junction-to-case (top) thermal resistance	1.3	°C/W
R _{θJB}	Junction-to-board thermal resistance	21.8	°C/W
ψ _{JT}	Junction-to-top characterization parameter	5.6	°C/W
ψ _{JB}	Junction-to-board characterization parameter	21.8	°C/W
R _{θJcbot}	Junction-to-case (bottom) thermal resistance	—	°C/W

(1) For more information about traditional and new thermal metrics, see the *Semiconductor and IC Package Thermal Metrics* application report, [SPRA953](#).

7.5 Electrical Characteristics

Over junction temperature range $-5^{\circ}\text{C} \leq T_J \leq 125^{\circ}\text{C}$ and recommended supply voltage (unless otherwise noted)

PARAMETER	TEST CONDITIONS	MIN	TYP	MAX	UNIT	
INPUT						
UVLO	Undervoltage lockout exit	V _{IN} : 0 V → 4 V	3.15	3.3	3.45	V
V _{HYS_UVLO}	Hysteresis on V _{UVLO_RISE} falling	V _{IN} : 4 V → 0 V; V _{UVLO_FALL} = V _{UVLO_RISE} - V _{HYS_UVLO}		263		mV
V _{IN-DT}	Input power good detection threshold is V _{OUT} + V _{IN-DT}	Input power good if V _{IN} > V _{OUT} + V _{IN-DT} ; V _{OUT} = 3.6 V; V _{IN} : 3.5 V → 4 V	15	60	130	mV
V _{HYS-INDT}	Hysteresis on V _{IN-DT} falling	V _{OUT} = 3.6 V; V _{IN} : 4 V → 3.5 V		31		mV
t _{DGL(PG_PWR)}	Deglintch time on exiting sleep	Time measured from V _{IN} : 0 V → 5 V 1-μs rise-time to charge enables; V _{OUT} = 3.6 V		29		ms
t _{DGL(PG_NO-PWR)}	Deglintch time on V _{HYS-INDT} power down. Same as entering sleep.	Time measured from V _{IN} : 5 V → 3.2 V 1-μs fall-time to charge disables; V _{OUT} = 3.6 V		29		ms
V _{OVP}	Input over-voltage protection threshold	V _{IN} : 5 V → 12 V	6.50	6.65	6.84	V
t _{DGL(OVP-SET)}	Input over-voltage blanking time	V _{IN} : 5 V → 12 V		113		μs
V _{HYS-OVP}	Hysteresis on OVP	V _{IN} : 11 V → 5 V		110		mV
t _{DGL(OVP-REC)}	Deglintch time exiting OVP	Time measured from V _{IN} : 12 V → 5 V 1-μs fall-time to charge enables		450		μs
V _{IN-DPM}	Low input voltage protection. Restricts I _{OUT} at V _{IN-DPM} .	Limit input source current to 50 mA; V _{OUT} = 3.5 V; R _{ISET} = 1.35 kΩ	4.25	4.31	4.37	V
ISET SHORT CIRCUIT TEST						
R _{ISET_SHORT}	Highest resistor value considered a fault (short).	R _{ISET} : 540 Ω → 250 Ω, I _{OUT} latches off; Cycle power to reset		426	470	Ω
t _{DGL_SHORT}	Deglintch time transition from ISET short to I _{OUT} disable	Clear fault by disconnecting IN or cycling (high / low) TS/BAT_EN		1		ms
I _{OUT_CL}	Maximum I _{OUT} current limit regulation (Clamp)	V _{IN} = 5 V; V _{OUT} = 3.6 V; R _{ISET} : 540 Ω → 250 Ω; I _{OUT} latches off after t _{DGL_SHORT}	550	600	650	mA
BATTERY SHORT PROTECTION						
V _{OUT(SC)}	OUT pin short-circuit detection threshold/ precharge threshold	V _{OUT} : 3 V → 0.5 V; No deglintch	0.75	0.8	0.85	V
V _{OUT(SC-HYS)}	OUT pin Short hysteresis	Recovery ≥ V _{OUT(SC)} + V _{OUT(SC-HYS)} ; Rising; No deglintch		77		mV
I _{OUT(SC)}	Source current to OUT pin during short-circuit detection		9	11	13	mA
QUIESCENT CURRENT						
I _{OUT(PDWN)}	Battery current into OUT pin	V _{IN} = 0 V; 0°C to 125°C			80	nA
		V _{IN} = 0 V; 0°C to 85°C			50	
I _{OUT(DONE)}	OUT pin current, charging terminated	V _{IN} = 6 V; V _{OUT} > V _{OUT(REG)}			6	μA
I _{IN(STDBY)}	Standby current into IN pin	TS = GND; V _{IN} ≤ 6 V			125	μA
I _{CC}	Active supply current, IN pin	TS = open, V _{IN} = 6 V; TTDM – no load on OUT pin; V _{OUT} > V _{OUT(REG)} ; IC enabled		0.75	1	mA

Electrical Characteristics (continued)

 Over junction temperature range $-5^{\circ}\text{C} \leq T_J \leq 125^{\circ}\text{C}$ and recommended supply voltage (unless otherwise noted)

PARAMETER		TEST CONDITIONS	MIN	TYP	MAX	UNIT
BATTERY CHARGER FAST-CHARGE						
$V_{\text{OUT(REG)}}$	Output voltage	$T_J = -5^{\circ}\text{C}$ to 125°C ; $I_{\text{OUT}} = 0$ mA to 250 mA; $V_{\text{IN}} = 5.0$ V; $V_{\text{TS-45}^{\circ}\text{C}} \leq V_{\text{TS}} \leq V_{\text{TS-0}^{\circ}\text{C}}$ (bq25100B)	4.25	4.284	4.305	V
		$T_J = -5^{\circ}\text{C}$ to 55°C ; $I_{\text{OUT}} = 10$ mA to 75 mA; $V_{\text{IN}} = 5.0$ V; $V_{\text{TS-45}^{\circ}\text{C}} \leq V_{\text{TS}} \leq V_{\text{TS-0}^{\circ}\text{C}}$ (bq25100B)	4.266	4.284	4.305	
$I_{\text{OUT(RANGE)}}$	Programmed output "fast charge" current range	$V_{\text{OUT(REG)}} > V_{\text{OUT}} > V_{\text{LOWV}}$; $V_{\text{IN}} = 5$ V; $R_{\text{ISET}} = 0.54$ k Ω to 13.5 k Ω	10		250	mA
$V_{\text{DO(IN-OUT)}}$	Drop-Out, $V_{\text{IN}} - V_{\text{OUT}}$	Adjust V_{IN} down until $I_{\text{OUT}} = 0.2$ A; $V_{\text{OUT}} = 4.15$ V; $R_{\text{ISET}} = 680$ Ω ; $T_J \leq 100^{\circ}\text{C}$		240	400	mV
I_{OUT}	Output "fast charge" formula	$V_{\text{OUT(REG)}} > V_{\text{OUT}} > V_{\text{LOWV}}$; $V_{\text{IN}} = 5$ V		$K_{\text{ISET}}/R_{\text{ISET}}$		A
K_{ISET}	Fast charge current factor	$R_{\text{ISET}} = K_{\text{ISET}}/I_{\text{OUT}}$; $20 < I_{\text{OUT}} < 250$ mA	129	135	145	A Ω
		$R_{\text{ISET}} = K_{\text{ISET}}/I_{\text{OUT}}$; $5 < I_{\text{OUT}} < 20$ mA	125	135	145	
PRECHARGE – SET BY PRETERM PIN						
V_{LOWV}	Pre-charge to fast-charge transition threshold		2.4	2.5	2.6	V
$t_{\text{DGL1(LOWV)}}$	Deglitch time on pre-charge to fast-charge transition			57		μs
$t_{\text{DGL2(LOWV)}}$	Deglitch time on fast-charge to pre-charge transition			32		ms
$I_{\text{PRE-TERM}}$	Refer to the Termination Section					
$\%_{\text{PRECHG}}$	Pre-charge current, default setting	$V_{\text{OUT}} < V_{\text{LOWV}}$; $R_{\text{ISET}} = 2.7$ k Ω ; $R_{\text{PRE-TERM}} = \text{High Z}$ or for bq25101/101H	18	20	22	% $I_{\text{OUT-CC}}$
	Pre-charge current formula	$R_{\text{PRE-TERM}} = K_{\text{PRE-CHG}} (\Omega/\%) \times \%_{\text{PRE-CHG}} (\%)$		$R_{\text{PRE-TERM}}/K_{\text{PRE-CHG}}$		
$K_{\text{PRE-CHG}}$	% Pre-charge Factor	$V_{\text{OUT}} < V_{\text{LOWV}}$; $V_{\text{IN}} = 5$ V; $R_{\text{PRE-TERM}} = 6$ k Ω to 30 k Ω ; $R_{\text{ISET}} = 1.8$ k Ω ; $R_{\text{PRE-TERM}} = K_{\text{PRE-CHG}} \times \%I_{\text{PRE-CHG}}$, where $\%I_{\text{PRE-CHG}}$ is 20 to 100%	280	300	320	$\Omega/\%$
		$V_{\text{OUT}} < V_{\text{LOWV}}$; $V_{\text{IN}} = 5$ V; $R_{\text{PRE-TERM}} = 3$ k Ω to 6 k Ω ; $R_{\text{ISET}} = 1.8$ k Ω ; $R_{\text{PRE-TERM}} = K_{\text{PRE-CHG}} \times \%I_{\text{PRE-CHG}}$, where $\%I_{\text{PRE-CHG}}$ is 10% to 20%	265	305	347	
TERMINATION – SET BY PRE-TERM PIN						
$\%_{\text{TERM}}$	Termination threshold current, default setting	$V_{\text{OUT}} > V_{\text{RCH}}$; $R_{\text{ISET}} = 2.7$ k Ω ; $R_{\text{PRE-TERM}} = \text{High Z}$ or for bq25101/101H	9	10	11	% $I_{\text{OUT-CC}}$
	Termination current threshold formula	$R_{\text{PRE-TERM}} = K_{\text{TERM}} (\Omega/\%) \times \%_{\text{TERM}} (\%)$		$R_{\text{PRE-TERM}}/K_{\text{TERM}}$		
K_{TERM}	% Term factor	$V_{\text{OUT}} > V_{\text{RCH}}$; $V_{\text{IN}} = 5$ V; $R_{\text{PRE-TERM}} = 6$ k Ω to 30 k Ω ; $R_{\text{ISET}} = 1.8$ k Ω ; $R_{\text{PRE-TERM}} = K_{\text{TERM}} \times \%I_{\text{TERM}}$, where $\%I_{\text{TERM}}$ is 10 to 50%	575	600	640	$\Omega/\%$
		$V_{\text{OUT}} > V_{\text{RCH}}$; $V_{\text{IN}} = 5$ V; $R_{\text{PRE-TERM}} = 3$ k Ω to 6 k Ω ; $R_{\text{ISET}} = 1.8$ k Ω ; $R_{\text{PRE-TERM}} = K_{\text{TERM}} \times \%I_{\text{TERM}}$, where $\%I_{\text{TERM}}$ is 5 to 10%	555	620	685	
		$V_{\text{OUT}} > V_{\text{RCH}}$; $V_{\text{IN}} = 5$ V; $R_{\text{PRE-TERM}} = 750$ Ω to 3 k Ω ; $R_{\text{ISET}} = 1.8$ k Ω ; $R_{\text{PRE-TERM}} = K_{\text{TERM}} \times \%I_{\text{TERM}}$, where $\%I_{\text{TERM}}$ is 1.25% to 5%	352	680	1001	
$I_{\text{PRE-TERM}}$	Current for programming the term. and pre-chg with resistor, $I_{\text{Term-Start}}$ is the initial PRE-TERM current	$R_{\text{PRE-TERM}} = 6$ k Ω ; $V_{\text{OUT}} = 4.15$ V	23	25	27	μA
I_{TERM}	Termination current range	Minimum absolute termination current	1			mA
$\%_{\text{TERM}}$	Termination current formula			$R_{\text{TERM}}/K_{\text{TERM}}$		%
$t_{\text{DGL(TERM)}}$	Deglitch time, termination detected			29		ms
RECHARGE OR REFRESH						
V_{RCH}	Recharge detection threshold – normal temp	$V_{\text{IN}} = 5$ V; $V_{\text{TS}} = 0.5$ V; $V_{\text{OUT}}: 4.35$ V \rightarrow V_{RCH}	$V_{\text{O(REG)}} - 0.125$	$V_{\text{O(REG)}} - 0.01$	$V_{\text{O(REG)}} - 0.075$	V

Electrical Characteristics (continued)

Over junction temperature range $-5^{\circ}\text{C} \leq T_J \leq 125^{\circ}\text{C}$ and recommended supply voltage (unless otherwise noted)

PARAMETER		TEST CONDITIONS	MIN	TYP	MAX	UNIT
$t_{DGL1(RCH)}$	Deglitch time, recharge threshold detected	$V_{IN} = 5\text{ V}$; $V_{TS} = 0.5\text{ V}$; $V_{OUT} = 4.25\text{ V} \rightarrow 3.5\text{ V}$ in 1 μs ; $t_{DGL(RCH)}$ is time to ISET ramp		29		ms
$t_{DGL2(RCH)}$	Deglitch time, recharge threshold detected in OUT-Detect Mode	$V_{IN} = 5\text{ V}$; $V_{TS} = 0.5\text{ V}$; $V_{OUT} = 3.5\text{ V}$ inserted; $t_{DGL(RCH)}$ is time to ISET ramp		29		ms
BATTERY DETECT ROUTINE – (NOTE: In Hot mode $V_{O(REG)}$ becomes $V_{O-HT(REG)}$)						
V_{REG-BD}	V_{OUT} reduced regulation during battery detect	$V_{IN} = 5\text{ V}$; $V_{TS} = 0.5\text{ V}$; Battery absent	$V_{O(REG)}^-$ 0.550	$V_{O(REG)}^-$ 0.500	$V_{O(REG)}^-$ 0.450	V
$I_{BD-SINK}$	Sink current during V_{REG-BD}	$V_{IN} = 5\text{ V}$; $V_{TS} = 0.5\text{ V}$; Battery absent		2		mA
$t_{DGL(HI/LOW REG)}$	Regulation time at V_{REG} or V_{REG-BD}	$V_{IN} = 5\text{ V}$; $V_{TS} = 0.5\text{ V}$; Battery absent		25		ms
V_{BD-HI}	High battery detection threshold	$V_{IN} = 5\text{ V}$; $V_{TS} = 0.5\text{ V}$; Battery absent	$V_{O(REG)}^-$ 0.150	$V_{O(REG)}^-$ 0.100	$V_{O(REG)}^-$ 0.050	V
V_{BD-LO}	Low battery detection threshold	$V_{IN} = 5\text{ V}$; $V_{TS} = 0.5\text{ V}$; Battery absent	V_{REG-BD} +0.05	V_{REG-BD} +0.1	V_{REG-BD} +0.15	V
BATTERY CHARGING TIMERS AND FAULT TIMERS						
t_{PRECHG}	Pre-charge safety timer value	Restarts when entering pre-charge; Always enabled when in pre-charge.	1700	1940	2250	s
t_{MAXCH}	Charge safety timer value	Clears fault or resets at UVLO, TS disable, OUT Short, exiting LOWV and Refresh	34000	38800	45000	s
BATTERY-PACK NTC MONITOR (see Note 1); TS pin: 10k NTC						
$I_{NTC-10k}$	NTC bias current	$V_{TS} = 0.3\text{ V}$	48.5	50.5	52.5	μA
$I_{NTC-DIS-10k}$	10k NTC bias current when charging is disabled	$V_{TS} = 0\text{ V}$	27	30	33	μA
$I_{NTC-FLDBK-10k}$	INTC is reduced prior to entering TTDM to keep cold thermistor from entering TTDM	V_{TS} : Set to 1.525 V	4	5	6.5	μA
$V_{TTDM(TS)}$	Termination and timer disable mode Threshold – Enter	V_{TS} : 0.5 V \rightarrow 1.7 V; Timer held in reset	1550	1600	1650	mV
$V_{HYS-TTDM(TS)}$	Hysteresis exiting TTDM	V_{TS} : 1.7 V \rightarrow 0.5 V; Timer enabled		100		mV
$V_{CLAMP(TS)}$	TS maximum voltage clamp	$V_{TS} = \text{Open (float)}$	1900	1950	2000	mV
$t_{DGL(TTDM)}$	Deglitch exit TTDM between states			57		ms
	Deglitch enter TTDM between states			8		μs
$V_{TS-I-FLDBK}$	TS voltage where INTC is reduce to keep thermistor from entering TTDM	INTC adjustment (90 to 10%; 45 to 6.6 μA) takes place near this spec threshold; V_{TS} : 1.425 V \rightarrow 1.525 V		1475		mV
C_{TS}	Optional capacitance – ESD			0.22		μF
$V_{TS-0^{\circ}\text{C}}$	Low temperature, charge pending	Low temperature charging to pending; V_{TS} : 1 V \rightarrow 1.5 V	1230	1255	1280	mV
$V_{HYS-0^{\circ}\text{C}}$	Hysteresis	At 0 $^{\circ}\text{C}$; Charge pending to low temperature charging; V_{TS} : 1.5 V \rightarrow 1 V		100		mV
$V_{TS-10^{\circ}\text{C}}$	Low temperature, half charge	Normal charging to low temperature charging; V_{TS} : 0.5 V \rightarrow 1 V	775	800	830	mV
$V_{HYS-10^{\circ}\text{C}}$	Hysteresis	At 10 $^{\circ}\text{C}$; Low temperature charging to normal charging; V_{TS} : 1 V \rightarrow 0.5 V		55		mV
$V_{TS-45^{\circ}\text{C}}$	High temperature	At 4.1 V (bq25100/101) or 4.2 V (bq25100H/101H); Normal charging to high temperature charging; V_{TS} : 0.5 V \rightarrow 0.2 V	253	268	283	mV
$V_{HYS-45^{\circ}\text{C}}$	Hysteresis	At 45 $^{\circ}\text{C}$; High temperature charging to normal charging; V_{TS} : 0.2 V \rightarrow 0.5 V		20		mV
$V_{TS-60^{\circ}\text{C}}$	High temperature disable	bq25100/01/100H/101H/100L; High temperature charge to pending; V_{TS} : 0.2 V \rightarrow 0.1 V	160	170	180	mV

Electrical Characteristics (continued)

 Over junction temperature range $-5^{\circ}\text{C} \leq T_J \leq 125^{\circ}\text{C}$ and recommended supply voltage (unless otherwise noted)

PARAMETER		TEST CONDITIONS	MIN	TYP	MAX	UNIT
$V_{\text{HYS-60}^{\circ}\text{C}}$	Hysteresis	At 60°C (bq25100/01/100H/101H/100L); Charge pending to high temperature charging; $V_{\text{TS}}: 0.1\text{ V} \rightarrow 0.2\text{ V}$		20		mV
$t_{\text{DGL(TS_10C)}}$	Deglitch for TS thresholds: 10C	Normal to cold operation; $V_{\text{TS}}: 0.6\text{ V} \rightarrow 1\text{ V}$		50		ms
		Cold to normal operation; $V_{\text{TS}}: 1\text{ V} \rightarrow 0.6\text{ V}$		12		
$t_{\text{DGL(TS)}}$	Deglitch for TS thresholds: 0/45/60C	Battery charging		30		ms
$V_{\text{TS-EN-10k}}$	Charge enable threshold, (10k NTC)	$V_{\text{TS}}: 0\text{ V} \rightarrow 0.175\text{ V}$	84	92	100	mV
$V_{\text{TS-DIS_HYS-10k}}$	HYS below $V_{\text{TS-EN-10k}}$ to disable, (10k NTC)	$V_{\text{TS}}: 0.125\text{ V} \rightarrow 0\text{ V}$		12		mV
THERMAL REGULATION						
$T_{\text{J(REG)}}$	Temperature regulation limit			125		°C
$T_{\text{J(OFF)}}$	Thermal shutdown temperature			155		°C
$T_{\text{J(OFF-HYS)}}$	Thermal shutdown hysteresis			20		°C
LOGIC LEVELS ON /CHG						
V_{OL}	Output low voltage	$I_{\text{SINK}} = 5\text{ mA}$			0.4	V
I_{LEAK}	Leakage current into IC	$V_{\text{CHG}} = 5\text{ V}$			1	μA

7.6 Typical Characteristics

Setup: Typical Applications Schematic; $V_{IN} = 5\text{ V}$, $V_{BAT} = 3.6\text{ V}$ (unless otherwise noted)

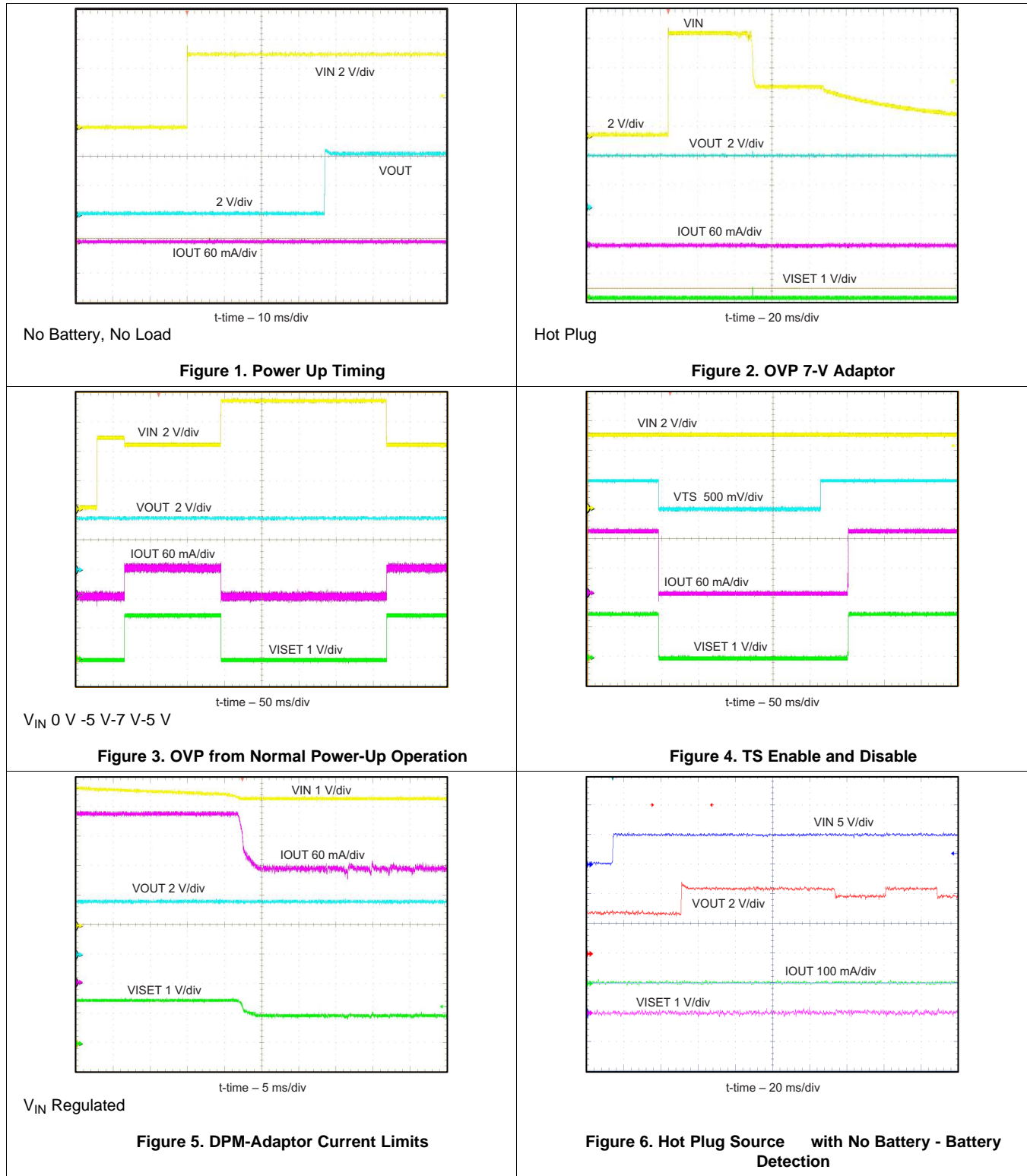

Typical Characteristics (continued)

Setup: Typical Applications Schematic; $V_{IN} = 5\text{ V}$, $V_{BAT} = 3.6\text{ V}$ (unless otherwise noted)

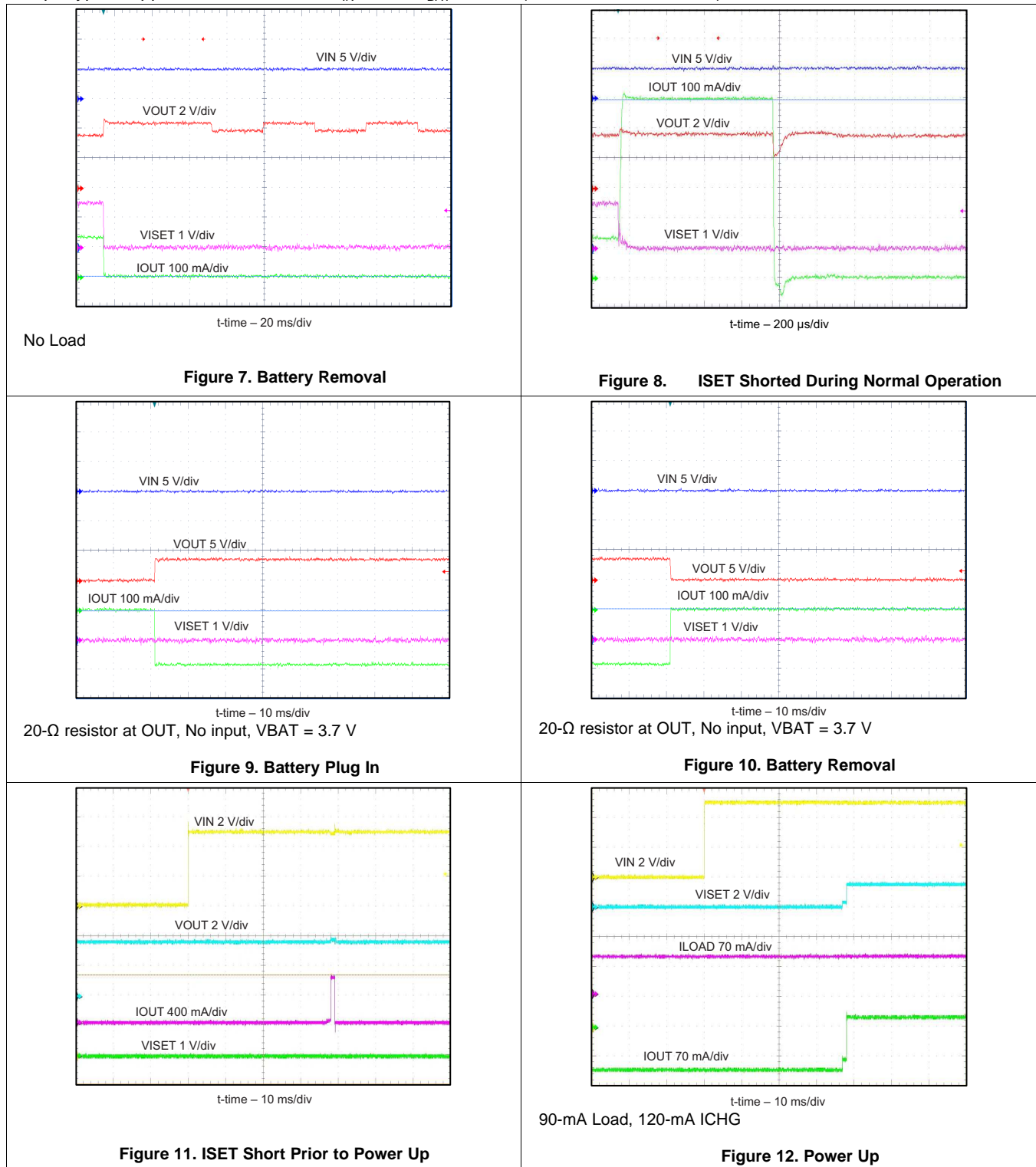

Typical Characteristics (continued)

Setup: Typical Applications Schematic; $V_{IN} = 5\text{ V}$, $V_{BAT} = 3.6\text{ V}$ (unless otherwise noted)

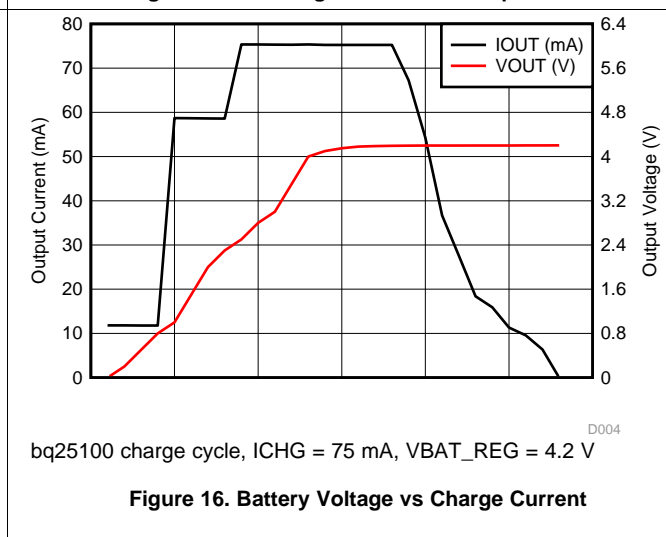
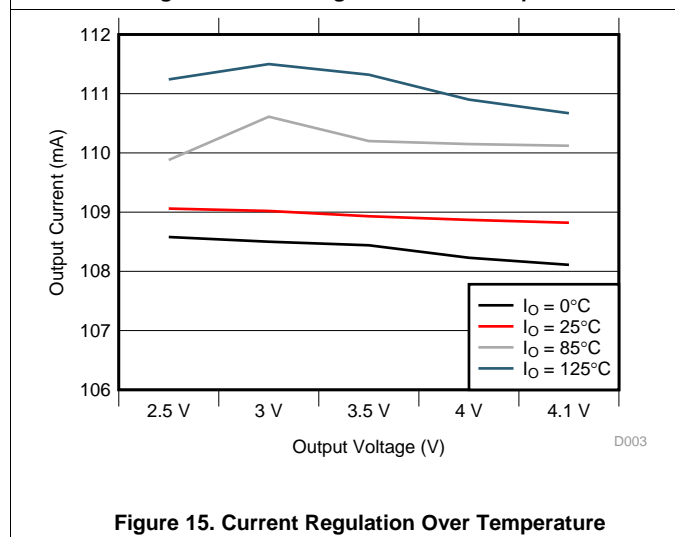
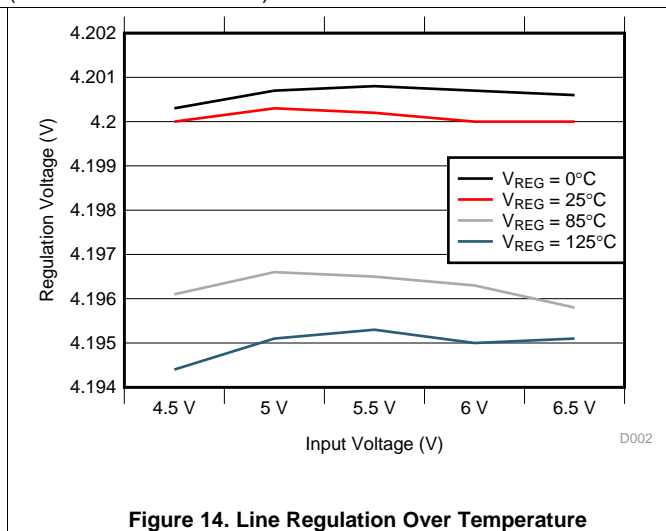
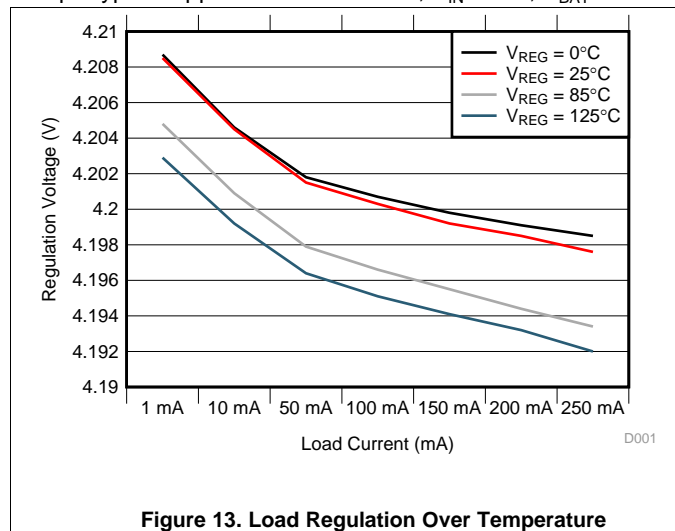

8 Detailed Description

8.1 Overview

The bq25100B is a highly integrated family of single cell Li-Ion and Li-Pol chargers. The charger can be used to charge a battery, power a system or both. The charger has three phases of charging: pre-charge to recover a fully discharged battery, fast-charge constant current to supply the charge safely and voltage regulation to safely reach full capacity. The charger is very flexible, allowing programming of the fast-charge current and Pre-charge/Termination Current. This charger is designed to work with a USB connection (100-mA limit) or Adaptor (DC output). The charger also checks to see if a battery is present. The following discussion reviews all products in the bq25100B family. Not all features apply to the bq25100B.

The charger also comes with a full set of safety features: JEITA Temperature Standard (bq25100/01/100H/101H), Over-Voltage Protection, DPM-IN, Safety Timers, and ISET short protection. All of these features and more are described in detail below.

The charger is designed for a single power path from the input to the output to charge a single cell Li-Ion or Li-Pol battery pack. Upon application of a 5-V DC power source the ISET and OUT short checks are performed to assure a proper charge cycle.

If the battery voltage is below the LOWV threshold, the battery is considered discharged and a preconditioning cycle begins. The amount of precharge current can be programmed using the PRE-TERM pin which programs a percent of fast charge current (10 to 100%) as the precharge current. This feature is useful when the system load is connected across the battery “stealing” the battery current. The precharge current can be set higher to account for the system loading while allowing the battery to be properly conditioned. The PRE-TERM pin is a dual function pin which sets the precharge current level and the termination threshold level. The termination “current threshold” is always half of the precharge programmed current level.

Once the battery voltage has charged to the VLOWV threshold, fast charge is initiated and the fast charge current is applied. The fast charge constant current is programmed using the ISET pin. The constant current provides the bulk of the charge. Power dissipation in the IC is greatest in fast charge with a lower battery voltage. If the IC reaches 125°C, the IC enters thermal regulation, slows the timer clock by half, and reduces the charge current as needed to keep the temperature from rising any further. [Figure 17](#) shows the charging profile with thermal regulation. Typically under normal operating conditions, the IC’s junction temperature is less than 125°C and thermal regulation is not entered.

Once the cell has charged to the regulation voltage the voltage loop takes control and holds the battery at the regulation voltage until the current tapers to the termination threshold. The termination can be disabled if desired.

Further details are described in the Operating Modes section.

Overview (continued)

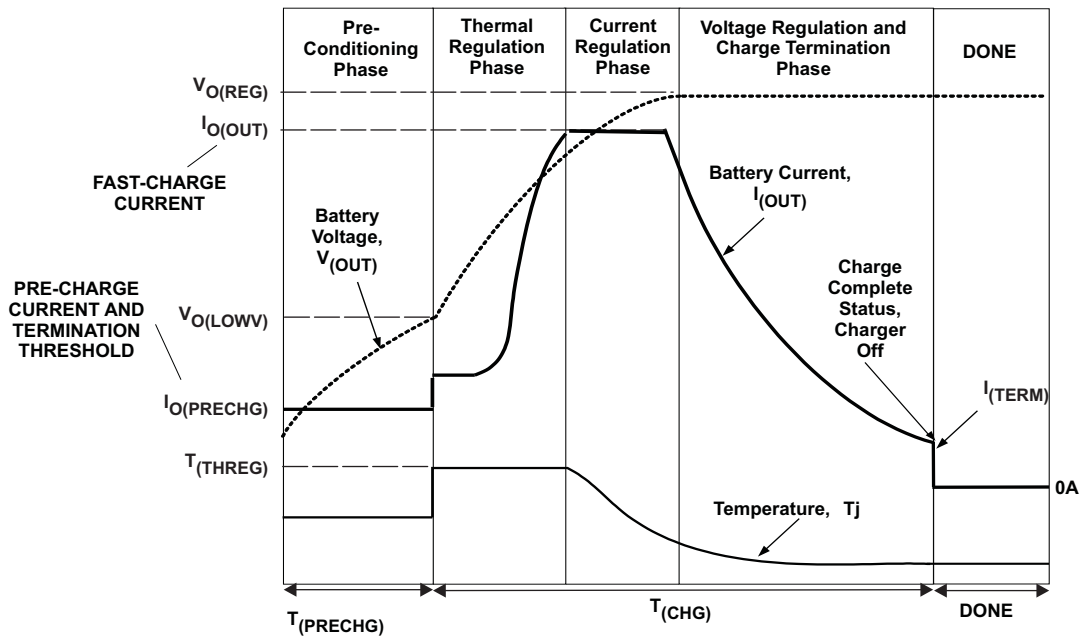
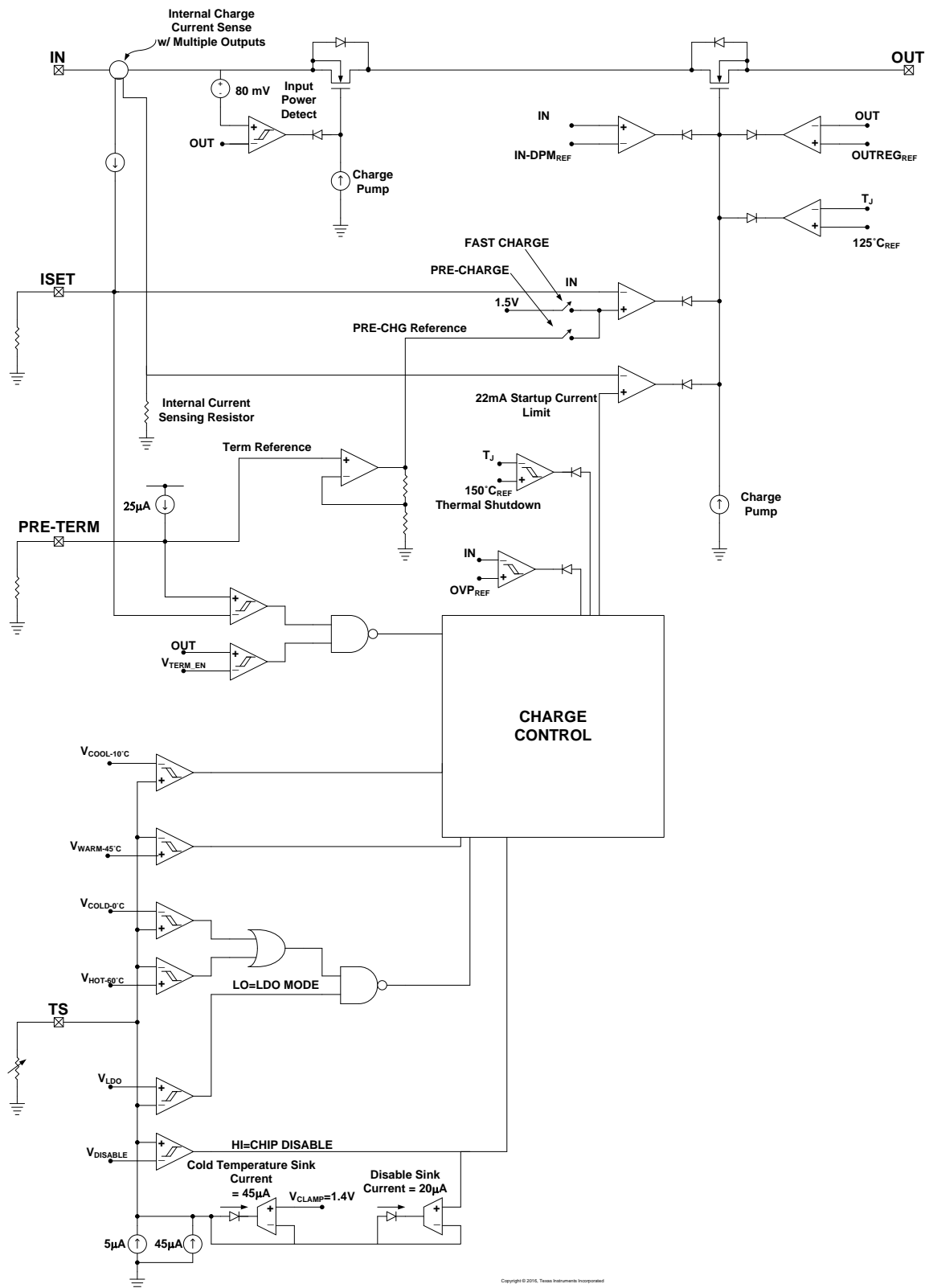

Figure 17. Charging Profile With Thermal Regulation

8.2 Functional Block Diagram



8.3 Feature Description

8.3.1 Overvoltage-Protection (OVP) – Continuously Monitored

If the input source applies an overvoltage, the pass FET, if previously on, turns off after a deglitch, $t_{BLK(OVP)}$. The timer stops counting. Once the overvoltage returns to a normal voltage, the timer and charge continues.

8.3.2 \overline{CHG} Pin Indication (bq25101, bq25101H)

The charge pin has an internal open drain FET which is on (pulls down to VSS) during the first charge only (independent of TTDM) and is turned off once the battery reaches voltage regulation and the charge current tapers to the termination threshold set by the PRE-TERM resistor. The bq25101/01H terminates at 10% of the programmed charge current. The charge pin is high impedance in sleep mode and OVP and returns to its previous state once the condition is removed. Cycling input power, removing and replacing the battery, pulling the TS pin low and releasing or entering pre-charge mode causes the \overline{CHG} pin to go reset (go low if power is good and a discharged battery is attached) and is considered the start of a first charge.

8.3.3 \overline{CHG} Pin LED Pull-up Source (bq25101, bq25101H)

For host monitoring, a pull-up resistor is used between the \overline{CHG} pin and the VCC of the host and for a visual indication a resistor in series with an LED is connected between the \overline{CHG} pin and a power source. If the CHG source is capable of exceeding 7 V, a 6.2-V zener should be used to clamp the voltage. If the source is the OUT pin, note that as the battery changes voltage, and the brightness of the LEDs vary.

8.3.4 IN-DPM (V_{IN-DPM} or IN-DPM)

The IN-DPM feature is used to detect an input source voltage that is folding back (voltage dropping), reaching its current limit due to excessive load. When the input voltage drops to the V_{IN-DPM} threshold the internal pass FET starts to reduce the current until there is no further drop in voltage at the input. This would prevent a source with voltage less than V_{IN-DPM} to power the out pin. This is an added safety feature that helps protect the source from excessive loads. This feature is not applicable for bq25100B.

8.3.5 OUT

The Charger's OUT pin provides current to the battery and to the system, if present. This IC can be used to charge the battery plus power the system, charge just the battery or just power the system (TTDM) assuming the loads do not exceed the available current. The OUT pin is a current limited source and is inherently protected against shorts. If the system load ever exceeds the output programmed current threshold, the output will be discharged unless there is sufficient capacitance or a charged battery present to supplement the excessive load.

8.3.6 ISET

An external resistor is used to Program the Output Current (10 to 250 mA) and can be used as a current monitor.

$$R_{ISET} = K_{ISET} \div I_{OUT} \quad (1)$$

Where:

- I_{OUT} is the desired fast charge current;
- K_{ISET} is a gain factor found in the electrical specification

For greater accuracy at lower currents, part of the sense FET is disabled to give better resolution. Going from higher currents to low currents, there is hysteresis and the transition occurs around 50 mA.

The ISET resistor is short protected and will detect a resistance lower than $\approx 420 \Omega$. The detection requires at least 50 mA of output current. If a "short" is detected, then the IC will latch off and can be reset by cycling the power or cycling TS pin. The OUT current is internally clamped to a maximum current of 600 mA typical and is independent of the ISET short detection circuitry.

For charge current that is below 50 mA, an extra RC circuit is recommended on ISET to achieve more stable current signal. More detail is available in 9.1 Application Information.

Feature Description (continued)

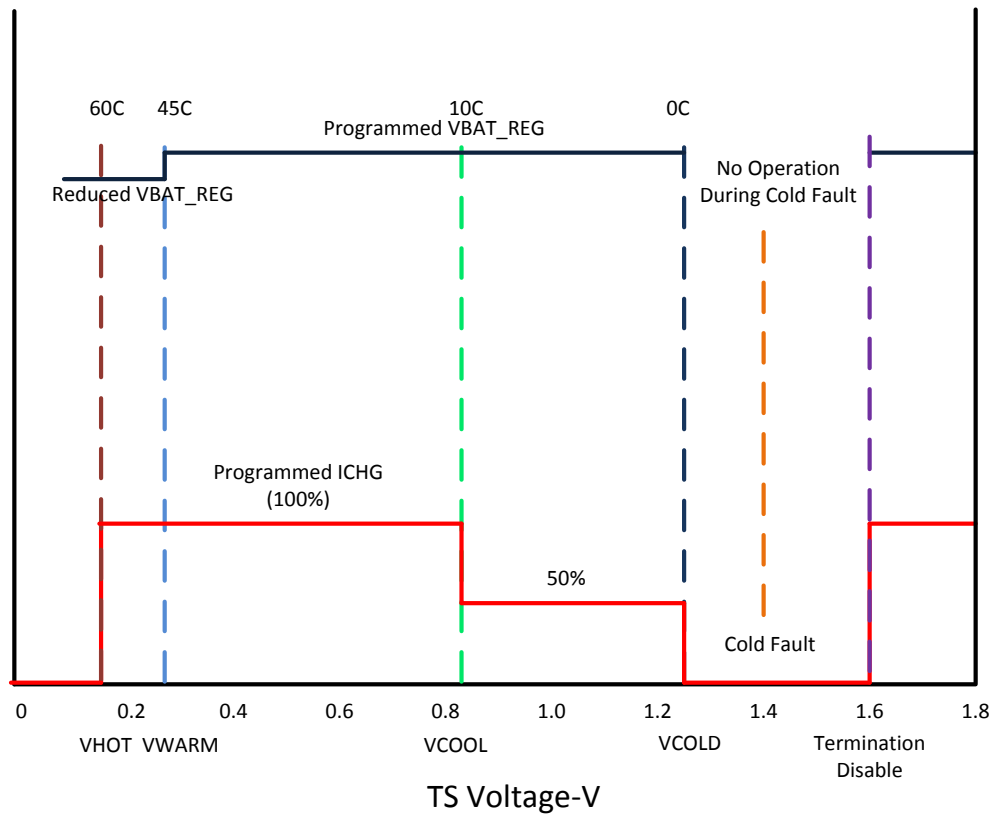

Figure 18. JEITA Operation Over TS Bias Voltage - bq25100, bq25100H, bq25101, bq25101H

Feature Description (continued)

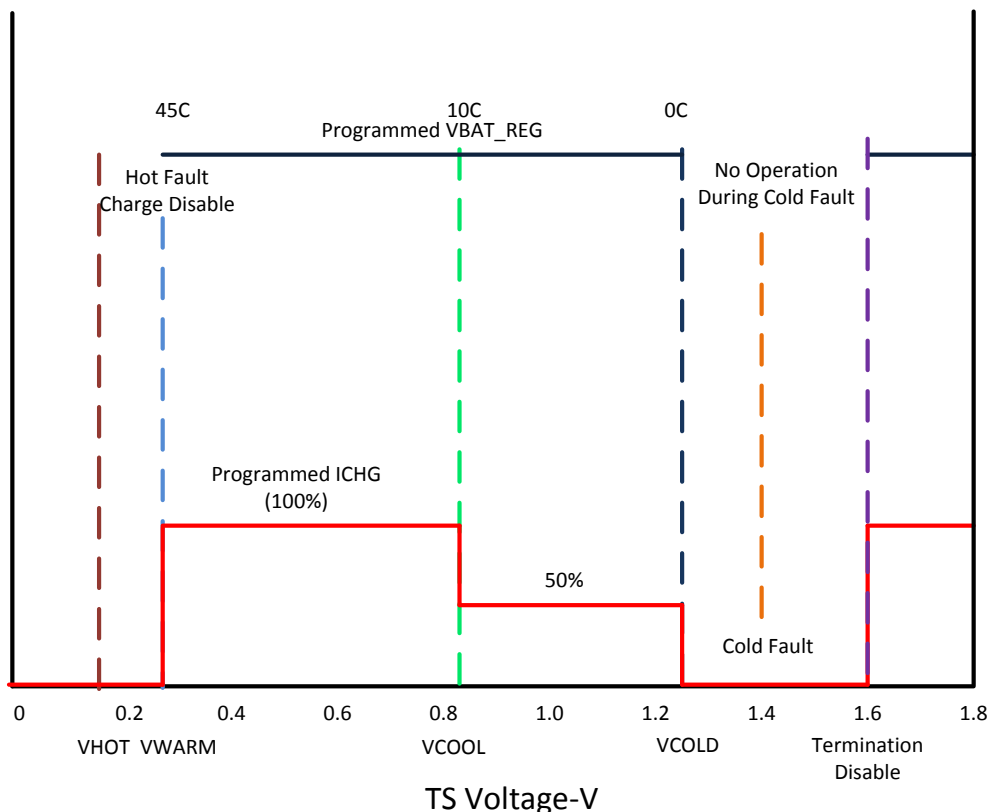

Figure 19. Standard Operation Over TS Bias Voltage – bq25100B, bq25100A, bq25100L

8.3.7 PRE_TERM – Pre-Charge and Termination Programmable Threshold

Pre-Term is used to program both the pre-charge current and the termination current threshold. The pre-charge current level is a factor of two higher than the termination current level. The termination can be set between 5 and 50% (recommended range) of the programmed output current level set by ISET. If left floating the termination and pre-charge are set internally at 10/20% respectively. The R_{PRE-TERM} is ranged from 600 Ω to 30 kΩ and the minimum termination current can be programmed to 1 mA. The pre-charge-to-fast-charge, V_{lowv} threshold is set to 2.5 V.

$$R_{PRE-TERM} = \%Term \times K_{TERM} = \%Pre-CHG \times K_{PRE-CHG} \tag{2}$$

Where:

- %Term is the percent of fast charge current where termination occurs;
- %Pre-CHG is the percent of fast charge current that is desired during precharge;
- K_{TERM} and K_{PRE-CHG} are gain factors found in the electrical specifications.

8.3.8 TS

The TS function for the bq25100B/bq25100A cuts the charge current level in half between 0°C and 10°C and disables charging when the NTC temperature is above 45°C. The TS function for the bq25100/bq25100H/bq25101/bq25101H is designed to follow the new JEITA temperature standard for Li-Ion and Li-Pol batteries. There are now four thresholds, 60°C, 45°C, 10°C, and 0°C. Normal operation occurs between 10°C and 45°C. If between 0°C and 10°C the charge current level is cut in half and if between 45°C and 60°C the regulation voltage is reduced to 4.1 V max for bq25100 and 4.2 V max for bq25100H, see Figure 18.

Feature Description (continued)

The TS feature is implemented using an internal 50 μ A current source to bias the thermistor (designed for use with a 10-k NTC $\beta = 3370$ (SEMITEC 103AT-2 or Mitsubishi TH05-3H103F) connected from the TS pin to V_{SS} . If this feature is not needed, a fixed 10-k can be placed between TS and V_{SS} to allow normal operation. This may be done if the host is monitoring the thermistor and then the host would determine when to pull the TS pin low to disable charge.

The TS pin has two additional features, when the TS pin is pulled low or floated/driven high. A low disables charge and a high puts the charger in TTDM.

Above 45°C (60°C for bq25100/bq25100H/bq25101/bq25101H) or below 0°C the charge is disabled. Once the thermistor reaches $\pm 10^\circ\text{C}$ the TS current folds back to keep a cold thermistor (between -10°C and -50°C) from placing the IC in the TTDM mode. If the TS pin is pulled low into disable mode, the current is reduce to $\approx 30 \mu\text{A}$. Since the I_{TS} current is fixed along with the temperature thresholds, it is not possible to use thermistor values other than the 10-k NTC (at 25°C).

8.3.9 Timers

The pre-charge timer is set to 30 minutes. The pre-charge current, can be programmed to off-set any system load, making sure that the 30 minutes is adequate.

The fast charge timer is fixed at 10 hours and can be increased real time by going into thermal regulation or IN-DPM. The timer clock slows by a factor of 2, resulting in a clock than counts half as fast when in these modes. If either the 30 minute or ten hour timer times out, the charging is terminated and for bq25101/1H the $\overline{\text{CHG}}$ pin goes high impedance if not already in that state. The timer is reset by disabling the IC, cycling power or going into and out of TTDM.

8.3.10 Termination

Once the OUT pin goes above VRCH, (reaches voltage regulation) and the current tapers down to the termination threshold, a battery detect route is run to determine if the battery was removed or the battery is full. If the battery is present, the charge current will terminate. If the battery was removed along with the thermistor, then the TS pin is driven high and the charge enters TTDM. If the battery was removed and the TS pin is held in the active region, then the battery detect routine will continue until a battery is inserted. The termination current can be programmed down to 625 μA , however, the accuracy will reduce accordingly when the termination current is below 1 mA.

8.4 Device Functional Modes

8.4.1 Power-Down or Undervoltage Lockout (UVLO)

The bq25100B family is in power down mode if the IN pin voltage is less than UVLO. The part is considered “dead” and all the pins are high impedance. Once the IN voltage rises above the UVLO threshold the IC will enter Sleep Mode or Active mode depending on the OUT pin (battery) voltage.

8.4.2 Power-up

The IC is alive after the IN voltage ramps above UVLO (see sleep mode), resets all logic and timers, and starts to perform many of the continuous monitoring routines. Typically the input voltage quickly rises through the UVLO and sleep states where the IC declares power good, starts the qualification charge at 22 mA, sets the charge current base on the ISET pin, and starts the safety timer.

8.4.3 Sleep Mode

If the IN pin voltage is between $V_{OUT}+V_{DT}$ and UVLO, the charge current is disabled, the safety timer counting stops (not reset). As the input voltage rises and the charger exits sleep mode, the safety timer continues to count and the charge is enabled. See [Figure 20](#).

8.4.4 New Charge Cycle

A new charge cycle is started when a good power source is applied, performing a chip disable/enable (TS pin), exiting Termination and Timer Disable Mode (TTDM), detecting a battery insertion or the OUT voltage dropping below the VRCH threshold.

Device Functional Modes (continued)

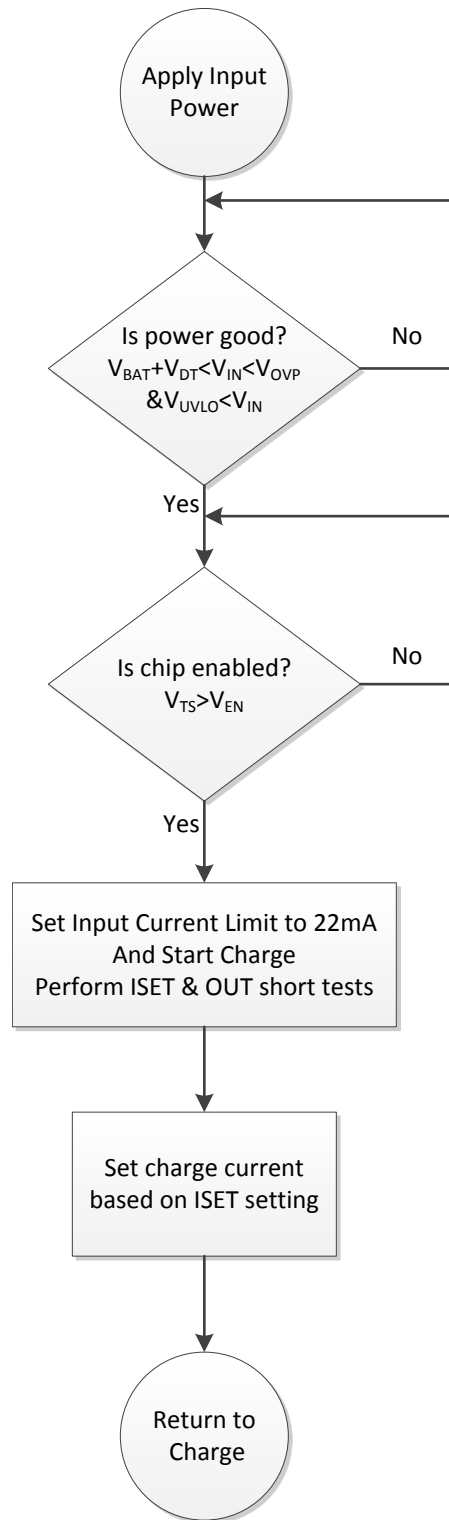

Figure 20. bq25100B Power-Up Flow Diagram

Device Functional Modes (continued)

8.4.5 Termination and Timer Disable Mode (TTDM) - TS Pin High

The battery charger is in TTDM when the TS pin goes high from removing the thermistor (removing battery pack/floating the TS pin) or by pulling the TS pin up to the TTDM threshold.

When entering TTDM, the 10 hour safety timer is held in reset and termination is disabled. A battery detect routine is run to see if the battery was removed or not. For bq25101/1H, if the battery was removed then the $\overline{\text{CHG}}$ pin will go to its high impedance state if not already there. If a battery is detected the $\overline{\text{CHG}}$ pin does not change states until the current tapers to the termination threshold, where the $\overline{\text{CHG}}$ pin goes to its high impedance state if not already there (the regulated output will remain on).

The charging profile does not change (still has pre-charge, fast-charge constant current and constant voltage modes). This implies the battery is still charged safely and the current is allowed to taper to zero.

When coming out of TTDM, the battery detect routine is run and if a battery is detected, then a new charge cycle begins.

If TTDM is not desired upon removing the battery with the thermistor, one can add a 237-k Ω resistor between TS and V_{SS} to disable TTDM. This keeps the current source from driving the TS pin into TTDM. This creates $\pm 0.1^{\circ}\text{C}$ error at hot and a $\pm 3^{\circ}\text{C}$ error at cold.

8.4.6 Battery Detect Routine

The battery detect routine should check for a missing battery while keeping the OUT pin at a useable voltage.

The battery detect routine is run when entering and exiting TTDM to verify if battery is present, or run all the time if battery is missing and not in TTDM. On power-up, if battery voltage is greater than V_{RCH} threshold, a battery detect routine is run to determine if a battery is present.

The battery detect routine is disabled while the IC is in TTDM, or has a TS fault. See [Figure 21](#) for the Battery Detect Flow Diagram.

8.4.7 Refresh Threshold

After termination, if the OUT pin voltage drops to V_{RCH} (100mV below regulation) then a new charge is initiated.

8.4.8 Starting a Charge on a Full Battery

The termination threshold is raised by $\pm 14\%$ for the first minute of a charge cycle so if a full battery is removed and reinserted or a new charge cycle is initiated, that the new charge terminates (less than 1 minute). Batteries that have relaxed many hours may take several minutes to taper to the termination threshold and terminate charge.

Device Functional Modes (continued)

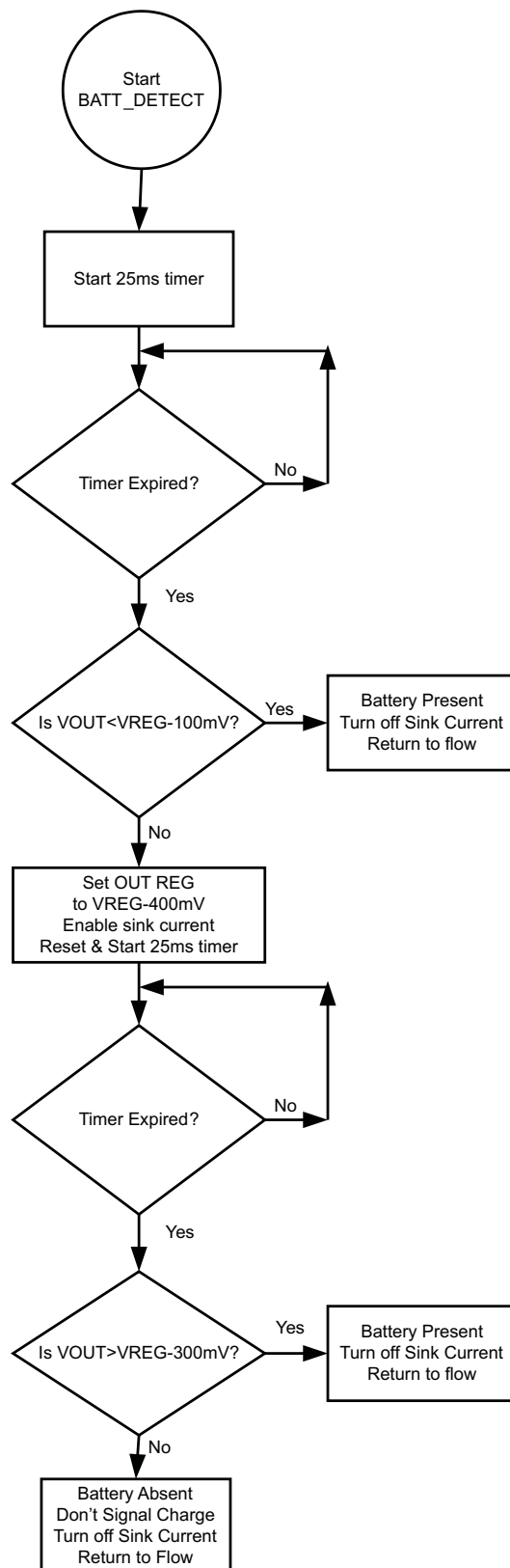

Figure 21. Battery Detect Routine

9 Application and Implementation

NOTE

Information in the following applications sections is not part of the TI component specification, and TI does not warrant its accuracy or completeness. TI's customers are responsible for determining suitability of components for their purposes. Customers should validate and test their design implementation to confirm system functionality.

9.1 Application Information

The bq25100B series of devices are highly integrated Li-Ion and Li-Pol linear chargers targeted at space-limited portable applications. The fast charge current can be programmed from 10 mA to 250 mA through an external resistor on ISET pin. The pre_charge and termination current can also be programmed through the resistor connected on PRETERM pin. The device has complete system-level protection such as input under-voltage lockout (UVLO), input over-voltage protection (OVP), sleep mode, thermal regulation, safety timers, and NTC monitoring input.

9.2 Typical Application

This typical application shows a charger application design example.

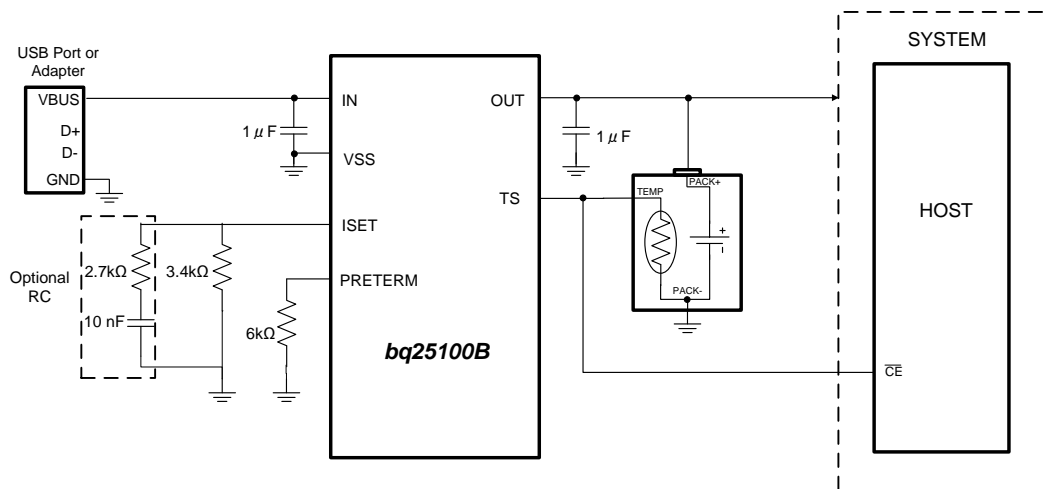

Copyright © 2016, Texas Instruments Incorporated

9.2.1 Design Requirements

- Supply voltage = 5 V
- Fast charge current: $I_{OUT-FC} = 40 \text{ mA}$;
- Termination Current Threshold: $\%I_{OUT-FC} = 10\%$ of Fast Charge or $\sim 4 \text{ mA}$
- Pre-Charge Current by default is twice the termination Current or $\sim 8 \text{ mA}$
- TS – Battery Temperature Sense = 10-k NTC (103AT)
- /CE is an open drain control pin

9.2.2 Detailed Design Procedures

- The regulation voltage is set to 4.2 V, the input voltage is 5 V and the charge current is programmed to 40 mA.
- For charge current that is below 50 mA, an extra RC circuit is recommended on ISET to achieve more stable current signal. For applications that need higher charge current, the RC circuit is not needed.
- For applications that use more than 200-mA current, there could be a very low level $\sim 1\%$ of charge current ringing in the output. The ringing can be removed by increasing the input capacitance.

Typical Application (continued)

9.2.2.1 Calculations

9.2.2.1.1 Program the Fast Charge Current, ISET:

$$R_{ISET} = [K_{(ISET)} / I_{(OUT)}]$$

from electrical characteristics table. . . $K_{(SET)} = 135 \text{ A}\Omega$

$$R_{ISET} = [135 \text{ A}\Omega / 0.04 \text{ A}] = 3.4 \text{ k}\Omega$$

Selecting the closest standard value, use a 3.4-k Ω resistor between ISET and Vss.

9.2.2.1.2 Program the Termination Current Threshold, ITERM:

$$R_{PRE-TERM} = K_{(TERM)} \times \%I_{OUT-FC}$$

$$R_{PRE-TERM} = 600 \text{ }\Omega/\% \times 10\% = 6 \text{ k}\Omega$$

Selecting the closest standard value, use a 6-k Ω resistor between PRETERM and Vss.

One can arrive at the same value by using 20% for a pre-charge value (factor of 2 difference).

$$R_{PRE-TERM} = K_{(PRE-CHG)} \times \%I_{OUT-FC}$$

$$R_{PRE-TERM} = 300 \text{ }\Omega/\% \times 20\% = 6 \text{ k}\Omega$$

9.2.2.1.3 TS Function

Use a 10-k NTC thermistor in the battery pack (103AT).

To Disable the temp sense function, use a fixed 10-k Ω resistor between the TS and VSS.

9.2.2.1.4 Selecting IN and OUT Pin Capacitors

In most applications, all that is needed is a high-frequency decoupling capacitor (ceramic) on the power pin, input and output pins. Using the values shown on the application diagram is recommended. After evaluation of these voltage signals with real system operational conditions, one can determine if capacitance values can be adjusted toward the minimum recommended values (DC load application) or higher values for fast, high amplitude, pulsed load applications. Note if designed for high input voltage sources (bad adaptors or wrong adaptors), the capacitor needs to be rated appropriately. Ceramic capacitors are tested to 2x their rated values so a 16-V capacitor may be adequate for a 30-V transient (verify tested rating with capacitor manufacturer).

9.2.3 bq25100 Application Performance Plots

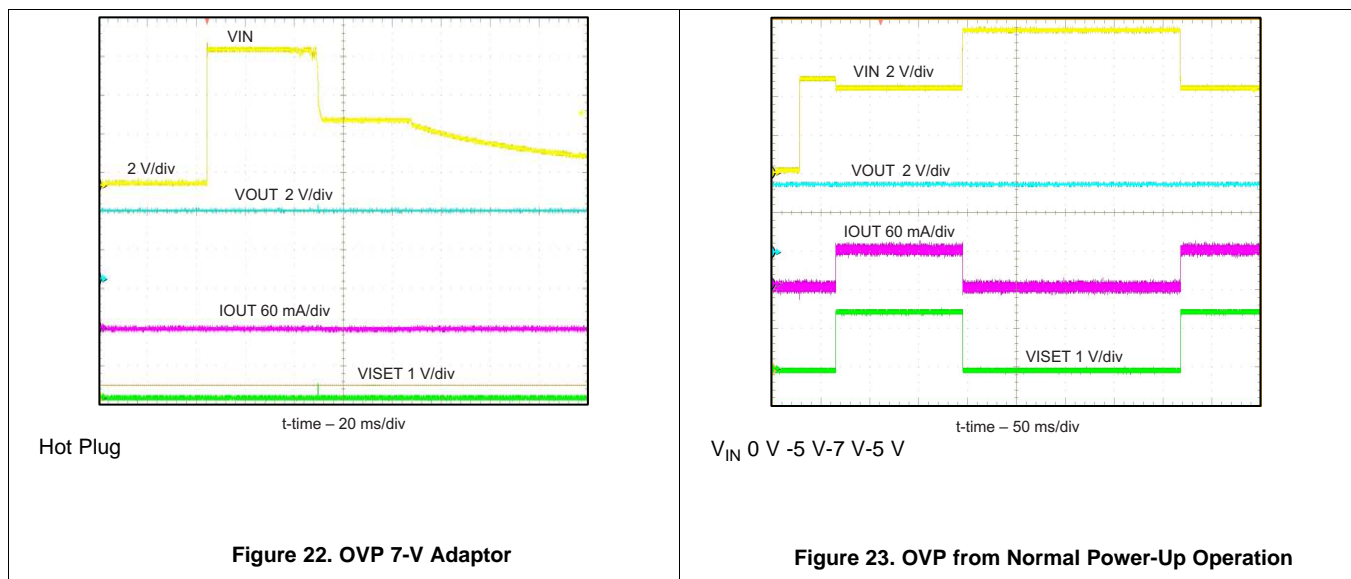

Typical Application (continued)

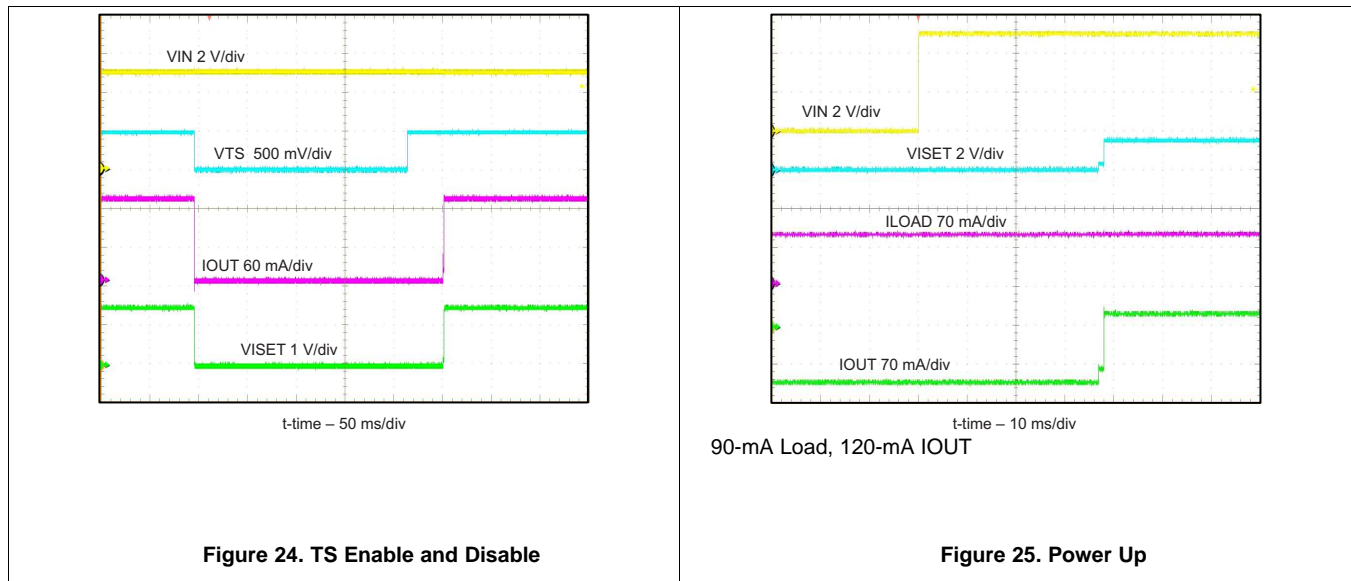

10 Power Supply Recommendations

10.1 Leakage Current Effects on Battery Capacity

To determine how fast a leakage current on the battery will discharge the battery is an easy calculation. The time from full to discharge can be calculated by dividing the Amp-Hour Capacity of the battery by the leakage current. For a 0.1-AHr battery and a 75-nA leakage current ($100 \text{ mAHr} / 75 \text{ nA} = 250000 \text{ Hours}$), it would take 1333k hours or 152 years to discharge. In reality the self discharge of the cell would be much faster so the 75-nA leakage would be considered negligible.

11 Layout

11.1 Layout Guidelines

To obtain optimal performance, the decoupling capacitor from IN to GND and the output filter capacitors from OUT to GND should be placed as close as possible to the bq25100B, with short trace runs to both IN, OUT and GND.

- All low-current GND connections should be kept separate from the high-current charge or discharge paths from the battery. Use a single-point ground technique incorporating both the small signal ground path and the power ground path.
- The high current charge paths into IN pin and from the OUT pin must be sized appropriately for the maximum charge current in order to avoid voltage drops in these traces

11.2 Layout Example

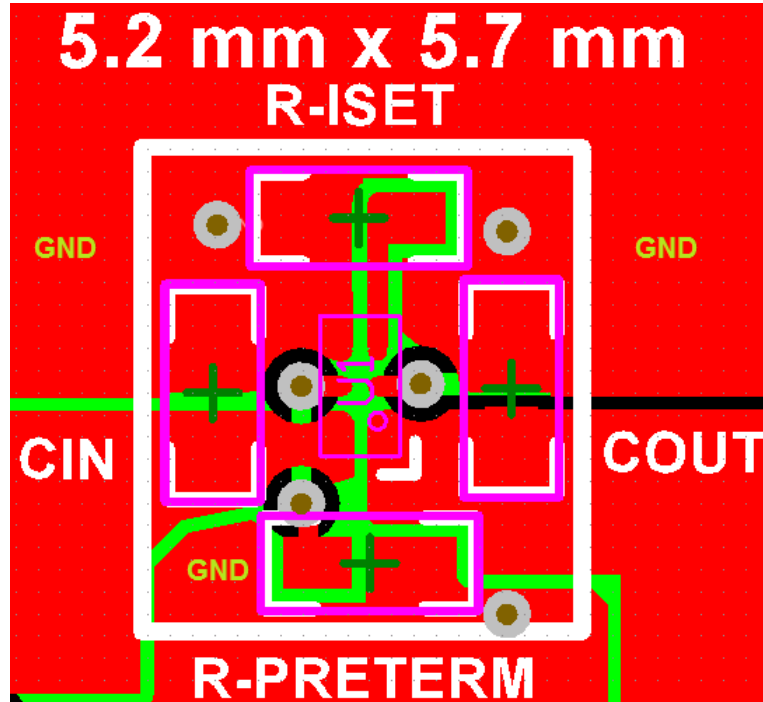

Figure 26. Board Layout

11.3 Thermal Considerations

The most common measure of package thermal performance is thermal impedance (θ_{JA}) measured (or modeled) from the chip junction to the air surrounding the package surface (ambient). The mathematical expression for θ_{JA} is:

$$R_{\theta JA} = (T_J - T_A) / P$$

where

- T_J = chip junction temperature
- T_A = Ambient temperature
- P = device power dissipation

(3)

Factors that can influence the measurement and calculation of $R_{\theta JA}$ include:

1. Whether or not the device is board mounted
2. Trace size, composition, thickness, and geometry
3. Orientation of the device (horizontal or vertical)
4. Volume of the ambient air surrounding the device under test and airflow
5. Whether other surfaces are in close proximity to the device being tested

Due to the charge profile of Li-Ion and Li-Pol batteries the maximum power dissipation is typically seen at the beginning of the charge cycle when the battery voltage is at its lowest. Typically after fast charge begins the pack voltage increases to ≈ 3.4 V within the first 2 minutes. The thermal time constant of the assembly typically takes a few minutes to heat up so when doing maximum power dissipation calculations, 3.4 V is a good minimum voltage to use.

The device power dissipation, P , is a function of the charge rate and the voltage drop across the internal PowerFET. It can be calculated from the following equation when a battery pack is being charged :

$$P = [V_{(IN)} - V_{(OUT)}] \times I_{(OUT)}$$

(4)

Thermal Considerations (continued)

The thermal loop feature reduces the charge current to limit excessive IC junction temperature. It is recommended that the design not run in thermal regulation for typical operating conditions (nominal input voltage and nominal ambient temperatures) and use the feature for non typical situations such as hot environments or higher than normal input source voltage. With that said, the IC will still perform as described, if the thermal loop is always active.

12 器件和文档支持

12.1 器件支持

12.1.1 Third-Party Products Disclaimer

TI'S PUBLICATION OF INFORMATION REGARDING THIRD-PARTY PRODUCTS OR SERVICES DOES NOT CONSTITUTE AN ENDORSEMENT REGARDING THE SUITABILITY OF SUCH PRODUCTS OR SERVICES OR A WARRANTY, REPRESENTATION OR ENDORSEMENT OF SUCH PRODUCTS OR SERVICES, EITHER ALONE OR IN COMBINATION WITH ANY TI PRODUCT OR SERVICE.

12.2 相关链接

下面的表格列出了快速访问链接。范围包括技术文档、支持与社区资源、工具和软件，以及样片或购买的快速访问。

表 1. 相关链接

部件	产品文件夹	样片与购买	技术文档	工具与软件	支持与社区
bq25100	请单击此处	请单击此处	请单击此处	请单击此处	请单击此处
bq25101	请单击此处	请单击此处	请单击此处	请单击此处	请单击此处
bq25100A	请单击此处	请单击此处	请单击此处	请单击此处	请单击此处
bq25100H	请单击此处	请单击此处	请单击此处	请单击此处	请单击此处
bq25101H	请单击此处	请单击此处	请单击此处	请单击此处	请单击此处
bq25100L	请单击此处	请单击此处	请单击此处	请单击此处	请单击此处

12.3 商标

Bluetooth is a registered trademark of Bluetooth SIG, Inc..

12.4 静电放电警告



这些装置包含有限的内置 ESD 保护。存储或装卸时，应将导线一起截短或将装置放置于导电泡棉中，以防止 MOS 门极遭受静电损伤。

12.5 Glossary

[SLYZ022](#) — *TI Glossary*.

This glossary lists and explains terms, acronyms, and definitions.

13 机械、封装和可订购信息

以下页中包括机械、封装和可订购信息。这些信息是针对指定器件可提供的最新数据。这些数据会在无通知且不对本文档进行修订的情况下发生改变。欲获得该数据表的浏览器版本，请查阅左侧的导航栏。

重要声明

德州仪器(TI)及其下属子公司有权根据 JESD46 最新标准,对所提供的产品和服务进行更正、修改、增强、改进或其它更改,并有权根据 JESD48 最新标准中止提供任何产品和服务。客户在下订单前应获取最新的相关信息,并验证这些信息是否完整且是最新的。所有产品的销售都遵循在订单确认时所提供的TI 销售条款与条件。

TI 保证其所销售的组件的性能符合产品销售时 TI 半导体产品销售条件与条款的适用规范。仅在 TI 保证的范围内,且 TI 认为有必要时才会使用测试或其它质量控制技术。除非适用法律做出了硬性规定,否则没有必要对每种组件的所有参数进行测试。

TI 对应用帮助或客户产品设计不承担任何义务。客户应对其使用 TI 组件的产品和应用自行负责。为尽量减小与客户产品和应用相关的风险,客户应提供充分的设计与操作安全措施。

TI 不对任何 TI 专利权、版权、屏蔽作品权或其它与使用了 TI 组件或服务的组合设备、机器或流程相关的 TI 知识产权中授予的直接或隐含权限作出任何保证或解释。TI 所发布的与第三方产品或服务有关的信息,不能构成从 TI 获得使用这些产品或服务的许可、授权、或认可。使用此类信息可能需要获得第三方的专利权或其它知识产权方面的许可,或是 TI 的专利权或其它知识产权方面的许可。

对于 TI 的产品手册或数据表中 TI 信息的重要部分,仅在没有对内容进行任何篡改且带有相关授权、条件、限制和声明的情况下才允许进行复制。TI 对此类篡改过的文件不承担任何责任或义务。复制第三方的信息可能需要服从额外的限制条件。

在转售 TI 组件或服务时,如果对该组件或服务参数的陈述与 TI 标明的参数相比存在差异或虚假成分,则会失去相关 TI 组件或服务的所有明示或暗示授权,且这是不正当的、欺诈性商业行为。TI 对任何此类虚假陈述均不承担任何责任或义务。

客户认可并同意,尽管任何应用相关信息或支持仍可能由 TI 提供,但他们将独立负责满足与其产品及其在应用中使用的 TI 产品相关的所有法律、法规和安全相关要求。客户声明并同意,他们具备制定与实施安全措施所需的全部专业技术和知识,可预见故障的危险后果、监测故障及其后果、降低有可能造成人身伤害的故障的发生机率并采取适当的补救措施。客户将全额赔偿因在此类安全关键应用中使用任何 TI 组件而对 TI 及其代理造成的任何损失。

在某些场合中,为了推进安全相关应用有可能对 TI 组件进行特别的促销。TI 的目标是利用此类组件帮助客户设计和创立其特有的可满足适用的功能安全性标准和要求的终端产品解决方案。尽管如此,此类组件仍然服从这些条款。

TI 组件未获得用于 FDA Class III (或类似的生命攸关医疗设备)的授权许可,除非各方授权官员已经达成了专门管控此类使用的特别协议。

只有那些 TI 特别注明属于军用等级或“增强型塑料”的 TI 组件才是设计或专门用于军事/航空应用或环境的。购买者认可并同意,对并非指定面向军事或航空航天用途的 TI 组件进行军事或航空航天方面的应用,其风险由客户单独承担,并且由客户独立负责满足与此类使用相关的所有法律和法规要求。

TI 已明确指定符合 ISO/TS16949 要求的产品,这些产品主要用于汽车。在任何情况下,因使用非指定产品而无法达到 ISO/TS16949 要求, TI 不承担任何责任。

	产品		应用
数字音频	www.ti.com.cn/audio	通信与电信	www.ti.com.cn/telecom
放大器和线性器件	www.ti.com.cn/amplifiers	计算机及周边	www.ti.com.cn/computer
数据转换器	www.ti.com.cn/dataconverters	消费电子	www.ti.com.cn/consumer-apps
DLP® 产品	www.dlp.com	能源	www.ti.com.cn/energy
DSP - 数字信号处理器	www.ti.com.cn/dsp	工业应用	www.ti.com.cn/industrial
时钟和计时器	www.ti.com.cn/clockandtimers	医疗电子	www.ti.com.cn/medical
接口	www.ti.com.cn/interface	安防应用	www.ti.com.cn/security
逻辑	www.ti.com.cn/logic	汽车电子	www.ti.com.cn/automotive
电源管理	www.ti.com.cn/power	视频和影像	www.ti.com.cn/video
微控制器 (MCU)	www.ti.com.cn/microcontrollers		
RFID 系统	www.ti.com.cn/rfidsys		
OMAP应用处理器	www.ti.com/omap		
无线连通性	www.ti.com.cn/wirelessconnectivity	德州仪器在线技术支持社区	www.deyisupport.com

邮寄地址: 上海市浦东新区世纪大道1568号, 中建大厦32楼邮政编码: 200122
Copyright © 2016, 德州仪器半导体技术(上海)有限公司

PACKAGING INFORMATION

Orderable Device	Status (1)	Package Type	Package Drawing	Pins	Package Qty	Eco Plan (2)	Lead finish/ Ball material (6)	MSL Peak Temp (3)	Op Temp (°C)	Device Marking (4/5)	Samples
BQ25100BYFPR	ACTIVE	DSBGA	YFP	6	3000	RoHS & Green	SNAGCU	Level-1-260C-UNLIM	-5 to 125	25100B	Samples
BQ25100BYFPT	ACTIVE	DSBGA	YFP	6	250	RoHS & Green	SNAGCU	Level-1-260C-UNLIM	-5 to 125	25100B	Samples

(1) The marketing status values are defined as follows:

ACTIVE: Product device recommended for new designs.

LIFEBUY: TI has announced that the device will be discontinued, and a lifetime-buy period is in effect.

NRND: Not recommended for new designs. Device is in production to support existing customers, but TI does not recommend using this part in a new design.

PREVIEW: Device has been announced but is not in production. Samples may or may not be available.

OBSOLETE: TI has discontinued the production of the device.

(2) **RoHS:** TI defines "RoHS" to mean semiconductor products that are compliant with the current EU RoHS requirements for all 10 RoHS substances, including the requirement that RoHS substance do not exceed 0.1% by weight in homogeneous materials. Where designed to be soldered at high temperatures, "RoHS" products are suitable for use in specified lead-free processes. TI may reference these types of products as "Pb-Free".

RoHS Exempt: TI defines "RoHS Exempt" to mean products that contain lead but are compliant with EU RoHS pursuant to a specific EU RoHS exemption.

Green: TI defines "Green" to mean the content of Chlorine (Cl) and Bromine (Br) based flame retardants meet JS709B low halogen requirements of <=1000ppm threshold. Antimony trioxide based flame retardants must also meet the <=1000ppm threshold requirement.

(3) MSL, Peak Temp. - The Moisture Sensitivity Level rating according to the JEDEC industry standard classifications, and peak solder temperature.

(4) There may be additional marking, which relates to the logo, the lot trace code information, or the environmental category on the device.

(5) Multiple Device Markings will be inside parentheses. Only one Device Marking contained in parentheses and separated by a "~" will appear on a device. If a line is indented then it is a continuation of the previous line and the two combined represent the entire Device Marking for that device.

(6) Lead finish/Ball material - Orderable Devices may have multiple material finish options. Finish options are separated by a vertical ruled line. Lead finish/Ball material values may wrap to two lines if the finish value exceeds the maximum column width.

Important Information and Disclaimer:The information provided on this page represents TI's knowledge and belief as of the date that it is provided. TI bases its knowledge and belief on information provided by third parties, and makes no representation or warranty as to the accuracy of such information. Efforts are underway to better integrate information from third parties. TI has taken and continues to take reasonable steps to provide representative and accurate information but may not have conducted destructive testing or chemical analysis on incoming materials and chemicals. TI and TI suppliers consider certain information to be proprietary, and thus CAS numbers and other limited information may not be available for release.

In no event shall TI's liability arising out of such information exceed the total purchase price of the TI part(s) at issue in this document sold by TI to Customer on an annual basis.

YFP0006



PACKAGE OUTLINE

DSBGA - 0.5 mm max height

DIE SIZE BALL GRID ARRAY

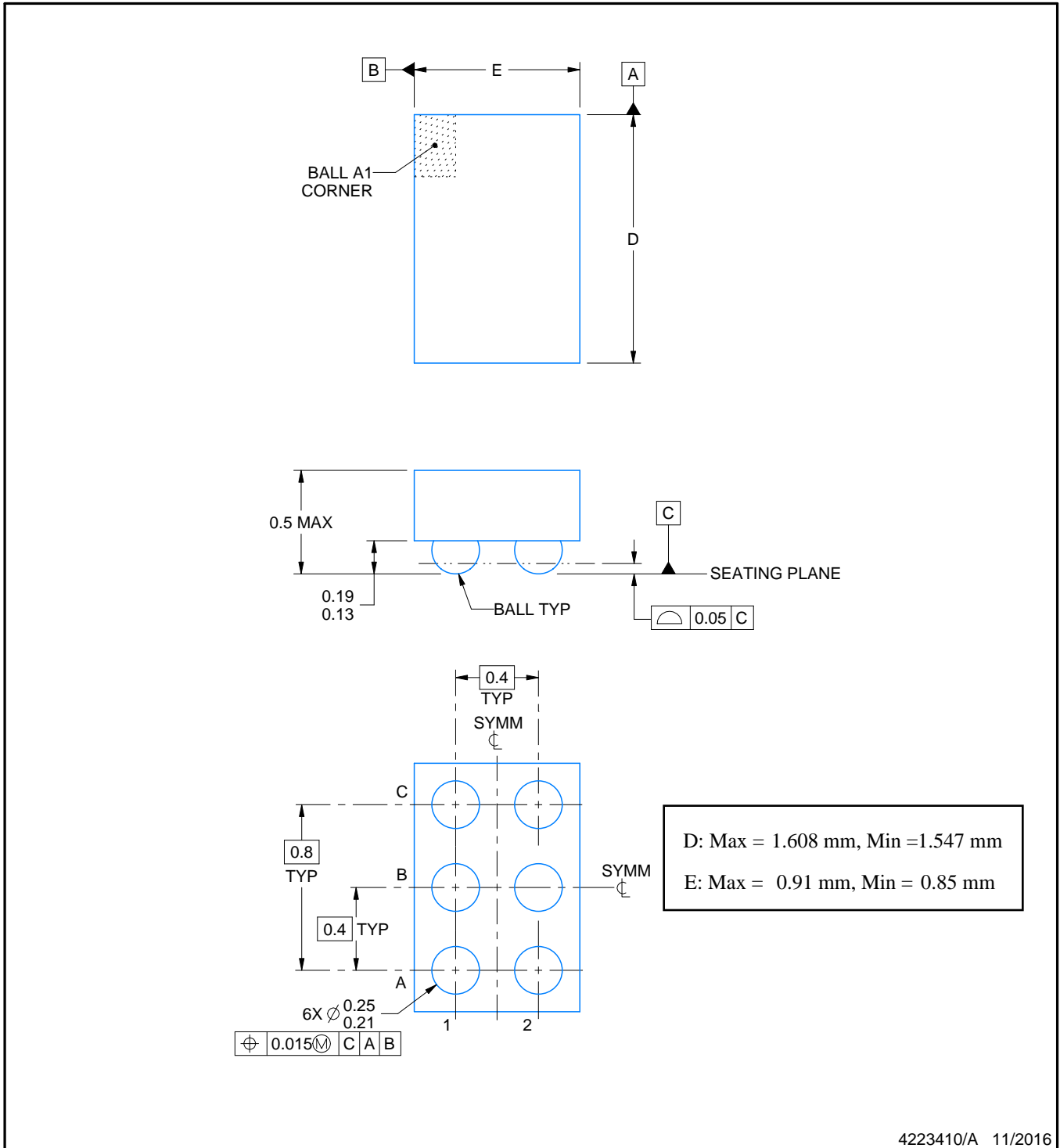

4223410/A 11/2016

NOTES:

1. All linear dimensions are in millimeters. Any dimensions in parenthesis are for reference only. Dimensioning and tolerancing per ASME Y14.5M.
2. This drawing is subject to change without notice.

EXAMPLE BOARD LAYOUT

YFP0006

DSBGA - 0.5 mm max height

DIE SIZE BALL GRID ARRAY

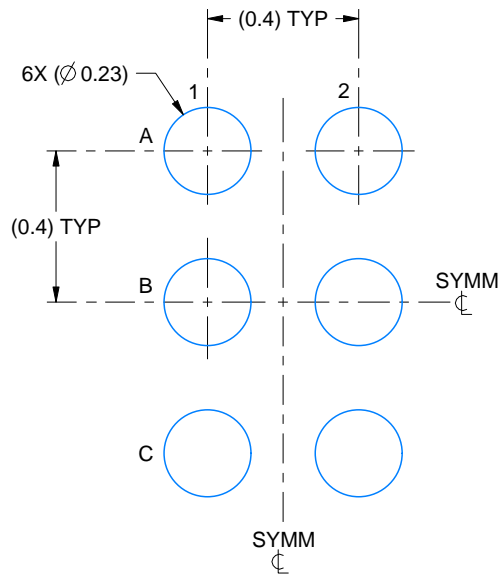

LAND PATTERN EXAMPLE
SCALE:50X

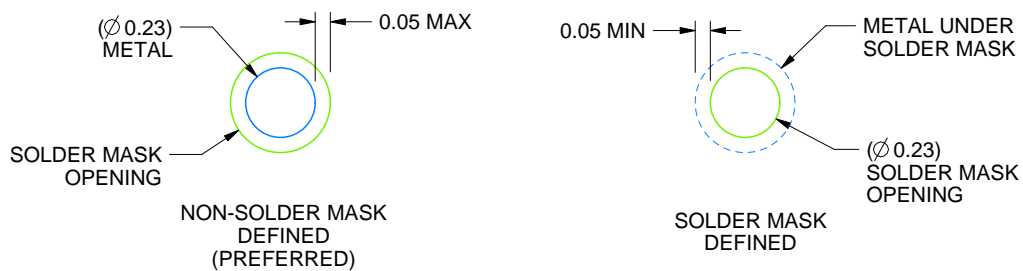

SOLDER MASK DETAILS
NOT TO SCALE

4223410/A 11/2016

NOTES: (continued)

- Final dimensions may vary due to manufacturing tolerance considerations and also routing constraints. For more information, see Texas Instruments literature number SNVA009 (www.ti.com/lit/snva009).

EXAMPLE STENCIL DESIGN

YFP0006

DSBGA - 0.5 mm max height

DIE SIZE BALL GRID ARRAY

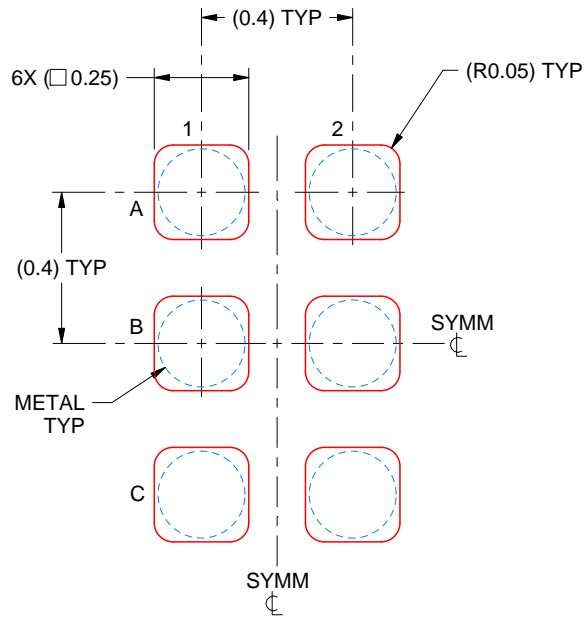

SOLDER PASTE EXAMPLE
BASED ON 0.1 mm THICK STENCIL
SCALE:50X

4223410/A 11/2016

NOTES: (continued)

4. Laser cutting apertures with trapezoidal walls and rounded corners may offer better paste release.

重要声明和免责声明

TI 均以“原样”提供技术性及其可靠性数据（包括数据表）、设计资源（包括参考设计）、应用或其他设计建议、网络工具、安全信息和其他资源，不保证其中不含任何瑕疵，且不做任何明示或暗示的担保，包括但不限于对适销性、适合某特定用途或不侵犯任何第三方知识产权的暗示担保。

所述资源可供专业开发人员应用TI 产品进行设计使用。您将对以下行为独自承担全部责任：(1) 针对您的应用选择合适的TI 产品；(2) 设计、验证并测试您的应用；(3) 确保您的应用满足相应标准以及任何其他安全、安保或其他要求。所述资源如有变更，恕不另行通知。TI 对您使用所述资源的授权仅限于开发资源所涉及TI 产品的相关应用。除此之外不得复制或展示所述资源，也不提供其它TI 或任何第三方的知识产权授权许可。如因使用所述资源而产生任何索赔、赔偿、成本、损失及债务等，TI 对此概不负责，并且您须赔偿由此对TI 及其代表造成的损害。

TI 所提供产品均受TI 的销售条款 (<http://www.ti.com.cn/zh-cn/legal/termsofsale.html>) 以及ti.com.cn上或随附TI产品提供的其他可适用条款的约束。TI提供所述资源并不扩展或以其他方式更改TI 针对TI 产品所发布的可适用的担保范围或担保免责声明。

邮寄地址：上海市浦东新区世纪大道 1568 号中建大厦 32 楼，邮政编码：200122

Copyright © 2020 德州仪器半导体技术（上海）有限公司