

LMx85-2.5、LM385B-2.5 低功耗电压基准

1 特性

- 工作电流范围 20 μ A 至 20mA
- 1.5% 和 3% 初始电压容差
- 基准阻抗
 - LM385 在 25°C 时最大值为 1 Ω
 - 所有器件在整个温度范围内的最大值均为 1.5 Ω
- 极低功耗

2 应用

- 便携式仪表基准
- 便携式测试仪表
- 电池供电型系统
- 电流环路仪表
- 面板仪表

3 说明

LMx85-2.5 和 LM385B 是微功率、双端子、带隙电压基准器件，工作电流范围为 20 μ A 至 20mA，具有极低的动态阻抗和良好的温度稳定性。片上微调可提供范围更小的电压容差。这些器件的带隙基准具有噪声低和长期稳定的特点。

该设计使得这些器件极不容易受容性负载影响，因此在大多数基准中更易于使用。应用中，低功耗是一个关键问题。宽动态工作温度范围可适应各种电流供应需求，并具有出色的稳压功能。

该系列的超低耗用功率使这些器件对低功耗电路非常有用。这些电压基准可用于设计便携式仪表、稳压器或通用模拟电路，电池寿命接近保质期。这些电压基准的宽工作电流范围使其能够用容差范围更小的器件替换旧的基准。

器件信息⁽¹⁾

器件型号	封装	封装尺寸 (标称值)
LMx85D-2-5、 LM385BD-2-5	SOIC (8)	4.90mm x 3.90mm
LMx85LP-2-5、 LM385BLP-2-5	TO-92 (3)	4.30mm x 4.30mm
LM385PW-2-5、 LM385BPW-2-5	TSSOP (8)	3.00mm x 4.40mm

(1) 如需了解所有可用封装，请参阅数据表末尾的可订购产品附录。

简化原理图



目录

1	特性	1	8	Application and Implementation	9
2	应用	1	8.1	Application Information.....	9
3	说明	1	8.2	Typical Application	9
4	修订历史记录	2	8.3	System Examples	10
5	Pin Configuration and Functions	3	9	Power Supply Recommendations	11
6	Specifications	4	10	Layout	11
6.1	Absolute Maximum Ratings	4	10.1	Layout Guidelines	11
6.2	ESD Ratings.....	4	10.2	Layout Example	11
6.3	Recommended Operating Conditions.....	4	11	器件和文档支持	12
6.4	Thermal Information	4	11.1	相关链接.....	12
6.5	Electrical Characteristics.....	5	11.2	接收文档更新通知	12
6.6	Typical Characteristics	6	11.3	社区资源.....	12
7	Detailed Description	8	11.4	商标.....	12
7.1	Overview	8	11.5	静电放电警告.....	12
7.2	Functional Block Diagram	8	11.6	Glossary	12
7.3	Feature Description.....	8	12	机械、封装和可订购信息	12
7.4	Device Functional Modes.....	8			

4 修订历史记录

Changes from Revision K (March 2016) to Revision L Page

- Changed ANODE pin description from: Shunt Current/Voltage input to: Common pin, normally connected to ground..... **3**
- Changed CATHODE pin description from: Common pin, normally connected to ground to: Shunt Current/Voltage input ... **3**

Changes from Revision J (March 2005) to Revision K Page

- 已添加 特性 部分、器件信息表、目录、修订历史记录 部分、引脚配置和功能 部分、规格 部分、绝对最大额定值表、ESD 额定值表、热性能信息表、详细 说明 部分、应用和实施 部分、电源相关建议 部分、布局 部分、器件和文档支持 部分以及机械、封装和可订购信息 部分..... **1**

5 Pin Configuration and Functions

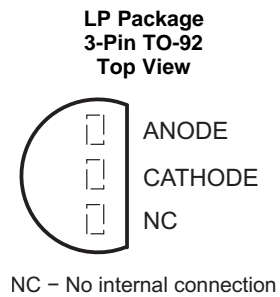
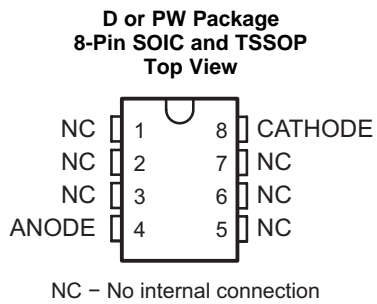

Pin Functions

NAME	PIN			TYPE	DESCRIPTION
	NO.				
	SOIC	TSSOP	TO-92		
ANODE	4			I	Common pin, typically connected to ground
CATHODE	8			O	Shunt Current/Voltage Input
NC	1, 2, 3, 5, 6, 7			—	No Internal Connection

6 Specifications

6.1 Absolute Maximum Ratings

over operating free-air temperature range (unless otherwise noted)⁽¹⁾

		MIN	MAX	UNIT
I_R	Reverse current		30	mA
I_F	Forward current		10	mA
	Lead temperature 1.6 mm (1/16 inch) from case for 10 seconds		260	°C
T_J	Junction temperature		150	°C
T_{stg}	Storage temperature	-65	150	°C

(1) Stresses beyond those listed under *Absolute Maximum Ratings* may cause permanent damage to the device. These are stress ratings only, which do not imply functional operation of the device at these or any other conditions beyond those indicated under *Recommended Operating Conditions*. Exposure to absolute-maximum-rated conditions for extended periods may affect device reliability.

6.2 ESD Ratings

			VALUE	UNIT
$V_{(ESD)}$	Electrostatic discharge	Human-body model (HBM), per ANSI/ESDA/JEDEC JS-001 ⁽¹⁾	±2000	V
		Charged-device model (CDM), per JEDEC specification JESD22-C101 ⁽²⁾	±1000	

(1) JEDEC document JEP155 states that 500-V HBM allows safe manufacturing with a standard ESD control process.

(2) JEDEC document JEP157 states that 250-V CDM allows safe manufacturing with a standard ESD control process.

6.3 Recommended Operating Conditions

over operating free-air temperature range (unless otherwise noted)

			MIN	MAX	UNIT
I_Z	Reference current		0.02	20	mA
T_A	Operating free-air temperature	LM285-2.5	-40	85	°C
		LM385-2.5, LM385B-2.5	0	70	

6.4 Thermal Information

THERMAL METRIC ⁽¹⁾	LMx85-2.5, LM385B-2.5			UNIT	
	D (SOIC)	LP (T0-92)	PW (TSSOP)		
	8 PINS	3 PINS	8 PINS		
$R_{\theta JA}$	Junction-to-ambient thermal resistance	112	157	168.3	°C/W
$R_{\theta JC(top)}$	Junction-to-case (top) thermal resistance	58.5	80.3	53.7	°C/W
$R_{\theta JB}$	Junction-to-board thermal resistance	52.1	N/A	96.4	°C/W
Ψ_{JT}	Junction-to-top characterization parameter	15.8	24.6	4.5	°C/W
Ψ_{JB}	Junction-to-board characterization parameter	51.7	136.2	94.7	°C/W

(1) For more information about traditional and new thermal metrics, see the *IC Package Thermal Metrics* (SPRA953) application report.

6.5 Electrical Characteristics

$T_A = 25^\circ\text{C}$ unless otherwise noted.

PARAMETER		TEST CONDITIONS		MIN	TYP	MAX	UNIT
LM285-2.5							
V_Z	Reference voltage	$I_Z = 20\ \mu\text{A}$ to 20 mA		2.462	2.5	2.538	V
$^{\alpha}V_Z$	Average temperature coefficient of reference voltage ⁽¹⁾	$I_Z = 20\ \mu\text{A}$ to 20 mA	Full range ⁽²⁾		± 20		ppm/ $^\circ\text{C}$
ΔV_Z	Change in reference voltage with current	$I_Z = 20\ \mu\text{A}$ to 1 mA	$T_A = 25^\circ\text{C}$			1	mV
			Full range			1.5	
		$I_Z = 1\ \text{mA}$ to 20 mA	$T_A = 25^\circ\text{C}$			10	
			Full range			30	
$\Delta V_Z/\Delta t$	Long-term change in reference voltage	$I_Z = 100\ \mu\text{A}$			± 20		ppm/khr
$I_{Z(\text{MIN})}$	Minimum reference current	Full range			8	20	μA
z_z	Reference impedance	$I_Z = 100\ \mu\text{A}$	$T_A = 25^\circ\text{C}$		0.2	0.6	Ω
			Full range			1.5	
V_n	Broadband noise voltage	$I_Z = 100\ \mu\text{A}$, $f = 10\ \text{Hz}$ to 10 kHz			120		μV
LM385-2.5							
V_Z	Reference voltage	$I_Z = 20\ \mu\text{A}$ to 20 mA		2.425	2.5	2.575	V
$^{\alpha}V_Z$	Average temperature coefficient of reference voltage ⁽¹⁾	$I_Z = 20\ \mu\text{A}$ to 20 mA	Full range ⁽²⁾		± 20		ppm/ $^\circ\text{C}$
ΔV_Z	Change in reference voltage with current	$I_Z = 20\ \mu\text{A}$ to 1 mA	$T_A = 25^\circ\text{C}$			2	mV
			Full range			2	
		$I_Z = 1\ \text{mA}$ to 20 mA	$T_A = 25^\circ\text{C}$			20	
			Full range			30	
$\Delta V_Z/\Delta t$	Long-term change in reference voltage	$I_Z = 100\ \mu\text{A}$			± 20		ppm/khr
$I_{Z(\text{MIN})}$	Minimum reference current	Full range			8	20	μA
z_z	Reference impedance	$I_Z = 100\ \mu\text{A}$	$T_A = 25^\circ\text{C}$		0.4	1	Ω
			Full range			1.5	
V_n	Broadband noise voltage	$I_Z = 100\ \mu\text{A}$, $f = 10\ \text{Hz}$ to 10 kHz			120		μV
LM385B-2.5							
V_Z	Reference voltage	$I_Z = 20\ \mu\text{A}$ to 20 mA		2.462	2.5	2.538	V
$^{\alpha}V_Z$	Average temperature coefficient of reference voltage ⁽¹⁾	$I_Z = 20\ \mu\text{A}$ to 20 mA	Full range ⁽²⁾		± 20		ppm/ $^\circ\text{C}$
ΔV_Z	Change in reference voltage with current	$I_Z = 20\ \mu\text{A}$ to 1 mA	$T_A = 25^\circ\text{C}$			2	mV
			Full range			2	
		$I_Z = 1\ \text{mA}$ to 20 mA	$T_A = 25^\circ\text{C}$			20	
			Full range			30	
$\Delta V_Z/\Delta t$	Long-term change in reference voltage	$I_Z = 100\ \mu\text{A}$			± 20		ppm/khr
$I_{Z(\text{MIN})}$	Minimum reference current	Full range			8	20	μA
z_z	Reference impedance	$I_Z = 100\ \mu\text{A}$	$T_A = 25^\circ\text{C}$		0.4	1	Ω
			Full range			1.5	
V_n	Broadband noise voltage	$I_Z = 100\ \mu\text{A}$, $f = 10\ \text{Hz}$ to 10 kHz			120		μV

(1) The average temperature coefficient of reference voltage is defined as the total change in reference voltage divided by the specified temperature range.

(2) Full range is 0°C to 70°C for the LM385-2.5 and LM385B-2.5, and -40°C to 85°C for the LM285-2.5.

6.6 Typical Characteristics

Data at high and low temperatures are applicable only within the rated operating free-air temperature ranges of the various devices. For conditions shown as MIN or MAX, use the appropriate value specified under recommended operating conditions.

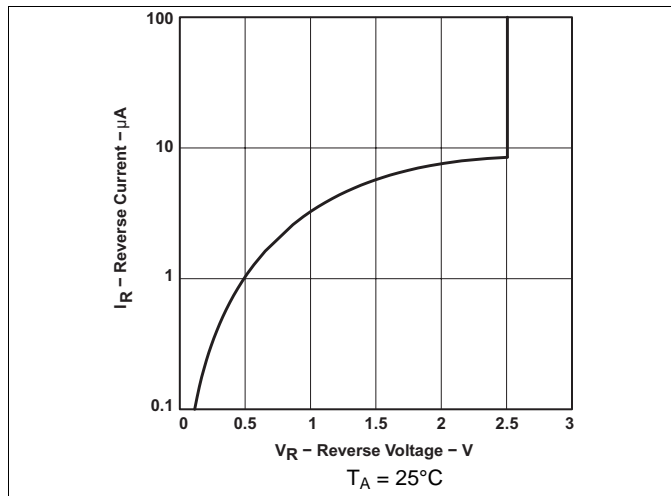

Figure 1. Reverse Current vs Reverse Voltage

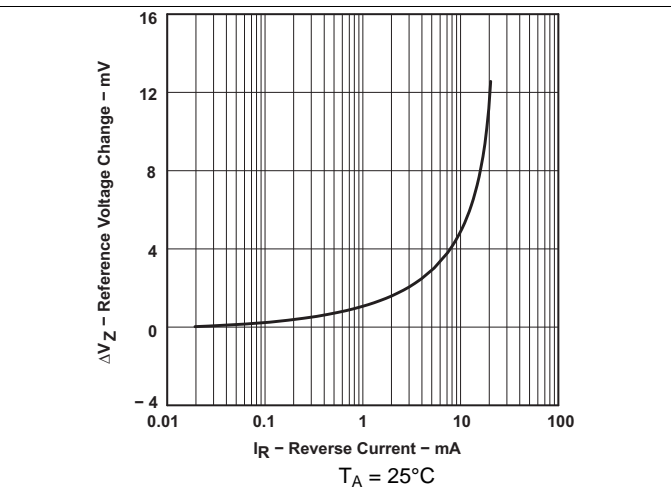

Figure 2. Reference Voltage Change vs Reverse Current

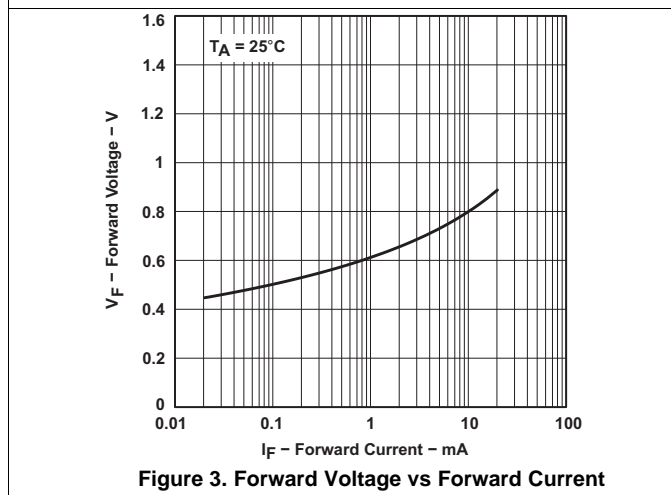

Figure 3. Forward Voltage vs Forward Current

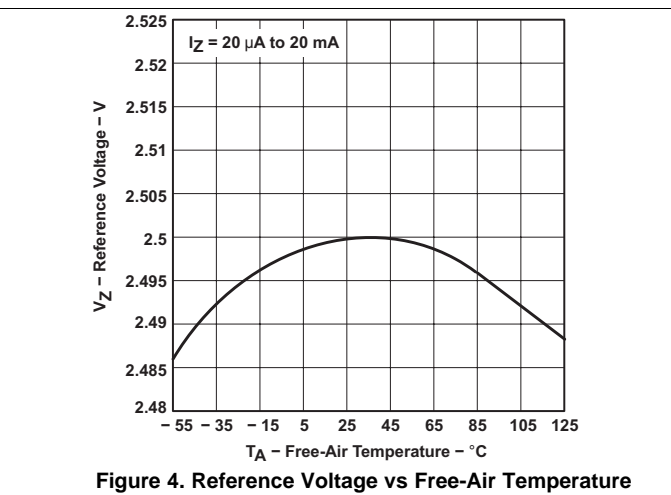

Figure 4. Reference Voltage vs Free-Air Temperature

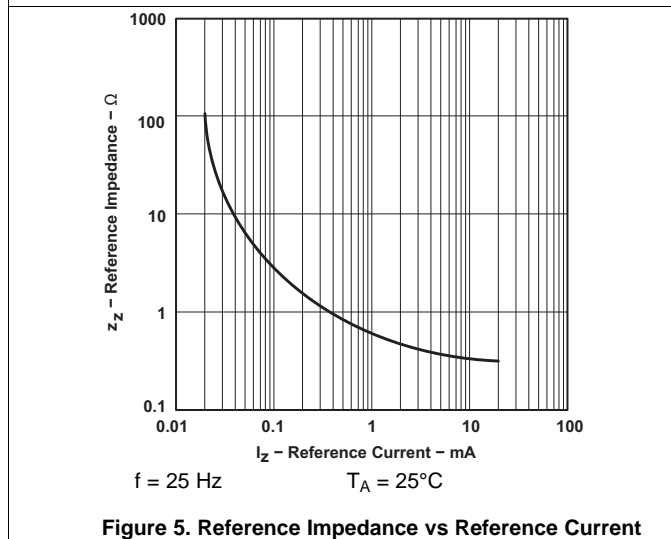

Figure 5. Reference Impedance vs Reference Current

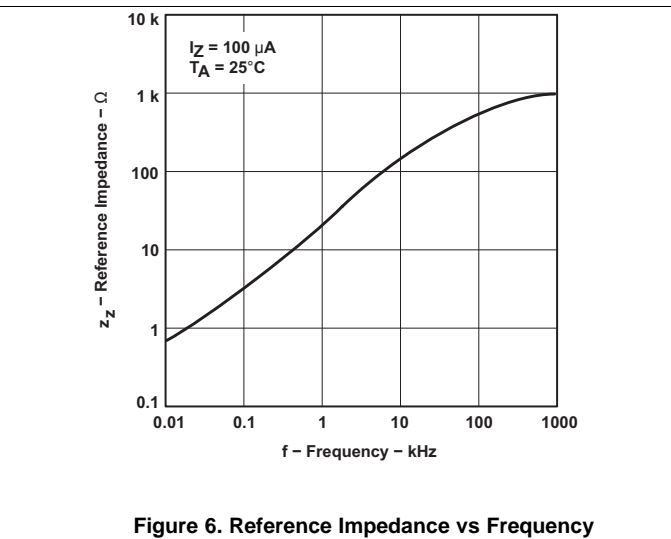

Figure 6. Reference Impedance vs Frequency

Typical Characteristics (continued)

Data at high and low temperatures are applicable only within the rated operating free-air temperature ranges of the various devices. For conditions shown as MIN or MAX, use the appropriate value specified under recommended operating conditions.

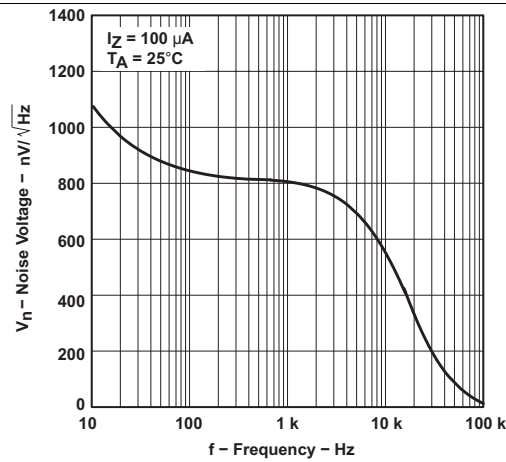

Figure 7. Noise Voltage vs Frequency

7 Detailed Description

7.1 Overview

The LMx85-2.5 and LM385B-2.5 devices maintain a nearly constant voltage between the cathode and anode of 2.5 V when the minimum cathode current up to the recommended maximum is provided. See [Recommended Operating Conditions](#) for recommended minimum cathode current.

7.2 Functional Block Diagram

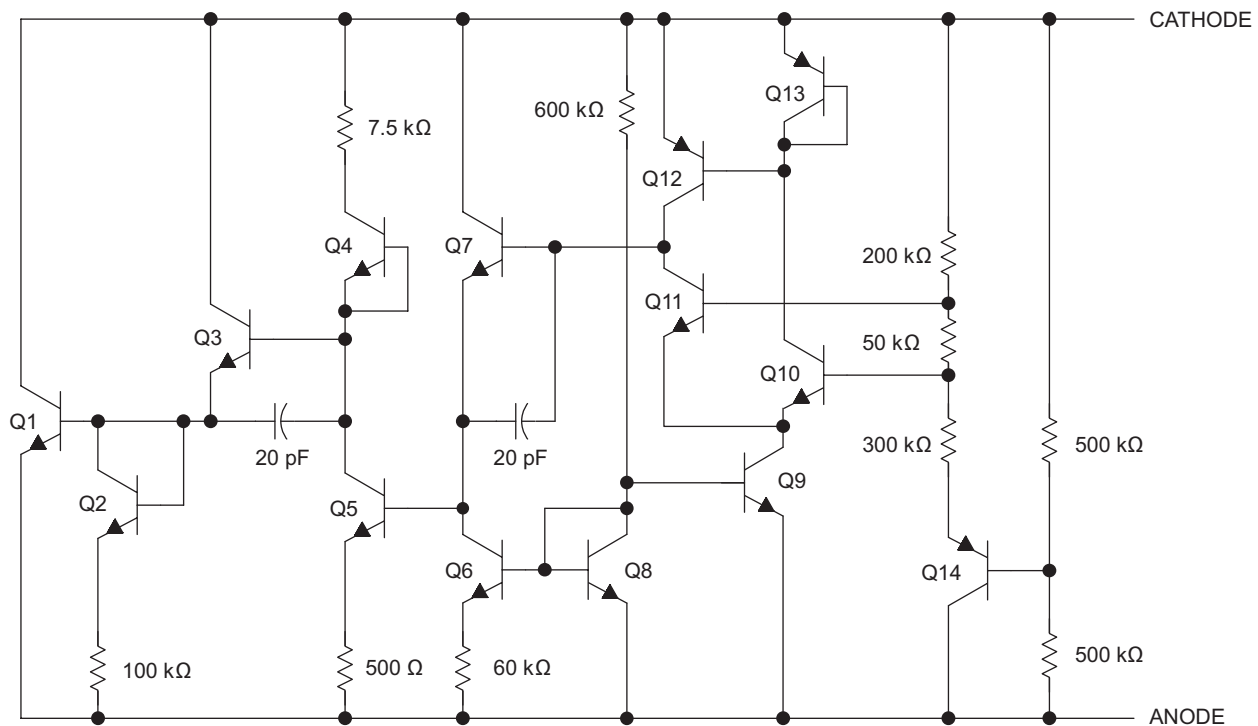

7.3 Feature Description

A band-gap voltage reference controls a high-gain amplifier and shunt pass element to maintain a nearly constant voltage between the cathode and anode of 2.5 V. Regulation occurs after a minimum current is provided to power the voltage divider and amplifier. Internal frequency compensation provides a stable loop for all capacitive loads. Floating shunt design is useful for both positive and negative regulation applications.

7.4 Device Functional Modes

The LMx85-2.5 and LM385B-2.5 devices have a single functional mode. These devices can be used as 2.5-V fixed voltage references. The reference voltage cannot be adjusted for these devices.

For a proper Reverse Voltage to be developed, current must be sourced into the cathode of LM285. The minimum current needed for proper regulation is denoted in [Electrical Characteristics](#) as $I_{Z(MIN)}$.

8 Application and Implementation

NOTE

Information in the following applications sections is not part of the TI component specification, and TI does not warrant its accuracy or completeness. TI's customers are responsible for determining suitability of components for their purposes. Customers should validate and test their design implementation to confirm system functionality.

8.1 Application Information

The LMx85-2.5 and LM385B-2.5 devices create a voltage reference for use in a variety of applications including amplifiers, power supplies, and current-sensing circuits.

8.2 Typical Application

Figure 8 shows how to use these devices to establish a 2.5-V source from a 9-V battery.

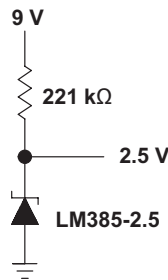

Figure 8. Reference From a 9-V Battery

8.2.1 Design Requirements

The key design requirement when using this device as a voltage reference is to supply the LM385 with a minimum Cathode Current (I_Z), as indicated in [Electrical Characteristics](#).

8.2.2 Detailed Design Procedure

To generate a constant and stable reference voltage, a current greater than $I_{Z(MIN)}$ must be sourced into the cathode of this device. This can be accomplished using a current regulating device such as LM334 or a simple resistor. For a resistor, its value should be equal to or greater than $(V_{supply} - V_{reference}) \div I_{Z(MIN)}$.

8.2.3 Application Curve

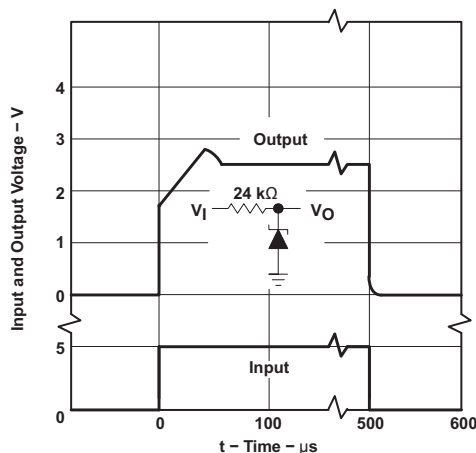
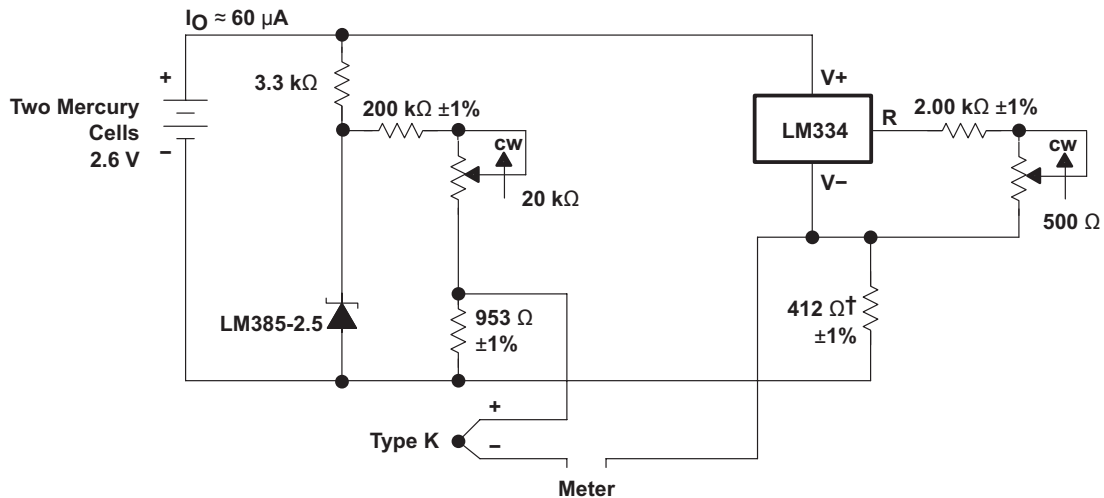

Figure 9. Device Transient Response

8.3 System Examples

8.3.1 Thermocouple Cold-Junction Compensator

Figure 10 shows how to use the LM385-2.5 in a circuit for thermocouple cold-junction compensation.



† Adjust for 12.17 mV at 25°C across 412 Ω

Figure 10. Thermocouple Cold-Junction Compensator

8.3.2 Generating Reference Voltage With a Constant Current Source

The LM334 device can be used to set the cathode current of the LM385-2.5 device over a wide range of input voltages to ensure proper voltage regulation by the LM385-2.5 device.

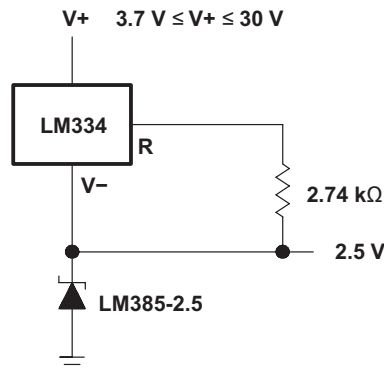

Figure 11. Generating Reference Voltage With a Constant Current Source Device

9 Power Supply Recommendations

The supply voltage should be current limited to ensure that the maximum cathode current is not exceeded.

For applications shunting high currents (30 mA maximum), pay attention to the cathode and anode trace lengths, and adjust the width of the traces to have the proper current density.

10 Layout

10.1 Layout Guidelines

Figure 12 shows an example of a PCB layout of LMx85x-2.5. Some key V_{ref} noise considerations are:

- It is optional to connect a low-ESR, 0.1- μ F (C_L) ceramic bypass capacitor on the cathode pin node.
- Decouple other active devices in the system per the device specifications.
- Using a solid ground plane helps distribute heat and reduces electromagnetic interference (EMI) noise pickup.
- Place the external components as close to the device as possible. This configuration prevents parasitic errors (such as the Seebeck effect) from occurring.
- Do not run sensitive analog traces in parallel with digital traces. Avoid crossing digital and analog traces if possible and only make perpendicular crossings when absolutely necessary.

10.2 Layout Example

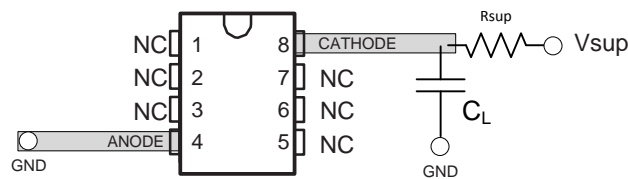

Figure 12. Layout Diagram

11 器件和文档支持

11.1 相关链接

下表列出了快速访问链接。类别包括技术文档、支持和社区资源、工具和软件以及申请样片或购买产品的快速访问链接。

表 1. 相关链接

器件	产品文件夹	样片与购买	技术文档	工具和软件	支持和社区
LM285-2.5	请单击此处	请单击此处	请单击此处	请单击此处	请单击此处
LM385-2.5	请单击此处	请单击此处	请单击此处	请单击此处	请单击此处
LM385B-2.5	请单击此处	请单击此处	请单击此处	请单击此处	请单击此处

11.2 接收文档更新通知

要接收文档更新通知，请导航至 TI.com 上的器件产品文件夹。请单击右上角的 **提醒我** 进行注册，即可每周接收产品信息更改摘要。有关更改的详细信息，请查看任何已修订文档中包含的修订历史记录。

11.3 社区资源

下列链接提供到 TI 社区资源的连接。链接的内容由各个分销商“按照原样”提供。这些内容并不构成 TI 技术规范，并且不一定反映 TI 的观点；请参阅 TI 的 [《使用条款》](#)。

TI E2E™ 在线社区 *TI 的工程师对工程师 (E2E) 社区*。此社区的创建目的在于促进工程师之间的协作。在 e2e.ti.com 中，您可以咨询问题、分享知识、拓展思路并与同行工程师一道帮助解决问题。

设计支持 *TI 参考设计支持* 可帮助您快速查找有帮助的 E2E 论坛、设计支持工具以及技术支持的联系信息。

11.4 商标

E2E is a trademark of Texas Instruments.
All other trademarks are the property of their respective owners.

11.5 静电放电警告



这些装置包含有限的内置 ESD 保护。存储或装卸时，应将导线一起截短或将装置放置于导电泡棉中，以防止 MOS 门极遭受静电损伤。

11.6 Glossary

[SLYZ022](#) — *TI Glossary*.

This glossary lists and explains terms, acronyms, and definitions.

12 机械、封装和可订购信息

以下页面包含机械、封装和可订购信息。这些信息是指定器件的最新可用数据。数据如有变更，恕不另行通知和修订此文档。如欲获取此数据表的浏览器版本，请参阅左侧的导航。

PACKAGING INFORMATION

Orderable Device	Status (1)	Package Type	Package Drawing	Pins	Package Qty	Eco Plan (2)	Lead finish/ Ball material (6)	MSL Peak Temp (3)	Op Temp (°C)	Device Marking (4/5)	Samples
LM285D-2-5	ACTIVE	SOIC	D	8	75	RoHS & Green	NIPDAU	Level-1-260C-UNLIM	-40 to 85	285-25	Samples
LM285DG4-2-5	ACTIVE	SOIC	D	8	75	RoHS & Green	NIPDAU	Level-1-260C-UNLIM	-40 to 85	285-25	Samples
LM285DR-2-5	ACTIVE	SOIC	D	8	2500	RoHS & Green	NIPDAU	Level-1-260C-UNLIM	-40 to 85	285-25	Samples
LM285DRG4-2-5	ACTIVE	SOIC	D	8	2500	RoHS & Green	NIPDAU	Level-1-260C-UNLIM	-40 to 85	285-25	Samples
LM285LP-2-5	ACTIVE	TO-92	LP	3	1000	RoHS & Green	SN	N / A for Pkg Type	-40 to 85	285-25	Samples
LM285LPE3-2-5	ACTIVE	TO-92	LP	3	1000	RoHS & Green	SN	N / A for Pkg Type	-40 to 85	285-25	Samples
LM285LPR-2-5	ACTIVE	TO-92	LP	3	2000	RoHS & Green	SN	N / A for Pkg Type	-40 to 85	285-25	Samples
LM285LPRE3-2-5	ACTIVE	TO-92	LP	3	2000	RoHS & Green	SN	N / A for Pkg Type	-40 to 85	285-25	Samples
LM385BD-2-5	ACTIVE	SOIC	D	8	75	RoHS & Green	NIPDAU	Level-1-260C-UNLIM	0 to 70	385B25	Samples
LM385BDE4-2-5	ACTIVE	SOIC	D	8	75	RoHS & Green	NIPDAU	Level-1-260C-UNLIM	0 to 70	385B25	Samples
LM385BDR-2-5	ACTIVE	SOIC	D	8	2500	RoHS & Green	NIPDAU	Level-1-260C-UNLIM	0 to 70	385B25	Samples
LM385BLP-2-5	ACTIVE	TO-92	LP	3	1000	RoHS & Green	SN	N / A for Pkg Type	0 to 70	385B25	Samples
LM385BLPE3-2-5	ACTIVE	TO-92	LP	3	1000	RoHS & Green	SN	N / A for Pkg Type	0 to 70	385B25	Samples
LM385BLPR-2-5	ACTIVE	TO-92	LP	3	2000	RoHS & Green	SN	N / A for Pkg Type	0 to 70	385B25	Samples
LM385BPWR-2-5	ACTIVE	TSSOP	PW	8	2000	RoHS & Green	NIPDAU	Level-1-260C-UNLIM	0 to 70	385B25	Samples
LM385D-2-5	ACTIVE	SOIC	D	8	75	RoHS & Green	NIPDAU	Level-1-260C-UNLIM	0 to 70	385-25	Samples
LM385DR-2-5	ACTIVE	SOIC	D	8	2500	RoHS & Green	NIPDAU	Level-1-260C-UNLIM	0 to 70	385-25	Samples
LM385DRG4-2-5	ACTIVE	SOIC	D	8	2500	RoHS & Green	NIPDAU	Level-1-260C-UNLIM	0 to 70	385-25	Samples
LM385LP-2-5	ACTIVE	TO-92	LP	3	1000	RoHS & Green	SN	N / A for Pkg Type	0 to 70	385-25	Samples
LM385LPE3-2-5	ACTIVE	TO-92	LP	3	1000	RoHS & Green	SN	N / A for Pkg Type	0 to 70	385-25	Samples

Orderable Device	Status (1)	Package Type	Package Drawing	Pins	Package Qty	Eco Plan (2)	Lead finish/ Ball material (6)	MSL Peak Temp (3)	Op Temp (°C)	Device Marking (4/5)	Samples
LM385LPR-2-5	ACTIVE	TO-92	LP	3	2000	RoHS & Green	SN	N / A for Pkg Type	0 to 70	385-25	Samples
LM385PWR-2-5	ACTIVE	TSSOP	PW	8	2000	RoHS & Green	NIPDAU	Level-1-260C-UNLIM	0 to 70	385-25	Samples

(1) The marketing status values are defined as follows:

ACTIVE: Product device recommended for new designs.

LIFEBUY: TI has announced that the device will be discontinued, and a lifetime-buy period is in effect.

NRND: Not recommended for new designs. Device is in production to support existing customers, but TI does not recommend using this part in a new design.

PREVIEW: Device has been announced but is not in production. Samples may or may not be available.

OBSOLETE: TI has discontinued the production of the device.

(2) **RoHS:** TI defines "RoHS" to mean semiconductor products that are compliant with the current EU RoHS requirements for all 10 RoHS substances, including the requirement that RoHS substance do not exceed 0.1% by weight in homogeneous materials. Where designed to be soldered at high temperatures, "RoHS" products are suitable for use in specified lead-free processes. TI may reference these types of products as "Pb-Free".

RoHS Exempt: TI defines "RoHS Exempt" to mean products that contain lead but are compliant with EU RoHS pursuant to a specific EU RoHS exemption.

Green: TI defines "Green" to mean the content of Chlorine (Cl) and Bromine (Br) based flame retardants meet JS709B low halogen requirements of <=1000ppm threshold. Antimony trioxide based flame retardants must also meet the <=1000ppm threshold requirement.

(3) **MSL, Peak Temp.** - The Moisture Sensitivity Level rating according to the JEDEC industry standard classifications, and peak solder temperature.

(4) There may be additional marking, which relates to the logo, the lot trace code information, or the environmental category on the device.

(5) Multiple Device Markings will be inside parentheses. Only one Device Marking contained in parentheses and separated by a "~" will appear on a device. If a line is indented then it is a continuation of the previous line and the two combined represent the entire Device Marking for that device.

(6) **Lead finish/Ball material** - Orderable Devices may have multiple material finish options. Finish options are separated by a vertical ruled line. Lead finish/Ball material values may wrap to two lines if the finish value exceeds the maximum column width.

Important Information and Disclaimer: The information provided on this page represents TI's knowledge and belief as of the date that it is provided. TI bases its knowledge and belief on information provided by third parties, and makes no representation or warranty as to the accuracy of such information. Efforts are underway to better integrate information from third parties. TI has taken and continues to take reasonable steps to provide representative and accurate information but may not have conducted destructive testing or chemical analysis on incoming materials and chemicals. TI and TI suppliers consider certain information to be proprietary, and thus CAS numbers and other limited information may not be available for release.

In no event shall TI's liability arising out of such information exceed the total purchase price of the TI part(s) at issue in this document sold by TI to Customer on an annual basis.

TAPE AND REEL INFORMATION

QUADRANT ASSIGNMENTS FOR PIN 1 ORIENTATION IN TAPE

*All dimensions are nominal

Device	Package Type	Package Drawing	Pins	SPQ	Reel Diameter (mm)	Reel Width W1 (mm)	A0 (mm)	B0 (mm)	K0 (mm)	P1 (mm)	W (mm)	Pin1 Quadrant
LM285DR-2-5	SOIC	D	8	2500	330.0	12.4	6.4	5.2	2.1	8.0	12.0	Q1
LM385BDR-2-5	SOIC	D	8	2500	330.0	12.4	6.4	5.2	2.1	8.0	12.0	Q1
LM385BPWR-2-5	TSSOP	PW	8	2000	330.0	12.4	7.0	3.6	1.6	8.0	12.0	Q1
LM385DR-2-5	SOIC	D	8	2500	330.0	12.4	6.4	5.2	2.1	8.0	12.0	Q1
LM385PWR-2-5	TSSOP	PW	8	2000	330.0	12.4	7.0	3.6	1.6	8.0	12.0	Q1

TAPE AND REEL BOX DIMENSIONS

*All dimensions are nominal

Device	Package Type	Package Drawing	Pins	SPQ	Length (mm)	Width (mm)	Height (mm)
LM285DR-2-5	SOIC	D	8	2500	340.5	336.1	25.0
LM385BDR-2-5	SOIC	D	8	2500	340.5	336.1	25.0
LM385BPWR-2-5	TSSOP	PW	8	2000	367.0	367.0	35.0
LM385DR-2-5	SOIC	D	8	2500	340.5	336.1	25.0
LM385PWR-2-5	TSSOP	PW	8	2000	367.0	367.0	35.0

TUBE

*All dimensions are nominal

Device	Package Name	Package Type	Pins	SPQ	L (mm)	W (mm)	T (μm)	B (mm)
LM285D-2-5	D	SOIC	8	75	507	8	3940	4.32
LM285DG4-2-5	D	SOIC	8	75	507	8	3940	4.32
LM385BD-2-5	D	SOIC	8	75	507	8	3940	4.32
LM385BDE4-2-5	D	SOIC	8	75	507	8	3940	4.32
LM385D-2-5	D	SOIC	8	75	507	8	3940	4.32

EXAMPLE BOARD LAYOUT

D0008A

SOIC - 1.75 mm max height

SMALL OUTLINE INTEGRATED CIRCUIT



LAND PATTERN EXAMPLE
EXPOSED METAL SHOWN
SCALE:8X



SOLDER MASK DETAILS

4214825/C 02/2019

NOTES: (continued)

6. Publication IPC-7351 may have alternate designs.

7. Solder mask tolerances between and around signal pads can vary based on board fabrication site.

EXAMPLE STENCIL DESIGN

D0008A

SOIC - 1.75 mm max height

SMALL OUTLINE INTEGRATED CIRCUIT



SOLDER PASTE EXAMPLE
BASED ON .005 INCH [0.125 MM] THICK STENCIL
SCALE:8X

4214825/C 02/2019

NOTES: (continued)

8. Laser cutting apertures with trapezoidal walls and rounded corners may offer better paste release. IPC-7525 may have alternate design recommendations.
9. Board assembly site may have different recommendations for stencil design.

PW0008A



PACKAGE OUTLINE
TSSOP - 1.2 mm max height

SMALL OUTLINE PACKAGE



4221848/A 02/2015

NOTES:

1. All linear dimensions are in millimeters. Any dimensions in parenthesis are for reference only. Dimensioning and tolerancing per ASME Y14.5M.
2. This drawing is subject to change without notice.
3. This dimension does not include mold flash, protrusions, or gate burrs. Mold flash, protrusions, or gate burrs shall not exceed 0.15 mm per side.
4. This dimension does not include interlead flash. Interlead flash shall not exceed 0.25 mm per side.
5. Reference JEDEC registration MO-153, variation AA.

EXAMPLE BOARD LAYOUT

PW0008A

TSSOP - 1.2 mm max height

SMALL OUTLINE PACKAGE



LAND PATTERN EXAMPLE
SCALE:10X



SOLDER MASK DETAILS
NOT TO SCALE

4221848/A 02/2015

NOTES: (continued)

- 6. Publication IPC-7351 may have alternate designs.
- 7. Solder mask tolerances between and around signal pads can vary based on board fabrication site.

EXAMPLE STENCIL DESIGN

PW0008A

TSSOP - 1.2 mm max height

SMALL OUTLINE PACKAGE



SOLDER PASTE EXAMPLE
BASED ON 0.125 mm THICK STENCIL
SCALE:10X

4221848/A 02/2015

NOTES: (continued)

8. Laser cutting apertures with trapezoidal walls and rounded corners may offer better paste release. IPC-7525 may have alternate design recommendations.
9. Board assembly site may have different recommendations for stencil design.

GENERIC PACKAGE VIEW

LP 3

TO-92 - 5.34 mm max height

TRANSISTOR OUTLINE



Images above are just a representation of the package family, actual package may vary.
Refer to the product data sheet for package details.

4040001-2/F

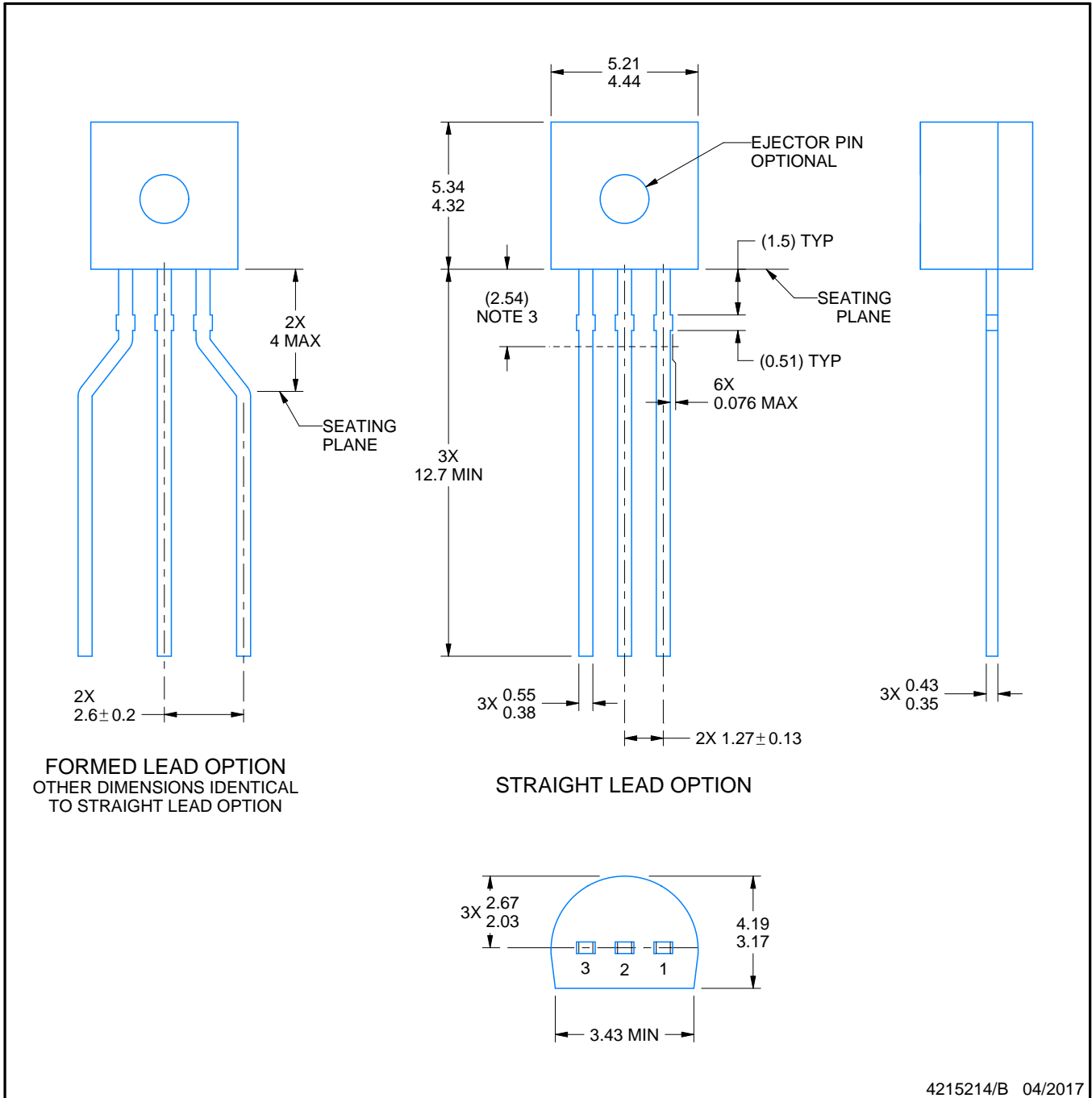

4215214/B 04/2017

NOTES:

1. All linear dimensions are in millimeters. Any dimensions in parenthesis are for reference only. Dimensioning and tolerancing per ASME Y14.5M.
2. This drawing is subject to change without notice.
3. Lead dimensions are not controlled within this area.
4. Reference JEDEC TO-226, variation AA.
5. Shipping method:
 - a. Straight lead option available in bulk pack only.
 - b. Formed lead option available in tape and reel or ammo pack.
 - c. Specific products can be offered in limited combinations of shipping medium and lead options.
 - d. Consult product folder for more information on available options.

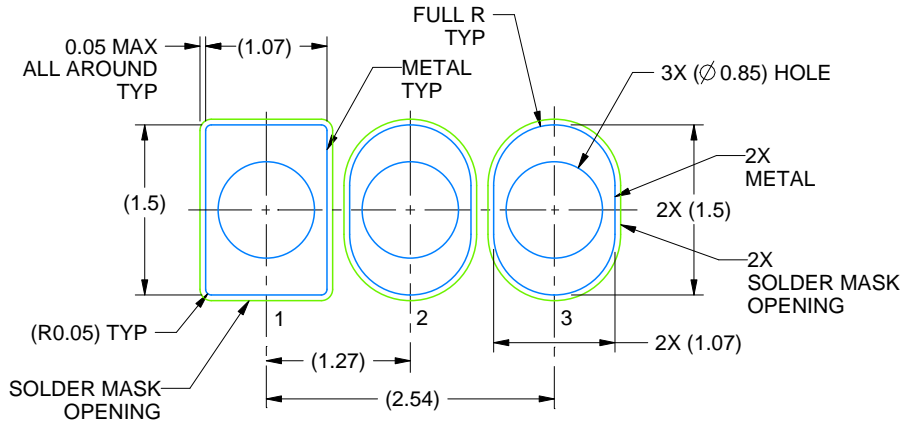

LAND PATTERN EXAMPLE
STRAIGHT LEAD OPTION
NON-SOLDER MASK DEFINED
SCALE:15X



LAND PATTERN EXAMPLE
FORMED LEAD OPTION
NON-SOLDER MASK DEFINED
SCALE:15X

TAPE SPECIFICATIONS

LP0003A

TO-92 - 5.34 mm max height

TO-92

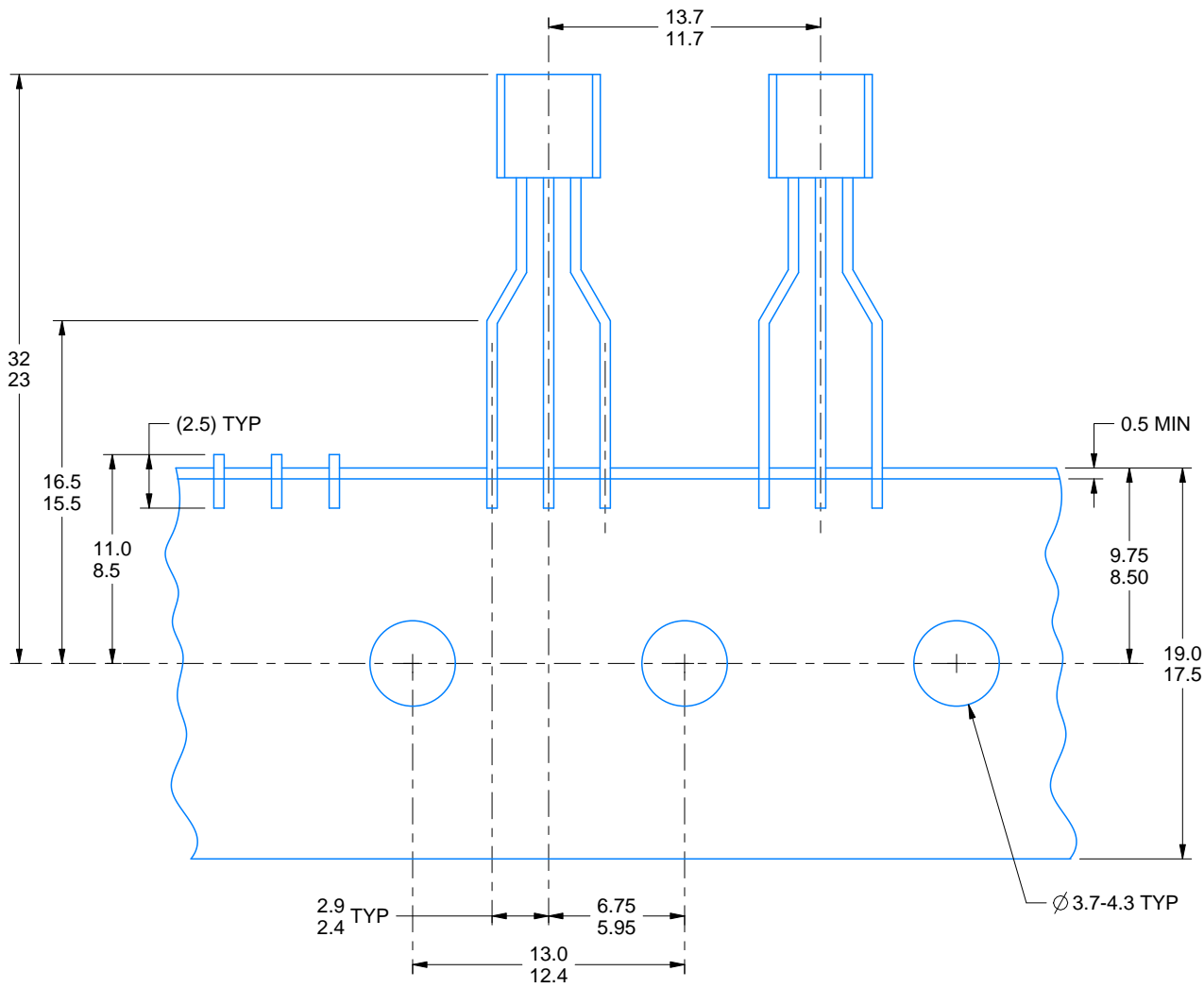

FOR FORMED LEAD OPTION PACKAGE

4215214/B 04/2017

重要声明和免责声明

TI“按原样”提供技术和可靠性数据（包括数据表）、设计资源（包括参考设计）、应用或其他设计建议、网络工具、安全信息和其他资源，不保证没有瑕疵且不做任何明示或暗示的担保，包括但不限于对适销性、某特定用途方面的适用性或不侵犯任何第三方知识产权的暗示担保。

这些资源可供使用 TI 产品进行设计的熟练开发人员使用。您将自行承担以下全部责任：(1) 针对您的应用选择合适的 TI 产品，(2) 设计、验证并测试您的应用，(3) 确保您的应用满足相应标准以及任何其他功能安全、信息安全、监管或其他要求。

这些资源如有变更，恕不另行通知。TI 授权您仅可将这些资源用于研发本资源所述的 TI 产品的应用。严禁对这些资源进行其他复制或展示。您无权使用任何其他 TI 知识产权或任何第三方知识产权。您应全额赔偿因在这些资源的使用中对 TI 及其代表造成的任何索赔、损害、成本、损失和债务，TI 对此概不负责。

TI 提供的产品受 [TI 的销售条款](#) 或 [ti.com](#) 上其他适用条款/TI 产品随附的其他适用条款的约束。TI 提供这些资源并不会扩展或以其他方式更改 TI 针对 TI 产品发布的适用的担保或担保免责声明。

TI 反对并拒绝您可能提出的任何其他或不同的条款。

邮寄地址：Texas Instruments, Post Office Box 655303, Dallas, Texas 75265

Copyright © 2022，德州仪器 (TI) 公司