

TLC7628C DUAL 8-BIT MULTIPLYING DIGITAL-TO-ANALOG CONVERTER

SLAS063B – APRIL 1989 – REVISED MARCH 2007

- Easy Microprocessor Interface
- On-Chip Data Latches
- Digital Inputs Are TTL-Compatible With 10.8-V to 15.75-V Power Supply
- Monotonic Over the Entire A/D Conversion Range
- Fast Control Signaling for Digital Signal Processor (DSP) Applications Including Interface With TMS320
- CMOS Technology

KEY PERFORMANCE SPECIFICATIONS	
Resolution	8 bits
Linearity Error	1/2 LSB
Power Dissipation	20 mW
Settling Time	100 ns
Propagation Delay Time	80 ns

DW OR N PACKAGE
(TOP VIEW)

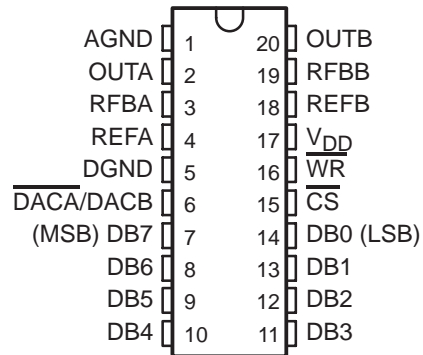

description

The TLC7628C is a dual, 8-bit, digital-to-analog converter (DAC) designed with separate on-chip data latches and featuring exceptionally close DAC-to-DAC matching. Data are transferred to either of the two DAC data latches through a common, 8-bit input port. Control input $\overline{DACA}/\overline{DACB}$ determines which DAC is loaded. The load cycle of this device is similar to the write cycle of a random-access memory, allowing easy interface to most popular microprocessor buses and output ports. Segmenting the high-order bits minimizes glitches during changes in the most significant bits, where glitch impulse is typically the strongest.

The TLC7628C operates from a 10.8-V to 15.75-V power supply and is TTL-compatible over this range. 2- or 4-quadrant multiplying makes this device a sound choice for many microprocessor-controlled gain-setting and signal-control applications.

The TLC7628C is characterized for operation from 0°C to +70°C.



Please be aware that an important notice concerning availability, standard warranty, and use in critical applications of Texas Instruments semiconductor products and disclaimers thereto appears at the end of this data sheet.

All trademarks are the property of their respective owners.

PRODUCTION DATA information is current as of publication date. Products conform to specifications per the terms of Texas Instruments standard warranty. Production processing does not necessarily include testing of all parameters.



POST OFFICE BOX 655303 • DALLAS, TEXAS 75265

Copyright © 1995 – 2007, Texas Instruments Incorporated

TLC7628C

DUAL 8-BIT MULTIPLYING

SLAS063B – APRIL 1989 – REVISED MARCH 2007

functional block diagram

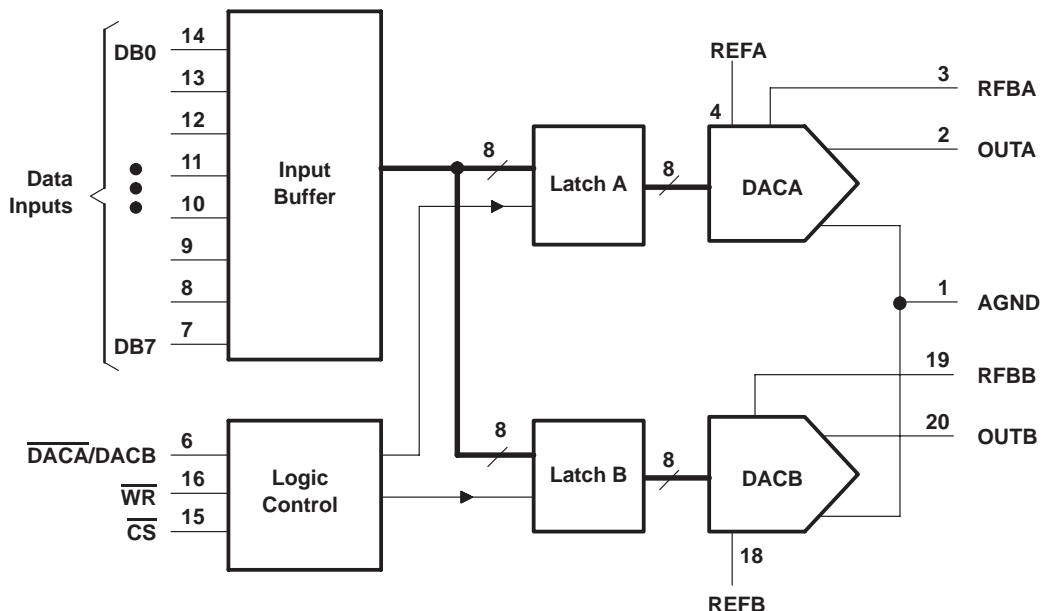

absolute maximum ratings over operating free-air temperature range (unless otherwise noted)†

Supply voltage range, V_{DD} (to AGND or DGND)	-0.3 V to 17 V
Voltage between AGND and DGND	V_{DD}
Input voltage range, V_I (to DGND)	-0.3 V to $V_{DD} + 0.3$ V
Reference voltage range, V_{refA} or V_{refB} (to AGND)	± 25 V
Feedback voltage range, V_{RFBA} or V_{RFBB} (to AGND)	± 25 V
Output voltage range, V_{OA} or V_{OB} (to AGND)	± 25 V
Peak input current	10 μ A
Operating free-air temperature range, T_A : TLC7628C	0°C to +70°C
Storage temperature range, T_{stg}	-65°C to +150°C
Case temperature for 10 seconds, T_C : FN package	+260°C
Lead temperature 1,6 mm (1/16 inch) from case for 10 seconds: DW or N package	+260°C

† Stresses beyond those listed under “absolute maximum ratings” may cause permanent damage to the device. These are stress ratings only, and functional operation of the device at these or any other conditions beyond those indicated under “recommended operating conditions” is not implied. Exposure to absolute-maximum-rated conditions for extended periods may affect device reliability.

recommended operating conditions

	MIN	NOM	MAX	UNIT
Supply voltage, V_{DD}	10.8		15.75	V
Reference voltage, V_{refA} or V_{refB}		± 10		V
High-level input voltage, V_{IH}	2.4			V
Low-level input voltage, V_{IL}			0.8	V
\overline{CS} setup time, $t_{su}(CS)$	50			ns
\overline{CS} hold time, $t_h(CS)$ (see Figure 1)	0			ns
DAC select setup time, $t_{su}(DAC)$ (see Figure 1)	60			ns
DAC select hold time, $t_h(DAC)$ (see Figure 1)	10			ns
Data bus input setup time $t_{su}(D)$ (see Figure 1)	25			ns
Data bus input hold time $t_h(D)$ (see Figure 1)	10			ns
Pulse duration, \overline{WR} low, $t_w(WR)$ (see Figure 1)	50			ns
Operating free-air temperature, T_A	TLC7628C		0	+70 °C

electrical characteristics over recommended ranges of operating free-air temperature and V_{DD} , $V_{refA} = V_{refB} = 10$ V, V_{OA} and V_{OB} at 0 V (unless otherwise noted)

PARAMETER		TEST CONDITIONS	MIN	MAX	UNIT		
I_{IH}	High-level input current	$V_I = V_{DD}$	Full range	10	μA		
			25°C	1			
I_{IL}	Low-level input current	$V_I = 0$	Full range	-10	μA		
			25°C	-1			
Reference input impedance REFA or REFB to AGND			5	20	k Ω		
I_{kg}	Output leakage current	OUTA	DAC data latch loaded with 00000000, $V_{refA} = \pm 10$ V	Full range	± 200	nA	
			25°C	± 50			
		OUTB	DAC data latch loaded with 00000000, $V_{refB} = \pm 10$ V	Full range	± 200		
			25°C	± 50			
Input resistance match (REFA to REFB)				$\pm 1\%$			
DC supply sensitivity $\Delta gain/\Delta V_{DD}$		$\Delta V_{DD} = \pm 5\%$	Full range	0.02	%/%		
			25°C	0.01			
I_{DD}	Supply current	Quiescent	All digital inputs at V_{IHmin} or V_{ILmax}		2	mA	
		Standby	All digital inputs at 0 V or V_{DD}		Full range		0.5
					25°C		0.1
C_i	Input capacitance	DB0-DB7			10	pF	
		\overline{WR} , \overline{CS} , DACA/DACB			15		
C_o	Output capacitance (OUTA, OUTB)	DAC data latches loaded with 00000000		25	pF		
		DAC data latches loaded with 11111111		60			

TLC7628C DUAL 8-BIT MULTIPLYING

SLAS063B – APRIL 1989 – REVISED MARCH 2007

operating characteristics over recommended ranges of operating free-air temperature and V_{DD} , $V_{refA} = V_{refB} = 10\text{ V}$, V_{OA} and V_{OB} at 0 V (unless otherwise noted)

PARAMETER		TEST CONDITIONS		MIN	TYP	MAX	UNIT
Linearity error						$\pm 1/2$	LSB
Settling time (to 1/2 LSB)		See Note 1				100	ns
Gain error		See Note 2	Full range			± 3	LSB
			25°C			± 2	
AC feedthrough	REFA to OUTA	See Note 3	Full range			-65	dB
	REFB to OUTB		25°C			-75	
Temperature coefficient of gain						± 0.0035	%FSR/°C
Propagation delay (from digital input to 90% of final analog output current)		See Note 4				80	ns
Channel-to-channel isolation	REFA to OUTB	See Note 5	25°C			80	dB
	REFB to OUTA	See Note 6	25°C			80	
Digital-to-analog glitch impulse area		Measured for code transition from 00000000 to 11111111, $T_A = 25^\circ\text{C}$				330	nV•s
Digital crosstalk		Measured for code transition from 00000000 to 11111111, $T_A = 25^\circ\text{C}$				60	nV•s
Harmonic distortion		$V_i = 6\text{ V}$, $f = 1\text{ kHz}$, $T_A = 25^\circ\text{C}$				-85	dB

- NOTES: 1. OUTA, OUTB load = 100 Ω , $C_{ext} = 13\text{ pF}$; \overline{WR} and \overline{CS} at 0 V; DB0–DB7 at 0 V to V_{DD} or V_{DD} to 0 V.
 2. Gain error is measured using an internal feedback resistor. Nominal full scale range (FSR) = $V_{ref} - 1\text{ LSB}$. Both DAC latches are loaded with 11111111.
 3. $V_{ref} = 20\text{ V}$ peak-to-peak, 10-kHz sine wave
 4. $V_{refA} = V_{refB} = 10\text{ V}$; OUTA/OUTB load = 100 Ω , $C_{ext} = 13\text{ pF}$; \overline{WR} and \overline{CS} at 0 V; DB0–DB7 at 0 V to V_{DD} or V_{DD} to 0 V.
 5. $V_{refA} = 20\text{ V}$ peak-to-peak, 10-kHz sine wave; $V_{refB} = 0$
 6. $V_{refB} = 20\text{ V}$ peak-to-peak, 10-kHz sine wave; $V_{refA} = 0$

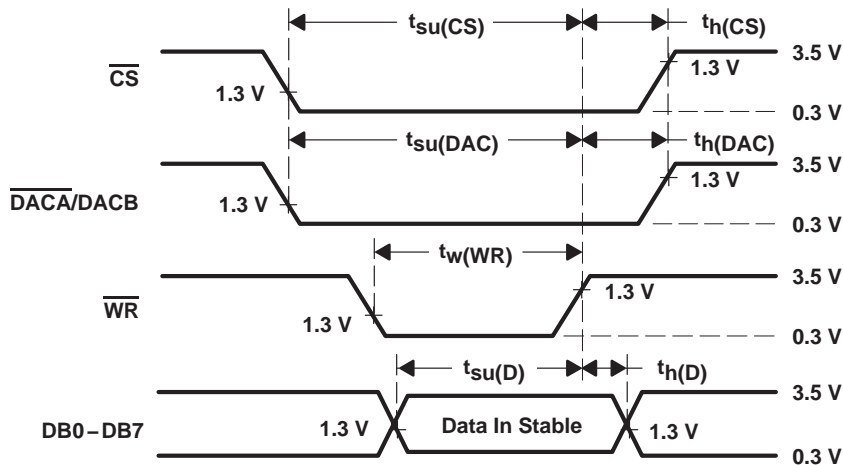

For all input signals, $t_r = t_f = 5\text{ ns}$ (10% to 90% points).

Figure 1. Setup and Hold Times



APPLICATION INFORMATION

This device is capable of performing 2-quadrant or full 4-quadrant multiplication. Circuit configurations for 2-quadrant and 4-quadrant multiplication are shown in Figures 2 and 3. Input coding for unipolar and bipolar operation are summarized in Tables 2 and 3, respectively.

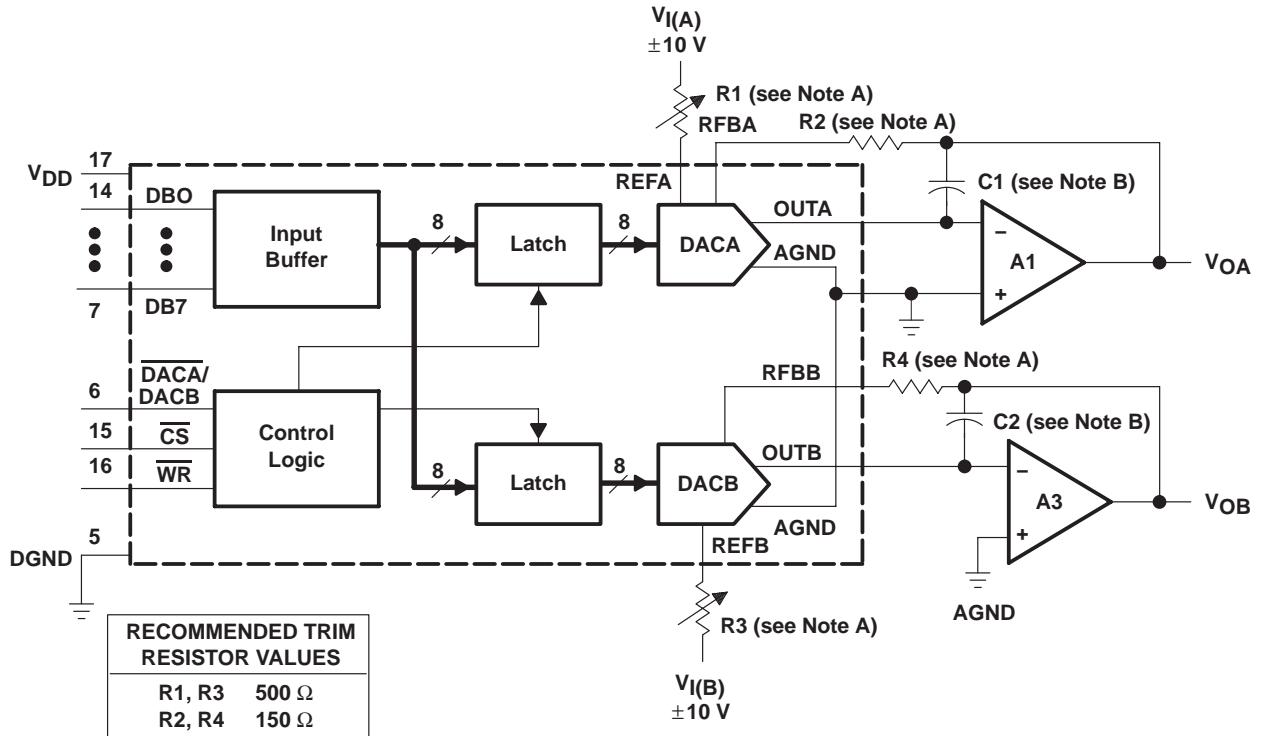

- NOTES: A. R1, R2, R3, and R4 are used only if gain adjustment is required. See table for recommended values. Make gain adjustment with digital input of 255.
- B. C1 and C2 phase compensation capacitors (10 pF to 15 pF) are required when using high-speed amplifiers to prevent ringing or oscillation.

Figure 2. Unipolar Operation (2-Quadrant Multiplication)

TLC7628C DUAL 8-BIT MULTIPLYING

SLAS063B – APRIL 1989 – REVISED MARCH 2007

APPLICATION INFORMATION

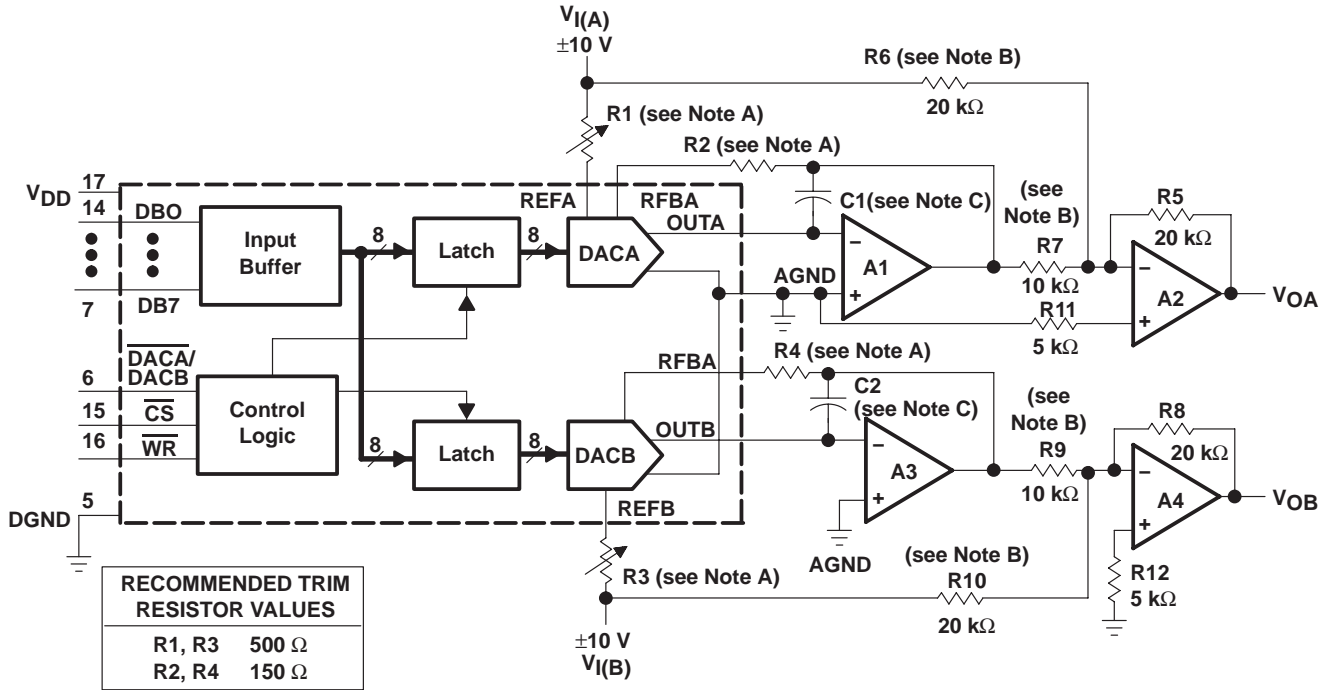

- NOTES: A. R1, R2, R3, and R4 are used only if gain adjustment is required. See table for recommended values. Adjust R1 for $V_{OA} = 0\text{ V}$ with code 10000000 in DACA latch. Adjust R3 for $V_{OB} = 0\text{ V}$ with 10000000 in DACB latch.
- B. Matching and tracking are essential for resistor pairs R6, R7, R9, and R10.
- C. C1 and C2 phase compensation capacitors (10 pF to 15 pF) may be required if A1 and A3 are high-speed amplifiers.

Figure 3. Bipolar Operation (4-Quadrant Operation)

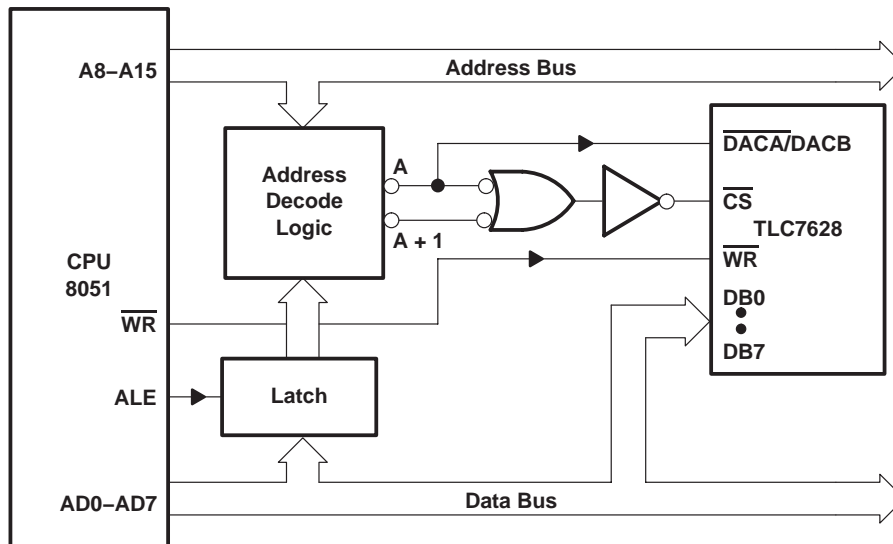

NOTE D: A = decoded address for TLC7628 DACA
A + 1 = decoded address for TLC7628 DACB

Figure 4. TLC7628 — Intel 8051 Interface

APPLICATION INFORMATION

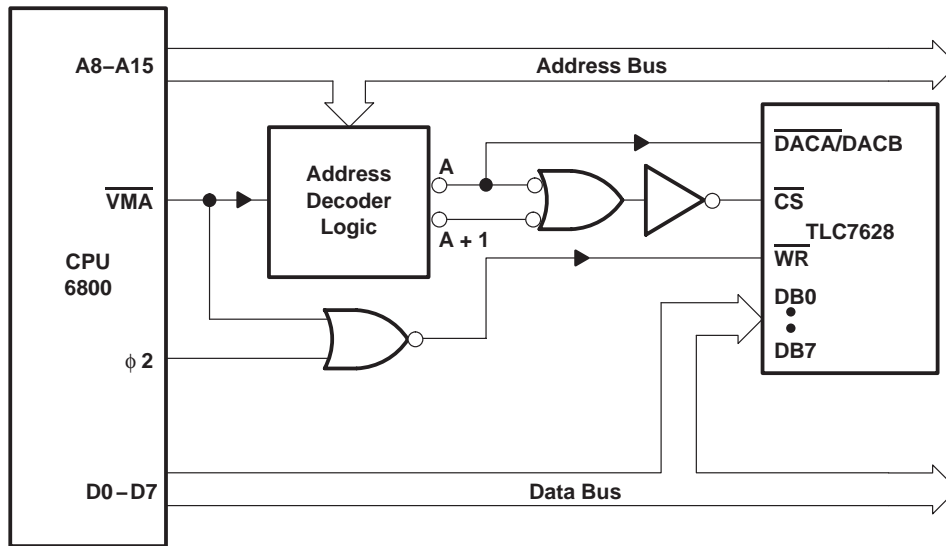

NOTE D: A = decoded address for TLC7628 DACA
A + 1 = decoded address for TLC7628 DACB

Figure 5. TLC7628 – 6800 Interface

voltage-mode operation

The current-multiplying DAC in the TLC7628C can be operated in a voltage mode. In the voltage mode, a fixed voltage is placed on the current output terminal. The analog output voltage is then available at the reference voltage terminal. An example of a current-multiplying DAC operating in voltage mode is shown in Figure 6. The relationship between the fixed input voltage and the analog output voltage is given by the following equation:

$$\text{Analog output voltage} = \text{fixed input voltage} (D/256)$$

where D = the digital input. In voltage-mode operation, these devices meet the following specification:

LINEARITY ERROR	TEST CONDITIONS	MIN	MAX	UNIT
Analog output voltage for REFA, REFB	$V_{DD} = 12\text{ V}$, OUTA or OUTB at 5 V , $T_A = 25^\circ\text{C}$		1	LSB

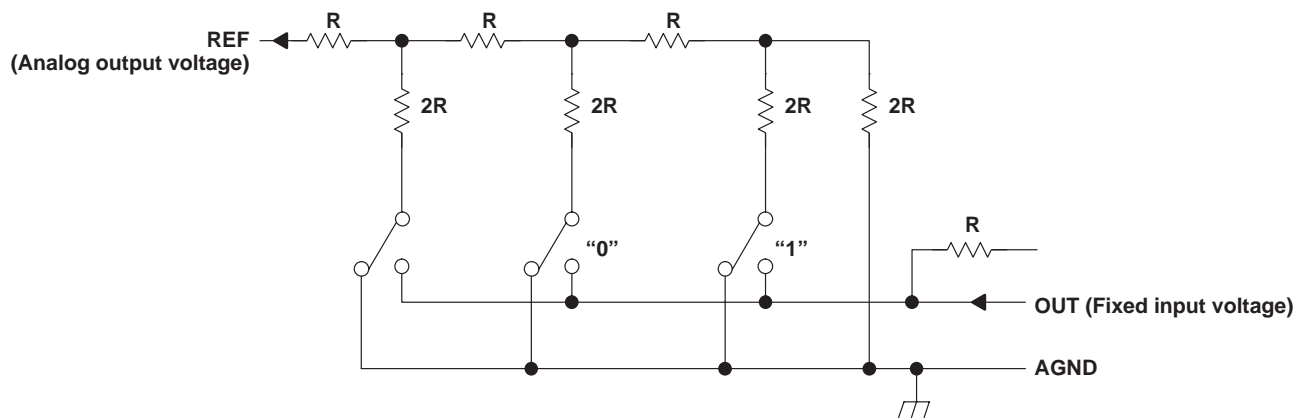

Figure 6. Current-Multiplying DAC Operating in Voltage Mode

TLC7628C

DUAL 8-BIT MULTIPLYING

SLAS063B – APRIL 1989 – REVISED MARCH 2007

PRINCIPLES OF OPERATION

This device contains two, identical, 8-bit, multiplying DACs: DACA and DACB. Each DAC consists of an inverted R-2R ladder, analog switches, and input data latches. Binary-weighted currents are switched between the DAC output and AGND, thus maintaining a constant current in each ladder leg independent of the switch state. Most applications require only the addition of an external operational amplifier and voltage reference. A simplified D/A circuit for DACA or DACB with all digital inputs low is shown in Figure 7.

Figure 8 shows the DACA or DACB equivalent circuit. Both DACs share the analog ground terminal 1 (AGND). With all digital inputs high, the reference current flows to OUTA. A small leakage current (I_{lkg}) flows across internal junctions, and as with most semiconductor devices, doubles every 10°C. The C_O is caused by the parallel combination of the NMOS switches and has a value that depends on the number of switches connected to the output. The range of C_O is 25 pF to 60 pF maximum. The equivalent output resistance (r_O) varies with the input code from 0.8R to 3R where R is the nominal value of the ladder resistor in the R-2R network.

The TLC7628C interfaces to a microprocessor through the data bus, \overline{CS} , \overline{WR} , and $\overline{DACA/DACB}$ control signals. When \overline{CS} and \overline{WR} are both low, the analog output on this device, specified by the $\overline{DACA/DACB}$ control line, responds to the activity on the DB0–DB7 data bus inputs. In this mode, the input latches are transparent and input data directly affects the analog output. When either the \overline{CS} signal or \overline{WR} signal goes high, the data on the DB0–DB7 inputs are latched until the \overline{CS} and \overline{WR} signals go low again. When \overline{CS} is high, the data inputs are disabled, regardless of the state of the \overline{WR} signal.

The digital inputs of the TLC7628C provides TTL compatibility when operated from a supply voltage of 10.8 V to 15.75 V.

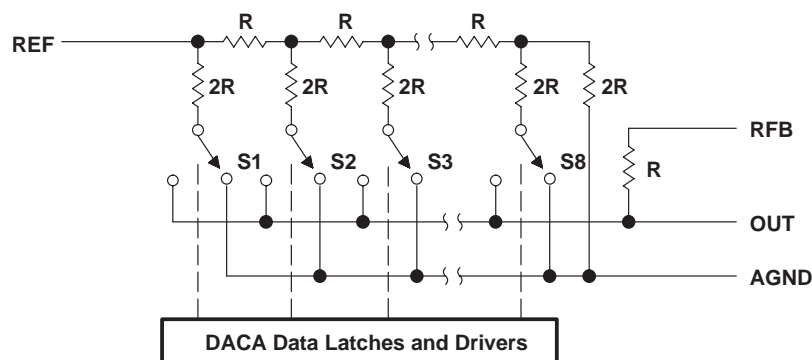

Figure 7. Simplified Functional Circuit for DACA or DACB

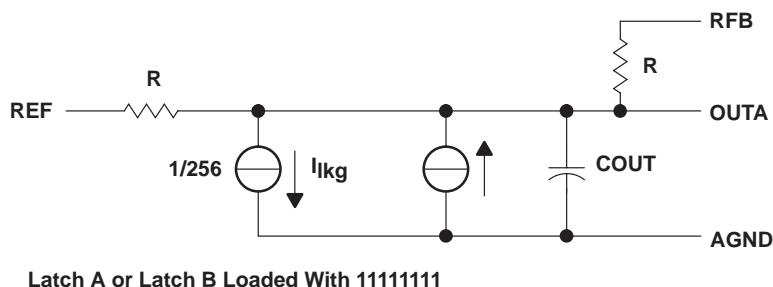

Figure 8. TLC7628 Equivalent Circuit for DACA or DACB

PRINCIPLES OF OPERATION

Table 1. Mode Selection Table

$\overline{\text{DACA/DACB}}$	$\overline{\text{CS}}$	$\overline{\text{WR}}$	DACA	DACB
L	L	L	Write	Hold
H	L	L	Hold	Write
X	H	X	Hold	Hold
X	X	H	Hold	Hold

L = low level, H = high level, X = don't care

Table 2. Unipolar Binary Code

DAC LATCH CONTENTS (see Note 7)		ANALOG OUTPUT
MSB	LSB	
1	1111111	$-V_I (255/256)$
1	0000001	$-V_I (129/256)$
1	0000000	$-V_I (128/256) = -V_I/2$
0	1111111	$-V_I (127/256)$
0	0000001	$-V_I (1/256)$
0	0000000	$-V_I (0/256) = 0$

Table 3. Bipolar (Offset Binary) Code

DAC LATCH CONTENTS (see Note 8)		ANALOG OUTPUT
MSB	LSB	
1	1111111	$V_I (127/128)$
1	0000001	$V_I (1/128)$
1	0000000	0 V
0	1111111	$-V_I (1/128)$
0	0000001	$-V_I (127/128)$
0	0000000	$-V_I (128/128)$

- NOTES: 7. 1 LSB = $(2^{-8})V_I$
 8. 1 LSB = $(2^{-7})V_I$

PACKAGING INFORMATION

Orderable Device	Status (1)	Package Type	Package Drawing	Pins	Package Qty	Eco Plan (2)	Lead finish/ Ball material (6)	MSL Peak Temp (3)	Op Temp (°C)	Device Marking (4/5)	Samples
TLC7628CDW	ACTIVE	SOIC	DW	20	25	RoHS & Green	NIPDAU	Level-1-260C-UNLIM	0 to 70	TLC7628C	Samples
TLC7628CDWR	ACTIVE	SOIC	DW	20	2000	RoHS & Green	NIPDAU	Level-1-260C-UNLIM	0 to 70	TLC7628C	Samples
TLC7628CN	ACTIVE	PDIP	N	20	20	RoHS & Non-Green	NIPDAU	N / A for Pkg Type	0 to 70	TLC7628CN	Samples

(1) The marketing status values are defined as follows:

ACTIVE: Product device recommended for new designs.

LIFEBUY: TI has announced that the device will be discontinued, and a lifetime-buy period is in effect.

NRND: Not recommended for new designs. Device is in production to support existing customers, but TI does not recommend using this part in a new design.

PREVIEW: Device has been announced but is not in production. Samples may or may not be available.

OBSOLETE: TI has discontinued the production of the device.

(2) **RoHS:** TI defines "RoHS" to mean semiconductor products that are compliant with the current EU RoHS requirements for all 10 RoHS substances, including the requirement that RoHS substance do not exceed 0.1% by weight in homogeneous materials. Where designed to be soldered at high temperatures, "RoHS" products are suitable for use in specified lead-free processes. TI may reference these types of products as "Pb-Free".

RoHS Exempt: TI defines "RoHS Exempt" to mean products that contain lead but are compliant with EU RoHS pursuant to a specific EU RoHS exemption.

Green: TI defines "Green" to mean the content of Chlorine (Cl) and Bromine (Br) based flame retardants meet JS709B low halogen requirements of <=1000ppm threshold. Antimony trioxide based flame retardants must also meet the <=1000ppm threshold requirement.

(3) MSL, Peak Temp. - The Moisture Sensitivity Level rating according to the JEDEC industry standard classifications, and peak solder temperature.

(4) There may be additional marking, which relates to the logo, the lot trace code information, or the environmental category on the device.

(5) Multiple Device Markings will be inside parentheses. Only one Device Marking contained in parentheses and separated by a "~" will appear on a device. If a line is indented then it is a continuation of the previous line and the two combined represent the entire Device Marking for that device.

(6) Lead finish/Ball material - Orderable Devices may have multiple material finish options. Finish options are separated by a vertical ruled line. Lead finish/Ball material values may wrap to two lines if the finish value exceeds the maximum column width.

Important Information and Disclaimer:The information provided on this page represents TI's knowledge and belief as of the date that it is provided. TI bases its knowledge and belief on information provided by third parties, and makes no representation or warranty as to the accuracy of such information. Efforts are underway to better integrate information from third parties. TI has taken and continues to take reasonable steps to provide representative and accurate information but may not have conducted destructive testing or chemical analysis on incoming materials and chemicals. TI and TI suppliers consider certain information to be proprietary, and thus CAS numbers and other limited information may not be available for release.

In no event shall TI's liability arising out of such information exceed the total purchase price of the TI part(s) at issue in this document sold by TI to Customer on an annual basis.

TAPE AND REEL INFORMATION

QUADRANT ASSIGNMENTS FOR PIN 1 ORIENTATION IN TAPE

*All dimensions are nominal

Device	Package Type	Package Drawing	Pins	SPQ	Reel Diameter (mm)	Reel Width W1 (mm)	A0 (mm)	B0 (mm)	K0 (mm)	P1 (mm)	W (mm)	Pin1 Quadrant
TLC7628CDWR	SOIC	DW	20	2000	330.0	24.4	10.8	13.3	2.7	12.0	24.0	Q1

TAPE AND REEL BOX DIMENSIONS

*All dimensions are nominal

Device	Package Type	Package Drawing	Pins	SPQ	Length (mm)	Width (mm)	Height (mm)
TLC7628CDWR	SOIC	DW	20	2000	350.0	350.0	43.0

TUBE

*All dimensions are nominal

Device	Package Name	Package Type	Pins	SPQ	L (mm)	W (mm)	T (μm)	B (mm)
TLC7628CDW	DW	SOIC	20	25	506.98	12.7	4826	6.6
TLC7628CN	N	PDIP	20	20	506	13.97	11230	4.32

N (R-PDIP-T**)

PLASTIC DUAL-IN-LINE PACKAGE

16 PINS SHOWN



- NOTES:
- A. All linear dimensions are in inches (millimeters).
 - B. This drawing is subject to change without notice.
 - Falls within JEDEC MS-001, except 18 and 20 pin minimum body length (Dim A).
 - The 20 pin end lead shoulder width is a vendor option, either half or full width.

DW0020A



PACKAGE OUTLINE

SOIC - 2.65 mm max height

SOIC



4220724/A 05/2016

NOTES:

1. All linear dimensions are in millimeters. Dimensions in parenthesis are for reference only. Dimensioning and tolerancing per ASME Y14.5M.
2. This drawing is subject to change without notice.
3. This dimension does not include mold flash, protrusions, or gate burrs. Mold flash, protrusions, or gate burrs shall not exceed 0.15 mm per side.
4. This dimension does not include interlead flash. Interlead flash shall not exceed 0.43 mm per side.
5. Reference JEDEC registration MS-013.

EXAMPLE BOARD LAYOUT

DW0020A

SOIC - 2.65 mm max height

SOIC



LAND PATTERN EXAMPLE
SCALE:6X



SOLDER MASK DETAILS

4220724/A 05/2016

NOTES: (continued)

- 6. Publication IPC-7351 may have alternate designs.
- 7. Solder mask tolerances between and around signal pads can vary based on board fabrication site.

EXAMPLE STENCIL DESIGN

DW0020A

SOIC - 2.65 mm max height

SOIC



SOLDER PASTE EXAMPLE
BASED ON 0.125 mm THICK STENCIL
SCALE:6X

4220724/A 05/2016

NOTES: (continued)

8. Laser cutting apertures with trapezoidal walls and rounded corners may offer better paste release. IPC-7525 may have alternate design recommendations.
9. Board assembly site may have different recommendations for stencil design.

IMPORTANT NOTICE AND DISCLAIMER

TI PROVIDES TECHNICAL AND RELIABILITY DATA (INCLUDING DATA SHEETS), DESIGN RESOURCES (INCLUDING REFERENCE DESIGNS), APPLICATION OR OTHER DESIGN ADVICE, WEB TOOLS, SAFETY INFORMATION, AND OTHER RESOURCES "AS IS" AND WITH ALL FAULTS, AND DISCLAIMS ALL WARRANTIES, EXPRESS AND IMPLIED, INCLUDING WITHOUT LIMITATION ANY IMPLIED WARRANTIES OF MERCHANTABILITY, FITNESS FOR A PARTICULAR PURPOSE OR NON-INFRINGEMENT OF THIRD PARTY INTELLECTUAL PROPERTY RIGHTS.

These resources are intended for skilled developers designing with TI products. You are solely responsible for (1) selecting the appropriate TI products for your application, (2) designing, validating and testing your application, and (3) ensuring your application meets applicable standards, and any other safety, security, regulatory or other requirements.

These resources are subject to change without notice. TI grants you permission to use these resources only for development of an application that uses the TI products described in the resource. Other reproduction and display of these resources is prohibited. No license is granted to any other TI intellectual property right or to any third party intellectual property right. TI disclaims responsibility for, and you will fully indemnify TI and its representatives against, any claims, damages, costs, losses, and liabilities arising out of your use of these resources.

TI's products are provided subject to [TI's Terms of Sale](#) or other applicable terms available either on ti.com or provided in conjunction with such TI products. TI's provision of these resources does not expand or otherwise alter TI's applicable warranties or warranty disclaimers for TI products.

TI objects to and rejects any additional or different terms you may have proposed.

Mailing Address: Texas Instruments, Post Office Box 655303, Dallas, Texas 75265
Copyright © 2022, Texas Instruments Incorporated