

TPS2HB16-Q1 40V、16mΩ 双通道智能高侧开关

1 特性

- 符合汽车类应用要求
- 具有符合 AEC-Q100 标准的下列特性：
 - 器件温度等级 1：环境工作温度范围 $T_A = -40^{\circ}\text{C}$ 至 125°C
 - 器件 HBM ESD 分类等级 2
 - 器件 CDM ESD 分类等级 C4B
 - 可承受 40V 负载突降
- 具有 $16\text{m}\Omega$ R_{ON} ($T_J = 25^{\circ}\text{C}$) 的双通道智能高侧开关
- 通过可调电流限制提高系统级可靠性
 - 电流限制可调范围为 4.1A 至 48.5A，并且内部固定为 60A
- 强大的集成输出保护：
 - 集成热保护
 - 接地短路或电池短路保护
 - 反向电池事件保护包括电压反向时自动启动
 - 发生失电或接地失效时自动关闭
 - 集成输出钳位对电感负载进行消磁
 - 可配置故障处理
- 可对模拟检测输出进行配置，以精确测量：
 - 负载电流
 - 器件温度
- 通过 SNS 引脚提供故障指示
 - 开路负载和电池短路检测

2 应用

- 汽车显示模块
- ADAS 模块
- 座椅舒适模块
- 变速器控制单元
- HVAC 控制模块
- 车身控制模块
- LED 照明
- 2x27W 灯泡

3 说明

TPS2HB16-Q1 器件是一款适用于 12V 汽车系统的双通道智能高侧开关。该器件集成了强大的保护和诊断功能，以确保即使在汽车系统中发生短路等有害事件时也能提供输出端口保护。该器件通过可靠的电流限制来防止故障，根据器件型号不同，电流限制可调范围为 4.1A 至 48.5A。TPS2HB16F-Q1 器件具有高达 60A 的固定电流限制，能够驱动 2x35W、2x27W 和 2x21W 灯泡。

凭借较高的电流限制范围，该器件可用于需要大瞬态电流的负载，而低电流限制范围可为不需要高电流的负载提供更好的保护。该器件能够可靠地驱动各种负载分布。

TPS2HB16-Q1 还能够提供可改进负载诊断的高精度模拟电流检测。通过向系统 MCU 报告负载电流和器件温度，该器件可实现预测性维护和负载诊断，从而延长系统寿命。

TPS2HB16-Q1 采用 HTSSOP 封装，可减小 PCB 尺寸。

器件信息⁽¹⁾

器件型号	封装	封装尺寸 (标称值)
TPS2HB16-Q1	HTSSOP (16)	5.00mm x 4.40mm

(1) 如需了解所有可用封装，请参阅数据表末尾的可订购产品附录。

简化原理图

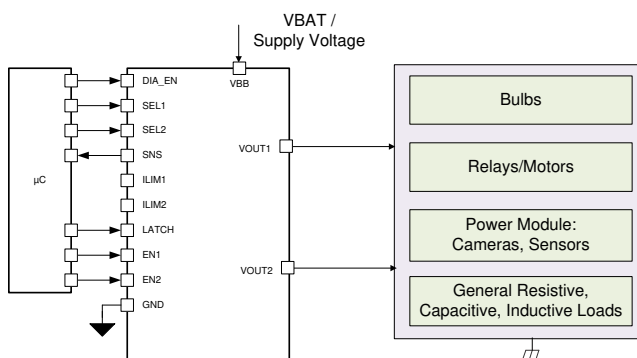

目录

1	特性	1	9.2	Functional Block Diagram	20
2	应用	1	9.3	Feature Description	21
3	说明	1	9.4	Device Functional Modes	33
4	修订历史记录	2	10	Application and Implementation	35
5	Device Comparison Table	3	10.1	Application Information	35
6	Pin Configuration and Functions	4	10.2	Typical Application	38
6.1	Recommended Connections for Unused Pins	5	10.3	Typical Application	42
7	Specifications	6	11	Power Supply Recommendations	46
7.1	Absolute Maximum Ratings	6	12	Layout	48
7.2	ESD Ratings	6	12.1	Layout Guidelines	48
7.3	Recommended Operating Conditions	6	12.2	Layout Example	48
7.4	Thermal Information	7	13	器件和文档支持	49
7.5	Electrical Characteristics	7	13.1	文档支持	49
7.6	SNS Timing Characteristics	9	13.2	接收文档更新通知	49
7.7	Switching Characteristics	10	13.3	支持资源	49
7.8	Typical Characteristics	13	13.4	商标	49
8	Parameter Measurement Information	18	13.5	静电放电警告	49
9	Detailed Description	19	13.6	Glossary	49
9.1	Overview	19	14	机械、封装和可订购信息	49

4 修订历史记录

Changes from Revision B (November 2019) to Revision C		Page
•	Added Device Version F	3

Changes from Revision A (April 2019) to Revision B		Page
•	将“预告信息”更改为“生产数据”	1

5 Device Comparison Table

Table 1. TPS2HB16-Q1 Device Options

Device Version	Part Number	Orderable Part Number	Current Limit	Current Limit Range	Overcurrent Behavior
A	TPS2HB16A-Q1	TPS2HB16AQPWPR Q1	Resistor Programmable	4.1 A - 22 A	Disable switch immediately
B	TPS2HB16B-Q1	TPS2HB16BQPWPR Q1	Resistor Programmable	10.3 A - 48.5 A	Disable switch immediately
F	TPS2HB16F-Q1	TPS2HB16FQPWPR Q1	Internally Set	60 A	Disable switch immediately

6 Pin Configuration and Functions

**PWP Package (Version A/B)
16-Pin HTSSOP
Top View**

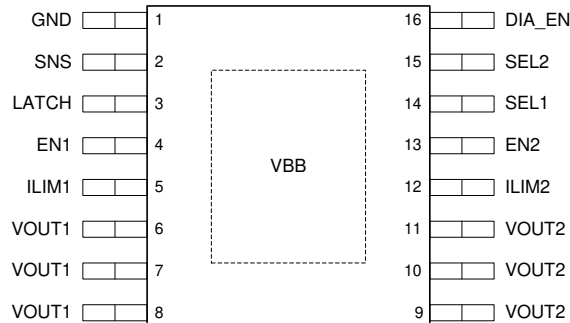

**PWP Package (Version F)
16-Pin HTSSOP
Top View**

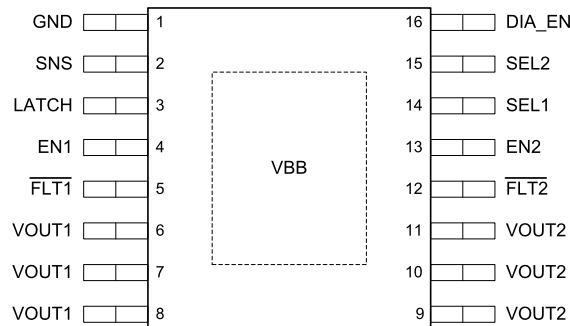

Pin Functions

NO.	PIN		I/O	DESCRIPTION
	Version A/B	Version F		
GND	1	1	-	Device ground
SNS	2	2	O	Sense output
LATCH	3	3	I	Sets fault handling behavior (latched or auto-retry)
EN1	4	4	I	Channel 1 control input, active high
ILIM1	5	-	O	Connect pull-up resistor to V_{BB} to set current-limit threshold on CH1
$\overline{FLT1}$	-	5	O	Open drain fault indication
VOUT1	6-8	6-8	O	Channel 1 output
VOUT2	9-11	9-11	O	Channel 2 output
ILIM2	12	-	O	Connect pull-up resistor to V_{BB} to set current-limit threshold on CH2
$\overline{FLT2}$	-	12	O	Open drain fault indication
EN2	13	13	I	Channel 2 control input, active high
SEL1	14	14	I	Diagnostics select 1. No functionality on version F; tie to device ground through 10 k Ω resistor
SEL2	15	15	I	Diagnostics select 2
DIA_EN	16	16	I	Diagnostic enable, active high
VBB	Exposed Pad	Exposed Pad	I	Power supply input

6.1 Recommended Connections for Unused Pins

The TPS2HB16-Q1 device is designed to provide an enhanced set of diagnostic and protection features. However, if the system design only allows for a limited number of I/O connections, some pins may be considered optional.

Table 2. Connections for Optional Pins

PIN NAME	CONNECTION IF NOT USED	IMPACT IF NOT USED
SNS	Ground through 1-kΩ resistor	Analog sense is not available.
LATCH	Float or ground through R_{PROT} resistor	With LATCH unused, the device will auto-retry after a fault. If latched behavior is desired, but the system describes limited I/O, it is possible to use one microcontroller output to control the latch function of several high-side channels.
ILIM1, ILIM2	Float	If the ILIMx pin is left floating, the device will be set to the default internal current-limit threshold.
SEL1	Float or ground through R_{PROT} resistor	SEL1 selects the T_J sensing feature. With SEL1 unused, only CH1 and CH2 current sensing and open load detection are available.
SEL2	Ground through R_{PROT} resistor	With SEL2 = 0 V, CH2 current sensing and CH2 open load detection are not available.
$\overline{\text{FLT1}}$, $\overline{\text{FLT2}}$ (Version F)	Float	If the $\overline{\text{FLT}}$ pin is unused, the system cannot read faults from the output.
DIA_EN	Float or ground through R_{PROT} resistor	With DIA_EN unused, the analog sense, open-load, and short-to-battery diagnostics are not available.

R_{PROT} is used to protect the pins from excess current flow during reverse battery conditions, for more information see the section on [Reverse Battery](#) protection.

7 Specifications

7.1 Absolute Maximum Ratings

Over operating free-air temperature range (unless otherwise noted)⁽¹⁾

		MIN	MAX	UNIT
Maximum continuous supply voltage, V_{BB}			36	V
Load dump voltage, V_{LD}	ISO16750-2:2010(E)		40	V
Reverse battery voltage, V_{Rev} , $t \leq 3$ minutes		-18		V
Enable pin voltage, V_{EN1} and V_{EN2}		-1	7	V
LATCH pin voltage, V_{LATCH}		-1	7	V
Diagnostic Enable pin voltage, V_{DIA_EN}		-1	7	V
Sense pin voltage, V_{SNS}		-1	18	V
Select pin voltage, V_{SEL1} and V_{SEL2}		-1	7	V
Reverse ground current, I_{GND}	$V_{BB} < 0$ V		-50	mA
Energy dissipation during turnoff, E_{TOFF}	Single pulse, one channel, $L_{OUT} = 5$ mH, $T_{J,start} = 125^\circ\text{C}$		50 ⁽²⁾	mJ
Energy dissipation during turnoff, E_{TOFF}	Repetitive pulse, one channel, $L_{OUT} = 5$ mH, $T_{J,start} = 125^\circ\text{C}$		13 ⁽²⁾	mJ
Maximum junction temperature, T_J			150	$^\circ\text{C}$
Storage temperature, T_{stg}		-65	150	$^\circ\text{C}$

- (1) Stresses beyond those listed under *Absolute Maximum Ratings* may cause permanent damage to the device. These are stress ratings only, which do not imply functional operation of the device at these or any other conditions beyond those indicated under *Recommended Operating Conditions*. Exposure to absolute maximum rated conditions for extended periods may affect device reliability.
- (2) For further details, see the section regarding switch-off of an inductive load.

7.2 ESD Ratings

			VALUE	UNIT
$V_{(ESD)}$	Electrostatic discharge	Human-body model (HBM), per AEC Q100-002 ⁽¹⁾	± 2000	V
			± 4000	
		Charged-device model (CDM), per AEC Q100-011	± 750	

- (1) AEC-Q100-002 indicates that HBM stressing shall be in accordance with the ANSI/ESDA/JEDEC JS-001 specifications.

7.3 Recommended Operating Conditions

over operating free-air temperature range (unless otherwise noted)⁽¹⁾

		MIN	MAX	UNIT
V_{BB}	Nominal supply voltage ⁽¹⁾	6	18	V
V_{BB}	Extended supply voltage ⁽²⁾	3	28	V
V_{EN1} , V_{EN2}	Enable voltage	-1	5.5	V
V_{LATCH}	LATCH voltage	-1	5.5	V
V_{DIA_EN}	Diagnostic Enable voltage	-1	5.5	V
V_{SEL1} , V_{SEL2}	Select voltage	-1	5.5	V
V_{SNS}	Sense voltage	-1	7	V
T_A	Operating free-air temperature	-40	125	$^\circ\text{C}$

- (1) All operating voltage conditions are measured with respect to device GND
- (2) Device will function within extended operating range, however some parametric values might not apply

7.4 Thermal Information

THERMAL METRIC ⁽¹⁾ (2)		TPS2HB16-Q1	UNIT
		PWP (HTSSOP)	
		16 PINS	
$R_{\theta JA}$	Junction-to-ambient thermal resistance	32.9	°C/W
$R_{\theta JC(top)}$	Junction-to-case (top) thermal resistance	30.8	°C/W
$R_{\theta JB}$	Junction-to-board thermal resistance	9.0	°C/W
Ψ_{JT}	Junction-to-top characterization parameter	1.8	°C/W
Ψ_{JB}	Junction-to-board characterization parameter	9.2	°C/W
$R_{\theta JC(bot)}$	Junction-to-case (bottom) thermal resistance	2.0	°C/W

(1) For more information about traditional and new thermal metrics, see the [Semiconductor and IC Package Thermal Metrics](#) application report.

(2) The thermal parameters are based on a 4-layer PCB according to the JESD51-5 and JESD51-7 standards.

7.5 Electrical Characteristics

$V_{BB} = 6\text{ V to }18\text{ V}$, $T_J = -40^\circ\text{C to }150^\circ\text{C}$ (unless otherwise noted)

PARAMETER		TEST CONDITIONS	MIN	TYP	MAX	UNIT
INPUT VOLTAGE AND CURRENT						
$V_{DSClamp}$	V_{DS} clamp voltage		40		46	V
$V_{BBClamp}$	V_{BB} clamp voltage		58		76	V
V_{UVLOF}	V_{BB} undervoltage lockout falling	Measured with respect to the GND pin of the device	2.0		3	V
V_{UVLOR}	V_{BB} undervoltage lockout rising	Measured with respect to the GND pin of the device	2.2		3	V
I_{SB}	Standby current (total device leakage including both MOSFET channels)	$V_{BB} = 13.5\text{ V}$, $T_J = 25^\circ\text{C}$ $V_{ENx} = V_{DIA_EN} = 0\text{ V}$, $V_{OUT} = 0\text{ V}$			0.5	μA
		$V_{BB} = 13.5\text{ V}$, $T_J = 125^\circ\text{C}$, $V_{ENx} = V_{DIA_EN} = 0\text{ V}$, $V_{OUT} = 0\text{ V}$			4	μA
I_{L_NOM}	Continuous load current, per channel	Two channels enabled, $T_{AMB} = 70^\circ\text{C}$		5		A
		One channel enabled, $T_{AMB} = 70^\circ\text{C}$		7		A
$I_{OUT(standby)}$	Output leakage current (per channel)	$V_{BB} = 13.5\text{ V}$, $T_J = 25^\circ\text{C}$ $V_{ENx} = V_{DIA_EN} = 0\text{ V}$, $V_{OUT} = 0\text{ V}$		0.01	0.5	μA
		$V_{BB} = 13.5\text{ V}$, $T_J = 125^\circ\text{C}$ $V_{ENx} = V_{DIA_EN} = 0\text{ V}$, $V_{OUT} = 0\text{ V}$			1.5	μA
I_{DIA}	Current consumption in diagnostic mode	$V_{BB} = 13.5\text{ V}$, $I_{SNS} = 0\text{ mA}$ $V_{ENx} = 0\text{ V}$, $V_{DIA_EN} = 5\text{ V}$, $V_{OUT} = 0\text{ V}$		3	6	mA
I_Q	Quiescent current	$V_{BB} = 13.5\text{ V}$ $V_{ENx} = V_{DIA_EN} = 5\text{ V}$, $I_{OUTx} = 0\text{ A}$		3	6	mA
t_{STBY}	Standby mode delay time	$V_{ENx} = V_{DIA_EN} = 0\text{ V}$ to standby	12	17	22	ms
RON CHARACTERISTICS						
R_{ON}	On-resistance (Includes MOSFET and package)	$T_J = 25^\circ\text{C}$, $6\text{ V} \leq V_{BB} \leq 28\text{ V}$, $I_{OUT1} = I_{OUT2} > 1\text{ A}$		16		$\text{m}\Omega$
		$T_J = 150^\circ\text{C}$, $6\text{ V} \leq V_{BB} \leq 28\text{ V}$, $I_{OUT1} = I_{OUT2} > 1\text{ A}$			40	$\text{m}\Omega$
		$T_J = 25^\circ\text{C}$, $3\text{ V} \leq V_{BB} \leq 6\text{ V}$, $I_{OUT1} = I_{OUT2} > 1\text{ A}$			30	$\text{m}\Omega$
$R_{ON(REV)}$	On-resistance during reverse polarity	$T_J = 25^\circ\text{C}$, $-18\text{ V} \leq V_{BB} \leq -8\text{ V}$		16		$\text{m}\Omega$
		$T_J = 105^\circ\text{C}$, $-18\text{ V} \leq V_{BB} \leq -8\text{ V}$			40	$\text{m}\Omega$
CURRENT SENSE CHARACTERISTICS						
K_{SNS}	Current sense ratio I_{OUTx} / I_{SNS}	$I_{OUTx} = 1\text{ A}$		3000		

Electrical Characteristics (continued)

V_{BB} = 6 V to 18 V, T_J = -40°C to 150°C (unless otherwise noted)

PARAMETER		TEST CONDITIONS		MIN	TYP	MAX	UNIT
I _{SNSI}	Current sense current and accuracy	V _{EN} = V _{DIA_EN} = 5 V, V _{SEL1} = 0 V, V _{SEL2} = X	I _{OUT} = 6 A		2.000		mA
					-5		5.3
			I _{OUT} = 3 A		1.000		mA
					-5		5.3
			I _{OUT} = 1 A		0.333		mA
					-5		5.3
			I _{OUT} = 300 mA		0.1		mA
					-6		6.3
I _{OUT} = 100 mA		0.0322		mA			
		-9		9.6	%		
I _{OUT} = 50 mA		0.0154		mA			
		-19.5		18.7	%		
I _{OUT} = 20 mA		0.0054		mA			
		-59.3		53.1	%		
TJ SENSE CHARACTERISTICS							
I _{SNST}	Temperature sense current Device Version A/B	V _{DIA_EN} = 5 V, V _{SEL1} = 5 V, V _{SEL2} = 0 V	T _J = -40°C	0.00	0.12	0.29	mA
			T _J = 25°C	0.68	0.85	1.02	mA
			T _J = 85°C	1.25	1.52	1.79	mA
			T _J = 125°C	1.61	1.96	2.31	mA
			T _J = 150°C	1.80	2.25	2.70	mA
dI _{SNST} /dT	Coefficient			0.011			mA/°C
SNS CHARACTERISTICS							
I _{SNSFH}	I _{SNS} fault high-level	V _{DIA_EN} = 5 V, V _{SEL1} = 0 V, V _{SEL2} = X		4	4.5	5.3	mA
I _{SNSleak}	I _{SNS} leakage	V _{DIA_EN} = 0 V				1	µA
CURRENT LIMIT CHARACTERISTICS							
I _{CL}	Current Limit Threshold	Device Version A, T _J = -40°C to 150°C	R _{LIM} = GND, open, or out of range		29.1		A
			R _{LIM} = 5 kΩ	17.4	22	29.3	A
			R _{LIM} = 25 kΩ	2.66	4.1	5.46	A
		Device Version B, T _J = -40°C to 150°C	R _{LIM} = GND, open, or out of range		67.5		A
			R _{LIM} = 5 kΩ	38	48.5	65	A
			R _{LIM} = 25 kΩ	8.1	10.3	13.7	A
		Device Version F	T _J = -40°C to 60°C	51.65	60	76.32	A
			T _J = 150°C	42.16	48.00	57.60	A
		K _{CL}	Current Limit Ratio	Version A		102	
Version B				258			A * kΩ
FAULT CHARACTERISTICS							
V _{OL}	Open-load (OL) detection voltage	V _{ENx} = 0 V, V _{DIA_EN} = 5 V		2	3	4	V
t _{OL1}	OL and STB indication-time from ENx falling	V _{ENx} = 5 V to 0 V, V _{DIA_EN} = 5 V, V _{SEL1} = 0 V ⁽¹⁾ I _{OUT} = 0 mA, V _{OUTx} = 4 V		300	500	700	µs
t _{OL2}	OL and STB indication-time from DIA_EN rising	V _{ENx} = 0 V, V _{DIA_EN} = 0 V to 5 V, V _{SEL1} = 0 V ⁽¹⁾ I _{OUT} = 0 mA, V _{OUTx} = 4 V				50	µs
t _{OL3}	OL and STB indication-time from V _{OUT} rising	V _{ENx} = 0 V, V _{DIA_EN} = 5 V, V _{SEL1} = 0 V ⁽¹⁾ I _{OUT} = 0 mA, V _{OUTx} = 0 V to 4 V				50	µs

(1) SELx must be set to select the relevant channel. Diagnostics are performed on Channel 1 when SELx = 00 and diagnostics are performed on channel 2 when SELx = 01

Electrical Characteristics (continued)

 $V_{BB} = 6\text{ V to }18\text{ V}$, $T_J = -40^\circ\text{C to }150^\circ\text{C}$ (unless otherwise noted)

PARAMETER		TEST CONDITIONS	MIN	TYP	MAX	UNIT
T_{ABS}	Thermal shutdown		150			$^\circ\text{C}$
T_{REL}	Relative thermal shutdown			50		$^\circ\text{C}$
T_{HYS}	Thermal shutdown hysteresis			28		$^\circ\text{C}$
t_{FAULT}	Fault shutdown indication-time	$V_{DIA_EN} = 5\text{ V}$ Time between switch shutdown and I_{SNS} settling at I_{SNSFH}			50	μs
t_{RETRY}	Retry time	Time from fault shutdown until switch re-enable (thermal shutdown or current limit).	1	2	3	ms
EN1 AND EN2 PIN CHARACTERISTICS⁽²⁾						
V_{IL_ENx}	Input voltage low-level	No GND network diode			0.8	V
V_{IH_ENx}	Input voltage high-level	No GND network diode	2			V
V_{IHYS_ENx}	Input voltage hysteresis			350		mV
R_{ENx}	Internal pulldown resistor		0.5	1	2	$\text{M}\Omega$
I_{IL_EN}	Input current low-level	$V_{EN} = 0.8\text{ V}$		0.8		μA
I_{IH_EN}	Input current high-level	$V_{EN} = 5\text{ V}$		5		μA
DIA_EN PIN CHARACTERISTICS⁽²⁾						
$V_{IL_DIA_EN}$	Input voltage low-level	No GND network diode			0.8	V
$V_{IH_DIA_EN}$	Input voltage high-level	No GND network diode	2.0			V
$V_{IHYS_DIA_EN}$	Input voltage hysteresis			350		mV
R_{DIA_EN}	Internal pulldown resistor		0.5	1	2	$\text{M}\Omega$
$I_{IL_DIA_EN}$	Input current low-level	$V_{DIA_EN} = 0.8\text{ V}$		0.8		μA
$I_{IH_DIA_EN}$	Input current high-level	$V_{DIA_EN} = 5\text{ V}$		5.0		μA
SEL1 AND SEL2 PIN Characteristics						
V_{IL_SELx}	Input voltage low-level	No GND network diode			0.8	V
V_{IH_SELx}	Input voltage high-level	No GND network diode	2			V
V_{IHYS_SELx}	Input voltage hysteresis			350		mV
R_{SELx}	Internal pulldown resistor		0.5	1	2	$\text{M}\Omega$
I_{IL_SELx}	Input current low-level	$V_{SELx} = 0.8\text{ V}$		0.8		μA
I_{IH_SELx}	Input current high-level	$V_{SELx} = 5\text{ V}$		5		μA
LATCH PIN CHARACTERISTICS⁽²⁾						
V_{IL_LATCH}	Input voltage low-level	No GND network diode			0.8	V
V_{IH_LATCH}	Input voltage high-level	No GND network diode	2.0			V
V_{IHYS_LATCH}	Input voltage hysteresis			350		mV
R_{LATCH}	Internal pulldown resistor		0.5	1	2	$\text{M}\Omega$
I_{IL_LATCH}	Input current low-level	$V_{LATCH} = 0.8\text{ V}$		0.8		μA
I_{IH_LATCH}	Input current high-level	$V_{LATCH} = 5\text{ V}$		5.0		μA

(2) $V_{BB} = 3\text{ V to }28\text{ V}$

7.6 SNS Timing Characteristics

 $V_{BB} = 6\text{ V to }18\text{ V}$, $T_J = -40^\circ\text{C to }+150^\circ\text{C}$ (unless otherwise noted)

PARAMETER		TEST CONDITIONS	MIN	TYP	MAX	UNIT
SNS TIMING - CURRENT SENSE						
$t_{SNSION1}$	Settling time from rising edge of DIA_EN	$V_{ENx} = 5\text{ V}$, $V_{DIA_EN} = 0\text{ V to }5\text{ V}$ $R_{SNS} = 1\text{ k}\Omega$, $R_L \leq 4\ \Omega$			40	μs

SNS Timing Characteristics (continued)

 $V_{BB} = 6\text{ V to }18\text{ V}$, $T_J = -40^\circ\text{C to }+150^\circ\text{C}$ (unless otherwise noted)

PARAMETER		TEST CONDITIONS	MIN	TYP	MAX	UNIT
t_{SNSION2}	Settling time from rising edge of ENx and DIA_EN	$V_{\text{ENx}} = V_{\text{DIA_EN}} = 0\text{ V to }5\text{ V}$ $R_{\text{SNS}} = 1\text{ k}\Omega$, $R_L \leq 4\ \Omega$			165	μs
t_{SNSION3}	Settling time from rising edge of ENx	$V_{\text{ENx}} = 0\text{ V to }5\text{ V}$, $V_{\text{DIA_EN}} = 5\text{ V}$ $R_{\text{SNS}} = 1\text{ k}\Omega$, $R_L \leq 4\ \Omega$			165	μs
t_{SNSIOFF1}	Settling time from falling edge of DIA_EN	$V_{\text{ENx}} = 5\text{ V}$, $V_{\text{DIA_EN}} = 5\text{ V to }0\text{ V}$ $R_{\text{SNS}} = 1\text{ k}\Omega$, $R_L \leq 4\ \Omega$			20	μs
t_{SETTLEH}	Settling time from rising edge of load step	$V_{\text{ENx}} = 5\text{ V}$, $V_{\text{DIA_EN}} = 5\text{ V}$ $R_{\text{SNS}} = 1\text{ k}\Omega$, $I_{\text{OUT}} = 5\text{ A to }1\text{ A}$			20	μs
t_{SETTLEL}	Settling time from falling edge of load step	$V_{\text{ENx}} = 5\text{ V}$, $V_{\text{DIA_EN}} = 5\text{ V}$ $R_{\text{SNS}} = 1\text{ k}\Omega$, $I_{\text{OUT}} = 5\text{ A to }1\text{ A}$			20	μs
SNS TIMING - TEMPERATURE SENSE						
t_{SNSTON1}	Settling time from rising edge of DIA_EN	$V_{\text{ENx}} = 5\text{ V}$, $V_{\text{DIA_EN}} = 0\text{ V to }5\text{ V}$ $R_{\text{SNS}} = 1\text{ k}\Omega$			40	μs
t_{SNSTON2}	Settling time from rising edge of DIA_EN	$V_{\text{ENx}} = 0\text{ V}$, $V_{\text{DIA_EN}} = 0\text{ V to }5\text{ V}$ $R_{\text{SNS}} = 1\text{ k}\Omega$			70	μs
t_{SNSTOFF}	Settling time from falling edge of DIA_EN	$V_{\text{ENx}} = X$, $V_{\text{DIA_EN}} = 5\text{ V to }0\text{ V}$ $R_{\text{SNS}} = 1\text{ k}\Omega$			20	μs
SNS TIMING - MULTIPLEXER						
t_{MUX}	Settling time from temperature sense to current sense	$V_{\text{ENx}} = X$, $V_{\text{DIA_EN}} = 5\text{ V}$ $V_{\text{SEL1}} = 5\text{ V to }0\text{ V}$, $V_{\text{SEL2}} = X$ $R_{\text{SNS}} = 1\text{ k}\Omega$, $R_L \leq 4\ \Omega$			60	μs
	Settling time from current sense on CHx to CHy	$V_{\text{ENx}} = X$, $V_{\text{DIA_EN}} = 5\text{ V}$ $V_{\text{SEL1}} = 0\text{ V}$, $V_{\text{SEL2}} = 0\text{ V to }5\text{ V}$ $R_{\text{SNS}} = 1\text{ k}\Omega$, $I_{\text{OUT1}} = 2\text{ A}$, $I_{\text{OUT2}} = 4\text{ A}$			20	μs
	Settling time from current sense to temperature sense	$V_{\text{ENx}} = X$, $V_{\text{DIA_EN}} = 5\text{ V}$ $V_{\text{SEL1}} = 0\text{ V to }5\text{ V}$, $V_{\text{SEL2}} = X$ $R_{\text{SNS}} = 1\text{ k}\Omega$, $R_L \leq 4\ \Omega$			60	μs

7.7 Switching Characteristics

 $V_{BB} = 13.5\text{ V}$, $T_J = -40^\circ\text{C to }+150^\circ\text{C}$ (unless otherwise noted)

PARAMETER		TEST CONDITIONS	MIN	TYP	MAX	UNIT
t_{DR}	Turnon delay time	$V_{BB} = 13.5\text{ V}$, $R_L \leq 4\ \Omega$, 50% EN rising to 10% V_{OUT} rising	20	60	100	μs
t_{DF}	Turnoff delay time	$V_{BB} = 13.5\text{ V}$, $R_L \leq 4\ \Omega$, 50% EN falling to 90% V_{OUT} Falling	20	60	100	μs
SR_R	V_{OUTx} rising slew rate	$V_{BB} = 13.5\text{ V}$, 20% to 80% of V_{OUT} , $R_L \leq 4\ \Omega$	0.1	0.4	0.7	$\text{V}/\mu\text{s}$
SR_F	V_{OUTx} falling slew rate	$V_{BB} = 13.5\text{ V}$, 80% to 20% of V_{OUT} , $R_L \leq 4\ \Omega$	0.1	0.4	0.7	$\text{V}/\mu\text{s}$
t_{ON}	Turnon time	$V_{BB} = 13.5\text{ V}$, $R_L \leq 4\ \Omega$, 50% EN rising to 80% V_{OUT} rising	39	87	145	μs
t_{OFF}	Turnoff time	$V_{BB} = 13.5\text{ V}$, $R_L \leq 4\ \Omega$, 50% EN rising to 80% V_{OUT} rising	39	87	147	μs
$t_{\text{ON}} - t_{\text{OFF}}$	Turnon and turnoff matching	200- μs enable pulse	-50	0	50	μs
E_{ON}	Switching energy losses during turnon	$V_{BB} = 13.5\text{ V}$, $R_L \leq 4\ \Omega$		0.4		mJ
E_{OFF}	Switching energy losses during turnoff	$V_{BB} = 13.5\text{ V}$, $R_L \leq 4\ \Omega$		0.4		mJ



图 1. Switching Characteristics Definitions



NOTE1: Rise and fall times of control signals are 100 ns. Control signals include: EN1, EN2, DIA_EN, SEL1, SEL2.

NOTE2: SEL1 and SEL2 must be set to the appropriate values.

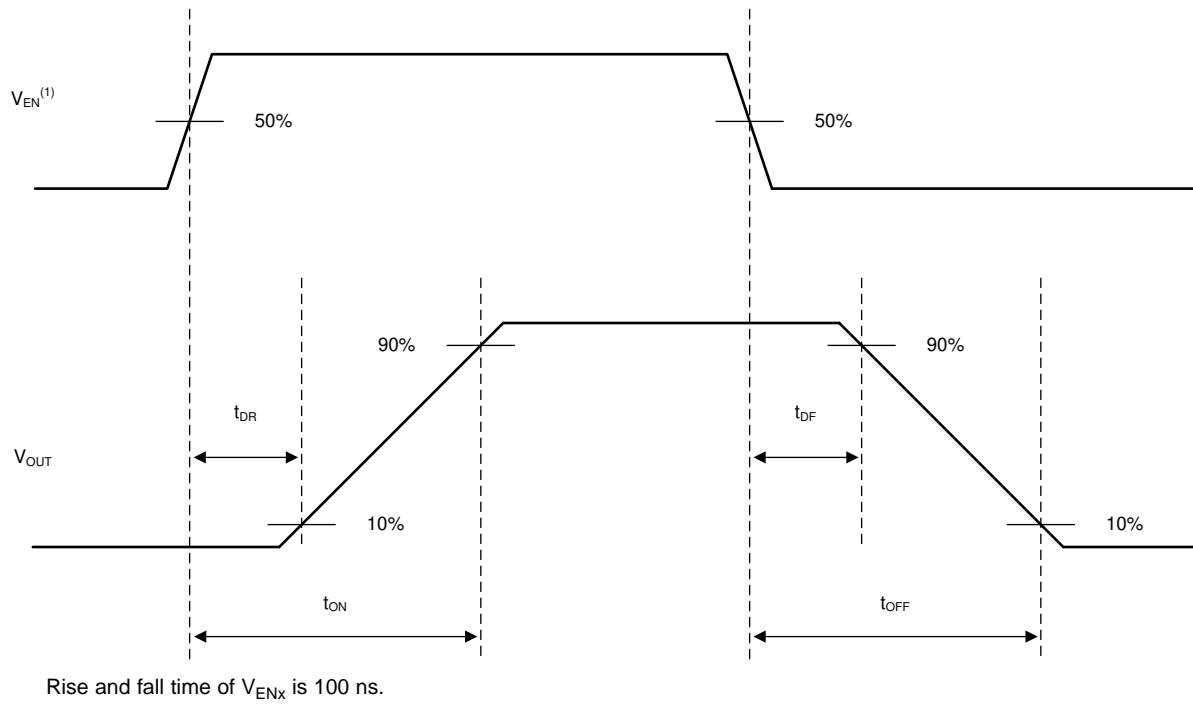
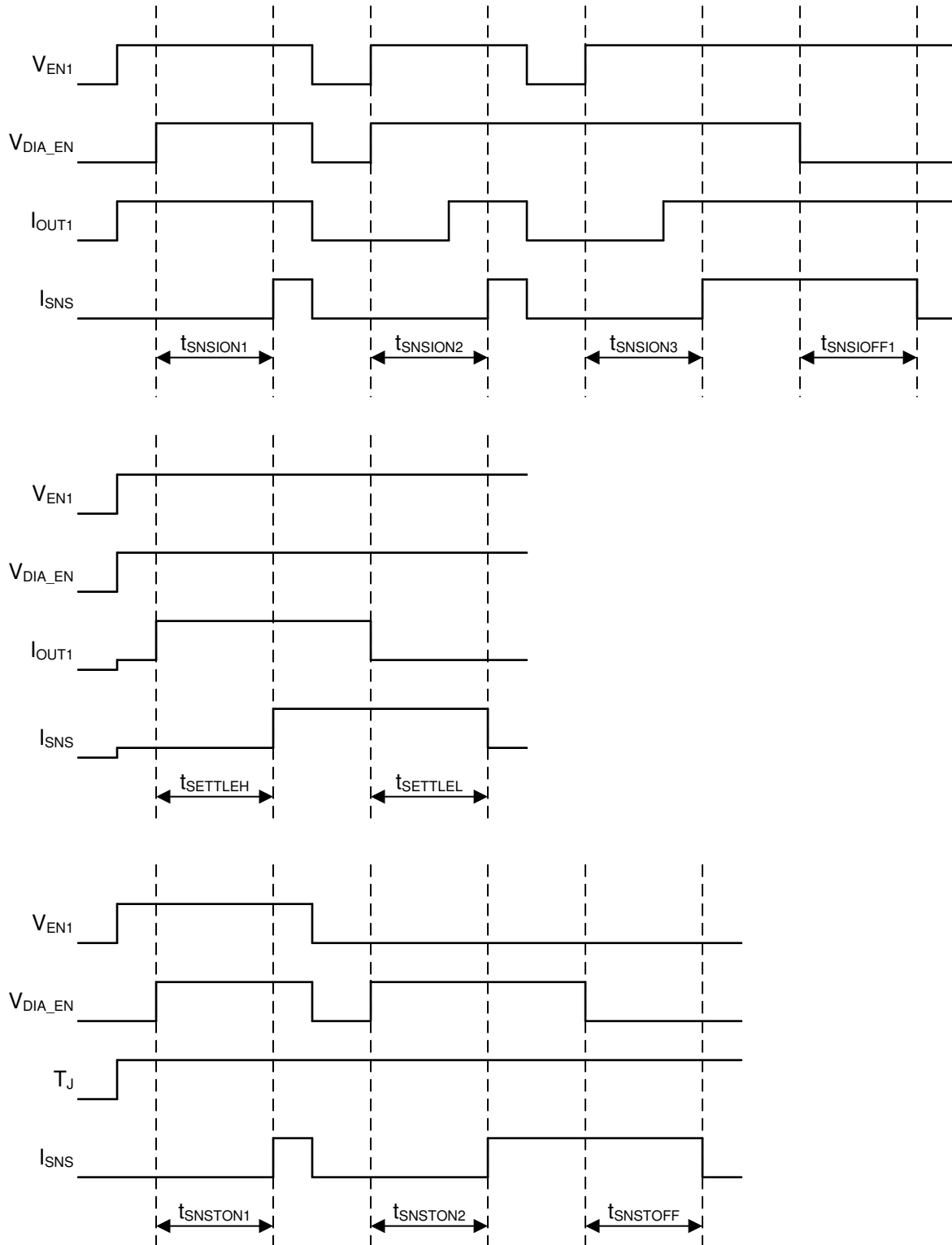
图 2. SNS Timing Characteristics Definitions

7.8 Typical Characteristics



图 3. Transient Thermal Impedance 1 Channel Enabled



图 4. Transient Thermal Impedance Both Channels Enabled

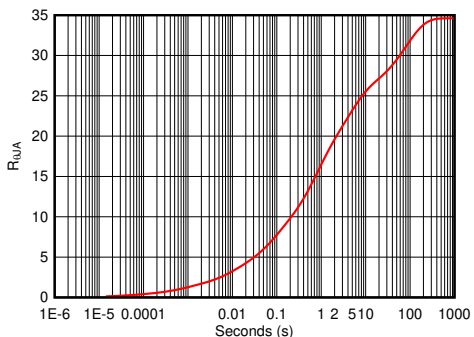

图 5. $R_{\theta JA}$ vs Copper Area

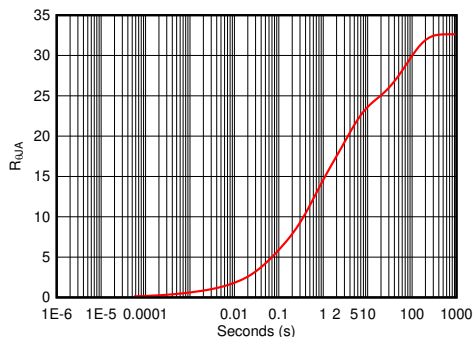

$V_{OUTX} = 0\text{ V}$ $V_{ENX} = 0\text{ V}$ $V_{DIAG_EN} = 0\text{ V}$

图 6. Standby Current (I_{SB}) vs Temperature

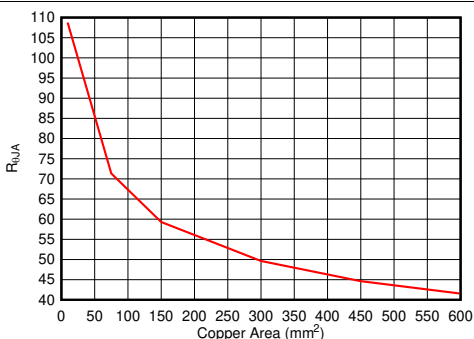
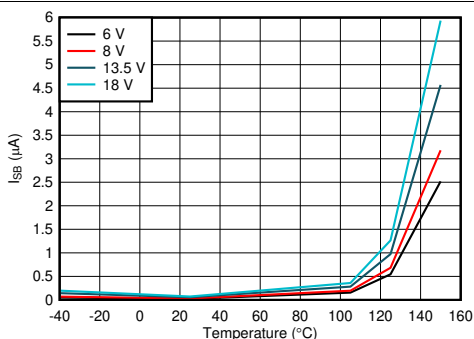
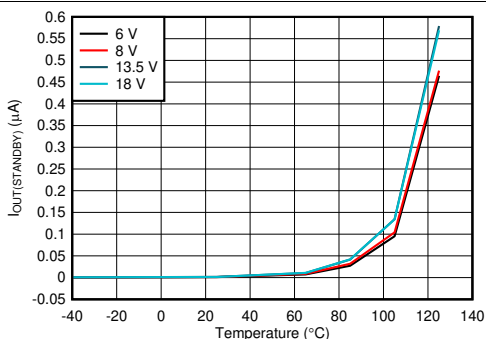

$V_{OUTX} = 0\text{ V}$ $V_{ENX} = 0\text{ V}$ $V_{DIAG_EN} = 0\text{ V}$
Both Channels

图 7. Output Leakage Current ($I_{OUT(standby)}$) vs Temperature

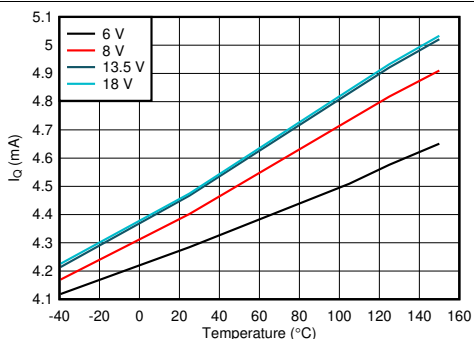

$I_{OUTX} = 0\text{ A}$ $V_{ENX} = 5\text{ V}$ $V_{DIAG_EN} = 5\text{ V}$
 $R_{SNS} = 1\text{ k}\Omega$ $V_{SEL1} = V_{SEL2} = 0\text{ V}$

图 8. Quiescent Current (I_Q) vs Temperature

Typical Characteristics (接下页)

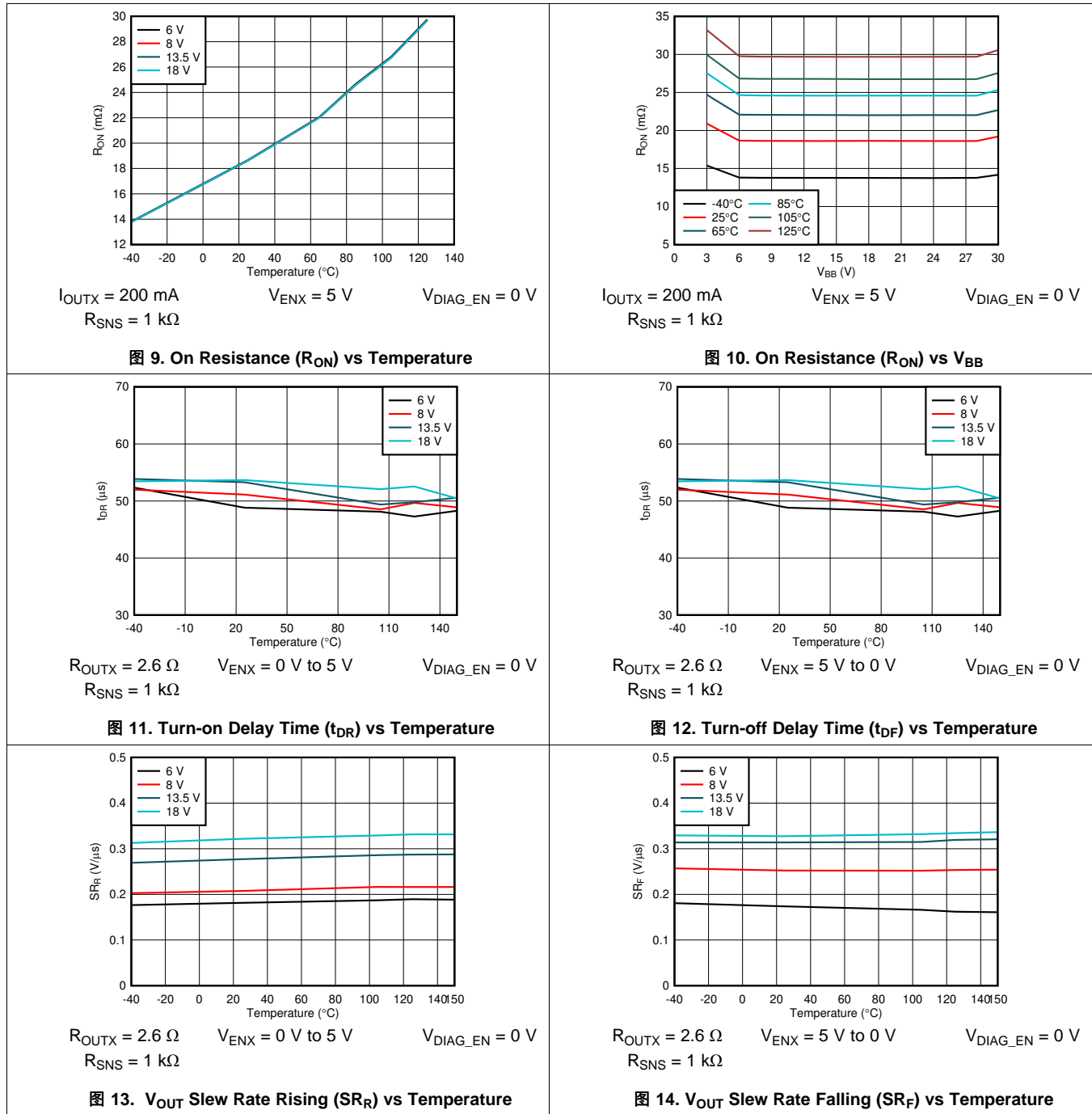

Typical Characteristics (接下页)



图 15. Turn-on Time (t_{ON}) vs Temperature



图 16. Turn-off Time (t_{OFF}) vs Temperature

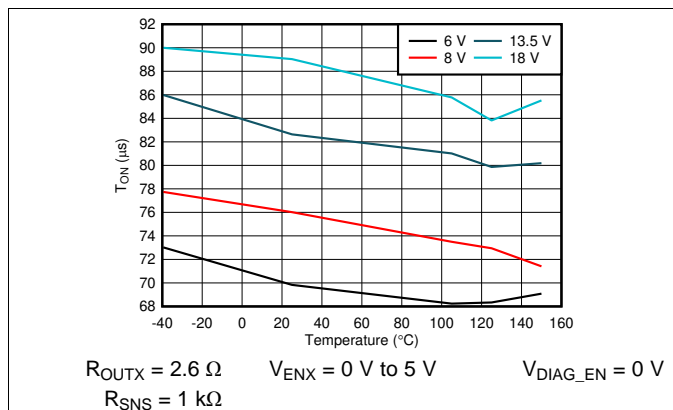

图 17. Current Sense Output Current (I_{SNSI}) vs Load Current (I_{OUT}) Across Temperature

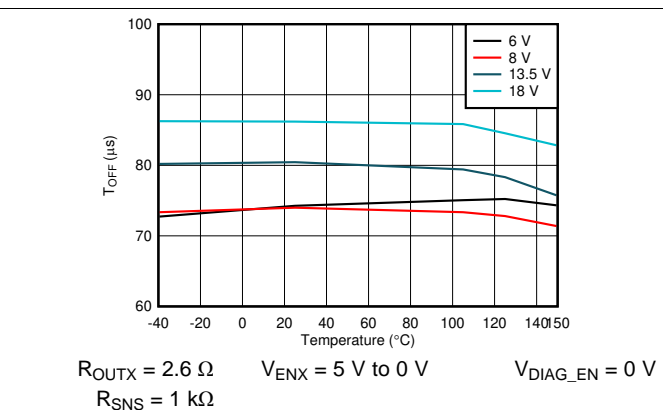

图 18. Current Sense Output Current (I_{SNSI}) vs Load Current (I_{OUT}) Across V_{BB}

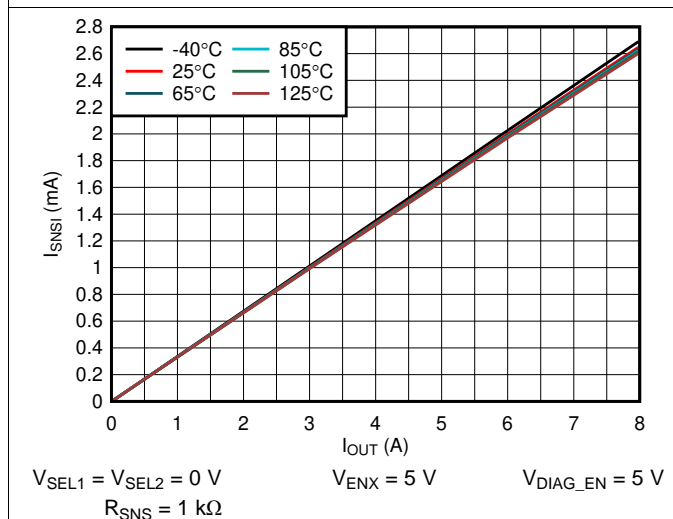

图 19. Temperature Sense Output Current (I_{SNST}) vs Temperature

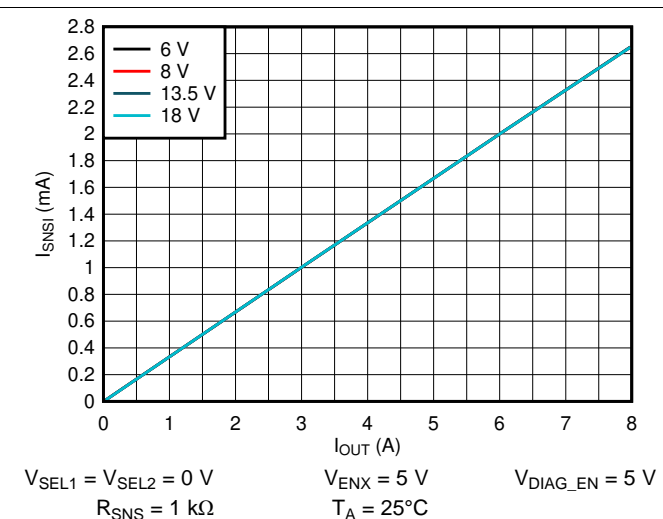

图 20. Fault High Output Current (I_{SNSFH}) vs Temperature

Typical Characteristics (接下页)

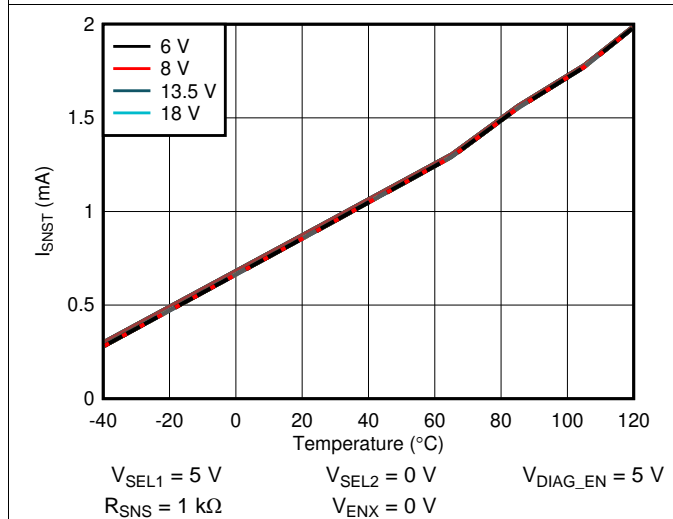

Typical Characteristics (接下页)

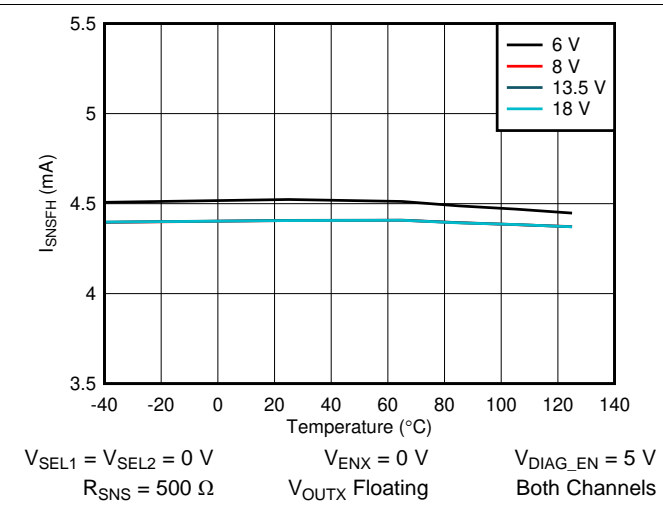
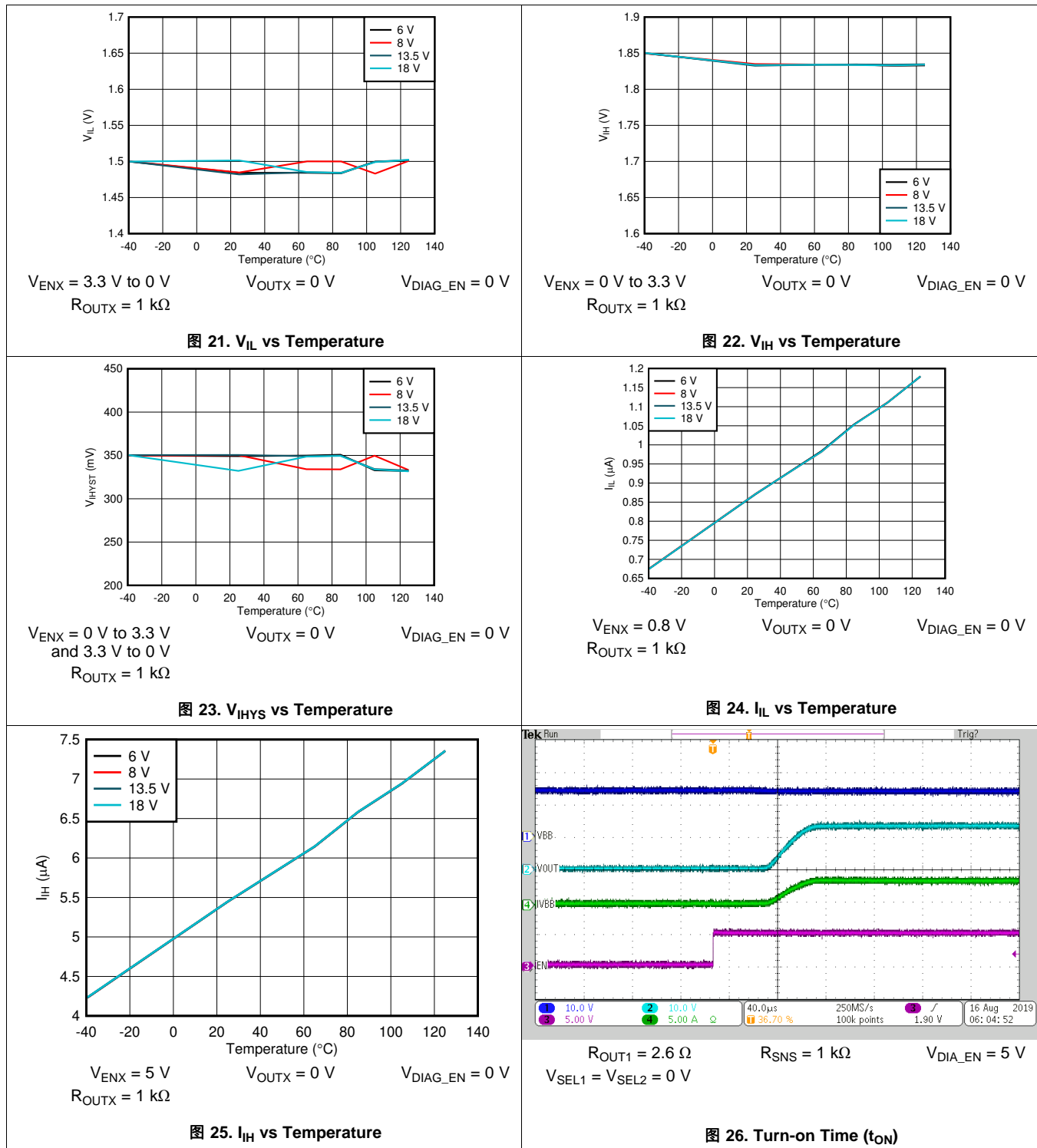
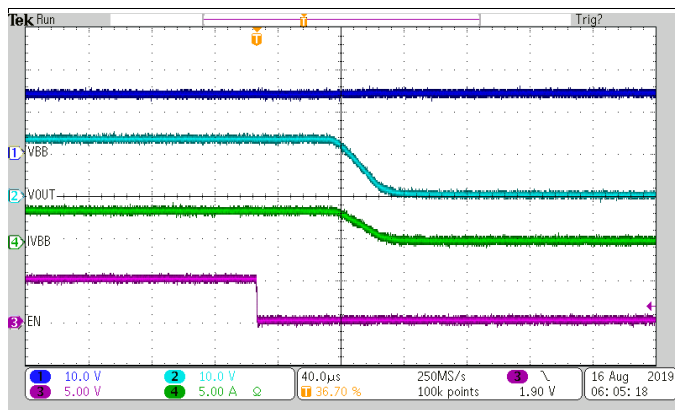

$R_{OUT1} = 2.6 \Omega$ $R_{SNS} = 1 \text{ k}\Omega$ $V_{DIA_EN} = 5 \text{ V}$
 $V_{SEL1} = V_{SEL2} = 0 \text{ V}$

图 27. Turn-off Time (t_{OFF})

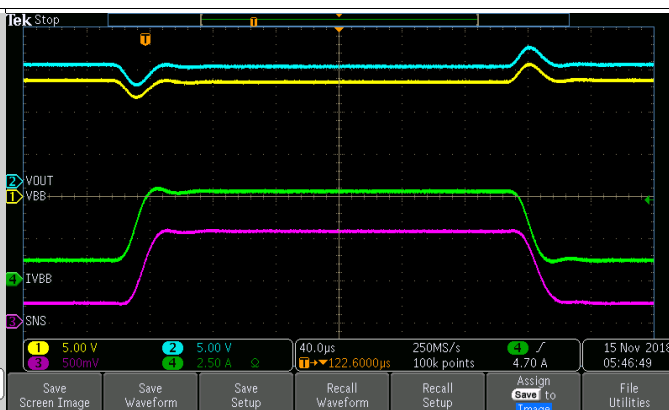

$R_{OUT1} = 2.6 \Omega$ $R_{SNS} = 1 \text{ k}\Omega$ $V_{SEL1} = V_{SEL2} = 0 \text{ V}$
 $I_{OUT1} = 1 \text{ A to } 5 \text{ A}$ $V_{BB} = 13.5 \text{ V}$

图 28. I_{SNS} Settling time ($t_{SNSION1}$) on Load Step

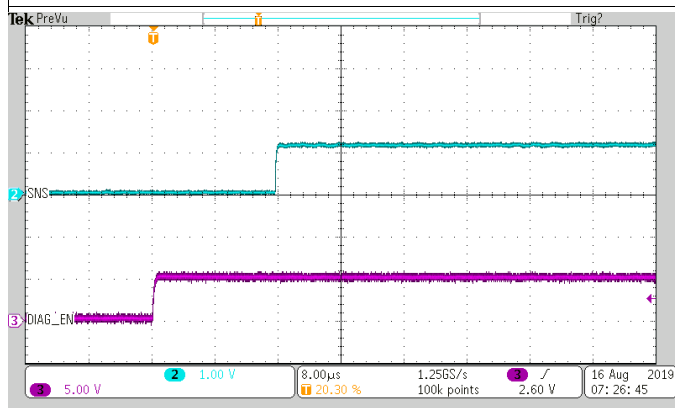

$V_{BB} = 13.5 \text{ V}$ $T_A = 25^\circ\text{C}$ $I_{OUT1} = 5 \text{ A}$
 $V_{EN} = 0 \text{ V to } 5 \text{ V}$

图 29. SNS Output Current Measurement Enable on DIAG_EN PWM

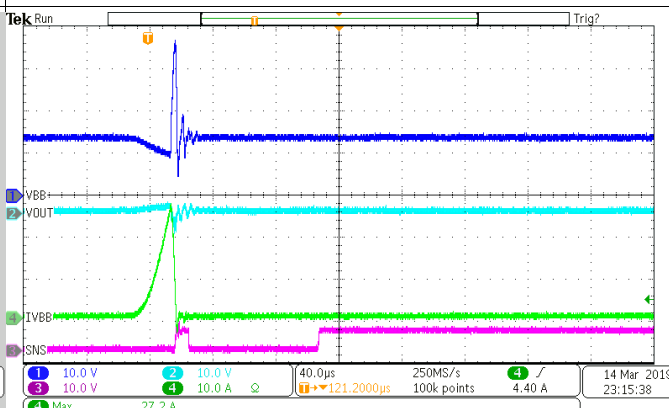

$L_{OUT} = 5 \mu\text{H to GND}$ $R_{LIM} = 5 \text{ k}\Omega$ $V_{SEL1} = V_{SEL2} = 0 \text{ V}$
 $V_{EN} = 0 \text{ V to } 5 \text{ V}$ $V_{DIA_EN} = 5 \text{ V}$ $T_A = 25^\circ\text{C}$

图 30. Device Version A Short Circuit Event

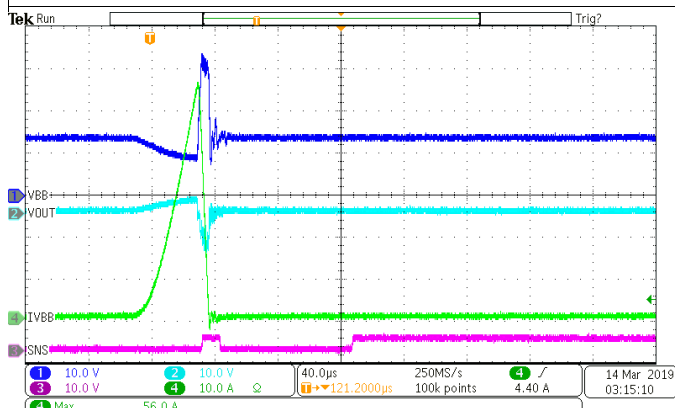

$L_{OUT} = 5 \mu\text{H to GND}$ $R_{LIM} = 5 \text{ k}\Omega$ $V_{SEL1} = V_{SEL2} = 0 \text{ V}$
 $V_{EN} = 0 \text{ V to } 5 \text{ V}$ $V_{DIA_EN} = 5 \text{ V}$ $T_A = 25^\circ\text{C}$

图 31. Device Version B Short Circuit Event

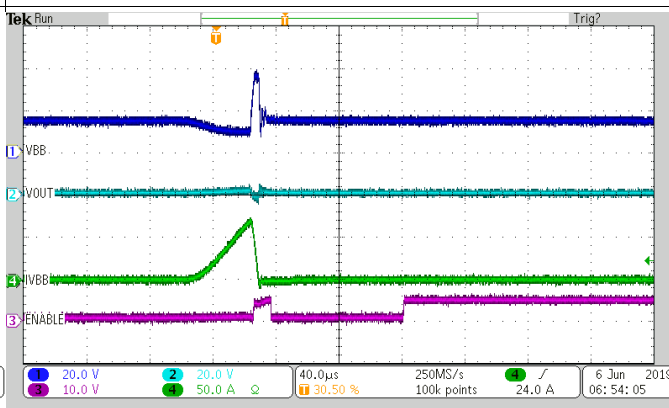

$L_{OUT} = 5 \mu\text{H to GND}$ $R_{LIM} = 5 \text{ k}\Omega$ $V_{SEL1} = V_{SEL2} = 0 \text{ V}$
 $V_{EN} = 0 \text{ V to } 5 \text{ V}$ $V_{DIA_EN} = 5 \text{ V}$ $T_A = 25^\circ\text{C}$

图 32. Device Version F Short Circuit Event

Typical Characteristics (接下页)



图 33. 5 mH Inductive Load Demagnetization

8 Parameter Measurement Information

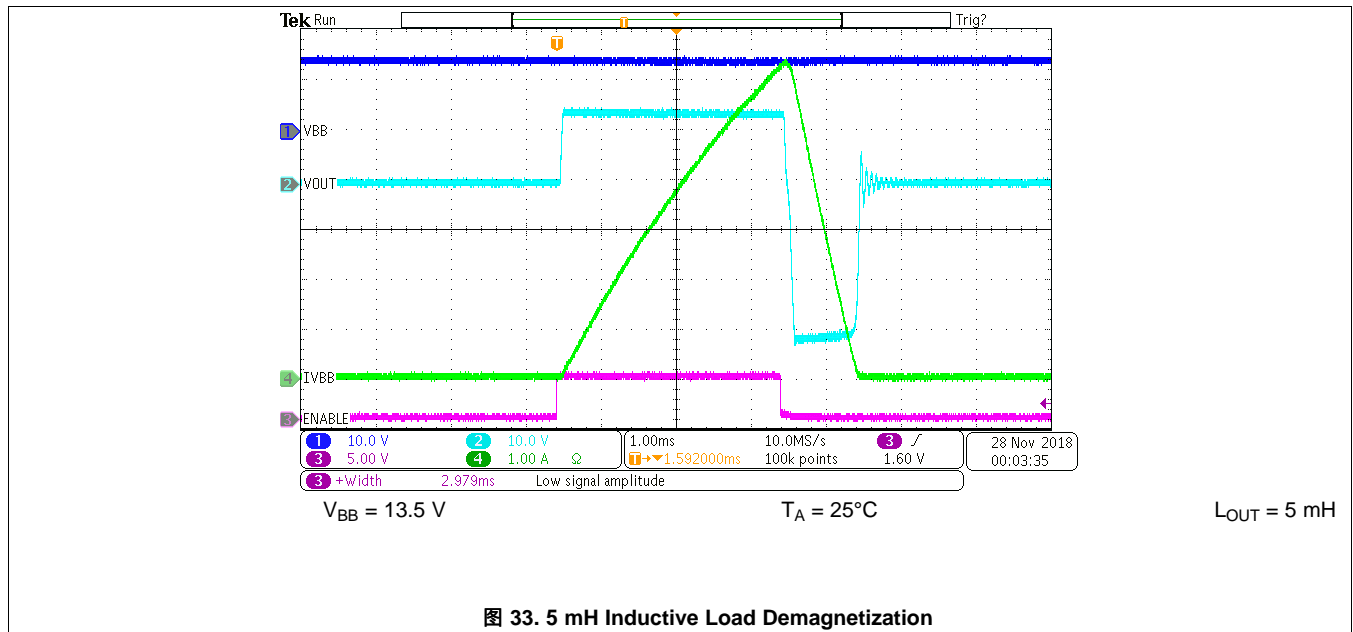

图 34. Parameter Definitions

9 Detailed Description

9.1 Overview

The TPS2HB16-Q1 device is a dual-channel smart high-side switch intended for use with 12-V automotive batteries. Many protection and diagnostic features are integrated in the device.

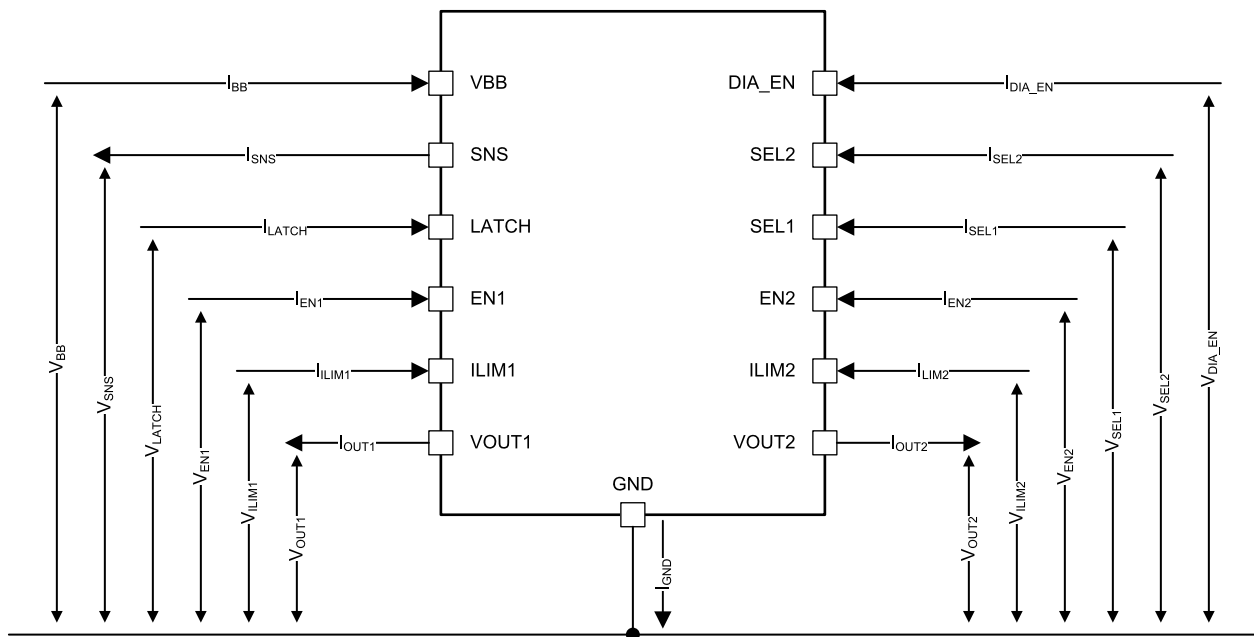
Diagnostics features include the analog SNS output that is capable of providing a signal that is proportional to load current or device temperature. The high-accuracy load current sense allows for diagnostics of complex loads. Version F of the device includes open drain FLT1 and FLT2 pins that indicates device fault states.

This device includes protection through thermal shutdown, current limiting, transient withstand, and reverse battery operation. For more details on the protection features, refer to the [Feature Description](#) and [Application Information](#) sections of the document.

The TPS2HB16-Q1 is one device in a family of TI high side switches. For each device, the part number indicates elements of the device behavior. [图 35](#) gives an example of the device nomenclature.



图 35. Naming Convention

9.2 Functional Block Diagram

The functional block diagram shown is for device versions A/B.

For version F, the ILIM1 and ILIM2 pins will be replaced by open drain outputs $\overline{FLT1}$ and $\overline{FLT2}$.

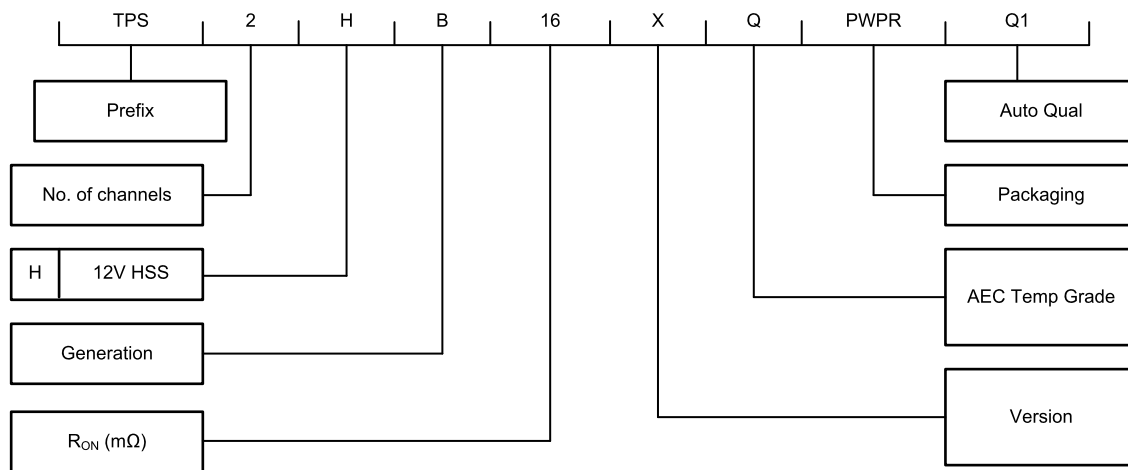
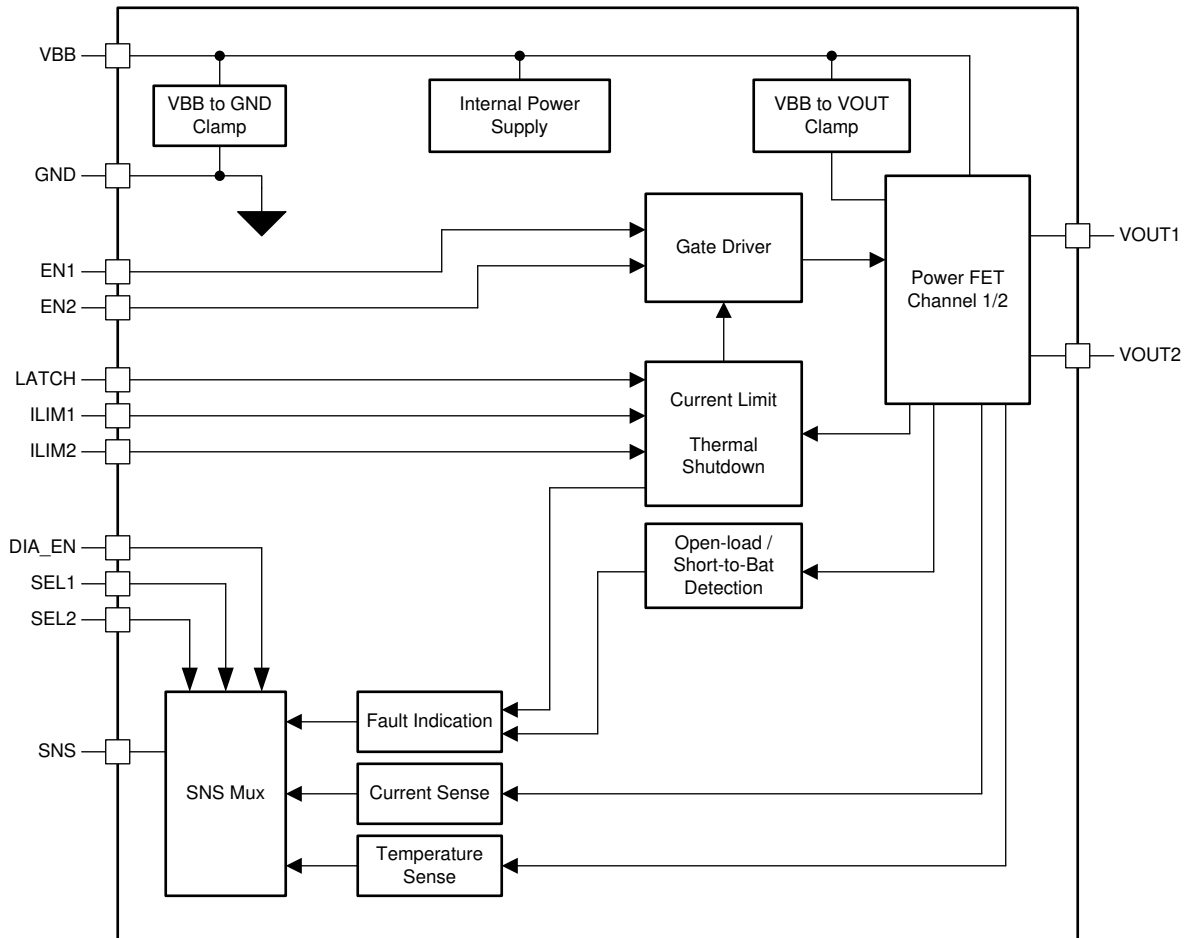

9.3 Feature Description

9.3.1 Protection Mechanisms

The TPS2HB16-Q1 is designed to operate in the automotive environment. The protection mechanisms allow the device to be robust against many system-level events such as load dump, reverse battery, short-to-ground, and more.

There are two protection features which, if triggered, will cause the switch to automatically disable:

- Thermal Shutdown
- Current Limit

When any of these protections are triggered, the device will enter the FAULT state. In the FAULT state, the fault indication will be available on the SNS pin (see the [Diagnostic Mechanisms](#) section of the data sheet for more details). For version F of the device, the fault will also be indicated on the $\overline{\text{FLT1}}$ or $\overline{\text{FLT2}}$ pin, depending on the channel that recognizes the fault.

The switch is no longer held off and the fault indication is reset when all of the below conditions are met:

- LATCH pin is low
- t_{RETRY} has expired
- All faults are cleared (thermal shutdown, current limit)

注

CH1 and CH2 operate independently. If there is a fault on one channel, the other channel is not affected. On version F of the device, $\overline{\text{FLT1}}$ and $\overline{\text{FLT2}}$ each independently diagnose each channel output.

9.3.1.1 Thermal Shutdown

The device includes a temperature sensor on each power FET and also within the controller portion of the device. There are two cases that the device will consider to be a thermal shutdown fault:

- $T_{\text{J,FET}} > T_{\text{ABS}}$
- $(T_{\text{J,FET}} - T_{\text{J,controller}}) > T_{\text{REL}}$

After the fault is detected, the relevant switch will turn off. Each channel is turned off based on the measurement of temperature sensor for that channel. Therefore, if the thermal fault is detected on only one channel, the other channel continues operation. If $T_{\text{J,FET}}$ passes T_{ABS} , the fault is cleared when the switch temperature decreases by the hysteresis value, T_{HYS} . If instead the T_{REL} threshold is exceeded, the fault is cleared after T_{RETRY} passes.

9.3.1.2 Current Limit

When I_{OUT} reaches the current limit threshold, I_{CL} , the channel will switch off immediately. The I_{CL} value will vary with slew rate and a fast current increase that occurs during a powered-on short circuit can temporarily go above the specified I_{CL} value. When the switch is in the FAULT state it will output an output current I_{SNSFH} on the SNS pin and on version F of the device, the fault will also be indicated on the corresponding FLT pin.

During a short circuit event, the device will hit the I_{CL} value that is listed in the [Electrical Characteristics](#) table (for the given device version and R_{ILIM}) and then turn the output off to protect the device. The device will register a short circuit event when the output current exceeds I_{CL} , however the measured maximum current may exceed the I_{CL} value due to the TPS2HB16-Q1 deglitch filter and turn-off time. The device is specified to protect itself during a short circuit event over the nominal supply voltage range (as defined in the [Electrical Characteristics](#) table) at 125°C.

The current limit specification in the datasheet is based on the part being enabled into a short circuit condition with 5- μH inductor on the input and output and the input resistance being less than 10 m Ω and the output impedance less than 100 m Ω . When the part is enabled into this short circuit condition, the current will rise up to the threshold specified in the [Electrical Characteristics](#) table before it begins to shut off the current. The deglitch filter time for the device to react to the current threshold is 3 μs . Therefore if you take Version A/B and subtract 3 μs from the maximum current value, the current limit threshold will align with the value specified in the [Electrical Characteristics](#) table.

Feature Description (接下页)

9.3.1.2.1 Current Limit Foldback

Version B and F of the TPS2HB16-Q1 implement a current limit foldback feature that is designed to protect the device in the case of a long-term fault condition. If the device undergoes fault shutdown events (either of thermal shutdown or current limit) seven consecutive times, the current limit will be reduced to half of the original value. The device will revert back to the original current limit threshold if either of the following occurs:

- The device goes to standby mode.
- The switch turns on and turns off without any fault occurring.

Version A does not implement the current limit foldback due to the lower current limit causing less harm during repetitive long-term faults.

9.3.1.2.2 Programmable Current Limit

The TPS2HB16-Q1 includes an adjustable current limit. Some applications (for example, incandescent bulbs) will require a high current limit. Other applications can benefit from a lower current limit threshold. In general, wherever possible a lower current limit is recommended due to allowing system advantages through:

- Reduced size and cost in current carrying components such as PCB traces and module connectors
- Less disturbance at the power supply (V_{BB} pin) during a short circuit event
- Improved protection of the downstream load

To set the current limit threshold, connect a resistor from I_{LIM} to V_{BB} . The current limit threshold is determined by [Equation 1](#) (R_{ILIM} in $k\Omega$):

$$I_{CL} = K_{CL} / R_{ILIM} \quad (1)$$

The R_{ILIM} range is between 5 $k\Omega$ and 25 $k\Omega$. An R_{ILIM} resistor is required; however, in the fault case where the pin is floating, grounded, or outside of this range the current limit will default to an internal level that is defined in the [Specifications](#) section of this document.

注

Capacitance on the I_{LIM} pin can cause I_{LIM} to go out of range during short circuit events. For accurate current limiting, place R_{ILIM} near to the device with short traces to ensure <5 pF capacitance to GND on the I_{LIM} pin.

For device version F, there is no I_{LIMX} pin and the current limit is not adjustable. In this case, the device will current limit at the internal threshold I_{CL} as defined in the [Electrical Characteristics](#) section.

9.3.1.2.3 Undervoltage Lockout (UVLO)

The device monitors the supply voltage V_{BB} to prevent unpredicted behaviors in the event that the supply voltage is too low. When the supply voltage falls down to V_{UVLOF} , the output stage is shut down automatically. When the supply rises up to V_{UVLOR} , the device turns back on.

During an initial ramp of V_{BB} from 0 V at a ramp rate slower than 1 V/ms, V_{EN} pin will have to be V_{BB} held low until V_{BB} is above UVLO threshold (with respect to board ground) and the supply voltage to the device has reliably reached above the UVLO condition. For best operation, ensure that V_{BB} has risen above UVLO before setting the V_{EN} pin to high.

9.3.1.2.4 V_{BB} During Short-to-Ground

When V_{OUT} is shorted to ground, the module power supply (V_{BB}) can have a transient decrease. This is caused by the sudden increase in current flowing through the wiring harness cables. To achieve ideal system behavior, it is recommended that the module maintain $V_{BB} > 3$ V (above the maximum V_{UVLOF}) during V_{OUT} short-to-ground. This is typically accomplished by placing bulk capacitance on the power supply node.

9.3.1.3 Voltage Transients

The TPS2HB16-Q1 device describes two types of voltage clamps which protect the FET against system-level voltage transients. The two different clamps are shown in [图 36](#).

Feature Description (接下页)

The clamp from V_{BB} to GND is primarily used to protect the controller from positive transients on the supply line (for example, ISO7637-2). The clamp from V_{BB} to V_{OUT} is primarily used to limit the voltage across the FET when switching off an inductive load. If the voltage potential from V_{BB} to GND exceeds the V_{BB} clamp level, the clamp will allow current to flow through the device from V_{BB} to GND (Path 2). If the voltage potential from V_{BB} to V_{OUT} exceeds the clamping voltage, the power FET will allow current to flow from V_{BB} to V_{OUT} (Path 3). Additional capacitance from V_{BB} to GND can increase the reliability of the system during ISO 7637 pulse 2-A testing.



图 36. Current Path During Supply Voltage Transient

9.3.1.3.1 Load Dump

The TPS2HB16-Q1 device is tested according to ISO 16750-2:2010(E) suppressed load dump pulse. The device supports up to 40-V load dump transient and will maintain normal operation during the load dump pulse. If the switch is enabled, it will stay enabled and if the switch is disabled, it will stay disabled.

9.3.1.4 Driving Inductive Loads

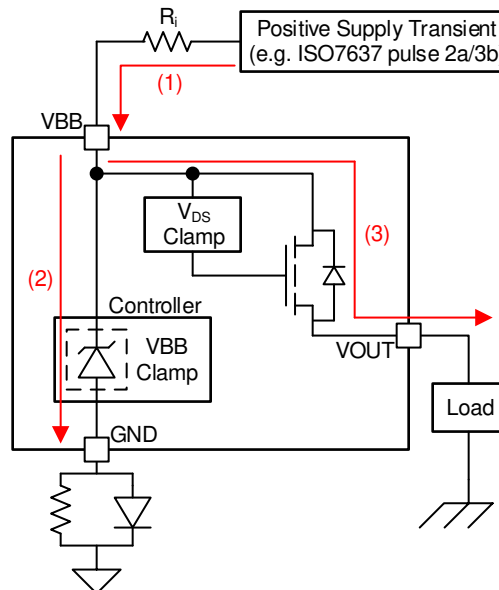
When switching off an inductive load, the inductor may impose a negative voltage on the output of the switch. The TPS2HB16-Q1 includes a voltage clamp to limit voltage across the FET. The maximum acceptable load inductance is a function of the device robustness.

For more information on driving inductive loads, refer to TI's [How To Drive Inductive, Capacitive, and Lighting Loads with Smart High Side Switches](#) application report.

9.3.1.5 Reverse Battery

In the reverse battery condition, the switch will automatically be enabled regardless of the state of EN1/EN2 to prevent excess power dissipation inside the MOSFET body diode. In many applications (for example, resistive loads), the full load current may be present during reverse battery. In order to activate the automatic switch on feature, the SEL2 pin must have a path to module ground. This may be path 1 as shown in [图 37](#), or if the SEL2 pin is unused, the path may be through R_{PROT} to module ground.

Protection features like thermal shutdown are not available during a reverse battery event. Care must be taken to ensure that excessive power is not dissipated in the switch during the reverse battery condition.

There are two options for blocking reverse current in the system. The first option is to place a blocking device (FET or diode) in series with the battery supply, blocking all current paths. The second option is to place a blocking diode in series with the GND node of the high-side switch. This method will protect the controller portion of the switch (path 2), but it will not prevent current from flowing through the load (path 3). The diode used for the second option may be shared amongst multiple high-side switches.

Feature Description (接下页)

Path 1 shown in 图 37 is blocked inside of the device.



图 37. Current Path During Reverse Battery

9.3.1.6 Fault Event – Timing Diagrams (Version A/B)

注

All timing diagrams assume that the SELx pins are set to select the relevant channel.

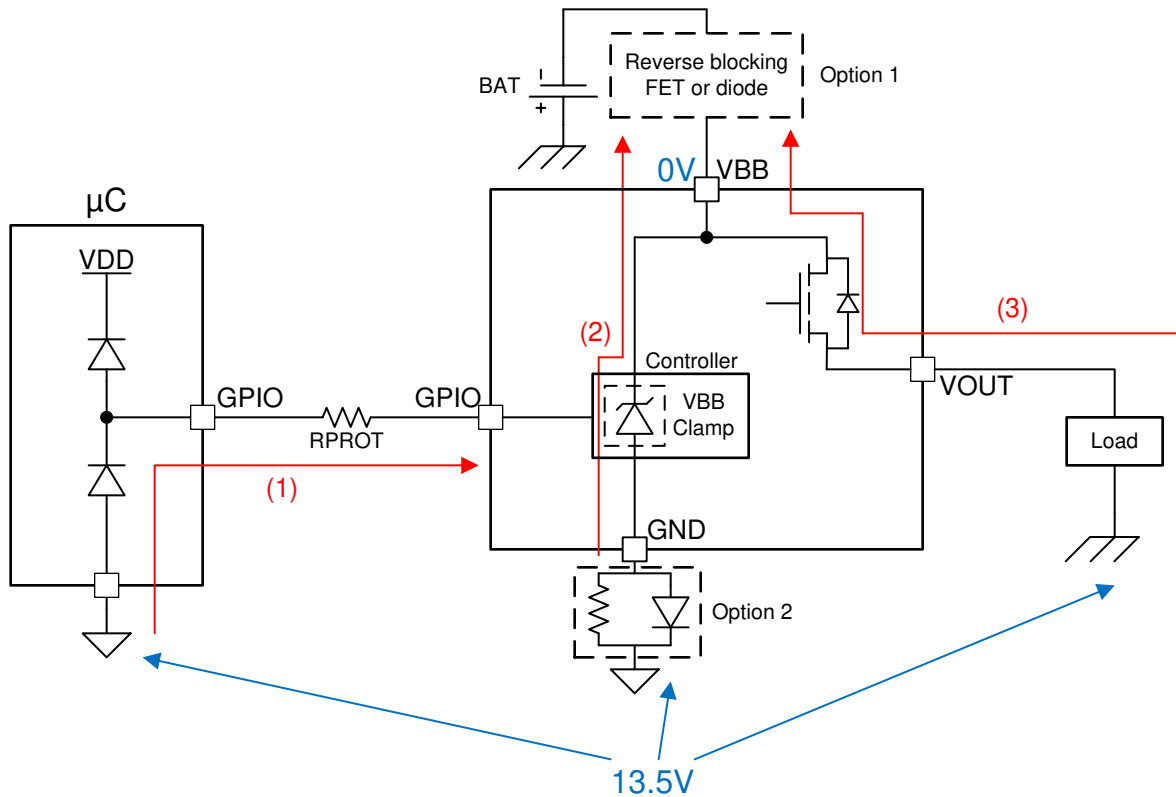
The LATCH, DIA_EN, and ENx pins are controlled by the user. The timing diagrams represent a possible use-case.

图 38 shows the immediate current limit switch off and the retry behavior of versions A and B of the device. As shown, the switch will remain latched off until the LATCH pin is low.

Feature Description (接下页)



图 38. Current Limit – Version A and B - Latched Behavior

图 39 shows the immediate current limit switch off behavior of versions A and B. In this example, LATCH is tied to GND; hence, the switch will retry after the fault is cleared and t_{RETRY} has expired.

Feature Description (接下页)

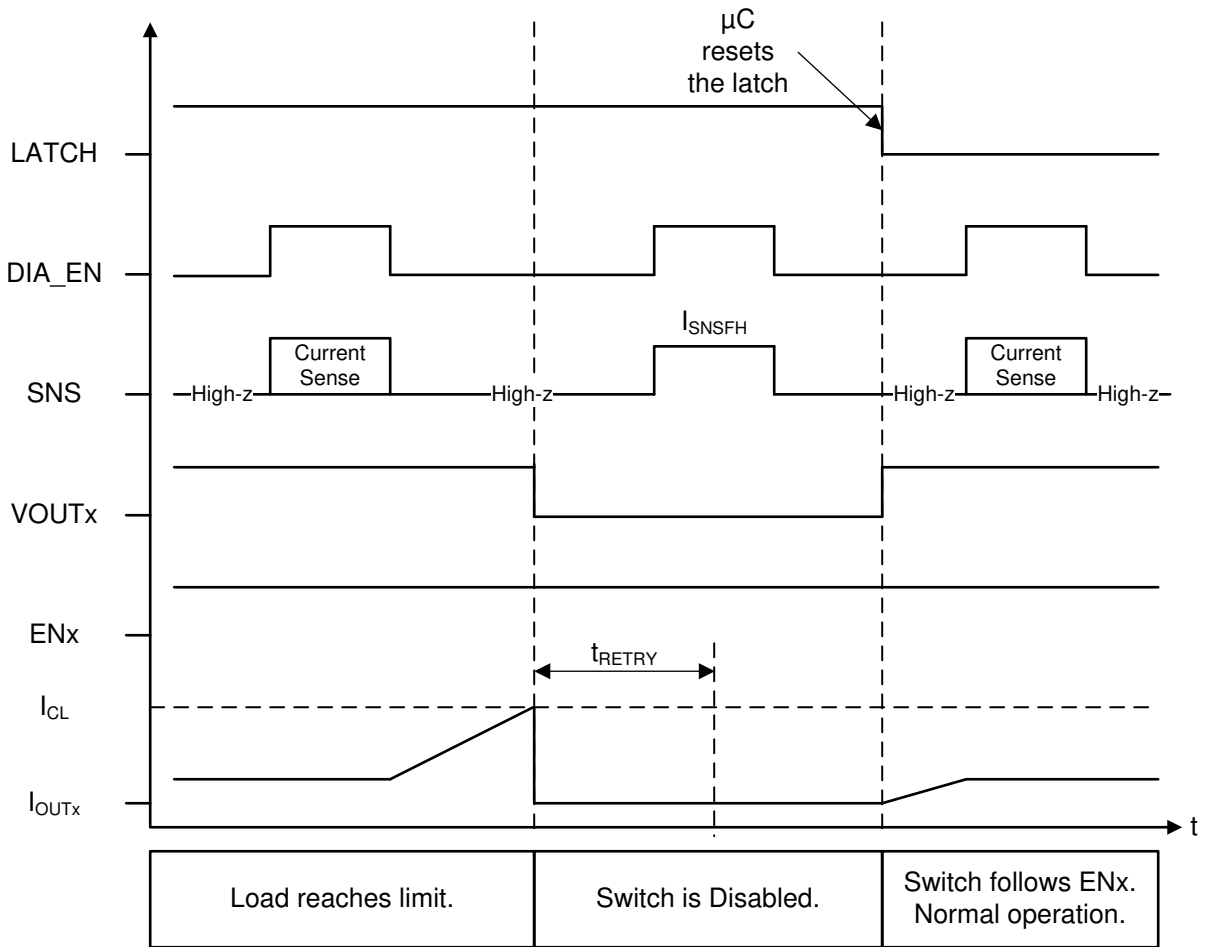

图 39. Current Limit – Version A and B - LATCH = 0

图 40 illustrates auto-retry behavior and provides a zoomed-in view of the fault indication during retry. When the switch retries after a shutdown event, the SNS fault indication will remain at the fault state until V_{OUT} has risen to $V_{BB} - 1.8\text{ V}$. Once V_{OUT} has risen, the SNS fault indication is reset and current sensing is available. If there is a short-to-ground and V_{OUT} cannot rise, the SNS fault indication will remain indefinitely.

注

图 40 assumes that t_{RETRY} has expired by the time that T_J reaches the hysteresis threshold.

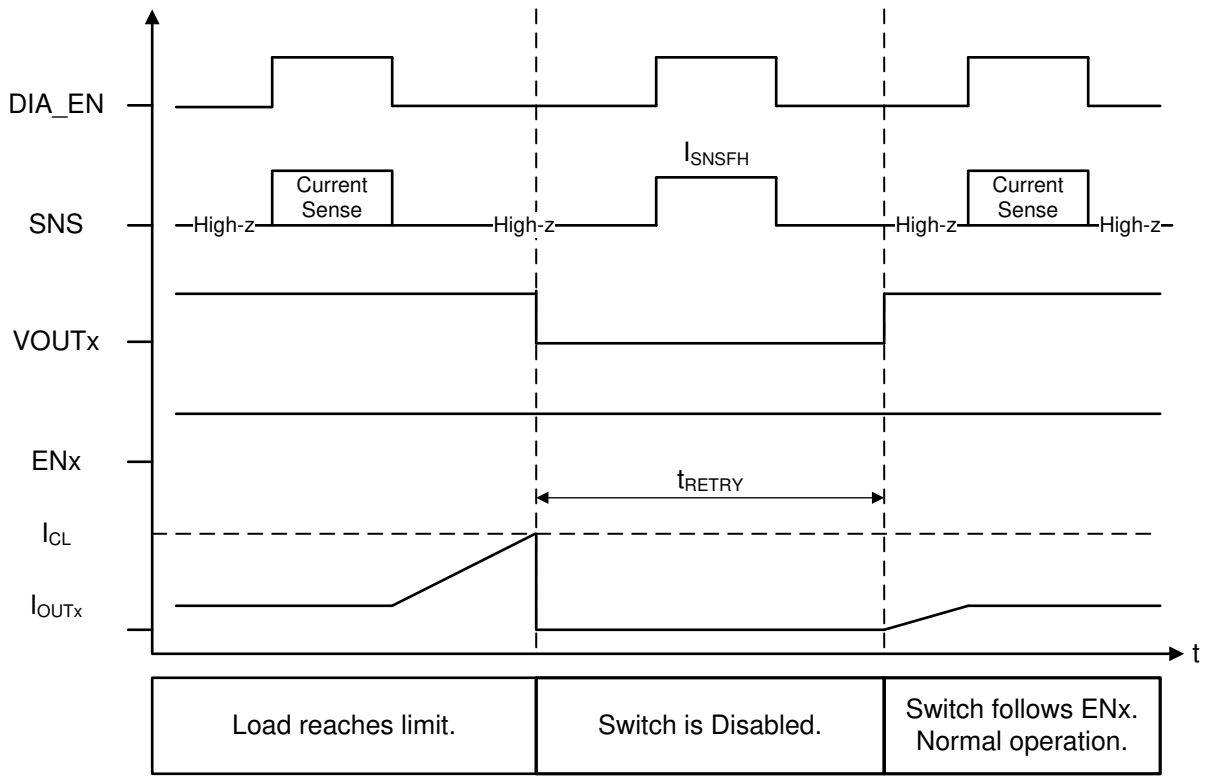
$$LATCH = 0\text{ V and DIA_EN} = 5\text{ V}$$

Feature Description (接下页)



图 40. Fault Indication During Retry

9.3.2 Fault Event – Timing Diagrams - Version F

TPS2HB16-Q1 device version F will follow the same timing and fault diagrams as described for versions A and B, with the only difference being the behavior of the $\overline{FLT1}$ and $\overline{FLT2}$ pins. For each diagram, the $\overline{FLT1}$ or $\overline{FLT2}$ pins will indicate over-current or over-temperature faults for the respective channel. The two pins are independent and will not indicate a fault that corresponds to the opposite channel.

9.3.3 Diagnostic Mechanisms

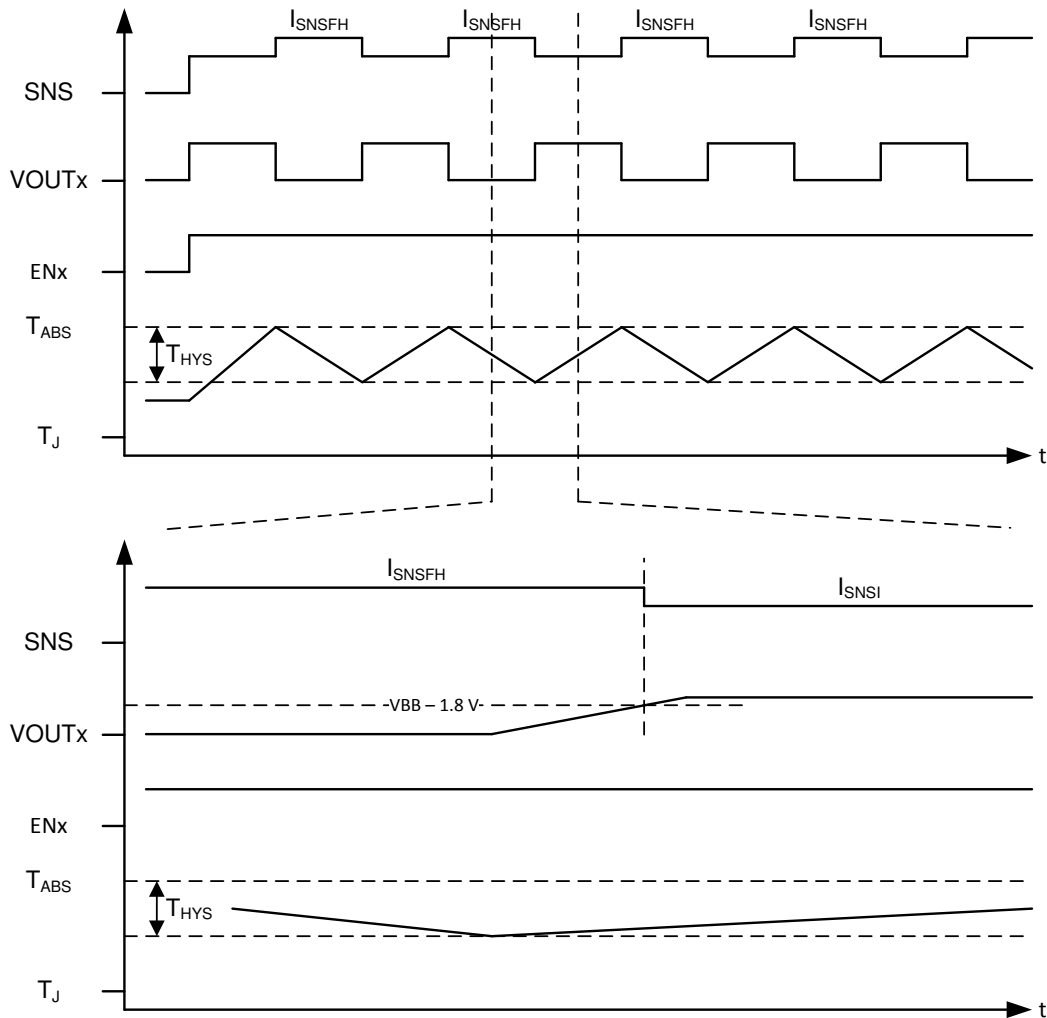
9.3.3.1 $VOUTx$ Short-to-Battery and Open-Load

The TPS2HB16-Q1 is capable of detecting short-to-battery and open-load events regardless of whether the switch is turned on or off, however the two conditions use different methods.

9.3.3.1.1 Detection With Switch Enabled

When the switch is enabled, the $VOUTx$ short-to-battery and open-load conditions can be detected by the current sense feature. In both cases, the load current will be measured through the SNS pin as below the expected value.

Feature Description (接下页)

9.3.3.1.2 Detection With Switch Disabled

While the switch is disabled, if DIA_EN is high, an internal comparator will detect the condition of V_{OUT} . If the load is disconnected (open load condition) or there is a short to battery the V_{OUT} voltage will be higher than the open load threshold ($V_{OL,off}$) and a fault is indicated on the SNS pin and the FLT1 or FLT2 pin on version F. An internal pull-up of $1\text{ M}\Omega$ is in series with an internal MOSFET switch, so no external component is required if only a completely open load must be detected. However, if there is significant leakage or other current draw even when the load is disconnected, a lower value pull-up resistor and switch can be added externally to set the V_{OUT} voltage above the $V_{OL,off}$ during open load conditions.

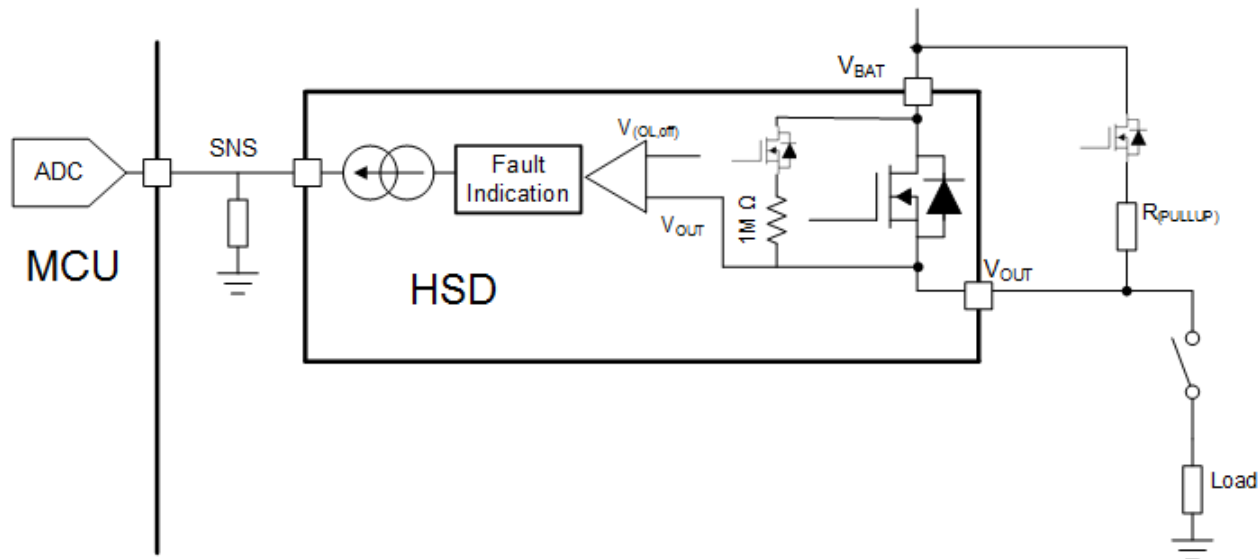

This figure assumes that the device ground and the load ground are at the same potential. In a real system, there may be a ground shift voltage of 1 V to 2 V.

图 41. Short to Battery and Open Load Detection

The detection circuitry is only enabled when DIA_EN = HIGH and EN = LOW. If $V_{OUT} > V_{OL}$, the SNS pin will go to the fault level, but if $V_{OUT} < V_{OL}$ there will be no fault indication. The fault indication will only occur if the SEL2 pin is set to diagnose the respective channel.

While the switch is disabled and DIA_EN is high, the fault indication mechanisms will continuously represent the present status. For example, if V_{OUT} decreases from greater than V_{OL} to less than V_{OL} , the fault indication is reset. Additionally, the fault indication is reset upon the falling edge of DIA_EN or the rising edge of EN.

Feature Description (接下页)



图 42. Open Load

9.3.3.2 SNS Output

The SNS output may be used to sense the load current or device temperature. The SELx pins will select the desired sense signal. The sense circuit will provide a current that is proportional to the selected parameter. This current will be sourced into an external resistor to create a voltage that is proportional to the selected parameter. This voltage may be measured by an ADC or comparator.

To ensure accurate sensing measurement, the sensing resistor should be connected to the same ground potential as the μ C ADC.

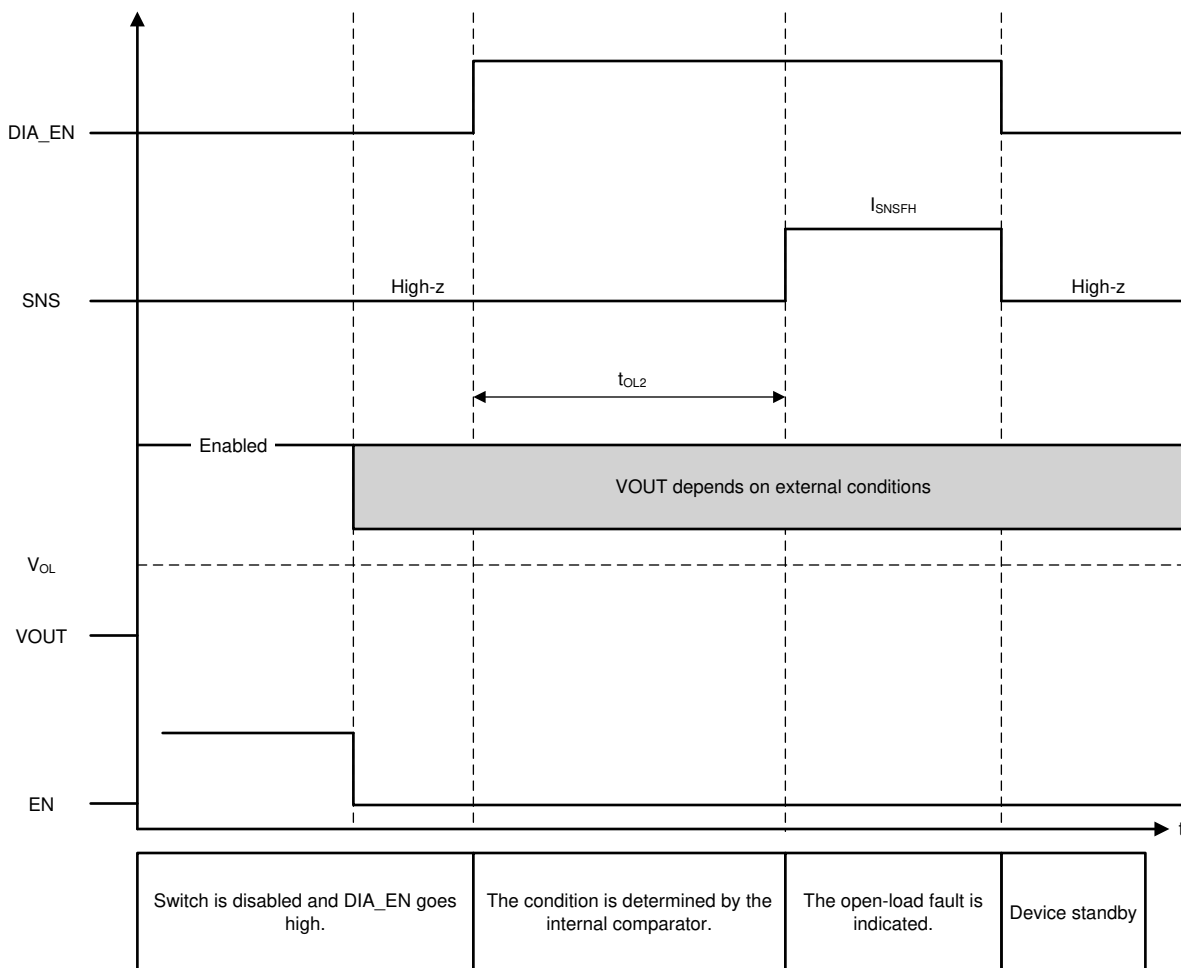
表 3. Analog Sense Transfer Function

PARAMETER	TRANSFER FUNCTION
Load current	$I_{SNSI} = I_{OUT} / K_{SNS}$ (3000)
Device temperature	$I_{SNST} = (T_J - 25^\circ\text{C}) \times dI_{SNST} / dT + 0.85$

The SNS output will also be used to indicate system faults. I_{SNS} will go to the predefined level, I_{SNSFH} , when there is a fault. I_{SNSFH} , dI_{SNS}/dT , and K_{SNS} are defined in the [Specifications](#) section.

In device version F, device temperature measurement is not available so load current measurement is the only sense output.

9.3.3.2.1 R_{SNS} Value

The following factors should be considered when selecting the R_{SNS} value:

- Current sense ratio (K_{SNS})
- Largest and smallest diagnosable load current required for application operation
- Full-scale voltage of the ADC
- Resolution of the ADC

For an example of selecting R_{SNS} value, reference [Selecting the \$R_{SNS}\$ Value](#) in the applications section of this datasheet.

9.3.3.2.1.1 High Accuracy Load Current Sense

In many automotive modules, it is required that the high-side switch provide diagnostic information about the downstream load. With more complex loads, high accuracy sensing is required. A few examples follow:

- **LED lighting:** In many architectures, the body control module (BCM) must be compatible with both incandescent bulbs and also LED modules. The bulb may be relatively simple to diagnose. However, the LED module will consume less current and also can include multiple LED strings in parallel. The same BCM is used in both cases, so the high-side switch can accurately diagnose both load types.
- **Solenoid protection:** Often solenoids are precisely controlled by low-side switches. However, in a fault event, the low-side switch cannot disconnect the solenoid from the power supply. A high-side switch can be used to continuously monitor several solenoids. If the system current becomes higher than expected, the high-side switch can disable the module.

9.3.3.2.1.2 SNS Output Filter

To achieve the most accurate current sense value, it is recommended to filter the SNS output. There are two methods of filtering:

- Low-Pass RC filter between the SNS pin and the ADC input. This filter is illustrated in [Figure 46](#) with typical values for the resistor and capacitor. The designer should select a C_{SNS} capacitor value based on system requirements. A larger value will provide improved filtering but a smaller value will allow for faster transient response.
- The ADC and microcontroller can also be used for filtering. It is recommended that the ADC collects several measurements of the SNS output. The median value of this data set should be considered as the most accurate result. By performing this median calculation, the microcontroller can filter out any noise or outlier data.

9.3.3.3 Fault Indication and SNS Mux

The following faults will be communicated through the SNS output:

- Switch shutdown, due to:
 - Thermal Shutdown
 - Current limit
- Open-Load / V_{OUT} shorted-to-battery

Open-load and short-to-battery are not indicated while the switch is enabled, although these conditions can still be detected through the sense current. Hence, if there is a fault indication corresponding to an enabled channel, then it must be either due to an overcurrent or overtemperature event.

The SNS pin will only indicate the fault if the SELx pins are selecting the relevant channel. When the device is set to measure temperature, the pin will be measuring the temperature of whichever channel is at a higher temperature.

表 4. Version A/B SNS Mux

INPUTS				OUTPUTS
DIA_EN	SEL1	SEL2	FAULT DETECT ⁽¹⁾	SNS
0	X	X	X	High-Z
1	0	0	0	CH1 current
1	0	1	0	CH2 current
1	1	0	0	Device temperature
1	1	1	0	N/A
1	0	0	1	I _{SNSFH}
1	0	1	1	I _{SNSFH}
1	1	0	1	Device temperature
1	1	1	1	N/A

- (1) Fault Detect encompasses multiple conditions:
(a) Switch shutdown and waiting for retry
(b) Open-load and short-to-battery

Version F of the device has a different fault table due to the lack of SEL1 pin functionality and the addition of the FLT1 and FLT2 pins. In all cases, SEL1 should be tied to ground for device version F. The table below shows the FLT mux for Version F of the device. The FLT1 and a FLT2 pin which will each trigger independently. If the fault detect flag corresponds to channel 1 over-current, over-temperature, or open load, FLT1 will trigger, while if the fault detect flag corresponds to channel 2 over-current, over-temperature, or open load, FLT2 will trigger.

表 5. Version F SNS Mux

INPUTS				OUTPUTS
DIA_EN	SEL2	FAULT DETECT ⁽¹⁾	FLT _x	SNS
0	X	X	High-Z	High-Z
1	0	0	High-Z	CH1 current
1	1	0	High-Z	CH2 current
1	0	1	Open-Drain	I _{SNSFH}
1	1	1	Open-Drain	I _{SNSFH}

- (1) Fault Detect encompasses multiple conditions:
(a) Switch shutdown and waiting for retry
(b) Open Load / Short To Battery

9.3.3.4 Resistor Sharing

Multiple high-side channels may use the same SNS resistor as shown in 图 43. This reduces the total number of passive components in the system and the number of ADC terminals that are required of the microcontroller.



图 43. Sharing R_{SNS} Among Multiple Devices

9.3.3.5 High-Frequency, Low Duty-Cycle Current Sensing

Some applications will operate with a high-frequency, low duty-cycle PWM or require fast settling of the SNS output. For example, a 250 Hz, 5% duty cycle PWM will have an on-time of only 200 μ s that must be accommodated. The micro-controller ADC may sample the SNS signal after the defined settling time $t_{SNSION3}$.

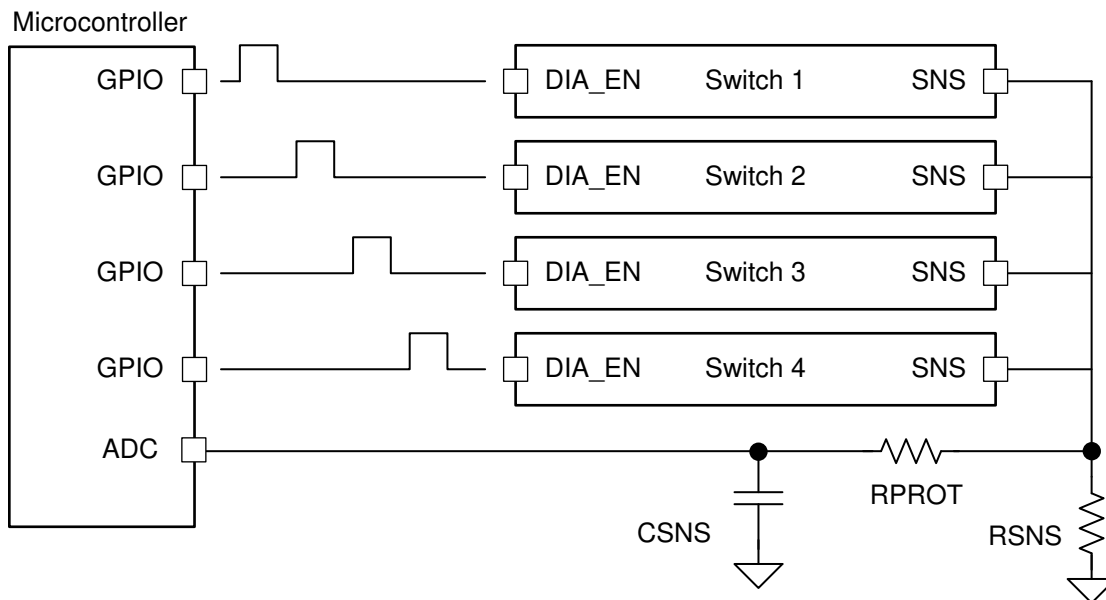

图 44. Current Sensing in Low-Duty Cycle Applications

9.4 Device Functional Modes

During typical operation, the TPS2HB16-Q1 can operate in a number of states that are described below and shown as a state diagram in [Figure 45](#).

9.4.1 Off

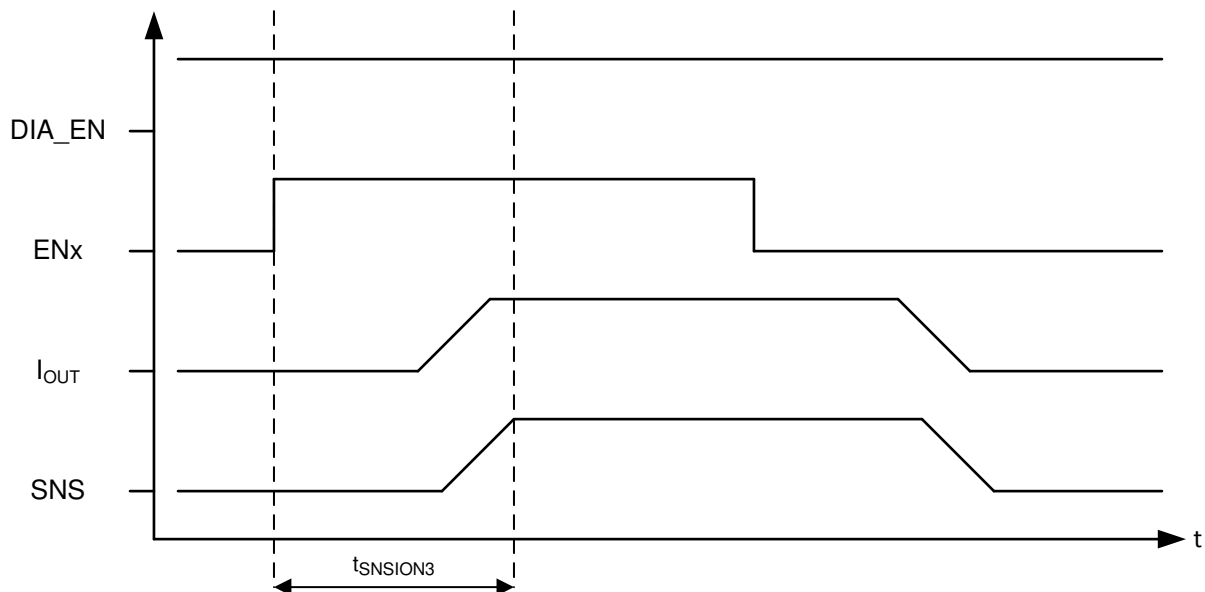
Off state occurs when the device is not powered.

9.4.2 Standby

Standby state is a low-power mode used to reduce power consumption to the lowest level. Diagnostic capabilities are not available in Standby mode.

9.4.3 Diagnostic

Diagnostic state may be used to perform diagnostics while the switches are disabled.

9.4.4 Standby Delay

The Standby Delay state is entered when EN1, EN2, and DIA_EN are low. After t_{STBY} , if the ENx and DIA_EN pins are still low, the device will go to Standby state.

9.4.5 Active

In Active state, one or more of the switches are enabled. The diagnostic functions may be turned on or off during Active state.

9.4.6 Fault

The Fault state is entered if a fault shutdown occurs (thermal shutdown or current limit). After all faults are cleared, the LATCH pin is low, and the retry timer has expired, the device will transition out of Fault state. If the relevant ENx pin is high, the switch will re-enable. If the relevant ENx pin is low, the switch will remain off.

Device Functional Modes (接下页)

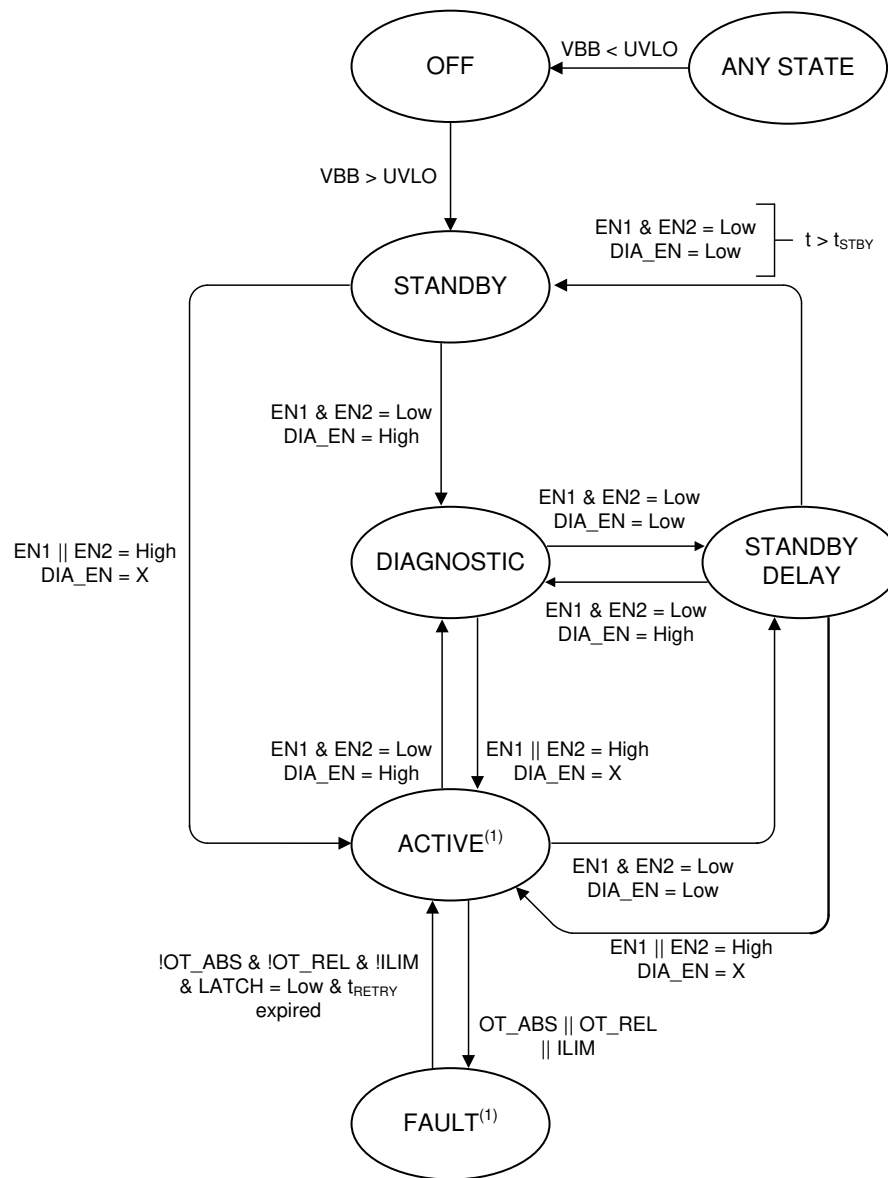

CH1 and CH2 operate independently. Each channel is enabled or disabled independently. Also, if there is a fault on one channel, the other channel is not affected.

图 45. State Diagram

10 Application and Implementation

注

Information in the following applications sections is not part of the TI component specification, and TI does not warrant its accuracy or completeness. TI's customers are responsible for determining suitability of components for their purposes. Customers should validate and test their design implementation to confirm system functionality.

10.1 Application Information

图 46 shows the schematic of a typical application for the TPS2HB16-Q1. It includes all standard external components. This section of the datasheet discusses the considerations in implementing commonly required application functionality. This diagram corresponds to version A of the device. Version F will have minor differences due to the addition of the FLTX pins

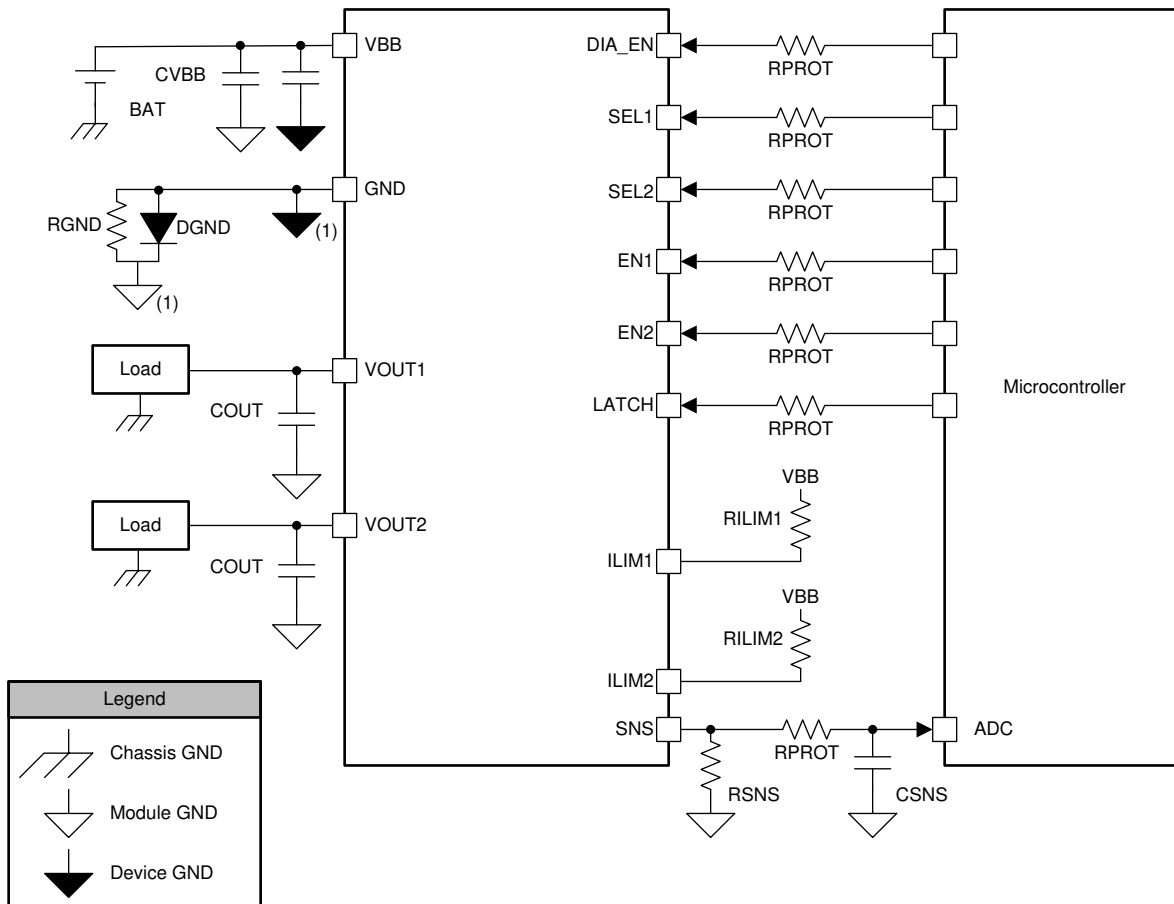

With the ground protection network, the device ground will be offset relative to the microcontroller ground.

图 46. System Diagram

表 6. Recommended External Components

COMPONENT	TYPICAL VALUE	PURPOSE
R_{PROT}	15 k Ω	Protect the microcontroller and device I/O pins.
R_{SNS}	1 k Ω	Translate the sense current into sense voltage.
C_{SNS}	100 pF - 10 nF	Creates Low-pass filter for the ADC input
R_{GND}	4.7 k Ω	Stabilize GND potential during turn-off of inductive load.

Application Information (接下页)

表 6. Recommended External Components (接下页)

COMPONENT	TYPICAL VALUE	PURPOSE
D _{GND}	BAS21 Diode	Protect the device during reverse battery.
R _{LIM}	5 kΩ - 25 kΩ	Set the current limit threshold.
C _{VBB}	4.7 nF to Device GND	Filters voltage transients (for example, ESD, ISO7637-2) and improves emissions
	220 nF to Module GND	Stabilize the input supply and filter out low frequency noise.
C _{OUT}	220 nF	Filters voltage transients (for example, ESD, ISO7637-2)

10.1.1 Ground Protection Network

As discussed in the [Reverse Battery](#) section, D_{GND} may be used to prevent excessive reverse current from flowing into the device during a reverse battery event. Additionally, R_{GND} is placed in parallel with D_{GND} if the switch is used to drive an inductive load. The ground protection network (D_{GND} and R_{GND}) may be shared amongst multiple high-side switches.

A minimum value for R_{GND} may be calculated by using the absolute maximum rating for I_{GND}. During the reverse battery condition, I_{GND} = V_{BB} / R_{GND}:

$$R_{GND} \geq V_{BB} / I_{GND}$$

- Set V_{BB} = -13.5 V
- Set I_{GND} = -50 mA (absolute maximum rating)

$$R_{GND} \geq -13.5 \text{ V} / -50 \text{ mA} = 270 \ \Omega \quad (2)$$

In this example, it is found that R_{GND} must be at least 270 Ω. It is also necessary to consider the power dissipation in R_{GND} during the reverse battery event:

$$P_{RGND} = V_{BB}^2 / R_{GND} \quad (3)$$

$$P_{RGND} = (13.5 \text{ V})^2 / 270 \ \Omega = 0.675 \text{ W}$$

In practice, R_{GND} may not be rated for such a high power. In this case, a larger resistor value should be selected.

10.1.2 Interface With Microcontroller

The ground protection network will cause the device ground to be at a higher potential than the module ground (and microcontroller ground). This offset will impact the interface between the device and the microcontroller.

Logic pin voltage will be offset by the forward voltage of the diode. For input pins (for example, EN1), the designer must consider the V_{IH} specification of the switch and the V_{OH} specification of the microcontroller. For a system that *does not* include D_{GND}, it is required that V_{OH} > V_{IH}. For a system that *does* include D_{GND}, it is required that V_{OH} > (V_{IH} + V_F). V_F is the forward voltage of D_{GND}.

The sense resistor, R_{SNS}, should be terminated to the microcontroller ground. In this case, the ADC can accurately measure the SNS signal even if there is an offset between the microcontroller ground and the device ground.

10.1.3 I/O Protection

R_{PROT} is used to protect the microcontroller I/O pins during system-level voltage transients such as ISO pulses or reverse battery. The SNS pin voltage can exceed the ADC input pin maximum voltage if the fault or saturation current causes a high enough voltage drop across the sense resistor. If that can occur in the design (for example, by switching to a high value R_{SNS} to improve ADC input level), then an appropriate external clamp has to be designed to prevent a high voltage at the SNS output and the ADC input.

10.1.4 Inverse Current

Inverse current occurs when 0 V < V_{BB} < V_{OUTx}. In this case, current may flow from V_{OUTx} to V_{BB}. Inverse current cannot be caused by a purely resistive load. However, a capacitive or inductive load can cause inverse current. For example, if there is a significant amount of load capacitance and the V_{BB} node has a transient droop, V_{OUTx} may be greater than V_{BB}.

The TPS2HB16-Q1 will not detect inverse current. When the switch is enabled, inverse current will pass through the switch. When the switch is disabled, inverse current may pass through the MOSFET body diode. The device will continue operating in the normal manner during an inverse current event.

10.1.5 Loss of GND

The ground connection may be lost either on the device level or on the module level. If the ground connection is lost, both switches will be disabled. If the switch was already disabled when the ground connection was lost, the switch will remain disabled. When the ground is reconnected, normal operation will resume.

10.1.6 Automotive Standards

The TPS2HB16-Q1 is designed to be protected against all relevant automotive standards to ensure reliable operations when connected to a 12-V automotive battery.

10.1.6.1 ISO7637-2

The TPS2HB16-Q1 is tested according to the ISO7637-2:2011 (E) standard. The test pulses are applied both with the switches enabled and disabled. The test setup includes only the DUT and minimal external components: C_{VBB} , C_{OUT} , D_{GND} , and R_{GND} .

Status II is defined in ISO 7637-1 Function Performance Status Classification (FPSC) as: *The function does not perform as designed during the test but returns automatically to normal operation after the test.* See 表 7 for ISO7637-2:2011 (E) expected results.

表 7. ISO7637-2:2011 (E) Results

TEST PULSE	TEST PULSE SEVERITY LEVEL WITH STATUS II FUNCTIONAL PERFORMANCE		MINIMUM NUMBER OF PULSES OR TEST TIME	BURST CYCLE / PULSE REPETITION TIME	
	LEVEL	US		MIN	MAX
1	III	-112 V	500 pulses	0.5 s	--
2a ⁽¹⁾	III	+55 V	500 pulses	0.20 s	5 s
2b	IV	+10 V	10 pulses	0.5 s	5 s
3a	IV	-220 V	1 hour	90 ms	100 ms
3b	IV	+150 V	1 hour	90 ms	100 ms

(1) 1 μ F capacitance on C_{VBB} is required for passing level 3 ISO7637 pulse 2 A.

10.1.6.2 AEC – Q100-012 Short Circuit Reliability

The TPS2HB16-Q1 is tested according to the AEC-Q100-012 Short Circuit Reliability standard. This test is performed to demonstrate the robustness of the device against V_{OUT} short-to-ground events. Test conditions and test procedures are summarized in 表 8. For further details, refer to the AEC - Q100-012 standard document.

Test conditions:

- LATCH = 0 V
- $I_{LIM} = N/A$ (Version F)
- 10 units from 3 separate lots for a total of 30 units
- $L_{supply} = 5 \mu H$, $R_{supply} = 10 m\Omega$
- $V_{BB} = 14 V$

Test procedure:

- Parametric data is collected on each unit pre-stress.
- Each unit is enabled into a short-circuit with the required short circuit cycles or duration as specified.
- Functional testing is performed on each unit post-stress to verify that the part still operates as expected.

The cold repetitive test is run at 85°C which is the worst case condition for the device to sustain a short circuit. The cold repetitive test refers to the device being given time to cool down between pulses, rather than being run at a cold temperature. The load short circuit is the worst case situation, since the energy stored in the cable inductance can cause additional harm. The fast response of the device ensures current limiting occurs quickly and at a current close to the load short condition. In addition, the hot repetitive test is performed as well.

表 8. AEC - Q100-012 Test Results

TEST	LOCATION OF SHORT	DEVICE VERSION	NO. OF CYCLES / DURATION	NO. OF UNITS	NO. OF FAILS
Cold Repetitive - Long Pulse	Load Short Circuit, $L_{short} = 5 \mu\text{H}$, $R_{short} = 100 \text{ m}\Omega$, $T_A = 85^\circ\text{C}$	F	100 k cycles	30	0
Hot Repetitive - Long Pulse	Load Short Circuit, $L_{short} = 5 \mu\text{H}$, $R_{short} = 100 \text{ m}\Omega$, $T_A = 25^\circ\text{C}$	F	100 hours	30	0

10.1.7 Thermal Information

When outputting current, the TPS2HB16-Q1 will heat up due to the power dissipation. The transient thermal impedance curve can be used to determine the device temperature during a pulse of a given length. This $R_{\theta JA}$ value corresponds to a JEDEC standard 2s2p thermal test PCB with thermal vias. The $R_{\theta JA}$ will vary depending on whether the power dissipation is concentrated in a single channel or is distributed evenly between each channel.



图 47. TPS2HB16-Q1 Transient Thermal Impedance

10.2 Typical Application

This application example demonstrates how the TPS1HB16-Q1 device can be used to power bulb loads in automotive headlights. In this example, we consider a 27 W that is powered by the device. This is just one example of the many applications where this device can fit.

Typical Application (接下页)

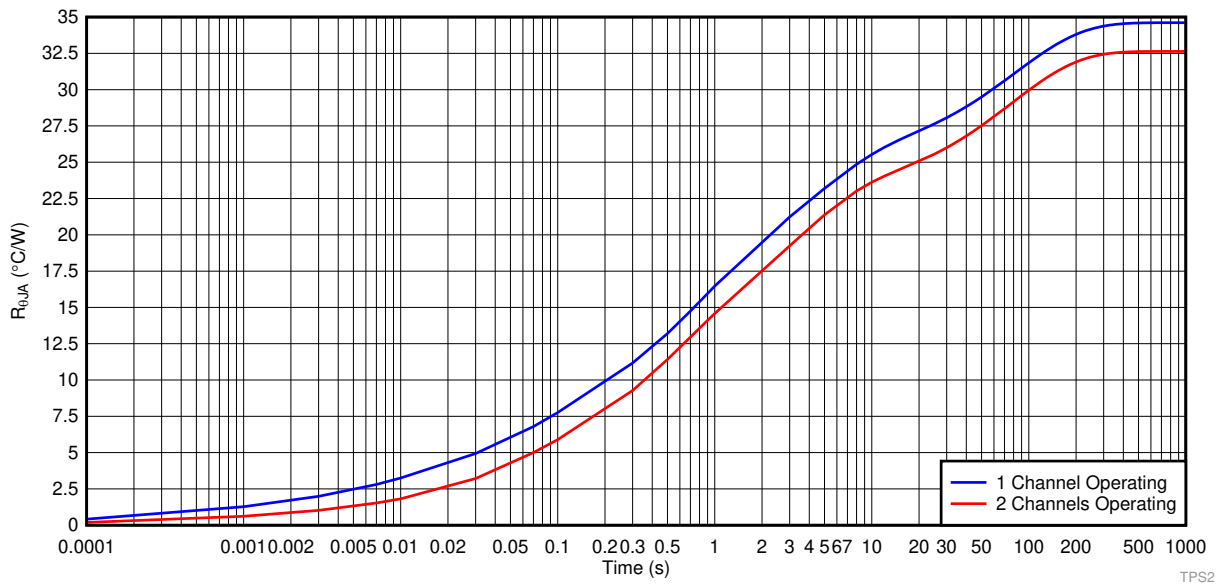

图 48. Block Diagram for Driving Bulb Load

10.2.1 Design Requirements

For this design example, use the input parameters shown in 表 9.

表 9. Design Parameters

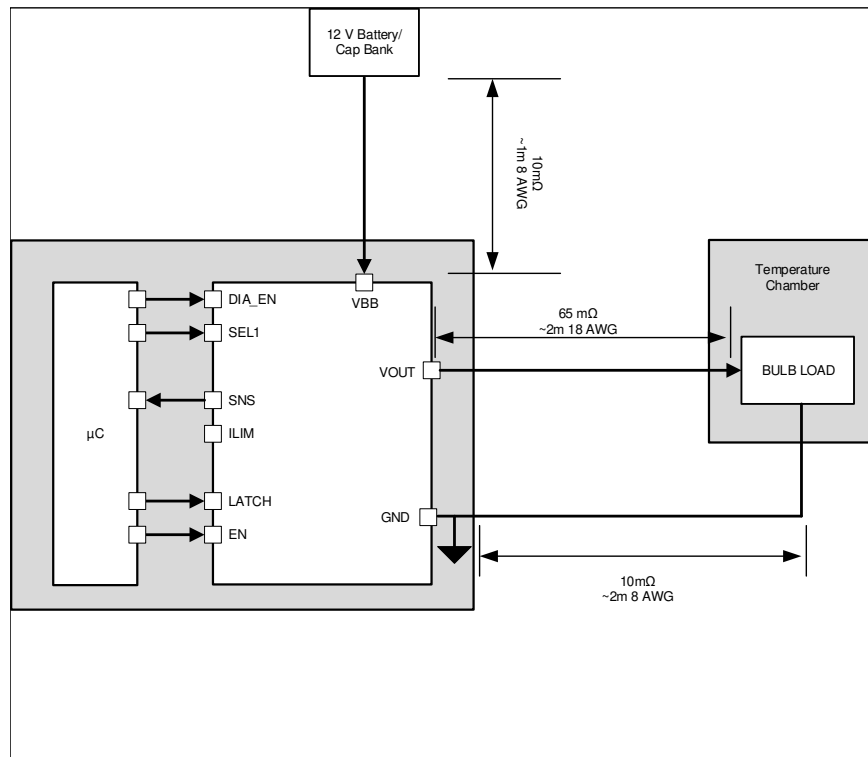
DESIGN PARAMETER	EXAMPLE VALUE
V_{BB}	16 V
Load - Bulb	2x27 W
Fixed I_{LIM}	60 A
Ambient temperature	25°C
Bulb Temperature in Chamber	-40°C
Cable Impedance from Device to Bulb	65 mΩ
Device Version	F

10.2.2 Detailed Design Procedure

The typical bulb test setup is where the device is at 25°C and the bulb is in a temperature chamber at -40°C. The bulb needs to be kept at -40°C so that the impedance is very low and the inrush current will be the highest. The impedance of the cables is important because it will change the inrush current of the bulb as well. The F version of the TPS2HB16-Q1 has a very high fixed current limit so that the inrush current of the bulb can be passed without limitation.

TPS2HB16-Q1

ZHCSJN4C – FEBRUARY 2018 – REVISED FEBRUARY 2020

www.ti.com.cn

10.2.3 Application Curves



图 49. TPS2HB16-Q1 Version F Driving 2x27 W Bulb Inrush



图 50. TPS2HB16-Q1 Version F Driving Single 27 W Bulb Inrush

10.2.4 Design Requirements

For this design example, use the input parameters shown in 表 10.

表 10. Design Parameters

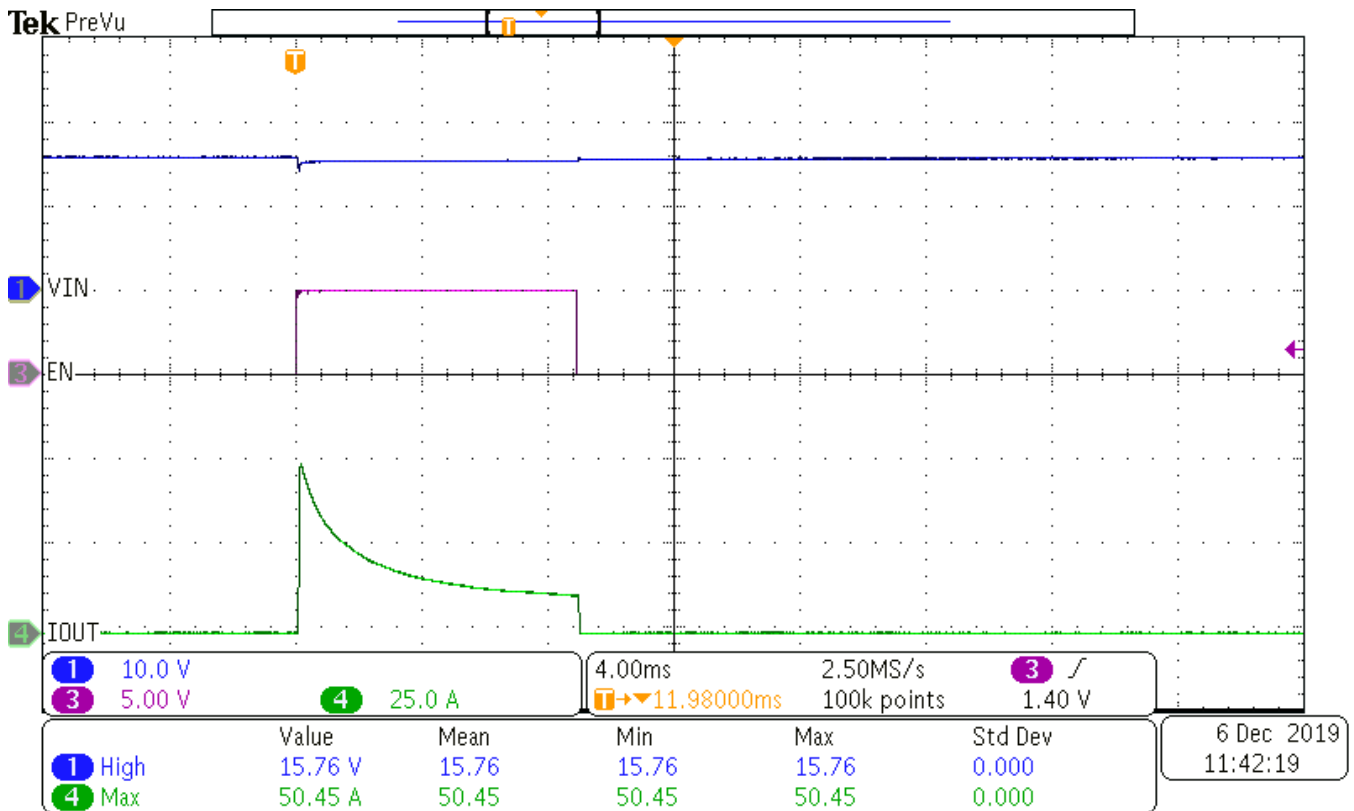
DESIGN PARAMETER	EXAMPLE VALUE
V_{BB}	16 V
Load - Bulb	2x27 W
Fixed I_{LIM}	60 A
Ambient temperature	105°C
Bulb Temperature in Chamber	25°C
Cable Impedance from Device to Bulb	65 mΩ
Device Version	F

10.2.5 Detailed Design Procedure

The another typical bulb test is to have the bulbs at room temperature (25°C) and the device heated up to 105°C. This test is designed see if the device can drive the bulbs without hitting thermal shutdown due to the current draw of the bulbs. The passing criteria is that the bulb illuminates when the device enables the channels and the device does not go into thermal shutdown. 图 51 shows the current waveform of this test and as it can be seen the bulb comes on and stays on without hitting thermal shutdown. Notice that the current is lower in this condition than the inrush condition. This is due to the bulbs effective capacitance being lower at higher temperatures as expected.

10.2.6 Application Curves



图 51. TPS2HB16-Q1 Version F 2x27W Bulb Turn On

10.3 Typical Application

This application example demonstrates how the TPS2HB16-Q1 device can be used to power resistive heater loads in automotive seats. In this example, we consider dual heater loads that are powered independently by the two channels of the device. A dual-channel device is the ideal solution as it will yield a smaller solution size relative to two single-channel devices.

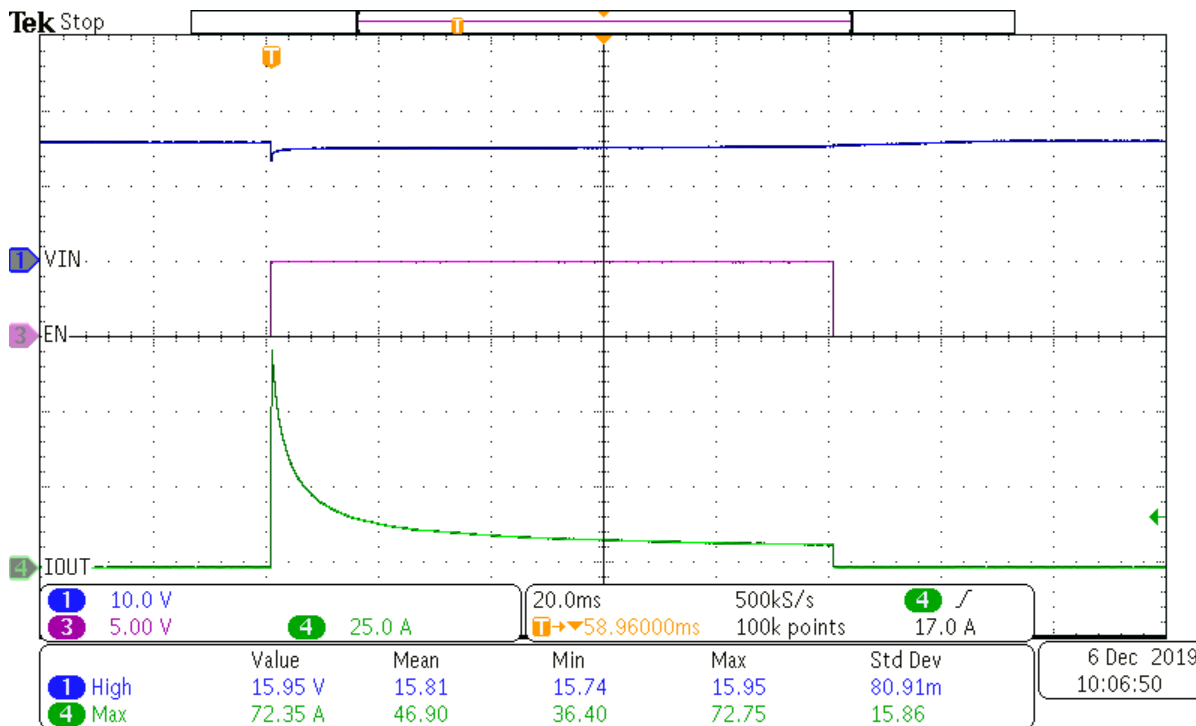

图 52. Block Diagram for Powering Dual Heater Loads

10.3.1 Design Requirements

For this design example, use the input parameters shown in 表 11.

表 11. Design Parameters

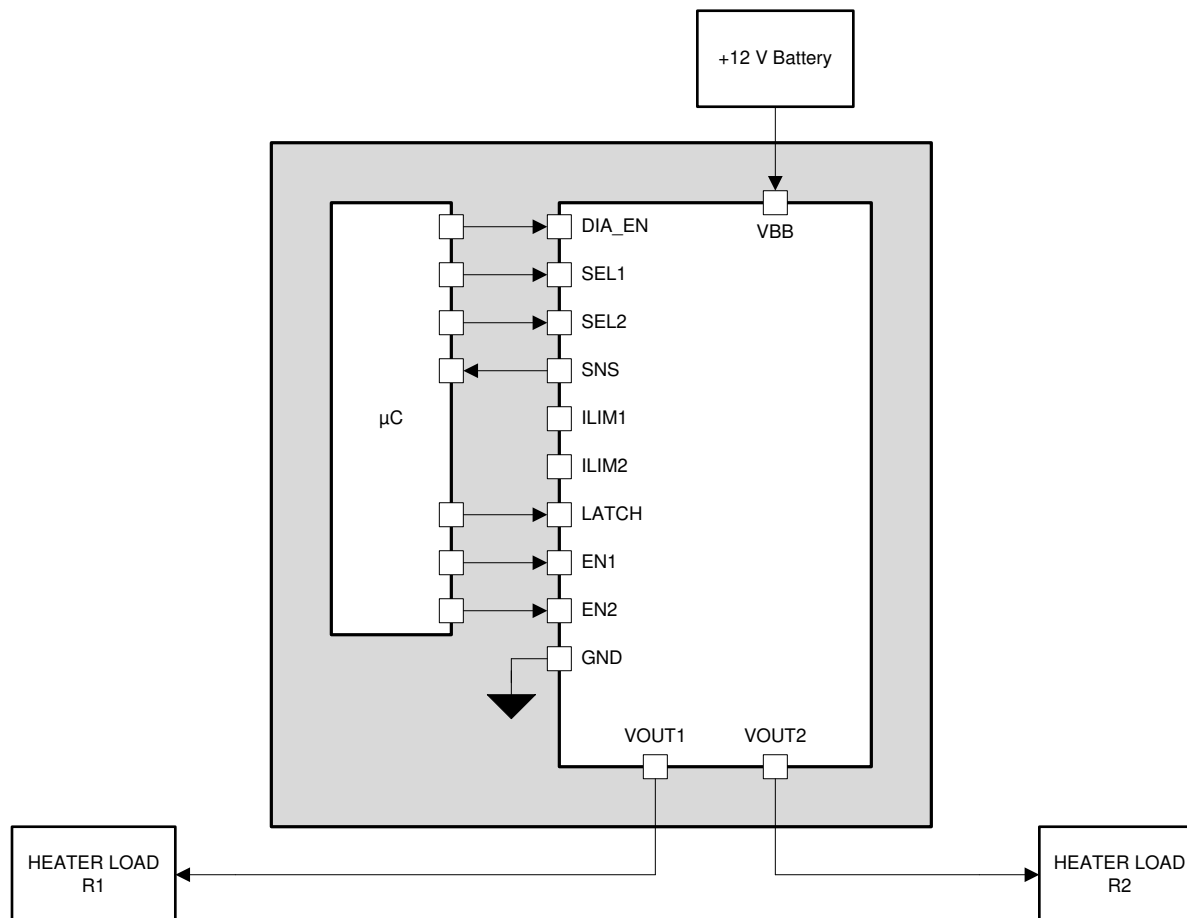
DESIGN PARAMETER	EXAMPLE VALUE
V_{BB}	13.5 V
Load Ch1 - Heater 1	55 W max
Load Ch2 - Heater 2	55 W max
Load Current Sense	60 mA to 12 A
I_{LIM}	6 A
Ambient temperature	70°C
$R_{\theta JA}$	32.5°C/W (depending on PCB)
Device Version	A

10.3.2 Detailed Design Procedure

10.3.2.1 Thermal Considerations

The DC current in each channel under maximum load power condition will be around 4.1 A. Both heater loads can be ON at the same time, so the case where both channels are enabled simultaneously is considered to assume worst case heating.

Power dissipation in the switch is calculated in [公式 4](#). R_{ON} is assumed to be 40 mΩ because this is the maximum specification at high temperature. In practice, R_{ON} will almost always be lower.

$$P_{FET} = I^2 \times R_{ON} \quad (4)$$

$$P_{FET} = (4.1 \text{ A})^2 \times 40 \text{ m}\Omega = 0.67 \text{ W} \quad (5)$$

If both channels are enabled, then the total power dissipation is 1.34 W. The junction temperature of the device can be calculated using [公式 6](#) and the $R_{\theta JA}$ value from the [Specifications](#) section.

$$T_J = T_A + R_{\theta JA} \times P_{FET} \quad (6)$$

$$T_J = 70^\circ\text{C} + 32.5^\circ\text{C/W} \times 1.34 \text{ W} = 113.5^\circ\text{C}$$

The maximum junction temperature rating for the TPS2HB16-Q1 device is $T_J = 150^\circ\text{C}$. Based on the above example calculation, the device temperature will stay below the maximum rating.

10.3.2.2 R_{ILIM} Calculation

In this application, the TPS2HB16-Q1 must allow for the maximum 4.1-A current with margin but minimize the energy in the switch during a fault condition by minimizing the current limit. For this application, the best I_{LIM} set point is approximately 6 A. [公式 7](#) allows you to calculate the R_{ILIM} value that is placed from the I_{LIMX} pins to V_{BB} . R_{ILIM} is calculated in kΩ.

$$R_{ILIM} = K_{CL} / I_{CL} \quad (7)$$

Because this device is version A, the K_{CL} value in the [Specifications](#) section is 102 A × kΩ.

$$R_{ILIM} = 102 \text{ A} \times \text{k}\Omega / 6 \text{ A} = 17 \text{ k}\Omega \quad (8)$$

For a I_{LIM} of 6 A, the R_{ILIM} value should be set at approximately 17 kΩ.

10.3.2.3 Diagnostics

If the resistive heating load is disconnected (heater malfunction), an alert is desired. Open-load detection can be performed in the switch-enabled state with the current sense feature of the TPS2HB16-Q1 device. Under open load condition, the current in the SNS pin will be the fault current and this can be detected from the sense voltage measurement.

10.3.2.3.1 Selecting the R_{SNS} Value

[表 12](#) shows the requirements for the load current sense in this application. The K_{SNS} value is specified for the device and can be found in the [Specifications](#) section.

表 12. R_{SNS} Calculation Parameters

PARAMETER	EXAMPLE VALUE
Current Sense Ratio (K_{SNS})	3000
Largest diagnosable load current	12 A
Smallest diagnosable load current	60 mA
Full-scale ADC voltage	5-V
ADC resolution	10-bit

The load current measurement requirements of 12 A ensures that even in the event of a overcurrent surpassing the device internal 6-A limit, the MCU can register and react by shutting down the TPS2HB16-Q1, while the low level of 60 mA allows for accurate measurement of low load currents.

The R_{SNS} resistor value should be selected such that the largest diagnosable load current puts V_{SNS} at about 95% of the ADC full-scale. With this design, any ADC value above 95% can be considered a fault. Additionally, the R_{SNS} resistor value should ensure that the smallest diagnosable load current does not cause V_{SNS} to fall below 1 LSB of the ADC. With the given example values, a 1.2-k Ω sense resistor satisfies both requirements shown in 表 13.

表 13. V_{SNS} Calculation

LOAD (A)	SENSE RATIO	I_{SNS} (mA)	R_{SNS} (Ω)	V_{SNS} (V)	% of 5-V ADC
0.060	3000	0.02	1200	0.024	0.5%
12	3000	4	1200	4.800	96.0%

10.3.3 Application Curves

When the device receives a rising edge on the ENx pulse the output will turn on as shown in 图 53. After the turn-on delay time, the device V_{OUT} goes to the V_{BB} supply and begins outputting the steady state resistive current.

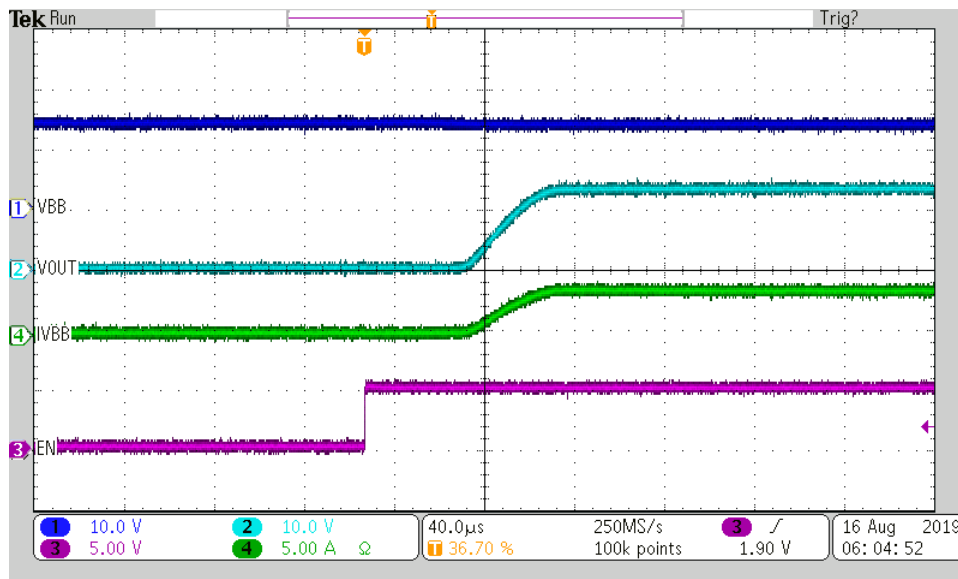
图 53. Turn On Waveform

When the device turns off on a falling edge of ENx, the channel I_{OUT} will go to zero and the V_{OUT} will drop to zero as well as shown in 图 54.



图 54. Turn-Off Waveform

While enabled, it is important to measure the output current through both channels. 图 55 shows this behavior when toggling the SELx pins. The image shows that when SEL2 toggles high to low, the SNS pin toggles between representing I_{OUT1} and I_{OUT2} . When SEL2 is low SNS represents I_{OUT1} and when SEL2 is high SNS represents I_{OUT2} . This image shows that channel 2 is currently outputting twice the output current as channel 1.

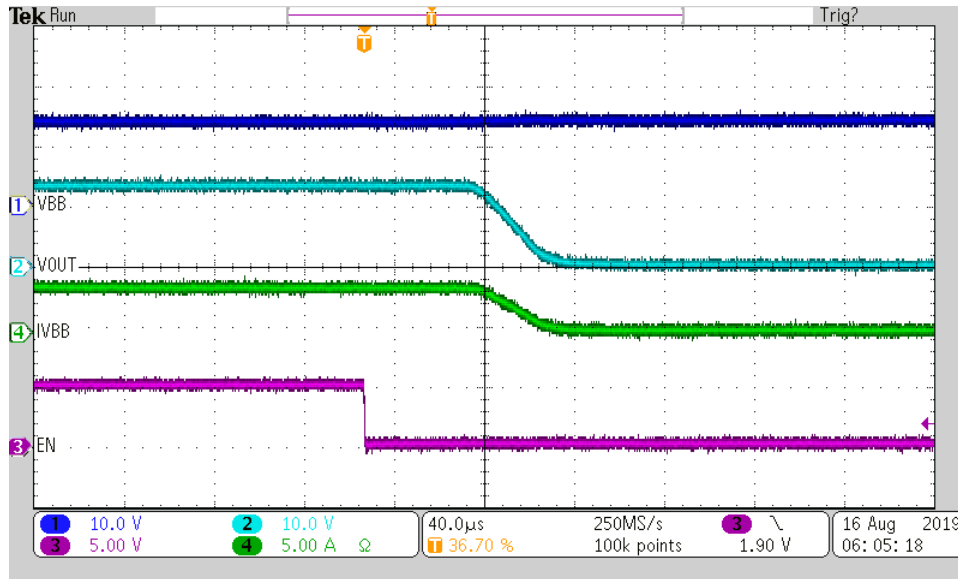

图 55. Toggling Between CH1 and CH2 Current Measurement

图 56 shows the SNS current behavior when there is a load step. The image shows the output current temporarily increase from 1 A to 5 A and then return to 1 A. In this situation, the output current is accurately modeled throughout the pulse by the voltage on the SNS pin allowing for accurate diagnostics.

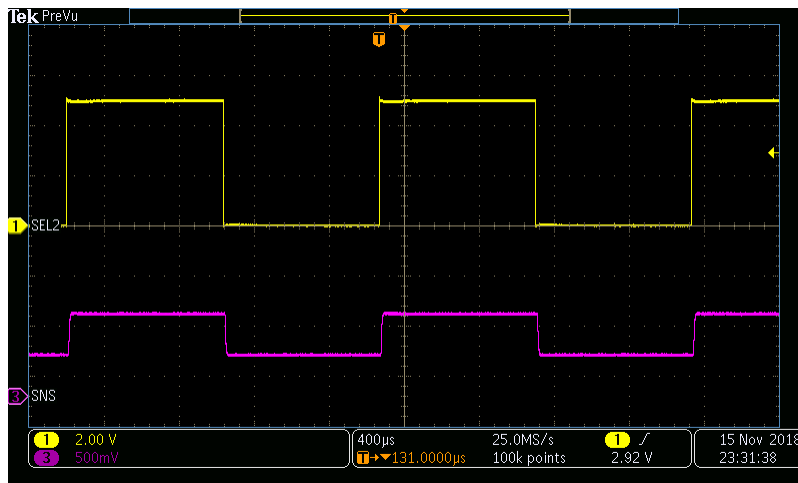

图 56. SNS Settling Time

If the output of the TPS2HB16-Q1 is short-circuited, the device will protect the system from failure. shows the device turning off the output at a set current limit when the output is short circuited. (Note: shows a case with a higher R_{ILIM} than calculated in this example, so the current limit is higher than).

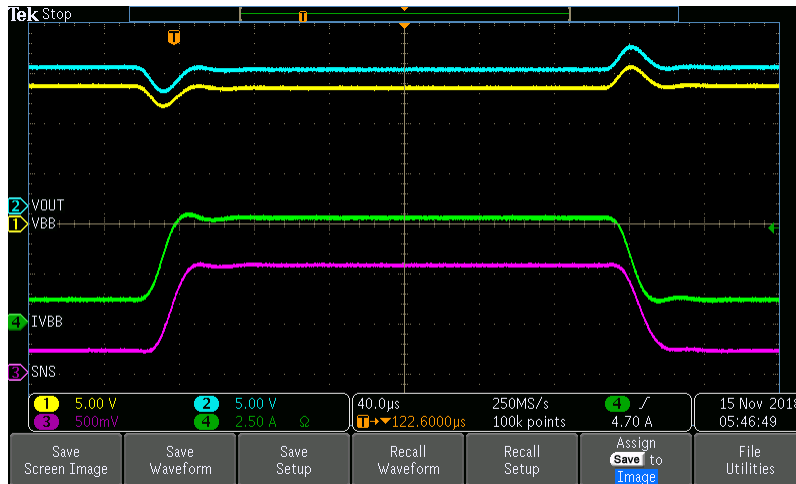

图 57. TPS2HB16B-Q1 Short Circuit Waveform

11 Power Supply Recommendations

The TPS2HB16-Q1 device is designed to operate in a 12-V automotive system. The nominal supply voltage range is 6 V to 18 V as measured at the V_{BB} pin with respect to the GND pin of the device. In this range the device meets full parametric specifications as listed in the [Electrical Characteristics](#) table. The device is also designed to withstand voltage transients beyond this range. When operating outside of the nominal voltage range but within the operating voltage range, the device will exhibit normal functional behavior. However, parametric specifications may not be specified outside the nominal supply voltage range.

表 14. Operating Voltage Range

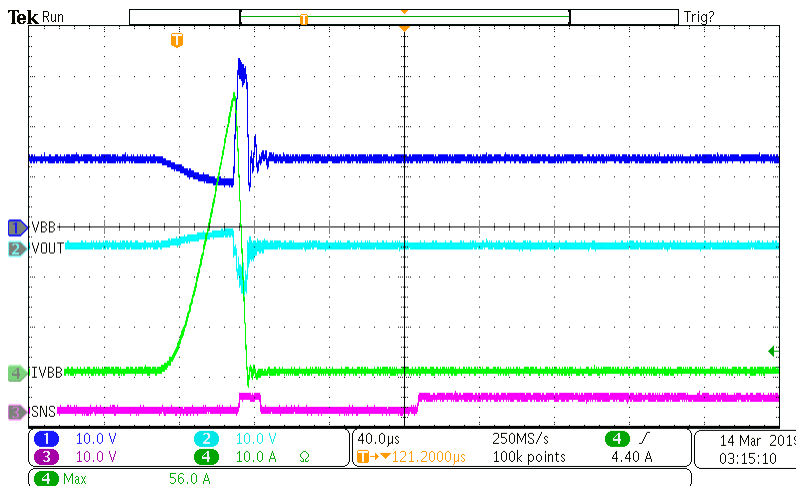
V_{BB} Voltage Range	Note
3 V to 6 V	Transients such as cold crank and start-stop, functional operation are specified but some parametric specifications may not apply. The device is completely short-circuit protected up to 125°C.

表 14. Operating Voltage Range (接下页)

V_{BB} Voltage Range	Note
6 V to 18 V	Nominal supply voltage, all parametric specifications apply. The device is completely short-circuit protected up to 125°C.
18 V to 40 V	Transients such as jump-start and load-dump, functional operation specified but some parametric specifications may not apply.

12 Layout

12.1 Layout Guidelines

To achieve optimal thermal performance, connect the exposed pad to a large copper pour. On the top PCB layer, the pour may extend beyond the package dimensions as shown in the example below. In addition to this, it is recommended to have a V_{BB} plane either on one of the internal PCB layers or on the bottom layer.

Vias should connect this plane to the top V_{BB} pour.

Ensure that all external components are placed close to the pins. Device current limiting performance can be harmed if the R_{ILIM} is far from the pins and extra parasitics are introduced.

12.2 Layout Example

The layout example shown below is for device versions A/B.

For version F, there will be minor differences due to the open-drain $\overline{FLT1}$ and $\overline{FLT2}$ pins and the removal of the ILIM1 and ILIM2 pins.



图 58. PWP Layout Example

13 器件和文档支持

13.1 文档支持

13.1.1 相关文档

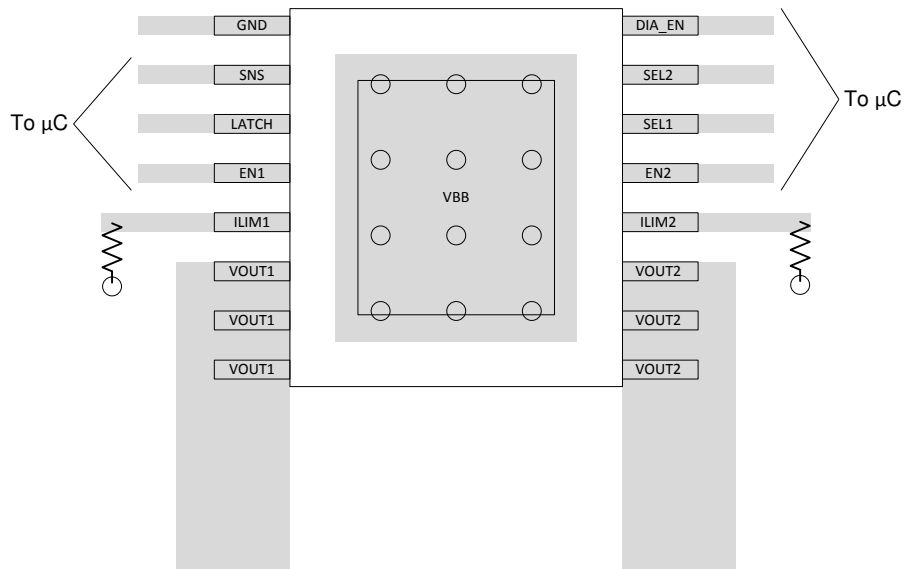
请参阅如下相关文档：

- TI 《如何利用智能高侧开关驱动电感、电容和照明负载》
- TI 《智能电源开关的短路可靠性测试》
- TI 《智能电源开关的可调电流限制》
- TI 《TPS2HB35-Q1 40V、35mΩ 双通道智能高侧开关》
- TI 《使用可调电流限制提高汽车短路可靠性》

13.2 接收文档更新通知

要接收文档更新通知，请导航至 ti.com.cn 上的器件产品文件夹。单击右上角的通知我进行注册，即可每周接收产品信息更改摘要。有关更改的详细信息，请查看任何已修订文档中包含的修订历史记录。

13.3 支持资源

TI E2E™ support forums are an engineer's go-to source for fast, verified answers and design help — straight from the experts. Search existing answers or ask your own question to get the quick design help you need.

Linked content is provided "AS IS" by the respective contributors. They do not constitute TI specifications and do not necessarily reflect TI's views; see TI's [Terms of Use](#).

13.4 商标

E2E is a trademark of Texas Instruments.

All other trademarks are the property of their respective owners.

13.5 静电放电警告



ESD 可能会损坏该集成电路。德州仪器 (TI) 建议通过适当的预防措施处理所有集成电路。如果不遵守正确的处理措施和安装程序，可能会损坏集成电路。

ESD 的损坏小至导致微小的性能降级，大至整个器件故障。精密的集成电路可能更容易受到损坏，这是因为非常细微的参数更改都可能会导致器件与其发布的规格不相符。

13.6 Glossary

[SLYZ022](#) — TI Glossary.

This glossary lists and explains terms, acronyms, and definitions.

14 机械、封装和可订购信息

以下页面包含机械、封装和可订购信息。这些信息是指定器件的最新可用数据。数据如有变更，恕不另行通知，且不会对此文档进行修订。如需获取此数据表的浏览器版本，请查阅左侧的导航栏。

重要声明和免责声明



TI 均以“原样”提供技术性数据（包括数据表）、设计资源（包括参考设计）、应用或其他设计建议、网络工具、安全信息和其他资源，不保证其中不含任何瑕疵，且不做任何明示或暗示的担保，包括但不限于对适销性、适合某特定用途或不侵犯任何第三方知识产权的暗示担保。

所述资源可供专业开发人员应用TI 产品进行设计使用。您将对以下行为独自承担全部责任：(1) 针对您的应用选择合适的TI 产品；(2) 设计、验证并测试您的应用；(3) 确保您的应用满足相应标准以及任何其他安全、安保或其他要求。所述资源如有变更，恕不另行通知。TI 对您使用所述资源的授权仅限于开发资源所涉及TI 产品的相关应用。除此之外不得复制或展示所述资源，也不提供其它TI 或任何第三方的知识产权授权许可。如因使用所述资源而产生任何索赔、赔偿、成本、损失及债务等，TI 对此概不负责，并且您须赔偿由此对TI 及其代表造成的损害。

TI 所提供产品均受TI 的销售条款 (<http://www.ti.com.cn/zh-cn/legal/termsofsale.html>) 以及ti.com.cn上或随附TI产品提供的其他可适用条款的约束。TI提供所述资源并不扩展或以其他方式更改TI 针对TI 产品所发布的可适用的担保范围或担保免责声明。

邮寄地址：上海市浦东新区世纪大道 1568 号中建大厦 32 楼，邮政编码：200122
Copyright © 2020 德州仪器半导体技术（上海）有限公司

PACKAGING INFORMATION

Orderable Device	Status (1)	Package Type	Package Drawing	Pins	Package Qty	Eco Plan (2)	Lead finish/ Ball material (6)	MSL Peak Temp (3)	Op Temp (°C)	Device Marking (4/5)	Samples
TPS2HB16AQPWPRQ1	ACTIVE	HTSSOP	PWP	16	3000	RoHS-Exempt & Green	NIPDAU	Level-3-260C-168HRS	-40 to 125	2HB16AQ	
TPS2HB16BQPWPRQ1	ACTIVE	HTSSOP	PWP	16	3000	RoHS-Exempt & Green	NIPDAU	Level-3-260C-168HRS	-40 to 125	2HB16BQ	
TPS2HB16FQPWPRQ1	ACTIVE	HTSSOP	PWP	16	3000	RoHS-Exempt & Green	NIPDAU	Level-3-260C-168HRS	-40 to 125	2HB16FQ	

(1) The marketing status values are defined as follows:

ACTIVE: Product device recommended for new designs.

LIFEBUY: TI has announced that the device will be discontinued, and a lifetime-buy period is in effect.

NRND: Not recommended for new designs. Device is in production to support existing customers, but TI does not recommend using this part in a new design.

PREVIEW: Device has been announced but is not in production. Samples may or may not be available.

OBSOLETE: TI has discontinued the production of the device.

(2) **RoHS:** TI defines "RoHS" to mean semiconductor products that are compliant with the current EU RoHS requirements for all 10 RoHS substances, including the requirement that RoHS substance do not exceed 0.1% by weight in homogeneous materials. Where designed to be soldered at high temperatures, "RoHS" products are suitable for use in specified lead-free processes. TI may reference these types of products as "Pb-Free".

RoHS Exempt: TI defines "RoHS Exempt" to mean products that contain lead but are compliant with EU RoHS pursuant to a specific EU RoHS exemption.

Green: TI defines "Green" to mean the content of Chlorine (Cl) and Bromine (Br) based flame retardants meet JS709B low halogen requirements of <=1000ppm threshold. Antimony trioxide based flame retardants must also meet the <=1000ppm threshold requirement.

(3) MSL, Peak Temp. - The Moisture Sensitivity Level rating according to the JEDEC industry standard classifications, and peak solder temperature.

(4) There may be additional marking, which relates to the logo, the lot trace code information, or the environmental category on the device.

(5) Multiple Device Markings will be inside parentheses. Only one Device Marking contained in parentheses and separated by a "~" will appear on a device. If a line is indented then it is a continuation of the previous line and the two combined represent the entire Device Marking for that device.

(6) Lead finish/Ball material - Orderable Devices may have multiple material finish options. Finish options are separated by a vertical ruled line. Lead finish/Ball material values may wrap to two lines if the finish value exceeds the maximum column width.

Important Information and Disclaimer:The information provided on this page represents TI's knowledge and belief as of the date that it is provided. TI bases its knowledge and belief on information provided by third parties, and makes no representation or warranty as to the accuracy of such information. Efforts are underway to better integrate information from third parties. TI has taken and continues to take reasonable steps to provide representative and accurate information but may not have conducted destructive testing or chemical analysis on incoming materials and chemicals. TI and TI suppliers consider certain information to be proprietary, and thus CAS numbers and other limited information may not be available for release.

In no event shall TI's liability arising out of such information exceed the total purchase price of the TI part(s) at issue in this document sold by TI to Customer on an annual basis.

TAPE AND REEL INFORMATION



QUADRANT ASSIGNMENTS FOR PIN 1 ORIENTATION IN TAPE



*All dimensions are nominal

Device	Package Type	Package Drawing	Pins	SPQ	Reel Diameter (mm)	Reel Width W1 (mm)	A0 (mm)	B0 (mm)	K0 (mm)	P1 (mm)	W (mm)	Pin1 Quadrant
TPS2HB16AQPWRQ1	HTSSOP	PWP	16	3000	330.0	12.4	6.9	5.6	1.6	8.0	12.0	Q1
TPS2HB16BQPWRQ1	HTSSOP	PWP	16	3000	330.0	12.4	6.9	5.6	1.6	8.0	12.0	Q1
TPS2HB16FQPWRQ1	HTSSOP	PWP	16	3000	330.0	12.4	6.9	5.6	1.6	8.0	12.0	Q1

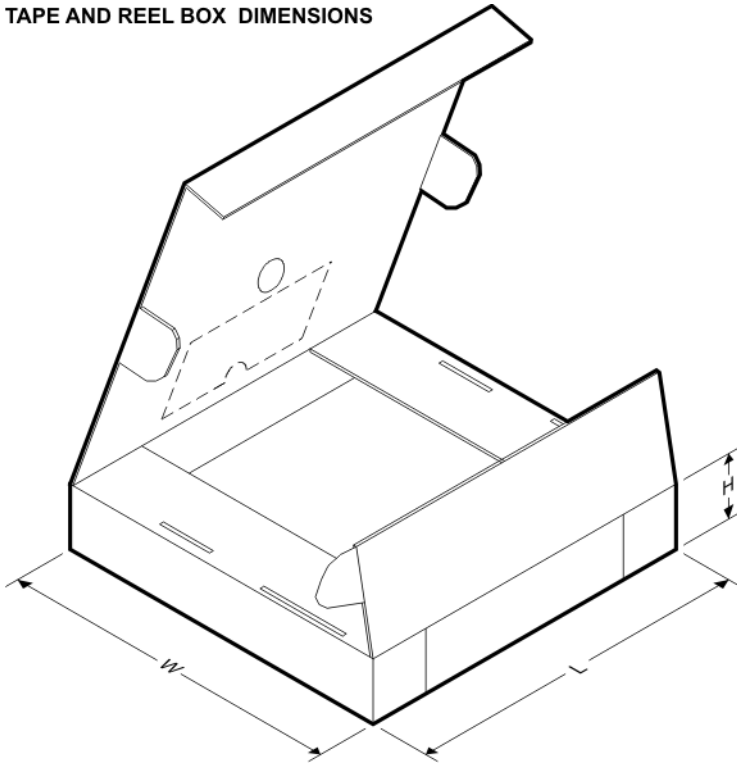
TAPE AND REEL BOX DIMENSIONS

*All dimensions are nominal

Device	Package Type	Package Drawing	Pins	SPQ	Length (mm)	Width (mm)	Height (mm)
TPS2HB16AQPWRQ1	HTSSOP	PWP	16	3000	350.0	350.0	43.0
TPS2HB16BQPWRQ1	HTSSOP	PWP	16	3000	350.0	350.0	43.0
TPS2HB16FQPWRQ1	HTSSOP	PWP	16	3000	350.0	350.0	43.0

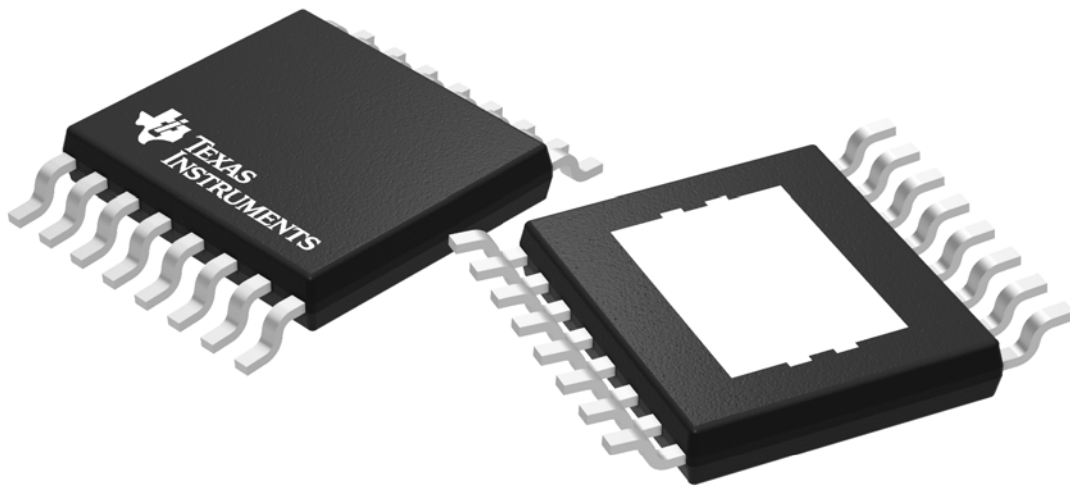

Images above are just a representation of the package family, actual package may vary.
Refer to the product data sheet for package details.

EXAMPLE BOARD LAYOUT

PWP0016M

PowerPAD™ TSSOP - 1.2 mm max height

SMALL OUTLINE PACKAGE

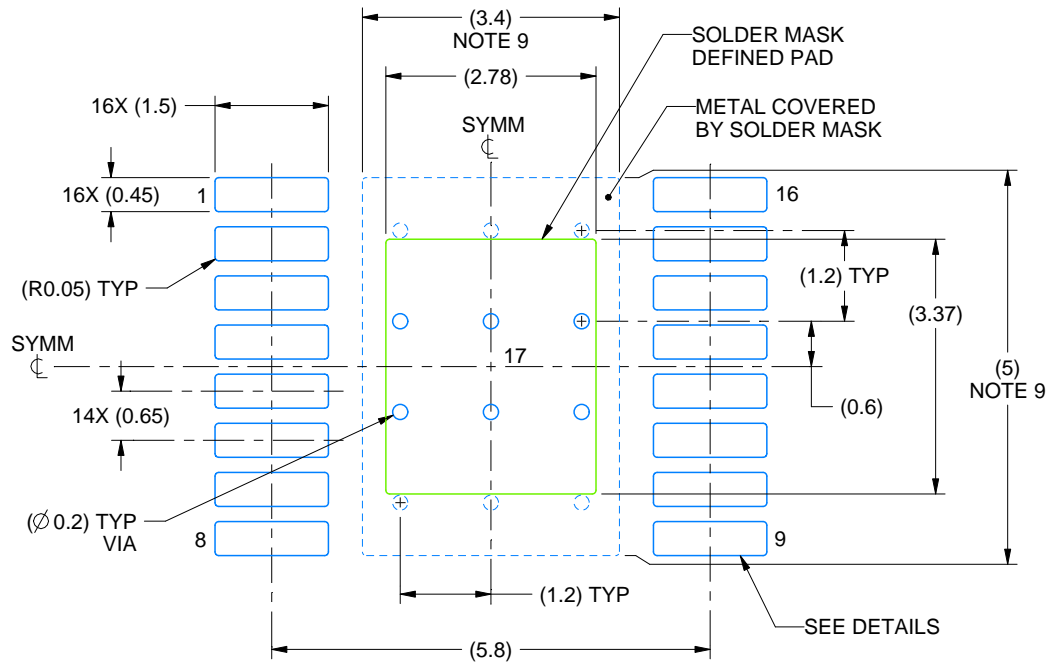

LAND PATTERN EXAMPLE
EXPOSED METAL SHOWN
SCALE: 10X

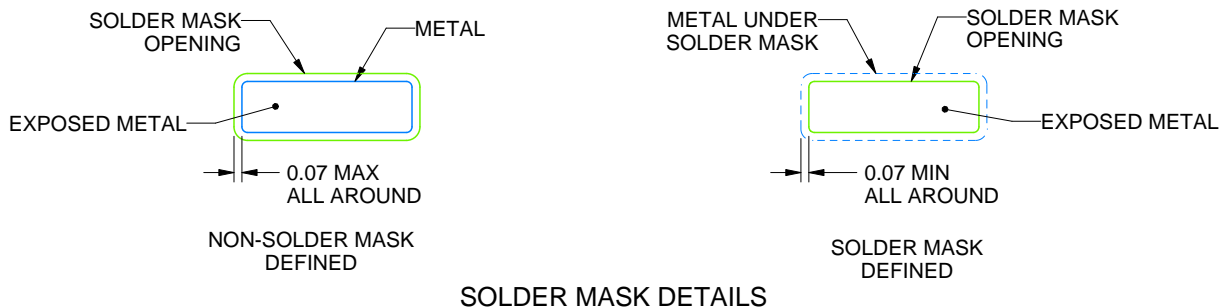

SOLDER MASK DETAILS

4223886/B 09/2019

NOTES: (continued)

6. Publication IPC-7351 may have alternate designs.
7. Solder mask tolerances between and around signal pads can vary based on board fabrication site.
8. This package is designed to be soldered to a thermal pad on the board. For more information, see Texas Instruments literature numbers SLMA002 (www.ti.com/lit/slma002) and SLMA004 (www.ti.com/lit/slma004).
9. Size of metal pad may vary due to creepage requirement.
10. Vias are optional depending on application, refer to device data sheet. It is recommended that vias under paste be filled, plugged or tented.

EXAMPLE STENCIL DESIGN

PWP0016M

PowerPAD™ TSSOP - 1.2 mm max height

SMALL OUTLINE PACKAGE

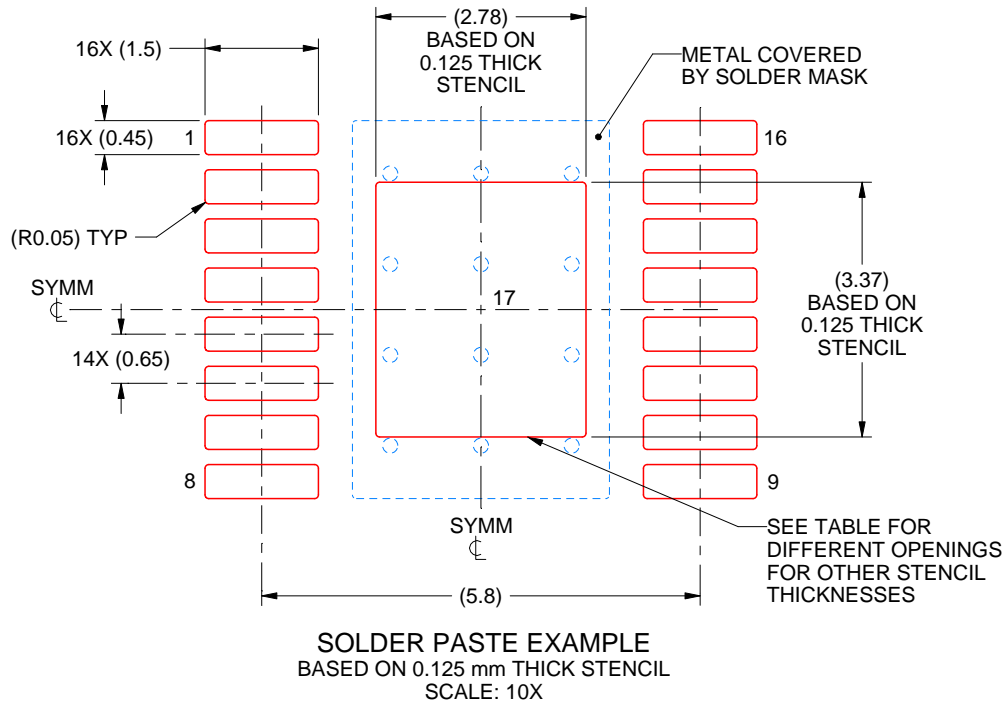

STENCIL THICKNESS	SOLDER STENCIL OPENING
0.1	3.11 X 3.77
0.125	2.78 X 3.37 (SHOWN)
0.15	2.54 X 3.08
0.175	2.35 X 2.85

4223886/B 09/2019

NOTES: (continued)

11. Laser cutting apertures with trapezoidal walls and rounded corners may offer better paste release. IPC-7525 may have alternate design recommendations.
12. Board assembly site may have different recommendations for stencil design.

重要声明和免责声明

TI 均以“原样”提供技术性及其可靠性数据（包括数据表）、设计资源（包括参考设计）、应用或其他设计建议、网络工具、安全信息和其他资源，不保证其中不含任何瑕疵，且不做任何明示或暗示的担保，包括但不限于对适销性、适合某特定用途或不侵犯任何第三方知识产权的暗示担保。

所述资源可供专业开发人员应用TI 产品进行设计使用。您将对以下行为独自承担全部责任：(1) 针对您的应用选择合适的TI 产品；(2) 设计、验证并测试您的应用；(3) 确保您的应用满足相应标准以及任何其他安全、安保或其他要求。所述资源如有变更，恕不另行通知。TI 对您使用所述资源的授权仅限于开发资源所涉及TI 产品的相关应用。除此之外不得复制或展示所述资源，也不提供其它TI 或任何第三方的知识产权授权许可。如因使用所述资源而产生任何索赔、赔偿、成本、损失及债务等，TI 对此概不负责，并且您须赔偿由此对TI 及其代表造成的损害。

TI 所提供产品均受TI 的销售条款 (<http://www.ti.com.cn/zh-cn/legal/termsofsale.html>) 以及ti.com.cn 上或随附TI 产品提供的其他可适用条款的约束。TI 提供所述资源并不扩展或以其他方式更改TI 针对TI 产品所发布的可适用的担保范围或担保免责声明。

邮寄地址：上海市浦东新区世纪大道 1568 号中建大厦 32 楼，邮政编码：200122

Copyright © 2020 德州仪器半导体技术（上海）有限公司