

# 具有可配置电压转换和三态输出的 SN74AXC4T245-Q1 汽车 4 位双电源总线收发器

## 1 特性

- 符合面向汽车应用的 AEC-Q100 标准
- 采用可湿侧面 QFN (WBQB) 封装
- 完全可配置的双轨设计可允许各个端口在 0.65V 至 3.6V 的电源电压范围内运行
- 工作温度范围为 -40°C 至 +125°C
- 多向控制引脚，支持同步升降转换
- 无干扰电源定序
- 从 1.8V 转换到 3.3V 时，支持高达 380Mbps 的转换速率
- $V_{CC}$  隔离特性：
  - 如果任何一个  $V_{CC}$  输入低于 100mV，则所有 I/O 输出均禁用且处于高阻抗状态
- $I_{off}$  支持局部断电模式运行
- 兼容 AVC 系列电平转换器
- 闩锁性能超过 100mA，符合 JESD 78 II 类规范
- ESD 保护性能超过 JEDEC JS-001 规范要求
  - 8000V 人体放电模型
  - 1000V 充电器件模型

## 2 应用

- 信息娱乐系统音响主机
- ADAS 融合
- ADAS 前置摄像头
- 混合动力电动汽车和电动汽车电池管理系统
- 远程信息处理控制单元

## 3 说明

符合 AEC-Q100 标准的 SN74AXC4T245-Q1 器件是一款采用两个独立可配置电源轨的四位同相总线收发器。 $V_{CCA}$  和  $V_{CCB}$  电源电压低至 0.65V 时，该器件可正常工作。A 端口用于跟踪  $V_{CCA}$ ，该端口可支持 0.65V 至 3.6V 范围内的任何电源电压。B 端口用于跟踪  $V_{CCB}$ ，该端口也可支持 0.65V 至 3.6V 范围内的任何电源电压。此外，SN74AXC4T245-Q1 还与单电源系统兼容。

SN74AXC4T245-Q1 器件旨在实现数据总线之间的异步通信。根据方向控制输入 ( DIR1 和 2DIR ) 的逻辑电平，此器件将数据从 A 总线传输至 B 总线，或者将数据从 B 总线传输至 A 总线。输出使能输入 ( 1  $\overline{OE}$  和 2  $\overline{OE}$  ) 可用于禁用输出，从而有效隔离总线。SN74AXC4T245-Q1 器件旨在使控制引脚 ( xDIR 和 x  $\overline{OE}$  ) 以  $V_{CCA}$  为基准。

为了确保电平转换器 I/O 在加电或断电期间处于高阻抗状态，x  $\overline{OE}$  引脚应通过一个上拉电阻器连接至  $V_{CCA}$ 。

该器件完全适合使用  $I_{off}$  电流的局部断电应用。当器件断电时， $I_{off}$  保护电路可确保不从输入、输出或偏置到特定电压的组合 I/O 获取多余电流，也不向其提供多余电流。

$V_{CC}$  隔离特性可确保当  $V_{CCA}$  或  $V_{CCB}$  低于 100mV 时，I/O 端口均禁用其输出并进入高阻态。

无干扰电源定序使电源轨能以任何顺序打开或关断，从而提供强大的电源定序性能。

### 器件信息

器件型号	封装 <sup>(1)</sup>	封装尺寸 (标称值)
SN74AXC4T245PW-Q1	TSSOP (16)	5.00mm × 4.40mm
SN74AXC4T245BQB-Q1	WQFN (16)	2.50mm × 3.50mm
SN74AXC4T245WBQB-Q1	WQFN (16)	2.50mm × 3.50mm
SN74AXC4T245RSV-Q1	UQFN (16)	2.60mm × 1.80mm

(1) 如需了解所有可用封装，请参阅数据表末尾的可订购产品附录。

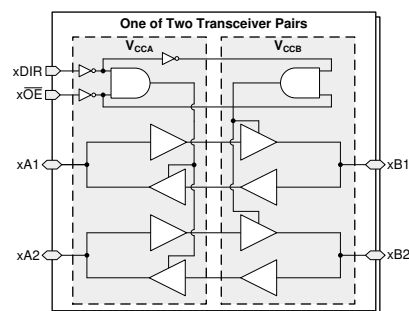

功能方框图

## Table of Contents

<b>1 特性</b> .....	1	7.1 Load Circuit and Voltage Waveforms.....	18
<b>2 应用</b> .....	1	<b>8 Detailed Description</b> .....	20
<b>3 说明</b> .....	1	8.1 Overview.....	20
<b>4 Revision History</b> .....	2	8.2 Functional Block Diagram.....	20
<b>5 Pin Configuration and Functions</b> .....	3	8.3 Feature Description.....	20
<b>6 Specifications</b> .....	4	8.4 Device Functional Modes.....	22
6.1 Absolute Maximum Ratings.....	4	<b>9 Application and Implementation</b> .....	23
6.2 ESD Ratings.....	4	9.1 Application Information.....	23
6.3 Recommended Operating Conditions.....	5	9.2 Typical Application.....	23
6.4 Thermal Information.....	5	<b>10 Power Supply Recommendations</b> .....	25
6.5 Electrical Characteristics.....	6	<b>11 Layout</b> .....	25
6.6 Switching Characteristics, $V_{CCA} = 0.7\text{ V} \pm 0.05\text{ V}$ .....	7	11.1 Layout Guidelines.....	25
6.7 Switching Characteristics, $V_{CCA} = 0.8\text{ V} \pm 0.04\text{ V}$ .....	8	11.2 Layout Example.....	25
6.8 Switching Characteristics, $V_{CCA} = 0.9\text{ V} \pm 0.045\text{ V}$ .....	9	<b>12 Device and Documentation Support</b> .....	26
6.9 Switching Characteristics, $V_{CCA} = 1.2\text{ V} \pm 0.1\text{ V}$ .....	10	12.1 Documentation Support.....	26
6.10 Switching Characteristics, $V_{CCA} = 1.5\text{ V} \pm 0.1\text{ V}$ .....	11	12.2 接收文档更新通知.....	26
6.11 Switching Characteristics, $V_{CCA} = 1.8\text{ V} \pm 0.15\text{ V}$ .....	12	12.3 支持资源.....	26
6.12 Switching Characteristics, $V_{CCA} = 2.5\text{ V} \pm 0.2\text{ V}$ .....	13	12.4 Trademarks.....	26
6.13 Switching Characteristics, $V_{CCA} = 3.3\text{ V} \pm 0.3\text{ V}$ .....	14	12.5 Electrostatic Discharge Caution.....	26
6.14 Operating Characteristics: $T_A = 25^\circ\text{C}$ .....	15	12.6 术语表.....	26
6.15 Typical Characteristics.....	17	<b>13 Mechanical, Packaging, and Orderable Information</b> .....	26
<b>7 Parameter Measurement Information</b> .....	18		

## 4 Revision History

注：以前版本的页码可能与当前版本的页码不同

<b>Changes from Revision D (September 2021) to Revision E (December 2021)</b>	<b>Page</b>
• 将 WBQB 封装的状态从：产品预发布 更改为 “量产” .....	1
<b>Changes from Revision C (March 2021) to Revision D (September 2021)</b>	<b>Page</b>
• 为 APL 添加了 BQB (WQFN) 封装.....	1
<b>Changes from Revision B (July 2020) to Revision C (March 2021)</b>	<b>Page</b>
• 将 BQB (WQFN) 封装选项的状态从 预发布 更改为 量产 .....	1
<b>Changes from Revision A (December 2019) to Revision B (July 2020)</b>	<b>Page</b>
• 更新了整个文档中的表、图和交叉参考的编号格式.....	1
• 向 器件信息 表添加了 BQB (WQFN) 封装选项.....	1
<b>Changes from Revision * (July 2019) to Revision A (December 2019)</b>	<b>Page</b>
• 将 “预告信息” 更改为 “量产数据” .....	1

## 5 Pin Configuration and Functions



图 5-1. PW Package 16-Pin TSSOP Top View



图 5-2. BQB/WBQB Package 16-Pin WQFN Transparent Top View

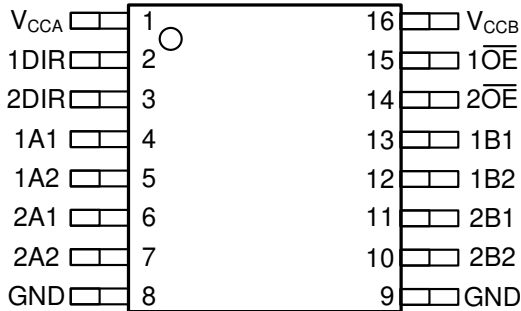

图 5-3. RSV Package 16-Pin UQFN Transparent Top View

表 5-1. Pin Functions

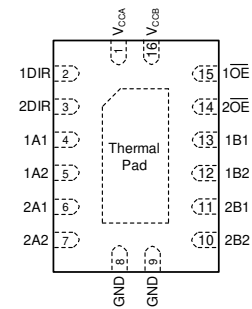
PIN NAME	NO.			TYPE	DESCRIPTION
	PW	RSV	BQB		
1A1	4	6	4	I/O	Input/output 1A1. Referenced to $V_{CCA}$
1A2	5	7	5	I/O	Input/output 1A2. Referenced to $V_{CCA}$
1B1	13	15	13	I/O	Input/output 1B1. Referenced to $V_{CCB}$
1B2	12	14	12	I/O	Input/output 1B2. Referenced to $V_{CCB}$
1DIR	2	4	2	I	Direction-control input for '1' ports. Referenced to $V_{CCA}$
1OE	15	1	15	I	Tri-state output-mode enable. Pull OE high to place '1' outputs in tri-state mode. Referenced to $V_{CCA}$
2A1	6	8	6	I/O	Input/output 2A1. Referenced to $V_{CCA}$
2A2	7	9	7	I/O	Input/output 2A2. Referenced to $V_{CCA}$
2B1	11	13	11	I/O	Input/output 2B1. Referenced to $V_{CCB}$
2B2	10	12	10	I/O	Input/output 2B2. Referenced to $V_{CCB}$
2DIR	3	5	3	I	Direction-control input for '2' ports. Referenced to $V_{CCA}$
2OE	14	16	14	I	Tri-state output-mode enable. Pull OE high to place '2' outputs in tri-state mode. Referenced to $V_{CCA}$
GND	8, 9	10, 11	8, 9	—	Ground
$V_{CCA}$	1	3	1	—	A-port power supply voltage. $0.65\text{ V} \leq V_{CCA} \leq 3.6\text{ V}$
$V_{CCB}$	16	2	16	—	B-port power supply voltage. $0.65\text{ V} \leq V_{CCB} \leq 3.6\text{ V}$

## 6 Specifications

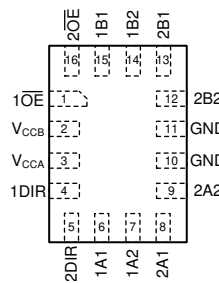
### 6.1 Absolute Maximum Ratings

over operating free-air temperature range (unless otherwise noted)<sup>(1)</sup>

			MIN	MAX	UNIT
V <sub>CCA</sub>	Supply voltage A		- 0.5	4.2	V
V <sub>CCB</sub>	Supply voltage B		- 0.5	4.2	V
V <sub>I</sub>	Input Voltage <sup>(2)</sup>	I/O Ports (A Port)	- 0.5	4.2	V
		I/O Ports (B Port)	- 0.5	4.2	
		Control Inputs	- 0.5	4.2	
V <sub>O</sub>	Voltage applied to any output in the high-impedance or power-off state <sup>(2)</sup>	A Port	- 0.5	4.2	V
		B Port	- 0.5	4.2	
V <sub>O</sub>	Voltage applied to any output in the high or low state <sup>(2) (3)</sup>	A Port	- 0.5 V <sub>CCA</sub> + 0.2	V	
		B Port	- 0.5 V <sub>CCB</sub> + 0.2		
I <sub>IK</sub>	Input clamp current	V <sub>I</sub> < 0	- 50		mA
I <sub>OK</sub>	Output clamp current	V <sub>O</sub> < 0	- 50		mA
I <sub>O</sub>	Continuous output current		- 50	50	mA
	Continuous current through V <sub>CC</sub> or GND		- 100	100	
T <sub>j</sub>	Junction Temperature			150	°C
T <sub>stg</sub>	Storage temperature		- 65	150	°C

- (1) Stresses beyond those listed under *Absolute Maximum Ratings* may cause permanent damage to the device. These are stress ratings only, which do not imply functional operation of the device at these or any other conditions beyond those indicated under *Recommended Operating Conditions*. Exposure to absolute-maximum-rated conditions for extended periods may affect device reliability.
- (2) The input voltage and output negative-voltage ratings may be exceeded if the input and output current ratings are observed.
- (3) The output positive-voltage rating may be exceeded up to 4.2 V maximum if the output current rating is observed.

### 6.2 ESD Ratings

			VALUE	UNIT
V <sub>(ESD)</sub>	Electrostatic discharge	Human body model (HBM), per AEC Q100-002 <sup>(1)</sup>	±8000	V
		Charged device model (CDM), per AEC Q100-011	±1000	

- (1) AEC Q100-002 indicates that HBM stressing shall be in accordance with the ANSI/ESDA/JEDEC JS-001 specification.

### 6.3 Recommended Operating Conditions

over operating free-air temperature range (unless otherwise noted)<sup>(1) (2)</sup>

			MIN	MAX	UNIT
V <sub>CCA</sub>	Supply voltage A		0.65	3.6	V
V <sub>CCB</sub>	Supply voltage B		0.65	3.6	V
V <sub>IH</sub>	High-level input voltage	Data Inputs	V <sub>CCI</sub> = 0.65 V - 0.75 V	V <sub>CCI</sub> × 0.70	V
			V <sub>CCI</sub> = 0.76 V - 1 V	V <sub>CCI</sub> × 0.70	
			V <sub>CCI</sub> = 1.1 V - 1.95 V	V <sub>CCI</sub> × 0.65	
			V <sub>CCI</sub> = 2.3 V - 2.7 V	1.6	
			V <sub>CCI</sub> = 3 V - 3.6 V	2	
		Control Inputs(xDIR, xOE) Referenced to V <sub>CCA</sub>	V <sub>CCA</sub> = 0.65 V - 0.75 V	V <sub>CCA</sub> × 0.70	
			V <sub>CCA</sub> = 0.76 V - 1 V	V <sub>CCA</sub> × 0.70	
			V <sub>CCA</sub> = 1.1 V - 1.95 V	V <sub>CCA</sub> × 0.65	
			V <sub>CCA</sub> = 2.3 V - 2.7 V	1.6	
			V <sub>CCA</sub> = 3 V - 3.6 V	2	
V <sub>IL</sub>	Low-level input voltage	Data Inputs	V <sub>CCI</sub> = 0.65 V - 0.75 V	V <sub>CCI</sub> × 0.30	V
			V <sub>CCI</sub> = 0.76 V - 1 V	V <sub>CCI</sub> × 0.30	
			V <sub>CCI</sub> = 1.1 V - 1.95 V	V <sub>CCI</sub> × 0.35	
			V <sub>CCI</sub> = 2.3 V - 2.7 V	0.7	
			V <sub>CCI</sub> = 3 V - 3.6 V	0.8	
		Control Inputs(xDIR, xOE) Referenced to V <sub>CCA</sub>	V <sub>CCA</sub> = 0.65 V - 0.75 V	V <sub>CCA</sub> × 0.30	
			V <sub>CCA</sub> = 0.76 V - 1 V	V <sub>CCA</sub> × 0.30	
			V <sub>CCA</sub> = 1.1 V - 1.95 V	V <sub>CCA</sub> × 0.35	
			V <sub>CCA</sub> = 2.3 V - 2.7 V	0.7	
			V <sub>CCA</sub> = 3 V - 3.6 V	0.8	
V <sub>I</sub>	Input voltage <sup>(2)</sup>		0	3.6	V
V <sub>O</sub>	Output voltage	Active State	0	V <sub>CCO</sub>	V
		Tri-State	0	3.6	
$\frac{\Delta t}{\Delta V}$ <sup>(2)</sup>	Input transition rate			10	ns/V
T <sub>A</sub>	Operating free-air temperature		- 40	125	°C

(1) V<sub>CCI</sub> is the V<sub>CC</sub> associated with the input port. V<sub>CCO</sub> is the V<sub>CC</sub> associated with the output port.

(2) All unused inputs of the device must be held at VCC or GND to ensure proper device operation. Refer to the TI application report, [Implications of Slow or Floating CMOS Inputs](#).

### 6.4 Thermal Information

THERMAL METRIC <sup>(1)</sup>		SN74AXC4T245-Q1				UNIT
		PW (TSSOP)	RSV (UQFN)	BQB (WQFN)	WBQB (WQFN)	
		16 PINS	16 PINS	16 PINS	16 PINS	
R <sub>θJA</sub>	Junction-to-ambient thermal resistance	126.9	130.1	73.0	72.9	°C/W
R <sub>θJC(top)</sub>	Junction-to-case (top) thermal resistance	49.3	70.3	35.1	69.6	°C/W
R <sub>θJB</sub>	Junction-to-board thermal resistance	74.3	57.4	42.8	41.9	°C/W
ψ <sub>JT</sub>	Junction-to-top characterization parameter	8.1	4.6	4.6	4.6	°C/W
ψ <sub>JB</sub>	Junction-to-board characterization parameter	73.4	55.8	42.8	41.9	°C/W
R <sub>θJC(bottom)</sub>	Junction-to-case (bottom) thermal resistance	NA	NA	10.2	19.9	°C/W

(1) For more information about traditional and new thermal metrics, see the [Semiconductor and IC Package Thermal Metrics](#) application report.

## 6.5 Electrical Characteristics

over operating free-air temperature range (unless otherwise noted) <sup>(1)</sup> <sup>(2)</sup>

PARAMETER	TEST CONDITIONS	$V_{CCA}$	$V_{CCB}$	Operating free-air temperature ( $T_A$ )						UNIT
				- 40°C to 85°C			- 40°C to 125°C			
				MIN	TYP <sup>(4)</sup>	MAX	MIN	TYP <sup>(4)</sup>	MAX	
$V_{OH}$	High-level output voltage	$V_I = V_{IH}$	$I_{OH} = -100 \mu A$	0.7 V - 3.6 V	0.7 V - 3.6 V	$V_{CCO} - 0.1$		$V_{CCO} - 0.1$		V
			$I_{OH} = -50 \mu A$	0.65 V	0.65 V	0.55		0.55		
			$I_{OH} = -200 \mu A$	0.76 V	0.76 V	0.58		0.58		
			$I_{OH} = -500 \mu A$	0.85 V	0.85 V	0.65		0.65		
			$I_{OH} = -3 \text{ mA}$	1.1 V	1.1 V	0.85		0.85		
			$I_{OH} = -6 \text{ mA}$	1.4 V	1.4 V	1.05		1.05		
			$I_{OH} = -8 \text{ mA}$	1.65 V	1.65 V	1.2		1.2		
			$I_{OH} = -9 \text{ mA}$	2.3 V	2.3 V	1.75		1.75		
			$I_{OH} = -12 \text{ mA}$	3 V	3 V	2.3		2.3		
$V_{OL}$	Low-level output voltage	$V_I = V_{IL}$	$I_{OL} = 100 \mu A$	0.7 V - 3.6 V	0.7 V - 3.6 V	0.1		0.1		V
			$I_{OL} = 50 \mu A$	0.65 V	0.65 V	0.1		0.1		
			$I_{OL} = 200 \mu A$	0.76 V	0.76 V	0.18		0.18		
			$I_{OL} = 500 \mu A$	0.85 V	0.85 V	0.2		0.2		
			$I_{OL} = 3 \text{ mA}$	1.1 V	1.1 V	0.25		0.25		
			$I_{OL} = 6 \text{ mA}$	1.4 V	1.4 V	0.35		0.35		
			$I_{OL} = 8 \text{ mA}$	1.65 V	1.65 V	0.45		0.45		
			$I_{OL} = 9 \text{ mA}$	2.3 V	2.3 V	0.55		0.55		
			$I_{OL} = 12 \text{ mA}$	3 V	3 V	0.7		0.7		
$I_I$	Input leakage current	Control inputs (xDIR, xOE): $V_I = V_{CCA}$ or GND	0.65 V - 3.6 V	0.65 V - 3.6 V	- 0.5	0.5	- 1	1	$\mu A$	
		Data Inputs (xAx, xBx): $V_I = V_{CCI}$ or GND	0.65 V - 3.6 V	0.65 V - 3.6 V	- 4	4	- 8	8	$\mu A$	
$I_{off}$	Partial power down current	A or B Port	0 V	0 V - 3.6 V	- 4	4	- 8	8	$\mu A$	
		$V_I$ or $V_O = 0 \text{ V} - 3.6 \text{ V}$	0 V - 3.6 V	0 V	- 4	4	- 8	8		
$I_{OZ}$	Tri-state output current <sup>(3)</sup>	A or B Port $V_I = V_{CCI}$ or GND, $V_O = V_{CCO}$ or GND, $\overline{OE} = V_{IH}$	3.6 V	3.6 V	- 4	4	- 8	8	$\mu A$	
$I_{CCA}$	$V_{CCA}$ supply current	$V_I = V_{CCI}$ or GND	$I_O = 0$	0.65 V - 3.6 V	0.65 V - 3.6 V	13		26		$\mu A$
				0 V	3.6 V	- 2		- 12		
				3.6 V	0 V	8		16		
$I_{CCB}$	$V_{CCB}$ supply current	$V_I = V_{CCI}$ or GND	$I_O = 0$	0.65 V - 3.6 V	0.65 V - 3.6 V	13		26		$\mu A$
				0 V	3.6 V	8		16		
				3.6 V	0 V	- 2		- 12		
$I_{CCA} + I_{CCB}$	Combined supply current	$V_I = V_{CCI}$ or GND	$I_O = 0$	0.65 V - 3.6 V	0.65 V - 3.6 V	20		40		$\mu A$
$C_i$	Control input capacitance	$V_I = 3.3 \text{ V}$ or GND	3.3 V	3.3 V	4.5		4.5		pF	
$C_{io}$	Data I/O capacitance	$\overline{OE} = V_{CCA}$ , $V_O = 1.65 \text{ V DC} + 1 \text{ MHz} - 16 \text{ dBm}$ sine wave	3.3 V	3.3 V	6.6		6.6		pF	

- (1)  $V_{CCI}$  is the  $V_{CC}$  associated with the input port.
- (2)  $V_{CCO}$  is the  $V_{CC}$  associated with the output port.
- (3) For I/O ports, the parameter  $I_{OZ}$  includes the input leakage current.
- (4) All typical data is taken at 25°C.

## 6.6 Switching Characteristics, $V_{CCA} = 0.7 \text{ V} \pm 0.05 \text{ V}$

See [Figure 1](#) and [Table 1](#) for test circuit and loading. See [Figure 2](#), [Figure 3](#), and [Figure 4](#) for measurement waveforms.

PARAMETER	FROM	TO	Test Conditions	B-Port Supply Voltage ( $V_{CCB}$ )														UNIT			
				0.7 ± 0.05 V		0.8 ± 0.04 V		0.9 ± 0.045 V		1.2 ± 0.1 V		1.5 ± 0.1 V		1.8 ± 0.15 V		2.5 ± 0.2 V			3.3 ± 0.3 V		
				MIN	MAX	MIN	MAX	MIN	MAX	MIN	MAX	MIN	MAX	MIN	MAX	MIN	MAX		MIN	MAX	
$t_{pd}$	Propagation delay	A	B	- 40°C to 85°C	0.5	155	0.5	108	0.5	76	0.5	40	0.5	37	0.5	40	0.5	67	0.5	185	ns
				- 40°C to 125°C	0.5	155	0.5	108	0.5	76	0.5	40	0.5	37	0.5	40	0.5	67	0.5	185	
	B	A	- 40°C to 85°C	0.5	156	0.5	128	0.5	106	0.5	55	0.5	21	0.5	15	0.5	11	0.5	10		
			- 40°C to 125°C	0.5	156	0.5	128	0.5	106	0.5	55	0.5	21	0.5	15	0.5	11	0.5	10		
$t_{dis}$	Disable time	$\overline{OE}$	A	- 40°C to 85°C	0.5	156	0.5	156	0.5	156	0.5	156	0.5	156	0.5	156	0.5	156	0.5	156	ns
				- 40°C to 125°C	0.5	156	0.5	156	0.5	156	0.5	156	0.5	156	0.5	156	0.5	156	0.5	156	
		$\overline{OE}$	B	- 40°C to 85°C	0.5	154	0.5	121	0.5	101	0.5	55	0.5	54	0.5	56	0.5	65	0.5	125	
				- 40°C to 125°C	0.5	154	0.5	121	0.5	101	0.5	55	0.5	54	0.5	56	0.5	65	0.5	125	
$t_{en}$	Enable time	$\overline{OE}$	A	- 40°C to 85°C	0.5	238	0.5	238	0.5	238	0.5	238	0.5	238	0.5	238	0.5	238	0.5	238	ns
				- 40°C to 125°C	0.5	238	0.5	238	0.5	238	0.5	238	0.5	238	0.5	238	0.5	238	0.5	238	
		$\overline{OE}$	B	- 40°C to 85°C	0.5	286	0.5	194	0.5	146	0.5	94	0.5	76	0.5	70	0.5	69	0.5	146	
				- 40°C to 125°C	0.5	286	0.5	194	0.5	146	0.5	94	0.5	76	0.5	70	0.5	69	0.5	146	

## 6.7 Switching Characteristics, $V_{CCA} = 0.8 \text{ V} \pm 0.04 \text{ V}$

See [Figure 1](#) and [Table 1](#) for test circuit and loading. See [Figure 2](#), [Figure 3](#), and [Figure 4](#) for measurement waveforms.

PARAMETER	FROM	TO	Test Conditions	B-Port Supply Voltage ( $V_{CCB}$ )																UNIT	
				0.7 ± 0.05 V		0.8 ± 0.04 V		0.9 ± 0.045 V		1.2 ± 0.1 V		1.5 ± 0.1 V		1.8 ± 0.15 V		2.5 ± 0.2 V		3.3 ± 0.3 V			
				MIN	MAX	MIN	MAX	MIN	MAX	MIN	MAX	MIN	MAX	MIN	MAX	MIN	MAX	MIN	MAX		
$t_{pd}$	Propagation delay	A	B	- 40°C to 85°C	0.5	128	0.5	88	0.5	63	0.5	29	0.5	24	0.5	23	0.5	24	0.5	34	ns
				- 40°C to 125°C	0.5	128	0.5	88	0.5	63	0.5	29	0.5	24	0.5	23	0.5	24	0.5	34	
	B	A	- 40°C to 85°C	0.5	108	0.5	88	0.5	70	0.5	38	0.5	21	0.5	15	0.5	11	0.5	10		
			- 40°C to 125°C	0.5	108	0.5	88	0.5	70	0.5	38	0.5	21	0.5	15	0.5	11	0.5	10		
$t_{dis}$	Disable time	$\overline{OE}$	A	- 40°C to 85°C	0.5	103	0.5	103	0.5	103	0.5	103	0.5	103	0.5	103	0.5	103	0.5	103	ns
				- 40°C to 125°C	0.5	103	0.5	103	0.5	103	0.5	103	0.5	103	0.5	103	0.5	103	0.5	103	
		$\overline{OE}$	B	- 40°C to 85°C	0.5	143	0.5	110	0.5	90	0.5	42	0.5	36	0.5	36	0.5	37	0.5	47	
				- 40°C to 125°C	0.5	143	0.5	110	0.5	90	0.5	42	0.5	36	0.5	36	0.5	37	0.5	47	
$t_{en}$	Enable time	$\overline{OE}$	A	- 40°C to 85°C	0.5	143	0.5	143	0.5	143	0.5	143	0.5	143	0.5	143	0.5	143	0.5	143	ns
				- 40°C to 125°C	0.5	143	0.5	143	0.5	143	0.5	143	0.5	143	0.5	143	0.5	143	0.5	143	
		$\overline{OE}$	B	- 40°C to 85°C	0.5	243	0.5	172	0.5	129	0.5	79	0.5	60	0.5	54	0.5	48	0.5	53	
				- 40°C to 125°C	0.5	243	0.5	172	0.5	129	0.5	79	0.5	60	0.5	54	0.5	48	0.5	53	

## 6.8 Switching Characteristics, $V_{CCA} = 0.9 \text{ V} \pm 0.045 \text{ V}$

See [Figure 1](#) and [Table 1](#) for test circuit and loading. See [Figure 2](#), [Figure 3](#), and [Figure 4](#) for measurement waveforms.

PARAMETER	FROM	TO	Test Conditions	B-Port Supply Voltage ( $V_{CCB}$ )														UNIT			
				0.7 ± 0.05 V		0.8 ± 0.04 V		0.9 ± 0.045 V		1.2 ± 0.1 V		1.5 ± 0.1 V		1.8 ± 0.15 V		2.5 ± 0.2 V			3.3 ± 0.3 V		
				MIN	MAX	MIN	MAX	MIN	MAX	MIN	MAX	MIN	MAX	MIN	MAX	MIN	MAX		MIN	MAX	
$t_{pd}$	Propagation delay	A	B	- 40°C to 85°C	0.5	106	0.5	70	0.5	53	0.5	24	0.5	18	0.5	17	0.5	16	0.5	19	ns
				- 40°C to 125°C	0.5	106	0.5	70	0.5	53	0.5	24	0.5	18	0.5	17	0.5	16	0.5	19	
		B	A	- 40°C to 85°C	0.5	76	0.5	63	0.5	53	0.5	27	0.5	18	0.5	13	0.5	10	0.5	9	
				- 40°C to 125°C	0.5	76	0.5	63	0.5	53	0.5	27	0.5	18	0.5	13	0.5	10	0.5	9	
$t_{dis}$	Disable time	$\overline{OE}$	A	- 40°C to 85°C	0.5	81	0.5	81	0.5	81	0.5	81	0.5	81	0.5	81	0.5	81	0.5	81	ns
				- 40°C to 125°C	0.5	81	0.5	81	0.5	81	0.5	81	0.5	81	0.5	81	0.5	81	0.5	81	
		$\overline{OE}$	B	- 40°C to 85°C	0.5	138	0.5	105	0.5	84	0.5	37	0.5	30	0.5	28	0.5	26	0.5	30	
				- 40°C to 125°C	0.5	138	0.5	105	0.5	84	0.5	37	0.5	30	0.5	28	0.5	26	0.5	30	
$t_{en}$	Enable time	$\overline{OE}$	A	- 40°C to 85°C	0.5	95	0.5	95	0.5	95	0.5	95	0.5	95	0.5	95	0.5	95	0.5	95	ns
				- 40°C to 125°C	0.5	95	0.5	95	0.5	95	0.5	95	0.5	95	0.5	95	0.5	95	0.5	95	
		$\overline{OE}$	B	- 40°C to 85°C	0.5	222	0.5	148	0.5	116	0.5	71	0.5	52	0.5	46	0.5	39	0.5	39	
				- 40°C to 125°C	0.5	222	0.5	148	0.5	116	0.5	71	0.5	52	0.5	46	0.5	39	0.5	39	

## 6.9 Switching Characteristics, $V_{CCA} = 1.2 \text{ V} \pm 0.1 \text{ V}$

See Figure 1 and Table 1 for test circuit and loading. See Figure 2, Figure 3, and Figure 4 for measurement waveforms.

PARAMETER	FROM	TO	Test Conditions	B-Port Supply Voltage ( $V_{CCB}$ )												UNIT					
				0.7 ± 0.05 V		0.8 ± 0.04 V		0.9 ± 0.045 V		1.2 ± 0.1 V		1.5 ± 0.1 V		1.8 ± 0.15 V			2.5 ± 0.2 V		3.3 ± 0.3 V		
				MIN	MAX	MIN	MAX	MIN	MAX	MIN	MAX	MIN	MAX	MIN	MAX		MIN	MAX	MIN	MAX	
$t_{pd}$	Propagation delay	A	B	- 40°C to 85°C	0.5	55	0.5	37	0.5	27	0.5	15	0.5	11	0.5	10	0.5	8	0.5	9	ns
				- 40°C to 125°C	0.5	55	0.5	37	0.5	27	0.5	15	0.5	11	0.5	10	0.5	8	0.5	9	
		B	A	- 40°C to 85°C	0.5	41	0.5	29	0.5	24	0.5	15	0.5	10	0.5	9	0.5	7	0.5	6	
				- 40°C to 125°C	0.5	41	0.5	29	0.5	24	0.5	15	0.5	10	0.5	9	0.5	7	0.5	6	
$t_{dis}$	Disable time	$\overline{OE}$	A	- 40°C to 85°C	0.5	30	0.5	30	0.5	30	0.5	30	0.5	30	0.5	30	0.5	30	0.5	30	ns
				- 40°C to 125°C	0.5	30	0.5	30	0.5	30	0.5	30	0.5	30	0.5	30	0.5	30	0.5	30	
		$\overline{OE}$	B	- 40°C to 85°C	0.5	132	0.5	99	0.5	79	0.5	31	0.5	24	0.5	21	0.5	18	0.5	18	
				- 40°C to 125°C	0.5	132	0.5	99	0.5	79	0.5	31	0.5	24	0.5	21	0.5	18	0.5	18	
$t_{en}$	Enable time	$\overline{OE}$	A	- 40°C to 85°C	0.5	45	0.5	45	0.5	45	0.5	45	0.5	45	0.5	45	0.5	45	0.5	45	ns
				- 40°C to 125°C	0.5	45	0.5	45	0.5	45	0.5	45	0.5	45	0.5	45	0.5	45	0.5	45	
		$\overline{OE}$	B	- 40°C to 85°C	0.5	164	0.5	108	0.5	79	0.5	58	0.5	41	0.5	35	0.5	27	0.5	24	
				- 40°C to 125°C	0.5	164	0.5	108	0.5	79	0.5	58	0.5	41	0.5	35	0.5	27	0.5	24	

## 6.10 Switching Characteristics, $V_{CCA} = 1.5 \text{ V} \pm 0.1 \text{ V}$

See [Figure 1](#) and [Table 1](#) for test circuit and loading. See [Figure 2](#), [Figure 3](#), and [Figure 4](#) for measurement waveforms.

PARAMETER	FROM	TO	Test Conditions	B-Port Supply Voltage ( $V_{CCB}$ )														UNIT			
				0.7 ± 0.05 V		0.8 ± 0.04 V		0.9 ± 0.045 V		1.2 ± 0.1 V		1.5 ± 0.1 V		1.8 ± 0.15 V		2.5 ± 0.2 V			3.3 ± 0.3 V		
				MIN	MAX	MIN	MAX	MIN	MAX	MIN	MAX	MIN	MAX	MIN	MAX	MIN	MAX		MIN	MAX	
$t_{pd}$	Propagation delay	A	B	- 40°C to 85°C	0.5	21	0.5	21	0.5	18	0.5	11	0.5	9	0.5	8	0.5	7	0.5	6	ns
				- 40°C to 125°C	0.5	21	0.5	21	0.5	18	0.5	11	0.5	9	0.5	8	0.5	7	0.5	6	
	B	A	- 40°C to 85°C	0.5	37	0.5	24	0.5	18	0.5	11	0.5	9	0.5	8	0.5	5	0.5	5		
			- 40°C to 125°C	0.5	37	0.5	24	0.5	18	0.5	11	0.5	9	0.5	8	0.5	5	0.5	5		
$t_{dis}$	Disable time	$\overline{OE}$	A	- 40°C to 85°C	0.5	21	0.5	21	0.5	21	0.5	21	0.5	21	0.5	21	0.5	21	0.5	21	ns
				- 40°C to 125°C	0.5	21	0.5	21	0.5	21	0.5	21	0.5	21	0.5	21	0.5	21	0.5	21	
		$\overline{OE}$	B	- 40°C to 85°C	0.5	131	0.5	97	0.5	77	0.5	29	0.5	21	0.5	19	0.5	15	0.5	15	
				- 40°C to 125°C	0.5	131	0.5	97	0.5	77	0.5	29	0.5	21	0.5	19	0.5	15	0.5	15	
$t_{en}$	Enable time	$\overline{OE}$	A	- 40°C to 85°C	0.5	26	0.5	26	0.5	26	0.5	26	0.5	26	0.5	26	0.5	26	0.5	26	ns
				- 40°C to 125°C	0.5	26	0.5	26	0.5	26	0.5	26	0.5	26	0.5	26	0.5	26	0.5	26	
		$\overline{OE}$	B	- 40°C to 85°C	0.5	109	0.5	84	0.5	68	0.5	47	0.5	35	0.5	29	0.5	22	0.5	20	
				- 40°C to 125°C	0.5	109	0.5	84	0.5	68	0.5	47	0.5	35	0.5	29	0.5	22	0.5	20	

## 6.11 Switching Characteristics, $V_{CCA} = 1.8 \text{ V} \pm 0.15 \text{ V}$

See [Figure 1](#) and [Table 1](#) for test circuit and loading. See [Figure 2](#), [Figure 3](#), and [Figure 4](#) for measurement waveforms.

PARAMETER	FROM	TO	Test Conditions	B-Port Supply Voltage ( $V_{CCB}$ )												UNIT					
				0.7 ± 0.05 V		0.8 ± 0.04 V		0.9 ± 0.045 V		1.2 ± 0.1 V		1.5 ± 0.1 V		1.8 ± 0.15 V			2.5 ± 0.2 V		3.3 ± 0.3 V		
				MIN	MAX	MIN	MAX	MIN	MAX	MIN	MAX	MIN	MAX	MIN	MAX		MIN	MAX	MIN	MAX	
$t_{pd}$	Propagation delay	A	B	-40°C to 85°C	0.5	15	0.5	15	0.5	13	0.5	9	0.5	8	0.5	7	0.5	6	0.5	6	ns
				-40°C to 125°C	0.5	15	0.5	15	0.5	13	0.5	9	0.5	8	0.5	7	0.5	6	0.5	6	
	B	A	-40°C to 85°C	0.5	40	0.5	23	0.5	17	0.5	10	0.5	8	0.5	7	0.5	5	0.5	4		
			-40°C to 125°C	0.5	40	0.5	23	0.5	17	0.5	10	0.5	8	0.5	7	0.5	5	0.5	4		
$t_{dis}$	Disable time	$\overline{OE}$	A	-40°C to 85°C	0.5	18	0.5	18	0.5	18	0.5	18	0.5	18	0.5	18	0.5	18	0.5	18	ns
				-40°C to 125°C	0.5	18	0.5	18	0.5	18	0.5	18	0.5	18	0.5	18	0.5	18	0.5	18	
		$\overline{OE}$	B	-40°C to 85°C	0.5	130	0.5	96	0.5	76	0.5	28	0.5	21	0.5	18	0.5	15	0.5	14	
				-40°C to 125°C	0.5	130	0.5	96	0.5	76	0.5	28	0.5	21	0.5	18	0.5	15	0.5	14	
$t_{en}$	Enable time	$\overline{OE}$	A	-40°C to 85°C	0.5	20	0.5	20	0.5	20	0.5	20	0.5	20	0.5	20	0.5	20	0.5	20	ns
				-40°C to 125°C	0.5	20	0.5	20	0.5	20	0.5	20	0.5	20	0.5	20	0.5	20	0.5	20	
		$\overline{OE}$	B	-40°C to 85°C	0.5	102	0.5	75	0.5	62	0.5	41	0.5	32	0.5	27	0.5	20	0.5	18	
				-40°C to 125°C	0.5	102	0.5	75	0.5	62	0.5	41	0.5	32	0.5	27	0.5	20	0.5	18	

## 6.12 Switching Characteristics, $V_{CCA} = 2.5 \text{ V} \pm 0.2 \text{ V}$

See [Figure 1](#) and [Table 1](#) for test circuit and loading. See [Figure 2](#), [Figure 3](#), and [Figure 4](#) for measurement waveforms.

PARAMETER	FROM	TO	Test Conditions	B-Port Supply Voltage ( $V_{CCB}$ )														UNIT			
				0.7 ± 0.05 V		0.8 ± 0.04 V		0.9 ± 0.045 V		1.2 ± 0.1 V		1.5 ± 0.1 V		1.8 ± 0.15 V		2.5 ± 0.2 V			3.3 ± 0.3 V		
				MIN	MAX	MIN	MAX	MIN	MAX	MIN	MAX	MIN	MAX	MIN	MAX	MIN	MAX		MIN	MAX	
$t_{pd}$	Propagation delay	A	B	- 40°C to 85°C	0.5	11	0.5	11	0.5	10	0.5	7	0.5	5	0.5	5	0.5	5	0.5	5	ns
				- 40°C to 125°C	0.5	11	0.5	11	0.5	11	0.5	7	0.5	5	0.5	5	0.5	5	0.5	5	
	B	A	- 40°C to 85°C	0.5	67	0.5	24	0.5	16	0.5	8	0.5	7	0.5	6	0.5	5	0.5	4		
			- 40°C to 125°C	0.5	67	0.5	24	0.5	16	0.5	8	0.5	7	0.5	6	0.5	5	0.5	4		
$t_{dis}$	Disable time	$\overline{OE}$	A	- 40°C to 85°C	0.5	13	0.5	13	0.5	13	0.5	13	0.5	13	0.5	13	0.5	13	0.5	13	ns
				- 40°C to 125°C	0.5	13	0.5	13	0.5	13	0.5	13	0.5	13	0.5	13	0.5	13	0.5	13	
		$\overline{OE}$	B	- 40°C to 85°C	0.5	128	0.5	95	0.5	76	0.5	27	0.5	20	0.5	17	0.5	13	0.5	13	
				- 40°C to 125°C	0.5	128	0.5	95	0.5	76	0.5	27	0.5	20	0.5	17	0.5	13	0.5	13	
$t_{en}$	Enable time	$\overline{OE}$	A	- 40°C to 85°C	0.5	13	0.5	13	0.5	13	0.5	13	0.5	13	0.5	13	0.5	13	0.5	13	ns
				- 40°C to 125°C	0.5	13	0.5	13	0.5	13	0.5	13	0.5	13	0.5	13	0.5	13	0.5	13	
		$\overline{OE}$	B	- 40°C to 85°C	0.5	120	0.5	70	0.5	56	0.5	36	0.5	26	0.5	22	0.5	18	0.5	16	
				- 40°C to 125°C	0.5	120	0.5	70	0.5	56	0.5	36	0.5	26	0.5	22	0.5	18	0.5	16	

### 6.13 Switching Characteristics, $V_{CCA} = 3.3 \text{ V} \pm 0.3 \text{ V}$

See [Figure 1](#) and [Table 1](#) for test circuit and loading. See [Figure 2](#), [Figure 3](#), and [Figure 4](#) for measurement waveforms.

PARAMETER	FROM	TO	Test Conditions	B-Port Supply Voltage ( $V_{CCB}$ )														UNIT				
				0.7 ± 0.05 V		0.8 ± 0.04 V		0.9 ± 0.045 V		1.2 ± 0.1 V		1.5 ± 0.1 V		1.8 ± 0.15 V		2.5 ± 0.2 V			3.3 ± 0.3 V			
				MIN	MAX	MIN	MAX	MIN	MAX	MIN	MAX	MIN	MAX	MIN	MAX	MIN	MAX		MIN	MAX		
$t_{pd}$	Propagation delay	A	B	- 40°C to 85°C	0.5	10	0.5	10	0.5	9	0.5	6	0.5	5	0.5	4	0.5	4	0.5	4	ns	
				- 40°C to 125°C	0.5	10	0.5	10	0.5	9	0.5	6	0.5	5	0.5	4	0.5	4	0.5	4		
		B	A	- 40°C to 85°C	0.5	185	0.5	34	0.5	19	0.5	9	0.5	6	0.5	6	0.5	5	0.5	4		ns
				- 40°C to 125°C	0.5	185	0.5	34	0.5	19	0.5	9	0.5	6	0.5	6	0.5	5	0.5	4		
$t_{dis}$	Disable time	$\overline{OE}$	A	- 40°C to 85°C	0.5	12	0.5	12	0.5	12	0.5	12	0.5	12	0.5	12	0.5	12	0.5	12	ns	
				- 40°C to 125°C	0.5	12	0.5	12	0.5	12	0.5	12	0.5	12	0.5	12	0.5	12	0.5	12		
		$\overline{OE}$	B	- 40°C to 85°C	0.5	141	0.5	95	0.5	75	0.5	27	0.5	19	0.5	17	0.5	13	0.5	12		ns
				- 40°C to 125°C	0.5	141	0.5	95	0.5	75	0.5	27	0.5	19	0.5	17	0.5	13	0.5	12		
$t_{en}$	Enable time	$\overline{OE}$	A	- 40°C to 85°C	0.5	11	0.5	11	0.5	11	0.5	11	0.5	11	0.5	11	0.5	11	0.5	11	ns	
				- 40°C to 125°C	0.5	11	0.5	11	0.5	11	0.5	11	0.5	11	0.5	11	0.5	11	0.5	11		
		$\overline{OE}$	B	- 40°C to 85°C	0.5	189	0.5	82	0.5	59	0.5	35	0.5	24	0.5	20	0.5	16	0.5	14		ns
				- 40°C to 125°C	0.5	189	0.5	82	0.5	59	0.5	35	0.5	24	0.5	20	0.5	16	0.5	14		

**6.14 Operating Characteristics: T<sub>A</sub> = 25°C**

PARAMETER		TEST CONDITIONS	V <sub>CCA</sub>	V <sub>CCB</sub>	MIN	TYP	MAX	UNIT
C <sub>pdA</sub>	Power Dissipation Capacitance per transceiver (A to B: outputs enabled)	CL = 0, RL = Open f = 1 MHz, tr = tf = 1 ns	0.7 V	0.7 V		2.2		pF
			0.8 V	0.8 V		2.1		
			0.9 V	0.9 V		2.1		
			1.2 V	1.2 V		2.1		
			1.5 V	1.5 V		2.0		
			1.8 V	1.8 V		2.0		
			2.5 V	2.5 V		2.1		
			3.3 V	3.3 V		2.3		
	Power Dissipation Capacitance per transceiver (A to B: outputs disabled)	CL = 0, RL = Open f = 1 MHz, tr = tf = 1 ns	0.7 V	0.7 V		1.5		pF
			0.8 V	0.8 V		1.5		
			0.9 V	0.9 V		1.5		
			1.2 V	1.2 V		1.4		
			1.5 V	1.5 V		1.4		
			1.8 V	1.8 V		1.4		
			2.5 V	2.5 V		1.4		
			3.3 V	3.3 V		1.6		
	Power Dissipation Capacitance per transceiver (B to A: outputs enabled)	CL = 0, RL = Open f = 1 MHz, tr = tf = 1 ns	0.7 V	0.7 V		12.1		pF
			0.8 V	0.8 V		12.1		
			0.9 V	0.9 V		12.1		
			1.2 V	1.2 V		12.4		
			1.5 V	1.5 V		13.0		
			1.8 V	1.8 V		14.2		
			2.5 V	2.5 V		17.4		
			3.3 V	3.3 V		20.1		
	Power Dissipation Capacitance per transceiver (B to A: outputs disabled)	CL = 0, RL = Open f = 1 MHz, tr = tf = 1 ns	0.7 V	0.7 V		1.1		pF
			0.8 V	0.8 V		1.1		
			0.9 V	0.9 V		1.1		
			1.2 V	1.2 V		1.1		
1.5 V			1.5 V		1.1			
1.8 V			1.8 V		1.1			
2.5 V			2.5 V		1.1			
3.3 V			3.3 V		1.1			

**6.14 Operating Characteristics: T<sub>A</sub> = 25°C (continued)**

PARAMETER		TEST CONDITIONS	V <sub>CCA</sub>	V <sub>CCB</sub>	MIN	TYP	MAX	UNIT
C <sub>pdB</sub>	Power Dissipation Capacitance per transceiver (A to B: outputs enabled)	CL = 0, RL = Open f = 1 MHz, tr = tf = 1 ns	0.7 V	0.7 V		12.1		pF
			0.8 V	0.8 V		12.1		
			0.9 V	0.9 V		12.1		
			1.2 V	1.2 V		12.4		
			1.5 V	1.5 V		12.9		
			1.8 V	1.8 V		14.1		
			2.5 V	2.5 V		17.2		
			3.3 V	3.3 V		20.1		
	Power Dissipation Capacitance per transceiver (A to B: outputs disabled)	CL = 0, RL = Open f = 1 MHz, tr = tf = 1 ns	0.7 V	0.7 V		1.1		pF
			0.8 V	0.8 V		1.1		
			0.9 V	0.9 V		1.1		
			1.2 V	1.2 V		1.1		
			1.5 V	1.5 V		1.1		
			1.8 V	1.8 V		1.1		
			2.5 V	2.5 V		1.1		
			3.3 V	3.3 V		1.1		
	Power Dissipation Capacitance per transceiver (B to A: outputs enabled)	CL = 0, RL = Open f = 1 MHz, tr = tf = 1 ns	0.7 V	0.7 V		1.2		pF
			0.8 V	0.8 V		1.8		
			0.9 V	0.9 V		1.8		
			1.2 V	1.2 V		1.7		
			1.5 V	1.5 V		1.7		
			1.8 V	1.8 V		1.7		
			2.5 V	2.5 V		2		
			3.3 V	3.3 V		2.5		
	Power Dissipation Capacitance per transceiver (B to A: outputs disabled)	CL = 0, RL = Open f = 1 MHz, tr = tf = 1 ns	0.7 V	0.7 V		1.1		pF
			0.8 V	0.8 V		1.8		
			0.9 V	0.9 V		1.8		
			1.2 V	1.2 V		1.7		
			1.5 V	1.5 V		1.7		
			1.8 V	1.8 V		1.7		
			2.5 V	2.5 V		2		
			3.3 V	3.3 V		2.1		

### 6.15 Typical Characteristics



图 6-1. Typical ( $T_A=25^\circ\text{C}$ ) Output High Voltage ( $V_{OH}$ ) vs Source Current ( $I_{OH}$ )



图 6-2. Typical ( $T_A=25^\circ\text{C}$ ) Output High Voltage ( $V_{OH}$ ) vs Source Current ( $I_{OH}$ )

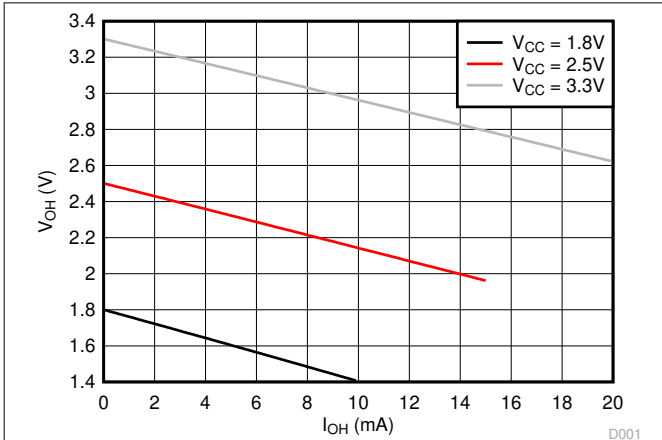

图 6-3. Typical ( $T_A=25^\circ\text{C}$ ) Output Low Voltage ( $V_{OL}$ ) vs Sink Current ( $I_{OL}$ )

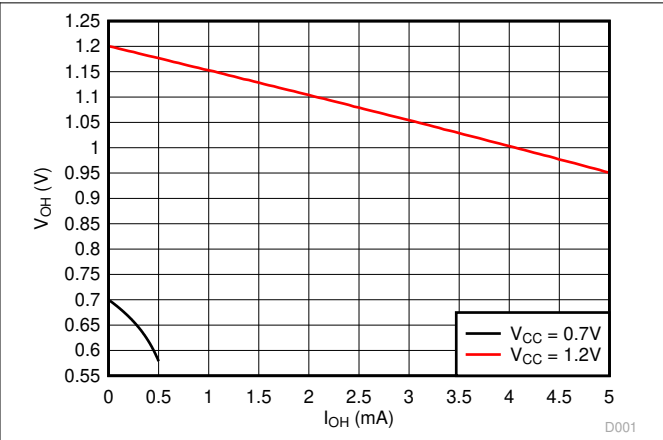

图 6-4. Typical ( $T_A=25^\circ\text{C}$ ) Output Low Voltage ( $V_{OL}$ ) vs Sink Current ( $I_{OL}$ )

## 7 Parameter Measurement Information

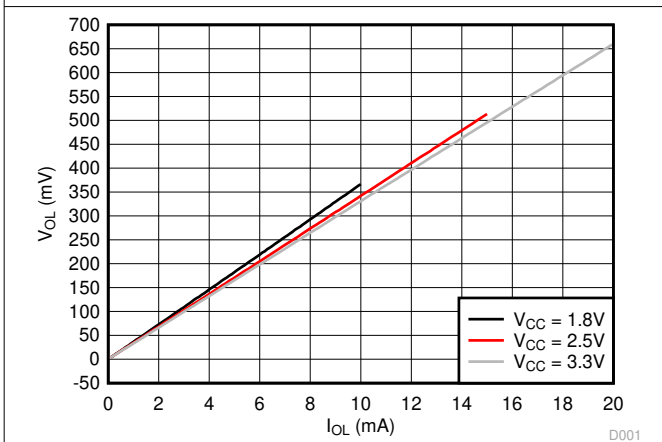
### 7.1 Load Circuit and Voltage Waveforms

Unless otherwise noted, all input pulses are supplied by generators having the following characteristics:

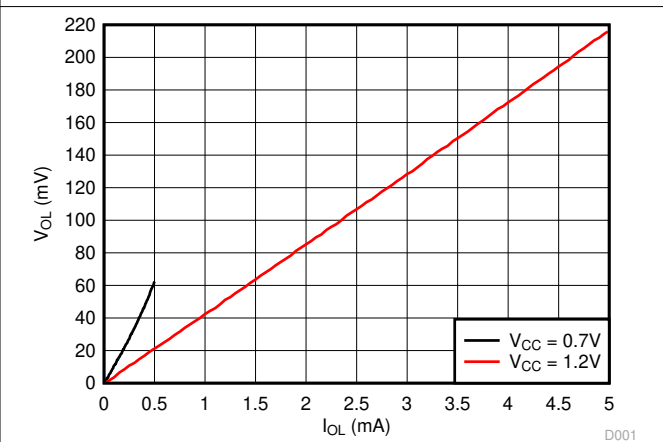
- $f = 1 \text{ MHz}$
- $Z_O = 50 \ \Omega$
- $dv/dt \leq 1 \text{ ns/V}$

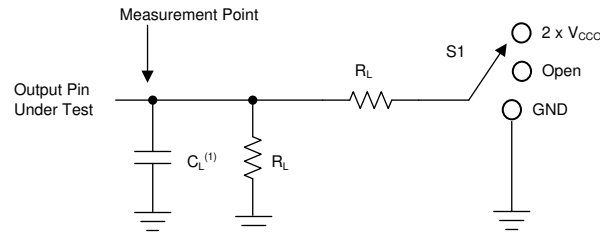

A.  $C_L$  includes probe and jig capacitance.

图 7-1. Load Circuit

表 7-1. Load Circuit Conditions

Parameter	$V_{CCO}$	$R_L$	$C_L$	$S_1$	$V_{TP}$
$\frac{\Delta t}{\Delta V}$ Input transition rise or fall rate	0.65 V - 3.6 V	1 M $\Omega$	15 pF	Open	N/A
$t_{pd}$ Propagation (delay) time	1.1 V - 3.6 V	2 k $\Omega$	15 pF	Open	N/A
	0.65 V - 0.95 V	20 k $\Omega$	15 pF	Open	N/A
$t_{en}, t_{dis}$ Enable time, disable time	3 V - 3.6 V	2 k $\Omega$	15 pF	$2 \times V_{CCO}$	0.3 V
	1.65 V - 2.7 V	2 k $\Omega$	15 pF	$2 \times V_{CCO}$	0.15 V
	1.1 V - 1.6 V	2 k $\Omega$	15 pF	$2 \times V_{CCO}$	0.1 V
	0.65 V - 0.95 V	20 k $\Omega$	15 pF	$2 \times V_{CCO}$	0.1 V
$t_{en}, t_{dis}$ Enable time, disable time	3 V - 3.6 V	2 k $\Omega$	15 pF	GND	0.3 V
	1.65 V - 2.7 V	2 k $\Omega$	15 pF	GND	0.15 V
	1.1 V - 1.6 V	2 k $\Omega$	15 pF	GND	0.1 V
	0.65 V - 0.95 V	20 k $\Omega$	15 pF	GND	0.1 V



图 7-3. Input Transition Rise or Fall Rate



- A. Output waveform on the condition that input is driven to a valid Logic Low.
- B. Output waveform on the condition that input is driven to a valid Logic High.
- C.  $V_{CCO}$  is the supply pin associated with the output port.
- D.  $V_{OH}$  and  $V_{OL}$  are typical output voltage levels with specified  $R_L$ ,  $C_L$ , and  $S_1$ .

**图 7-4. Enable Time And Disable Time**

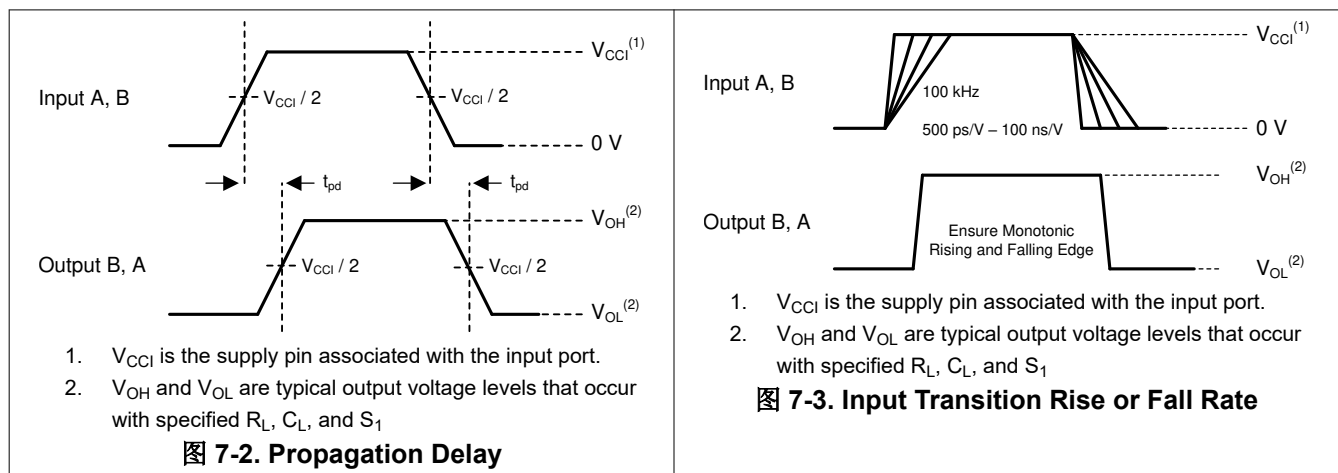
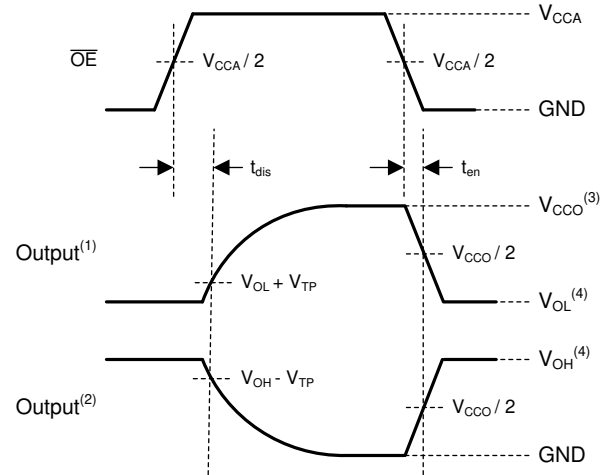
## 8 Detailed Description

### 8.1 Overview

The SN74AXC4T245-Q1 AEC-Q100 qualified device is a 4-bit, dual-supply noninverting bidirectional voltage level translation device. Ax pins and control pins (1DIR, 2DIR, 1  $\overline{OE}$ , and 2  $\overline{OE}$ ) are referenced to  $V_{CCA}$  logic levels, and Bx pins are referenced to  $V_{CCB}$  logic levels. The A port is able to accept I/O voltages ranging from 0.65 V to 3.6 V, while the B port can accept I/O voltages from 0.65 V to 3.6 V. A high on DIR allows data transmission from A to B and a low on DIR allows data transmission from B to A when  $\overline{OE}$  is set to low. When  $\overline{OE}$  is set to high, both Ax and Bx pins are in the high-impedance state. See [Device Functional Modes](#) for a summary of the operation of the control logic.

### 8.2 Functional Block Diagram

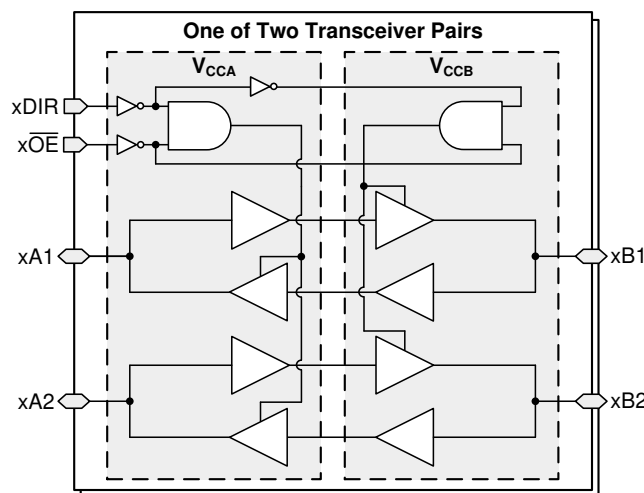

### 8.3 Feature Description

#### 8.3.1 Standard CMOS Inputs

Standard CMOS inputs are high impedance and are typically modeled as a resistor in parallel with the input capacitance given in the [Electrical Characteristics](#). The worst case resistance is calculated with the maximum input voltage, given in the [Absolute Maximum Ratings](#), and the maximum input leakage current, given in the [Electrical Characteristics](#), using ohm's law ( $R = V \div I$ ).

Signals applied to the inputs need to have fast edge rates, as defined by  $\Delta t / \Delta v$  in [Recommended Operating Conditions](#) to avoid excessive current consumption and oscillations. If a slow or noisy input signal is required, a device with a Schmitt-trigger input should be used to condition the input signal prior to the standard CMOS input.

#### 8.3.2 Balanced High-Drive CMOS Push-Pull Outputs

A balanced output allows the device to sink and source similar currents. The high drive capability of this device creates fast edges into light loads so routing and load conditions should be considered to prevent ringing. Additionally, the outputs of this device are capable of driving larger currents than the device can sustain without being damaged. The electrical and thermal limits defined in the [Absolute Maximum Ratings](#) must be followed at all times.

#### 8.3.3 Partial Power Down ( $I_{off}$ )

The inputs and outputs for this device enter a high-impedance state when the device is powered down, inhibiting current backflow into the device. The maximum leakage into or out of any input or output pin on the device is specified by  $I_{off}$  in the [Electrical Characteristics](#).

#### 8.3.4 $V_{CC}$ Isolation

The inputs and outputs for this device enter a high-impedance state when either supply is  $<100$  mV.

### 8.3.5 Over-Voltage Tolerant Inputs

Input signals to this device can be driven above the supply voltage so long as they remain below the maximum input voltage value specified in the [Recommended Operating Conditions](#).

### 8.3.6 Glitch-Free Power Supply Sequencing

Either supply rail may be powered on or off in any order without producing a glitch on the I/Os (that is, where the output erroneously transitions to VCC when it should be held low). Glitches of this nature can be misinterpreted by a peripheral as a valid data bit, which could trigger a false device reset of the peripheral, a false device configuration of the peripheral, or even a false data initialization by the peripheral. For more information regarding the power up glitch performance of the AXC family of level translators, see [Glitch Free Power Sequencing With AXC Level Translators](#).

### 8.3.7 Negative Clamping Diodes

The inputs and outputs to this device have negative clamping diodes as depicted in [图 8-1](#).

**CAUTION**

Voltages beyond the values specified in the [Absolute Maximum Ratings](#) table can cause damage to the device. The input negative-voltage and output voltage ratings may be exceeded if the input and output clamp-current ratings are observed.

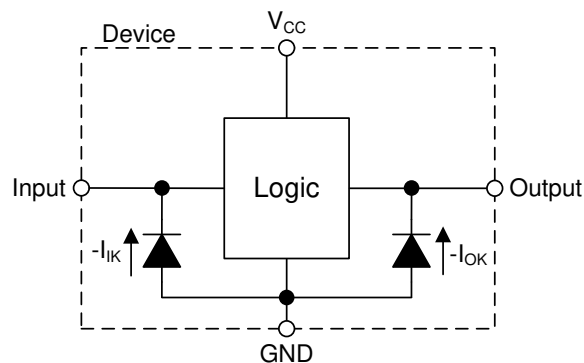

**图 8-1. Electrical Placement of Clamping Diodes for Each Input and Output**

### 8.3.8 Fully Configurable Dual-Rail Design

Both the  $V_{CCA}$  and  $V_{CCB}$  pins can be supplied at any voltage from 0.65 V to 3.6 V, making the device suitable for translating between any of the voltage nodes (0.7 V, 0.8 V, 0.9 V, 1.2 V, 1.8 V, 2.5 V, and 3.3 V).

### 8.3.9 Supports High-Speed Translation

The SN74AXC4T245-Q1 device can support high data-rate applications. The translated signal data rate can be up to 380 Mbps when the signal is translated from 1.8 V to 3.3 V.

### 8.3.10 Wettable Flanks

This device includes wettable flanks for at least one package. See the *Features* section on the front page of the data sheet for which packages include this feature.

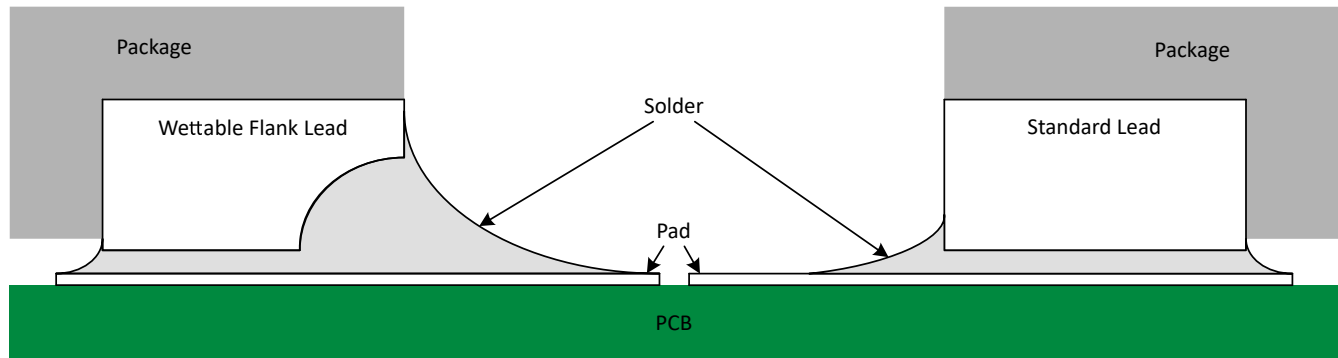

**图 8-2. Simplified Cutaway View of Wettable-Flank QFN Package and Standard QFN Package After Soldering**

Wettable flanks help improve side wetting after soldering which makes QFN packages easier to inspect with automatic optical inspection (AOI). A wettable flank can be dimpled or step-cut to provide additional surface area for solder adhesion which assists in reliably creating a side fillet as shown in 图 8-2. Please see the mechanical drawing for additional details.

### 8.4 Device Functional Modes

**表 8-1. Function Table (Each 2-Bit Section)**

CONTROL INPUTS <sup>(1) (2)</sup>		PORT STATUS		OPERATION
OE	DIR	A PORT	B PORT	
L	L	Output (Enabled)	Input (Hi-Z)	B data to A bus
L	H	Input (Hi-Z)	Output (Enabled)	A data to B bus
H	X	Input (Hi-Z)	Input (Hi-Z)	Isolation

(1) Input circuits of the data I/Os are always active.

(2) Pins configured as inputs should not be left floating.

## 9 Application and Implementation

### Note

以下应用部分中的信息不属于 TI 器件规格的范围，TI 不担保其准确性和完整性。TI 的客户应负责确定器件是否适用于其应用。客户应验证并测试其设计，以确保系统功能。

### 9.1 Application Information

The AEC-Q100 qualified SN74AXC4T245-Q1 device can be used in level-translation applications for interfacing devices or systems operating at different interface voltages with one another. The SN74AXC4T245-Q1 device is ideal for use in applications where a push-pull driver is connected to the data I/Os. The maximum data rate can be up to 380 Mbps when device translates a signal from 1.8 V to 3.3 V.

图 9-1 shows an example application where the SN74AXC4T245-Q1 device is used to translate a low voltage UART signal from an SoC to a higher voltage signal which properly drives the inputs of the Bluetooth® module, and vice versa.

### 9.2 Typical Application



图 9-1. UART Interface Application

#### 9.2.1 Design Requirements

For this design example, use the parameters listed in 表 9-1.

表 9-1. Design Parameters

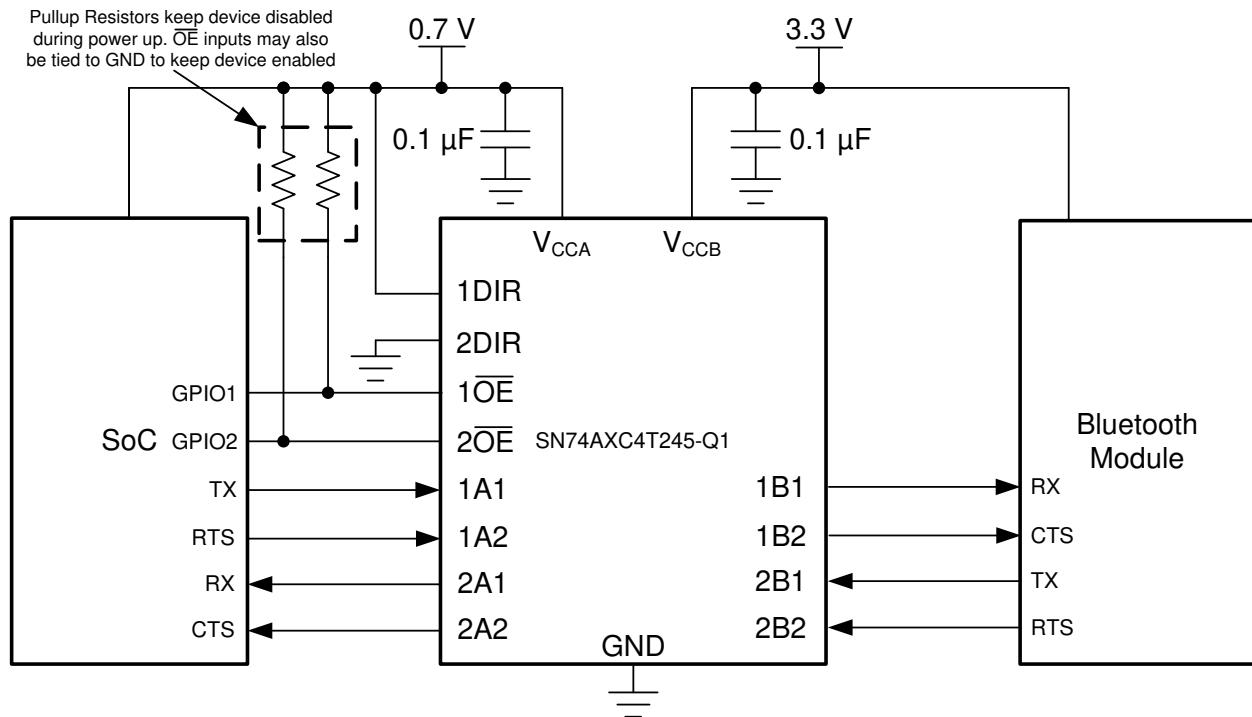
DESIGN PARAMETERS	EXAMPLE VALUES
Input voltage range	0.65 V to 3.6 V
Output voltage range	0.65 V to 3.6 V

### 9.2.2 Detailed Design Procedure

To begin the design process, determine the following:

- Input voltage range:
  - Use the supply voltage of the device that is driving the SN74AXC4T245-Q1 device to determine the input voltage range. For a valid logic-high, the value must exceed the high-level input voltage ( $V_{IH}$ ) of the input port. For a valid logic low the value must be less than the low-level input voltage ( $V_{IL}$ ) of the input port.
- Output voltage range:
  - Use the supply voltage of the device that the SN74AXC4T245-Q1 device is driving to determine the output voltage range.

### 9.2.3 Application Curve



图 9-2. Up Translation at 2.5 MHz (0.7 V to 3.3 V)

## 10 Power Supply Recommendations

Always apply a ground reference to the GND pins first. This device is designed for glitch free power sequencing without any supply sequencing requirements such as ramp order or ramp rate.

This device was designed with various power supply sequencing methods in mind to help prevent unintended triggering of downstream devices. For more information regarding the power up glitch performance of the AXC family of level translators, see [Glitch Free Power Sequencing With AXC Level Translators](#).

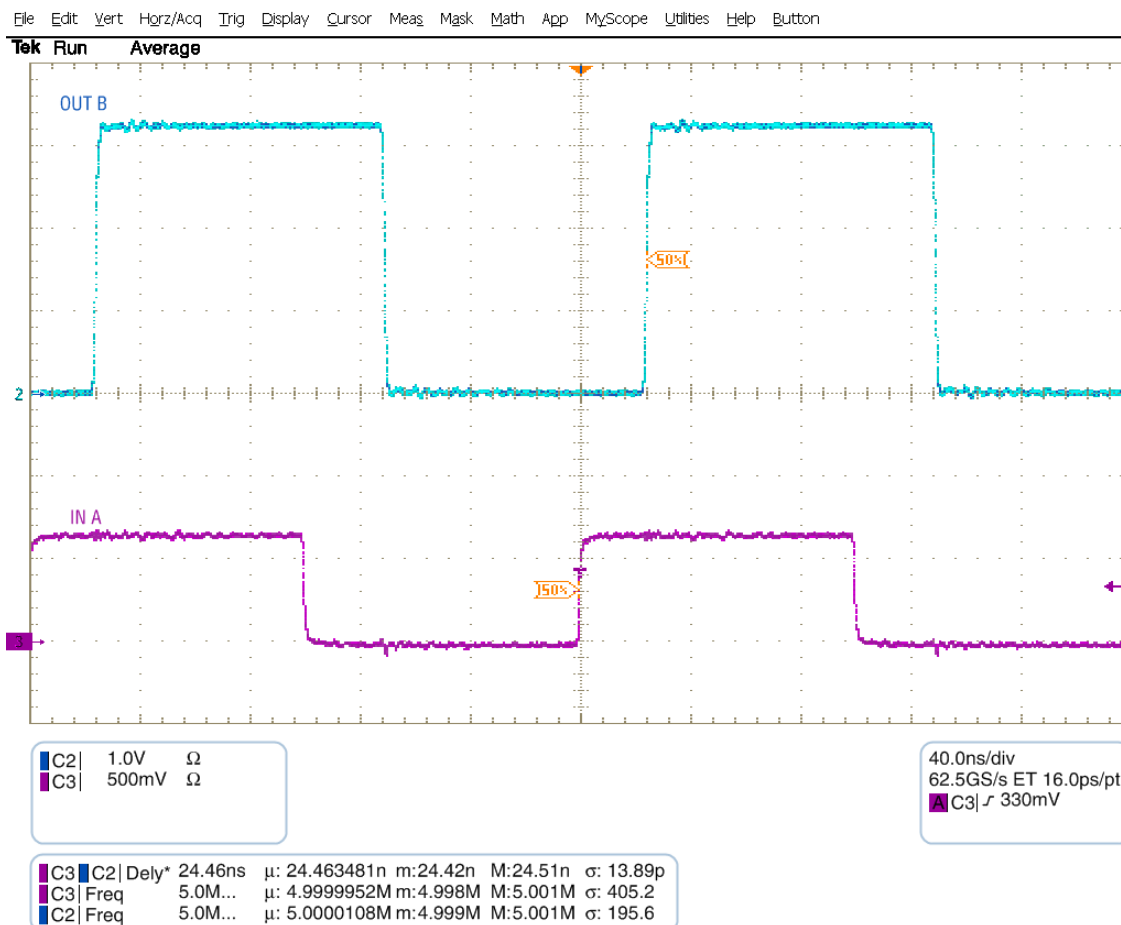
## 11 Layout

### 11.1 Layout Guidelines

To ensure reliability of the device, following common printed-circuit board layout guidelines are recommended:

- Use bypass capacitors on the power supply pins and place them as close to the device as possible.
- Use short trace lengths to avoid excessive loading.

### 11.2 Layout Example



图 11-1. Layout Example

## 12 Device and Documentation Support

### 12.1 Documentation Support

#### 12.1.1 Related Documentation

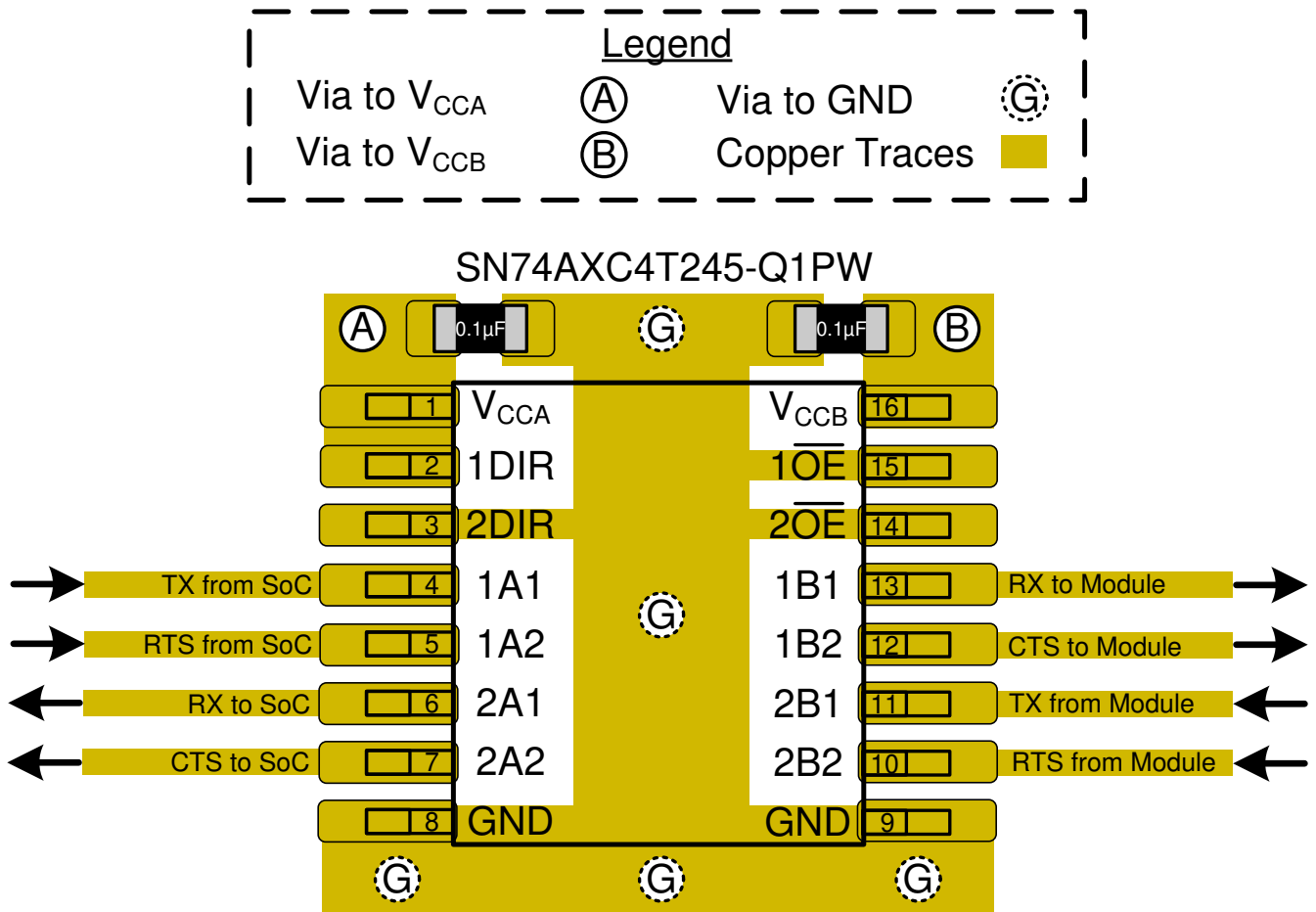
For related documentation see the following:

- Texas Instruments, [Glitch Free Power Sequencing With AXC Level Translators application report](#)
- Texas Instruments, [Implications of Slow or Floating CMOS Inputs application report](#)
- Texas Instruments, [Low Voltage Translation For Standard Interfaces application report](#)
- Texas Instruments, [Power Sequencing for AXC Family of Devices application report](#)
- Texas Instruments, [SN74AXC4T245RSV EVM evaluation module user's guide](#)
- Texas Instruments, [UART Interface Using SN74AXC4T245 video](#)

#### 12.2 接收文档更新通知

要接收文档更新通知，请导航至 [ti.com](http://ti.com) 上的器件产品文件夹。点击 [订阅更新](#) 进行注册，即可每周接收产品信息更改摘要。有关更改的详细信息，请查看任何已修订文档中包含的修订历史记录。

#### 12.3 支持资源

TI E2E™ [支持论坛](#) 是工程师的重要参考资料，可直接从专家获得快速、经过验证的解答和设计帮助。搜索现有解答或提出自己的问题可获得所需的快速设计帮助。

链接的内容由各个贡献者“按原样”提供。这些内容并不构成 TI 技术规范，并且不一定反映 TI 的观点；请参阅 TI 的 [《使用条款》](#)。

#### 12.4 Trademarks

TI E2E™ is a trademark of Texas Instruments.

Bluetooth® is a registered trademark of Bluetooth Special Interest Group (SIG).

所有商标均为其各自所有者的财产。

#### 12.5 Electrostatic Discharge Caution



This integrated circuit can be damaged by ESD. Texas Instruments recommends that all integrated circuits be handled with appropriate precautions. Failure to observe proper handling and installation procedures can cause damage.

ESD damage can range from subtle performance degradation to complete device failure. Precision integrated circuits may be more susceptible to damage because very small parametric changes could cause the device not to meet its published specifications.

#### 12.6 术语表

[TI 术语表](#) 本术语表列出并解释了术语、首字母缩略词和定义。

## 13 Mechanical, Packaging, and Orderable Information

The following pages include mechanical, packaging, and orderable information. This information is the most current data available for the designated devices. This data is subject to change without notice and revision of this document. For browser-based versions of this data sheet, refer to the left-hand navigation.

## PACKAGING INFORMATION

Orderable Device	Status (1)	Package Type	Package Drawing	Pins	Package Qty	Eco Plan (2)	Lead finish/ Ball material (6)	MSL Peak Temp (3)	Op Temp (°C)	Device Marking (4/5)	Samples
CAXC4T245QBQBRQ1	ACTIVE	WQFN	BQB	16	3000	RoHS & Green	NIPDAU	Level-1-260C-UNLIM	-40 to 125	4T245Q	<a href="#">Samples</a>
CAXC4T245QRSVRQ1	ACTIVE	UQFN	RSV	16	3000	RoHS & Green	NIPDAUAG	Level-1-260C-UNLIM	-40 to 125	1ZDR	<a href="#">Samples</a>
CAXC4T245QWBQBRQ1	ACTIVE	WQFN	BQB	16	3000	RoHS & Green	NIPDAU	Level-1-260C-UNLIM	-40 to 125	4T245Q	<a href="#">Samples</a>
SN74AXC4T245QPWRQ1	ACTIVE	TSSOP	PW	16	2000	RoHS & Green	NIPDAU	Level-1-260C-UNLIM	-40 to 125	4T245Q	<a href="#">Samples</a>

(1) The marketing status values are defined as follows:

**ACTIVE:** Product device recommended for new designs.

**LIFEBUY:** TI has announced that the device will be discontinued, and a lifetime-buy period is in effect.

**NRND:** Not recommended for new designs. Device is in production to support existing customers, but TI does not recommend using this part in a new design.

**PREVIEW:** Device has been announced but is not in production. Samples may or may not be available.

**OBSELETE:** TI has discontinued the production of the device.

(2) **RoHS:** TI defines "RoHS" to mean semiconductor products that are compliant with the current EU RoHS requirements for all 10 RoHS substances, including the requirement that RoHS substance do not exceed 0.1% by weight in homogeneous materials. Where designed to be soldered at high temperatures, "RoHS" products are suitable for use in specified lead-free processes. TI may reference these types of products as "Pb-Free".

**RoHS Exempt:** TI defines "RoHS Exempt" to mean products that contain lead but are compliant with EU RoHS pursuant to a specific EU RoHS exemption.

**Green:** TI defines "Green" to mean the content of Chlorine (Cl) and Bromine (Br) based flame retardants meet JS709B low halogen requirements of <=1000ppm threshold. Antimony trioxide based flame retardants must also meet the <=1000ppm threshold requirement.

(3) MSL, Peak Temp. - The Moisture Sensitivity Level rating according to the JEDEC industry standard classifications, and peak solder temperature.

(4) There may be additional marking, which relates to the logo, the lot trace code information, or the environmental category on the device.

(5) Multiple Device Markings will be inside parentheses. Only one Device Marking contained in parentheses and separated by a "-" will appear on a device. If a line is indented then it is a continuation of the previous line and the two combined represent the entire Device Marking for that device.

(6) Lead finish/Ball material - Orderable Devices may have multiple material finish options. Finish options are separated by a vertical ruled line. Lead finish/Ball material values may wrap to two lines if the finish value exceeds the maximum column width.

**Important Information and Disclaimer:**The information provided on this page represents TI's knowledge and belief as of the date that it is provided. TI bases its knowledge and belief on information provided by third parties, and makes no representation or warranty as to the accuracy of such information. Efforts are underway to better integrate information from third parties. TI has taken and

continues to take reasonable steps to provide representative and accurate information but may not have conducted destructive testing or chemical analysis on incoming materials and chemicals. TI and TI suppliers consider certain information to be proprietary, and thus CAS numbers and other limited information may not be available for release.

In no event shall TI's liability arising out of such information exceed the total purchase price of the TI part(s) at issue in this document sold by TI to Customer on an annual basis.

**OTHER QUALIFIED VERSIONS OF SN74AXC4T245-Q1 :**

- Catalog : [SN74AXC4T245](#)

NOTE: Qualified Version Definitions:

- Catalog - TI's standard catalog product

**TAPE AND REEL INFORMATION**

**QUADRANT ASSIGNMENTS FOR PIN 1 ORIENTATION IN TAPE**

\*All dimensions are nominal

Device	Package Type	Package Drawing	Pins	SPQ	Reel Diameter (mm)	Reel Width W1 (mm)	A0 (mm)	B0 (mm)	K0 (mm)	P1 (mm)	W (mm)	Pin1 Quadrant
CAXC4T245QBQBRQ1	WQFN	BQB	16	3000	180.0	12.4	2.8	3.8	1.2	4.0	12.0	Q1
CAXC4T245QRSVRQ1	UQFN	RSV	16	3000	178.0	13.5	2.1	2.9	0.75	4.0	12.0	Q1
CAXC4T245QWBQBRQ1	WQFN	BQB	16	3000	180.0	12.4	2.8	3.8	1.2	4.0	12.0	Q1
SN74AXC4T245QPWRQ1	TSSOP	PW	16	2000	330.0	12.4	6.9	5.6	1.6	8.0	12.0	Q1

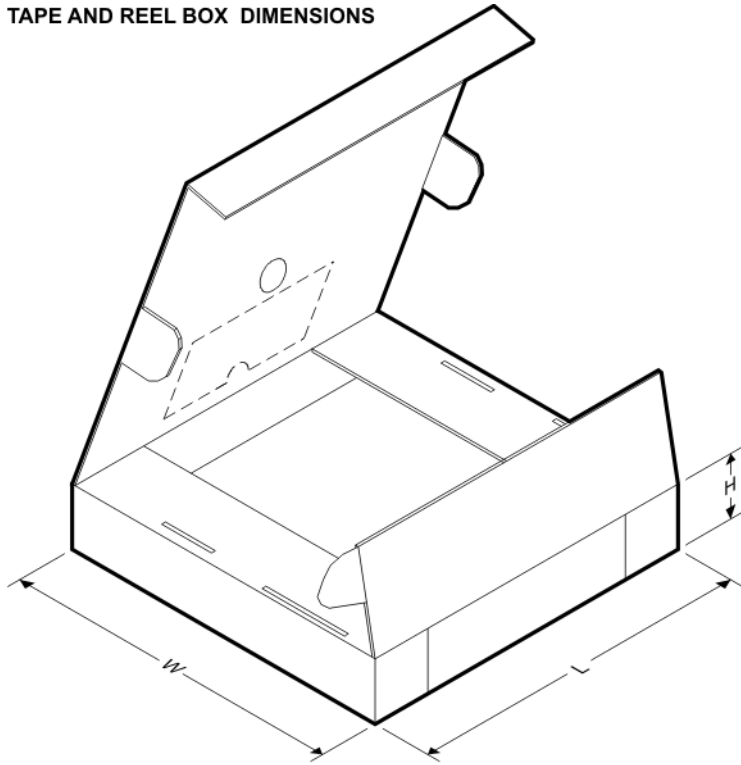
**TAPE AND REEL BOX DIMENSIONS**

\*All dimensions are nominal

Device	Package Type	Package Drawing	Pins	SPQ	Length (mm)	Width (mm)	Height (mm)
CAXC4T245QBQBRQ1	WQFN	BQB	16	3000	210.0	185.0	35.0
CAXC4T245QRSVRQ1	UQFN	RSV	16	3000	189.0	185.0	36.0
CAXC4T245QWBQBRQ1	WQFN	BQB	16	3000	210.0	185.0	35.0
SN74AXC4T245QPWRQ1	TSSOP	PW	16	2000	853.0	449.0	35.0



# EXAMPLE BOARD LAYOUT

RSV0016A

UQFN - 0.55 mm max height

ULTRA THIN QUAD FLATPACK - NO LEAD

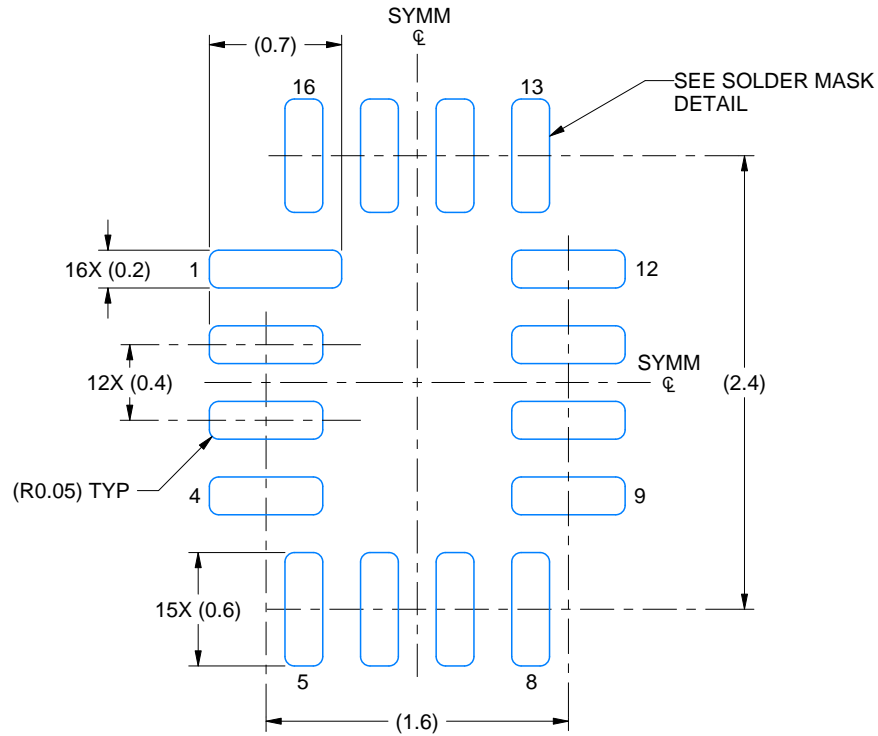

LAND PATTERN EXAMPLE  
EXPOSED METAL SHOWN  
SCALE: 25X

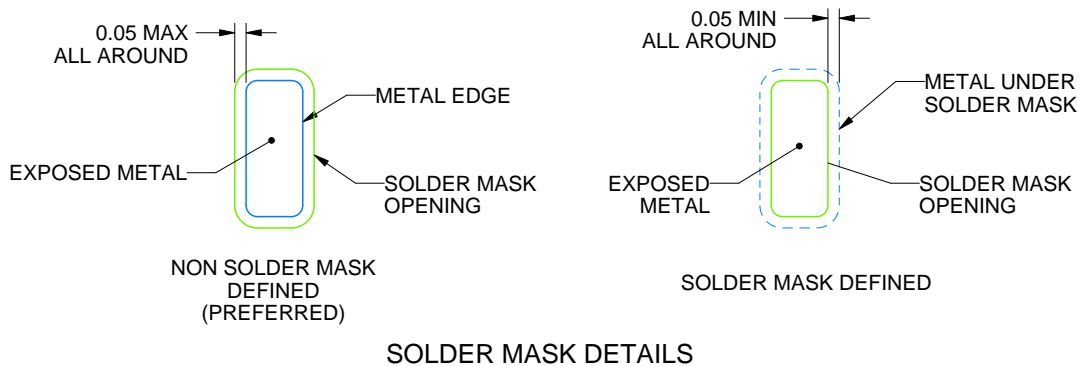

4220314/C 02/2020

NOTES: (continued)

3. For more information, see Texas Instruments literature number SLUA271 ([www.ti.com/lit/slua271](http://www.ti.com/lit/slua271)).

# EXAMPLE STENCIL DESIGN

RSV0016A

UQFN - 0.55 mm max height

ULTRA THIN QUAD FLATPACK - NO LEAD

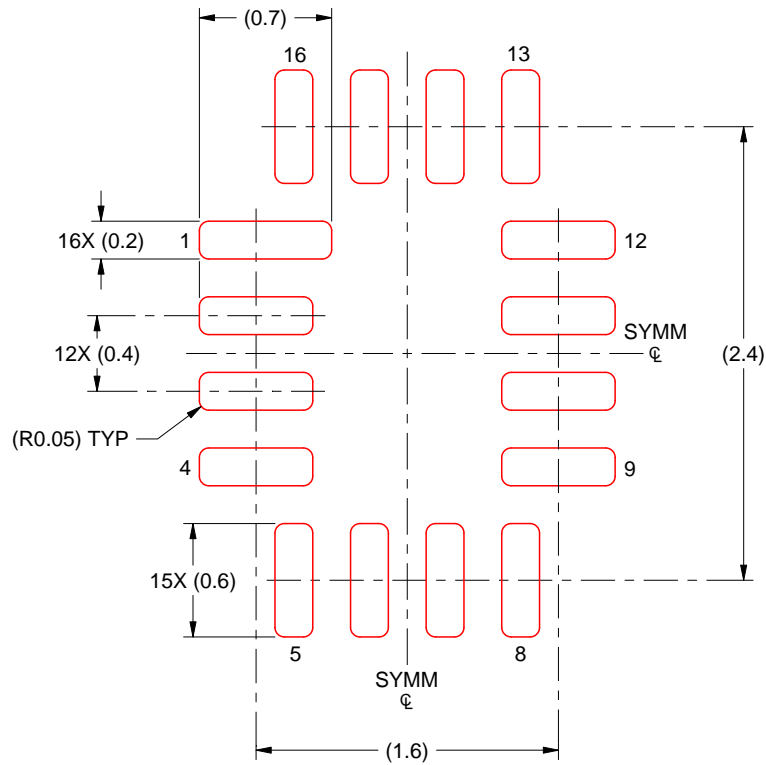

SOLDER PASTE EXAMPLE  
BASED ON 0.125 MM THICK STENCIL  
SCALE: 25X

4220314/C 02/2020

NOTES: (continued)

4. Laser cutting apertures with trapezoidal walls and rounded corners may offer better paste release. IPC-7525 may have alternate design recommendations.



4220204/A 02/2017

NOTES:

1. All linear dimensions are in millimeters. Any dimensions in parenthesis are for reference only. Dimensioning and tolerancing per ASME Y14.5M.
2. This drawing is subject to change without notice.
3. This dimension does not include mold flash, protrusions, or gate burrs. Mold flash, protrusions, or gate burrs shall not exceed 0.15 mm per side.
4. This dimension does not include interlead flash. Interlead flash shall not exceed 0.25 mm per side.
5. Reference JEDEC registration MO-153.

# EXAMPLE BOARD LAYOUT

PW0016A

TSSOP - 1.2 mm max height

SMALL OUTLINE PACKAGE



LAND PATTERN EXAMPLE  
EXPOSED METAL SHOWN  
SCALE: 10X

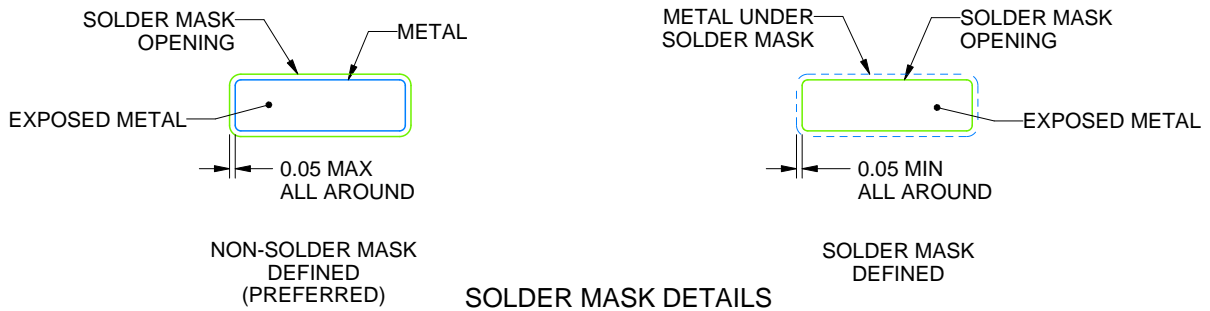

4220204/A 02/2017

NOTES: (continued)

- 6. Publication IPC-7351 may have alternate designs.
- 7. Solder mask tolerances between and around signal pads can vary based on board fabrication site.

# EXAMPLE STENCIL DESIGN

PW0016A

TSSOP - 1.2 mm max height

SMALL OUTLINE PACKAGE



SOLDER PASTE EXAMPLE  
BASED ON 0.125 mm THICK STENCIL  
SCALE: 10X

4220204/A 02/2017

NOTES: (continued)

8. Laser cutting apertures with trapezoidal walls and rounded corners may offer better paste release. IPC-7525 may have alternate design recommendations.
9. Board assembly site may have different recommendations for stencil design.

## GENERIC PACKAGE VIEW

**BQB 16**

**WQFN - 0.8 mm max height**

2.5 x 3.5, 0.5 mm pitch

PLASTIC QUAD FLATPACK - NO LEAD

This image is a representation of the package family, actual package may vary.  
Refer to the product data sheet for package details.

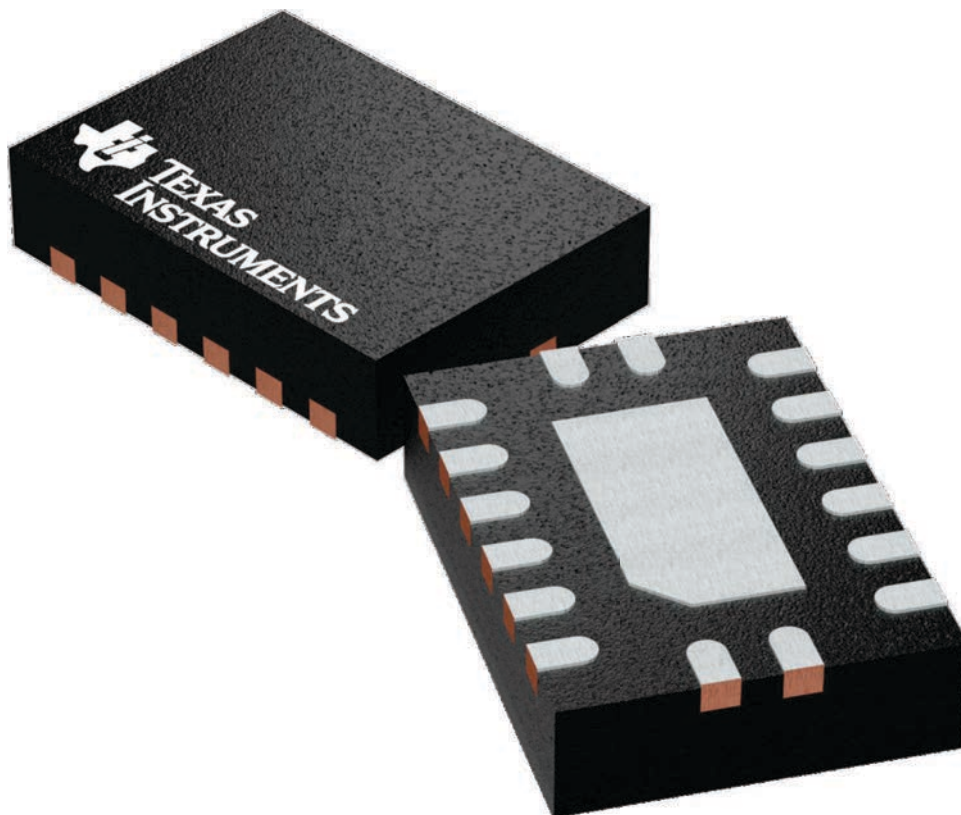

4226161/A

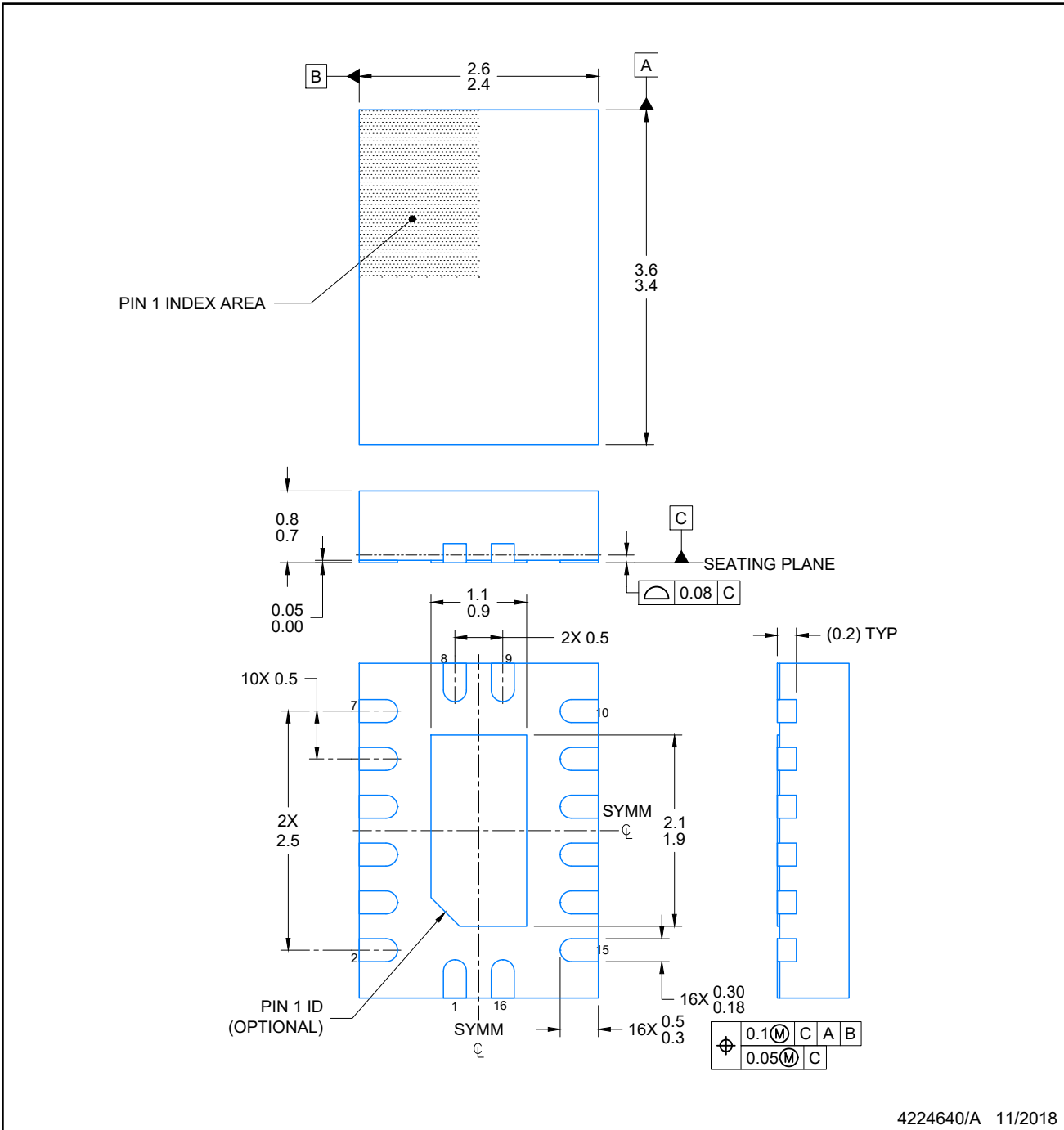

4224640/A 11/2018

**NOTES:**

1. All linear dimensions are in millimeters. Any dimensions in parenthesis are for reference only. Dimensioning and tolerancing per ASME Y14.5M.
2. This drawing is subject to change without notice.
3. The package thermal pad must be soldered to the printed circuit board for optimal thermal and mechanical performance.



# EXAMPLE STENCIL DESIGN

BQB0016A

WQFN - 0.8 mm max height

PLASTIC QUAD FLAT PACK-NO LEAD

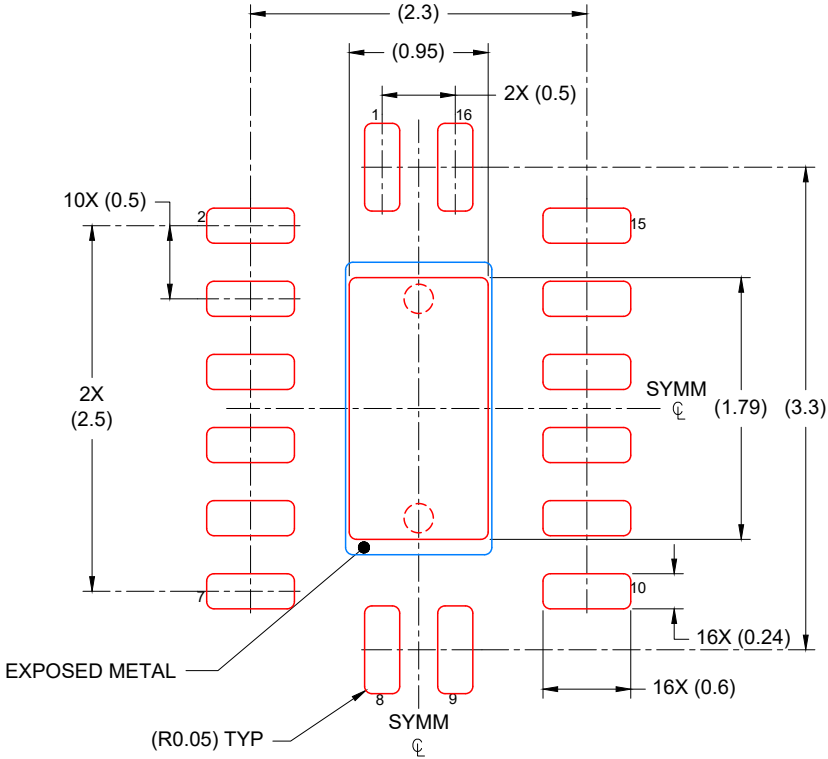

SOLDER PASTE EXAMPLE  
 BASED ON 0.125 mm THICK STENCIL

EXPOSED PAD  
 85% PRINTED COVERAGE BY AREA  
 SCALE: 20X

4224640/A 11/2018

NOTES: (continued)

- 6. Laser cutting apertures with trapezoidal walls and rounded corners may offer better paste release. IPC-7525 may have alternate design recommendations.

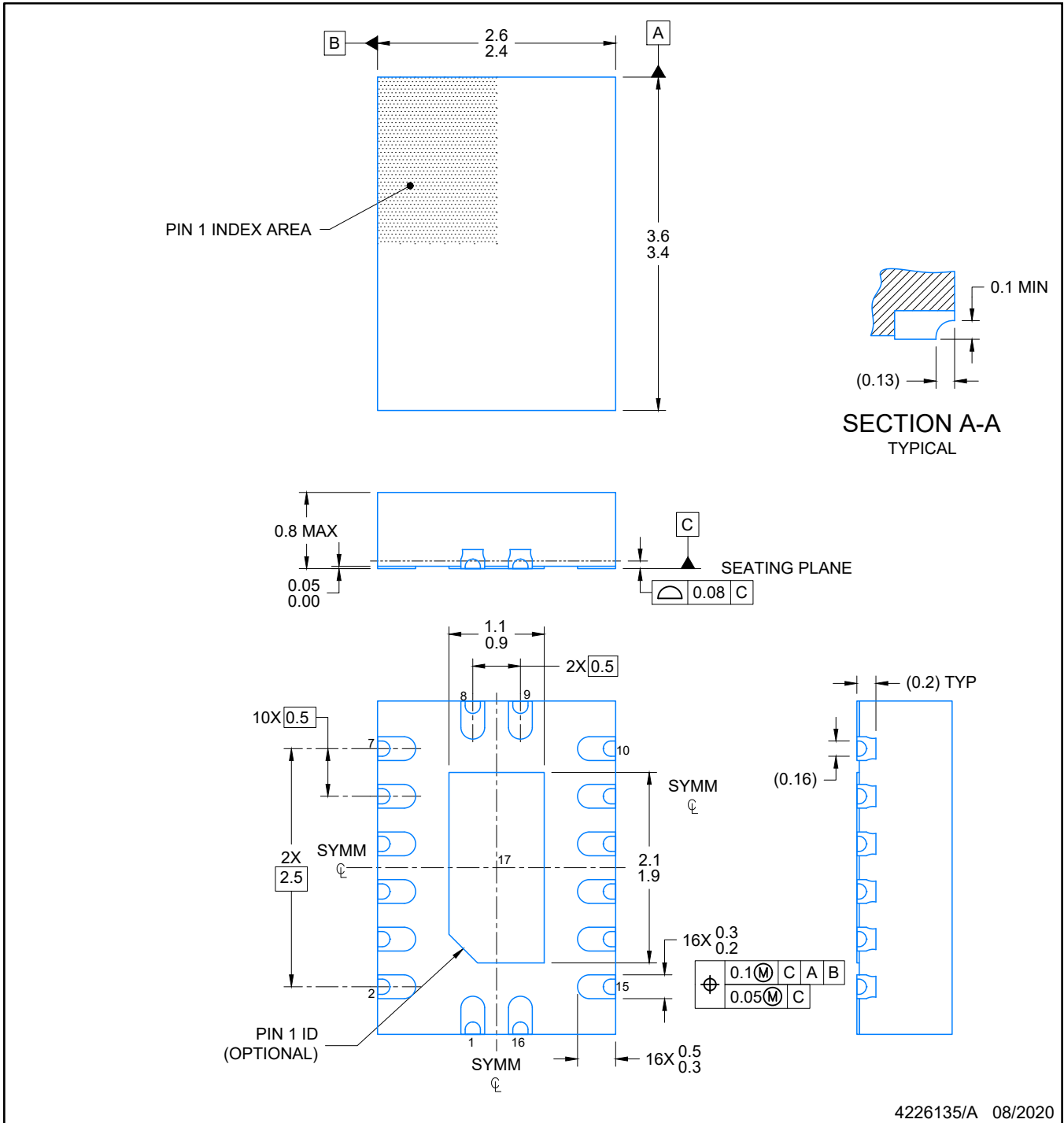

**NOTES:**

1. All linear dimensions are in millimeters. Any dimensions in parenthesis are for reference only. Dimensioning and tolerancing per ASME Y14.5M.
2. This drawing is subject to change without notice.
3. The package thermal pad must be soldered to the printed circuit board for optimal thermal and mechanical performance.



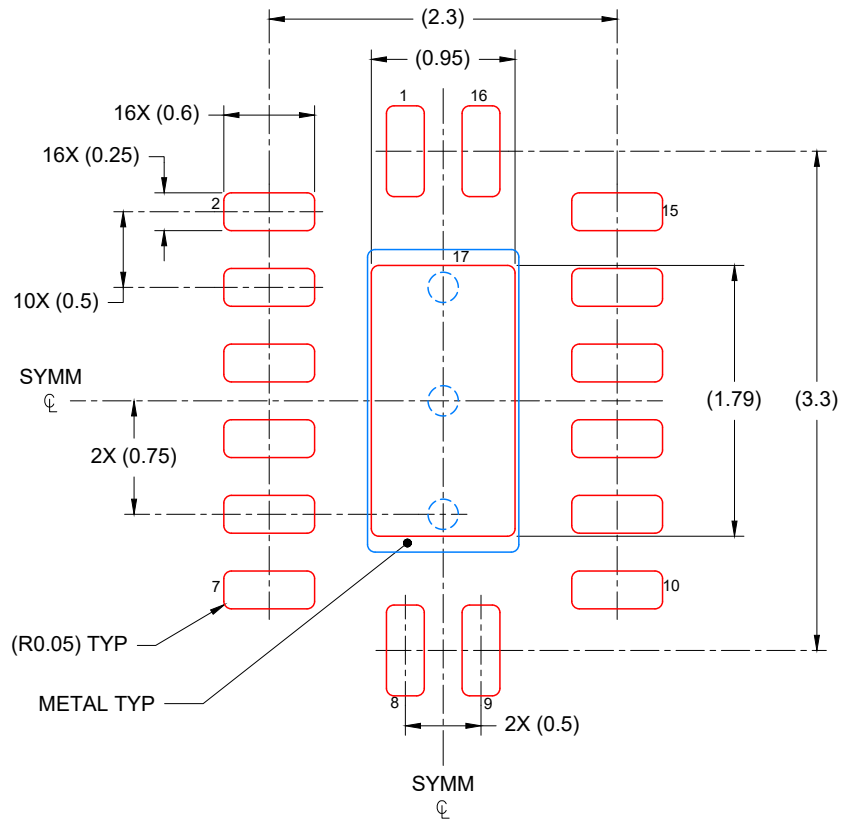

SOLDER PASTE EXAMPLE  
 BASED ON 0.125 mm THICK STENCIL

EXPOSED PAD  
 85% PRINTED COVERAGE BY AREA  
 SCALE: 20X

4226135/A 08/2020

NOTES: (continued)

- 6. Laser cutting apertures with trapezoidal walls and rounded corners may offer better paste release. IPC-7525 may have alternate design recommendations.

## 重要声明和免责声明

TI“按原样”提供技术和可靠性数据（包括数据表）、设计资源（包括参考设计）、应用或其他设计建议、网络工具、安全信息和其他资源，不保证没有瑕疵且不做任何明示或暗示的担保，包括但不限于对适销性、某特定用途方面的适用性或不侵犯任何第三方知识产权的暗示担保。

这些资源可供使用 TI 产品进行设计的熟练开发人员使用。您将自行承担以下全部责任：(1) 针对您的应用选择合适的 TI 产品，(2) 设计、验证并测试您的应用，(3) 确保您的应用满足相应标准以及任何其他功能安全、信息安全、监管或其他要求。

这些资源如有变更，恕不另行通知。TI 授权您仅可将这些资源用于研发本资源所述的 TI 产品的应用。严禁对这些资源进行其他复制或展示。您无权使用任何其他 TI 知识产权或任何第三方知识产权。您应全额赔偿因在这些资源的使用中对 TI 及其代表造成的任何索赔、损害、成本、损失和债务，TI 对此概不负责。

TI 提供的产品受 [TI 的销售条款](#) 或 [ti.com](#) 上其他适用条款/TI 产品随附的其他适用条款的约束。TI 提供这些资源并不会扩展或以其他方式更改 TI 针对 TI 产品发布的适用的担保或担保免责声明。

TI 反对并拒绝您可能提出的任何其他或不同的条款。

邮寄地址：Texas Instruments, Post Office Box 655303, Dallas, Texas 75265

Copyright © 2022，德州仪器 (TI) 公司