

## TPS92310 Off-Line Primary Side Sensing Controller With PFC

Check for Samples: [TPS92310](#)

### FEATURES

- Regulates LED Current Without Secondary Side Sensing
- Adaptive ON-Time Control With Inherent PFC
- Critical-Conduction-Mode (CRM) With Zero-Current Detection (ZCD) for Valley Switching
- Programmable Switch Turn ON Delay
- Programmable Constant ON-Time (COT) and Peak Current Control
- Over-Temperature Protection

### APPLICATIONS

- LED Lamps: A19 (E26/27, E14), PAR30/38, GU10
- Solid State Lighting

### DESCRIPTION

The TPS92310 is an off-line controller specifically designed to drive high power LEDs for lighting applications. With the primary side sensing, constant on-time and quasi-resonant switching techniques, the TPS92310 application circuit gives high Power Factor, good EMI performance and high system efficiency. Also, using this device, low external component count application solutions can be designed easily. Power Factor Correction is inherent if the TPS92310 is operated in the constant on-time mode with an adaptive algorithm. The control algorithm of TPS92310 adjusts the on-time with reference to the primary side inductor peak current and secondary side inductor discharge time dynamically, the response time of which is set by an external capacitor. Also, minimized EMI and switching loss is achieved with quasi-resonant switching. Other supervisory features of the TPS92310 include cycle-by-cycle primary side inductor current limit, VCC under-voltage lockout, output over-voltage protection and thermal shutdown. The TPS92310 is available in the VSSOP-10 package.

### Typical Application

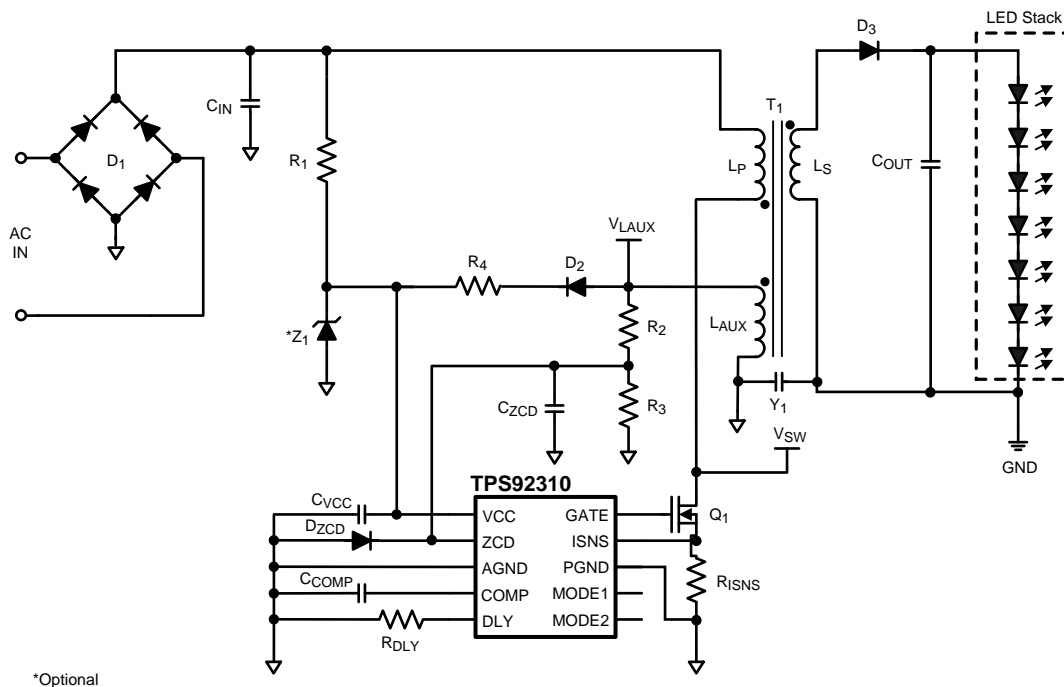
**Figure 1.**

Please be aware that an important notice concerning availability, standard warranty, and use in critical applications of Texas Instruments semiconductor products and disclaimers thereto appears at the end of this data sheet.

All trademarks are the property of their respective owners.

## Connection Diagram

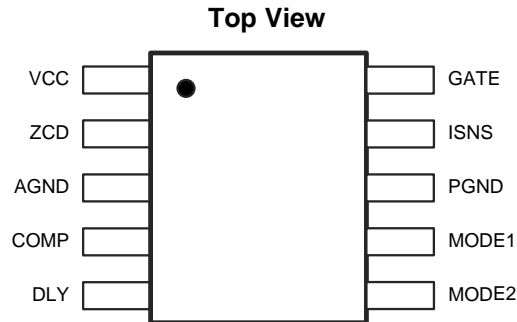

**Figure 2. 10-Pin VSSOP**

### Pin Descriptions

Pin	Name	Description	Application Information
1	VCC	Power supply input	This pin provides power to the internal control circuitry and gate driver. Connect a 10 $\mu$ F capacitor from this pin to ground.
2	ZCD	Zero crossing detection input	The pin senses the voltage of the auxiliary winding for zero current detection.
3	AGND	Small signal ground	Signal ground.
4	COMP	Compensation network	Output of the error amplifier. Connect a capacitor from this pin to ground to set the frequency response of the LED current regulation loop.
5	DLY	Delay control input	Connect a resistor from this pin to ground to set the delay between switching ON and OFF periods.
6	MODE2	Mode selection input 2	Select operating mode for isolated or non-isolated mode.
7	MODE1	Mode selection input 1	Select operating mode for peak current mode or constant ON time.
8	PGND	Power ground	Power ground. This pin must be connected to the AGND pin externally for normal operation. This pin has no internal connection to PGND.
9	ISNS	Current sense voltage feedback	Switch current sensing input.
10	GATE	Gate driver output	Gate driving signal to the external switching MOSFET.



These devices have limited built-in ESD protection. The leads should be shorted together or the device placed in conductive foam during storage or handling to prevent electrostatic damage to the MOS gates.

### Absolute Maximum Ratings<sup>(1)(2)</sup>

VCC to GND	-0.3V to 40V
DLY, COMP, ZCD to GND	-0.3V to 7V
ISNS to GND	-0.3V to 7V
GATE to GND	-0.3V to 12V (5ns, -5V)
MODE1 to GND	-0.3V to 7V
MODE2 to GND	-0.3V to 7V
ESD Rating, HBM <sup>(3)</sup>	±2 kV
Machine Model	200V
Storage Temperature Range	-65°C to +125°C
Junction Temperature	+150°C

- (1) Absolute maximum ratings are limits beyond which damage to the device may occur. Operating Ratings are conditions for which the device is intended to be functional, but device parameter specifications may not be ensured. For ensured specifications and test conditions, see the Electrical Characteristics. All voltages are with respect to the potential at the GND pin, unless otherwise specified.
- (2) If Military/Aerospace specified devices are required, please contact the Texas Instruments Sales Office/Distributors for availability and specifications.
- (3) Human Body Model, applicable std. JESD22-A114-C.

### Operating Conditions

Supply Voltage range VCC	13V to 36V
Junction Temperature (T <sub>J</sub> )	-40°C to +125°C
Thermal Resistance (θ <sub>JA</sub> ) <sup>(1)</sup>	120°C/W

- (1) Junction-to-ambient thermal resistance is highly application and board-layout dependent. In applications where high maximum power dissipation exists, special care must be paid to thermal dissipation issues in board design. In applications where high power dissipation and/or poor package thermal resistance is present, the maximum ambient temperature may have to be derated. Maximum ambient temperature (T<sub>A-MAX</sub>) is dependent on the maximum operating junction temperature (T<sub>J-MAX-OP</sub> = 125°C), the maximum power dissipation of the device in the application (P<sub>D-MAX</sub>), and the junction-to ambient thermal resistance of the part/package in the application (R<sub>θJA</sub>), as given by the following equation: T<sub>A-MAX</sub> = T<sub>J-MAX-OP</sub> – (R<sub>θJA</sub> × P<sub>D-MAX</sub>).

### Electrical Characteristics

V<sub>CC</sub> = 18V unless otherwise indicated. Typical and limits appearing in plain type apply for T<sub>A</sub> = T<sub>J</sub> = +25°C. Limits appearing in **boldface** type apply over the full Operating Temperature Range. Data sheet minimum and maximum specification limits are specified by design, test or statistical analysis.

Symbol	Parameter	Conditions	Min	Typ	Max	Units
<b>SUPPLY VOLTAGE INPUT (VCC)</b>						
V <sub>CC-UVLO</sub>	VCC Turn on threshold		23.4 / <b>23</b>	25.6	27.8 / <b>29</b>	V
	VCC Turn off threshold		11.1 / <b>10.4</b>	13	14.7 / <b>15.7</b>	V
	Hysteresis			12.6		
I <sub>STARTUP</sub>	Startup Current	V <sub>CC</sub> = V <sub>CC-UVLO</sub> – 3.0V	<b>10</b>	12.5	<b>14.75</b>	μA
I <sub>VCC</sub>	Operating supply current	Not switching	<b>0.9</b>	1.2	<b>1.5</b>	mA
		65kHz switching, C <sub>LOAD</sub> = 1nF		2		mA
<b>ZERO CROSS DETECT (ZCD)</b>						
I <sub>ZCD</sub>	ZCD bias current	V <sub>ZCD</sub> = 5V		0.1	1	μA
V <sub>ZCD-OVP</sub>	ZCD over-voltage threshold		<b>4.1</b>	4.3	<b>4.5</b>	V
T <sub>OVP</sub>	Over voltage de-bounce time			3		cycle
V <sub>ZCD-ARM</sub>	ZCD Arming threshold	V <sub>ZCD</sub> = Increasing	<b>1.16</b>	1.24	<b>1.3</b>	V
V <sub>ZCD-TRIG</sub>	ZCD Trigger threshold	V <sub>ZCD</sub> = Decreasing	<b>0.48</b>	0.6	<b>0.77</b>	V
V <sub>ZCD-HYS</sub>	ZCD Hysteresis	V <sub>ZCD-ARM</sub> – V <sub>ZCD-TRIG</sub>		0.64		V

## Electrical Characteristics (continued)

$V_{CC} = 18V$  unless otherwise indicated. Typical and limits appearing in plain type apply for  $T_A = T_J = +25^\circ C$ . Limits appearing in **boldface** type apply over the full Operating Temperature Range. Data sheet minimum and maximum specification limits are specified by design, test or statistical analysis.

Symbol	Parameter	Conditions	Min	Typ	Max	Units
<b>COMPENSATION (COMP)</b>						
$I_{COMP-SOURCE}$	Internal reference current for primary side current regulation	$V_{COMP} = 2.0V$ , $V_{ISNS} = 0V$ , Measure at COMP pin		27		$\mu A$
$g_{mISNS}$	ISNS error amp transconductance	$\Delta V_{ISNS}$ to $\Delta I_{COMP}$ @ $V_{COMP} = 2.5V$		100		$\mu mho$
$V_{COMP}$	COMP operating range		2.0		3.5	V
<b>DELAY CONTROL (DLY)</b>						
$V_{DLY}$	DLY pin internal reference voltage		<b>1.21</b>	1.23	<b>1.26</b>	V
$I_{DLY-MAX}$	DLY source current	$V_{DLY} = 0V$	<b>250</b>			$\mu A$
<b>CURRENT SENSE (ISNS)</b>						
$V_{ISNS-OC}$	Over Current Detection Threshold	Non isolation mode	0.59	0.64	0.68	V
$V_{ISNS-OC}$	Over Current Detection Threshold	Isolation mode	3.2	3.4	3.6	V
$I_{ISNS}$	Current Sense Bias Current	$V_{ISNS} = 5V$	-1		1	$\mu A$
$T_{OCP}$	Over current Detection Propagation Delay	Measure GATE pulse width at $V_{ISNS} = 5V$		210		ns
<b>GATE DRIVER (GATE)</b>						
$V_{GATE-H}$	GATE high drive voltage	$I_{GATE} = 50mA$ source	<b>8</b>	9.4	<b>11.86</b>	V
$V_{GATE-L}$	GATE low drive voltage	$I_{GATE} = 50mA$ sink	<b>28</b>	80	<b>167</b>	mV
$T_{ON-MIN}$	Minimum ON time		<b>360</b>	540	<b>720</b>	ns
$T_{OFF-MAX}$	Maximum OFF time	ZCD = GND	<b>50</b>	72	<b>94</b>	$\mu s$
$t_{GATE-RISE}$	Rise time	$C_{LOAD} = 1nF$		110		ns
$t_{GATE-FALL}$	Fall time	$C_{LOAD} = 1nF$		20		ns
<b>THERMAL SHUTDOWN</b>						
TSD	Thermal shutdown temperature <sup>(1)</sup>			165		$^\circ C$
	Thermal Shutdown hysteresis			20		$^\circ C$

(1) Internal thermal shutdown circuitry protects the device from permanent damage. Thermal shutdown engages at  $T_J = 165^\circ C$  (typ.) and disengages at  $T_J = 145^\circ C$  (typ).

### Typical Performance Characteristics

All curves taken at  $V_{CC}=18V$  with configuration in typical application for driving seven power LEDs with  $I_{LED}=350mA$  shown in this datasheet.  $T_A=25^\circ C$ , unless otherwise specified.

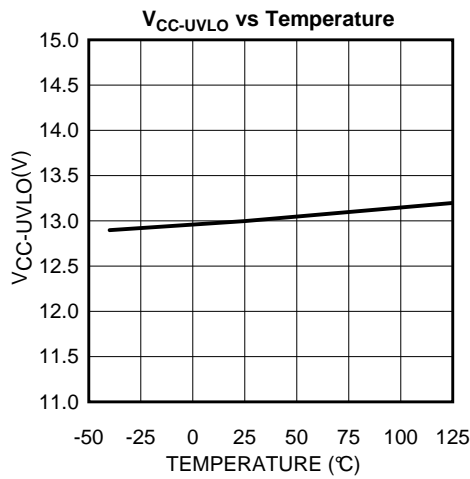

Figure 3.

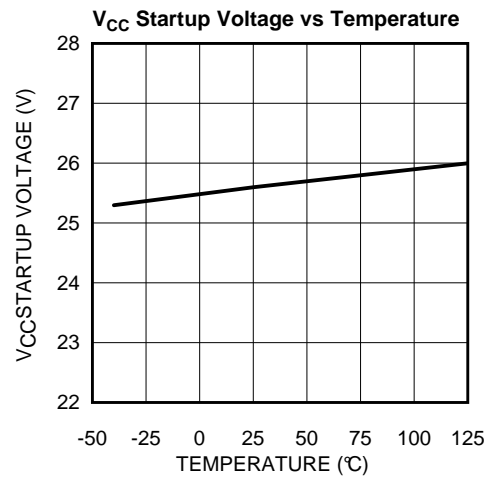

Figure 4.

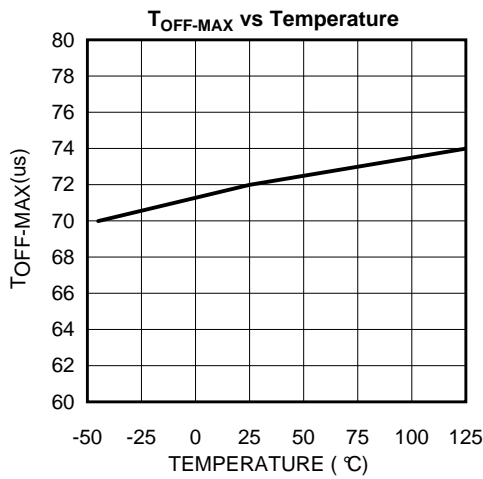

Figure 5.

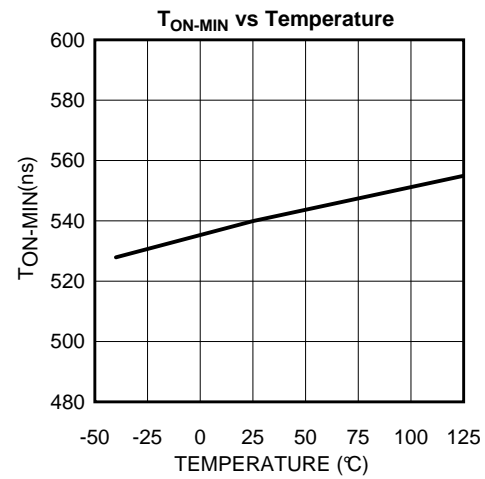

Figure 6.

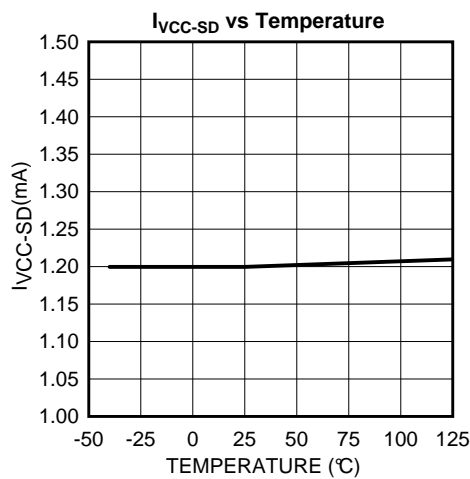

Figure 7.

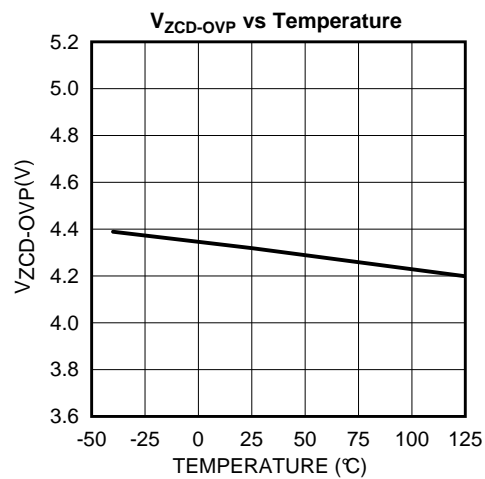

Figure 8.

**Typical Performance Characteristics (continued)**

All curves taken at  $V_{CC}=18V$  with configuration in typical application for driving seven power LEDs with  $I_{LED}=350mA$  shown in this datasheet.  $T_A=25^{\circ}C$ , unless otherwise specified.

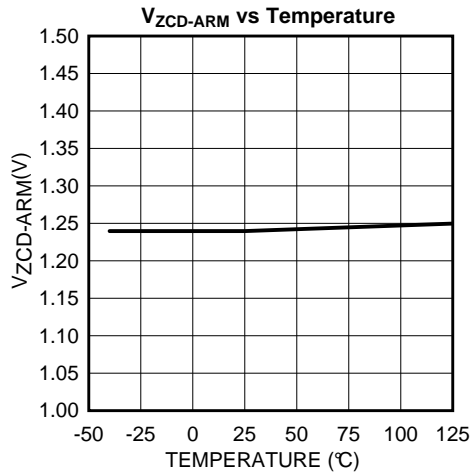

Figure 9.

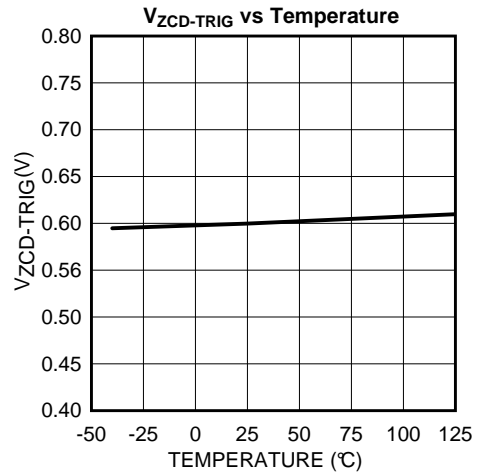

Figure 10.

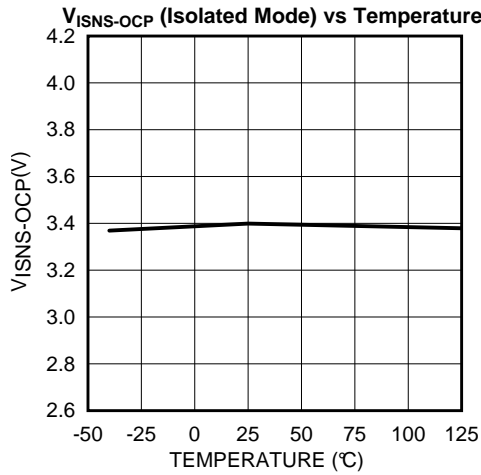

Figure 11.

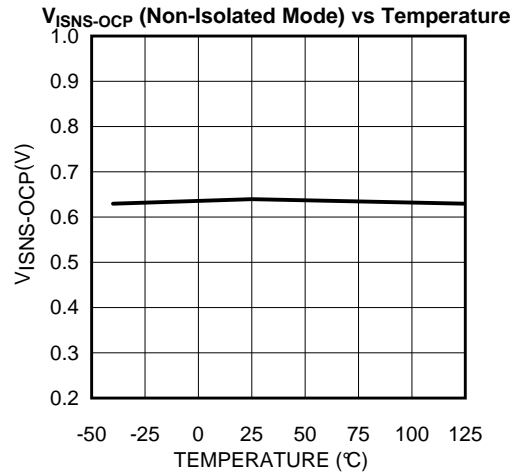

Figure 12.

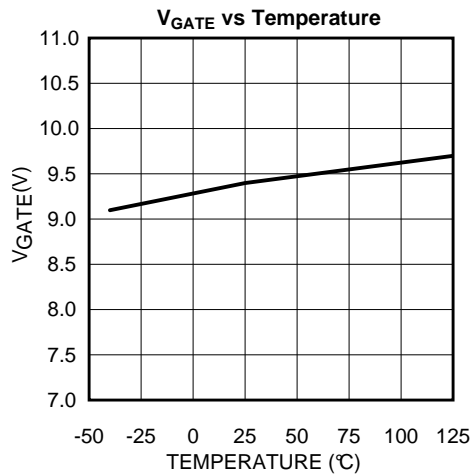

Figure 13.

SIMPLIFIED INTERNAL BLOCK DIAGRAM

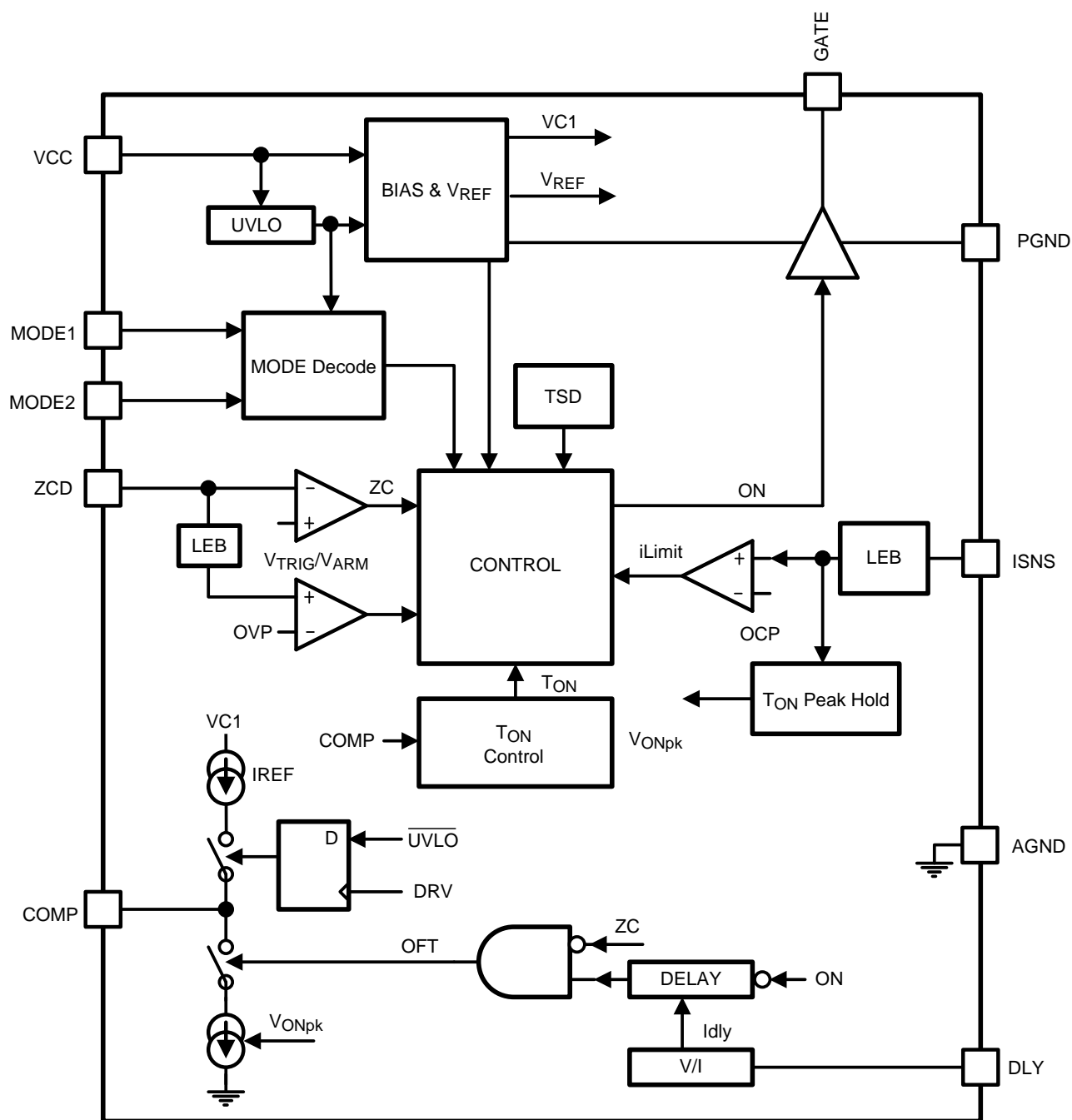
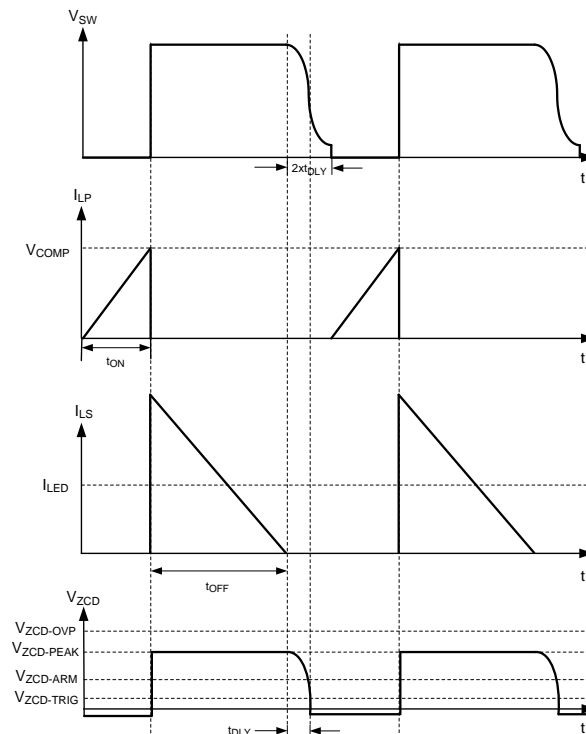

Figure 14. Simplified Block Diagram

## Application Information

The TPS92310 is an off-line controller specifically designed to drive LEDs with inherent Power Factor Correction (PFC). This device operates in Critical Conduction Mode (CRM) with adaptive Constant ON-Time control, so that high power factor can be achieved naturally. The TPS92310 can be used in isolated and non-isolated off-line applications that cover most requirements for LED lighting applications. A typical application schematic is shown in Figure 1. On the primary side, the off-line flyback converter consists of a transformer which includes three windings  $L_P$ ,  $L_S$  and  $L_{AUX}$ , an external MOSFET  $Q_1$  and inductor current sensing resistor  $R_{ISNS}$ . On the output side, the  $L_S$  winding, the output diode  $D_3$ , the output capacitor  $C_{OUT}$  and a LED string connected as the load. Additionally, an auxiliary supply circuit to power the TPS92310 after start-up with  $L_{AUX}$  output is implemented. The  $L_{AUX}$  output voltage,  $V_{LAUX}$  is also used to detect the zero crossing point due to the end of a complete switching cycle. During the on-period,  $Q_1$  is turned on, the AC line input is rectified by the input bridge rectifier  $D_1$  and input capacitor  $C_{IN}$  and current flows through  $L_P$ ,  $Q_1$  and  $R_{ISNS}$  to ground, input energy is stored in the primary inductor  $L_P$ . Simultaneously, the ISNS pin of the device monitors the voltage of the current sensing resistor  $R_{ISNS}$  to perform the cycle-by-cycle inductor current limit function. While the MOSFET  $Q_1$  turned off, current flow in  $L_P$  ceased and the energy stored during the on cycle is released to output and auxiliary circuits. The current in the secondary winding  $L_S$  charges the output capacitor  $C_{OUT}$  through  $D_3$  and supplies the LED load, the  $C_{OUT}$  also responsible to supply current to LED load during subsequent on-period. The current flows through  $L_{AUX}$  powers the TPS92310 through  $D_2$  and  $C_{VCC}$  in steady state operation. The voltage across  $L_{AUX}$ ,  $V_{LAUX}$  is fed back to the ZCD pin through a resistor divider network formed by  $R_2$  and  $R_3$  to perform zero crossing detection of  $V_{LAUX}$ , which determines the end of the off-period of a switching cycle. The next on-period of a new cycle will be initiated after an inserted delay of  $2 \times t_{DLY}$ , the  $t_{DLY}$  is programmable by a single resistor connecting the DLY pin and ground. The setting of the delay time,  $t_{DLY}$  will be described in separate paragraph.

During steady state operation, the duration of the on-period  $t_{ON}$  can be determined with two different modes: the Constant On-Time (COT) mode and the Peak Current Mode (PCM), which are configured by setting the MODE1 and MODE2 pins. For the COT mode,  $t_{ON}$  is generated by comparing an internal fixed saw-tooth wave with the voltage on the COMP pin,  $V_{COMP}$ . Since  $V_{COMP}$  is slow varying,  $t_{ON}$  is nearly constant within an AC line cycle. For the PCM, the on-period is terminated when the voltage of the ISNS pin,  $V_{ISNS}$  reaches a threshold determined by  $V_{COMP}$ . Since the instantaneous input voltage (AC voltage) varies,  $t_{ON}$  varies accordingly within an AC line cycle. The duration of the off-period  $t_{OFF}$  is determined by the rate of discharging of  $L_S$ , which is governed by  $I_{LS-PEAK}$  and  $V_{LED}$ . Also,  $I_{LS-PEAK}$  equals to  $n \times I_{LP-PEAK}$  where  $n$  is the turn ratio of  $L_P$  and  $L_S$ . Figure 15 shows the typical waveforms in normal operation.



**Figure 15. Primary and Secondary Side Current Waveforms**

## Startup Bias and UVLO

During startup, the TPS92310 is in the startup state. It is powered from the AC line through  $R_1$  and  $D_1$  (Figure 1). In the startup state, most of the internal circuits of the TPS92310 shut down so that the quiescent current is minimized. When  $V_{CC}$  (voltage on the VCC pin) reaches the rising threshold of the  $V_{CC-UVLO}$  (typically 25.6V), the TPS92310 is in the low frequency state, where  $t_{ON}$  and  $t_{OFF}$  are fixed to 1.5 $\mu$ s and 72 $\mu$ s. When  $V_{ZCD-PEAK}$  is higher than  $V_{ZCD-ARM}$ , the TPS92310 enters normal operation.

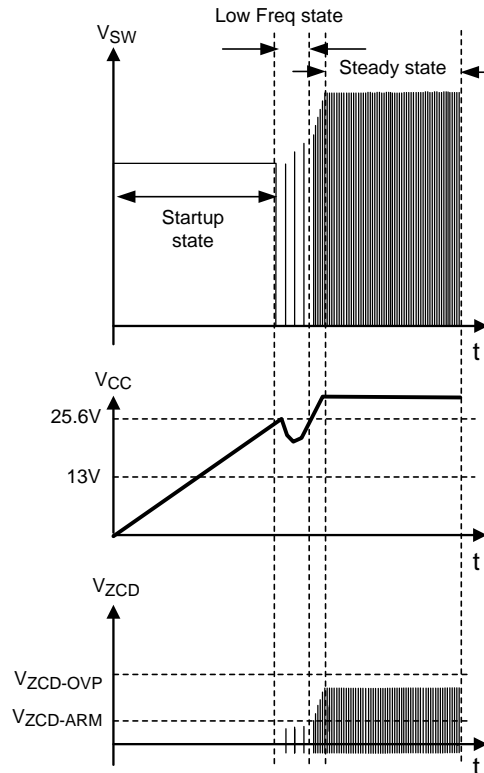

Figure 16. Start up Bias Waveforms

## Mode Decoder

The TPS92310 can operate in the Peak Current Mode (PCM) or Constant On-Time (COT) mode if an isolated topology is used. The TPS92310 can also use a non-isolated topology. In this case, only the COT mode can be selected. The COT mode gives a high power factor. The PCM can achieve a lower output current ripple. The COT mode using a non-isolated topology can achieve a higher efficiency and good load regulation. The above modes can be selected by setting the MODE1 and MODE2 pins according to Table 1. For normal operation of the TPS92310, the MODE1 and MODE2 pins cannot be connect to ground at the same time. And these pin were biased by an internal 1 $\mu$ A pull up, forcing any voltage into these pins are not allowed. The MODE decoder status will latch-in only when  $V_{CC}$  voltage reaches the  $V_{CC-UVLO}$  turn on threshold during start-up.

Table 1. MODE Configuration

MODE1	MODE2	Mode of operation
OPEN	OPEN	COT mode using isolated topology
GND	OPEN	PCM using isolated topology
OPEN	GND	COT mode using non-isolated topology
GND	GND	Reserved

### Zero Crossing Detection

To minimized the switching loss of the external MOSFET, a zero crossing detection circuit is embedded in the TPS92310.  $V_{LAUX}$  is AC voltage coupled from  $V_{SW}$  by means of the transformer, with the lower part of the waveform clipped by  $D_{ZCD}$ .  $V_{LAUX}$  is fed back to the ZCD pin to detect a zero crossing point through a resistor divider network which consists of  $R_2$  and  $R_3$ . The next turn on time of  $Q_1$  is selected  $V_{SW}$  is the minimum, an instant corresponding to a small delay after the zero crossing occurs. (Figure 17) The actual delay time depends on the drain capacitance of the  $Q_1$  and the primary inductance of the transformer ( $L_P$ ). Such delay time is set by a single external resistor as described in Delay Setting section.

During the off-period at steady state,  $V_{ZCD}$  reaches its maximum  $V_{ZCD-PEAK}$  (Figure 14), which is scalable by the turn ratio of the transformer and the resistor divider network  $R_2$  and  $R_3$ . It is recommended that  $V_{ZCD-PEAK}$  is set to 3V during normal operation.

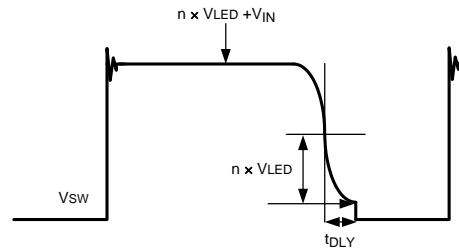

Figure 17. Switching Node Waveforms

### Delay Time Setting

In order to reduce EMI and switching loss, the TPS92310 can insert a delay between the off-period and the on-period. The delay time is set by a single resistor which connects across the DLY pin and ground, and their relationship is shown in Figure 18. The optimal delay time depends on the resonance frequency between  $L_P$  and the drain to source capacitance of  $Q_1$  ( $C_{DS}$ ). Circuit designers should optimize the delay time according to the following equation.

$$f_{SW} = \frac{1}{2\pi\sqrt{L_P C_{DS}}} \tag{1}$$

$$t_{DLY} = \frac{\pi\sqrt{L_P C_{DS}}}{2} \tag{2}$$

After determining the delay time,  $t_{DLY}$  can be implemented by setting  $R_{DLY}$  according to the following equation:

$$R_{DLY} = K_{DLY}(t_{DLY} - 105ns) \tag{3}$$

where  $K_{DLY} = 32M\Omega/ns$  is a constant.

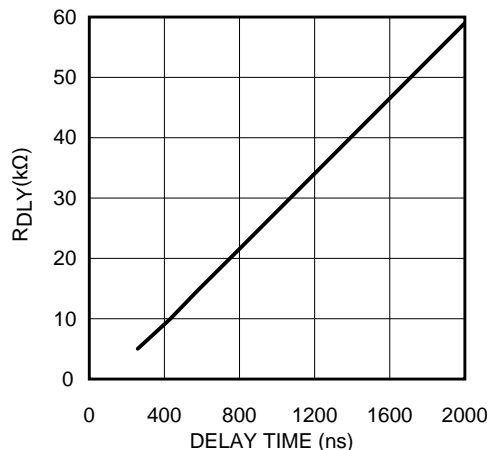

Figure 18. Delay Time Setting

## Protection Features

### Output Open Circuit Protection

If the LED string is disconnected,  $V_{LED}$  increases and thus  $V_{ZCD-PEAK}$  increases. When  $V_{ZCD-PEAK}$  is larger than  $V_{ZCD-OVP}$  for 3 continuous switching cycles, the Over Voltage Protection (OVP) feature is triggered such that the TPS92310 becomes Over-Voltage (OV) state. In this case, the switching of  $Q_1$  is stopped, and  $V_{CC}$  decreases owing to the power consumption of the internal circuits of the TPS92310. When  $V_{CC}$  drops below the falling threshold of  $V_{CC-UVLO}$ , the TPS92310 restarts, and re-enters into startup state (Figure 20).

### Output Short Circuit Protection

If the LED string is shorted,  $V_{ZCD-PEAK}$  drops. If  $V_{ZCD-PEAK}$  drops below  $V_{ZCD-TRIG}$ , the TPS92310 will enter low frequency operation. In this case, the power supplied from  $L_{AUX}$  is not enough to maintain  $V_{CC}$ , then  $V_{CC}$  decreases. If the short is removed during low frequency state, the TPS92310 will restore to steady state. If the short sustains till  $V_{CC}$  drops below the falling threshold of  $V_{CC-UVLO}$ , the TPS92310 restarts, and becomes startup state again. (Figure 19)

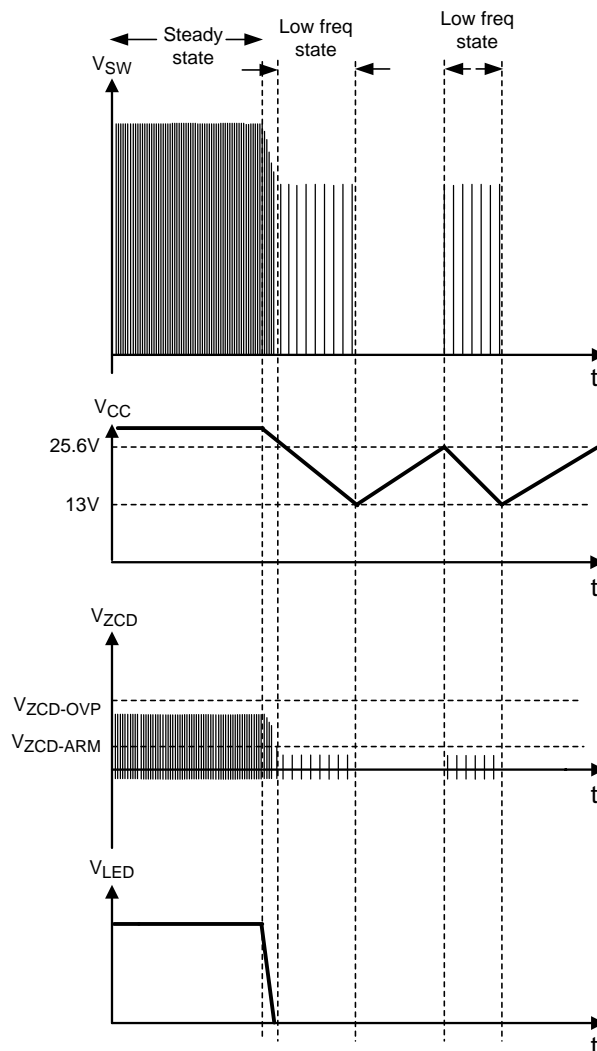

Figure 19. Output Short Circuit waveforms

### Over Current Protection

The Over Current Protection (OCP) limits the drain current of the external MOSFET Q1 and prevent inductor / transformer saturation. When  $V_{ISNS}$  reaches a threshold, the OCP is triggered and the output of the GATE pin is low immediately. The threshold is typically 3.4V and 0.64V when the TPS92310 is using an isolated topology and a non-isolated topology respectively.

### Thermal Protection

Thermal protection is implemented by an internal thermal shutdown circuit, which activates at 160°C (typically) to shut down the TPS92310. In this case, the GATE pin outputs low to turn off the external MOSFET, and hence no power from the VAUX winding to  $V_{CC}$ . Capacitor  $C_{VCC}$  will discharge until UVLO. When the junction temperature of the TPS92310 falls back below 130°C, the TPS92310 resumes normal operation.

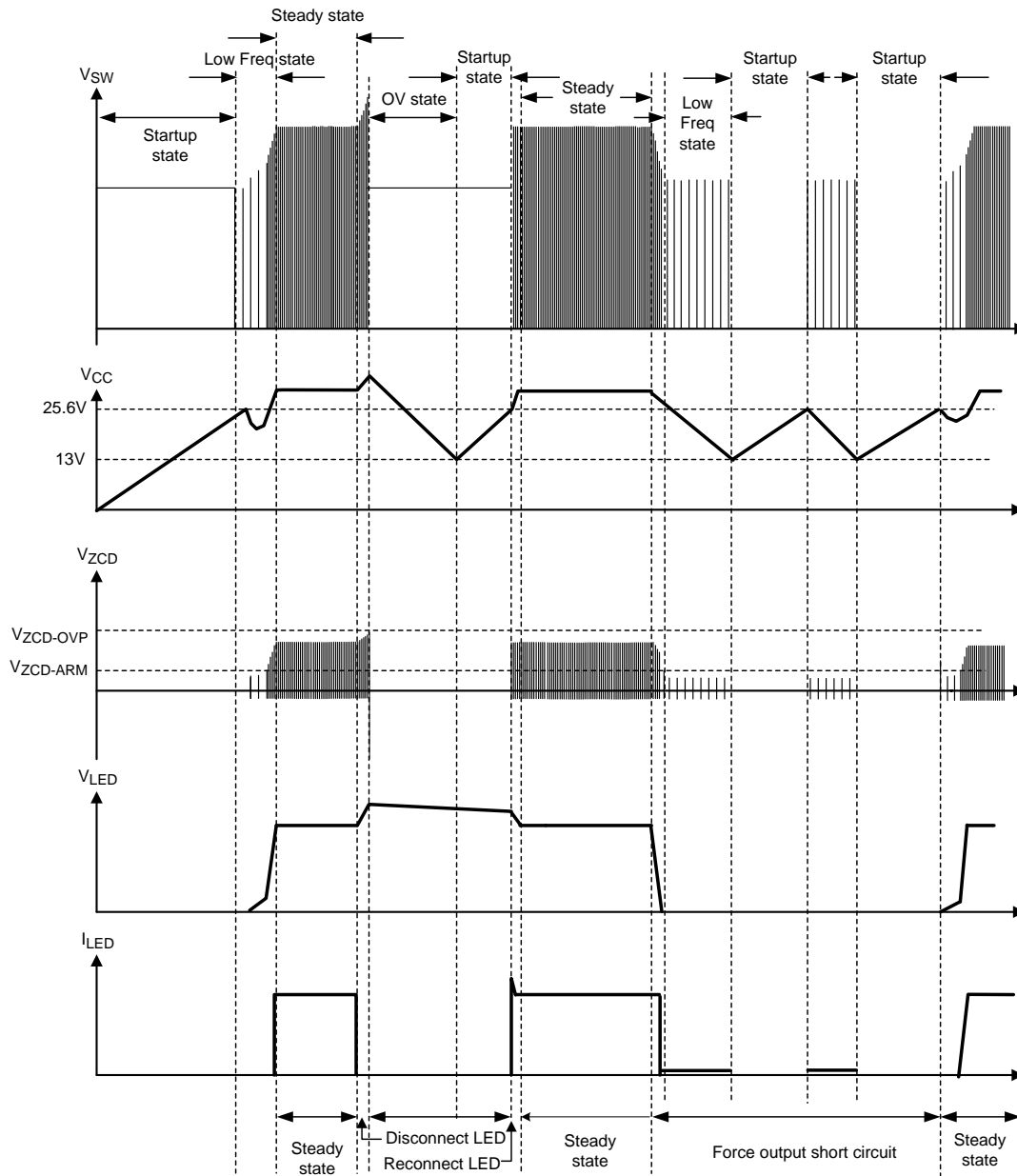

Figure 20. Auto Restart Operation

## Design Example

The following design example illustrates the procedures to calculate the external component values for the TPS92310 isolated single stage fly-back LED driver with PFC.

### Design Specifications:

Input voltage range,  $V_{AC\_RMS} = 85VAC - 132VAC$

Nominal input voltage,  $V_{AC\_RMS(NOM)} = 110VAC$

Number of LED in serial =7

LED current,  $I_{LED} = 350mA$

Forward voltage drop of single LED = 3.0V

Forward voltage of LED stack,  $V_{LED} = 21V$

### Key operating Parameters:

Converter minimum switching frequency,  $f_{SW} = 75kHz$

Output rectifier maximum reverse voltage,  $V_{D3(MAX)} = 100V$

Power MOSFET rating,  $V_{Q1(MAX)} = 800V (2.5A/3.8\Omega)$

Power MOSFET Output Capacitance,  $C_{DS} = 37pF$  (estimated)

Nominal output power,  $P_{OUT} = 8W$

### Start Up Bias resistor

During start up, the  $V_{CC}$  will be powered by the rectified line voltage through external resistor,  $R_1$ . The  $V_{CC}$  start up current,  $I_{VCC(SU)}$  must set in the range  $I_{VCC(MIN)} > I_{VCC(SU)} > I_{STARTUP(MAX)}$  to ensure proper restart operation during OVP fault. In this example, a value of 0.55mA is suggested. The resistance of  $R_1$  can be calculated by dividing the nominal input voltage in RMS by the start up current suggested.

So,  $R_1 = 110V/0.55mA = 200K\Omega$  is recommended.

### Transformer Turn Ratio

The transformer winding turn ratio,  $n$  is governed by the MOSFET Q1 maximum rated voltage, ( $V_{Q3(MAX)}$ ), highest line input peak voltage ( $V_{AC\_PEAK}$ ) and output diode maximum reverse voltage rating ( $V_{D3(MAX)}$ ). The output diode rating limits the lower bound of the turn ratio and the MOSFET rating provide the upper bound of the turn ratio. The transformer turn ratio must be selected in between the bounds. If the maximum reverse voltage of D3 ( $V_{D3(MAX)}$ ) is 100V. the minimum transformer turn ratio can be calculated with the equation in below.

$$n > \frac{V_{AC\_PEAK}}{(V_{D3(MAX)} - V_{LED})}$$

$$n > \frac{132 \times \sqrt{2}}{100 - 30} = 2.33 \quad (4)$$

In operation, the voltage at the switching node,  $V_{SW}$  must be small than the MOSFET maximum rated voltage  $V_{Q1(MAX)}$ , For reason of safety, 10% safety margin is recommended. Hence, 90% of  $V_{Q1(MAX)}$  is used in the following equation.

$$n < \frac{V_{Q1(MAX)} \times 0.9 - V_{AC\_PEAK} - V_{os}}{V_{LED(MAX)}} \quad (5)$$

$$n < \frac{600 \times 0.9 - 132 \sqrt{2} - 50}{30} = 12.1 \quad (6)$$

where  $V_{OS}$  is the maximum switching node overshoot voltage allowed, in this example, 50V is assumed. As a rule of thumb, lower turn ratio of transformer can provide a better line regulation and lower secondly side peak current. In here, turn ratio  $n = 3.8$  is recommended.

### Switching Frequency Selection

TPS92310 can operate at high switching frequency in the range of 60kHz to 150kHz. In most off-line applications, with considering of efficiency degradation and EMC requirements, the recommended switching frequency range will be 60kHz to 80kHz. In this design example, switching frequency at 75kHz is selected.

### Switching On Time

The maximum power switch on-time,  $t_{ON}$  depends on the low line condition of  $85V_{AC}$ . At  $85V_{AC}$  the switching frequency was chosen at 75kHz. This transformer design will follow the formulae as shown below.

$$t_{ON} = \frac{1}{f_{sw} \left( \frac{V_{AC\_MIN\_PEAK}}{n \times V_{LED}} + 1 \right)}$$

$$t_{ON} = \frac{1}{75000 \left( \frac{85\sqrt{2}}{3.8 \times 21} + 1 \right)} = 5.3\mu s \quad (7)$$

### Transformer Primary Inductance

The primary inductance,  $L_P$  of the transformer is related to the minimum operating switching frequency  $f_{sw}$ , converter output power  $P_{OUT}$ , system efficiency  $\eta$  and minimum input line voltage  $V_{AC\_RMS(MIN)}$ . For CRM operation, the output power,  $P_{OUT}$  can be described by the equation in below.

$$P_{OUT} = \eta \times \frac{1}{2} L_P \times I_{LP\_PEAK}^2 \times f_{sw} \quad (8)$$

By re-arranging terms, the transformer primary inductance required in this design example can be calculated with the equation follows:

$$L_P = \frac{\eta \times V_{AC\_RMS(MIN)}^2 \times t_{ON}^2}{2 \times P_{OUT} \times \frac{1}{f_{sw}}} \quad (9)$$

The converter minimum switching frequency is 75kHz,  $t_{ON}$  is 5.3 $\mu$ s,  $V_{AC\_RMS(MIN)} = 85V$  and  $P_{OUT} = 8W$ , assume the system efficiency,  $\eta = 85\%$ . Then,

$$L_P = \frac{0.85 \times (85)^2 \times (5.3\mu)^2}{2 \times 8 \times 13.3\mu} = 0.81mH \quad (10)$$

From the calculation in above, the inductance of the primary winding required is 0.81mH.

### Calculate The Current Sensing Resistor

After the primary inductance and transformer turn ratio is determined, the current sensing resistor,  $R_{ISNS}$  can be calculated.

The resistance for  $R_{ISNS}$  is governed by the output current and transformer turn ratio, the equation in below can be used.

$$R_{ISNS} = n \times \left( \frac{V_{REF}}{I_{LED}} \right) \quad (11)$$

where  $V_{REF}$  is fixed to 0.14V internally.

Transformer turn ratio,  $N_P : N_S$  is 3.8 : 1 and  $I_{LED} = 0.35A$

$$R_{ISNS} = 3.8 \times \frac{0.14}{0.35} = 1.52\Omega \quad (12)$$

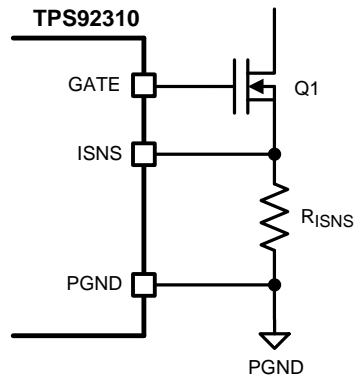

Figure 21.  $R_{ISNS}$  Resistor Interface

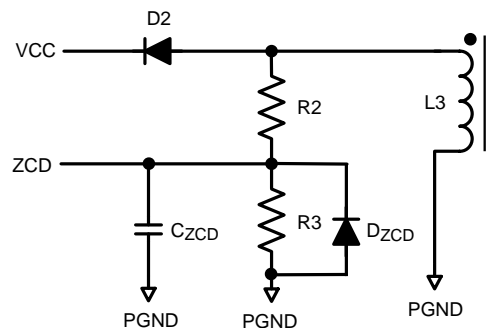

Figure 22. Auxiliary Winding Interface to ZCD

### Auxiliary Winding Interface To ZCD

In [Figure 22](#), R2 and R3 forms a resistor divider which sets the thresholds for over voltage protection of  $V_{LED}$ ,  $V_{ZCD-OVP}$ , and  $V_{ZCD-PEAK}$ . Before the calculation, we need to set the voltage of the auxiliary winding,  $V_{LAUX}$  at open circuit.

For example :

Assume the nominal forward voltage of LED stack ( $V_{LED}$ ) is 21V.

To avoid false triggering  $ZCD_{OVP}$  voltage threshold at normal operation, select  $ZCD_{OVP}$  voltage at 1.3 times of the  $V_{LED}$  is typical in most applications. In case the transformer leakage is higher, the  $ZCD_{OVP}$  threshold can be set to 1.5 times of the  $V_{LED}$ .

In this design example, open circuit AUX winding OVP voltage threshold is set to 30V. Assume the current through the AUX winding is 0.4mA typical.

As a result, R2 is 66k $\Omega$  and R3 is 11k $\Omega$ . Also, for suppressing high frequency noise at the ZCD pin, a 15pF capacitor connects the ZCD pin to ground is recommended.

### Auxiliary Winding $V_{CC}$ Diode Selection

The  $V_{CC}$  diode  $D_2$  provides the supply current to the controller, low temperature coefficient , low reverse leakage and ultra fast diode is recommended.

### Compensation Capacitor And Delay Timer Resistor Selection

To achieve PFC function with a constant on time flyback converter, a low frequency response loop is required. In most applications, a 2.2 $\mu$ F  $C_{COMP}$  capacitor is suitable for compensation.

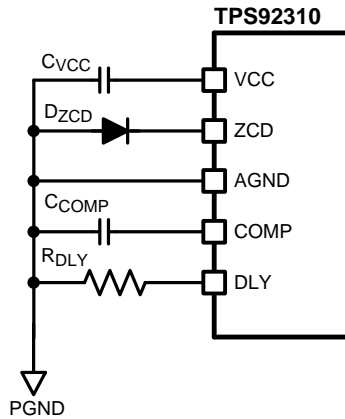

**Figure 23. Compensation and DLY Timer connection**

The resistor  $R_{DLY}$  connecting the DLY pin to ground is used to set the delay time between the ZCD trigger to gate turn on. The delay time required can be calculated with the parasitic capacitance at the drain of MOSFET to ground and primary inductance of the transformer. Equation in below can be used to find the delay time and [Figure 18](#) can help to find the resistance once the delay time is calculated

$$t_{DLY} = \frac{\pi \sqrt{L_P C_{DS}}}{2} \tag{13}$$

For example, using a transformer with primary inductance  $L_P = 1\text{mH}$ , and power MOSFET drain to ground capacitor  $C_{DS} = 37\text{pF}$ , the  $t_{DLY}$  can be calculated by the upper equation. As a result,  $t_{DLY} = 302\text{ns}$  and  $R_{DLY}$  is  $6.31\text{k}\Omega$ . The delay time may need to change according to the primary inductance of the transformer. The typical level of output current will shift if inappropriate delay time is chosen.

**Output Flywheel Diode Selection**

To increase the overall efficiency of the system, a low forward voltage schottky diode with appropriate rating should be used.

**Primary Side Snubber Design**

The leakage inductance can induce a high voltage spike when power MOSFET is turned off. [Figure 24](#) illustrate the operation waveform. A voltage clamp circuit is required to protect the MOSFET. The voltage of snubber clamp ( $V_{SN}$ ) must be higher than the sum of over shoot voltage ( $V_{OS}$ ), LED open load voltage multiplied by the transformer turn ratio ( $n$ ). In this examples, the  $V_{OS}$  is  $50\text{V}$  and LED maximum voltage,  $V_{LED(MAX)}$  is  $30\text{V}$ , transformer turn ratio is  $3.8$ . The snubber voltage required can be calculated with following equations.

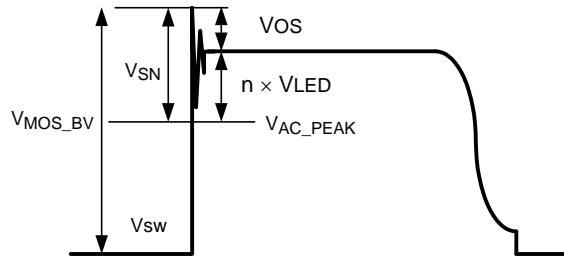

**Figure 24. Snubber Waveform**

$$V_{SN} > V_{OS} + V_{LED(MAX)} \times n \tag{14}$$

where  $n$  is the turn ratio of the transformer.

$$V_{SN} > 50\text{V} + 30\text{V} \times 3.8 = 154\text{V} \tag{15}$$

At the same time, sum of the snubber clamp voltage and  $V_{AC\_PEAK}$  must be smaller than the MOSFET breakdown voltage ( $V_{MOS\_BV}$ ). By re-arranging terms, equation in below can be used.

$$V_{SN} < V_{MOS\_BV} - V_{AC} \sqrt{2}$$

$$V_{SN} < 800 - 132 \times \sqrt{2} = 614V$$

(16)

In here, snubber clamp voltage,  $V_{SN} = 250V$  is recommended.

### Output Capacitor

The capacitance of the output capacitor is determined by the equivalent series resistance (ESR) of the LED,  $R_{LED}$  and the ripple current allowed for the application. The equation in below can be used to calculate the required capacitance.

$$C_{OUT} = \frac{\sqrt{\left(2 \frac{I_{LED}}{\Delta I_{LED}}\right)^2 - 1}}{4 \times \pi \times f_{AC} R_{LED}}$$

(17)

Assume the ESR of the LED stack contains 7 LEDs and is  $2.6\Omega$ , AC line frequency  $f_{AC}$  is 60Hz.

In this example, LED current  $I_{LED}$  is 350mA and output ripple current is 30% of  $I_{LED}$ :

$$C_{OUT} = \frac{\sqrt{\left(\frac{2 \times 0.35}{0.3 \times 0.35}\right)^2 - 1}}{4 \times \pi \times 60 \times 7 \times 2.6}$$

(18)

Then,  $C_{OUT} = 480\mu F$ .

In here, a  $470\mu F$  output capacitor with  $10\mu F$  ceramic capacitor in parallel is suggested.

### PCB Layout Considerations

The performance of any switching power supplies depend as much upon the layout of the PCB as the component selection. Good layout practices are important when constructing the PCB. The layout must be as neat and compact as possible, and all external components must be as close as possible to their associated pins. High current return paths and signal return paths must be separated and connect together at single ground point. All high current connections must be as short and direct as possible with thick traces. The gate pin of the switching MOSFET should be connected close to the GATE pin with short and thick trace to reduce potential electro-magnetic interference. For off-line applications, one more consideration is the safety requirements. The clearance and creepage to high voltage traces must be complied to all applicable safety regulations.

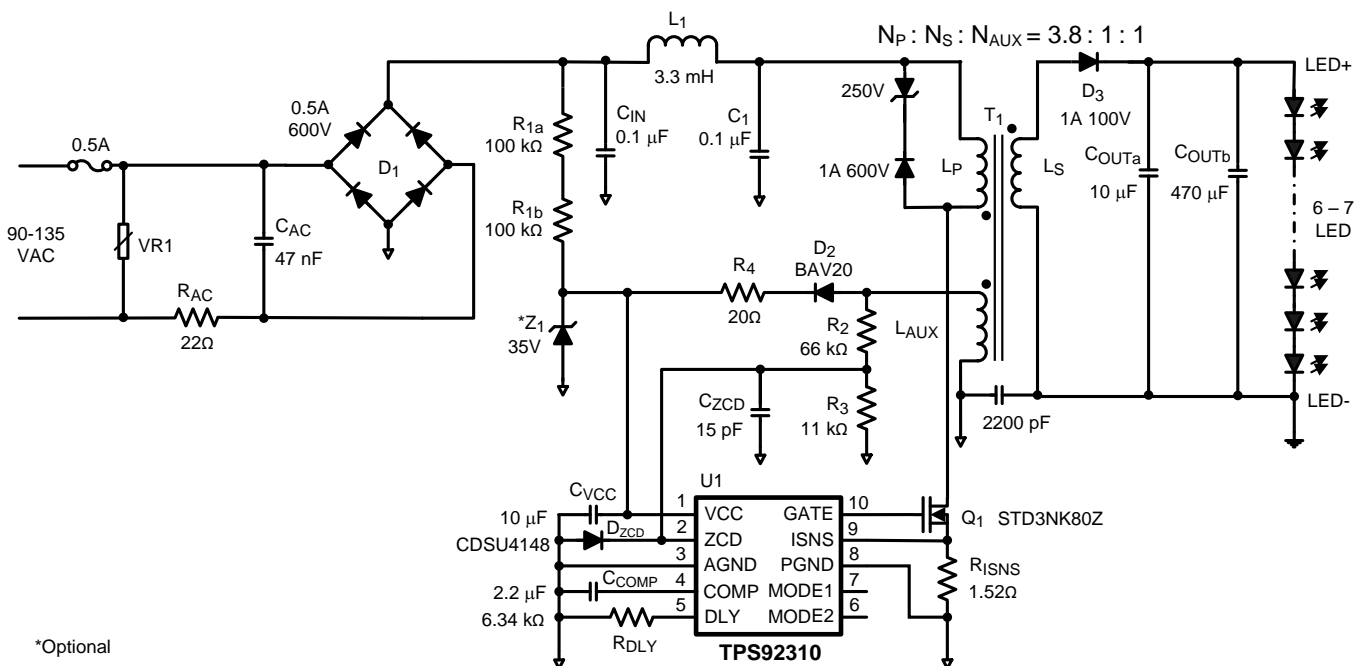

Figure 25. Isolated topology schematic

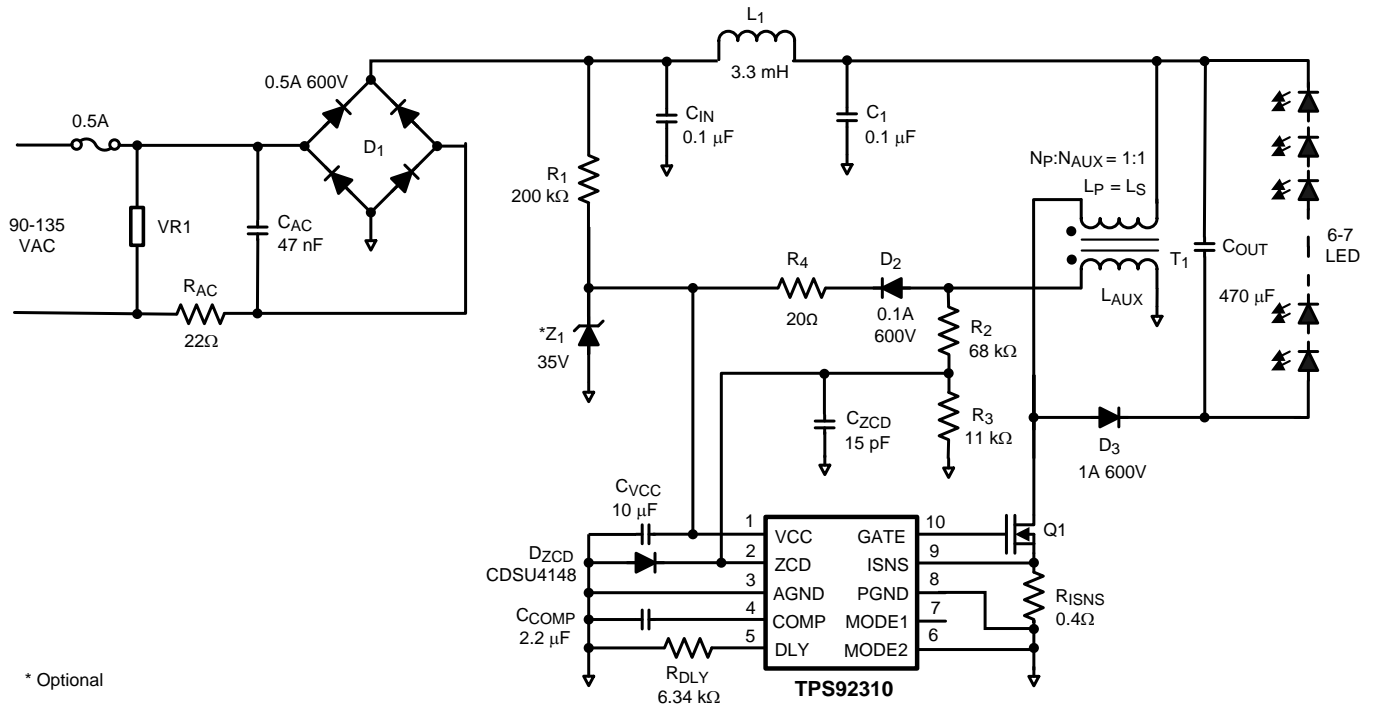

Figure 26. Non-isolated topology schematic

**PACKAGING INFORMATION**

Orderable Device	Status (1)	Package Type	Package Drawing	Pins	Package Qty	Eco Plan (2)	Lead finish/ Ball material (6)	MSL Peak Temp (3)	Op Temp (°C)	Device Marking (4/5)	Samples
TPS92310DGS/NOPB	ACTIVE	VSSOP	DGS	10	1000	RoHS & Green	SN	Level-1-260C-UNLIM	-40 to 125	SL1B	<b>Samples</b>
TPS92310DGSR/NOPB	ACTIVE	VSSOP	DGS	10	3500	RoHS & Green	SN	Level-1-260C-UNLIM	-40 to 125	SL1B	<b>Samples</b>

(1) The marketing status values are defined as follows:

**ACTIVE:** Product device recommended for new designs.

**LIFEBUY:** TI has announced that the device will be discontinued, and a lifetime-buy period is in effect.

**NRND:** Not recommended for new designs. Device is in production to support existing customers, but TI does not recommend using this part in a new design.

**PREVIEW:** Device has been announced but is not in production. Samples may or may not be available.

**OBSOLETE:** TI has discontinued the production of the device.

(2) **RoHS:** TI defines "RoHS" to mean semiconductor products that are compliant with the current EU RoHS requirements for all 10 RoHS substances, including the requirement that RoHS substance do not exceed 0.1% by weight in homogeneous materials. Where designed to be soldered at high temperatures, "RoHS" products are suitable for use in specified lead-free processes. TI may reference these types of products as "Pb-Free".

**RoHS Exempt:** TI defines "RoHS Exempt" to mean products that contain lead but are compliant with EU RoHS pursuant to a specific EU RoHS exemption.

**Green:** TI defines "Green" to mean the content of Chlorine (Cl) and Bromine (Br) based flame retardants meet JS709B low halogen requirements of <=1000ppm threshold. Antimony trioxide based flame retardants must also meet the <=1000ppm threshold requirement.

(3) MSL, Peak Temp. - The Moisture Sensitivity Level rating according to the JEDEC industry standard classifications, and peak solder temperature.

(4) There may be additional marking, which relates to the logo, the lot trace code information, or the environmental category on the device.

(5) Multiple Device Markings will be inside parentheses. Only one Device Marking contained in parentheses and separated by a "~" will appear on a device. If a line is indented then it is a continuation of the previous line and the two combined represent the entire Device Marking for that device.

(6) Lead finish/Ball material - Orderable Devices may have multiple material finish options. Finish options are separated by a vertical ruled line. Lead finish/Ball material values may wrap to two lines if the finish value exceeds the maximum column width.

**Important Information and Disclaimer:**The information provided on this page represents TI's knowledge and belief as of the date that it is provided. TI bases its knowledge and belief on information provided by third parties, and makes no representation or warranty as to the accuracy of such information. Efforts are underway to better integrate information from third parties. TI has taken and continues to take reasonable steps to provide representative and accurate information but may not have conducted destructive testing or chemical analysis on incoming materials and chemicals. TI and TI suppliers consider certain information to be proprietary, and thus CAS numbers and other limited information may not be available for release.

In no event shall TI's liability arising out of such information exceed the total purchase price of the TI part(s) at issue in this document sold by TI to Customer on an annual basis.



**TAPE AND REEL INFORMATION**

**QUADRANT ASSIGNMENTS FOR PIN 1 ORIENTATION IN TAPE**

\*All dimensions are nominal

Device	Package Type	Package Drawing	Pins	SPQ	Reel Diameter (mm)	Reel Width W1 (mm)	A0 (mm)	B0 (mm)	K0 (mm)	P1 (mm)	W (mm)	Pin1 Quadrant
TPS92310DGS/NOPB	VSSOP	DGS	10	1000	178.0	12.4	5.3	3.4	1.4	8.0	12.0	Q1
TPS92310DGSR/NOPB	VSSOP	DGS	10	3500	330.0	12.4	5.3	3.4	1.4	8.0	12.0	Q1

**TAPE AND REEL BOX DIMENSIONS**

\*All dimensions are nominal

Device	Package Type	Package Drawing	Pins	SPQ	Length (mm)	Width (mm)	Height (mm)
TPS92310DGS/NOPB	VSSOP	DGS	10	1000	208.0	191.0	35.0
TPS92310DGSR/NOPB	VSSOP	DGS	10	3500	367.0	367.0	35.0

# DGS0010A



# PACKAGE OUTLINE

## VSSOP - 1.1 mm max height

SMALL OUTLINE PACKAGE



### NOTES:

1. All linear dimensions are in millimeters. Any dimensions in parenthesis are for reference only. Dimensioning and tolerancing per ASME Y14.5M.
2. This drawing is subject to change without notice.
3. This dimension does not include mold flash, protrusions, or gate burrs. Mold flash, protrusions, or gate burrs shall not exceed 0.15 mm per side.
4. This dimension does not include interlead flash. Interlead flash shall not exceed 0.25 mm per side.
5. Reference JEDEC registration MO-187, variation BA.

# EXAMPLE BOARD LAYOUT

DGS0010A

VSSOP - 1.1 mm max height

SMALL OUTLINE PACKAGE



LAND PATTERN EXAMPLE  
SCALE:10X

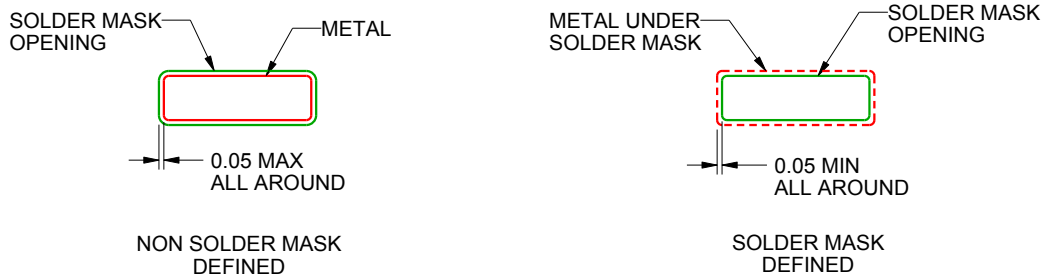

SOLDER MASK DETAILS  
NOT TO SCALE

4221984/A 05/2015

NOTES: (continued)

6. Publication IPC-7351 may have alternate designs.
7. Solder mask tolerances between and around signal pads can vary based on board fabrication site.

# EXAMPLE STENCIL DESIGN

DGS0010A

VSSOP - 1.1 mm max height

SMALL OUTLINE PACKAGE



SOLDER PASTE EXAMPLE  
BASED ON 0.125 mm THICK STENCIL  
SCALE:10X

4221984/A 05/2015

NOTES: (continued)

8. Laser cutting apertures with trapezoidal walls and rounded corners may offer better paste release. IPC-7525 may have alternate design recommendations.
9. Board assembly site may have different recommendations for stencil design.

## IMPORTANT NOTICE AND DISCLAIMER

TI PROVIDES TECHNICAL AND RELIABILITY DATA (INCLUDING DATA SHEETS), DESIGN RESOURCES (INCLUDING REFERENCE DESIGNS), APPLICATION OR OTHER DESIGN ADVICE, WEB TOOLS, SAFETY INFORMATION, AND OTHER RESOURCES "AS IS" AND WITH ALL FAULTS, AND DISCLAIMS ALL WARRANTIES, EXPRESS AND IMPLIED, INCLUDING WITHOUT LIMITATION ANY IMPLIED WARRANTIES OF MERCHANTABILITY, FITNESS FOR A PARTICULAR PURPOSE OR NON-INFRINGEMENT OF THIRD PARTY INTELLECTUAL PROPERTY RIGHTS.

These resources are intended for skilled developers designing with TI products. You are solely responsible for (1) selecting the appropriate TI products for your application, (2) designing, validating and testing your application, and (3) ensuring your application meets applicable standards, and any other safety, security, regulatory or other requirements.

These resources are subject to change without notice. TI grants you permission to use these resources only for development of an application that uses the TI products described in the resource. Other reproduction and display of these resources is prohibited. No license is granted to any other TI intellectual property right or to any third party intellectual property right. TI disclaims responsibility for, and you will fully indemnify TI and its representatives against, any claims, damages, costs, losses, and liabilities arising out of your use of these resources.

TI's products are provided subject to [TI's Terms of Sale](#) or other applicable terms available either on [ti.com](http://ti.com) or provided in conjunction with such TI products. TI's provision of these resources does not expand or otherwise alter TI's applicable warranties or warranty disclaimers for TI products.

TI objects to and rejects any additional or different terms you may have proposed.

Mailing Address: Texas Instruments, Post Office Box 655303, Dallas, Texas 75265  
Copyright © 2021, Texas Instruments Incorporated