

# TLIN2022A-Q1 具有显性状态超时的双路本地互连网络 (LIN) 收发器

## 1 特性

- 符合面向汽车应用的 AEC-Q100 (1 级) 标准
- 符合 LIN 2.0、LIN 2.1、LIN 2.2、LIN 2.2 A 和 ISO/DIS 17987 - 4 电气物理层 (EPL) 规格标准
- 符合面向汽车应用的 SAE J2602-1 LIN 网络标准
- 提供功能安全
  - 可帮助进行功能安全系统设计的文档
- 支持 12V 和 24V 电池应用
- LIN 传输数据速率高达 20kbps
- LIN 接收数据速率高达 100kbps
- 宽工作电源电压范围：4V 至 48V
- 休眠模式：超低电流消耗允许以下类型的唤醒事件：
  - LIN 总线
  - 通过 EN 引脚的本地唤醒
- 在 LIN 总线和 RXD 输出上实现上电和断电无干扰运行
- 保护特性：
  - ±60V LIN 总线容错
  - V<sub>SUP</sub> 欠压保护
  - TXD 显性超时 (DTO) 保护
  - 热关断保护
  - 系统级未供电节点或接地断开失效防护。
- 可提供具有可湿性侧面的 SOIC (14) 和无引线 VSON (14) 封装

## 2 应用

- 车身电子装置和照明
- 混合动力电动汽车和动力总成系统
- 信息娱乐系统与仪表组
- 电器

## 3 说明

TLIN2022A-Q1 是一款双路本地互连网络 (LIN) 物理层收发器，集成了唤醒和保护功能，符合 LIN 2.0、LIN 2.1、LIN 2.2、LIN 2.2A 和 ISO/DIS 17987 - 4 标准。LIN 是一根单线制双向总线，通常用于低速车载网络，数据传输速率高达 20kbps。TLIN2022A-Q1 旨在为 12V 和 24V 应用提供支持，具有更宽的工作电压范围和额外的总线故障保护。

LIN 接收器支持高达 100kbps 的数据传输速率，从而更快地执行内联编程 TLIN2022A-Q1 使用一个可降低电磁辐射 (EME) 的限流波形整形驱动器将 TXD 输入上的 LIN 协议数据流转化为 LIN 总线信号。接收器将数据流转化为逻辑电平信号，此信号通过开漏 RXD 引脚发送到微处理器。休眠模式可实现超低电流消耗，该模式允许通过 LIN 总线或 EN 引脚实现唤醒。

### 器件信息

器件型号	封装 <sup>(1)</sup>	封装尺寸 (标称值)
TLIN2022A-Q1	SOIC (14) (D)	5.00mm x 8.65mm
	VSON (14) (DMT)	3.00mm x 4.50mm

(1) 如需了解所有可用封装，请参阅数据表末尾的可订购产品附录。

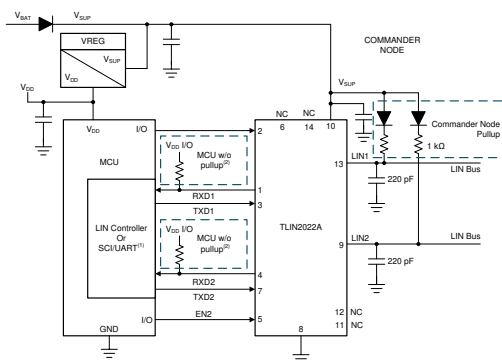

简化版原理图，指挥官模式

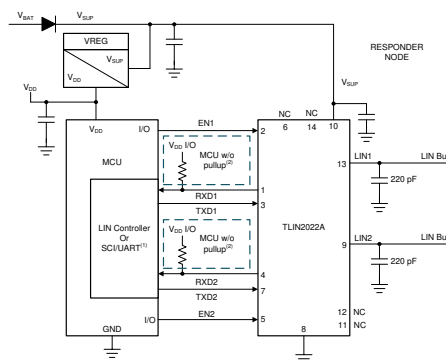

简化版原理图，响应者模式



## Table of Contents

<b>1 特性</b> .....	1	9.2 Functional Block Diagram.....	23
<b>2 应用</b> .....	1	9.3 Feature Description.....	23
<b>3 说明</b> .....	1	9.4 Device Functional Modes.....	26
<b>4 说明 (续)</b> .....	3	<b>10 Application Information Disclaimer</b> .....	29
<b>5 Revision History</b> .....	3	10.1 Application Information.....	29
<b>6 Pin Configuration and Functions</b> .....	4	10.2 Typical Application.....	29
<b>7 Specifications</b> .....	5	<b>11 Layout</b> .....	32
7.1 Absolute Maximum Ratings .....	5	11.1 Layout Guidelines.....	32
7.2 ESD Ratings .....	5	11.2 Layout Example.....	33
7.3 ESD Ratings - IEC .....	5	<b>12 Device and Documentation Support</b> .....	34
7.4 Thermal Information .....	6	12.1 Documentation Support.....	34
7.5 Recommended Operating Conditions .....	6	12.2 接收文档更新通知.....	34
7.6 Electrical Characteristics .....	7	12.3 支持资源.....	34
7.7 Duty Cycle Characteristics .....	9	12.4 Trademarks.....	34
7.8 Switching Characteristics .....	11	12.5 Electrostatic Discharge Caution.....	35
7.9 Typical Characteristics.....	12	12.6 Glossary.....	35
<b>8 Parameter Measurement Information</b> .....	14	<b>13 Mechanical, Packaging, and Orderable Information</b> .....	35
<b>9 Detailed Description</b> .....	22		
9.1 Overview.....	22		

## 4 说明 (续)

TLIN2022A-Q1 集成了一个用于 LIN 响应节点应用、ESD 保护和故障保护的电阻器，可减少应用中的外部元件数量。一旦发生接地漂移或电源电压断开，该器件可防止反馈电流经 LIN 流向电源输入。器件还包含欠压保护、过热关断保护和接地失效保护功能。

## 5 Revision History

注：以前版本的页码可能与当前版本的页码不同

DATE	REVISION	NOTES
June 2021	*	Initial release

## 6 Pin Configuration and Functions



图 6-1. D Package, 14-Pin (SOIC), Top View



图 6-2. DMT Package, 14-Pin (VSON), Top View

表 6-1. Pin Functions

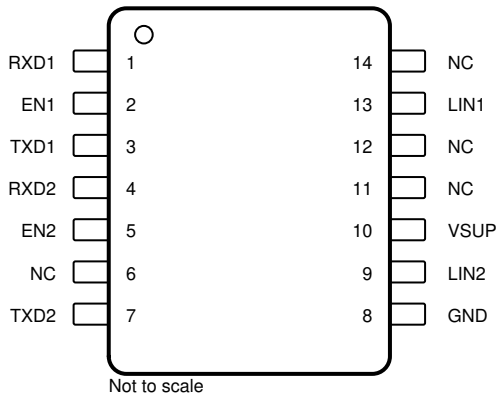
PIN		Type	DESCRIPTION
NO.	NAME		
1	RXD1	O	Channel 1 RXD Output (open-drain) interface reporting state of LIN bus voltage
2	EN1	I	Channel 1 Enable Input- High puts the channel 1 in normal operation mode and low puts it in sleep mode
3	TXD1	I	Channel 1 TXD input interface to control state of LIN output
4	RXD2	O	Channel 2 RXD Output (open-drain) interface reporting state of LIN bus voltage
5	EN2	I	Channel 2 Enable Input- High puts the channel 2 in normal operation mode and low puts it in sleep mode
7	TXD2	I	Channel 2 TXD input interface to control state of LIN output
8	GND	GND	Ground
9	LIN2	HV I/O	Channel 2 High voltage LIN bus single-wire transmitter and receiver
10	V <sub>SUP</sub>	Supply	Device Supply Voltage (connected to battery in series with external reverse blocking diode)
13	LIN1	HV I/O	Channel 1 High voltage LIN bus single-wire transmitter and receiver
6, 11, 12, 14	NC	-	Not Connected
Thermal Pad		-	Can be connected to the PCB ground plane to improve thermal coupling (DMT package only)

## 7 Specifications

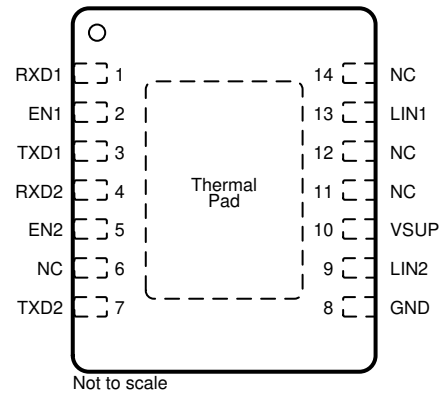
### 7.1 Absolute Maximum Ratings

(1) (2)

Symbol	Parameter	MIN	MAX	UNIT
V <sub>SUP</sub>	Supply voltage range (ISO/DIS 17987 Param 10)	- 0.3	60	V
V <sub>LIN</sub>	LIN bus input voltage (ISO/DIS 17987 Param 82)	- 60	60	V
V <sub>LOGIC</sub>	Logic pin voltage (RXD, TXD, EN)	- 0.3	6	V
I <sub>O</sub>	Logic pin output current		8	mA
T <sub>J</sub>	Junction temperature range	- 55	150	°C

- (1) Stresses beyond those listed under Absolute Maximum Ratings may cause permanent damage to the device. These are stress ratings only, which do not imply functional operation of the device at these or any other conditions beyond those indicated under Recommended Operating Conditions. Exposure to absolute-maximum-rated conditions for extended periods may affect device reliability.
- (2) All voltage values are with respect to ground terminal.

### 7.2 ESD Ratings

ESD Ratings			VALUE	UNIT
V <sub>(ESD)</sub>	Electrostatic discharge	Human body model (HBM) classification level 3A: TXD, RXD, EN Pins, per AEC Q100-002 <sup>(1)</sup>	±4000	V
		Human body model (HBM) classification level 3B: LIN and V <sub>SUP</sub> Pin with respect to ground	±8000	
		Charged device model (CDM) classification level C5, per AEC Q100-011	All pins ±1500	

- (1) AEC Q100-002 indicates that HBM stressing shall be in accordance with the ANSI/ESDA/JEDEC JS-001 specification.

### 7.3 ESD Ratings - IEC

ESD and Surge Protection Ratings			VALUE	UNIT
V <sub>(ESD)</sub>	Electrostatic discharge, LIN, V <sub>SUP</sub> to GND <sup>(1)</sup>	IEC 62228-2 per ISO 10605 Contact discharge R = 330 Ω, C = 150 pF	±8000	V

### 7.3 ESD Ratings - IEC (continued)

ESD and Surge Protection Ratings		VALUE	UNIT	
V <sub>TRAN</sub>	ISO 7637-2 and IEC 62228-2 per IEC 62215-3 transients according to IBEE LIN EMC test specifications <sup>(2)</sup> (LIN, V <sub>SUP</sub> to GND)	IEC 62228-2 per IEC 62215-3 12 V electrical systems Pulse 1	- 100	V
		IEC 62215-3 24 V electrical systems <sup>(2)</sup> Pulse 1	- 450	
		IEC 62228-2 per IEC 62215-3 12 V electrical systems 24 V electrical systems <sup>(2)</sup> Pulse 2	75	
		IEC 62228-2 per IEC 62215-3 12 V electrical systems Pulse 3a	- 150	
		IEC 62215-3 24 V electrical systems <sup>(2)</sup> Pulse 3a	-225	
		IEC 62228-2 per IEC 62215-3 12 V electrical systems Pulse 3b	100	
		IEC 62215-3 24 V electrical systems <sup>(2)</sup> Pulse 3b	225	

- (1) Results given here are specific to the IEC 62228-2 Integrated circuits - EMC evaluation of transceivers - Part 2: LIN transceivers. Testing performed by OEM approved independent 3rd party, EMC report available upon request.
- (2) Verified during characterization

### 7.4 Thermal Information

THERMAL METRIC <sup>(1)</sup>		TLIN2022AD-Q1	TLIN2022ADMT-Q1	UNIT
		D (SOIC)	DMT (VSON)	
		14-PINS	14-PINS	
R <sub>θJA</sub>	Junction-to-ambient thermal resistance	82.3	35.5	°C/W
R <sub>θJC(top)</sub>	Junction-to-case (top) thermal resistance	41.5	18.1	°C/W
R <sub>θJB</sub>	Junction-to-board thermal resistance	38.4	13.1	°C/W
Ψ <sub>JT</sub>	Junction-to-top characterization parameter	8.9	0.6	°C/W
Ψ <sub>JB</sub>	Junction-to-board characterization parameter	38.1	13.1	°C/W
R <sub>θJC(bot)</sub>	Junction-to-case (bottom) thermal resistance	n/a	2.5	°C/W

- (1) For more information about traditional and new thermal metrics, see the Semiconductor and IC Package Thermal Metrics application report, SPRA953.

### 7.5 Recommended Operating Conditions

parameters valid across -40°C ≤ T<sub>A</sub> ≤ 125°C (unless otherwise noted)

PARAMETER - DEFINITION		MIN	NOM	MAX	UNIT
V <sub>SUP</sub>	Supply voltage	4		48	V
V <sub>LIN</sub>	LIN Bus input voltage	0		48	V
V <sub>LOGIC</sub>	Logic Pin Voltage (RXD, TXD, EN)	0		5.25	V
T <sub>A</sub>	Ambient temperature range	-40		125	°C
TSD	Thermal shutdown edge	165			°C
TSD <sub>(HYS)</sub>	Thermal shutdown hysteresis		15		°C

## 7.6 Electrical Characteristics

parameters valid across  $-40^{\circ}\text{C} \leq T_A \leq 125^{\circ}\text{C}$  (unless otherwise noted)

PARAMETER		TEST CONDITIONS	MIN	TYP	MAX	UNIT
<b>Power Supply</b>						
$V_{\text{SUP}}$	Operational supply voltage (ISO/DIS 17987 Param 10, 53)	Device is operational beyond the LIN defined nominal supply voltage range See <a href="#">Figure 8-1</a> and <a href="#">Figure 8-2</a>	4		48	V
$V_{\text{SUP}}$	Nominal supply voltage (ISO/DIS 17987 Param 10, 53)	Normal and Standby Modes: ramp $V_{\text{SUP}}$ while LIN signal is a 10 kHz square wave with 50 % duty cycle and 36V swing. See <a href="#">Figure 8-1</a> and <a href="#">Figure 8-2</a>	4		48	V
		Sleep Mode	4		48	V
$UV_{\text{SUP}}$	Undervoltage $V_{\text{SUP}}$ threshold		2.9		3.85	V
$UV_{\text{HYS}}$	Delta hysteresis voltage for $V_{\text{SUP}}$ undervoltage threshold			0.2		V
$I_{\text{SUP}}$	Supply current	Normal Mode: EN = High, bus dominant: total bus load where $R_{\text{LIN}} > 500 \Omega$ and $C_{\text{LIN}} < 10 \text{ nF}$		1.2	8.5	mA
		Standby Mode: EN = Low, bus dominant: total bus load where $R_{\text{LIN}} > 500 \Omega$ and $C_{\text{LIN}} < 10 \text{ nF}$		1.1	3.75	mA
$I_{\text{SUP}}$	Supply current	Normal Mode: EN = High, Bus Recessive: LIN = $V_{\text{SUP}}$		670	1600	$\mu\text{A}$
		Standby Mode: EN = Low, Bus Recessive LIN = $V_{\text{SUP}}$		20	40	$\mu\text{A}$
		Sleep Mode: $4.0 \text{ V} < V_{\text{SUP}} < 14 \text{ V}$ , LIN = $V_{\text{SUP}}$ , EN = 0 V, TXD and RXD Floating		10	20	$\mu\text{A}$
		Sleep Mode: $14 \text{ V} < V_{\text{SUP}} < 36 \text{ V}$ , LIN = $V_{\text{SUP}}$ , EN = 0 V, TXD and RXD floating			30	$\mu\text{A}$
<b>RXD1/RXD2 OUTPUT PIN (OPEN DRAIN)</b>						
$V_{\text{OL}}$	Output Low voltage	Based upon external pull-up to $V_{\text{CC}}$ <sup>(4)</sup>			0.6	V
$I_{\text{OL}}$	Low-level output current, open-drain	LIN = 0 V, RXD = 0.4 V	1.5			mA
$I_{\text{ILG}}$	Leakage current, high-level	LIN = $V_{\text{SUP}}$ , RXD = 5 V	- 5	0	5	$\mu\text{A}$
<b>TXD1/TXD2 INPUT PIN</b>						
$V_{\text{IL}}$	Low-level input voltage		- 0.3		0.8	V
$V_{\text{IH}}$	High-level input voltage		2		5.25	V
$V_{\text{HYS}}$	Input threshold voltage, normal modes & selective wake modes			50	500	mV
$I_{\text{ILG}}$	Low-level input leakage current	TXD = Low	- 5	0	5	$\mu\text{A}$
$R_{\text{TXD}}$	Internal pull-down resistor value		125	350	800	k $\Omega$
<b>EN1/EN2 INPUT PIN</b>						
$V_{\text{IL}}$	Low-level input voltage		- 0.3		0.8	V
$V_{\text{IH}}$	High-level input voltage		2		5.25	V
$V_{\text{HYS}}$	Hysteresis voltage	By design and characterization		50	500	mV
$I_{\text{ILG}}$	Low-level input current	EN = Low	- 5	0	5	$\mu\text{A}$
$R_{\text{EN}}$	Internal pull-down resistor		125	350	800	k $\Omega$
<b>LIN1/LIN2 PIN</b>						
$V_{\text{OH}}$	HIGH level output voltage <sup>(3)</sup>	LIN recessive, TXD = high, $I_{\text{O}} = 0 \text{ mA}$ , $7 \text{ V} \leq V_{\text{SUP}} \leq 48 \text{ V}$	0.85			$V_{\text{SUP}}$
$V_{\text{OH}}$	LIN recessive high-level output voltage <sup>(1) (2)</sup>	TXD = high, $I_{\text{O}} = 0 \text{ mA}$ , $7 \text{ V} \leq V_{\text{SUP}} \leq 18 \text{ V}$	0.8			$V_{\text{SUP}}$

## 7.6 Electrical Characteristics (continued)

parameters valid across  $-40^{\circ}\text{C} \leq T_A \leq 125^{\circ}\text{C}$  (unless otherwise noted)

PARAMETER		TEST CONDITIONS	MIN	TYP	MAX	UNIT
V <sub>OH</sub>	HIGH level output voltage <sup>(3)</sup>	LIN recessive, TXD = high, I <sub>O</sub> = 0 mA, 4 V ≤ V <sub>SUP</sub> < 7 V	3			V
V <sub>OL</sub>	LOW level output voltage <sup>(3)</sup>	LIN dominant, TXD = low, 7 V ≤ V <sub>SUP</sub> ≤ 48 V			0.2	V <sub>SUP</sub>
V <sub>OL</sub>	LIN dominant low-level output voltage <sup>(1) (2)</sup>	TXD = low, 7 V ≤ V <sub>SUP</sub> ≤ 18 V			0.2	V <sub>SUP</sub>
V <sub>OL</sub>	LOW level output voltage <sup>(3)</sup>	LIN dominant, TXD = low, 4 V ≤ V <sub>SUP</sub> < 7 V			1.2	V
V <sub>SUP_NON_OP</sub>	V <sub>SUP</sub> where impact of recessive LIN bus < 5% (ISO/DIS 17987 Param 56)	TXD & RXD open LIN = 4 V to 58 V	- 0.3		58	V
I <sub>BUS_LIM</sub>	Limiting current (ISO/DIS 17987 Param 57)	TXD = 0 V, V <sub>LIN</sub> = 48 V, R <sub>MEAS</sub> = 440 Ω, V <sub>SUP</sub> = 48 V, V <sub>BUSdom</sub> < 4.518 V	75	120	300	mA
I <sub>BUS_PAS_dom</sub>	Receiver leakage current, dominant (ISO/DIS 17987 Param 58)	LIN = 0 V, V <sub>SUP</sub> = 24 V Driver off/recessive; See <a href="#">Figure 8-6</a>	- 2			mA
I <sub>BUS_PAS_rec1</sub>	Receiver leakage current, recessive (ISO/DIS 17987 Param 59)	LIN > V <sub>SUP</sub> , 8 V ≤ V <sub>SUP</sub> ≤ 48 V Driver off; See <a href="#">Figure 8-7</a>			20	μA
I <sub>BUS_PAS_rec2</sub>	Receiver leakage current, recessive (ISO/DIS 17987 Param 59)	LIN = V <sub>SUP</sub> , Driver off; See <a href="#">Figure 8-7</a>	- 5		5	μA
I <sub>BUS_NO_GND</sub>	Leakage current, loss of ground (ISO/DIS 17987 Param 60)	GND = V <sub>SUP</sub> , 0 V ≤ V <sub>LIN</sub> = 36 V, V <sub>SUP</sub> = 24 V; See <a href="#">Figure 8-8</a>	- 2		2	mA
I <sub>leak_gnd(dom)</sub>	Leakage current, loss of ground <sup>(5)</sup>	V <sub>SUP</sub> = 8 V, GND = open, V <sub>SUP</sub> = 18 V, GND = open R <sub>Commander</sub> = 1 kΩ, C <sub>L</sub> = 1 nF R <sub>Responder</sub> = 20 kΩ, C <sub>L</sub> = 1 nF LIN = dominant	-1		1	mA
I <sub>leak_gnd(rec)</sub>	Leakage current, loss of ground <sup>(5)</sup>	V <sub>SUP</sub> = 8 V, GND = open, V <sub>SUP</sub> = 18 V, GND = open R <sub>Commander</sub> = 1 kΩ, C <sub>L</sub> = 1 nF R <sub>Responder</sub> = 20 kΩ, C <sub>L</sub> = 1 nF LIN = recessive	-100		100	μA
I <sub>BUS_NO_BAT</sub>	Leakage current, loss of supply (ISO/DIS 17987 Param 61)	0 V ≤ V <sub>LIN</sub> ≤ 48 V, V <sub>SUP</sub> = GND; See <a href="#">Figure 8-9</a>			5	μA
V <sub>BUSdom</sub>	Low-level input voltage (ISO/DIS 17987 Param , 62)	LIN dominant (including LIN dominant for wake up); See <a href="#">Figure 8-3</a> and <a href="#">Figure 8-4</a>			0.4	V <sub>SUP</sub>
V <sub>BUSrec</sub>	High-level input voltage (ISO/DIS 17987 Param , 63)	LIN recessive; See <a href="#">Figure 8-3</a> and <a href="#">Figure 8-4</a>	0.6			V <sub>SUP</sub>
V <sub>IH</sub>	LIN recessive high-level input voltage <sup>(1) (2)</sup>	7 V ≤ V <sub>SUP</sub> ≤ 18 V	0.47		0.6	V <sub>SUP</sub>
V <sub>IL</sub>	LIN dominant low-level input voltage <sup>(1) (2)</sup>	7 V ≤ V <sub>SUP</sub> ≤ 18 V	0.4		0.53	V <sub>SUP</sub>
V <sub>BUS_CNT</sub>	Receiver center threshold (ISO/DIS 17987 Param , 64)	V <sub>BUS_CNT</sub> = (V <sub>BUSdom</sub> + V <sub>BUSrec</sub> )/2; See <a href="#">Figure 8-3</a> and <a href="#">Figure 8-4</a>	0.475	0.5	0.525	V <sub>SUP</sub>
V <sub>HYS</sub>	Hysteresis voltage (ISO/DIS 17987 Param , 65)	V <sub>HYS</sub> = (V <sub>BUSrec</sub> - V <sub>BUSdom</sub> ); See <a href="#">Figure 8-3</a> and <a href="#">Figure 8-4</a>			0.175	V <sub>SUP</sub>
V <sub>HYS</sub>	Hysteresis voltage (SAE J2602)	V <sub>HYS</sub> = V <sub>IH</sub> - V <sub>IL</sub> ; See <a href="#">Figure 8-3</a> and <a href="#">Figure 8-4</a>	0.07		0.175	V <sub>SUP</sub>
V <sub>SERIAL_DIODE</sub>	Serial diode LIN termination pullup path (ISO/DIS 17987 Param , 66)	I <sub>SERIAL_DIODE</sub> = 10 μA	0.4	0.7	1	V
R <sub>PU</sub>	Pull-up resistor to V <sub>SUP</sub> (ISO/DIS 17987 Param , 71)	Normal and Standby modes	20	45	60	kΩ
I <sub>RSLEEP</sub>	Pull-up current source to V <sub>SUP</sub>	Sleep mode, V <sub>SUP</sub> = 27 V, LIN = GND	- 20		- 2	μA

## 7.6 Electrical Characteristics (continued)

parameters valid across  $-40^{\circ}\text{C} \leq T_A \leq 125^{\circ}\text{C}$  (unless otherwise noted)

PARAMETER		TEST CONDITIONS	MIN	TYP	MAX	UNIT
C <sub>LINPIN</sub>	Capacitance of the LIN pin	V <sub>SUP</sub> = 14 V			25	pF

- (1) SAE 2602 commander node load conditions: 5.5 nF/4 k $\Omega$  and 899 pF/20 k $\Omega$
- (2) SAE 2602 responder node load conditions: 5.5 nF/875  $\Omega$  and 899 pF/900  $\Omega$
- (3) ISO 17987 bus load conditions (C<sub>LINBUS</sub>, R<sub>LINBUS</sub>) include 1 nF/1 k $\Omega$ ; 6.8 nF/660  $\Omega$ ; 10 nF/500  $\Omega$ .
- (4) RXD uses open drain output structure therefore V<sub>OL</sub> level is based upon microcontroller supply voltage V<sub>CC</sub>.
- (5) I<sub>leak gnd</sub> = (V<sub>BAT</sub> - V<sub>LIN</sub>)/R<sub>Load</sub>

## 7.7 Duty Cycle Characteristics

parameters valid across  $-40^{\circ}\text{C} \leq T_A \leq 125^{\circ}\text{C}$  (unless otherwise noted)

PARAMETER		TEST CONDITIONS	MIN	TYP	MAX	UNIT
D1 <sub>12V</sub>	Duty Cycle 1 (ISO/DIS 17987 Param 27) <sup>(3)</sup>	TH <sub>REC(MAX)</sub> = 0.744 x V <sub>SUP</sub> , TH <sub>DOM(MAX)</sub> = 0.581 x V <sub>SUP</sub> , V <sub>SUP</sub> = 7 V to 18 V, t <sub>BIT</sub> = 50 $\mu$ s (20 kbps), D1 = t <sub>BUS_rec(min)</sub> /(2 x t <sub>BIT</sub> ) (See Figure 8-10, Figure 8-11)	0.396			
D1 <sub>12V</sub>	Duty Cycle 1 (ISO/DIS 17987 Param 27) <sup>(3)</sup> <sup>(4)</sup>	TH <sub>REC(MAX)</sub> = 0.625 x V <sub>SUP</sub> , TH <sub>DOM(MAX)</sub> = 0.581 x V <sub>SUP</sub> , V <sub>SUP</sub> = 4 V to 7 V, t <sub>BIT</sub> = 50 $\mu$ s (20 kbps), D1 = t <sub>BUS_rec(min)</sub> /(2 x t <sub>BIT</sub> ) (See Figure 8-10, Figure 8-11)	0.396			
D1	Duty cycle 1 <sup>(1)</sup> <sup>(2)</sup> <sup>(4)</sup>	TH <sub>REC(MAX)</sub> = 0.744 x V <sub>SUP</sub> , TH <sub>DOM(MAX)</sub> = 0.581 x V <sub>SUP</sub> , V <sub>SUP</sub> = 7 V to 18 V, t <sub>BIT</sub> = 52 $\mu$ s, D1 = t <sub>BUS_rec(min)</sub> /(2 x t <sub>BIT</sub> ) (See Figure 8-10, Figure 8-11)	0.396			
D2 <sub>12V</sub>	Duty Cycle 2 (ISO/DIS 17987 Param 28) <sup>(3)</sup>	TH <sub>REC(MIN)</sub> = 0.422 x V <sub>SUP</sub> , TH <sub>DOM(MIN)</sub> = 0.284 x V <sub>SUP</sub> , V <sub>SUP</sub> = 7 V to 18 V, t <sub>BIT</sub> = 50 $\mu$ s (20 kbps), D2 = t <sub>BUS_rec(MAX)</sub> /(2 x t <sub>BIT</sub> ) (See Figure 8-10, Figure 8-11)			0.581	
D2 <sub>12V</sub>	Duty Cycle 2 <sup>(3)</sup> <sup>(4)</sup>	TH <sub>REC(MIN)</sub> = 0.546 x V <sub>SUP</sub> , TH <sub>DOM(MIN)</sub> = 0.4 x V <sub>SUP</sub> , V <sub>SUP</sub> = 4 V to 7 V, t <sub>BIT</sub> = 50 $\mu$ s (20 kbps), D2 = t <sub>BUS_rec(MAX)</sub> /(2 x t <sub>BIT</sub> ) (See Figure 8-10, Figure 8-11)			0.581	
D2	Duty Cycle 2 <sup>(1)</sup> <sup>(2)</sup> <sup>(4)</sup>	TH <sub>REC(MIN)</sub> = 0.422 x V <sub>SUP</sub> , TH <sub>DOM(MIN)</sub> = 0.284 x V <sub>SUP</sub> , V <sub>SUP</sub> = 7 V to 18 V, t <sub>BIT</sub> = 52 $\mu$ s, D2 = t <sub>BUS_rec(MAX)</sub> /(2 x t <sub>BIT</sub> ) (See Figure 8-10, Figure 8-11)			0.581	
D3 <sub>12V</sub>	Duty Cycle 3 (ISO/DIS 17987 Param 29) <sup>(3)</sup>	TH <sub>REC(MAX)</sub> = 0.778 x V <sub>SUP</sub> , TH <sub>DOM(MAX)</sub> = 0.616 x V <sub>SUP</sub> , V <sub>SUP</sub> = 7 V to 18 V, t <sub>BIT</sub> = 96 $\mu$ s (10.4 kbps), D3 = t <sub>BUS_rec(min)</sub> /(2 x t <sub>BIT</sub> ) (See Figure 8-10, Figure 8-11)	0.417			
D3 <sub>12V</sub>	Duty Cycle 3 <sup>(3)</sup> <sup>(4)</sup>	TH <sub>REC(MAX)</sub> = 0.645 x V <sub>SUP</sub> , TH <sub>DOM(MAX)</sub> = 0.616 x V <sub>SUP</sub> , V <sub>SUP</sub> = 4 V to 7 V, t <sub>BIT</sub> = 96 $\mu$ s (10.4 kbps), D3 = t <sub>BUS_rec(min)</sub> /(2 x t <sub>BIT</sub> ) (See Figure 8-10, Figure 8-11)	0.417			
D3	Duty Cycle 3 <sup>(1)</sup> <sup>(2)</sup> <sup>(4)</sup>	TH <sub>REC(MAX)</sub> = 0.778 x V <sub>SUP</sub> , TH <sub>DOM(MAX)</sub> = 0.616 x V <sub>SUP</sub> , V <sub>SUP</sub> = 7 V to 18 V, t <sub>BIT</sub> = 96 $\mu$ s, D3 = t <sub>BUS_rec(min)</sub> /(2 x t <sub>BIT</sub> ) (See Figure 8-10, Figure 8-11)	0.417			
D4 <sub>12V</sub>	Duty Cycle 4 (ISO/DIS 17987 Param 30) <sup>(3)</sup>	TH <sub>REC(MIN)</sub> = 0.389 x V <sub>SUP</sub> , TH <sub>DOM(MIN)</sub> = 0.251 x V <sub>SUP</sub> , V <sub>SUP</sub> = 7 V to 18 V, t <sub>BIT</sub> = 96 $\mu$ s (10.4 kbps), D4 = t <sub>BUS_rec(MAX)</sub> /(2 x t <sub>BIT</sub> ) (See Figure 8-10, Figure 8-11)			0.59	

## 7.7 Duty Cycle Characteristics (continued)

parameters valid across  $-40^{\circ}\text{C} \leq T_A \leq 125^{\circ}\text{C}$  (unless otherwise noted)

PARAMETER		TEST CONDITIONS	MIN	TYP	MAX	UNIT
D4 <sub>12V</sub>	Duty Cycle 4 <sup>(3) (4)</sup>	$T_{H_{REC(MIN)}} = 0.422 \times V_{SUP}$ , $T_{H_{DOM(MIN)}} = 0.284 \times V_{SUP}$ , $V_{SUP} = 4\text{ V to }7\text{ V}$ , $t_{BIT} = 96\ \mu\text{s}$ (10.4 kbps), $D4 = t_{BUS\_rec(MAX)}/(2 \times t_{BIT})$ (See <a href="#">Figure 8-10</a> , <a href="#">Figure 8-11</a> )			0.59	
D4	Duty Cycle 4 <sup>(1) (2) (4)</sup>	$T_{H_{REC(MIN)}} = 0.389 \times V_{SUP}$ $T_{H_{DOM(MIN)}} = 0.251 \times V_{SUP}$ $V_{SUP} = 7\text{ V to }18\text{ V}$ , $t_{BIT} = 96\ \mu\text{s}$ $D4 = t_{BUS\_rec(MAX)}/(2 \times t_{BIT})$ (See <a href="#">Figure 8-10</a> , <a href="#">Figure 8-11</a> )			0.59	
D1 <sub>24V</sub>	Duty Cycle 1 (ISO/DIS 17987 Param 27) <sup>(1)</sup>	$T_{H_{REC(MAX)}} = 0.710 \times V_{SUP}$ , $T_{H_{DOM(MAX)}} = 0.544 \times V_{SUP}$ , $V_{SUP} = 15\text{ V to }36\text{ V}$ , $t_{BIT} = 50\ \mu\text{s}$ (20 kbps), $D1 = t_{BUS\_rec(min)}/(2 \times t_{BIT})$ (See <a href="#">Figure 8-10</a> , <a href="#">Figure 8-11</a> )	0.33			
D2 <sub>24V</sub>	Duty Cycle 2 (ISO/DIS 17987 Param 28)	$T_{H_{REC(MIN)}} = 0.446 \times V_{SUP}$ , $T_{H_{DOM(MIN)}} = 0.302 \times V_{SUP}$ , $V_{SUP} = 15.6\text{ V to }36\text{ V}$ , $t_{BIT} = 50\ \mu\text{s}$ (20 kbps), $D2 = t_{BUS\_rec(MAX)}/(2 \times t_{BIT})$ (See <a href="#">Figure 8-10</a> , <a href="#">Figure 8-11</a> )			0.642	
D3 <sub>24V</sub>	Duty Cycle 3 (ISO/DIS 17987 Param 29)	$T_{H_{REC(MAX)}} = 0.744 \times V_{SUP}$ , $T_{H_{DOM(MAX)}} = 0.581 \times V_{SUP}$ , $V_{SUP} = 7\text{ V to }36\text{ V}$ , $t_{BIT} = 96\ \mu\text{s}$ (10.4 kbps), $D3 = t_{BUS\_rec(min)}/(2 \times t_{BIT})$ (See <a href="#">Figure 8-10</a> , <a href="#">Figure 8-11</a> )	0.386			
D4 <sub>24V</sub>	Duty Cycle 4 (ISO/DIS 17987 Param 30) <sup>(4)</sup>	$T_{H_{REC(MIN)}} = 0.422 \times V_{SUP}$ , $T_{H_{DOM(MIN)}} = 0.284 \times V_{SUP}$ , $V_{SUP} = 7.6\text{ V to }36\text{ V}$ , $t_{BIT} = 96\ \mu\text{s}$ (10.4 kbps), $D4 = t_{BUS\_rec(MAX)}/(2 \times t_{BIT})$ (See <a href="#">Figure 8-10</a> , <a href="#">Figure 8-11</a> )			0.591	
D1 <sub>LB</sub>	Duty cycle 1 at low battery <sup>(1) (2) (4)</sup>	$T_{H_{REC(MAX)}} = 0.665 \times V_{SUP}$ , $T_{H_{DOM(MAX)}} = 0.499 \times V_{SUP}$ , $V_{SUP} = 5.5\text{ V to }7\text{ V}$ , $t_{BIT} = 52\ \mu\text{s}$	0.396			
D2 <sub>LB</sub>	Duty cycle 2 at low battery <sup>(1) (2) (4)</sup>	$T_{H_{REC(MAX)}} = 0.496 \times V_{SUP}$ $T_{H_{DOM(MAX)}} = 0.361 \times V_{SUP}$ $V_{SUP} = 6.1\text{ V to }7\text{ V}$ , $t_{BIT} = 52\ \mu\text{s}$			0.581	
D3 <sub>LB</sub>	Duty cycle 3 at low battery <sup>(1) (2) (4)</sup>	$T_{H_{REC(MAX)}} = 0.665 \times V_{SUP}$ , $T_{H_{DOM(MAX)}} = 0.499 \times V_{SUP}$ , $V_{SUP} = 5.5\text{ V to }7\text{ V}$ , $t_{BIT} = 96\ \mu\text{s}$	0.396			
D4 <sub>LB</sub>	Duty cycle 4 at low battery <sup>(1) (2) (4)</sup>	$T_{H_{REC(MAX)}} = 0.496 \times V_{SUP}$ $T_{H_{DOM(MAX)}} = 0.361 \times V_{SUP}$ $V_{SUP} = 6.1\text{ V to }7\text{ V}$ , $t_{BIT} = 96\ \mu\text{s}$			0.581	
Tr-d max	Transmitter propagation delay timings for the duty cycle <sup>(1) (2) (4)</sup> Recessive to dominant	$T_{H_{REC(MAX)}} = 0.744 \times V_{SUP}$ , $T_{H_{DOM(MAX)}} = 0.581 \times V_{SUP}$ $7\text{ V} \leq V_{SUP} \leq 18\text{ V}$ , $t_{BIT} = 52\ \mu\text{s}$ $t_{REC(MAX)_D1} - t_{DOM(MIN)_D1}$			10.8	$\mu\text{s}$
Td-r max	Transmitter propagation delay timings for the duty cycle <sup>(1) (2) (4)</sup> Dominant to recessive	$T_{H_{REC(MAX)}} = 0.422 \times V_{SUP}$ , $T_{H_{DOM(MAX)}} = 0.284 \times V_{SUP}$ $7\text{ V} \leq V_{SUP} \leq 18\text{ V}$ , $t_{BIT} = 52\ \mu\text{s}$ $t_{DOM(MAX)_D2} - t_{REC(MIN)_D2}$			8.4	$\mu\text{s}$
Tr-d max	Transmitter propagation delay timings for the duty cycle <sup>(1) (2) (4)</sup> Recessive to dominant	$T_{H_{REC(MAX)}} = 0.778 \times V_{SUP}$ $T_{H_{DOM(MAX)}} = 0.616 \times V_{SUP}$ $7\text{ V} \leq V_{SUP} \leq 18\text{ V}$ , $t_{BIT} = 96\ \mu\text{s}$ $t_{REC(MAX)_D3} - t_{DOM(MIN)_D3}$			15.9	$\mu\text{s}$
Td-r max	Transmitter propagation delay timings for the duty cycle <sup>(1) (2) (4)</sup> Dominant to recessive	$T_{H_{REC(MIN)}} = 0.389 \times V_{SUP}$ $T_{H_{DOM(MIN)}} = 0.251 \times V_{SUP}$ $7\text{ V} \leq V_{SUP} \leq 18\text{ V}$ , $t_{BIT} = 96\ \mu\text{s}$ $t_{DOM(MAX)_D4} - t_{REC(MIN)_D4}$			17.28	$\mu\text{s}$

## 7.7 Duty Cycle Characteristics (continued)

parameters valid across  $-40^{\circ}\text{C} \leq T_A \leq 125^{\circ}\text{C}$  (unless otherwise noted)

PARAMETER		TEST CONDITIONS	MIN	TYP	MAX	UNIT
Tr-d max_low	Low battery transmitter propagation delay timings for the duty cycle <sup>(1) (2) (4)</sup> Recessive to dominant	$T_{H_{REC(MAX)}} = 0.665 \times V_{SUP}$ , $T_{H_{DOM(MAX)}} = 0.499 \times V_{SUP}$ $5.5 \text{ V} \leq V_{SUP} \leq 7 \text{ V}$ , $t_{BIT} = 52 \mu\text{s}$ $t_{REC(MAX)_{low}} - t_{DOM(MIN)_{low}}$			10.8	$\mu\text{s}$
Td-r max_low	Low battery transmitter propagation delay timings for the duty cycle <sup>(1) (2) (4)</sup> Dominant to recessive	$T_{H_{REC(MAX)}} = 0.496 \times V_{SUP}$ $T_{H_{DOM(MAX)}} = 0.361 \times V_{SUP}$ $6.1 \text{ V} \leq V_{SUP} \leq 7 \text{ V}$ , $t_{BIT} = 52 \mu\text{s}$ $t_{DOM(MAX)_{low}} - t_{REC(MIN)_{low}}$			8.4	$\mu\text{s}$

- (1) SAE 2602 commander node load conditions: 5.5 nF/4 k $\Omega$  and 899 pF/20 k $\Omega$   
 (2) SAE 2602 responder node load conditions: 5.5 nF/875  $\Omega$  and 899 pF/900  $\Omega$   
 (3) ISO 17987 bus load conditions ( $C_{LINBUS}$ ,  $R_{LINBUS}$ ) include 1 nF/1 k $\Omega$ ; 6.8 nF/660  $\Omega$ ; 10 nF/500  $\Omega$ .  
 (4) Specified by design

## 7.8 Switching Characteristics

parameters valid across  $-40^{\circ}\text{C} \leq T_A \leq 125^{\circ}\text{C}$  (unless otherwise noted)

SYMBOL	DESCRIPTION	TEST CONDITIONS	MIN	NOM	MAX	UNIT
$t_{rx\_pdr}$	Receiver rising propagation delay time (ISO/DIS 17987 Param 31)	$R_{RXD} = 2.4 \text{ k}\Omega$ , $C_{RXD} = 20 \text{ pF}$ (See <a href="#">Figure 8-12</a> and <a href="#">Figure 8-13</a> )			6	$\mu\text{s}$
$t_{rx\_pdf}$	Receiver falling propagation delay time (ISO/DIS 17987 Param 31)				6	$\mu\text{s}$
$t_{rs\_sym}$	Symmetry of receiver propagation delay time	Rising edge with respect to falling edge, ( $trx\_sym = trx\_pdf - trx\_pdr$ ), $R_{RXD} = 2.4 \text{ k}\Omega$ , $C_{RXD} = 20 \text{ pF}$ (See <a href="#">Figure 8-12</a> and <a href="#">Figure 8-13</a> )	-2		2	$\mu\text{s}$
$t_{LINBUS}$	LIN wakeup time (Minimum dominant time on LIN bus for wakeup)	See <a href="#">Figure 8-16</a> , <a href="#">Figure 9-2</a> and <a href="#">Figure 9-3</a>	25	100	150	$\mu\text{s}$
$t_{CLEAR}$	Time to clear false wakeup prevention logic if LIN bus had a bus stuck dominant fault (recessive time on LIN bus to clear bus stuck dominant fault)	See <a href="#">Figure 9-3</a>	8	17	50	$\mu\text{s}$
$t_{DST}$	Dominant state time out		20	34	80	ms
$t_{MODE\_CHANGE}$	Mode change delay time	Time to change from standby mode to normal mode or normal mode to sleep mode through EN pin; See <a href="#">Figure 8-14</a> and <a href="#">Figure 9-4</a>	2		15	$\mu\text{s}$
$t_{NOMINT}$	Normal mode initialization time	Time for normal mode to initialize and data on RXD pin to be valid; See <a href="#">Figure 8-14</a>			35	$\mu\text{s}$
$t_{PWR}$	Power up time	Upon power up time it takes for valid data on RXD			1.5	ms

## 7.9 Typical Characteristics



图 7-1.  $V_{OH}$  vs  $V_{SUP}$  and Temperature



图 7-2.  $V_{OL}$  vs  $V_{SUP}$  and Temperature

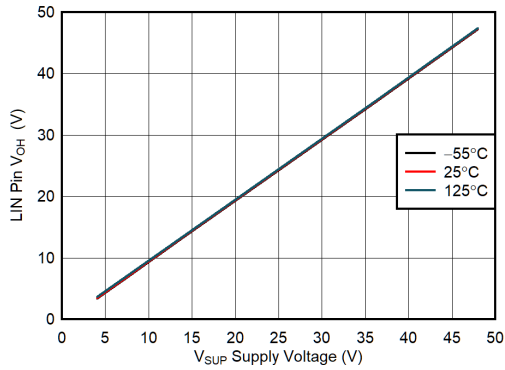

Normal Mode (Dominant)

图 7-3. Supply Current vs Voltage Supply Across Temperature

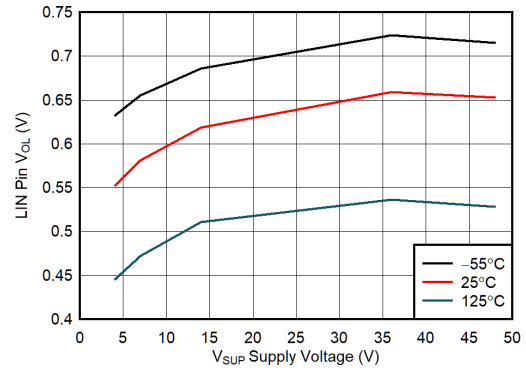
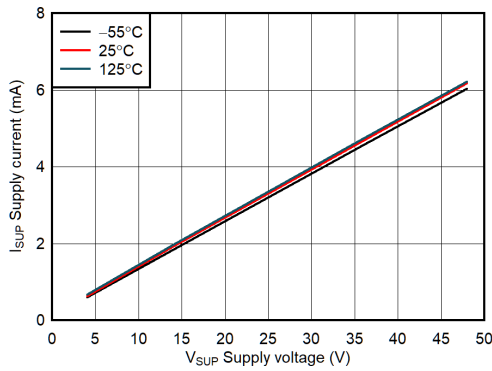
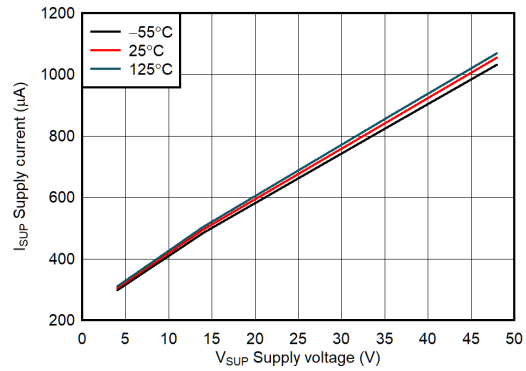

Normal Mode (Recessive)

图 7-4. Supply Current vs Voltage Supply Across Temperature

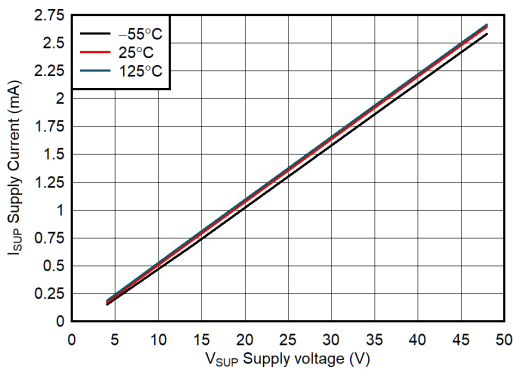

Standby Mode (Dominant)

图 7-5. Supply Current vs Voltage Supply and Temperature

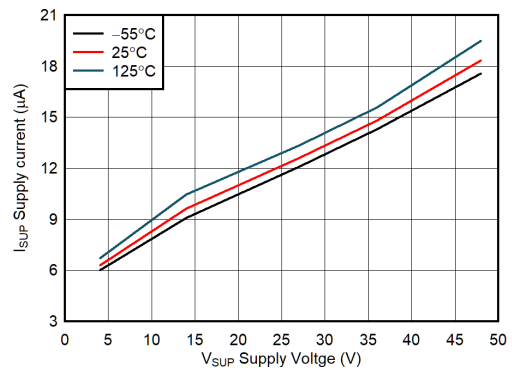

Standby Mode (Recessive)

图 7-6. Supply Current vs Voltage Supply and Temperature

## 7.9 Typical Characteristics (continued)

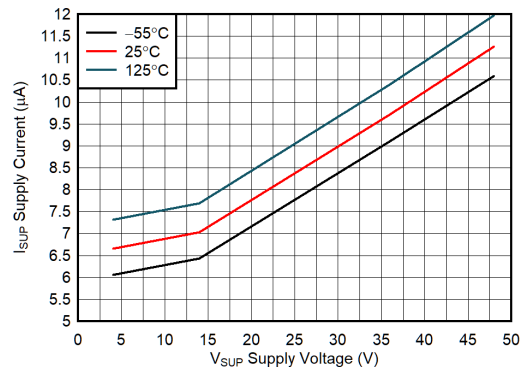

Sleep Mode

图 7-7. Supply Current vs Voltage Supply and Temperature

## 8 Parameter Measurement Information



图 8-1. Test System: Operating Voltage Range with RX and TX Access: Parameters 9, 10



图 8-2. RX Response: Operating Voltage Range

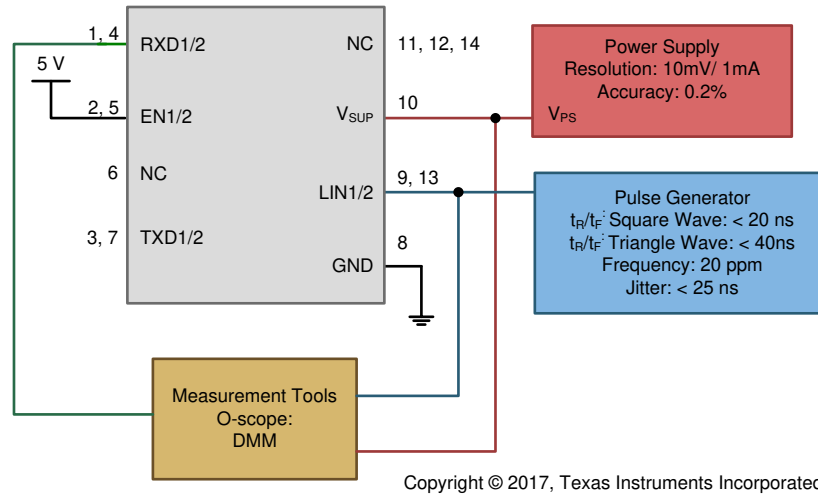

图 8-3. LIN Bus Input Signal

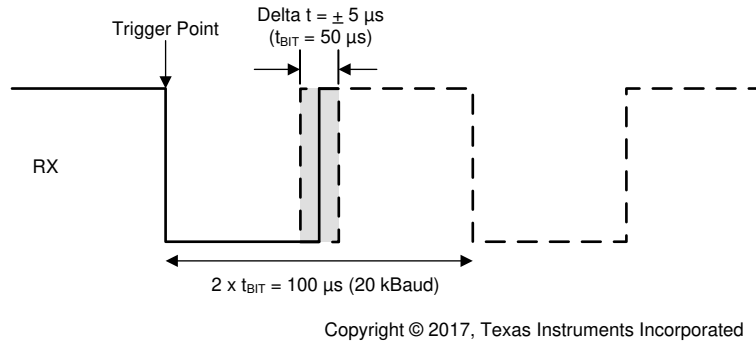

Copyright © 2017, Texas Instruments Incorporated

**图 8-4. LIN Receiver Test with RX access Parameters 17, 18, 19, 20**

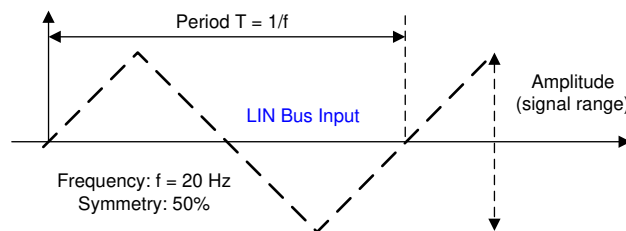
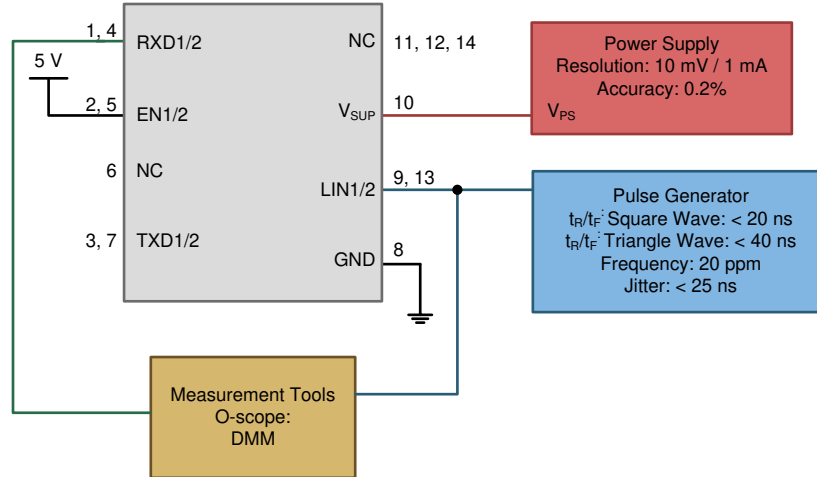
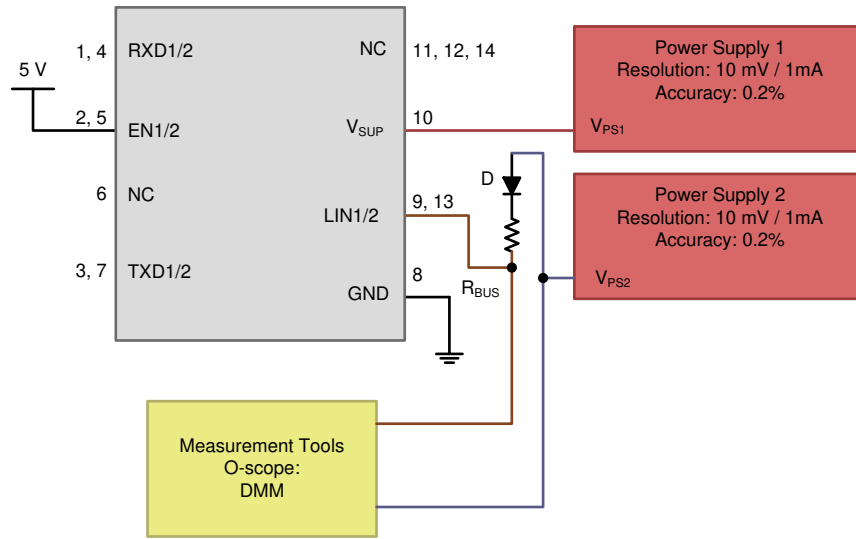

Copyright © 2017, Texas Instruments Incorporated

**图 8-5.  $V_{SUP\_NON\_OP}$  Parameters 11**



图 8-6. Test Circuit for  $I_{BUS\_PAS\_dom}$ ; TXD = Recessive State  $V_{BUS} = 0$  V, Parameters 13



图 8-7. Test Circuit for  $I_{BUS\_PAS\_rec}$  Param 14

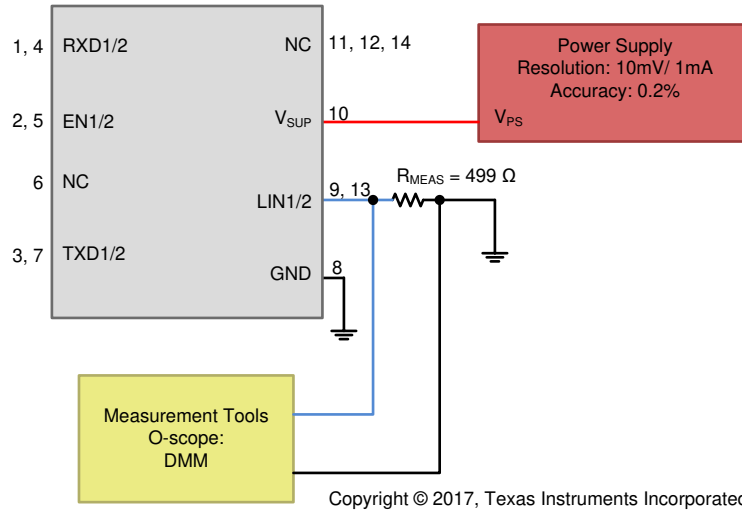

Copyright © 2017, Texas Instruments Incorporated

**图 8-8. Test Circuit for  $I_{BUS\_NO\_GND}$  Loss of GND**

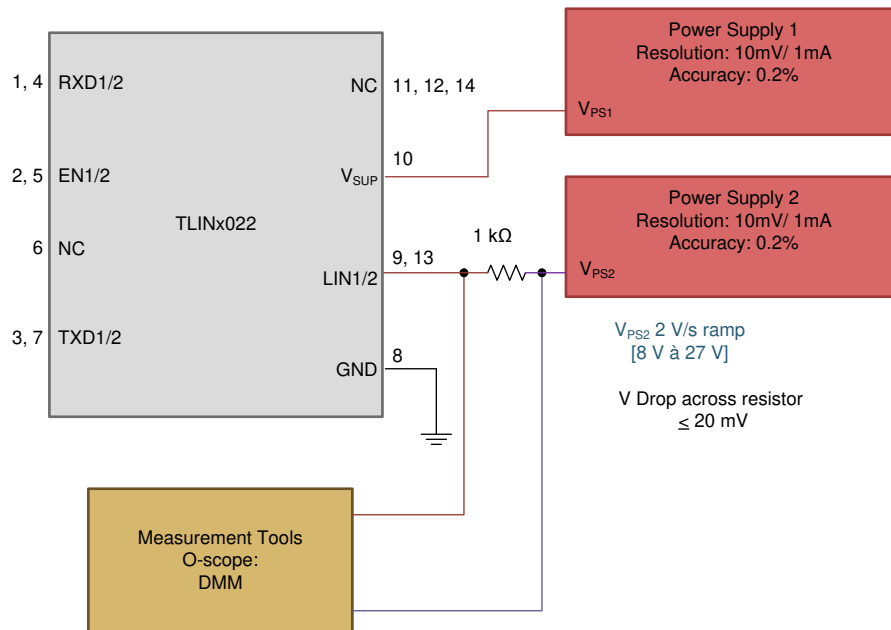
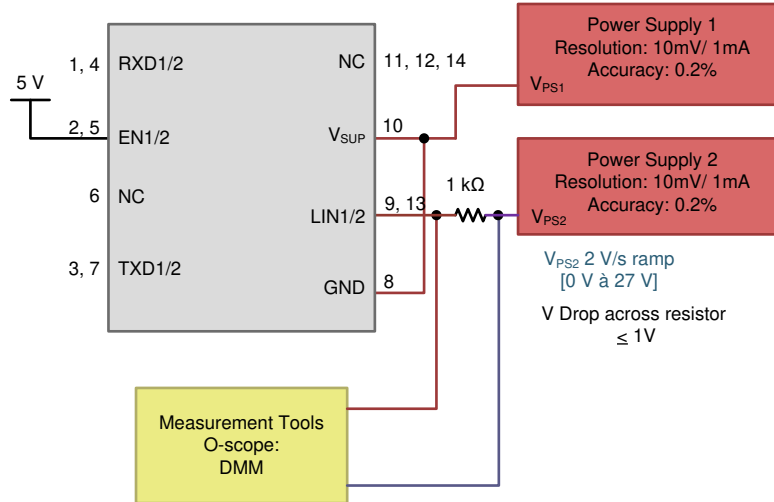
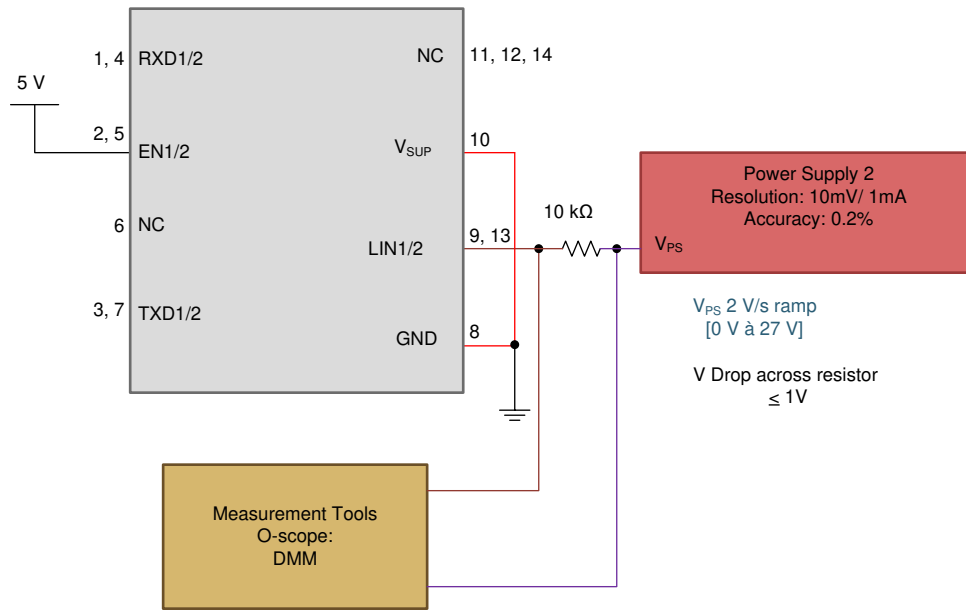

Copyright © 2017, Texas Instruments Incorporated

**图 8-9. Test Circuit for  $I_{BUS\_NO\_BAT}$  Loss of Battery**

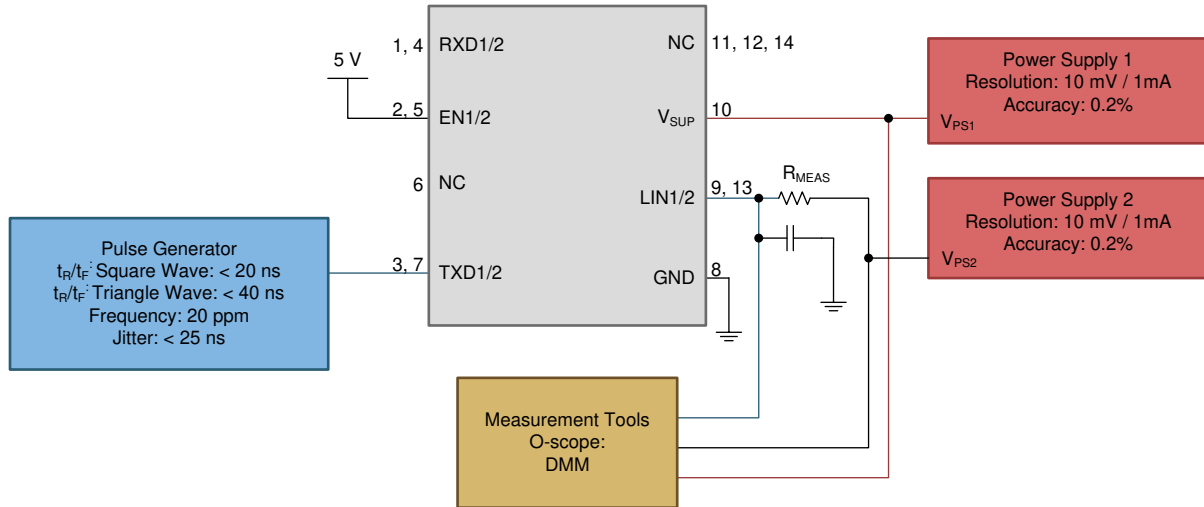

Copyright © 2017, Texas Instruments Incorporated

图 8-10. Test Circuit Slope Control and Duty Cycle Parameters 27, 28, 29, 30



图 8-11. Definition of Bus Timing Parameters



Copyright © 2017, Texas Instruments Incorporated

图 8-12. Propagation Delay Test Circuit; Parameters 31, 32

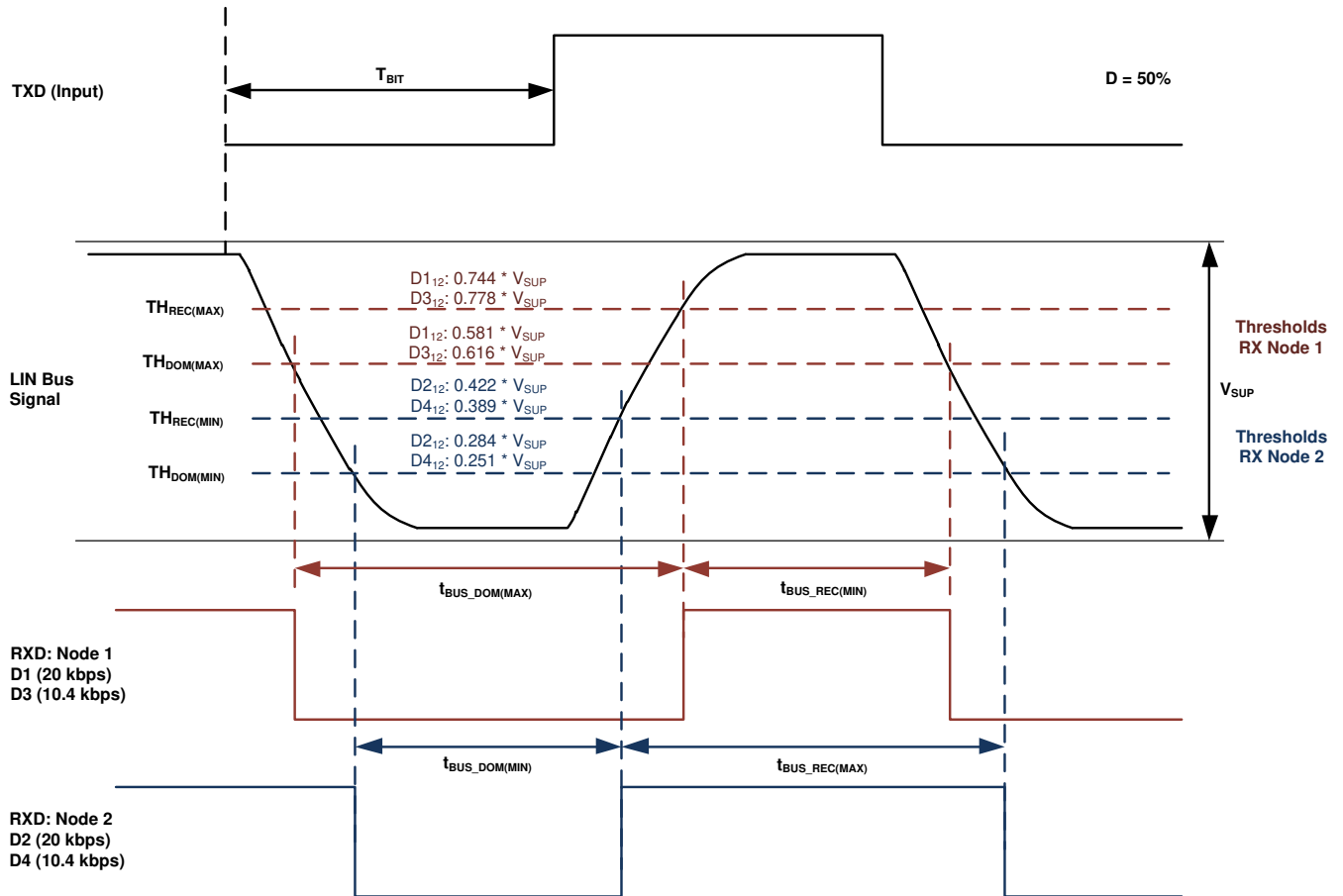
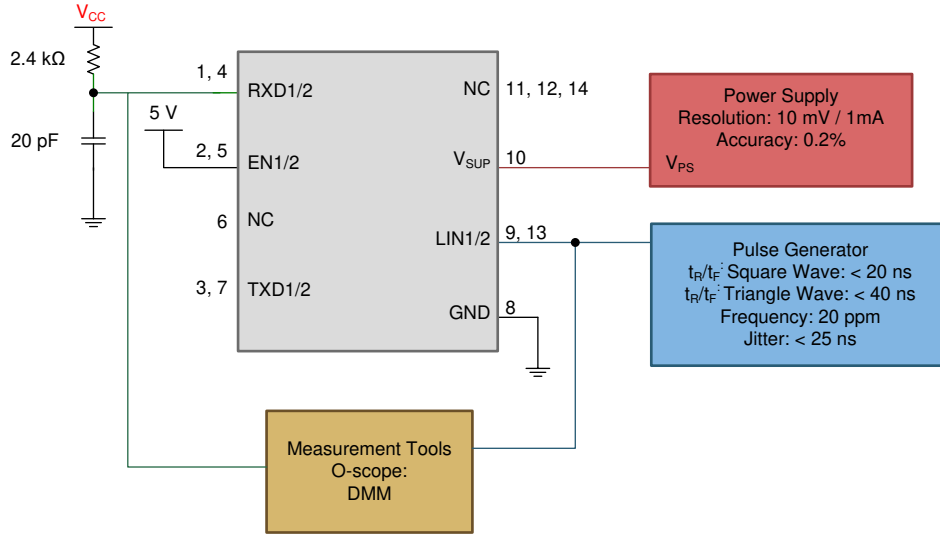

图 8-13. Propagation Delay



Copyright © 2017, Texas Instruments Incorporated

图 8-14. Mode Transitions

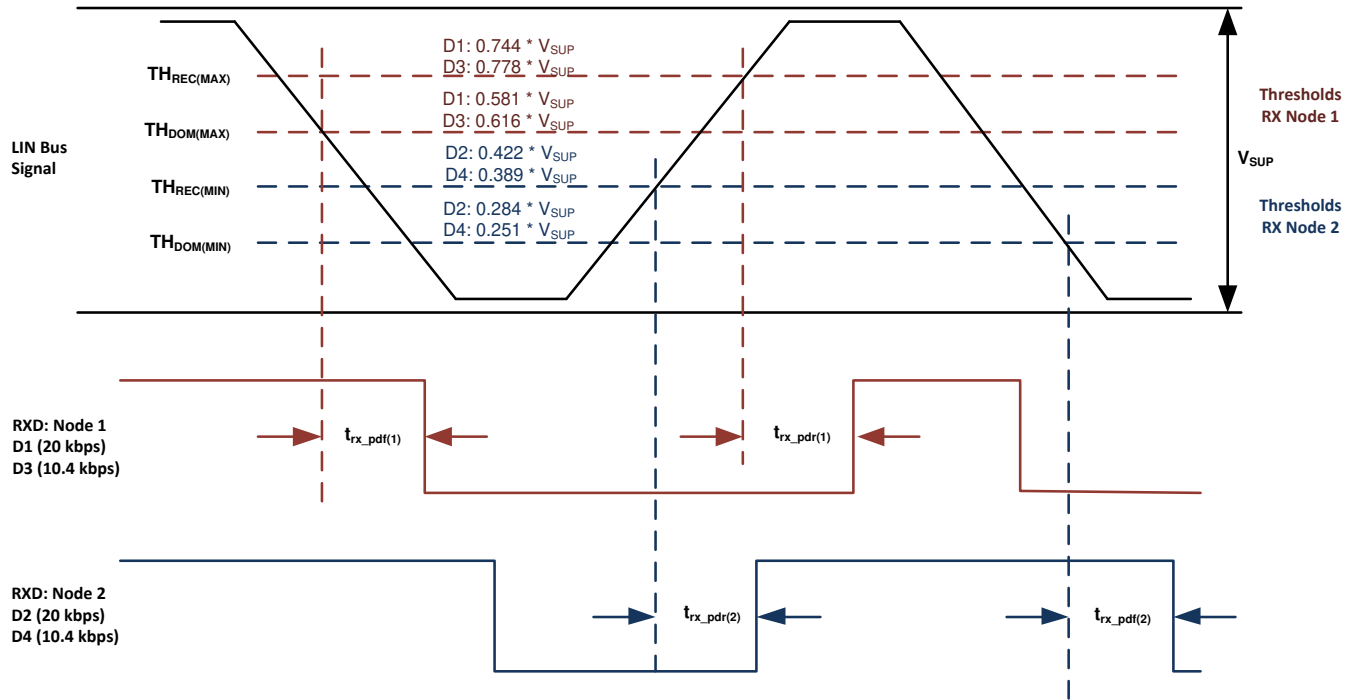
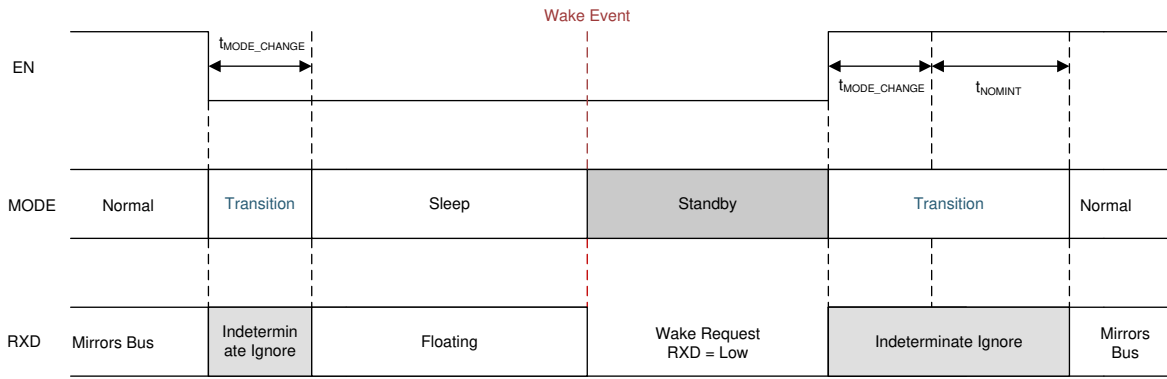

图 8-15. Wakeup Through EN



**图 8-16. Wakeup through LIN**

## 9 Detailed Description

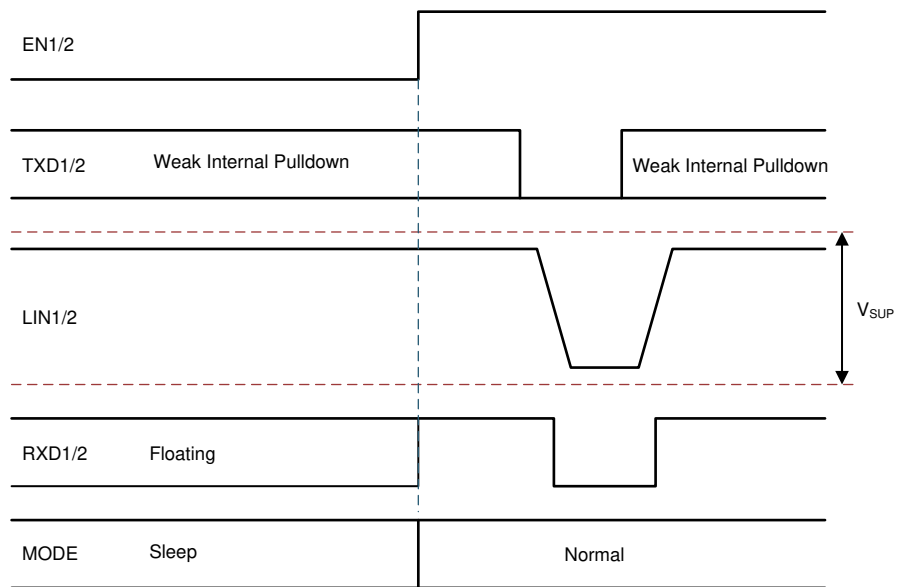
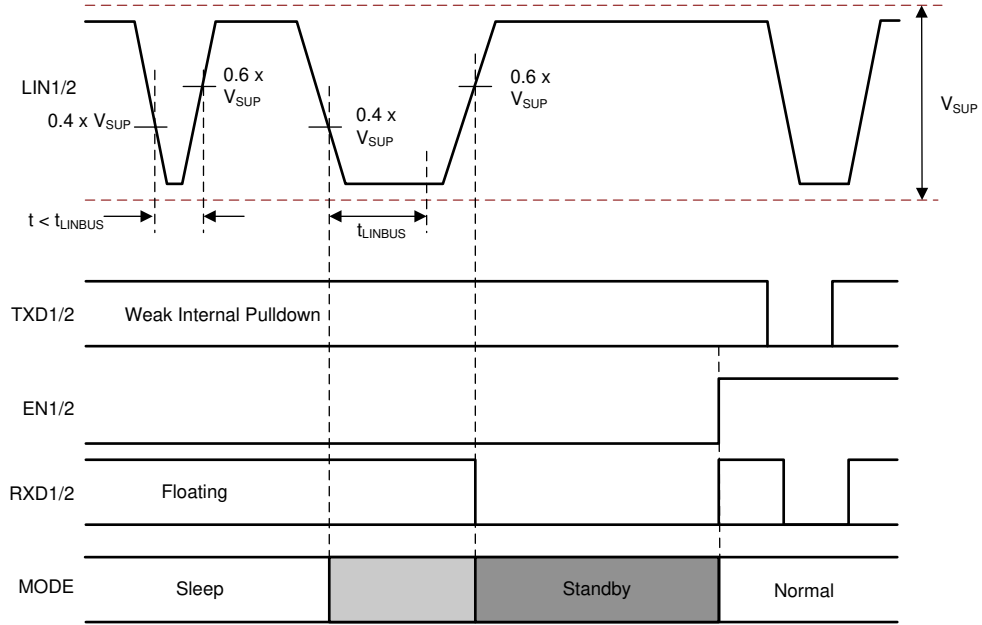
### 9.1 Overview

The TLIN2022A-Q1 device is a Dual Local Interconnect Network (LIN) physical layer transceiver, compliant to LIN 2.0, LIN 2.1, LIN 2.2, LIN 2.2A and ISO/DIS 17987 - 4 standards, with integrated wake-up and protection features. The LIN bus is a single wire bidirectional bus typically used for low speed in-vehicle networks. The device transmitter supports data rates from 2.4 kbps to 20 kbps. The device receiver works up to 100 kbps supporting in-line programming. The LIN protocol data stream on the TXD input is converted by the TLIN2022A-Q1 into a LIN bus signal using a current-limited wave-shaping driver as outlined by the LIN physical layer specification. The receiver converts the data stream to logic-level signals that are sent to the microprocessor through the open-drain RXD pin. The LIN bus has two states: dominant state (voltage near ground) and recessive state (voltage near battery). In the recessive state, the LIN bus is pulled high by the internal pull-up resistor (45 k $\Omega$ ) and a series diode. No external pull-up components are required for responder node applications. Commander node applications require an external pull-up resistor (1 k $\Omega$ ) plus a series diode per the LIN specification.

The device is designed to support 12-V and 24-V applications with a wide input voltage operating range and also supports low-power sleep mode. The device also provides two methods to wake up: EN pin and from the LIN bus.

The TLIN2022A-Q1 integrates ESD protection and fault protection which allow for a reduction in the required external components in end applications. In the event of a ground shift or supply voltage disconnection, the device prevents back-feed current through LIN to the supply input. The device also includes undervoltage detection, temperature shutdown protection, and loss-of-ground protection.

## 9.2 Functional Block Diagram

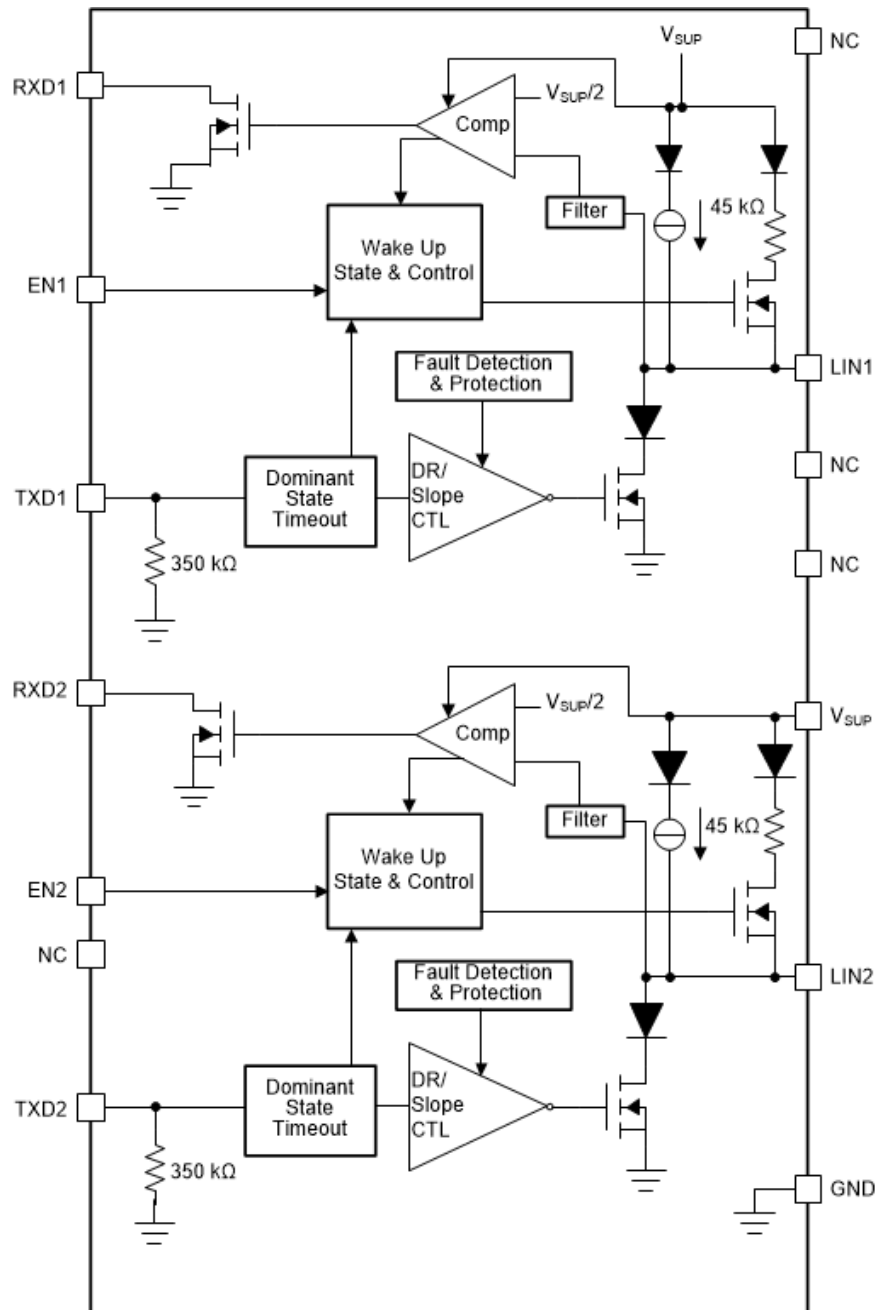

## 9.3 Feature Description

### 9.3.1 LIN (Local Interconnect Network) Bus

This high voltage input/output pin is a single wire LIN bus transmitter and receiver. The LIN pin can survive transient voltages up to 45 V. Reverse currents from the LIN to supply ( $V_{SUP}$ ) are minimized with blocking diodes, even in the event of a ground shift or loss of supply ( $V_{SUP}$ ).

#### 9.3.1.1 LIN Transmitter Characteristics

The transmitter has thresholds and AC parameters according to the LIN specification. The transmitter is a low-side transistor with internal current limitation and thermal shutdown. During a thermal shut-down condition, the transmitter is disabled to protect the device. There is an internal pull-up resistor with a serial diode structure to

$V_{SUP}$ , so no external pull-up components are required for the LIN responder node applications. An external pull-up resistor and series diode to  $V_{SUP}$  must be added when the device is used for a commander node application.

### 9.3.1.2 LIN Receiver Characteristics

The receiver characteristic thresholds are proportional to the device supply pin according to the LIN specification.

The receiver is capable of receiving higher data rates (> 100 kbps) than supported by LIN or SAEJ2602 specifications. This allows the TLIN2022A-Q1 to be used for high speed downloads at the end-of-line production or other applications. The actual data rate achievable depends on system time constants (bus capacitance and pull-up resistance) and driver characteristics used in the system.

#### 9.3.1.2.1 Termination

There is an internal pull-up resistor with a serial diode structure to  $V_{SUP}$ , so no external pull-up components are required for the LIN responder node applications. An external pull-up resistor (1 k $\Omega$ ) and a series diode to  $V_{SUP}$  must be added when the device is used for commander node applications as per the LIN specification.

Figure 9-1 shows a commander node configuration and how the voltage levels are defined

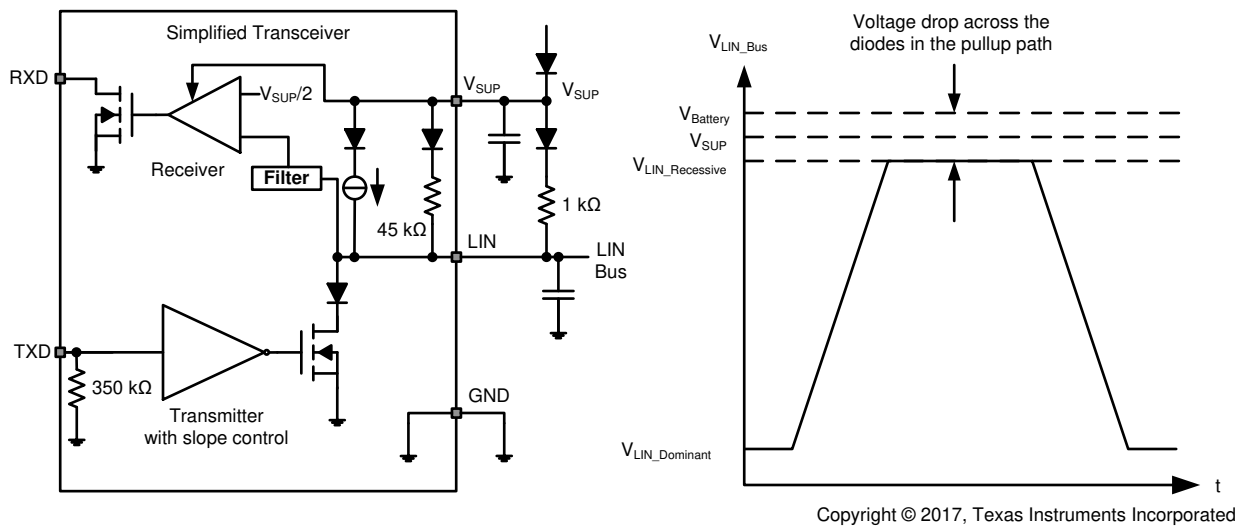

Figure 9-1. Commander Node Configuration with Voltage Levels

### 9.3.2 TXD

TXD is the interface to the MCU's LIN protocol controller or SCI / UART that is used to control the state of the LIN output. When TXD is low the LIN output is dominant (near ground). When TXD is high the LIN output is recessive (near  $V_{Battery}$ ). See Figure 9-1. The TXD input structure is compatible with processors using 3.3 V and 5 V I/O. TXD has an internal pull-down resistor. The LIN bus is protected from being stuck dominant through a system failure driving TXD low through the dominant state timeout timer.

### 9.3.3 RXD (Receive Output)

RXD is the interface to the MCU's LIN protocol controller or SCI / UART, which reports the state of the LIN bus voltage. LIN recessive (near  $V_{Battery}$ ) is represented by a high level on the RXD and LIN dominant (near ground) is represented by a low level on the RXD pin. The RXD output structure is an open-drain output stage. This allows the device to be used with 3.3 V and 5 V I/O processors. If the microcontroller's RXD pin does not have an integrated pull-up, an external pull-up resistor to the processor's I/O supply voltage is required. In standby mode the RXD pin is driven low to indicate a wake up request from the LIN bus.

### 9.3.4 $V_{SUP}$ (Supply Voltage)

$V_{SUP}$  is the power supply pin.  $V_{SUP}$  is connected to the battery through an external reverse battery blocking diode (see Figure 9-1). If there is a loss of power at the ECU level, the device has low leakage from the LIN pin,

which does not load the bus down. This is optimal for LIN systems in which some of the nodes are unpowered (ignition supplied) while the rest of the network remains powered (battery supplied).

### 9.3.5 GND (Ground)

GND is the device ground connection. The device can operate with a ground shift as long as the ground shift does not reduce the  $V_{SUP}$  below the minimum operating voltage, as well as ensuring the input and output voltages are within their appropriate thresholds. If there is a loss of ground at the ECU level, the device has extremely low leakage from the LIN pin, which does not load the bus down. This is optimal for LIN systems in which some of the nodes are unpowered (ignition supplied) while the rest of the network remains powered (battery supplied).

### 9.3.6 EN (Enable Input)

EN1 and EN2 control the operational modes of the respective LIN channel. When EN1/EN2 is high the LIN1/LIN2 channel is in normal operating mode allowing a transmission path from TXD to respective LIN bus and from LIN to RXD. When EN1/EN2 is low the LIN1/LIN2 channel is put into sleep mode and there is no transmission path available. The channel can enter normal mode only after wake up. EN has an internal pull-down resistor to ensure the channel remains in low power mode even if EN floats.

### 9.3.7 Protection Features

The TLIN2022A-Q1 has several protection features.

### 9.3.8 TXD Dominant Time Out (DTO)

During normal mode, if TXD is inadvertently driven permanently low by a hardware or software application failure, the LIN bus is protected by the dominant state timeout timer. This timer is triggered by a falling edge on the TXD pin. If the low signal remains on TXD for longer than  $t_{DST}$ , the transmitter is disabled, thus allowing the LIN bus to return to recessive state and communication to resume on the bus. The protection is cleared and the  $t_{DST}$  timer is reset by a rising edge on TXD. The TXD pin has an internal pull-down to ensure the LIN channel fails to a known state if TXD is disconnected. During this fault, the LIN channel remains in normal mode (assuming no change of state request on EN), the transmitter is disabled, the RXD pin reflects the LIN bus and the LIN bus pull-up termination remains on.

### 9.3.9 Bus Stuck Dominant System Fault: False Wake-Up Lockout

The TLIN2022A-Q1 contains logic to detect bus stuck dominant system faults and prevents the device from waking up falsely during the system fault. Upon entering sleep mode, the device detects the state of the LIN bus. If the bus is dominant, the wake-up logic is locked out until a valid recessive on the bus “clears” the bus stuck dominant, preventing excessive current use. [图 9-2](#) and [图 9-3](#) show the behavior of this protection.

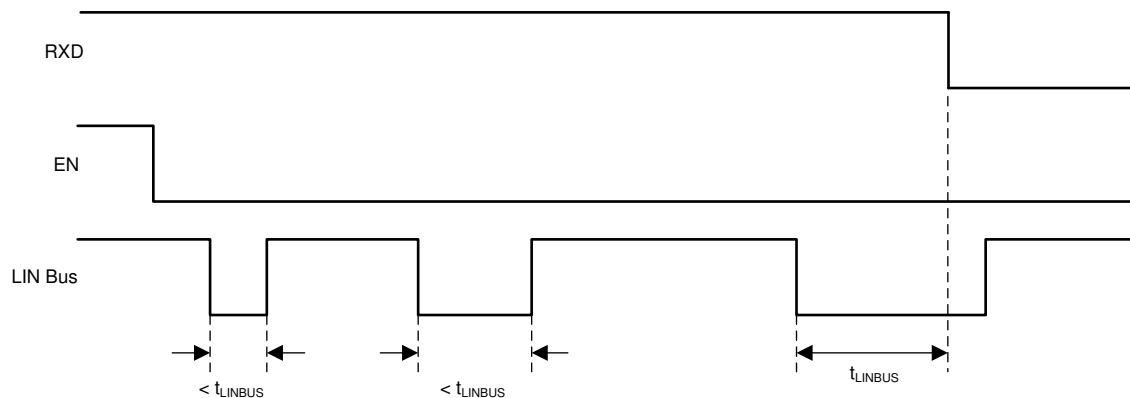

**图 9-2. No Bus Fault: Entering Sleep Mode with Bus Recessive Condition and Wake-up**



图 9-3. Bus Fault: Entering Sleep Mode with Bus Stuck Dominant Fault, Clearing, and Wake-up

### 9.3.10 Thermal Shutdown

The LIN transmitter is protected by limiting the current; however if the junction temperature of the device exceeds the thermal shutdown threshold, the device puts the LIN transmitter into the recessive state. Once the over-temperature fault condition has been removed and the junction temperature has cooled beyond the hysteresis temperature, the transmitter is re-enabled, assuming the device remained in the normal operation mode. During this fault, the transceiver remains in normal mode (assuming no change of state request on EN), the transmitter is in recessive state, the RXD pin reflects the LIN bus and LIN bus pull-up termination remains on.

### 9.3.11 Undervoltage on $V_{SUP}$

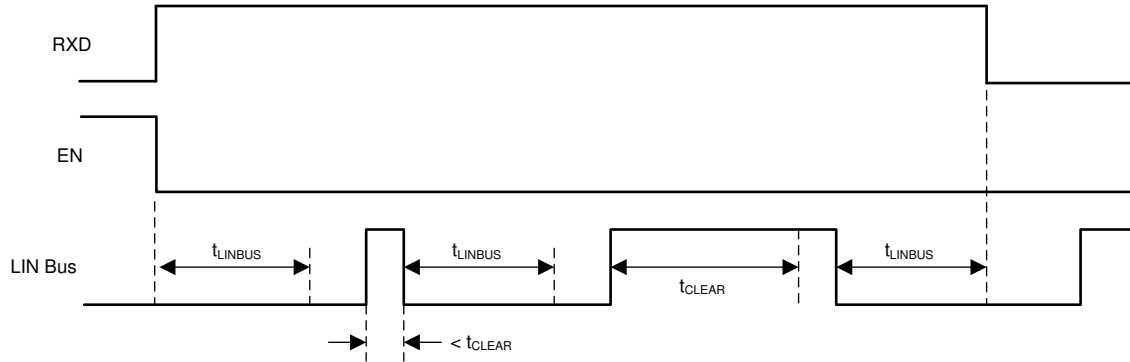
The TLIN2022A-Q1 contains a power on reset circuit to avoid false bus messages during undervoltage conditions when  $V_{SUP}$  is less than  $UV_{SUP}$ .

### 9.3.12 Unpowered Device and LIN Bus

In automotive applications some LIN nodes in a system can be unpowered (ignition supplied) while others in the network remains powered by the battery. The TLIN2022A-Q1 has a low unpowered leakage current from the bus so an unpowered node does not affect the network or load it down.

## 9.4 Device Functional Modes

The TLIN2022A-Q1 has three functional modes of operation; normal, sleep, and standby. The next sections describe these modes as well as how the device moves between the different modes. 图 9-4 graphically shows the relationship while 表 9-1 shows the state of pins.

表 9-1. Operating Modes

MODE	EN	RXD	LIN BUS TERMINATION	TRANSMITTER	COMMENT
Sleep	Low	Floating	Weak Current Pullup	Off	
Standby	Low	Low	45 k $\Omega$ (typical)	Off	Wake up event detected, waiting on MCU to set EN
Normal	High	LIN Bus Data	45 k $\Omega$ (typical)	Off	LIN transmission up to 20 kbps

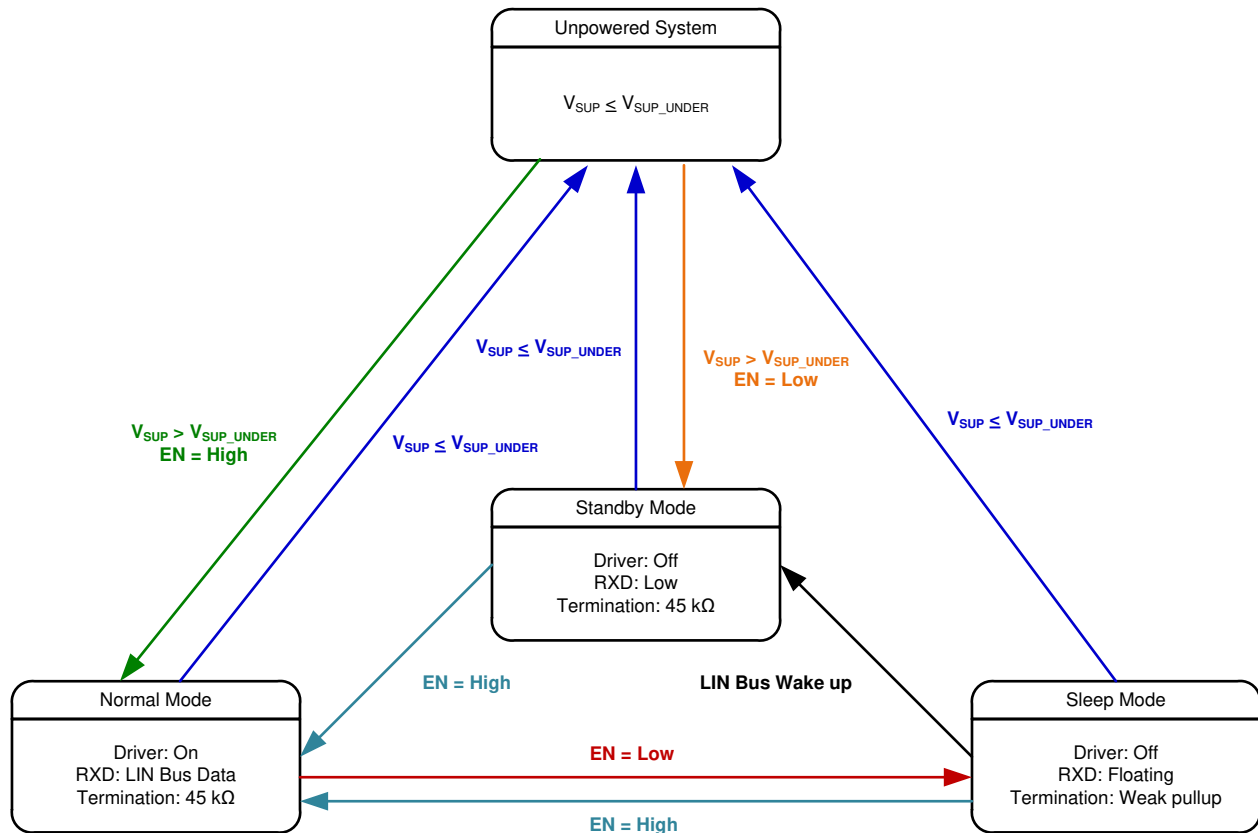

Copyright © 2017, Texas Instruments Incorporated

图 9-4. Operating State Diagram

### 9.4.1 Normal Mode

If the EN1 or EN2 pin is high at power up, the channel powers up in normal mode. If EN1 or EN2 is low, the channel powers up in standby mode. The EN pin controls the mode of the channel. In normal operational mode, the receiver and transmitter are active and the LIN transmission up to the LIN specified maximum of 20 kbps is supported. The receiver detects the data stream on the LIN bus and outputs it on RXD for the LIN controller. A recessive signal on the LIN bus is a logic high and a dominant signal on the LIN bus is a logic low. The driver transmits input data from TXD to the LIN bus. Normal mode is entered as EN transitions high while the LIN channel is in sleep or standby mode for  $> t_{MODE\_CHANGE}$  plus  $t_{NOMINT}$ .

### 9.4.2 Sleep Mode

Sleep Mode is the power saving mode for the TLIN2022A-Q1. Even with extremely low current consumption in this mode, the LIN channel can still wake-up from LIN bus through a wake-up signal or if EN is set high for  $\geq t_{MODE\_CHANGE}$ . The LIN bus is filtered to prevent false wake-up events. The wake-up events must be active for the respective time periods ( $t_{LINBUS}$ ).

Sleep mode is entered by setting EN low for longer than  $t_{MODE\_CHANGE}$ .

While the channel is in sleep mode, the following conditions exist.

- The LIN bus driver is disabled and the internal LIN bus termination is switched off (to minimize power loss if LIN is short circuited to ground). However, the weak current pull-up is active to prevent false wake-up events in case an external connection to the LIN bus is lost.
- The normal receiver is disabled.
- EN input and LIN wake-up receiver are active.

### 9.4.3 Standby Mode

This mode is entered whenever a wake-up event occurs through the LIN bus while the channel is in sleep mode. The LIN bus responder termination circuit is turned on when standby mode is entered. Standby mode is signaled through a low level on RXD. See [Standby Mode Application Note](#) for more application information.

When EN is set high for longer than  $t_{\text{MODE\_CHANGE}}$  while the channel is in standby mode, the device returns to normal mode and the normal transmission paths from TXD to LIN bus and LIN bus to RXD are enabled.

### 9.4.4 Wake-Up Events

There are two ways to wake-up from sleep mode:

- Remote wake-up initiated by the falling edge of a recessive (high) to dominant (low) state transition on LIN bus where the dominant state is held for  $t_{\text{LINBUS}}$  filter time. After this  $t_{\text{LINBUS}}$  filter time has been met and a rising edge on the LIN bus going from dominant state to recessive state initiates a remote wake-up event, eliminating false wake-ups from disturbances on the LIN bus or if the bus is shorted to ground.
- Local wake-up through EN being set high for longer than  $t_{\text{MODE\_CHANGE}}$ .

#### 9.4.4.1 Wake-Up Request (RXD)

When the TLIN2022A-Q1 encounters a wake-up event from the LIN bus, RXD goes low and the channel transitions to standby mode until EN is reasserted high and the channel enters normal mode. Once the LIN channel enters normal mode, the RXD pin releases the wake-up request signal and the RXD pin then reflects the receiver output from the corresponding LIN bus.

#### 9.4.4.2 Mode Transitions

When any of the LIN channel of TLIN2022A-Q1 is transitioning between modes, the device needs the time,  $t_{\text{MODE\_CHANGE}}$ , to allow the change to fully propagate from the EN pin through the channel into the new state. When transitioning from sleep or standby mode to normal mode, the transition time is the sum of  $t_{\text{MODE\_CHANGE}}$  and  $t_{\text{NOMINT}}$ .

## 10 Application Information Disclaimer

---

### Note

Information in the following applications sections is not part of the TI component specification, and TI does not warrant its accuracy or completeness. TI's customers are responsible for determining suitability of components for their purposes, as well as validating and testing their design implementation to confirm system functionality.

---

### 10.1 Application Information

The TLIN2022A-Q1 can be used as both a responder node device and a commander node device in a LIN network. The device comes with the ability to support both remote wake-up request and local wake-up request.

### 10.2 Typical Application

The device comes with an integrated 45 k $\Omega$  pull-up resistor and series diode for responder node applications. For commander node applications, an external 1 k $\Omega$  pull-up resistor with series blocking diode can be used. [Figure 10-1](#) shows the device being used in both commander mode and responder mode applications.



between 1 kΩ to 10 kΩ, depending on supply used (See I<sub>OL</sub> in electrical characteristics). The V<sub>SUP</sub> pin of the device should be decoupled with a 100 nF capacitor by placing it close to the V<sub>SUP</sub> supply pin. The system should include additional decoupling on the V<sub>SUP</sub> line as needed per the application requirements.

## 10.2.2 Detailed Design Procedures

### 10.2.2.1 Normal Mode Application Note

When using the TLIN2022A-Q1 in systems which are monitoring the RXD pin for a wake up request, special care should be taken during the mode transitions. The output of the RXD pin is indeterminate for the transition period between states as the receivers are switched. The application software should not look for an edge on the RXD pin indicating a wake up request until t when going from normal to sleep mode or t<sub>MODE\_CHANGE</sub> plus t<sub>NOMINT</sub> when going from sleep or standby to normal mode. This is shown in [图 8-14](#).

### 10.2.2.2 Standby Mode Application Note

If the TLIN2022A-Q1 detects an undervoltage on V<sub>SUP</sub> the RXD pin transitions low, and signals to the software that the TLIN2022A-Q1 is in standby mode and should be returned to sleep mode for the lowest power state.

### 10.2.2.3 TXD Dominant State Timeout Application Note

The maximum dominant TXD time allowed by the TXD dominant state time out limits the minimum possible data rate of the device. The LIN protocol has different constraints for commander and responder applications thus there are different maximum consecutive dominant bits for each application case and thus different minimum data rates.

## 10.2.3 Application Curves

[图 10-2](#) and [图 10-3](#) show the propagation delay from the TXD pin to the LIN pin for both dominant to recessive and recessive to dominant edges.

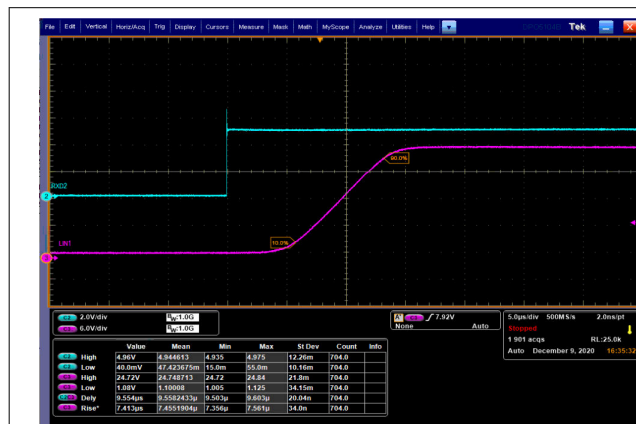

**图 10-2. Dominant to Recessive Propagation**



**图 10-3. Recessive to Dominant Propagation**

## Power Supply Recommendations

The TLIN2022A-Q1 was designed to operate directly off a car battery, or any other DC supply ranging from 4 V to 48 V. A 100 nF decoupling capacitor should be placed as close to the  $V_{SUP}$  pin of the device as possible. It is good practice for some applications with noisier supplies to include 1  $\mu$ F and 10  $\mu$ F decoupling capacitor.

## 11 Layout

In order for the PCB design to be successful, start with the design of the protection and filtering circuitry. Because ESD and EFT transients have a wide frequency bandwidth from approximately 3 MHz to 3 GHz, high frequency layout techniques must be applied during PCB design. Placement at the connector also prevents these noisy events from propagating further into the PCB and system.

### 11.1 Layout Guidelines

- **Pin 1, 4 (RXD1/2):** The pin is an open-drain outputs and require an external pull-up resistor in the range of 1 k $\Omega$  and 10 k $\Omega$  to function properly. If the microprocessor paired with the transceiver does not have an integrated pull-up, an external resistor should be placed between RXD and the regulated voltage supply for the microprocessor.
- **Pin 2, 5 (EN1/2):** EN is an input pin that is used to place the device in a low power sleep mode. If this feature is not used, the pin should be pulled high to the regulated voltage supply of the microprocessor through a series resistor, values between 1 k $\Omega$  and 10 k $\Omega$ . Additionally, a series resistor may be placed on the pin to limit current on the digital lines in the event of an over voltage fault.
- **Pin 6 (NC):** Not Connected.
- **Pin 3, 7 (TXD1/2):** The TXD pins are the transmitter input signals to the device from the processor. A series resistor can be placed to limit the input current to the device in the case of an over-voltage on this pin. A capacitor to ground can be placed close to the input pin of the device to filter noise.
- **Pin 8 (GND):** This is the ground connection for the device. This pin should be tied to the ground plane through a short trace with the use of two vias to limit total return inductance.
- **Pin 9, 13 (LIN1/2):** This pin connects to the LIN bus. For responder node applications, a 220 pF capacitor to ground is implemented. For commander node applications and additional series resistor, a blocking diode should be placed between the LIN pin and the  $V_{SUP}$  pin. See [Figure 10-1](#).
- **Pin 10 ( $V_{SUP}$ ):** This is the supply pin for the device. A 100 nF decoupling capacitor should be placed as close to the device as possible.
- **Pin 11, 12 and 14 (NC):** Not Connected.

---

#### Note

All ground and power connections should be made as short as possible and use at least two vias to minimize the total loop inductance.

---

## 11.2 Layout Example



图 11-1. Layout Example

## 12 Device and Documentation Support

This device will conform to the following LIN standards. The core of what is needed is covered within this system spec, however reference should be made to these standards and any discrepancies pointed out and discussed. This document should provide all the basics of what is needed.

### 12.1 Documentation Support

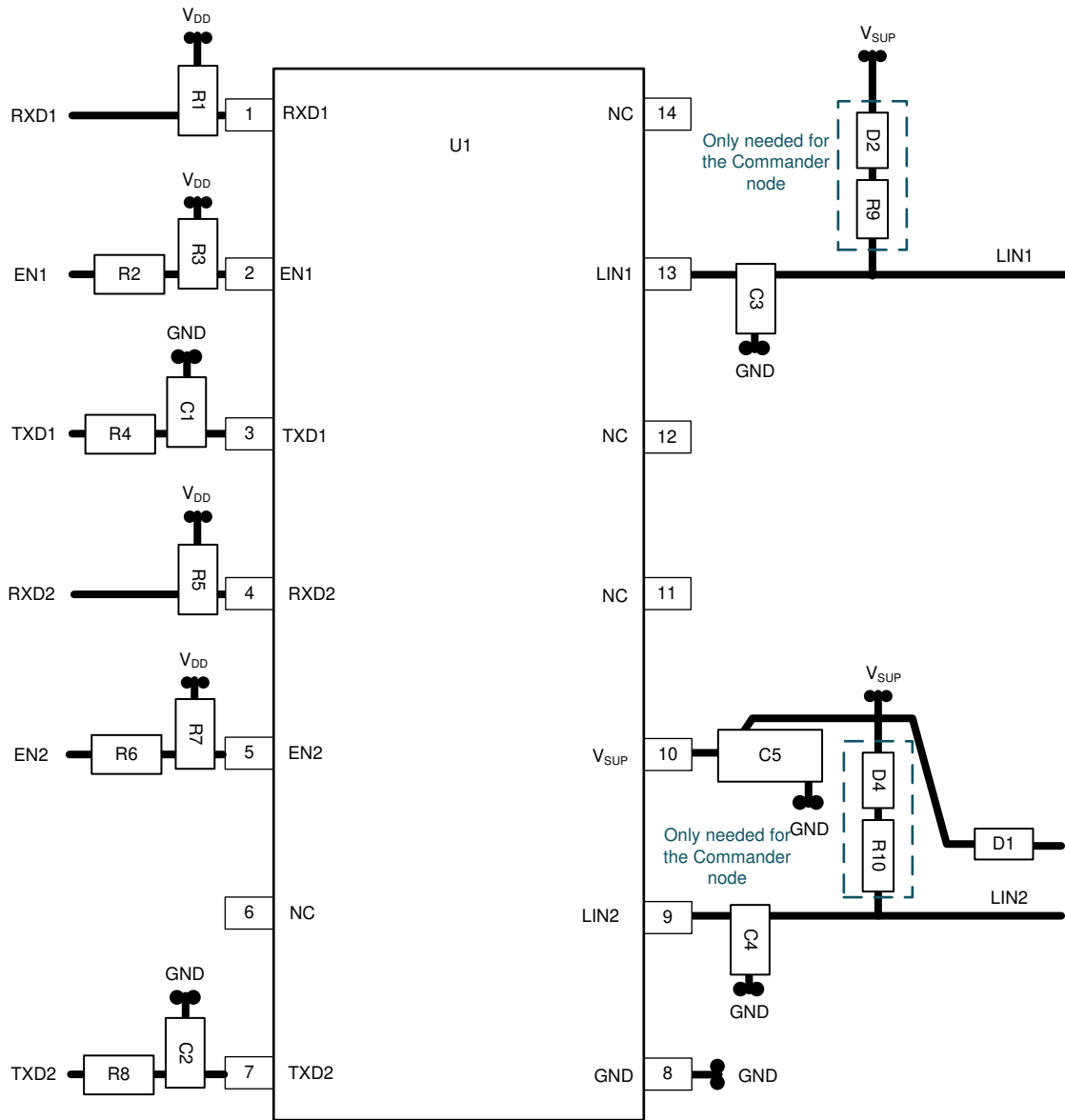
#### 12.1.1 Related Documentation

For related documentation see the following:

- LIN Standards:
  - ISO/DIS 17987-1: Road vehicles -- Local Interconnect Network (LIN) -- Part 1: General information and use case definition
  - ISO/DIS 17987-4: Road vehicles -- Local Interconnect Network (LIN) -- Part 4: Electrical Physical Layer (EPL) specification 12V/24V
  - SAEJ2602-1: LIN Network for Vehicle Applications
  - LIN2.0, LIN2.1, LIN2.2 and LIN2.2A specification
- EMC requirements:
  - SAEJ2962-1
  - ISO 10605: Road vehicles - Test methods for electrical disturbances from electrostatic discharge
  - ISO 11452-4:2011: Road vehicles - Component test methods for electrical disturbances from narrowband radiated electromagnetic energy - Part 4: Harness excitation methods
  - ISO 7637-1:2015: Road vehicles - Electrical disturbances from conduction and coupling - Part 1: Definitions and general considerations
  - ISO 7637-3: Road vehicles - Electrical disturbances from conduction and coupling - Part 3: Electrical transient transmission by capacitive and inductive coupling via lines other than supply lines
  - IEC 62132-4:2006: Integrated circuits - Measurement of electromagnetic immunity 150 kHz to 1 GHz - Part 4: Direct RF power injection method
  - IEC 61000-4-2
  - IEC 61967-4
  - CISPR25
- Conformance Test requirements:
  - ISO/DIS 17987-7: Road vehicles -- Local Interconnect Network (LIN) -- Part 7: Electrical Physical Layer (EPL) conformance test specification
  - SAEJ2602-2: LIN Network for Vehicle Applications Conformance Test
- 

#### 12.2 接收文档更新通知

要接收文档更新通知，请导航至 [ti.com](http://ti.com) 上的器件产品文件夹。点击 [订阅更新](#) 进行注册，即可每周接收产品信息更改摘要。有关更改的详细信息，请查看任何已修订文档中包含的修订历史记录。

#### 12.3 支持资源

[TI E2E™ 支持论坛](#) 是工程师的重要参考资料，可直接从专家获得快速、经过验证的解答和设计帮助。搜索现有解答或提出自己的问题可获得所需的快速设计帮助。

链接的内容由各个贡献者“按原样”提供。这些内容并不构成 TI 技术规范，并且不一定反映 TI 的观点；请参阅 TI 的 [《使用条款》](#)。

#### 12.4 Trademarks

TI E2E™ is a trademark of Texas Instruments.

所有商标均为其各自所有者的财产。

## 12.5 Electrostatic Discharge Caution



This integrated circuit can be damaged by ESD. Texas Instruments recommends that all integrated circuits be handled with appropriate precautions. Failure to observe proper handling and installation procedures can cause damage.

ESD damage can range from subtle performance degradation to complete device failure. Precision integrated circuits may be more susceptible to damage because very small parametric changes could cause the device not to meet its published specifications.

## 12.6 Glossary

[TI Glossary](#) This glossary lists and explains terms, acronyms, and definitions.

## 13 Mechanical, Packaging, and Orderable Information

The following pages include mechanical, packaging, and orderable information. This information is the most current data available for the designated devices. This data is subject to change without notice and revision of this document. For browser-based versions of this data sheet, refer to the left-hand navigation.

**PACKAGING INFORMATION**

Orderable Device	Status (1)	Package Type	Package Drawing	Pins	Package Qty	Eco Plan (2)	Lead finish/ Ball material (6)	MSL Peak Temp (3)	Op Temp (°C)	Device Marking (4/5)	Samples
TLIN2022ADMTRQ1	ACTIVE	VSON	DMT	14	3000	RoHS & Green	SN	Level-2-260C-1 YEAR	-40 to 125	T022A	<a href="#">Samples</a>
TLIN2022ADRQ1	ACTIVE	SOIC	D	14	2500	RoHS & Green	NIPDAUAG	Level-1-260C-UNLIM	-40 to 125	TL022A	<a href="#">Samples</a>

(1) The marketing status values are defined as follows:

**ACTIVE:** Product device recommended for new designs.

**LIFEBUY:** TI has announced that the device will be discontinued, and a lifetime-buy period is in effect.

**NRND:** Not recommended for new designs. Device is in production to support existing customers, but TI does not recommend using this part in a new design.

**PREVIEW:** Device has been announced but is not in production. Samples may or may not be available.

**OBSOLETE:** TI has discontinued the production of the device.

(2) **RoHS:** TI defines "RoHS" to mean semiconductor products that are compliant with the current EU RoHS requirements for all 10 RoHS substances, including the requirement that RoHS substance do not exceed 0.1% by weight in homogeneous materials. Where designed to be soldered at high temperatures, "RoHS" products are suitable for use in specified lead-free processes. TI may reference these types of products as "Pb-Free".

**RoHS Exempt:** TI defines "RoHS Exempt" to mean products that contain lead but are compliant with EU RoHS pursuant to a specific EU RoHS exemption.

**Green:** TI defines "Green" to mean the content of Chlorine (Cl) and Bromine (Br) based flame retardants meet JS709B low halogen requirements of <=1000ppm threshold. Antimony trioxide based flame retardants must also meet the <=1000ppm threshold requirement.

(3) MSL, Peak Temp. - The Moisture Sensitivity Level rating according to the JEDEC industry standard classifications, and peak solder temperature.

(4) There may be additional marking, which relates to the logo, the lot trace code information, or the environmental category on the device.

(5) Multiple Device Markings will be inside parentheses. Only one Device Marking contained in parentheses and separated by a "~" will appear on a device. If a line is indented then it is a continuation of the previous line and the two combined represent the entire Device Marking for that device.

(6) Lead finish/Ball material - Orderable Devices may have multiple material finish options. Finish options are separated by a vertical ruled line. Lead finish/Ball material values may wrap to two lines if the finish value exceeds the maximum column width.

**Important Information and Disclaimer:**The information provided on this page represents TI's knowledge and belief as of the date that it is provided. TI bases its knowledge and belief on information provided by third parties, and makes no representation or warranty as to the accuracy of such information. Efforts are underway to better integrate information from third parties. TI has taken and continues to take reasonable steps to provide representative and accurate information but may not have conducted destructive testing or chemical analysis on incoming materials and chemicals. TI and TI suppliers consider certain information to be proprietary, and thus CAS numbers and other limited information may not be available for release.

In no event shall TI's liability arising out of such information exceed the total purchase price of the TI part(s) at issue in this document sold by TI to Customer on an annual basis.



## GENERIC PACKAGE VIEW

**DMT 14**

**VSON - 0.9 mm max height**

3 x 4.5, 0.65 mm pitch

PLASTIC SMALL OUTLINE - NO LEAD

This image is a representation of the package family, actual package may vary.  
Refer to the product data sheet for package details.

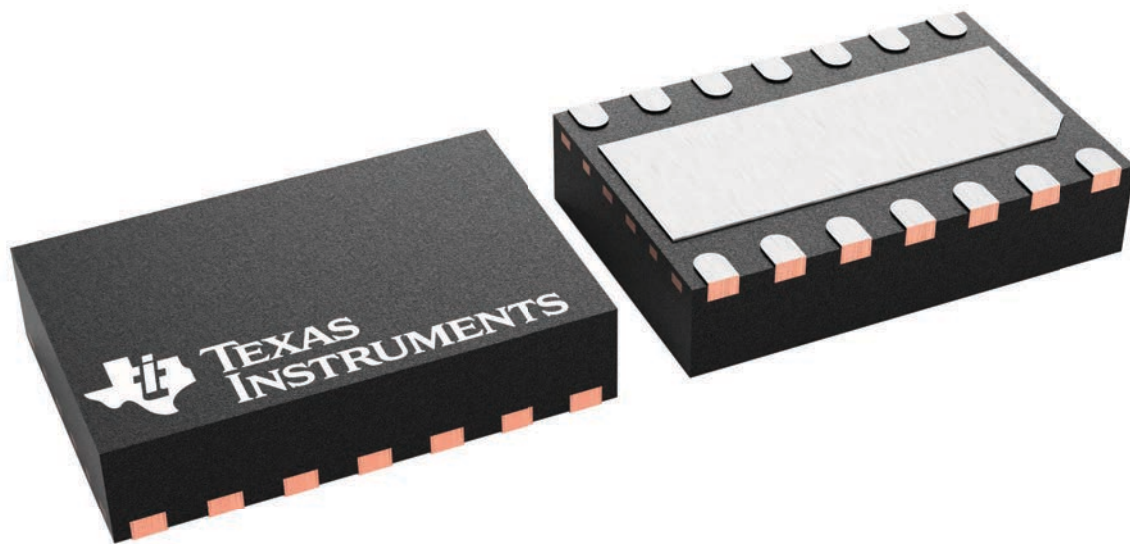

4225088/A

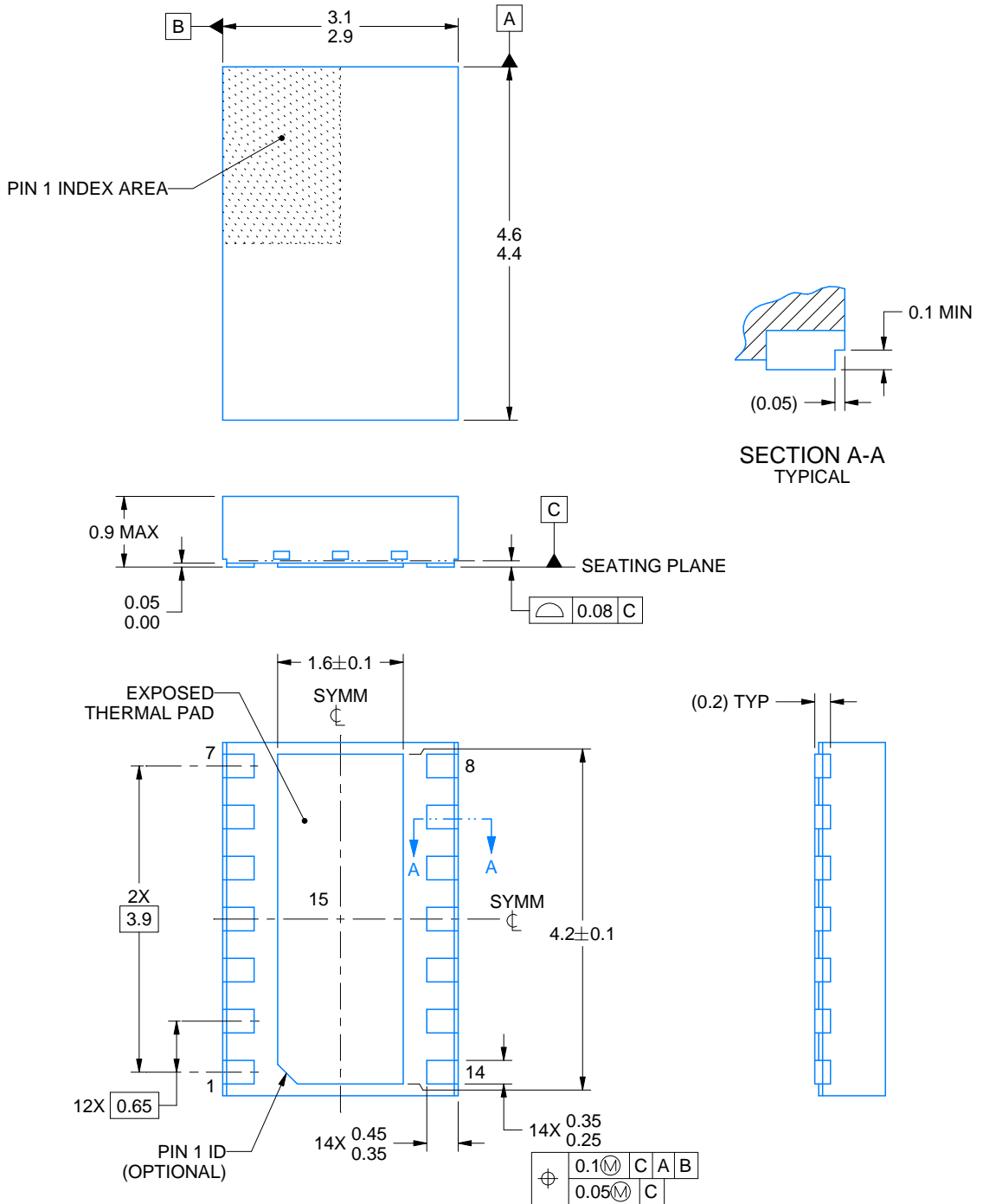

4223033/B 10/2016

NOTES:

1. All linear dimensions are in millimeters. Any dimensions in parenthesis are for reference only. Dimensioning and tolerancing per ASME Y14.5M.
2. This drawing is subject to change without notice.
3. The package thermal pad must be soldered to the printed circuit board for thermal and mechanical performance.

# EXAMPLE BOARD LAYOUT

DMT0014A

VSON - 0.9 mm max height

PLASTIC SMALL OUTLINE - NO LEAD

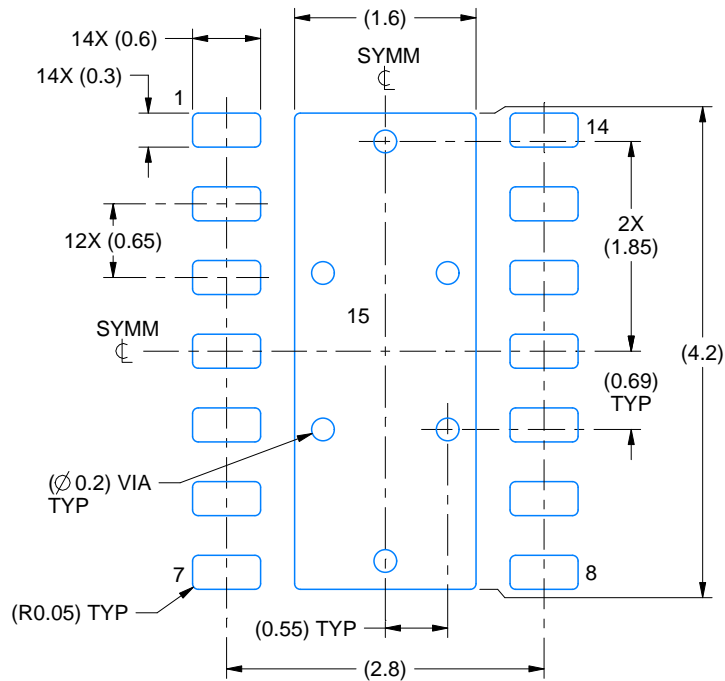

LAND PATTERN EXAMPLE  
SCALE:15X

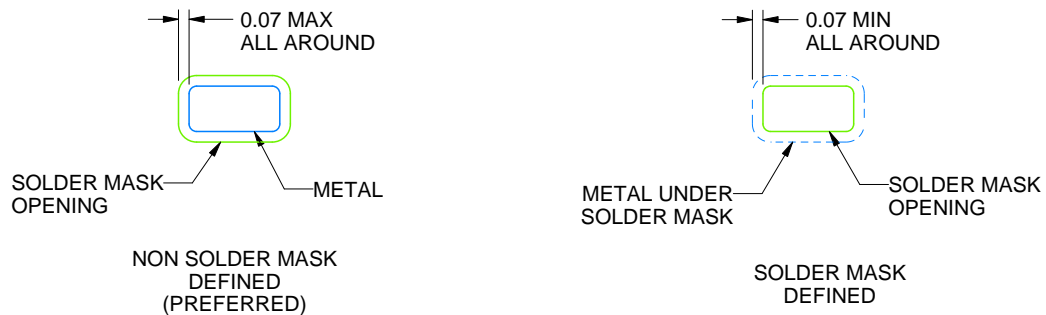

SOLDER MASK DETAILS

4223033/B 10/2016

NOTES: (continued)

4. This package is designed to be soldered to a thermal pad on the board. For more information, see Texas Instruments literature number SLUA271 ([www.ti.com/lit/slua271](http://www.ti.com/lit/slua271)).
5. Vias are optional depending on application, refer to device data sheet. If any vias are implemented, refer to their locations shown on this view. It is recommended that vias under paste be filled, plugged or tented.

# EXAMPLE STENCIL DESIGN

DMT0014A

VSON - 0.9 mm max height

PLASTIC SMALL OUTLINE - NO LEAD

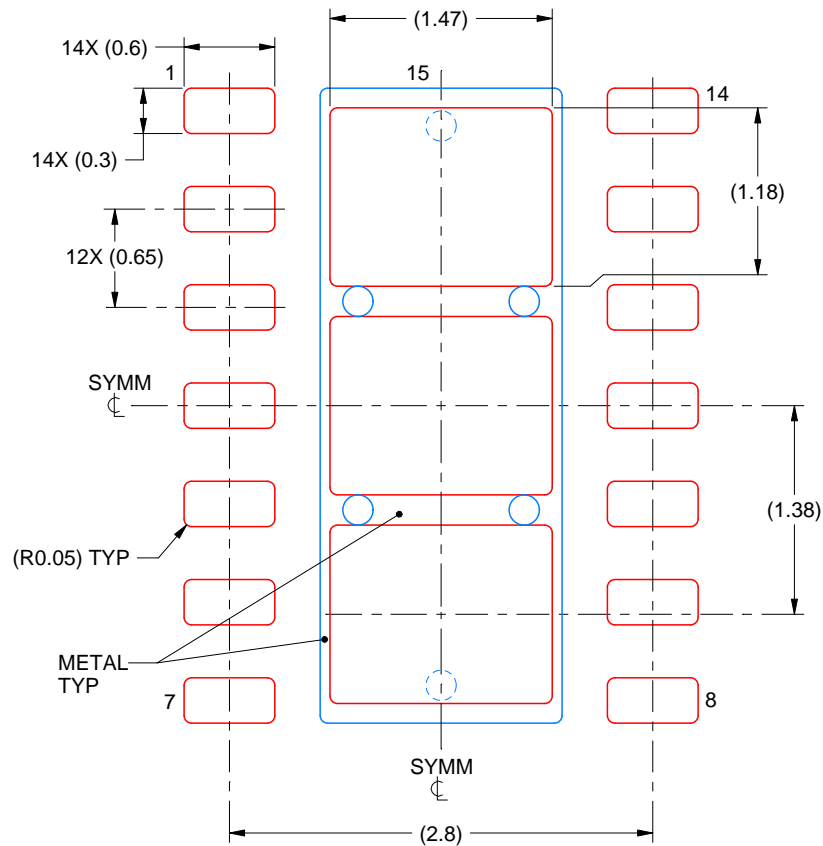

SOLDER PASTE EXAMPLE  
BASED ON 0.125 mm THICK STENCIL  
EXPOSED PAD 15  
77.4% PRINTED SOLDER COVERAGE BY AREA  
SCALE:20X

4223033/B 10/2016



NOTES: (continued)

6. Laser cutting apertures with trapezoidal walls and rounded corners may offer better paste release. IPC-7525 may have alternate design recommendations.

D (R-PDSO-G14)

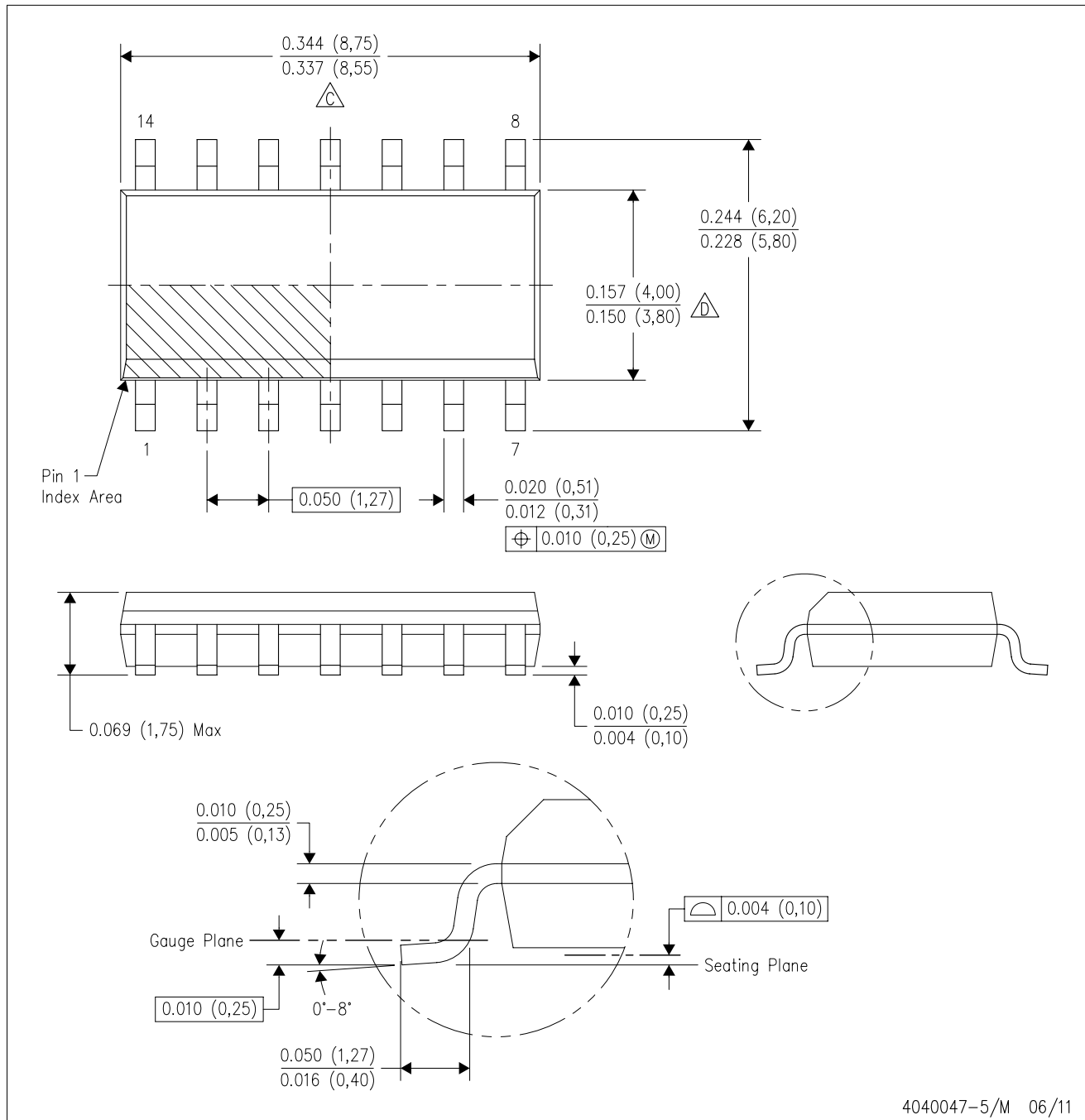
PLASTIC SMALL OUTLINE



- NOTES:
- A. All linear dimensions are in inches (millimeters).
  - B. This drawing is subject to change without notice.
  -  Body length does not include mold flash, protrusions, or gate burrs. Mold flash, protrusions, or gate burrs shall not exceed 0.006 (0,15) each side.
  -  Body width does not include interlead flash. Interlead flash shall not exceed 0.017 (0,43) each side.
  - E. Reference JEDEC MS-012 variation AB.

## 重要声明和免责声明

TI 提供技术和可靠性数据（包括数据表）、设计资源（包括参考设计）、应用或其他设计建议、网络工具、安全信息和其他资源，不保证没有瑕疵且不做任何明示或暗示的担保，包括但不限于对适销性、某特定用途方面的适用性或不侵犯任何第三方知识产权的暗示担保。

这些资源可供使用 TI 产品进行设计的熟练开发人员使用。您将自行承担以下全部责任：(1) 针对您的应用选择合适的 TI 产品，(2) 设计、验证并测试您的应用，(3) 确保您的应用满足相应标准以及任何其他安全、安保或其他要求。这些资源如有变更，恕不另行通知。TI 授权您仅可将这些资源用于研发本资源所述的 TI 产品的应用。严禁对这些资源进行其他复制或展示。您无权使用任何其他 TI 知识产权或任何第三方知识产权。您应全额赔偿因在这些资源的使用中对 TI 及其代表造成的任何索赔、损害、成本、损失和债务，TI 对此概不负责。

TI 提供的产品受 TI 的销售条款 (<https://www.ti.com.cn/zh-cn/legal/termsofsale.html>) 或 [ti.com.cn](https://www.ti.com.cn) 上其他适用条款/TI 产品随附的其他适用条款的约束。TI 提供这些资源并不会扩展或以其他方式更改 TI 针对 TI 产品发布的适用的担保或担保免责声明。

邮寄地址：上海市浦东新区世纪大道 1568 号中建大厦 32 楼，邮政编码：200122  
Copyright © 2021 德州仪器半导体技术（上海）有限公司