

SN6501-Q1 Transformer Driver for Isolated Power Supplies

1 Features

- Qualified for Automotive Applications
- AEC-Q100 Qualified With the Following Results
 - Device Temperature Grade 1: -40°C to 125°C Ambient Operating Temperature Range
 - Device HBM ESD Classification Level H2
 - Device CDM ESD Classification Level C4B
- **Functional Safety-Capable**
 - [Documentation available to aid functional safety system design](#)
- Push-Pull Driver for Small Transformers
- Single 3.3-V or 5-V Supply
- High Primary-side Current Drive:
 - 5-V Supply: 350 mA (Max)
 - 3.3-V Supply: 150 mA (Max)
- Low Ripple on Rectified Output Permits Small Output Capacitors
- Small 5-Pin SOT-23 Package

2 Applications

- Isolated Interface Power Supply for CAN, RS-485, RS-422, RS-232, SPI, I2C, Low-Power LAN
- Industrial Automation
- Process Control
- Medical Equipment

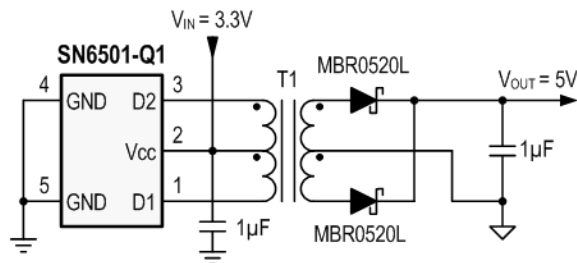

Simplified Schematic

3 Description

The SN6501-Q1 is a monolithic oscillator/power-driver, specifically designed for small form factor, isolated power supplies in isolated interface applications. The device drives a low-profile, center-tapped transformer primary from a 3.3-V or 5-V DC power supply. The secondary can be wound to provide any isolated voltage based on transformer turns ratio.

The SN6501-Q1 consists of an oscillator followed by a gate drive circuit that provides the complementary output signals to drive the ground referenced N-channel power switches. The internal logic ensures break-before-make action between the two switches.

The SN6501-Q1 is available in a small SOT-23 (5) package, and is specified for operation at temperatures from -40°C to 125°C .

Device Information

PART NUMBER ⁽¹⁾	PACKAGE	BODY SIZE (NOM)
SN6501-Q1	SOT-23 (5)	2.90 mm x 1.60 mm

- (1) For all available packages, see the orderable addendum at the end of the datasheet.

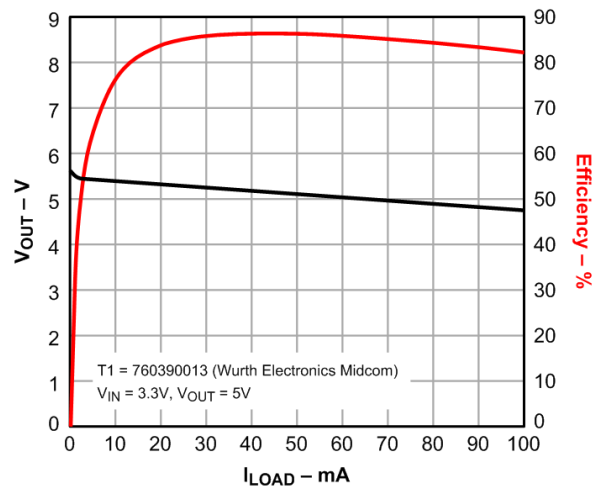

Output Voltage and Efficiency vs Output Current



5 Pin Configuration and Functions

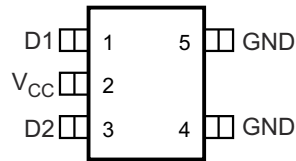

Figure 5-1. 5-Pin SOT-23 DBV Package Top View

Table 5-1. Pin Functions

PIN			DESCRIPTION
NAME	NUMBER	TYPE	
D1	1	OD	Open Drain output 1. Connect this pin to one end of the transformer primary side.
V _{CC}	2	P	Supply voltage input. Connect this pin to the center-tap of the transformer primary side. Buffer this voltage with a 1 μ F to 10 μ F ceramic capacitor.
D2	3	OD	Open Drain output 2. Connect this pin to the other end of the transformer primary side.
GND	4,5	P	Device ground. Connect this pin to board ground.

Table of Contents

1 Features	1	8.3 Feature Description	12
2 Applications	1	8.4 Device Functional Modes	13
3 Description	1	9 Application and Implementation	14
4 Revision History	3	9.1 Application Information.....	14
5 Pin Configuration and Functions	2	9.2 Typical Application.....	15
6 Specifications	4	10 Power Supply Recommendations	27
6.1 Absolute Maximum Ratings.....	4	11 Layout	28
6.2 Handling Ratings.....	4	11.1 Layout Guidelines.....	28
6.3 Recommended Operating Conditions.....	5	11.2 Layout Example.....	28
6.4 Thermal Information.....	5	12 Device and Documentation Support	29
6.5 Electrical Characteristics.....	5	12.1 Device Support.....	29
6.6 Switching Characteristics.....	5	12.2 Trademarks.....	29
6.7 Typical Characteristics.....	6	12.3 Electrostatic Discharge Caution.....	29
7 Parameter Measurement Information	11	12.4 Glossary.....	29
8 Detailed Description	12	13 Mechanical, Packaging, and Orderable Information	29
8.1 Overview.....	12		
8.2 Functional Block Diagram.....	12		

4 Revision History

NOTE: Page numbers for previous revisions may differ from page numbers in the current version.

Changes from Revision B (October 2020) to Revision C (March 2021)	Page
• Changed the f_{OSC} Oscillator frequency values	5
• Added a short-circuit protection note to SN6501 Drive Capability	15
• Changed Equation 4	18
• Removed duplicate equation labeled as (5) in Revision B.....	18
• Added 17 line items to Recommended Isolation Transformers Optimized for SN6501	20

Changes from Revision A (September 2014) to Revision B (October 2020)	Page
• Added Functional Safety Bullets.....	1

Changes from Revision * (June 2013) to Revision A (September 2014)	Page
• Added <i>Pin Configuration and Functions</i> section, <i>Handling Rating</i> table, <i>Feature Description</i> section, <i>Device Functional Modes</i> , <i>Application and Implementation</i> section, <i>Power Supply Recommendations</i> section, <i>Layout</i> section, <i>Device and Documentation Support</i> section, and <i>Mechanical, Packaging, and Orderable Information</i> section	1
• Changed Equation 10	18
• Changed Equation 11	18
• Changed Table 9-4 , From: Wuerth-Elektronik / Midcom To: Wurth Electronics Midcom Inc.....	22
• Changed Figure 9-16	22

6 Specifications

6.1 Absolute Maximum Ratings

over operating free-air temperature range (unless otherwise noted)⁽¹⁾

		MIN	MAX	UNIT
V _{CC}	Supply voltage	-0.3	6	V
V _{D1} , V _{D2}	Output switch voltage		14	V
I _{D1P} , I _{D2P}	Peak output switch current		500	mA
P _{TOT}	Continuous power dissipation		250	mW
T _J	Junction temperature		170	°C

- (1) Stresses beyond those listed under Absolute Maximum Ratings cause permanent damage to the device. These are stress ratings only and functional operation of the device at these or any other conditions beyond those indicated under [Section 6.3](#) is not implied. Exposure to absolute-maximum-rated conditions for extended periods affects device reliability.

6.2 Handling Ratings

		MIN	MAX	UNIT
T _{stg}	Storage temperature range	-65	150	°C
V _(ESD)	Electrostatic discharge	Human body model (HBM) AEC-Q100 Classification Level H2, all pins		kV
		Charged device model (CDM) AEC-Q100 Classification Level C4B, all pins		V

6.3 Recommended Operating Conditions

			MIN	TYP	MAX	UNIT
V _{CC}	Supply voltage		3		5.5	V
V _{D1} , V _{D2}	Output switch voltage	V _{CC} = 5 V ± 10%,	0		11	V
		V _{CC} = 3.3 V ± 10%	0		7.2	
I _{D1} , I _{D2}	D1 and D2 output switch current – Primary-side	V _{CC} = 5 V ± 10%			350	mA
		V _{CC} = 3.3 V ± 10%			150	
T _A	Ambient temperature		-40		125	°C

6.4 Thermal Information

THERMAL METRIC ⁽¹⁾		SN6501	UNIT
		DBV 5-PINS	
θ _{JA}	Junction-to-ambient thermal resistance	208.3	°C/W
θ _{JCtop}	Junction-to-case (top) thermal resistance	87.1	
θ _{JB}	Junction-to-board thermal resistance	40.4	
ψ _{JT}	Junction-to-top characterization parameter	5.2	
ψ _{JB}	Junction-to-board characterization parameter	39.7	
θ _{JCbot}	Junction-to-case (bottom) thermal resistance	N/A	

(1) For more information about traditional and new thermal metrics, see the *Semiconductor and IC Package Thermal Metrics* application report ([SPRA953](#)).

6.5 Electrical Characteristics

over full-range of recommended operating conditions, unless otherwise noted

PARAMETER	TEST CONDITIONS	MIN	TYP	MAX	UNIT
R _{ON}	V _{CC} = 3.3 V ± 10%, See Figure 7-4		1	3	Ω
	V _{CC} = 5 V ± 10%, See Figure 7-4		0.6	2	
I _{CC}	V _{CC} = 3.3 V ± 10%, no load		150	400	μA
	V _{CC} = 5 V ± 10%, no load		300	700	
f _{ST}	V _{CC} = 2.4 V, See Figure 7-4		300		kHz
f _{SW}	V _{CC} = 3.3 V ± 10%, See Figure 7-4	250	360	495	kHz
	V _{CC} = 5 V ± 10%, See Figure 7-4	300	410	620	

(1) Average supply current is the current used by SN6501 only. It does not include load current.

6.6 Switching Characteristics

over operating free-air temperature range (unless otherwise noted)

PARAMETER	TEST CONDITIONS	MIN	TYP	MAX	UNIT
t _{r-D}	V _{CC} = 3.3 V ± 10%, See Figure 7-4		70		ns
	V _{CC} = 5 V ± 10%, See Figure 7-4		80		
t _{f-D}	V _{CC} = 3.3 V ± 10%, See Figure 7-4		110		ns
	V _{CC} = 5 V ± 10%, See Figure 7-4		60		
t _{BBM}	V _{CC} = 3.3 V ± 10%, See Figure 7-4		150		ns
	V _{CC} = 5 V ± 10%, See Figure 7-4		50		

6.7 Typical Characteristics

TP1 Curves are measured with the Circuit in [Figure 7-1](#); whereas, TP1 and TP2 Curves are measured with Circuit in [Figure 7-3](#) ($T_A = 25^\circ\text{C}$ unless otherwise noted). See [Table 9-3](#) for Transformer Specifications.

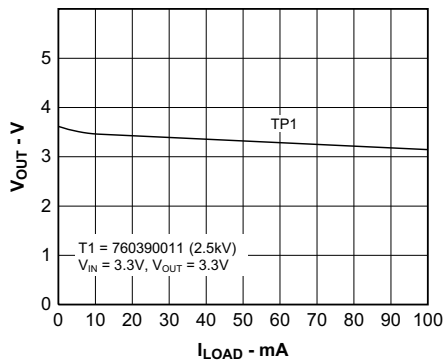

Figure 6-1. Output Voltage vs Load Current

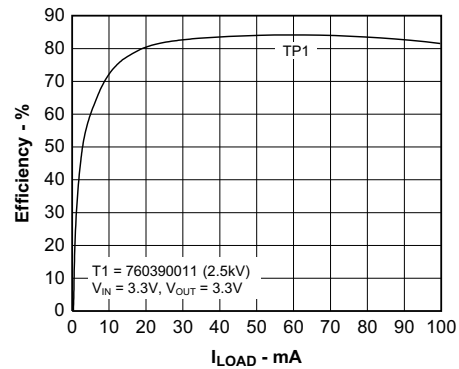

Figure 6-2. Efficiency vs Load Current

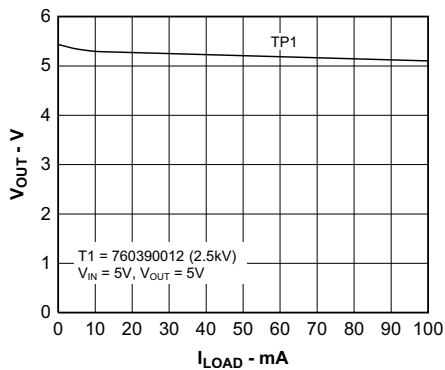

Figure 6-3. Output Voltage vs. Load Current

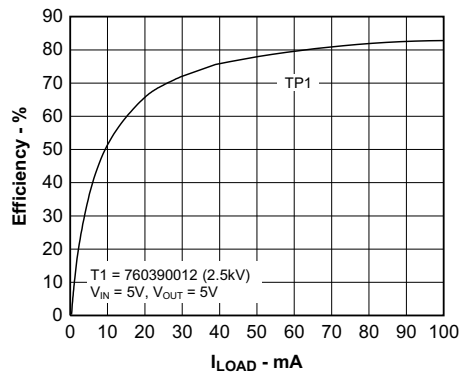

Figure 6-4. Efficiency vs Load Current

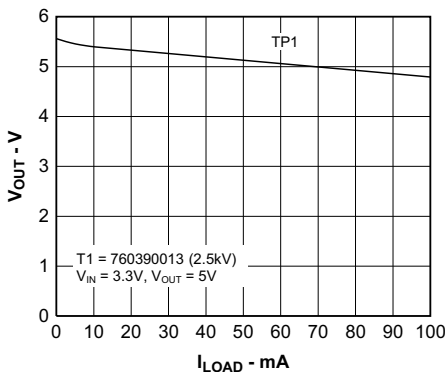

Figure 6-5. Output Voltage vs Load Current

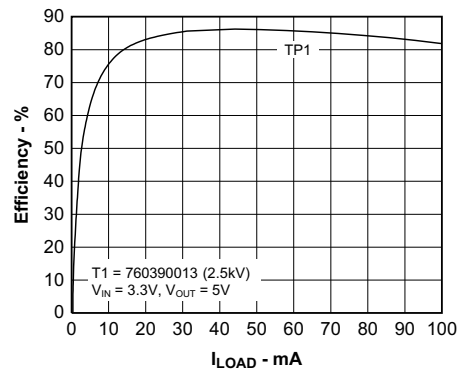

Figure 6-6. Efficiency vs Load Current

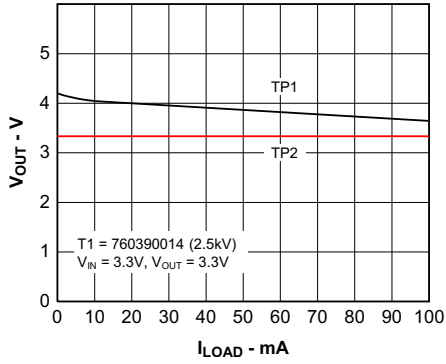

Figure 6-7. Output Voltage vs Load Current

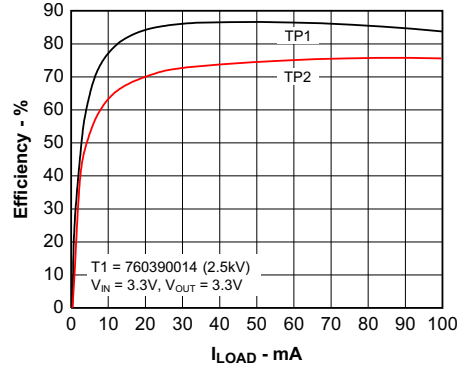

Figure 6-8. Efficiency vs Load Current

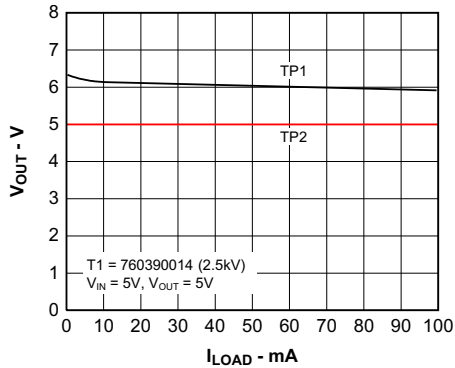

Figure 6-9. Output Voltage vs Load Current

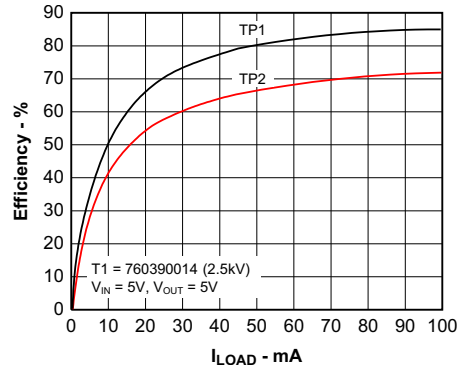

Figure 6-10. Efficiency vs Load Current

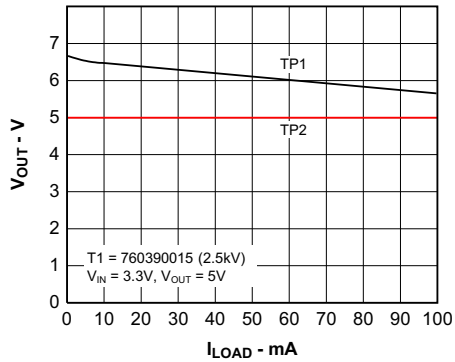

Figure 6-11. Output Voltage vs Load Current

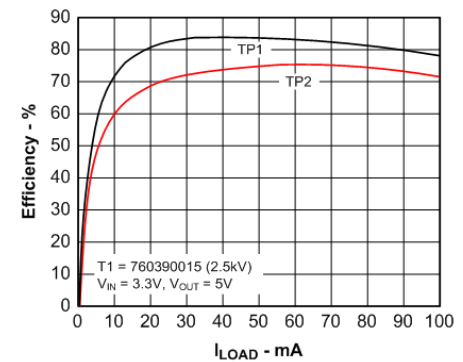

Figure 6-12. Efficiency vs Load Current

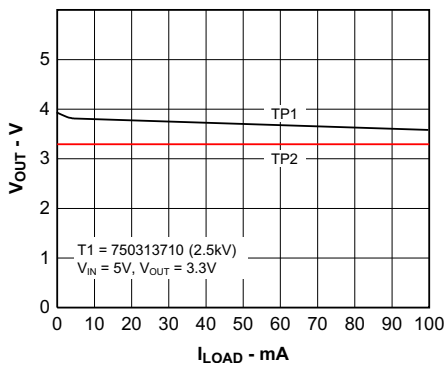

Figure 6-13. Output Voltage vs Load Current

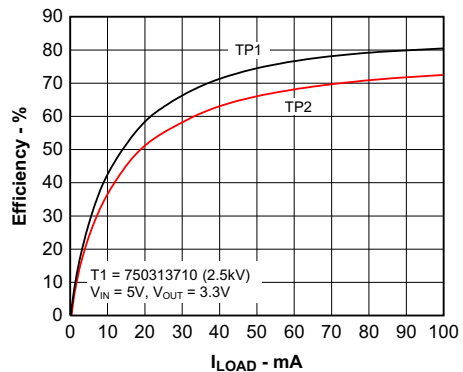

Figure 6-14. Efficiency vs Load Current

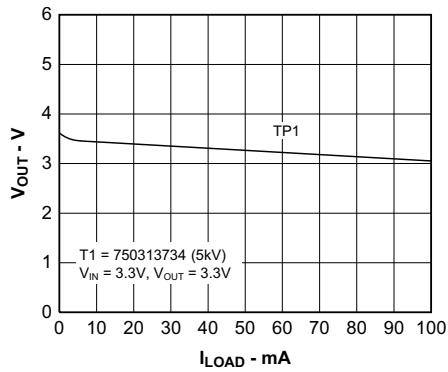

Figure 6-15. Output Voltage vs Load Current

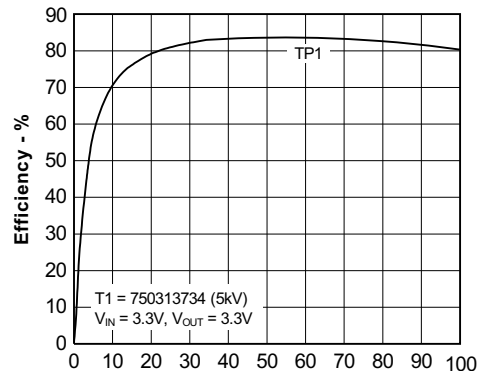

Figure 6-16. Efficiency vs Load Current

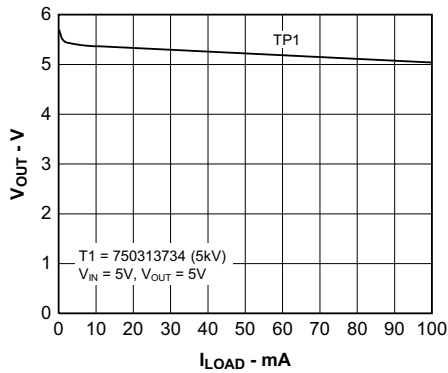

Figure 6-17. Output Voltage vs Load Current

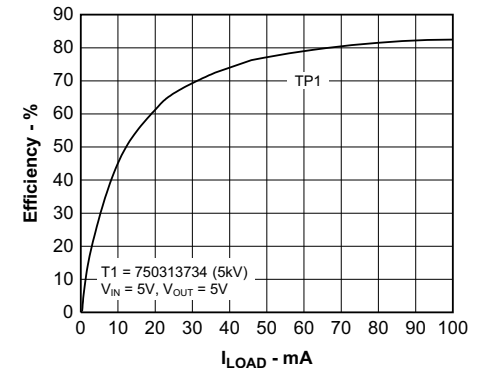

Figure 6-18. Efficiency vs Load Current

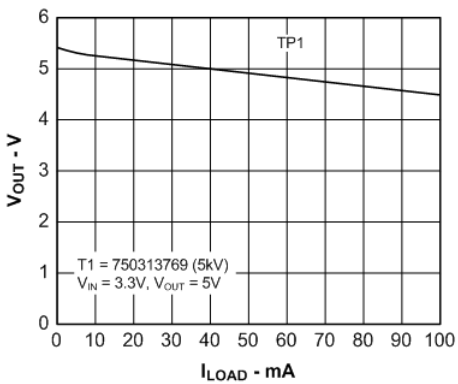

Figure 6-19. Output Voltage vs Load Current

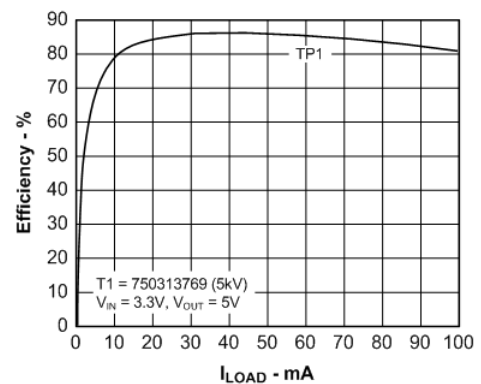

Figure 6-20. Efficiency vs Load Current

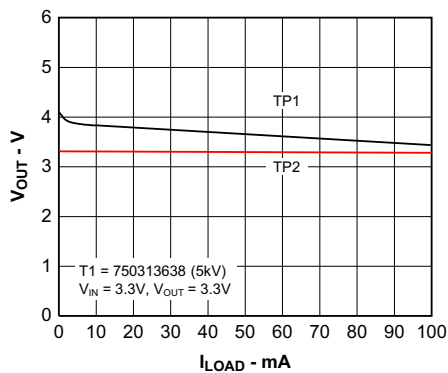

Figure 6-21. Output Voltage vs Load Current

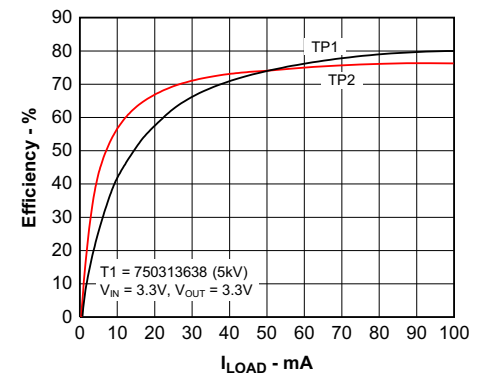

Figure 6-22. Efficiency vs Load Current

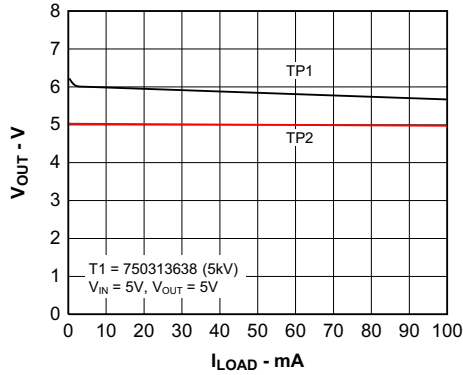

Figure 6-23. Output Voltage vs Load Current

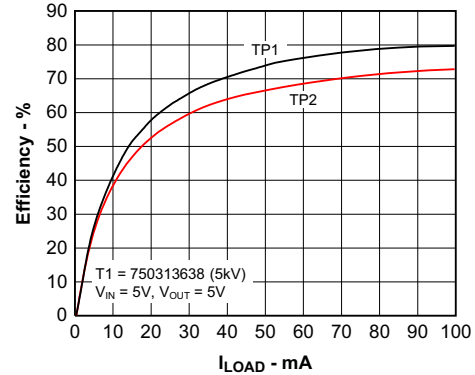

Figure 6-24. Efficiency vs Load Current

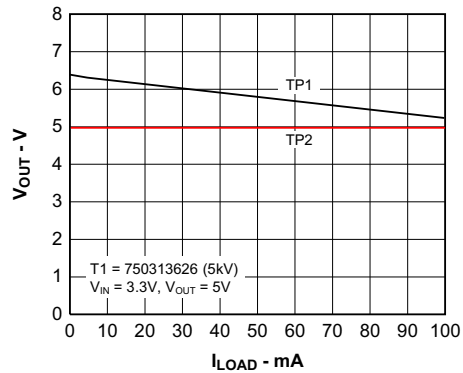

Figure 6-25. Output Voltage vs Load Current

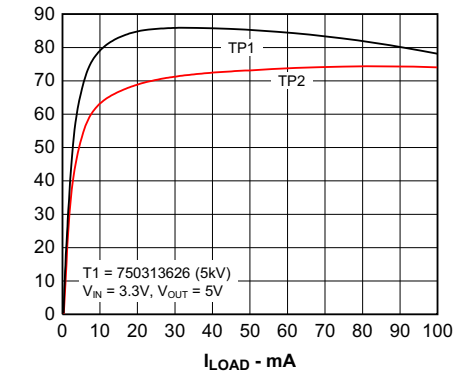

Figure 6-26. Efficiency vs Load Current

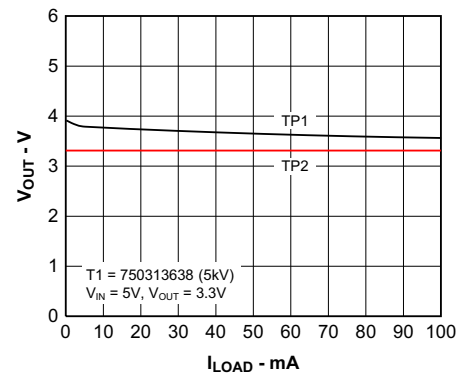

Figure 6-27. Output Voltage vs Load Current

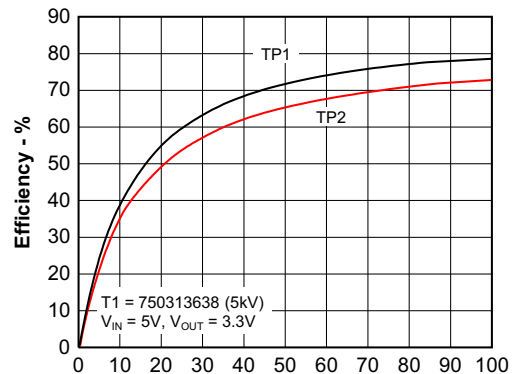

Figure 6-28. Efficiency vs Load Current

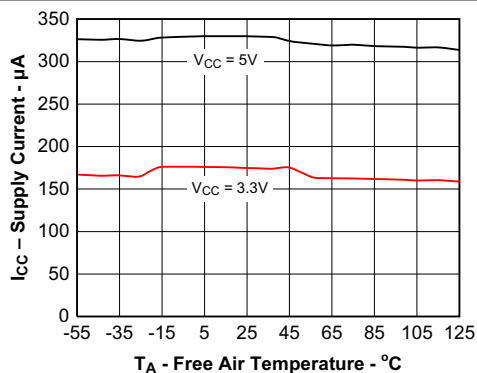

Figure 6-29. Average Supply Current vs Free-Air Temperature

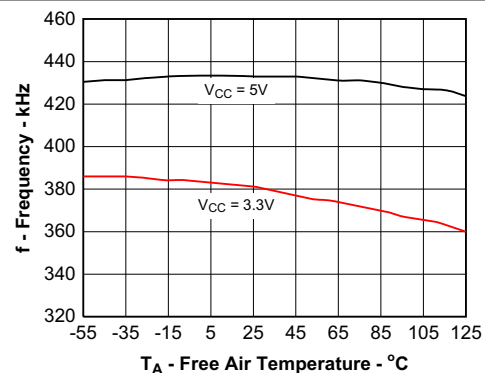

Figure 6-30. D1, D2 Switching Frequency vs Free-Air Temperature

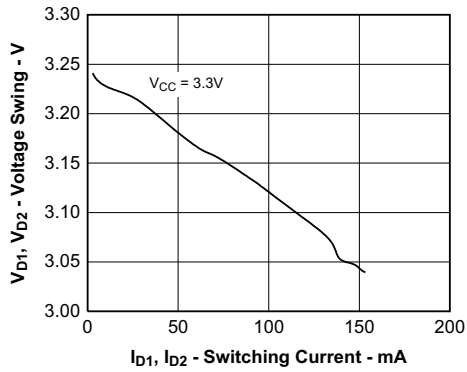

Figure 6-31. D1, D2 Primary-Side Output Switch Voltage Swing vs Current

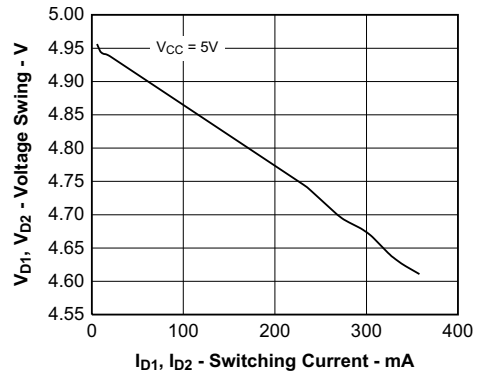

Figure 6-32. D1, D2 Primary-Side Output Switch Voltage Swing vs Current

7 Parameter Measurement Information

7.1

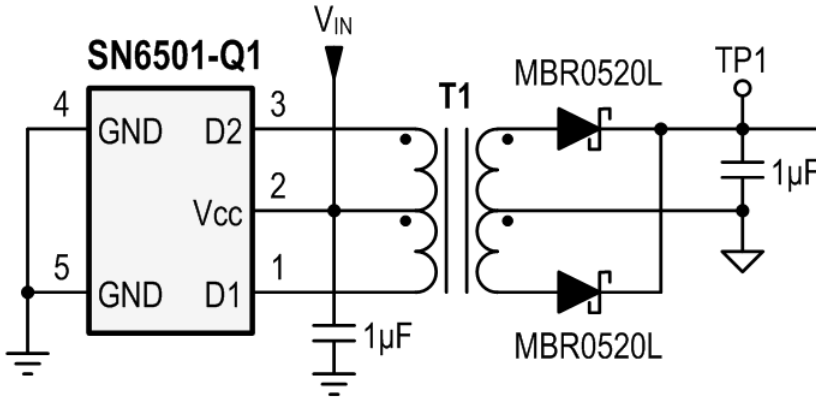

Figure 7-1. Measurement Circuit for Unregulated Output (TP1)

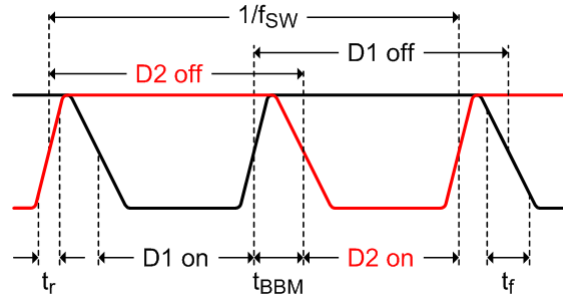

Figure 7-2. Timing Diagram

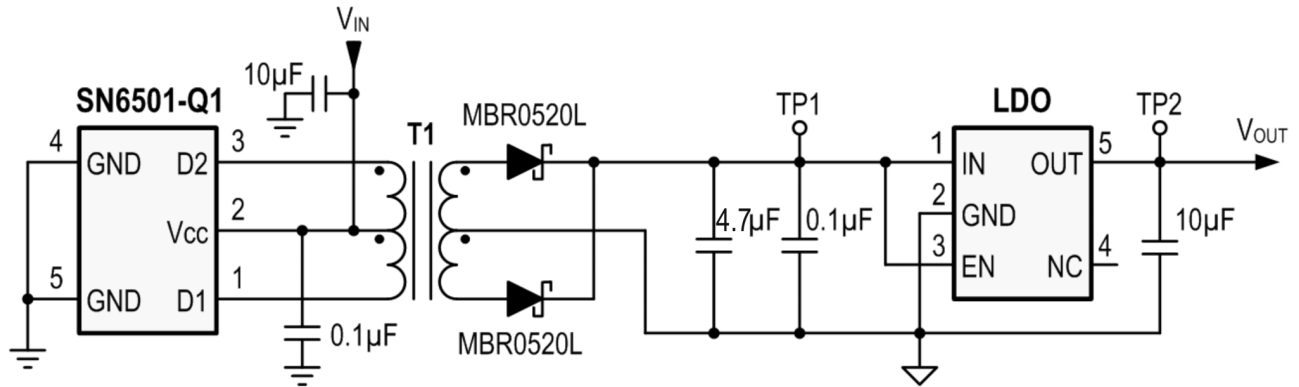

Figure 7-3. Measurement Circuit for regulated Output (TP1 and TP2)

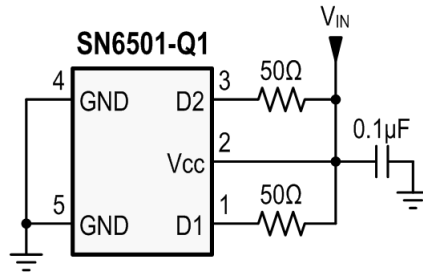

Figure 7-4. Test Circuit For R_{ON} , F_{SW} , F_{St} , T_{r-D} , T_{f-D} , T_{BDM}

8 Detailed Description

8.1 Overview

The SN6501-Q1 is a transformer driver designed for low-cost, small form-factor, isolated DC-DC converters utilizing the push-pull topology. The device includes an oscillator that feeds a gate-drive circuit. The gate-drive, comprising a frequency divider and a break-before-make (BBM) logic, provides two complementary output signals which alternately turn the two output transistors on and off.

The output frequency of the oscillator is divided down by an asynchronous divider that provides two complementary output signals with a 50% duty cycle. A subsequent break-before-make logic inserts a dead-time between the high-pulses of the two signals. The resulting output signals, present the gate-drive signals for the output transistors. As shown in the functional block diagram, before either one of the gates can assume logic high, there must be a short time period during which both signals are low and both transistors are high-impedance. This short period, known as break-before-make time, is required to avoid shorting out both ends of the primary.

8.2 Functional Block Diagram

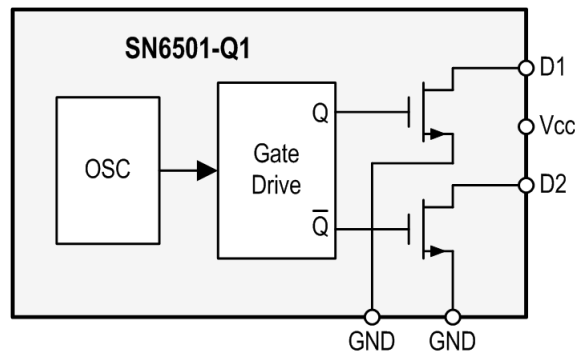

8.3 Feature Description

8.3.1 Push-Pull Converter

Push-pull converters require transformers with center-taps to transfer power from the primary to the secondary (see Figure 8-1).

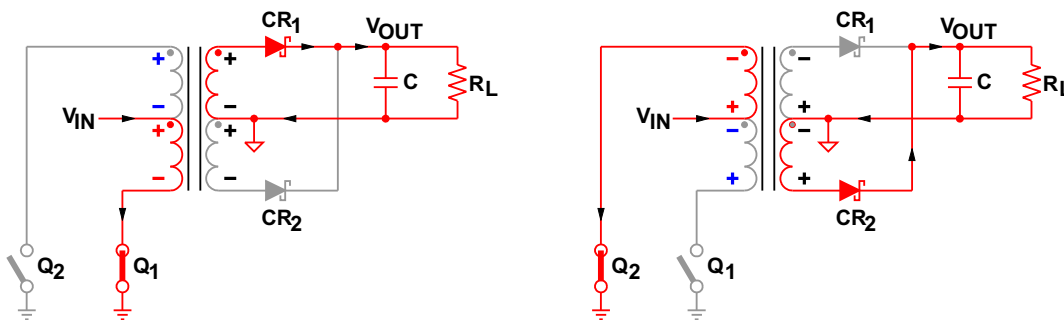

Figure 8-1. Switching Cycles of a Push-Pull Converter

When Q_1 conducts, V_{IN} drives a current through the lower half of the primary to ground, thus creating a negative voltage potential at the lower primary end with regards to the V_{IN} potential at the center-tap.

At the same time the voltage across the upper half of the primary is such that the upper primary end is positive with regards to the center-tap in order to maintain the previously established current flow through Q_2 , which now has turned high-impedance. The two voltage sources, each of which equaling V_{IN} , appear in series and cause a voltage potential at the open end of the primary of $2 \times V_{IN}$ with regards to ground.

Per dot convention the same voltage polarities that occur at the primary also occur at the secondary. The positive potential of the upper secondary end therefore forward biases diode CR_1 . The secondary current

starting from the upper secondary end flows through CR₁, charges capacitor C, and returns through the load impedance R_L back to the center-tap.

When Q₂ conducts, Q₁ goes high-impedance and the voltage polarities at the primary and secondary reverse. Now the lower end of the primary presents the open end with a 2×V_{IN} potential against ground. In this case CR₂ is forward biased while CR₁ is reverse biased and current flows from the lower secondary end through CR₂, charging the capacitor and returning through the load to the center-tap.

8.3.2 Core Magnetization

Figure 8-2 shows the ideal magnetizing curve for a push-pull converter with B as the magnetic flux density and H as the magnetic field strength. When Q₁ conducts the magnetic flux is pushed from A to A', and when Q₂ conducts the flux is pulled back from A' to A. The difference in flux and thus in flux density is proportional to the product of the primary voltage, V_P, and the time, t_{ON}, it is applied to the primary: $B \approx V_P \times t_{ON}$.

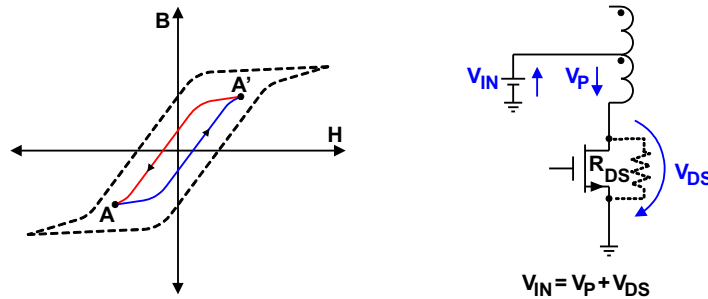

Figure 8-2. Core Magnetization and Self-Regulation Through Positive Temperature Coefficient of R_{DS(on)}

This volt-seconds (V-t) product is important as it determines the core magnetization during each switching cycle. If the V-t products of both phases are not identical, an imbalance in flux density swing results with an offset from the origin of the B-H curve. If balance is not restored, the offset increases with each following cycle and the transformer slowly creeps toward the saturation region.

Fortunately, due to the positive temperature coefficient of a MOSFET's on-resistance, the output FETs of the SN6501 have a self-correcting effect on V-t imbalance. In the case of a slightly longer on-time, the prolonged current flow through a FET gradually heats the transistor which leads to an increase in R_{DS-on}. The higher resistance then causes the drain-source voltage, V_{DS}, to rise. Because the voltage at the primary is the difference between the constant input voltage, V_{IN}, and the voltage drop across the MOSFET, $V_P = V_{IN} - V_{DS}$, V_P is gradually reduced and V-t balance restored.

8.4 Device Functional Modes

The functional modes of the SN6501 are divided into start-up, operating, and off-mode.

8.4.1 Start-Up Mode

When the supply voltage at V_{CC} ramps up to 2.4V typical, the internal oscillator starts operating at a start frequency of 300 kHz. The output stage begins switching but the amplitude of the drain signals at D1 and D2 has not reached its full maximum yet.

8.4.2 Operating Mode

When the device supply has reached its nominal value ±10% the oscillator is fully operating. However variations over supply voltage and operating temperature can vary the switching frequencies at D1 and D2 between 250 kHz and 495 kHz for V_{CC} = 3.3 V ±10%, and between 300 kHz and 620 kHz for V_{CC} = 5 V ±10%.

8.4.3 Off-Mode

The SN6501 is deactivated by reducing V_{CC} to 0 V. In this state both drain outputs, D1 and D2, are high-impedance.

9 Application and Implementation

Note

Information in the following applications sections is not part of the TI component specification, and TI does not warrant its accuracy or completeness. TI's customers are responsible for determining suitability of components for their purposes. Customers should validate and test their design implementation to confirm system functionality.

9.1 Application Information

The SN6501-Q1 is a transformer driver designed for low-cost, small form-factor, isolated DC-DC converters utilizing the push-pull topology. The device includes an oscillator that feeds a gate-drive circuit. The gate-drive, comprising a frequency divider and a break-before-make (BBM) logic, provides two complementary output signals which alternately turn the two output transistors on and off.

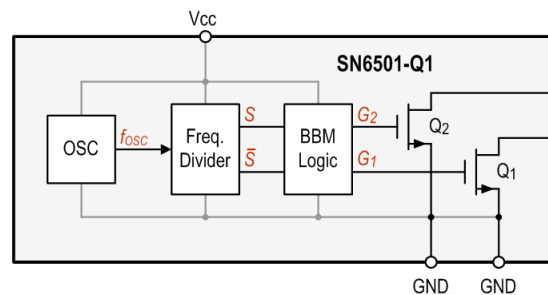

Figure 9-1. SN6501-Q1 Block Diagram

The output frequency of the oscillator is divided down by an asynchronous divider that provides two complementary output signals, S and \bar{S} , with a 50% duty cycle. A subsequent break-before-make logic inserts a dead-time between the high-pulses of the two signals. The resulting output signals, G_1 and G_2 , present the gate-drive signals for the output transistors Q_1 and Q_2 . As shown in Figure 9-2, before either one of the gates can assume logic high, there must be a short time period during which both signals are low and both transistors are high-impedance. This short period, known as break-before-make time, is required to avoid shorting out both ends of the primary.

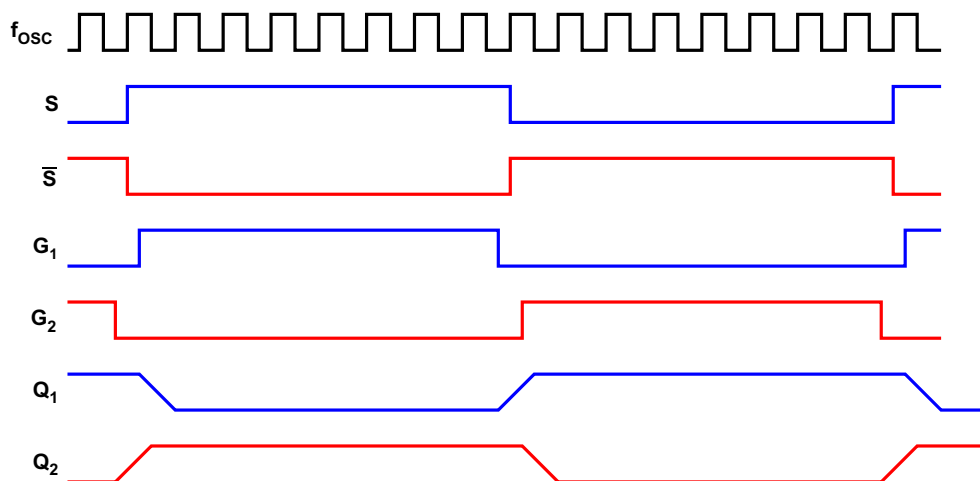

Figure 9-2. Detailed Output Signal Waveforms

9.2 Typical Application

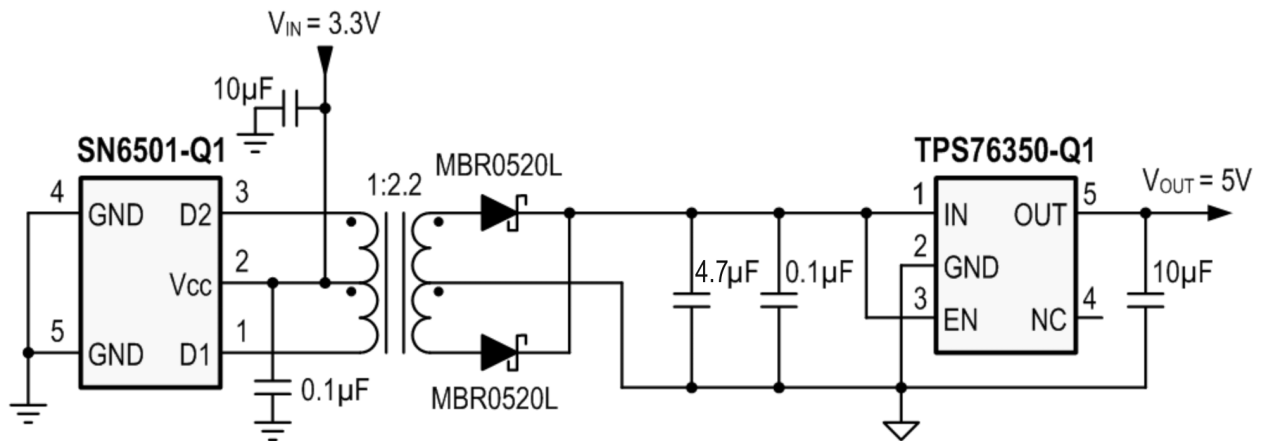

Figure 9-3. Typical Application Schematic (SN6501-Q1)

9.2.1 Design Requirements

For this design example, use the parameters listed in [Table 9-1](#) as design parameters.

Table 9-1. Design Parameters

DESIGN PARAMETER	EXAMPLE VALUE
Input voltage range	3.3 V \pm 3%
Output voltage	5 V
Maximum load current	100 mA

9.2.2 Detailed Design Procedure

The following recommendations on components selection focus on the design of an efficient push-pull converter with high current drive capability. Contrary to popular belief, the output voltage of the unregulated converter output drops significantly over a wide range in load current. The characteristic curve in [Figure 6-11](#) for example shows that the difference between V_{OUT} at minimum load and V_{OUT} at maximum load exceeds a transceiver's supply range. Therefore, in order to provide a stable, load independent supply while maintaining maximum possible efficiency the implementation of a low dropout regulator (LDO) is strongly advised.

The final converter circuit is shown in [Figure 9-7](#). The measured V_{OUT} and efficiency characteristics for the regulated and unregulated outputs are shown in [Figure 6-1](#) to [Figure 6-28](#).

9.2.2.1 SN6501 Drive Capability

The SN6501 transformer driver is designed for low-power push-pull converters with input and output voltages in the range of 3 V to 5.5 V. While converter designs with higher output voltages are possible, care must be taken that higher turns ratios don't lead to primary currents that exceed the SN6501 specified current limits.

Unlike [SN6505](#) devices, SN6501 does not have soft-start, internal current limit, or thermal shutdown (TSD) features. Therefore, unregulated large currents exceeding device absolute maximum current ratings may damage the device or affect its long-term reliability. In addition, high capacitive loads at the isolated power supply output may appear as short circuits to SN6501 during power-up and may exceed the device's maximum current ratings. When using SN6501, it is recommended to incorporate LDOs with low short-circuit current limits or soft-start features to ensure excessive current is not drawn from SN6501.

9.2.2.2 LDO Selection

The minimum requirements for a suitable low dropout regulator are:

- Its current drive capability should slightly exceed the specified load current of the application to prevent the LDO from dropping out of regulation. Therefore for a load current of 100 mA, choose a 100 mA to 150 mA LDO. While regulators with higher drive capabilities are acceptable, they also usually possess higher dropout voltages that will reduce overall converter efficiency.
- The internal dropout voltage, V_{DO} , at the specified load current should be as low as possible to maintain efficiency. For a low-cost 150 mA LDO, a V_{DO} of 150 mV at 100 mA is common. Be aware however, that this lower value is usually specified at room temperature and can increase by a factor of 2 over temperature, which in turn will raise the required minimum input voltage.
- The required minimum input voltage preventing the regulator from dropping out of line regulation is given with:

$$V_{I-min} = V_{DO-max} + V_{O-max} \quad (1)$$

This means in order to determine V_I for worst-case condition, the user must take the maximum values for V_{DO} and V_O specified in the LDO data sheet for rated output current (i.e., 100 mA) and add them together. Also specify that the output voltage of the push-pull rectifier at the specified load current is equal or higher than V_{I-min} . If it is not, the LDO will lose line-regulation and any variations at the input will pass straight through to the output. Hence below V_{I-min} the output voltage will follow the input and the regulator behaves like a simple conductor.

- The maximum regulator input voltage must be higher than the rectifier output under no-load. Under this condition there is no secondary current reflected back to the primary, thus making the voltage drop across R_{DS-on} negligible and allowing the entire converter input voltage to drop across the primary. At this point the secondary reaches its maximum voltage of

$$V_{S-max} = V_{IN-max} \times n \quad (2)$$

with V_{IN-max} as the maximum converter input voltage and n as the transformer turns ratio. Thus to prevent the LDO from damage the maximum regulator input voltage must be higher than V_{S-max} . [Table 9-2](#) lists the maximum secondary voltages for various turns ratios commonly applied in push-pull converters with 100 mA output drive.

Table 9-2. Required Maximum LDO Input Voltages for Various Push-Pull Configurations

PUSH-PULL CONVERTER				LDO
CONFIGURATION	V_{IN-max} [V]	TURNS-RATIO	V_{S-max} [V]	V_{I-max} [V]
3.3 V_{IN} to 3.3 V_{OUT}	3.6	1.5 ± 3%	5.6	6 to 10
3.3 V_{IN} to 5 V_{OUT}	3.6	2.2 ± 3%	8.2	10
5 V_{IN} to 5 V_{OUT}	5.5	1.5 ± 3%	8.5	10

9.2.2.3 Diode Selection

A rectifier diode should always possess low-forward voltage to provide as much voltage to the converter output as possible. When used in high-frequency switching applications, such as the SN6501 however, the diode must also possess a short recovery time. Schottky diodes meet both requirements and are therefore strongly recommended in push-pull converter designs. A good choice for low-volt applications and ambient temperatures of up to 85°C is the low-cost Schottky rectifier MBR0520L with a typical forward voltage of 275 mV at 100-mA forward current. For higher output voltages such as ±10 V and above use the MBR0530 which provides a higher DC blocking voltage of 30 V.

Lab measurements have shown that at temperatures higher than 100°C the leakage currents of the above Schottky diodes increase significantly. This can cause thermal runaway leading to the collapse of the rectifier output voltage. Therefore, for ambient temperatures higher than 85°C use low-leakage Schottky diodes, such as RB168M-40.

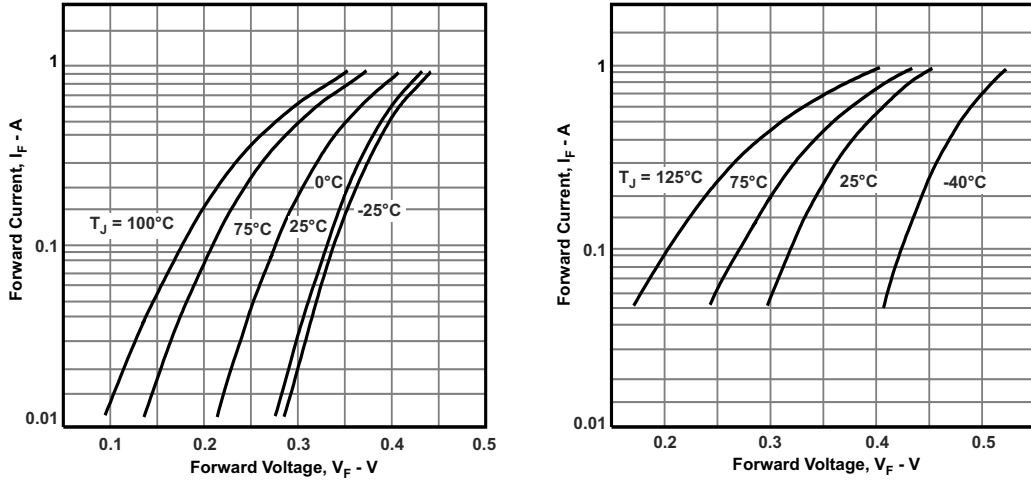

Figure 9-4. Diode Forward Characteristics for MBR0520L (Left) and MBR0530 (Right)

9.2.2.4 Capacitor Selection

The capacitors in the converter circuit in [Figure 9-7](#) are multi-layer ceramic chip (MLCC) capacitors.

As with all high speed CMOS ICs, the SN6501 requires a bypass capacitor in the range of 10 nF to 100 nF.

The input bulk capacitor at the center-tap of the primary supports large currents into the primary during the fast switching transients. For minimum ripple make this capacitor 1 μ F to 10 μ F. In a 2-layer PCB design with a dedicated ground plane, place this capacitor close to the primary center-tap to minimize trace inductance. In a 4-layer board design with low-inductance reference planes for ground and V_{IN} , the capacitor can be placed at the supply entrance of the board. To ensure low-inductance paths use two vias in parallel for each connection to a reference plane or to the primary center-tap.

The bulk capacitor at the rectifier output smoothes the output voltage. Make this capacitor 1 μ F to 10 μ F.

The small capacitor at the regulator input is not necessarily required. However, good analog design practice suggests, using a small value of 47 nF to 100 nF improves the regulator's transient response and noise rejection.

The LDO output capacitor buffers the regulated output for the subsequent isolator and transceiver circuitry. The choice of output capacitor depends on the LDO stability requirements specified in the data sheet. However, in most cases, a low-ESR ceramic capacitor in the range of 4.7 μ F to 10 μ F will satisfy these requirements.

9.2.2.5 Transformer Selection

9.2.2.5.1 V-t Product Calculation

To prevent a transformer from saturation its V-t product must be greater than the maximum V-t product applied by the SN6501. The maximum voltage delivered by the SN6501 is the nominal converter input plus 10%. The maximum time this voltage is applied to the primary is half the period of the lowest frequency at the specified input voltage. Therefore, the transformer's minimum V-t product is determined through:

$$V_{t_{\min}} \geq V_{IN-\max} \times \frac{T_{\max}}{2} = \frac{V_{IN-\max}}{2 \times f_{\min}} \quad (3)$$

Inserting the numeric values from the data sheet into the equation above yields the minimum V-t products of

$$V_{t_{\min}} \geq \frac{3.6 \text{ V}}{2 \times 250 \text{ kHz}} = 7.2 \text{ V}\mu\text{s} \quad \text{for 3.3 V, and}$$

$$V_{t_{\min}} \geq \frac{5.5 \text{ V}}{2 \times 300 \text{ kHz}} = 9.1 \text{ V}\mu\text{s} \quad \text{for 5 V applications.} \quad (4)$$

Common V-t values for low-power center-tapped transformers range from 22 $V\mu\text{s}$ to 150 $V\mu\text{s}$ with typical footprints of 10 mm x 12 mm. However, transformers specifically designed for PCMCIA applications provide as little as 11 $V\mu\text{s}$ and come with a significantly reduced footprint of 6 mm x 6 mm only.

While Vt-wise all of these transformers can be driven by the SN6501, other important factors such as isolation voltage, transformer wattage, and turns ratio must be considered before making the final decision.

9.2.2.5.2 Turns Ratio Estimate

Assume the rectifier diodes and linear regulator has been selected. Also, it has been determined that the transformer chosen must have a V-t product of at least 11 $V\mu\text{s}$. However, before searching the manufacturer websites for a suitable transformer, the user still needs to know its minimum turns ratio that allows the push-pull converter to operate flawlessly over the specified current and temperature range. This minimum transformation ratio is expressed through the ratio of minimum secondary to minimum primary voltage multiplied by a correction factor that takes the transformer's typical efficiency of 97% into account.

$$n_{\min} = 1.031 \times \frac{V_{s-\min}}{V_{p-\min}} \quad (5)$$

V_{S-min} must be large enough to allow for a maximum voltage drop, V_{F-max} , across the rectifier diode and still provide sufficient input voltage for the regulator to remain in regulation. From the LDO SELECTION section, this minimum input voltage is known and by adding V_{F-max} gives the minimum secondary voltage with:

$$V_{S-min} = V_{F-max} + V_{DO-max} + V_{O-max} \quad (6)$$

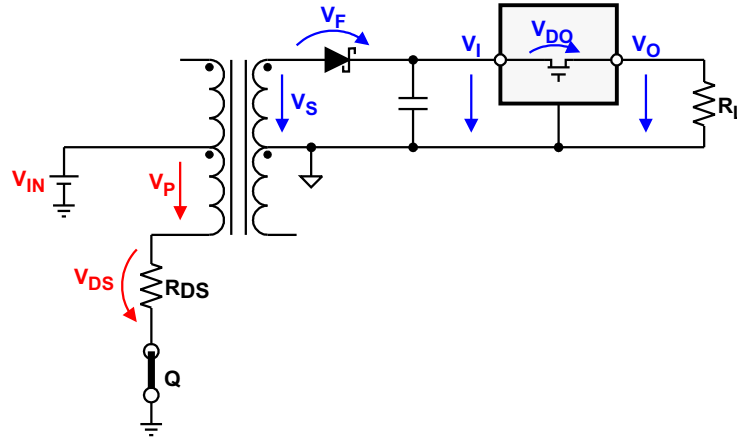

Figure 9-5. Establishing the Required Minimum Turns Ratio Through $n_{min} = 1.031 \times V_{S-min} / V_{P-min}$

Then calculating the available minimum primary voltage, V_{P-min} , involves subtracting the maximum possible drain-source voltage of the SN6501, V_{DS-max} , from the minimum converter input voltage V_{IN-min} :

$$V_{P-min} = V_{IN-min} - V_{DS-max} \quad (7)$$

V_{DS-max} however, is the product of the maximum $R_{DS(on)}$ and I_D values for a given supply specified in the SN6501 data sheet:

$$V_{DS-max} = R_{DS-max} \times I_{D-max} \quad (8)$$

Then inserting Equation 8 into Equation 7 yields:

$$V_{P-min} = V_{IN-min} - R_{DS-max} \times I_{D-max} \quad (9)$$

and inserting Equation 9 and Equation 6 into Equation 5 provides the minimum turns ratio with:

$$n_{min} = 1.031 \times \frac{V_{F-max} + V_{DO-max} + V_{O-max}}{V_{IN-min} - R_{DS-max} \times I_{D-max}} \quad (10)$$

Example:

For a 3.3 V_{IN} to 5 V_{OUT} converter using the rectifier diode MBR0520L and the 5 V LDO TPS76350, the data sheet values taken for a load current of 100 mA and a maximum temperature of 85°C are $V_{F-max} = 0.2$ V, $V_{DO-max} = 0.2$ V, and $V_{O-max} = 5.175$ V.

Then assuming that the converter input voltage is taken from a 3.3 V controller supply with a maximum $\pm 2\%$ accuracy makes $V_{IN-min} = 3.234$ V. Finally the maximum values for drain-source resistance and drain current at 3.3 V are taken from the SN6501 data sheet with $R_{DS-max} = 3$ Ω and $I_{D-max} = 150$ mA.

Inserting the values above into Equation 10 yields a minimum turns ratio of:

$$n_{min} = 1.031 \times \frac{0.2V + 0.2V + 5.175 V}{3.234 V - 3 \Omega \times 150 mA} = 2 \quad (11)$$

Most commercially available transformers for 3-to-5 V push-pull converters offer turns ratios between 2.0 and 2.3 with a common tolerance of $\pm 3\%$.

9.2.2.5.3 Recommended Transformers

Depending on the application, use the minimum configuration in [Figure 9-6](#) or standard configuration in [Figure 9-7](#).

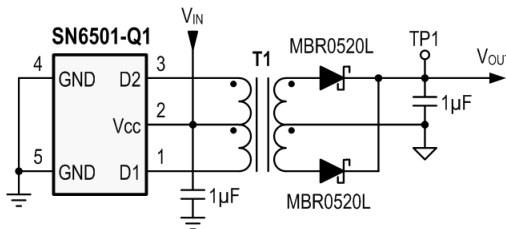

Figure 9-6. Unregulated Output for Low-Current Loads With Wide Supply Range

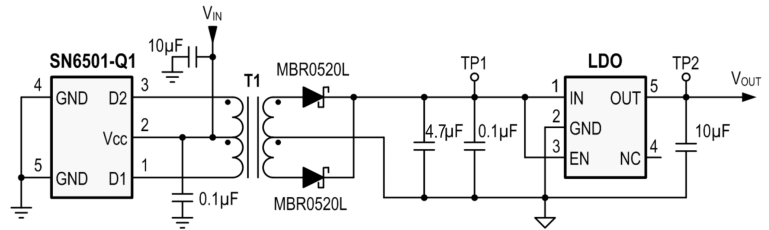

Figure 9-7. Regulated Output for Stable Supplies and High Current Loads

The Würth Electronics Midcom isolation transformers in [Table 9-3](#) are optimized designs for the SN6501, providing high efficiency and small form factor at low-cost.

The 1:1.1 and 1:1.7 turns-ratios are designed for logic applications with wide supply rails and low load currents. These applications operate without LDO, thus achieving further cost-reduction.

Table 9-3. Recommended Isolation Transformers Optimized for SN6501

Turns Ratio	V x T (Vµs)	Isolation (VRMS)	Dimensions (mm)	Application	LDO	Figures	Order No.	Manufacturer
1:1.1 ±2%	7	2500	6.73 x 10.05 x 4.19	3.3 V → 3.3 V	No	Figure 6-1 Figure 6-2	760390011	Würth Electronics/ Midcom
1:1.1 ±2%	5 V → 5 V			Figure 6-3 Figure 6-4		760390012		
1:1.7 ±2%	3.3 V → 5 V			Figure 6-5 Figure 6-6		760390013		
1:1.3 ±2%	11			3.3 V → 3.3 V 5 V → 5 V	Yes	Figure 6-7 Figure 6-8 Figure 6-9 Figure 6-10	760390014	
1:2.1 ±2%	3.3 V → 5 V			Figure 6-11 Figure 6-12		760390015		
1.23:1 ±2%	5 V → 3.3 V			Figure 6-13 Figure 6-14		750313710		
1:1.1 ±2%	11	5000	9.14 x 12.7 x 7.37	3.3 V → 3.3 V	No	Figure 6-15 Figure 6-16	750313734	
1:1.1 ±2%				5 V → 5 V		Figure 6-17 Figure 6-18	750313734	
1:1.7 ±2%				3.3 V → 5 V		Figure 6-19 Figure 6-20	750313769	
1:1.3 ±2%				3.3 V → 3.3 V 5 V → 5 V	Yes	Figure 6-21 Figure 6-22 Figure 6-23 Figure 6-24	750313638	
1:2.1 ±2%				3.3 V → 5 V		Figure 6-25 Figure 6-26	750313626	
1.3:1 ±2%				5 V → 3.3 V		Figure 6-27 Figure 6-28	750313638	

Table 9-3. Recommended Isolation Transformers Optimized for SN6501 (continued)

Turns Ratio	V x T (V μ s)	Isolation (V _{RMS})	Dimensions (mm)	Application	LDO	Figures	Order No.	Manufacturer
1:1.1 \pm 2%	7	1500	7.1 x 11 x 4.19	3.3 V \rightarrow 3.3V	No	N/A	EPC3804G-L	PCA Electronics
1:1.1 \pm 2%	11	2500		5V \rightarrow 5V	No	N/A	EPC3805G-L	
1:1.7 \pm 2%	11			3.3V \rightarrow 5V 3.3V \rightarrow 3.3V	No / Yes	N/A	EPC3806G-L	
1:1.3 \pm 2%	11			3.3V \rightarrow 3.3V 5V \rightarrow 5V	Yes	N/A	EPC3807G-L	
1:2 \pm 2%	11			3.3V \rightarrow 5V	Yes	N/A	EPC3808G-L	
1:1.1 \pm 2%	4.3			8.6 x 12.5 x 5.97	5V \rightarrow 5V	No	N/A	
1:1	11	4200	10.8 x 15.2 x 6.6	3.3V \rightarrow 3.3V 5V \rightarrow 5V	No	N/A	HCTSM80101AAL	Bourns
1:2				3.3V \rightarrow 5V	Yes	N/A	HCTSM80102AAL	
2:1				5V \rightarrow 1.8V	Yes	N/A	HCTSM80201AAL	
3:4				3.3V \rightarrow 3.3V 5V \rightarrow 5V	Yes	N/A	HCTSM80304BAL	
3:5				3.3V \rightarrow 5V	No	N/A	HCTSM80305BAL	
3:8				5V \rightarrow 12V	Yes	N/A	HCTSM80308BAL	
4:3				5V \rightarrow 3.3V	No	N/A	HCTSM80403AAL	
8:3				5V \rightarrow 1.8V	No	N/A	HCTSM80803AAL	
8:9				3.3V \rightarrow 3.3V 5V \rightarrow 5V	No	N/A	HCTSM80809AAL	
9:10				N/A		HCTSM80910BAL		
10:17				3.3V \rightarrow 5V	Yes	N/A	HCTSM81017CAL	

9.2.3 Application Curve

See [Table 9-3](#) for application curves.

9.2.4 Higher Output Voltage Designs

The SN6501 can drive push-pull converters that provide high output voltages of up to 30 V, or bipolar outputs of up to ± 15 V. Using commercially available center-tapped transformers, with their rather low turns ratios of 0.8 to 5, requires different rectifier topologies to achieve high output voltages. [Figure 9-8](#) to [Figure 9-11](#) show some of these topologies together with their respective open-circuit output voltages.

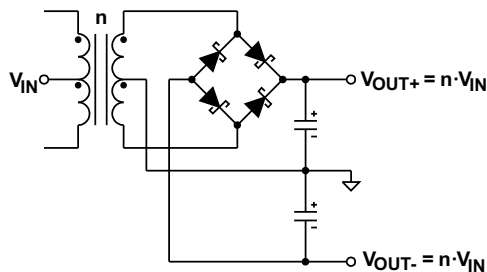

Figure 9-8. Bridge Rectifier With Center-Tapped Secondary Enables Bipolar Outputs

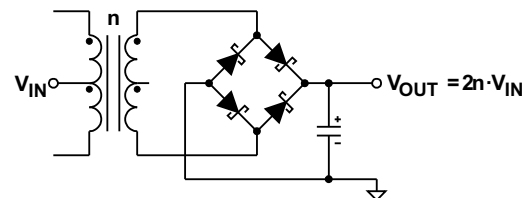

Figure 9-9. Bridge Rectifier Without Center-Tapped Secondary Performs Voltage Doubling

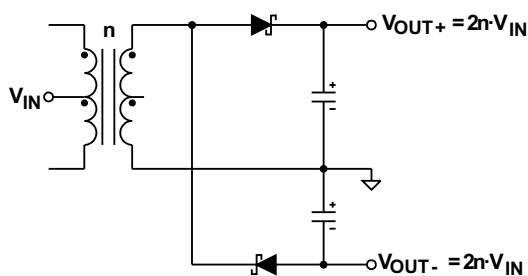

Figure 9-10. Half-Wave Rectifier Without Center-Tapped Secondary Performs Voltage Doubling, Centered Ground Provides Bipolar Outputs

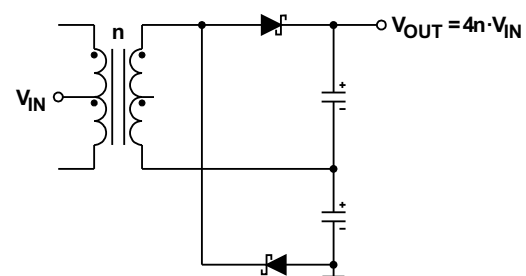

Figure 9-11. Half-Wave Rectifier Without Centered Ground and Center-Tapped Secondary Performs Voltage Doubling Twice, Hence Quadrupling V_{IN}

9.2.5 Application Circuits

The following application circuits are shown for a 3.3 V input supply commonly taken from the local, regulated micro-controller supply. For 5 V input voltages requiring different turn ratios refer to the transformer manufacturers and their websites listed in [Table 9-4](#).

Table 9-4. Transformer Manufacturers

Coilcraft Inc.	http://www.coilcraft.com
Halo-Electronics Inc.	http://www.haloelectronics.com
Murata Power Solutions	http://www.murata-ps.com
Würth Electronics Midcom Inc	http://www.midcom-inc.com

Certain components might not possess AEC-Q100 Q1 qualification. For more detailed information on qualified components for automotive applications please refer to the automotive web page: <http://www.ti.com/lsds/ti/apps/automotive/applications.page>.

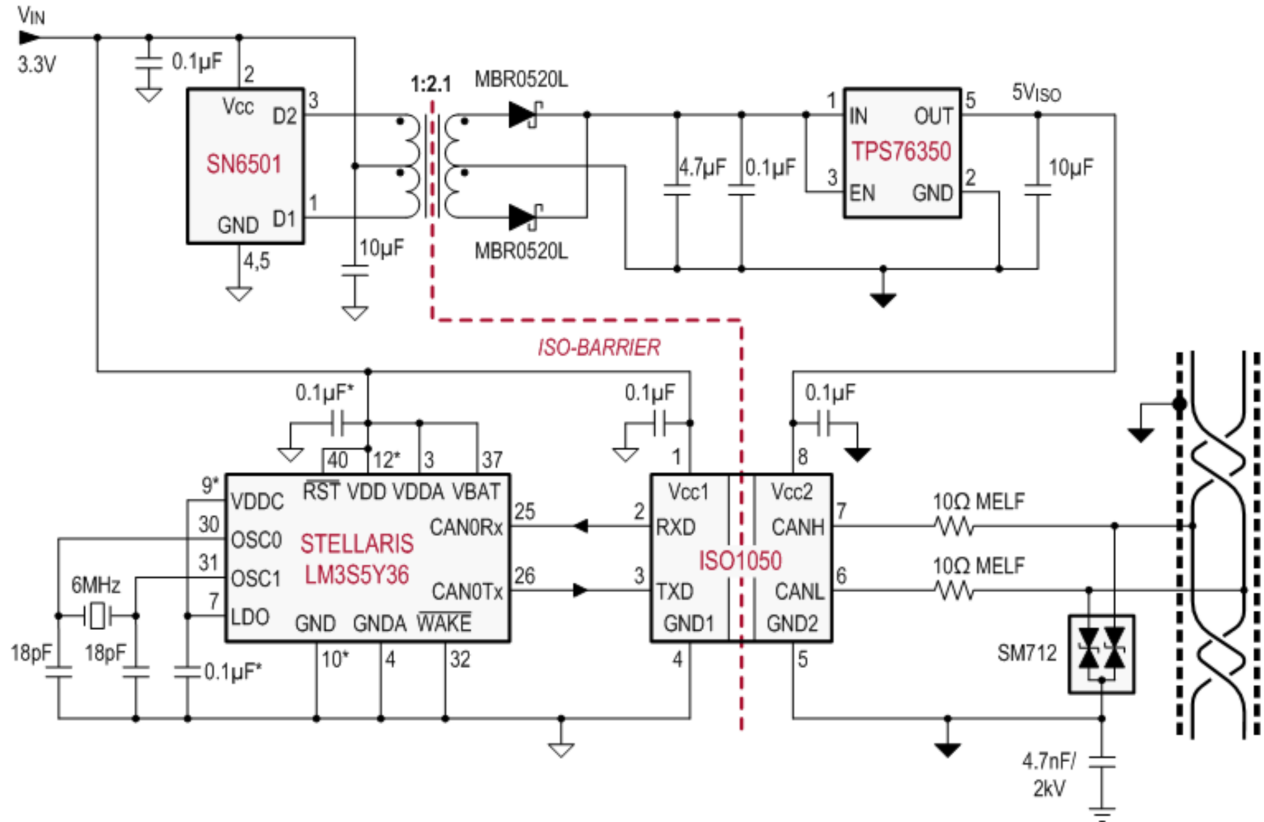

Figure 9-13. Isolated Can Interface

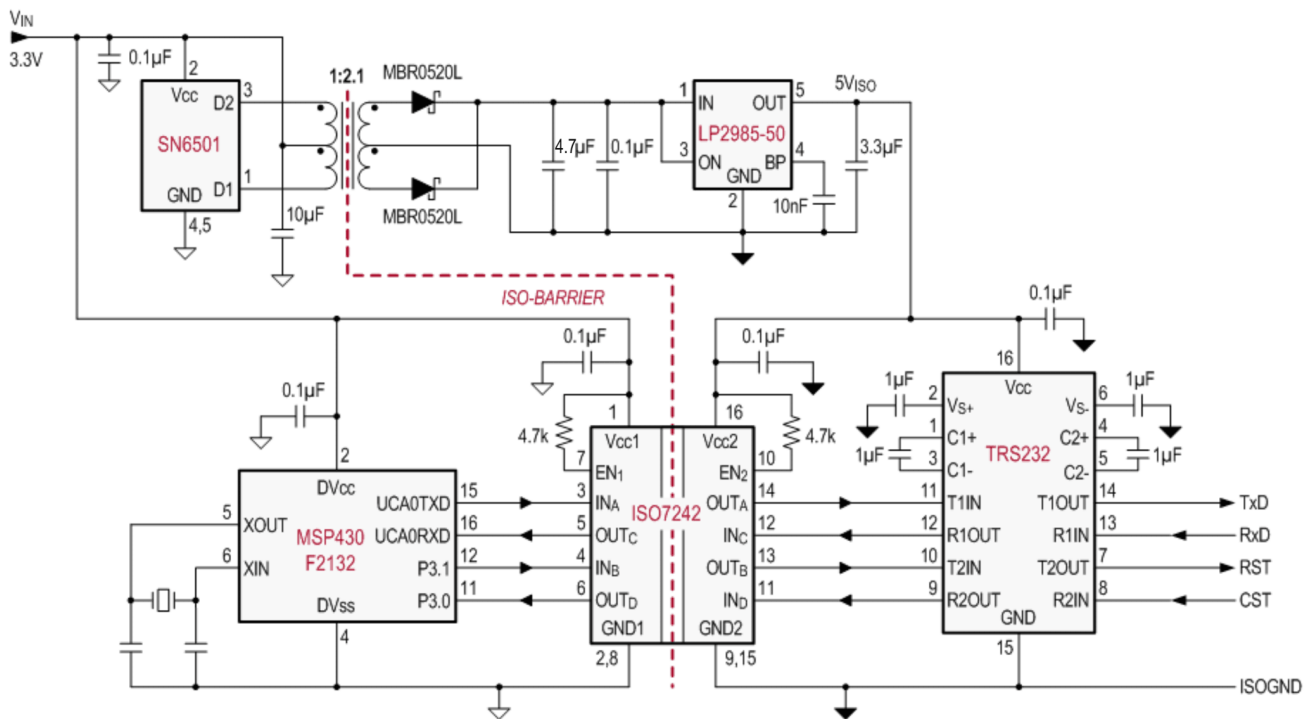

Figure 9-14. Isolated RS-232 Interface

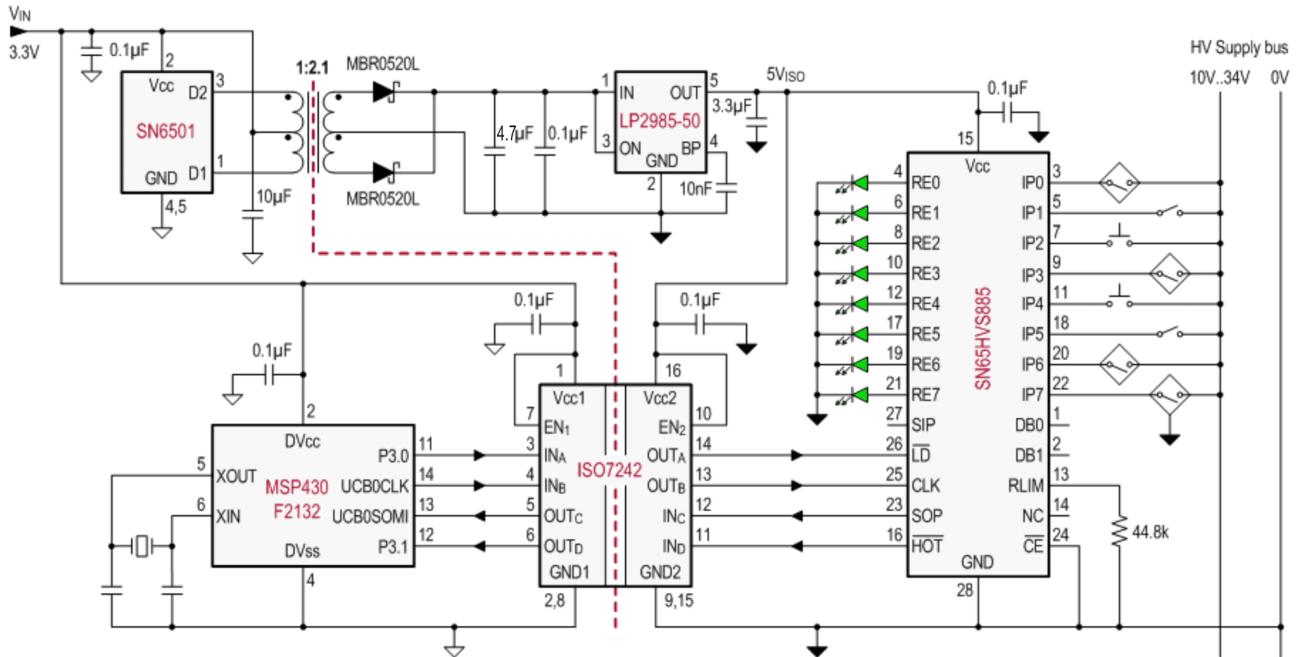

Figure 9-15. Isolated Digital Input Module

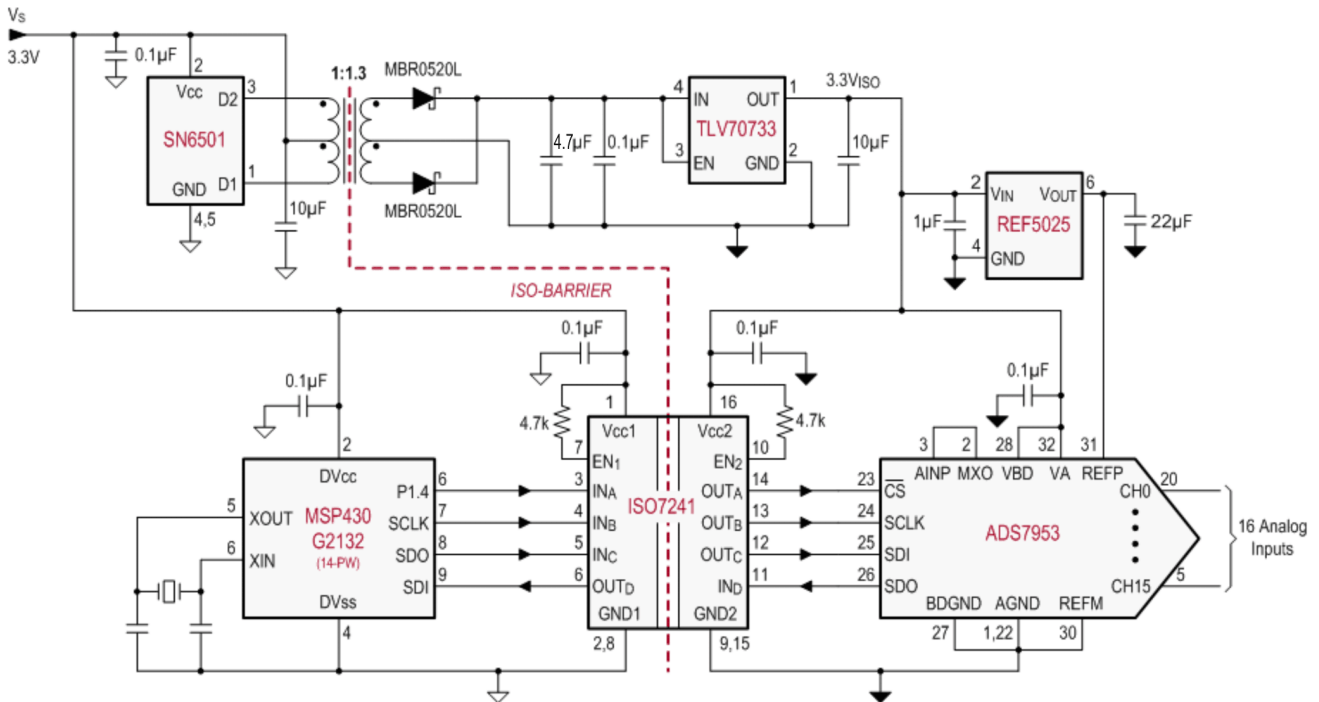

Figure 9-16. Isolated SPI Interface for an Analog Input Module With 16 Inputs

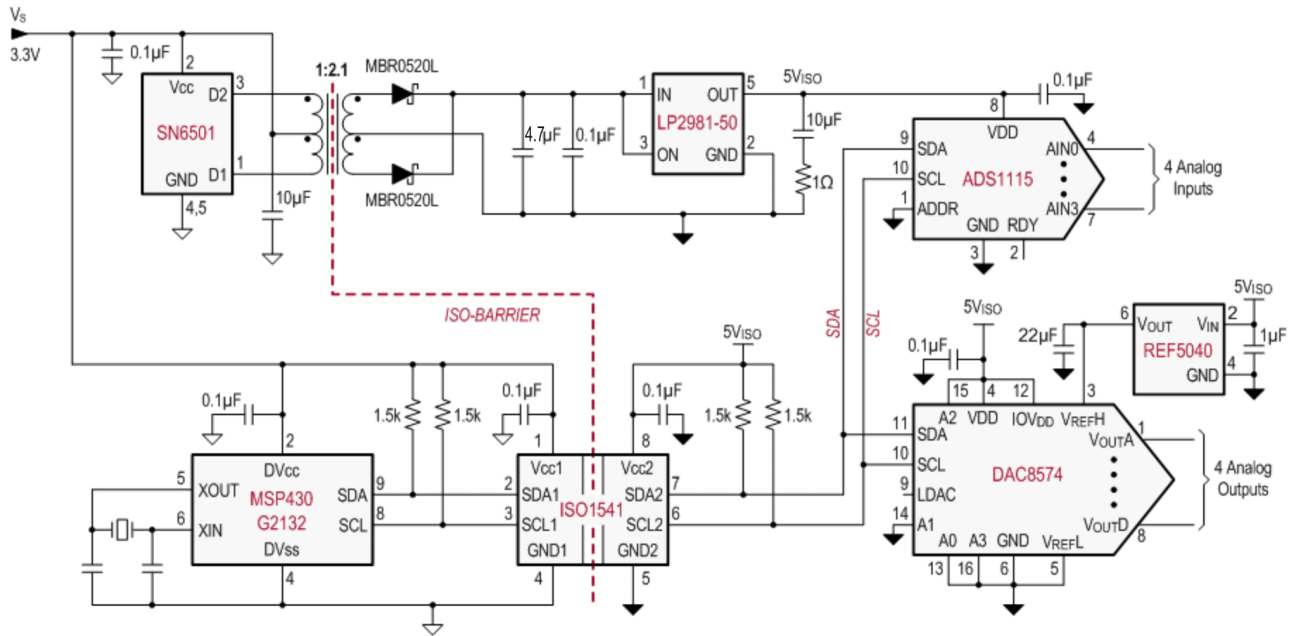

Figure 9-17. Isolated I²C Interface for an Analog Data Acquisition System With 4 Inputs and 4 Outputs

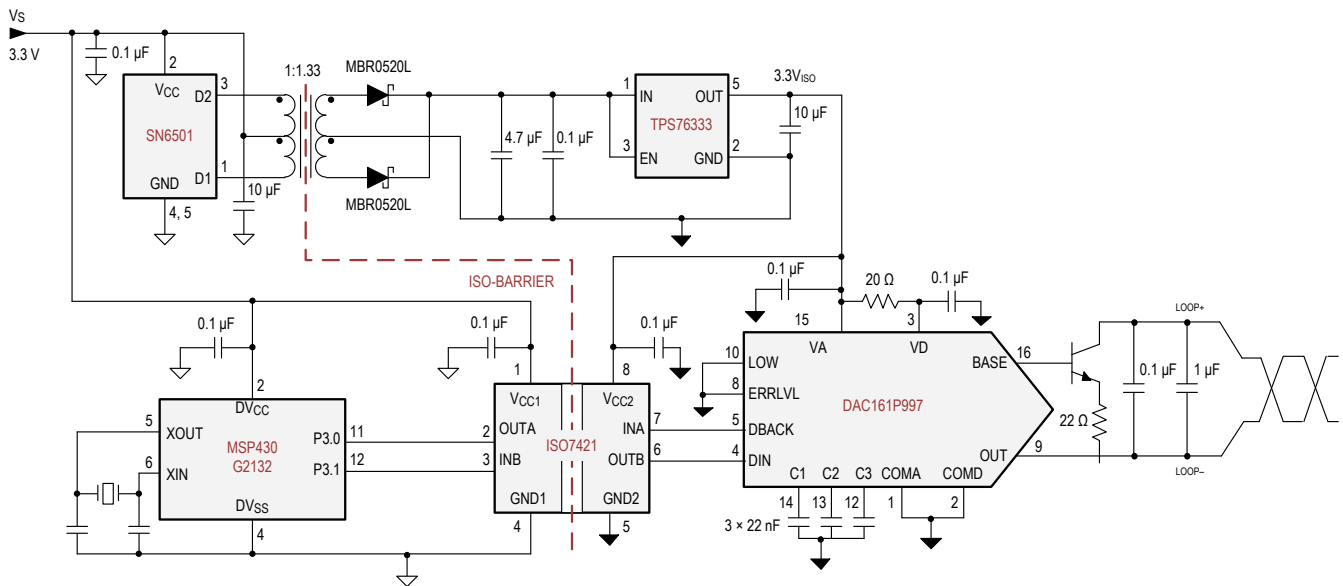

Figure 9-18. Isolated 4-20 mA Current Loop

10 Power Supply Recommendations

10.1

The device is designed to operate from an input voltage supply range between 3.3 V and 5 V nominal. This input supply must be regulated within $\pm 10\%$. If the input supply is located more than a few inches from the SN6501 a 0.1 μF by-pass capacitor should be connected as possible to the device V_{CC} pin, and a 10 μF capacitor should be connected close to the transformer center-tap pin.

11 Layout

11.1 Layout Guidelines

- The V_{IN} pin must be buffered to ground with a low-ESR ceramic bypass-capacitor. The recommended capacitor value can range from 1 μF to 10 μF . The capacitor must have a voltage rating of 10 V minimum and a X5R or X7R dielectric.
- The optimum placement is closest to the V_{IN} and GND pins at the board entrance to minimize the loop area formed by the bypass-capacitor connection, the V_{IN} terminal, and the GND pin. See [Figure 11-1](#) for a PCB layout example.
- The connections between the device D1 and D2 pins and the transformer primary endings, and the connection of the device V_{CC} pin and the transformer center-tap must be as close as possible for minimum trace inductance.
- The connection of the device V_{CC} pin and the transformer center-tap must be buffered to ground with a low-ESR ceramic bypass-capacitor. The recommended capacitor value can range from 1 μF to 10 μF . The capacitor must have a voltage rating of 16 V minimum and a X5R or X7R dielectric.
- The device GND pins must be tied to the PCB ground plane using two vias for minimum inductance.
- The ground connections of the capacitors and the ground plane should use two vias for minimum inductance.
- The rectifier diodes should be Schottky diodes with low forward voltage in the 10 mA to 100 mA current range to maximize efficiency.
- The V_{OUT} pin must be buffered to ISO-Ground with a low-ESR ceramic bypass-capacitor. The recommended capacitor value can range from 1 μF to 10 μF . The capacitor must have a voltage rating of 16 V minimum and a X5R or X7R dielectric.

11.2 Layout Example

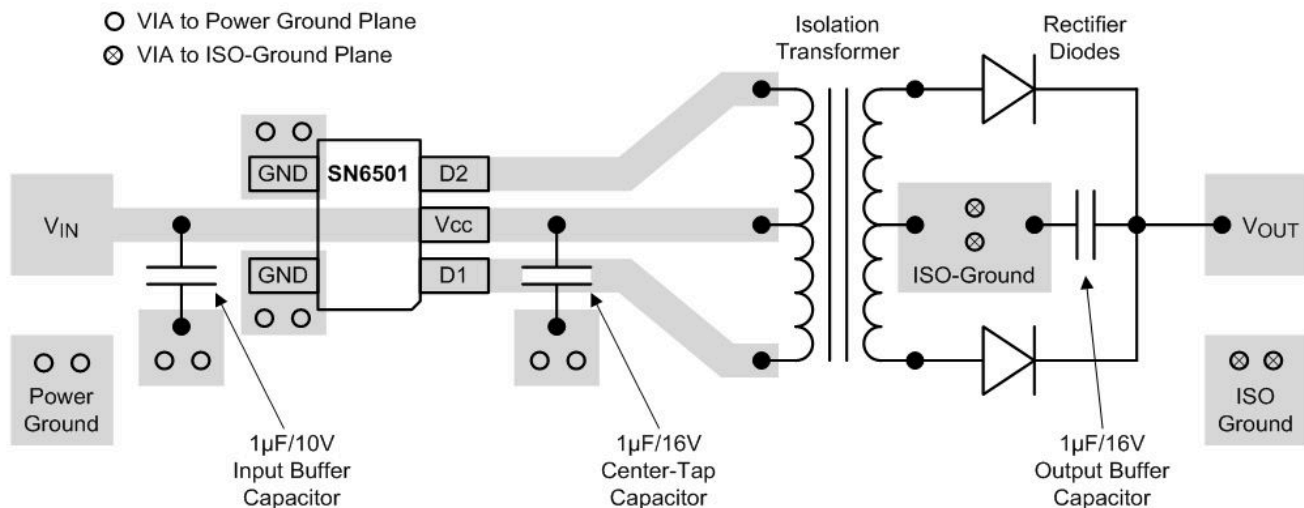

Figure 11-1. Layout Example of a 2-Layer Board (SN6501)

12 Device and Documentation Support

12.1 Device Support

12.1.1 Third-Party Products Disclaimer

TI'S PUBLICATION OF INFORMATION REGARDING THIRD-PARTY PRODUCTS OR SERVICES DOES NOT CONSTITUTE AN ENDORSEMENT REGARDING THE SUITABILITY OF SUCH PRODUCTS OR SERVICES OR A WARRANTY, REPRESENTATION OR ENDORSEMENT OF SUCH PRODUCTS OR SERVICES, EITHER ALONE OR IN COMBINATION WITH ANY TI PRODUCT OR SERVICE.

12.2 Trademarks

All trademarks are the property of their respective owners.

12.3 Electrostatic Discharge Caution



This integrated circuit can be damaged by ESD. Texas Instruments recommends that all integrated circuits be handled with appropriate precautions. Failure to observe proper handling and installation procedures can cause damage.

ESD damage can range from subtle performance degradation to complete device failure. Precision integrated circuits may be more susceptible to damage because very small parametric changes could cause the device not to meet its published specifications.

12.4 Glossary

[TI Glossary](#) This glossary lists and explains terms, acronyms, and definitions.

13 Mechanical, Packaging, and Orderable Information

The following pages include mechanical, packaging, and orderable information. This information is the most current data available for the designated devices. This data is subject to change without notice and revision of this document. For browser-based versions of this data sheet, refer to the left-hand navigation.

PACKAGING INFORMATION

Orderable Device	Status (1)	Package Type	Package Drawing	Pins	Package Qty	Eco Plan (2)	Lead finish/ Ball material (6)	MSL Peak Temp (3)	Op Temp (°C)	Device Marking (4/5)	Samples
SN6501QDBVRQ1	ACTIVE	SOT-23	DBV	5	3000	RoHS & Green	NIPDAU	Level-1-260C-UNLIM	-40 to 125	SBRQ	Samples

(1) The marketing status values are defined as follows:

ACTIVE: Product device recommended for new designs.

LIFEBUY: TI has announced that the device will be discontinued, and a lifetime-buy period is in effect.

NRND: Not recommended for new designs. Device is in production to support existing customers, but TI does not recommend using this part in a new design.

PREVIEW: Device has been announced but is not in production. Samples may or may not be available.

OBSOLETE: TI has discontinued the production of the device.

(2) **RoHS:** TI defines "RoHS" to mean semiconductor products that are compliant with the current EU RoHS requirements for all 10 RoHS substances, including the requirement that RoHS substance do not exceed 0.1% by weight in homogeneous materials. Where designed to be soldered at high temperatures, "RoHS" products are suitable for use in specified lead-free processes. TI may reference these types of products as "Pb-Free".

RoHS Exempt: TI defines "RoHS Exempt" to mean products that contain lead but are compliant with EU RoHS pursuant to a specific EU RoHS exemption.

Green: TI defines "Green" to mean the content of Chlorine (Cl) and Bromine (Br) based flame retardants meet JS709B low halogen requirements of <=1000ppm threshold. Antimony trioxide based flame retardants must also meet the <=1000ppm threshold requirement.

(3) MSL, Peak Temp. - The Moisture Sensitivity Level rating according to the JEDEC industry standard classifications, and peak solder temperature.

(4) There may be additional marking, which relates to the logo, the lot trace code information, or the environmental category on the device.

(5) Multiple Device Markings will be inside parentheses. Only one Device Marking contained in parentheses and separated by a "-" will appear on a device. If a line is indented then it is a continuation of the previous line and the two combined represent the entire Device Marking for that device.

(6) Lead finish/Ball material - Orderable Devices may have multiple material finish options. Finish options are separated by a vertical ruled line. Lead finish/Ball material values may wrap to two lines if the finish value exceeds the maximum column width.

Important Information and Disclaimer: The information provided on this page represents TI's knowledge and belief as of the date that it is provided. TI bases its knowledge and belief on information provided by third parties, and makes no representation or warranty as to the accuracy of such information. Efforts are underway to better integrate information from third parties. TI has taken and continues to take reasonable steps to provide representative and accurate information but may not have conducted destructive testing or chemical analysis on incoming materials and chemicals. TI and TI suppliers consider certain information to be proprietary, and thus CAS numbers and other limited information may not be available for release.

In no event shall TI's liability arising out of such information exceed the total purchase price of the TI part(s) at issue in this document sold by TI to Customer on an annual basis.

OTHER QUALIFIED VERSIONS OF SN6501-Q1 :

- Catalog: [SN6501](#)

NOTE: Qualified Version Definitions:

- Catalog - TI's standard catalog product

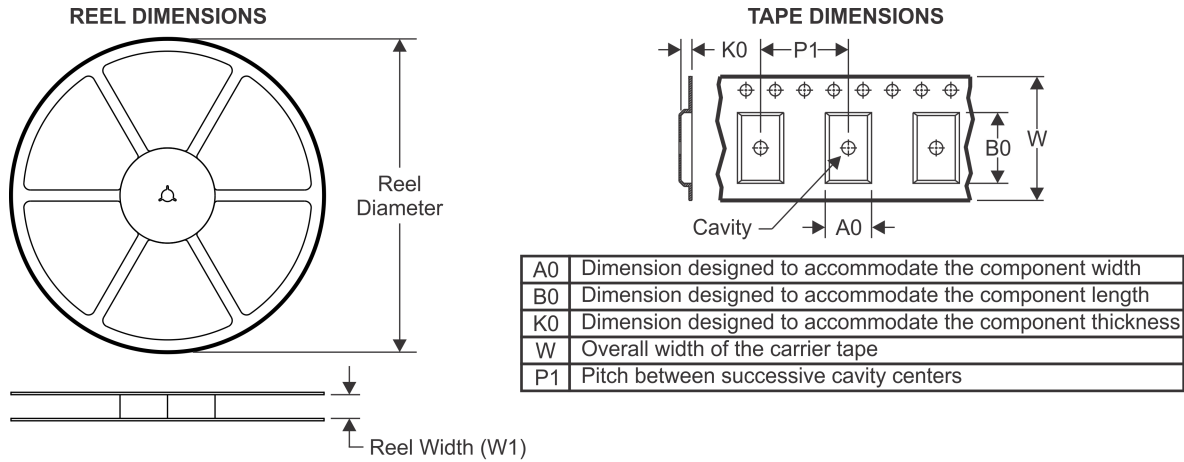
TAPE AND REEL INFORMATION

QUADRANT ASSIGNMENTS FOR PIN 1 ORIENTATION IN TAPE

*All dimensions are nominal

Device	Package Type	Package Drawing	Pins	SPQ	Reel Diameter (mm)	Reel Width W1 (mm)	A0 (mm)	B0 (mm)	K0 (mm)	P1 (mm)	W (mm)	Pin1 Quadrant
SN6501QDBVRQ1	SOT-23	DBV	5	3000	178.0	9.0	3.23	3.17	1.37	4.0	8.0	Q3

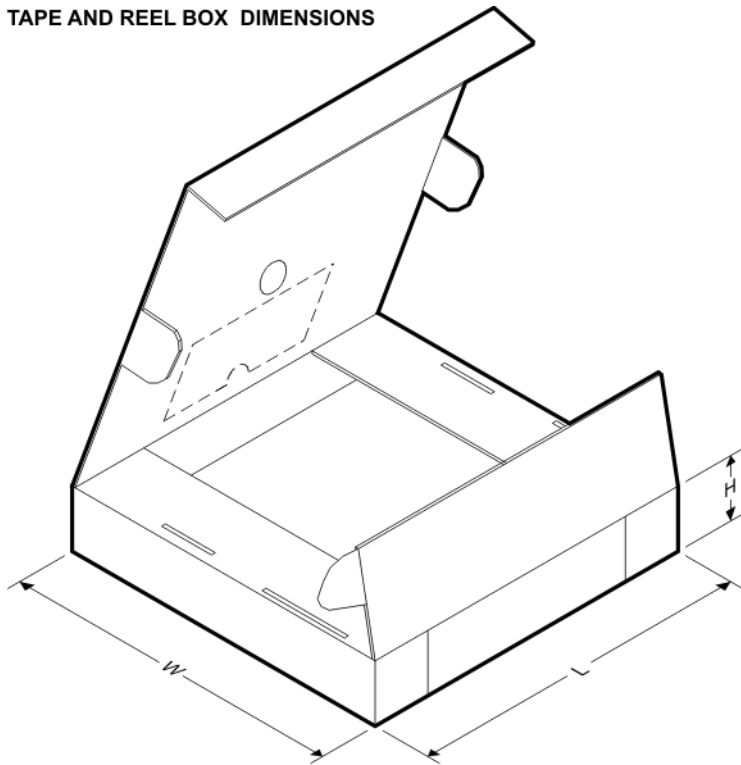
TAPE AND REEL BOX DIMENSIONS



*All dimensions are nominal

Device	Package Type	Package Drawing	Pins	SPQ	Length (mm)	Width (mm)	Height (mm)
SN6501QDBVRQ1	SOT-23	DBV	5	3000	180.0	180.0	18.0

EXAMPLE BOARD LAYOUT

DBV0005A

SOT-23 - 1.45 mm max height

SMALL OUTLINE TRANSISTOR

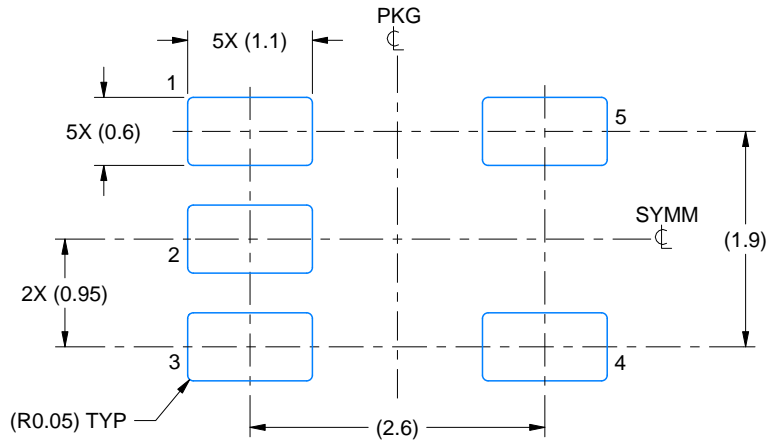

LAND PATTERN EXAMPLE
EXPOSED METAL SHOWN
SCALE:15X

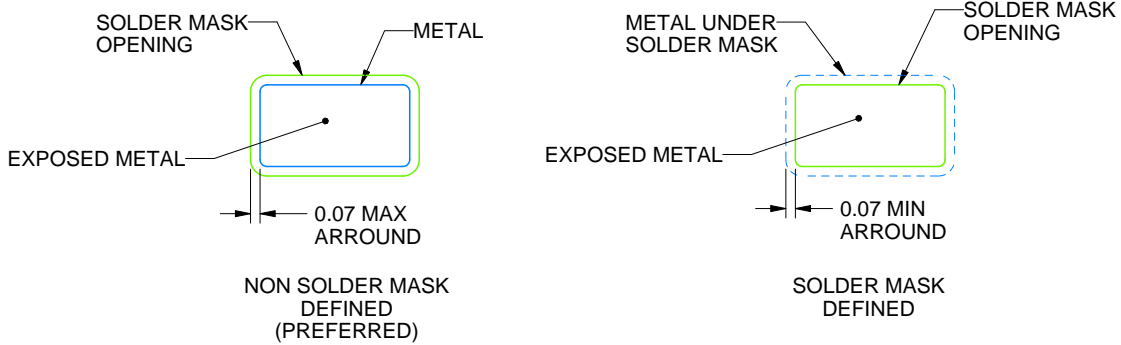

SOLDER MASK DETAILS

4214839/F 06/2021

NOTES: (continued)

- 5. Publication IPC-7351 may have alternate designs.
- 6. Solder mask tolerances between and around signal pads can vary based on board fabrication site.

EXAMPLE STENCIL DESIGN

DBV0005A

SOT-23 - 1.45 mm max height

SMALL OUTLINE TRANSISTOR

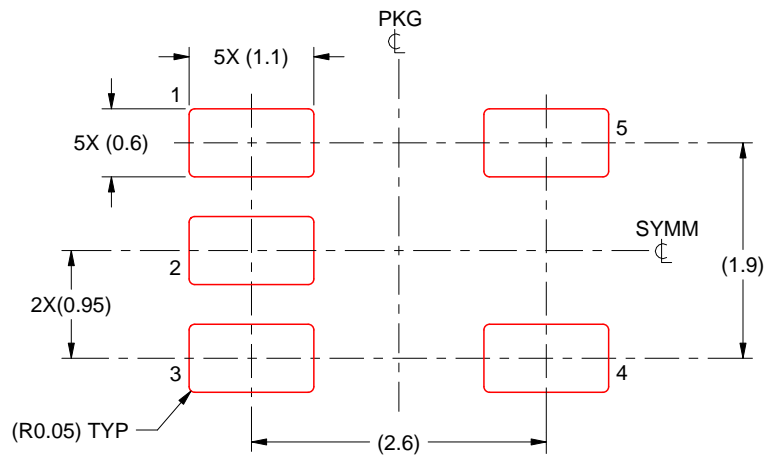

SOLDER PASTE EXAMPLE
BASED ON 0.125 mm THICK STENCIL
SCALE:15X

4214839/F 06/2021

NOTES: (continued)

7. Laser cutting apertures with trapezoidal walls and rounded corners may offer better paste release. IPC-7525 may have alternate design recommendations.
8. Board assembly site may have different recommendations for stencil design.

IMPORTANT NOTICE AND DISCLAIMER

TI PROVIDES TECHNICAL AND RELIABILITY DATA (INCLUDING DATASHEETS), DESIGN RESOURCES (INCLUDING REFERENCE DESIGNS), APPLICATION OR OTHER DESIGN ADVICE, WEB TOOLS, SAFETY INFORMATION, AND OTHER RESOURCES "AS IS" AND WITH ALL FAULTS, AND DISCLAIMS ALL WARRANTIES, EXPRESS AND IMPLIED, INCLUDING WITHOUT LIMITATION ANY IMPLIED WARRANTIES OF MERCHANTABILITY, FITNESS FOR A PARTICULAR PURPOSE OR NON-INFRINGEMENT OF THIRD PARTY INTELLECTUAL PROPERTY RIGHTS.

These resources are intended for skilled developers designing with TI products. You are solely responsible for (1) selecting the appropriate TI products for your application, (2) designing, validating and testing your application, and (3) ensuring your application meets applicable standards, and any other safety, security, or other requirements. These resources are subject to change without notice. TI grants you permission to use these resources only for development of an application that uses the TI products described in the resource. Other reproduction and display of these resources is prohibited. No license is granted to any other TI intellectual property right or to any third party intellectual property right. TI disclaims responsibility for, and you will fully indemnify TI and its representatives against, any claims, damages, costs, losses, and liabilities arising out of your use of these resources.

TI's products are provided subject to TI's Terms of Sale (<https://www.ti.com/legal/termsofsale.html>) or other applicable terms available either on [ti.com](https://www.ti.com) or provided in conjunction with such TI products. TI's provision of these resources does not expand or otherwise alter TI's applicable warranties or warranty disclaimers for TI products.

Mailing Address: Texas Instruments, Post Office Box 655303, Dallas, Texas 75265
Copyright © 2021, Texas Instruments Incorporated