

TUSB1210-Q1 独立 USB 收发器硅芯片

1 特性

- 具有符合 AEC-Q100 标准的以下结果：
 - 温度等级 3: -40°C 至 85°C
 - 人体模型 (HBM) 静电放电 (ESD) 分类等级 1C
 - 充电器件模型 (CDM) ESD 分类等级 C4B
- USB2.0 物理层 (PHY) 收发器芯片，可通过 ULPI 12 引脚接口连接 USB 控制器，其完全符合：
 - 通用串行总线规范 2.0 版
 - USB 2.0 规范移动附录 1.3 版
 - UTMI+ 低引脚接口 (ULPI) 规范 1.1 版
- DP/DM 线路外部组件补偿（专利号 US7965100 B1）
- 连接主机、外设和 OTG 器件内核的接口；针对便携式器件或具有内置 USB OTG 器件内核的系统 ASIC 进行了优化
- 完整的 USB OTG 物理前端支持主机协商协议 (HNP) 与会话请求协议 (SRP)
- ULPI 接口：
 - I/O 接口 (1.8V) 针对无端接 50 Ω 线路阻抗进行了优化
 - ULPI 时钟引脚 (60 MHz) 可同时支持输入和输出时钟配置
 - 符合 ULPI 标准的完全可编程寄存器集
- 采用 32 引脚四方扁平无引线 [QFN (RHB)] 封装

2 应用范围

- 移动电话
- 平板电脑设备
- 台式机
- 便携式计算机
- 视频游戏控制台
- 便携式音乐播放器

3 说明

TUSB1210-Q1 是一款 USB2.0 收发器芯片，可通过 ULPI 接口连接 USB 控制器。支持所有 USB2.0 数据速率（高速 480Mbps、全速 12Mbps 以及低速 1.5Mbps），且兼容主机和外设模式。此外，该器件还支持 UART 模式及原有 ULPI 串行模式。

TUSB1210-Q1 还支持 USB2.0 规范相关的 OTG（1.3 版）可选附件，包括主机协商协议 (HNP) 和会话请求协议 (SRP)。

发送器中的 DP/DM 外部组件补偿可对串联阻抗中的变化进行补偿，以匹配数据线路阻抗和接收器输入端阻抗，限制数据反射，从而改善眼图。

器件信息(1)

部件号	封装	封装尺寸 (标称值)
TUSB1210-Q1	超薄四方扁平无引线 (VQFN) (32)	5.00mm x 5.00mm

(1) 要了解所有可用封装，请见数据表末尾的可订购产品附录。

图

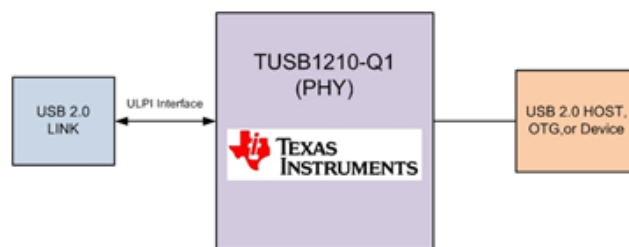

目录

1	特性	1	7.4	Device Functional Modes	18
2	应用范围	1	7.5	Register Map	20
3	说明	1	8	Application and Implementation	49
4	修订历史记录	2	8.1	Application Information	49
5	Pin Configuration and Functions	3	8.2	Typical Application	49
6	Specifications	4	8.3	External Components	53
6.1	Absolute Maximum Ratings	4	9	Power Supply Recommendations	54
6.2	Handling Ratings	4	9.1	TUSB1210 Power Supply	54
6.3	Recommended Operating Conditions	5	9.2	Ground	54
6.4	Thermal Information	5	9.3	Power Providers	54
6.5	Analog I/O Electrical Characteristics	5	9.4	Power Modules	54
6.6	Digital I/O Electrical Characteristics	5	9.5	Power Consumption	55
6.7	Digital IO Pins (Non-ULPI)	5	10	Layout	56
6.8	PHY Electrical Characteristics	6	10.1	Layout Guidelines	56
6.9	Pullup/Pulldown Resistors	8	10.2	Layout Example	56
6.10	OTG Electrical Characteristics	9	11	器件和文档支持	57
6.11	Power Characteristics	10	11.1	文档支持	57
6.12	Switching Characteristics	10	11.2	社区资源	57
6.13	Timing Requirements	11	11.3	商标	57
6.14	Typical Characteristics	13	11.4	静电放电警告	57
7	Detailed Description	14	11.5	术语表	57
7.1	Overview	14	12	机械封装和可订购信息	58
7.2	Functional Block Diagram	14	12.1	Via Channel	58
7.3	Feature Description	15	12.2	封装信息	58

4 修订历史记录

Changes from Original (September 2014) to Revision A

Page

• 已更改特性列表	1
• 删除了说明部分“TUSB1210-Q1 还支持 OTG (1.3 版) ..”之后的 5 个段落	1
• 已更改 图图	1
• Added V_{IL} and V_{IH} to the Recommended Operating Conditions table	5
• Changed the Thermal Information table	5
• Changed the Digital I/O Electrical Characteristics table	5
• Digital IO Electrical Characteristics sections to the Switching Characteristics	10
• Added the Typical Characteristics section	13
• Added 5 new paragraphs to the Overview section	14

5 Pin Configuration and Functions

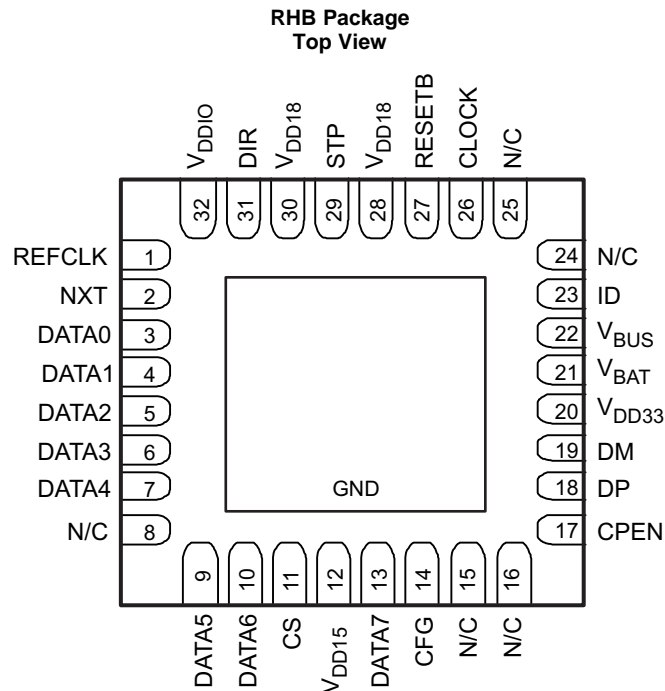

Pin Functions

PIN NAME	NO.	A/D	TYPE	LEVEL	DESCRIPTION
CFG	14	D	I	V _{DDIO}	REFCLK clock frequency configuration pin. Two frequencies are supported: 19.2 MHz when 0, or 26 MHz when 1.
CLOCK	26	D	O	V _{DDIO}	ULPI 60 MHz clock on which ULPI data is synchronized. Two modes are possible: Input Mode: CLOCK defaults as an input. Output Mode: When an input clock is detected on REFCLK pin (after 4 rising edges) then CLOCK will change to an output.
CPEN	17	D	O	V _{DD33}	CMOS active-high digital output control of external 5V VBUS supply
CS	11	D	I	V _{DDIO}	Active-high chip select pin. When low the IC is in power down and ULPI bus is tri-stated. When high normal operation. Tie to V _{DDIO} if unused.
DATA0	3	D	I/O	V _{DDIO}	ULPI DATA input/output signal 0 synchronized to CLOCK
DATA1	4	D	I/O	V _{DDIO}	ULPI DATA input/output signal 1 synchronized to CLOCK
DATA2	5	D	I/O	V _{DDIO}	ULPI DATA input/output signal 2 synchronized to CLOCK
DATA3	6	D	I/O	V _{DDIO}	ULPI DATA input/output signal 3 synchronized to CLOCK
DATA4	7	D	I/O	V _{DDIO}	ULPI DATA input/output signal 4 synchronized to CLOCK
DATA5	9	D	I/O	V _{DDIO}	ULPI DATA input/output signal 5 synchronized to CLOCK
DATA6	10	D	I/O	V _{DDIO}	ULPI DATA input/output signal 6 synchronized to CLOCK
DATA7	13	D	I/O	V _{DDIO}	ULPI DATA input/output signal 7 synchronized to CLOCK
DIR	31	D	O	V _{DDIO}	ULPI DIR output signal
DM	19	A	I/O	V _{DD33}	DM pin of the USB connector
DP	18	A	I/O	V _{DD33}	DP pin of the USB connector
ID	23	A	I/O	V _{DD33}	Identification (ID) pin of the USB connector
N/C	8	–	–	V _{DDIO}	No connect
N/C	15,16, 24, 24	–	–	–	No connect
NXT	2	D	O	V _{DDIO}	ULPI NXT output signal

Pin Functions (continued)

PIN NAME	NO.	A/D	TYPE	LEVEL	DESCRIPTION
REFCLK	1	A	I	3.3 V	V _{DD33} Reference clock input (square-wave only). Tie to GND when pin 26 (CLOCK) is required to be Input mode. Connect to square-wave reference clock of amplitude in the range of 3 V to 3.6 V when Pin 26 (CLOCK) is required to be Output mode. See pin 14 (CFG) description for REFCLK input frequency settings.
RESETB	27	D	I	V _{DDIO}	When low, all digital logic (except 32 kHz logic required for power up sequencing) including registers are reset to their default values, and ULPI bus is tri-stated. When high, normal USB operation.
STP	29	D	I	V _{DDIO}	ULPI STP input signal
V _{BAT}	21	A	power	V _{BAT}	Input supply voltage or battery source
V _{BUS}	22	A	power	V _{BUS}	V _{BUS} pin of the USB connector
VDD15	12	A	power		1.5-V internal LDO output. Connect to external filtering capacitor.
V _{DD18}	28, 30	A	power	V _{DD18}	External 1.8-V supply input. Connect to external filtering capacitor.
V _{DD33}	20	A	power	V _{DD33}	3.3-V internal LDO output. Connect to external filtering capacitor.
V _{DDIO}	32	A	I	V _{DDIO}	External 1.8V supply input for digital I/Os. Connect to external filtering capacitor.
GND	Thermal Pad	A	power	--	Reference Ground

6 Specifications

6.1 Absolute Maximum Ratings

 over operating free-air temperature range (unless otherwise noted)⁽¹⁾

		MIN	MAX	UNIT
V _{CC}	Main battery supply voltage ⁽²⁾	0	5	V
	Voltage on any input ⁽³⁾	-0.3	1 × V _{CC} + 0.3	V
	V _{BUS} input	-2	20	V
	ID, DP, DM inputs	Stress condition specified 24h		V
V _{DDIO}	IO supply voltage	-0.3	1.98	V
T _A	Ambient temperature range	-40	85	°C
T _J	Junction temperature range	-40	150	°C
	Ambient temperature for parametric compliance	Parametric compliance		°C
		With max 125°C as junction temperature		°C
	DP, DM, ID high voltage short circuit	0	5.25	V
		DP, DM or ID pins short circuited to V _{BUS} supply, in any mode of TUSB1210-Q1 operation, continuously for 24 hours		

- Stresses beyond those listed under Absolute Maximum Ratings may cause permanent damage to the device. These are stress ratings only, and functional operation of the device at these or any other conditions beyond those indicated under *Recommended Operating Conditions* is not implied. Exposure to absolute-maximum-rated conditions for extended periods may affect device reliability.
- The product will have negligible reliability impact if voltage spikes of 5.5 V occur for a total (cumulative over lifetime) duration of 5 milliseconds.
- Except V_{BAT} input, V_{BUS}, ID, DP, and DM pads

6.2 Handling Ratings

		MIN	MAX	UNIT		
T _{stg}	Storage temperature range	-65	150	°C		
V _{ESD}	Electrostatic discharge (ESD) performance:	Human body model (HBM), per AEC Q100-002 Classification Level H1C, all pins ⁽¹⁾		V		
		Charged device model (CDM), per AEC Q100-011 Classification Level C4B	Corner pins		-750	750
			Other pins		-500	500

- AEC Q100-002 indicates HBM stressing is done in accordance with ANSI/ESDA/JEDEC JS-001 specifications.

6.3 Recommended Operating Conditions

over operating free-air temperature range (unless otherwise noted)

PARAMETER		TEST CONDITIONS	MIN	NOM	MAX	UNIT
V _{BAT}	Battery supply voltage		2.7	3.6	4.8	V
	Battery supply voltage for USB 2.0 compliancy (USB 2.0 certification)	When V _{DD33} is supplied internally When V _{DD33} is shorted to V _{BAT} externally	3.15 3.05			V
V _{DDIO}	Digital IO pin supply		1.71		1.98	V
V _{IL}	Low-level input voltage	CLOCK, STP, DIR, NXT, DATA0 to DATA7			0.35 x V _{DDIO}	V
V _{IH}	High-level output voltage	CLOCK, STP, DIR, NXT, DATA0 to DATA7	0.65 x V _{DDIO}			V
T _A	Ambient temperature range		–40		85	°C

6.4 Thermal Information

THERMAL METRIC ⁽¹⁾		RHB (16 Pins)	UNIT
R _{θJA}	Junction-to-ambient thermal resistance	34.72	°C/W
R _{θJC(top)}	Junction-to-case(top) thermal resistance	37.3	
R _{θJB}	Junction-to-board thermal resistance	10.3	
ψ _{JT}	Junction-to-top characterization parameter	0.5	
ψ _{JB}	Junction-to-board characterization parameter	10.5	
R _{θJC(bottom)}	Junction-to-case(bottom) thermal resistance	3.6	

(1) For more information about traditional and new thermal metrics, see the *IC Package Thermal Metrics* application report, [SPRA953](#).

6.5 Analog I/O Electrical Characteristics

over operating free-air temperature range (unless otherwise noted)

PARAMETER		CONDITIONS	MIN	TYP	MAX	UNIT
CPEN Output Pin						
V _{OL}	CPEN low-level output voltage	I _{OL} = 3 mA			0.3	V
V _{OH}	CPEN high-level output voltage	I _{OH} = –3 mA	V _{DD33} – 0.3			V

6.6 Digital I/O Electrical Characteristics

over operating free-air temperature range (unless otherwise noted)

PARAMETER		TEST CONDITIONS	MIN	TYP	MAX	UNIT
CLOCK						
V _{OL}	Low-level output voltage	Frequency = 60 MHz, Load = 10 pF			0.45	V
V _{OH}	High-level output voltage		V _{DDIO} – 0.45			V
STP, DIR, NXT, DATA0 to DATA7						
V _{OL}	Low-level output voltage	Frequency = 30 MHz, Load = 10 pF			0.45	
V _{OH}	High-level output voltage		V _{DDIO} – 0.45			

6.7 Digital IO Pins (Non-ULPI)

over operating free-air temperature range (unless otherwise noted)

PARAMETER		TEST CONDITIONS	MIN	TYP	MAX	UNIT
CS, CFG, RESETB Input Pins						
V _{IL}	Maximum low-level input voltage				0.35 x V _{DDIO}	V
V _{IH}	Minimum high-level input voltage		0.65 x V _{DDIO}			V
RESETB Input Pin Timing Spec						
t _{w(POR)}	Internal power-on reset pulse width		0.2			μs

Digital IO Pins (Non-ULPI) (continued)

over operating free-air temperature range (unless otherwise noted)

PARAMETER		TEST CONDITIONS	MIN	TYP	MAX	UNIT
$t_w(\text{RESET})$	External RESETB pulse width	Applied to external RESETB pin when CLOCK is toggling.	8			CLOCK cycles

6.8 PHY Electrical Characteristics

over operating free-air temperature range (unless otherwise noted)

PARAMETER		COMMENTS	MIN	TYP	MAX	UNIT
LS/FS Single-Ended Receivers						
	USB single-ended receivers					
SK_{WVP_VM}	Skew between VP and VM	Driver outputs unloaded	-2	0	2	ns
V_{SE_HYS}	Single-ended hysteresis		50			mV
V_{IH}	High (driven)		2			V
V_{IL}	Low				0.8	V
V_{TH}	Switching threshold		0.8		2	V
LS/FS Differential Receiver						
V_{DI}	Differential input sensitivity	Ref. USB2.0	200			mV
V_{CM}	Differential Common mode range	Ref. USB2.0	0.8		2.5	V
LS Transmitter						
V_{OL}	Low	Ref. USB2.0	0		300	mV
V_{OH}	High (driven)	Ref. USB2.0	2.8		3.6	V
V_{CRS}	Output signal crossover voltage	Ref. USB2.0, covered by eye diagram	1.3		2	V
t_r	Rise time	Ref. USB2.0, covered by eye diagram	75		300	ns
t_f	Fall time		75		300	ns
t_{FRFM}	Differential rise and fall time matching		80%		125%	
t_{FDRATE}	Low-speed data rate	Ref. USB2.0, covered by eye diagram	1.4775		1.5225	Mb/s
t_{DJ1}	Source jitter total (including frequency tolerance)	To next transition	-25		25	ns
t_{DJ2}		For paired transitions	-10		10	
t_{FEOPT}	Source SE0 interval of EOP	Ref. USB2.0, covered by eye diagram	1.25		1.5	μ s
	Downstream eye diagram	Ref. USB2.0, covered by eye diagram				
V_{CM}	Differential common mode range	Ref. USB2.0	0.8		2.5	V
FS Transmitter						
V_{OL}	Low	Ref. USB2.0	0		300	mV
V_{OH}	High (driven)	Ref. USB2.0	2.8		3.6	V
V_{CRS}	Output signal crossover voltage	Ref. USB2.0, covered by eye diagram	1.3		2	V
t_{FR}	Rise time	Ref. USB2.0	4		20	ns
t_{FF}	Fall time	Ref. USB2.0	4		20	ns
t_{FRFM}	Differential rise and fall time matching	Ref. USB2.0, covered by eye diagram	90%		111.11%	
Z_{DRV}	Driver output resistance	Ref. USB2.0	28		44	Ω
T_{FDRATE}	Full-speed data rate	Ref. USB2.0, covered by eye diagram	11.97		12.03	Mb/s
t_{DJ1}	Source jitter total (including frequency tolerance)	To next transition	-2		2	ns
t_{DJ2}		For paired transitions	-1		1	
T_{FEOPT}	Source SE0 interval of EOP	Ref. USB2.0, covered by eye diagram	160		175	ns
	Downstream eye diagram	Ref. USB2.0, covered by eye diagram				

PHY Electrical Characteristics (continued)

over operating free-air temperature range (unless otherwise noted)

PARAMETER		COMMENTS	MIN	TYP	MAX	UNIT
	Upstream eye diagram					
HS Differential Receiver						
VHSSQ	High-speed squelch detection threshold (differential signal amplitude)	Ref. USB2.0	100		150	mV
VHSDSC	High-speed disconnect detection threshold (differential signal amplitude)	Ref. USB2.0	525		625	mV
	High-speed differential input signaling levels	Ref. USB2.0, specified by eye pattern templates				mV
VHSCM	High-speed data signaling common mode voltage range (guidelines for receiver)	Ref. USB2.0	-50		500	mV
	Receiver jitter tolerance	Ref. USB2.0, specified by eye pattern templates			150	ps
HS Transmitter						
V _{HSOI}	High-speed idle level	Ref. USB2.0	-10		10	mV
V _{HSOH}	High-speed data signaling high	Ref. USB2.0	360		440	mV
V _{HSOL}	High-speed data signaling low	Ref. USB2.0	-10		10	mV
VCHIRPJ	Chirp J level (differential voltage)	Ref. USB2.0	700		1100	mV
VCHIRPK	Chirp K level (differential voltage)	Ref. USB2.0	-900		-500	mV
t _r	Rise Time (10% - 90%)	Ref. USB2.0, covered by eye diagram	500			ps
t _f	Fall time (10% - 90%)	Ref. USB2.0, covered by eye diagram	500			ps
ZHSDRV	Driver output resistance (which also serves as high-speed termination)	Ref. USB2.0	40.5		49.5	Ω
THSDRAT	High-speed data range	Ref. USB2.0, covered by eye diagram	479.76		480.24	Mb/s
	Data source jitter	Ref. USB2.0, covered by eye diagram				
	Downstream eye diagram	Ref. USB2.0, covered by eye diagram				
	Upstream eye diagram	Ref. USB2.0, covered by eye diagram				
CEA-2011/UART Transceiver						
	UART Transmitter CEA-2011					
t _{PH_UART_EDGE}	Phone UART edge rates	DP_PULLDOWN asserted			1	Ms
V _{OH_SER}	Serial interface output high	ISOURCE = 4 mA	2.4	3.3	3.6	V
V _{OL_SER}	Serial interface output low	ISINK = -4 mA	0	0.1	0.4	V
	UART Receiver CEA-2011					
V _{IH_SER}	Serial interface input high	DP_PULLDOWN asserted	2			V
V _{IL_SER}	Serial interface input low	DP_PULLDOWN asserted			0.8	V
V _{TH}	Switching threshold		0.8		2	V

6.9 Pullup/Pulldown Resistors

over operating free-air temperature range (unless otherwise noted)

PARAMETER		COMMENTS	MIN	TYP	MAX	UNIT
RPUI	Bus pullup resistor on upstream port (idle bus)	Bus idle	0.9	1.1	1.575	kΩ
RPUA	Bus pullup resistor on upstream port (receiving)	Bus driven/driver's outputs unloaded	1.425	2.2	3.09	
VIHZ	High (floating)	Pullups/pulldowns on both DP and DM lines	2.7		3.6	V
VPH_DP_UP	Phone D+ pullup voltage	Driver's outputs unloaded	3	3.3	3.6	V
	Pulldown resistors					
RPH_DP_DWN	Phone D+/- pulldown	Driver's outputs unloaded	14.25	18	24.8	kΩ
RPH_DM_DWN						
V _{IHZ}	High (floating)	Pullups/pulldowns on both DP and DM lines	2.7		3.6	V
	D+/- Data line					
C _{INUB}	Upstream facing port	[1.0]		22	75	pF
V _{OTG_DATA_LKG}	On-the-go device leakage	[2]			0.342	V
Z _{INP}	Input impedance exclusive of pullup/pulldown	Driver's outputs unloaded	300			kΩ

6.10 OTG Electrical Characteristics

over operating free-air temperature range (unless otherwise noted)

PARAMETER		COMMENTS	MIN	TYP	MAX	UNIT
OTG V _{BUS} Electrical						
V_{BUS} Comparators						
VA_SESS_VLD	A-device session valid		0.8	1.4	2.0	V
VA_VBUS_VLD	A-device V _{BUS} valid		4.4	4.5	4.625	V
VB_SESS_END	B-device session end		0.2	0.5	0.8	V
VB_SESS_VLD	B-device session valid		2.1	2.4	2.7	V
V_{BUS} Line						
RA_BUS_IN	A-device V _{BUS} input impedance to ground	SRP (V _{BUS} pulsing) capable A-device not driving V _{BUS}	40	70	100	kΩ
RB_SRP_DWN	B-device V _{BUS} SRP pulldown	5.25 V / 8 mA, Pullup voltage = 3 V	0.656	10		kΩ
RB_SRP_UP	B-device V _{BUS} SRP pullup	(5.25 V – 3 V) / 8 mA, Pullup voltage = 3 V	0.281	1	2	kΩ
t _{RISE_SRP_UP_MAX}	B-device V _{BUS} SRP rise time maximum for OTG-A communication	0 to 2.1 V with < 13 μF load	RV _{BUS} = 0 Ω and R1KSERIES = '0'		31.4	ms
			RV _{BUS} = 1000 Ω ±10% and R1KSERIES = '1'		57.8	
			RV _{BUS} = 1200 Ω ±10% and R1KSERIES = '1'		64	
			RV _{BUS} = 1800 Ω ±10% and R1KSERIES = '1'		85.4	
t _{RISE_SRP_UP_MIN}	B-device V _{BUS} SRP rise time minimum for standard host connection	0.8 to 2 V with > 97 μF load	RV _{BUS} = 0 Ω and R1KSERIES = '0'	46.2		ms
			RV _{BUS} = 1000 Ω ±10% and R1KSERIES = '1'	96		
			RV _{BUS} = 1200 Ω ±10% and R1KSERIES = '1'	100		
			RV _{BUS} = 1800 Ω ±10% and R1KSERIES = '1'	100		

Table 1. OTG ID Electrical

PARAMETER		COMMENTS	MIN	TYP	MAX	UNIT
ID Comparators — ID External Resistors Specifications						
R _{ID_GND}	ID ground comparator	ID_GND interrupt	12	20	28	kΩ
R _{ID_FLOAT}	ID Float comparator	ID_FLOAT interrupt	200		500	kΩ
ID Line						
R _{PH_ID_UP}	Phone ID pullup to VPH_ID_UP	ID unloaded (V _{RUSB})	70	90	286	kΩ
V _{PH_ID_UP}	Phone ID pullup voltage	Connected to V _{RUSB}	2.5		3.2	V
	ID line maximum voltage				5.25	V

6.11 Power Characteristics

over operating free-air temperature range (unless otherwise noted)

PARAMETER		TEST CONDITIONS	MIN	TYP	MAX	UNIT	
V_{DD33} Internal LDO Regulator Characteristics							
V _{INVDD33}	Input voltage	V _{BAT} USB	V _{VDD33} typ + 0.2	3.6	4.5	V	
V _{VDD33}	Output voltage	ON mode,	VUSB3V3_VSEL = '000	2.4	2.5	2.6	V
			VUSB3V3_VSEL = '001	2.65	2.75	2.85	
			VUSB3V3_VSEL = '010	2.9	3.0	3.1	
			VUSB3V3_VSEL = '011 (default)	3.0	3.1	3.2	
			VUSB3V3_VSEL = '100	3.1	3.2	3.3	
			VUSB3V3_VSEL = '101	3.2	3.3	3.4	
			VUSB3V3_VSEL = '110	3.3	3.4	3.5	
			VUSB3V3_VSEL = '111	3.4	3.5	3.6	
I _{VDD33}	Rated output current	V _{BAT} USB	Active mode		15	mA	
			Suspend/reset mode		1		
V_{DD15} Internal LDO Regulator Characteristics							
V _{IN VDD15}	Input voltage	On mode, V _{IN VDD15} = V _{BAT}	2.7	3.6	4.5	V	
V _{VDD15}	Output voltage	V _{INVDD15 min} – V _{INVDD15 max}	1.45	1.56	1.65	V	
I _{VDD15}	Rated output current	On mode			30	mA	

6.12 Switching Characteristics

over operating free-air temperature range (unless otherwise noted)

PARAMETER		TEST CONDITIONS	MIN	TYP	MAX	UNIT
Electrical Characteristics: Clock Input						
	Clock input duty cycle		40		60%	
f _{CLK}	Clock nominal frequency			60		MHz
	Clock input rise/fall time	In % of clock period t _{CLK} (= 1/f _{CLK})			10%	
	Clock input frequency accuracy				250	ppm
	Clock input integrated jitter				600	ps rms
Electrical Characteristics: REFCLK						
	REFCLK input duty cycle		40		60%	
f _{REFCLK}	REFCLK nominal frequency	When CFG pin is tied to GND		19.2		MHz
		When CFG pin is tied to V _{DDIO}		26		
	REFCLK input rise/fall time	In % of clock period t _{REFCLK} (= 1/f _{REFCLK})			20%	
	REFCLK input frequency accuracy				250	ppm
	REFCLK input integrated jitter				600	ps rms
	REFCLK HIZ Leakage current				3	μA
	REFCLK HIZ Leakage current		-3			
Digital IO Electrical Characteristics: CLOCK						
t _r	Rise time	Frequency = 60 MHz, Load = 10 pF			1	ns
t _f	Fall time	Frequency = 30 MHz, Load = 10 pF			1	ns
Digital IO Electrical Characteristics: STP, DIR, NXT, DATA0 to DATA7						
t _r	Rise time	Frequency = 30 MHz, Load = 10 pF			1	ns
t _f	Fall time				1	ns

6.13 Timing Requirements

PARAMETER		INPUT CLOCK		OUTPUT CLOCK		UNIT
		MIN	MAX	MIN	MAX	
ULPI Interface Timing						
t_{SC}, t_{SD}	Set-up time (control in, 8-bit data in)		3	6		ns
t_{SC}, t_{HD}	Hold time (control in, 8-bit data in)	1.5		0		ns
t_{DC}, t_{DD}	Output delay (control out, 8-bit data out)		6	9		ns
USB UART Interface Timing						
$t_{PH_DP_CON}$	Phone D+ connect time	100				ms
$t_{PH_DISC_DET}$	Phone D+ disconnect time	150				ms
f_{UART_DFLT}	Default UART signaling rate (typical rate)		9600			bps

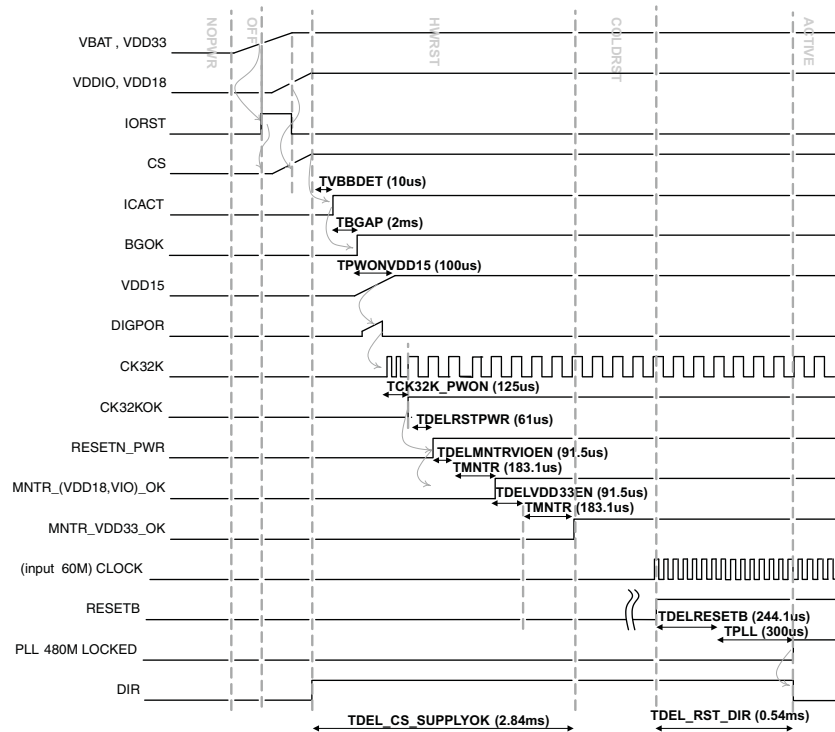

Figure 1. TUSB1210-Q1 Power-Up Timing (ULPI Clock Input Mode)

Table 2. Timers and Debounce

PARAMETER	COMMENTS	MIN	TYP	MAX	UNIT
$t_{DEL_CS_SUPPLYOK}$	Chip-select-to-supplies OK delay		2.84	4.10	ms
$t_{DEL_RST_DIR}$	RESETB to PHY PLL locked and DIR falling-edge delay		0.54	0.647	ms
t_{VBDET}	V_{BAT} detection delay		10		μ s
t_{BGAP}	Bandgap power-on delay		2		ms
$t_{PWONVDD15}$	V_{DD15} power-on delay		100		μ s
$t_{PWONCK32K}$	32-KHz RC-OSC power-on delay		125		μ s
$t_{DELRSTPWR}$	Power control reset delay		61		μ s
$t_{DELMNTRVIOEN}$	Monitor enable delay		91.5		μ s
t_{MNTR}	Supply monitoring debounce		183.1		μ s
$t_{DELVDD33EN}$	V_{DD33} LDO enable delay		93.75		μ s
$t_{DELRESETB}$	RESETB internal delay		244.1		μ s
t_{PLL}	PLL lock time		300		μ s

6.13.1 Timing Parameter Definitions

The timing parameter symbols used in the timing requirement and switching characteristic tables are created in accordance with JEDEC Standard 100. To shorten the symbols, some pin names and other related terminologies have been abbreviated as shown in [Table 3](#).

Table 3. Timing Parameter Definitions

LOWERCASE SUBSCRIPTS	
SYMBOL	PARAMETER
C	Cycle time (period)
D	Delay time
Dis	Disable time
En	Enable time
H	Hold time
Su	Setup time
START	Start bit
T	Transition time
V	Valid time
W	Pulse duration (width)
X	Unknown, changing, or don't care level
H	High
L	Low
V	Valid
IV	Invalid
AE	Active edge
FE	First edge
LE	Last edge
Z	High impedance

6.13.2 Interface Target Frequencies

[Table 4](#) assumes testing over the recommended operating conditions.

Table 4. TUSB1210-Q1 Interface Target Frequencies

IO INTERFACE	INTERFACE DESIGNATION		TARGET FREQUENCY 1.5 V
USB	Universal serial bus	High speed	480 Mbits/s
		Full speed	12 Mbits/s
		Low speed	1.5 Mbits/s

6.14 Typical Characteristics

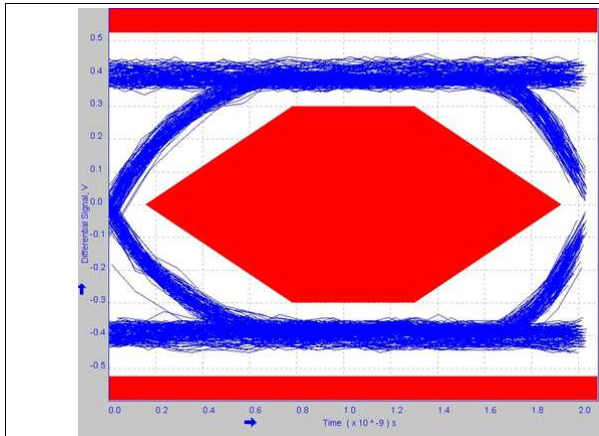

Figure 2. High-Speed Eye Diagram

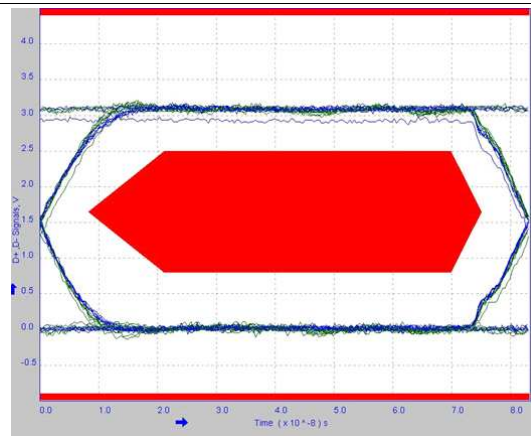

Figure 3. Full-Speed Eye Diagram

7 Detailed Description

7.1 Overview

The TUSB1210-Q1 is a USB2.0 transceiver chip, designed to interface with a USB controller via a ULPI interface. It supports all USB2.0 data rates High-Speed, Full-Speed, and Low-Speed. Compliant to both Host and Peripheral (OTG) modes. It additionally supports a UART mode and legacy ULPI serial modes. TUSB1210-Q1 Integrates a 3.3-V LDO, which makes it flexible to work with either battery operated systems or pure 3.3 V supplied systems. Also, it has an integrated PLL Supporting 2 Clock Frequencies 19.2 MHz/26 MHz. The ULPI clock pin (60 MHz) supports both input and output clock configurations. TUSB1210-Q1 has low power consumption, optimized for portable devices, and complete USB OTG Physical Front-End that supports Host Negotiation Protocol (HNP) and Session Request Protocol (SRP).

TUSB1210-Q1 is optimized to be interfaced through a 12-pin SDR UTMI Low Pin Interface (ULPI), supporting both input clock and output clock modes, with 1.8 V interface supply voltage.

TUSB1210-Q1 integrates a 3.3 V LDO, which makes it flexible to work with either battery operated systems or pure 3.3 V supplied systems. Both the main supply and the 3.3 V power domain can be supplied through an external switched-mode converter for optimized power efficiency.

TUSB1210-Q1 includes a POR circuit to detect supply presence on V_{BAT} and V_{DDIO} pins. TUSB1210-Q1 can be disabled or configured in low power mode for energy saving.

TUSB1210-Q1 is protected against accidental shorts to 5 V or ground on its exposed interface (DP/DM/ID). It is also protected against up to 20 V surges on V_{BUS} .

TUSB1210-Q1 integrates a high-performance low-jitter 480 MHz PLL and supports two clock configurations. Depending on the required link configuration, TUSB1210-Q1 supports both ULPI input and output clock mode : input clock mode, in which case a square-wave 60 MHz clock is provided to TUSB1210-Q1 at the ULPI interface CLOCK pin; and output clock mode in which case TUSB1210-Q1 can accept a square-wave reference clock at REFCLK of either 19.2 MHz, 26 MHz. Frequency is indicated to TUSB1210-Q1 via the configuration pin CFG. This can be useful if a reference clock is already available in the system.

7.2 Functional Block Diagram

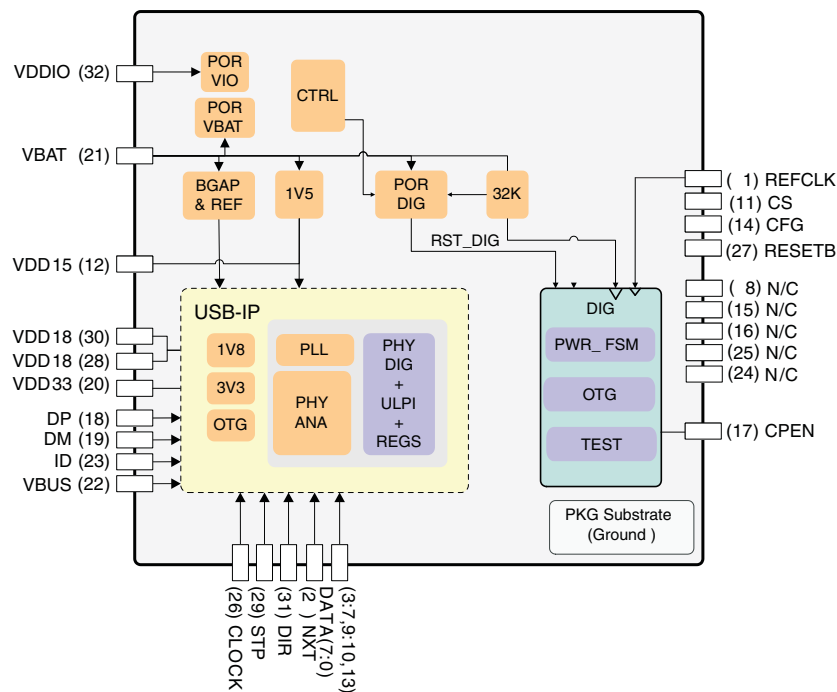

7.3 Feature Description

7.3.1 Processor Subsystem

7.3.1.1 Clock Specifications

7.3.1.1.1 USB PLL Reference Clock

The USB PLL block generates the clocks used to synchronize :

- the ULPI interface (60 MHz clock)
- the USB interface (depending on the USB data rate, 480 Mbps, 12 Mbps or 1.5 Mbps)

TUSB1210-Q1 requires an external reference clock which is used as an input to the 480 MHz USB PLL block. Depending on the clock configuration, this reference clock can be provided either at REFCLK pin or at CLOCK pin. By default CLK pin is configured as an input.

Two clock configurations are possible:

- Input clock configuration (see [ULPI Input Clock Configuration](#))
- Output clock configuration (see [ULPI Output Clock Configuration](#))

7.3.1.1.2 ULPI Input Clock Configuration

In this mode REFCLK must be externally tied to GND. CLOCK remains configured as an input.

When the ULPI interface is used in input clock configuration, that is, the 60 MHz ULPI clock is provided to TUSB1210-Q1 on Clock pin, then this is used as the reference clock for the 480 MHz USB PLL block. See [Switching Characteristics](#).

7.3.1.1.3 ULPI Output Clock Configuration

In this mode a reference clock must be externally provided on REFCLK pin. When an input clock is detected on REFCLK pin then CLK will automatically change to an output, i.e., 60 MHz ULPI clock is output by TUSB1210-Q1 on CLK pin.

Two reference clock input frequencies are supported. REFCLK input frequency is communicated to TUSB1210-Q1 via a configuration pin, CFG, see f_{REFCLK} in [Table 11](#) for frequency correspondence. TUSB1210-Q1 supports square-wave reference clock input only. Reference clock input must be square-wave of amplitude in the range 3 V to 3.6 V. See [Switching Characteristics](#).

7.3.1.1.4 Clock 32 kHz

An internal clock generator running at 32 kHz has been implemented to provide a low-speed, low-power clock to the system. See [Clock 32 kHz](#).

7.3.1.1.5 Reset

All logic is reset if CS = 0 or V_{BAT} are not present.

All logic (except 32 kHz logic) is reset if V_{DDIO} is not present.

PHY logic is reset when any supplies are not present (V_{DDIO} , V_{DD15} , V_{DD18} , V_{DD33}) or if RESETB pin is low.

TUSB1210-Q1 may be reset manually by toggling the RESETB pin to GND for at least 200 ns.

If manual reset via RESETB is not required then RESETB pin may be tied to V_{DDIO} permanently.

7.3.1.2 USB Transceiver

The TUSB1210-Q1 device includes a universal serial bus (USB) on-the-go (OTG) transceiver that supports USB 480 Mb/s high-speed (HS), 12 Mb/s full-speed (FS), and USB 1.5 Mb/s low-speed (LS) through a 12-pin UTMI+ low pin interface (ULPI).

Feature Description (continued)

NOTE

LS device mode is not allowed by a USB2.0 HS capable PHY, therefore it is not supported by TUSB1210-Q1. This is stated in USB2.0 standard Chapter 7, page 119, second paragraph: “A high-speed capable upstream facing transceiver must not support low-speed signaling mode.” There is also some related commentary in Chapter 7.1.2.3.

7.3.1.2.1 PHY Electrical Characteristics

The PHY is the physical signaling layer of the USB 2.0. It essentially contains all the drivers and receivers required for physical data and protocol signaling on the DP and DM lines.

The PHY interfaces to the USB controller through a standard 12-pin digital interface called UTMI+ low pin interface (ULPI).

The transmitters and receivers inside the PHY are classified into two main classes.

- The full-speed (FS) and low-speed (LS) transceivers. These are the legacy USB1.x transceivers.
- The HS (HS) transceivers

In order to bias the transistors and run the logic, the PHY also contains reference generation circuitry which consists of:

- A DPLL which does a frequency multiplication to achieve the 480-MHz low-jitter lock necessary for USB and also the clock required for the switched capacitor resistance block.
- A switched capacitor resistance block which is used to replicate an external resistor on chip.

Built-in pullup and pulldown resistors are used as part of the protocol signaling.

Apart from this, the PHY also contains circuitry which protects it from accidental 5-V short on the DP and DM lines.

7.3.1.2.1.1 LS/FS Single-Ended Receivers

In addition to the differential receiver, there is a single-ended receiver (SE–, SE+) for each of the two data lines D+/- . The main purpose of the single-ended receivers is to qualify the D+ and D– signals in the full-speed/low-speed modes of operation. See [PHY Electrical Characteristics](#).

7.3.1.2.1.2 LS/FS Differential Receiver

A differential input receiver (Rx) retrieves the LS/FS differential data signaling. The differential voltage on the line is converted into digital data by a differential comparator on DP/DM. This data is then sent to a clock and data recovery circuit which recovers the clock from the data. An additional serial mode exists in which the differential data is directly output on the RXRCV pin. See [Switching Characteristics](#).

7.3.1.2.1.3 LS/FS Transmitter

The USB transceiver (Tx) uses a differential output driver to drive the USB data signal D+/- onto the USB cable. The driver's outputs support 3-state operation to achieve bidirectional half-duplex transactions. See [Switching Characteristics](#).

7.3.1.2.1.4 HS Differential Receiver

The HS receiver consists of the following blocks:

A differential input comparator to receive the serial data

- A squelch detector to qualify the received data
- An oversampler-based clock data recovery scheme followed by a NRZI decoder, bit unstuffing, and serial-to-parallel converter to generate the ULPI DATAOUT

See [Switching Characteristics](#).

Feature Description (continued)

7.3.1.2.1.5 HS Differential Transmitter

The HS transmitter is always operated via the ULPI parallel interface. The parallel data on the interface is serialized, bit stuffed, NRZI encoded, and transmitted as a dc output current on DP or DM depending on the data. Each line has an effective 22.5-Ω load to ground, which generates the voltage levels for signaling.

A disconnect detector is also part of the HS transmitter. A disconnect on the far end of the cable causes the impedance seen by the transmitter to double thereby doubling the differential amplitude seen on the DP/DM lines of [Switching Characteristics](#).

7.3.1.2.1.6 UART Transceiver

In this mode, the ULPI data bus is redefined as a 2-pin UART interface, which exchanges data through a direct access to the FS/LS analog transmitter and receiver. See [Switching Characteristics](#).

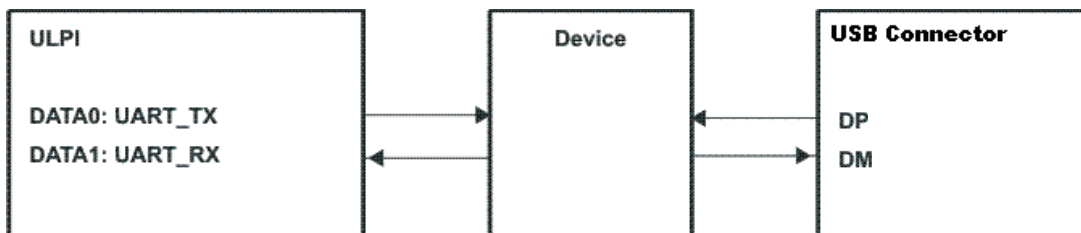

Figure 4. USB UART Data Flow

7.3.1.2.2 OTG Characteristics

The on-the-go (OTG) block integrates three main functions:

- The USB plug detection function on V_{BUS} and ID
- The ID resistor detection
- The V_{BUS} level detection

See [OTG Electrical Characteristics](#).

7.4 Device Functional Modes

7.4.1 TUSB1210-Q1 Modes vs ULPI Pin Status

Table 5, Table 6, and Table 7 show the status of each of the 12 ULPI pins including input/output direction and whether output pins are driven to '0' or to '1', or pulled up/pulled down via internal pullup/pulldown resistors.

Note that pullup/pulldown resistors are automatically replaced by driven '1'/'0' levels respectively once internal IORST is released, with the exception of the pullup on STP which is maintained in all modes.

Pin assignment changes in ULPI 3-pin serial mode, ULPI 6-pin serial mode, and UART mode. Unused pins are tied low in these modes as shown below.

Table 5. TUSB1210-Q1 Modes vs ULPI Pin Status:ULPI Synchronous Mode Power-Up

		ULPI SYNCHRONOUS MODE POWER-UP							
		UNTIL IORST RELEASE		PLL OFF		PLL ON + STP HIGH		PLL ON + STP LOW	
PIN NO.	PIN NAME	DIR	PU/PD	DIR	PU/PD	DIR	PU/PD	DIR	PU/PD
26	CLOCK	Hiz	PD	I	PD	IO	-	IO	-
31	DIR	Hiz	PU	O, ('1')	-	O, ('0')	-	O	-
2	NXT	Hiz	PD	O, ('0')	-	O, ('0')	-	O	-
29	STP	Hiz	PU	I	PU	I	PU	I	PU
3	DATA0	Hiz	PD	O, ('0')	-	I	PD	IO	-
4	DATA1	Hiz	PD	O, ('0')	-	I	PD	IO	-
5	DATA2	Hiz	PD	O, ('0')	-	I	PD	IO	-
6	DATA3	Hiz	PD	O, ('0')	-	I	PD	IO	-
7	DATA4	Hiz	PD	O, ('0')	-	I	PD	IO	-
9	DATA5	Hiz	PD	O, ('0')	-	I	PD	IO	-
10	DATA6	Hiz	PD	O, ('0')	-	I	PD	IO	-
13	DATA7	Hiz	PD	O, ('0')	-	I	PD	IO	-

Table 6. TUSB1210-Q1 Modes vs ULPI Pin Status: USB Suspend Mode

		SUSPEND MODE		LINK / EXTERNAL RECOMMENDED SETTING DURING SUSPEND MODE	
		DIR	PU/PD	DIR	PU/PD
26	CLOCK	I	-	O	-
31	DIR	O, ('1')	-	I	-
2	NXT	O, ('0')	-	I	-
29	STP	I	PU ⁽¹⁾	O, ('0')	-
3	DATA0	O, (LINESTATE0)	-	I	-
4	DATA1	O, (LINESTATE1)	-	I	-
5	DATA2	O, ('0')	-	I	-
6	DATA3	O, (INT)	-	I	-
7	DATA4	O, ('0')	-	I	-
9	DATA5	O, ('0')	-	I	-
10	DATA6	O, ('0')	-	I	-
13	DATA7	O, ('0')	-	I	-

(1) Can be disabled by software before entering Suspend Mode to reduce current consumption

Table 7. TUSB1210-Q1 Modes vs ULPI Pin Status: ULPI 6-Pin Serial Mode and UART Mode

PIN NO.	ULPI 6-PIN SERIAL MODE			ULPI 3-PIN SERIAL MODE			UART MODE		
	PIN NAME	DIR	PU/PD	PIN NAME	DIR	PU/PD	PIN NAME	DIR	PU/PD
26	CLOCK (1)	IO	-	CLOCK (1)	IO	-	CLOCK (1)	IO	-
31	DIR	O	-	DIR	O	-	DIR	O	-
2	NXT	O	-	NXT	O	-	NXT	O	-
29	STP	I	PU	STP	I	PU	STP	I	PU
3	TX_ENABLE	I	-	TX_ENABLE	I	-	TXD	I	-
4	TX_DAT	I	-	DAT	IO	-	RXD	IO	-
5	TX_SE0	I	-	SE0	IO	-	tie low	O	-
6	INT	O	-	INT	O	-	INT	O	-
7	RX_DP	O	-	tie low	O	-	tie low	O	-
9	RX_DM	O	-	tie low	O	-	tie low	O	-
10	RX_RCV	O	-	tie low	O	-	tie low	O	-
13	tie low	O	-	tie low	O	-	tie low	O	-

7.5 Register Map

Table 8. USB Register Summary

REGISTER NAME	TYPE	REGISTER WIDTH (BITS)	PHYSICAL ADDRESS
VENDOR_ID_LO	R	8	0x00
VENDOR_ID_HI	R	8	0x01
PRODUCT_ID_LO	R	8	0x02
PRODUCT_ID_HI	R	8	0x03
FUNC_CTRL	RW	8	0x04
FUNC_CTRL_SET	RW	8	0x05
FUNC_CTRL_CLR	RW	8	0x06
IFC_CTRL	RW	8	0x07
IFC_CTRL_SET	RW	8	0x08
IFC_CTRL_CLR	RW	8	0x09
OTG_CTRL	RW	8	0x0A
OTG_CTRL_SET	RW	8	0x0B
OTG_CTRL_CLR	RW	8	0x0C
USB_INT_EN_RISE	RW	8	0x0D
USB_INT_EN_RISE_SET	RW	8	0x0E
USB_INT_EN_RISE_CLR	RW	8	0x0F
USB_INT_EN_FALL	RW	8	0x10
USB_INT_EN_FALL_SET	RW	8	0x11
USB_INT_EN_FALL_CLR	RW	8	0x12
USB_INT_STS	R	8	0x13
USB_INT_LATCH	R	8	0x14
DEBUG	R	8	0x15
SCRATCH_REG	RW	8	0x16
SCRATCH_REG_SET	RW	8	0x17
SCRATCH_REG_CLR	RW	8	0x18
Reserved	R	8	0x19 0x2E
ACCESS_EXT_REG_SET	RW	8	0x2F
Reserved	R	8	0x30 0x3C
VENDOR_SPECIFIC1	RW	8	0x3D
VENDOR_SPECIFIC1_SET	RW	8	0x3E
VENDOR_SPECIFIC1_CLR	RW	8	0x3F
VENDOR_SPECIFIC2	RW	8	0x80
VENDOR_SPECIFIC2_SET	RW	8	0x81
VENDOR_SPECIFIC2_CLR	RW	8	0x82
VENDOR_SPECIFIC1_STS	R	8	0x83
VENDOR_SPECIFIC1_LATCH	R	8	0x84
VENDOR_SPECIFIC3	RW	8	0x85
VENDOR_SPECIFIC3_SET	RW	8	0x86
VENDOR_SPECIFIC3_CLR	RW	8	0x87

7.5.1 VENDOR_ID_LO

ADDRESS OFFSET		0x00					
PHYSICAL ADDRESS		0x00			INSTANCE		USB_SCUSB
DESCRIPTION		Lower byte of vendor ID supplied by USB-IF (TI Vendor ID = 0x0451)					
TYPE		R					
WRITE LATENCY							
7	6	5	4	3	2	1	0
VENDOR_ID							
BITS	FIELD NAME	DESCRIPTION	TYPE	RESET			
7:00	VENDOR_ID		R	0x51			

7.5.2 VENDOR_ID_HI

ADDRESS OFFSET		0x01					
PHYSICAL ADDRESS		0x01			INSTANCE		USB_SCUSB
DESCRIPTION		Upper byte of vendor ID supplied by USB-IF (TI Vendor ID = 0x0451)					
TYPE		R					
WRITE LATENCY							
7	6	5	4	3	2	1	0
VENDOR_ID							
BITS	FIELD NAME	DESCRIPTION	TYPE	RESET			
7:00	VENDOR_ID		R	0x04			

7.5.3 PRODUCT_ID_LO

ADDRESS OFFSET		0x02					
PHYSICAL ADDRESS		0x02			INSTANCE		USB_SCUSB
DESCRIPTION		Lower byte of Product ID supplied by Vendor (TUSB1210-Q1 Product ID is 0x1507).					
TYPE		R					
WRITE LATENCY							
7	6	5	4	3	2	1	0
PRODUCT_ID							
BITS	FIELD NAME	DESCRIPTION	TYPE	RESET			
7:00	PRODUCT_ID		R	0x07			

TUSB1210-Q1

ZHCSCV8A – SEPTEMBER 2014 – REVISED OCTOBER 2014

www.ti.com.cn
7.5.4 PRODUCT_ID_HI

ADDRESS OFFSET		0x03					
PHYSICAL ADDRESS		0x03			INSTANCE		USB_SCUSB
DESCRIPTION		Upper byte of Product ID supplied by Vendor (TUSB1210-Q1 Product ID is 0x1507).					
TYPE		R					
WRITE LATENCY							
7	6	5	4	3	2	1	0
PRODUCT_ID							
BITS	FIELD NAME		DESCRIPTION		TYPE		RESET
7:00	PRODUCT_ID				R		0x15

7.5.5 FUNC_CTRL

ADDRESS OFFSET		0x04					
PHYSICAL ADDRESS		0x04			INSTANCE		USB_SCUSB
DESCRIPTION		Controls UTMI function settings of the PHY.					
TYPE		RW					
WRITE LATENCY							
7	6	5	4	3	2	1	0
Reserved	SUSPENDM	RESET	OPMODE		TERMSELECT	XCVRSELECT	
BITS	FIELD NAME	DESCRIPTION				TYPE	RESET
7	Reserved					R	0
6	SUSPENDM	Active low PHY suspend. Put PHY into Low Power Mode. In Low Power Mode the PHY power down all blocks except the full speed receiver, OTG comparators, and the ULPI interface pins. The PHY automatically set this bit to '1' when Low Power Mode is exited.				RW	1
5	RESET	Active high transceiver reset. Does not reset the ULPI interface or ULPI register set. Once set, the PHY asserts the DIR signal and reset the UTMI core. When the reset is completed, the PHY de-asserts DIR and clears this bit. After de-asserting DIR, the PHY re-assert DIR and send an RX command update. Note: This bit is auto-cleared, this explain why it can't be read at '1'.				RW	0
4:03	OPMODE	Select the required bit encoding style during transmit 0x0: Normal operation 0x1: Non-driving 0x2: Disable bit-stuff and NRZI encoding 0x3: Reserved (No SYNC and EOP generation feature not supported)				RW	0x0
2	TERMSELECT	Controls the internal 1.5Kohms pull-up resistor and 45ohms HS terminations. Control over bus resistors changes depending on XcvrSelect, OpMode, DpPulldown and DmPulldown.				RW	0
1:00	XCVRSELECT	Select the required transceiver speed. 0x0: Enable HS transceiver 0x1: Enable FS transceiver 0x2: Enable LS transceiver 0x3: Enable FS transceiver for LS packets (FS preamble is automatically pre-pended)				RW	0x1

7.5.6 FUNC_CTRL_SET

ADDRESS OFFSET		0x05					
PHYSICAL ADDRESS		0x05			INSTANCE		USB_SCUSB

DESCRIPTION		This register doesn't physically exist. It is the same as the func_ctrl register with read/set-only property (write '1' to set a particular bit, a write '0' has no-action).					
TYPE		RW					
WRITE LATENCY							
7	6	5	4	3	2	1	0
Reserved	SUSPENDM	RESET	OPMODE		TERMSELECT	XCVRSELECT	
BITS		FIELD NAME		DESCRIPTION		RESET	
7		Reserved				R	
6		SUSPENDM				RW	
5		RESET				RW	
4:03		OPMODE				RW	
2		TERMSELECT				RW	
1:00		XCVRSELECT				RW	

7.5.7 FUNC_CTRL_CLR

ADDRESS OFFSET		0x06					
PHYSICAL ADDRESS		0x06			INSTANCE		USB_SCUSB
DESCRIPTION		This register doesn't physically exist. It is the same as the func_ctrl register with read/clear-only property (write '1' to clear a particular bit, a write '0' has no-action).					
TYPE		RW					
WRITE LATENCY							
7	6	5	4	3	2	1	0
Reserved	SUSPENDM	RESET	OPMODE		TERMSELECT	XCVRSELECT	
BITS		FIELD NAME		DESCRIPTION		RESET	
7		Reserved				R	
6		SUSPENDM				RW	
5		RESET				RW	
4:03		OPMODE				RW	
2		TERMSELECT				RW	
1:00		XCVRSELECT				RW	

TUSB1210-Q1

ZHCSCV8A – SEPTEMBER 2014 – REVISED OCTOBER 2014

www.ti.com.cn

7.5.8 IFC_CTRL

ADDRESS OFFSET		0x07						
PHYSICAL ADDRESS		0x07			INSTANCE		USB_SCUSB	
DESCRIPTION		Enables alternative interfaces and PHY features.						
TYPE		RW						
WRITE LATENCY								
7	6	5	4	3	2	1	0	
INTERFACE_PROTECT_DISABLE	INDICATORPASSTHRU	INDICATORCOMPLEMENT	AUTORESUME	CLOCKSUSPENDM	CARKITMODE	FSLSSERIALMODE_3PIN	FSLSSERIALMODE_6PIN	
BITS	FIELD NAME	DESCRIPTION					TYPE	RESET
7	INTERFACE_PROTECT_DISABLE	Controls circuitry built into the PHY for protecting the ULPI interface when the link tristates stp and data. 0b: Enables the interface protect circuit 1b: Disables the interface protect circuit					RW	0
6	INDICATORPASSTHRU	Controls whether the complement output is qualified with the internal vbusvalid comparator before being used in the VBUS State in the RXCMD. 0b: Complement output signal is qualified with the internal VBUSVALID comparator. 1b: Complement output signal is not qualified with the internal VBUSVALID comparator.					RW	0
5	INDICATORCOMPLEMENT	Tells the PHY to invert EXTERNALVBUSINDICATOR input signal, generating the complement output. 0b: PHY will not invert signal EXTERNALVBUSINDICATOR (default) 1b: PHY will invert signal EXTERNALVBUSINDICATOR					RW	0
4	AUTORESUME	Enables the PHY to automatically transmit resume signaling. Refer to USB specification 7.1.7.7 and 7.9 for more details. 0 = AutoResume disabled 1 = AutoResume enabled (default)					RW	1
3	CLOCKSUSPENDM	Active low clock suspend. Valid only in Serial Modes. Powers down the internal clock circuitry only. Valid only when SuspendM = 1b. The PHY must ignore ClockSuspend when SuspendM = 0b. By default, the clock will not be powered in Serial and Carkit Modes. 0b : Clock will not be powered in Serial and UART Modes. 1b : Clock will be powered in Serial and UART Modes.					RW	0
2	CARKITMODE	Changes the ULPI interface to UART interface. The PHY automatically clear this field when UART mode is exited. 0b: UART disabled. 1b: Enable serial UART mode.					RW	0
1	FSLSSERIALMODE_3PIN	Changes the ULPI interface to 3-pin Serial. The PHY must automatically clear this field when serial mode is exited. 0b: FS/LS packets are sent using parallel interface 1b: FS/LS packets are sent using 4-pin serial interface					RW	0
0	FSLSSERIALMODE_6PIN	Changes the ULPI interface to 6-pin Serial. The PHY must automatically clear this field when serial mode is exited. 0b: FS/LS packets are sent using parallel interface 1b: FS/LS packets are sent using 6-pin serial interface					RW	0

7.5.9 IFC_CTRL_SET

ADDRESS OFFSET		0x08					
PHYSICAL ADDRESS		0x08			INSTANCE		USB_SCUSB
DESCRIPTION		This register doesn't physically exist. It is the same as the ifc_ctrl register with read/set-only property (write '1' to set a particular bit, a write '0' has no-action).					
TYPE		RW					
WRITE LATENCY							

7	6	5	4	3	2	1	0
INTERFACE_P ROTECT_DISA BLE	INDICATORPA SSTHRU	INDICATORCO MPLEMENT	AUTORESUME	CLOCKSUSPE NDM	CARKITMODE	FSLSSERIALM ODE_3PIN	FSLSSERIALM ODE_6PIN
BITS	FIELD NAME		DESCRIPTION		TYPE		RESET
7	INTERFACE_PROTECT_DISABLE				RW		0
6	INDICATORPASSTHRU				RW		0
5	INDICATORCOMPLEMENT				RW		0
4	AUTORESUME				RW		1
3	CLOCKSUSPENDM				RW		0
2	CARKITMODE				RW		0
1	FSLSSERIALMODE_3PIN				RW		0
0	FSLSSERIALMODE_6PIN				R		0

TUSB1210-Q1

ZHCSCV8A – SEPTEMBER 2014 – REVISED OCTOBER 2014

www.ti.com.cn
7.5.10 IFC_CTRL_CLR

ADDRESS OFFSET		0x09					
PHYSICAL ADDRESS		0x09			INSTANCE		USB_SCUSB
DESCRIPTION		This register doesn't physically exist. It is the same as the ifc_ctrl register with read/clear-only property (write '1' to clear a particular bit, a write '0' has no-action).					
TYPE		RW					
WRITE LATENCY							
7	6	5	4	3	2	1	0
INTERFACE_P ROTECT_DISA BLE	IN DICATORPAS STHRU	INDICATORCO MPLEMENT	AUTORESUME	CLOCKSUSPE NDM	CARKITMODE	FSLSSERIALM ODE_3PIN	FSLSSERIALM ODE_6PIN
BITS	FIELD NAME			DESCRIPTION		TYPE	RESET
7	INTERFACE_PROTECT_DISABLE					RW	0
6	INDICATORPASSTHRU					RW	0
5	INDICATORCOMPLEMENT					RW	0
4	AUTORESUME					RW	1
3	CLOCKSSUSPENDM					RW	0
2	CARKITMODE					RW	0
1	FSLSSERIALMODE_3PIN					RW	0
0	FSLSSERIALMODE_6PIN					R	0

7.5.11 OTG_CTRL

ADDRESS OFFSET		0x0A					
PHYSICAL ADDRESS		0x0A			INSTANCE		USB_SCUSB
DESCRIPTION		Controls UTMI+ OTG functions of the PHY.					
TYPE		RW					
WRITE LATENCY							
7	6	5	4	3	2	1	0
USEEXTERNALVBUSINDICATOR	DRVVBUSEXTERNAL	DRVVBUS	CHRGVBUS	DISCHRGVBUS	DMPULLDOWN	DPPULLDOWN	IDPULLUP
BITS	FIELD NAME	DESCRIPTION				TYPE	RESET
7	USEEXTERNALVBUSINDICATOR	Tells the PHY to use an external VBUS over-current indicator. 0b: Use the internal OTG comparator (VA_VBUS_VLD) or internal VBUS valid indicator (default) 1b: Use external VBUS valid indicator signal.				RW	0
6	DRVVBUSEXTERNAL	Selects between the internal and the external 5 V VBUS supply. 0b: Pin17 (CPEN) is disabled (output GND level). TUSB1210-Q1 does not support internal VBUS supply. 1b: Pin17 (CPEN) is set to '1' (output VDD33 voltage level) if DRVVBUS bit is '1', else Pin17 (CPEN) is disabled (output GND level) if DRVVBUS bit is '0'				RW	0
5	DRVVBUS	VBUS output control bit 0b : do not drive VBUS 1b : drive 5V on VBUS Note: Both DRVVBUS and DRVVBUSEXTERNAL bits must be set to 1 in order to set Pin17 (CPEN). CPEN pin can be used to enable an external VBUS supply				RW	0
4	CHRGVBUS	Charge VBUS through a resistor. Used for VBUS pulsing SRP. The Link must first check that VBUS has been discharged (see DischrgVbus register bit), and that both D+ and D- data lines have been low (SE0) for 2ms. 0b : do not charge VBUS 1b : charge VBUS				RW	0
3	DISCHRGVBUS	Discharge VBUS through a resistor. If the Link sets this bit to 1, it waits for an RX CMD indicating SessEnd has transitioned from 0 to 1, and then resets this bit to 0 to stop the discharge. 0b : do not discharge VBUS 1b : discharge VBUS				RW	0
2	DMPULLDOWN	Enables the 15k Ohm pull-down resistor on D-. 0b : Pull-down resistor not connected to D-. 1b : Pull-down resistor connected to D-.				RW	1
1	DPPULLDOWN	Enables the 15k Ohm pull-down resistor on D+. 0b : Pull-down resistor not connected to D+. 1b : Pull-down resistor connected to D+.				RW	1
0	IDPULLUP	Connects a pull-up to the ID line and enables sampling of the signal level. 0b : Disable sampling of ID line. 1b : Enable sampling of ID line.				RW	0

7.5.12 OTG_CTRL_SET

ADDRESS OFFSET		0x0B					
PHYSICAL ADDRESS		0x0B			INSTANCE		USB_SCUSB
DESCRIPTION		This register doesn't physically exist. It is the same as the otg_ctrl register with read/set-only property (write '1' to set a particular bit, a write '0' has no-action).					
TYPE		RW					
WRITE LATENCY							

TUSB1210-Q1

ZHCSCV8A – SEPTEMBER 2014 – REVISED OCTOBER 2014

www.ti.com.cn

7	6	5	4	3	2	1	0
USEEXTERNALV BUSINDICA TOR	DRVVBUSEXT ERNAL	DRVVBUS	CHRGVBUS	DISCHRGVBU S	DMPULLDOW N	DPPULLDOWN	IDPULLUP
BITS	FIELD NAME		DESCRIPTION		TYPE	RESET	
7	USEEXTERNALV BUSINDICATOR				RW	0	
6	DRVVBUSEXT ERNAL				RW	0	
5	DRVVBUS				RW	0	
4	CHRGVBUS				RW	0	
3	DISCHRGVBU S				RW	0	
2	DMPULLDOW N				RW	1	
1	DPPULLDOWN				RW	1	
0	IDPULLUP				RW	0	

7.5.13 OTG_CTRL_CLR

ADDRESS OFFSET		0x0C					
PHYSICAL ADDRESS		0x0C		INSTANCE		USB_SCUSB	
DESCRIPTION		This register doesn't physically exist. It is the same as the otg_ctrl register with read/Clear-only property (write '1' to clear a particular bit, a write '0' has no-action).					
TYPE		RW					
WRITE LATENCY							
7	6	5	4	3	2	1	0
USEEXTERNALV BUSINDICA TOR	DRVVBUSEXT ERNAL	DRVVBUS	CHRGVBUS	DISCHRGVBU S	DMPULLDOW N	DPPULLDOWN	IDPULLUP
BITS	FIELD NAME		DESCRIPTION			TYPE	RESET
7	USEEXTERNALV BUSINDICA TOR					RW	0
6	DRVVBUSEXT ERNAL					RW	0
5	DRVVBUS					RW	0
4	CHRGVBUS					RW	0
3	DISCHRGVBU S					RW	0
2	DMPULLDOW N					RW	1
1	DPPULLDOWN					RW	1
0	IDPULLUP					RW	0

TUSB1210-Q1

ZHCSCV8A – SEPTEMBER 2014 – REVISED OCTOBER 2014

www.ti.com.cn
7.5.14 USB_INT_EN_RISE

ADDRESS OFFSET		0x0D					
PHYSICAL ADDRESS		0x0D			INSTANCE		USB_SCUSB
DESCRIPTION		If set, the bits in this register cause an interrupt event notification to be generated when the corresponding PHY signal changes from low to high. By default, all transitions are enabled.					
TYPE		RW					
WRITE LATENCY							
7	6	5	4	3	2	1	0
Reserved	Reserved	Reserved	IDGND_RISE	SESEND_RISE	SESSVALID_RISE	VBUSVALID_RISE	HOSTDISCONNECT_RISE
BITS	FIELD NAME	DESCRIPTION				TYPE	RESET
7	Reserved					R	0
6	Reserved					R	0
5	Reserved					R	0
4	IDGND_RISE	Generate an interrupt event notification when IdGnd changes from low to high. Event is automatically masked if IdPullup bit is clear to 0 and for 50ms after IdPullup is set to 1.				RW	1
3	SESEND_RISE	Generate an interrupt event notification when SessEnd changes from low to high.				RW	1
2	SESSVALID_RISE	Generate an interrupt event notification when SessValid changes from low to high. SessValid is the same as UTMI+ AValid.				RW	1
1	VBUSVALID_RISE	Generate an interrupt event notification when VbusValid changes from low to high.				RW	1
0	HOSTDISCONNECT_RISE	Generate an interrupt event notification when Hostdisconnect changes from low to high. Applicable only in host mode (DpPulldown and DmPulldown both set to 1b).				RW	1

7.5.15 USB_INT_EN_RISE_SET

ADDRESS OFFSET		0x0E					
PHYSICAL ADDRESS		0x0E			INSTANCE		USB_SCUSB
DESCRIPTION		This register doesn't physically exist. It is the same as the usb_int_en_rise register with read/set-only property (write '1' to set a particular bit, a write '0' has no-action).					
TYPE		RW					
WRITE LATENCY							
7	6	5	4	3	2	1	0
Reserved	Reserved	Reserved	IDGND_RISE	SESEND_RISE	SESSVALID_RISE	VBUSVALID_RISE	HOSTDISCONNECT_RISE
BITS	FIELD NAME		DESCRIPTION		TYPE		RESET
7	Reserved				R		0
6	Reserved				R		0
5	Reserved				R		0
4	IDGND_RISE				RW		1
3	SESEND_RISE				RW		1
2	SESSVALID_RISE				RW		1
1	VBUSVALID_RISE				RW		1
0	HOSTDISCONNECT_RISE				RW		1

TUSB1210-Q1

ZHCSCV8A – SEPTEMBER 2014 – REVISED OCTOBER 2014

www.ti.com.cn
7.5.16 USB_INT_EN_RISE_CLR

ADDRESS OFFSET		0x0F					
PHYSICAL ADDRESS		0x0F			INSTANCE		USB_SCUSB
DESCRIPTION		This register doesn't physically exist. It is the same as the usb_int_en_rise register with read/clear-only property (write '1' to clear a particular bit, a write '0' has no-action).					
TYPE		RW					
WRITE LATENCY							
7	6	5	4	3	2	1	0
Reserved	Reserved	Reserved	IDGND_RISE	SESEND_RISE	SESSVALID_RISE	VBUSVALID_RISE	HOSTDISCONNECT_RISE
BITS	FIELD NAME		DESCRIPTION		TYPE	RESET	
7	Reserved				R	0	
6	Reserved				R	0	
5	Reserved				R	0	
4	IDGND_RISE				RW	1	
3	SESEND_RISE				RW	1	
2	SESSVALID_RISE				RW	1	
1	VBUSVALID_RISE				RW	1	
0	HOSTDISCONNECT_RISE				RW	1	

7.5.17 USB_INT_EN_FALL

ADDRESS OFFSET		0x10					
PHYSICAL ADDRESS		0x10			INSTANCE		USB_SCUSB
DESCRIPTION		If set, the bits in this register cause an interrupt event notification to be generated when the corresponding PHY signal changes from low to high. By default, all transitions are enabled.					
TYPE		RW					
WRITE LATENCY							
7	6	5	4	3	2	1	0
Reserved	Reserved	Reserved	IDGND_FALL	SESEND_FALL	SESSVALID_FALL	VBUSVALID_FALL	HOSTDISCONNECT_FALL
BITS	FIELD NAME	DESCRIPTION				TYPE	RESET
7	Reserved					R	0
6	Reserved					R	0
5	Reserved					R	0
4	IDGND_FALL	Generate an interrupt event notification when IdGnd changes from high to low. Event is automatically masked if IdPullup bit is clear to 0 and for 50ms after IdPullup is set to 1.				RW	1
3	SESEND_FALL	Generate an interrupt event notification when SessEnd changes from high to low.				RW	1
2	SESSVALID_FALL	Generate an interrupt event notification when SessValid changes from high to low. SessValid is the same as UTMI+ AValid.				RW	1
1	VBUSVALID_FALL	Generate an interrupt event notification when VbusValid changes from high to low.				RW	1
0	HOSTDISCONNECT_FALL	Generate an interrupt event notification when Hostdisconnect changes from high to low. Applicable only in host mode (DpPulldown and DmPulldown both set to 1b).				RW	1

TUSB1210-Q1

ZHCSCV8A – SEPTEMBER 2014 – REVISED OCTOBER 2014

www.ti.com.cn
7.5.18 USB_INT_EN_FALL_SET

ADDRESS OFFSET		0x11					
PHYSICAL ADDRESS		0x11			INSTANCE		USB_SCUSB
DESCRIPTION		This register doesn't physically exist. It is the same as the usb_int_en_fall register with read/set-only property (write '1' to set a particular bit, a write '0' has no-action)					
TYPE		RW					
WRITE LATENCY							
7	6	5	4	3	2	1	0
Reserved	Reserved	Reserved	IDGND_FALL	SESSEND_FALL	SESSVALID_FALL	VBUSVALID_FALL	HOSTDISCONNECT_FALL
BITS	FIELD NAME		DESCRIPTION			TYPE	RESET
7	Reserved					R	0
6	Reserved					R	0
5	Reserved					R	0
4	IDGND_FALL					RW	1
3	SESSEND_FALL					RW	1
2	SESSVALID_FALL					RW	1
1	VBUSVALID_FALL					RW	1
0	HOSTDISCONNECT_FALL					RW	1

7.5.19 USB_INT_EN_FALL_CLR

ADDRESS OFFSET	0x12		
PHYSICAL ADDRESS	0x12	INSTANCE	USB_SCUSB
DESCRIPTION	This register doesn't physically exist. It is the same as the usb_int_en_fall register with read/clear-only property (write '1' to clear a particular bit, a write '0' has no-action).		
TYPE	RW		
WRITE LATENCY			

7	6	5	4	3	2	1	0
Reserved	Reserved	Reserved	IDGND_FALL	SESSEND_FALL	SESSVALID_FALL	VBUSVALID_FALL	HOSTDISCONNECT_FALL
BITS	FIELD NAME		DESCRIPTION			TYPE	RESET
7	Reserved					R	0
6	Reserved					R	0
5	Reserved					R	0
4	IDGND_FALL					RW	1
3	SESSEND_FALL					RW	1
2	SESSVALID_FALL					RW	1
1	VBUSVALID_FALL					RW	1
0	HOSTDISCONNECT_FALL					RW	1

TUSB1210-Q1

ZHCSCV8A – SEPTEMBER 2014 – REVISED OCTOBER 2014

www.ti.com.cn
7.5.20 USB_INT_STS

ADDRESS OFFSET		0x13						
PHYSICAL ADDRESS		0x13			INSTANCE		USB_SCUSB	
DESCRIPTION		Indicates the current value of the interrupt source signal.						
TYPE		R						
WRITE LATENCY								
7	6	5	4	3	2	1	0	
Reserved	Reserved	Reserved	IDGND	SESEND	SESSVALID	VBUSVALID	HOSTDISCONNECT	
BITS	FIELD NAME	DESCRIPTION					TYPE	RESET
7	Reserved						R	0
6	Reserved						R	0
5	Reserved						R	0
4	IDGND	Current value of UTMI+ IdGnd output. This bit is not updated if IdPullup bit is reset to 0 and for 50 ms after IdPullup is set to 1.					R	0
3	SESEND	Current value of UTMI+ SessEnd output.					R	0
2	SESSVALID	Current value of UTMI+ SessValid output. SessValid is the same as UTMI+ AValid.					R	0
1	VBUSVALID	Current value of UTMI+ VbusValid output.					R	0
0	HOSTDISCONNECT	Current value of UTMI+ Hostdisconnect output. Applicable only in host mode. Automatically reset to 0 when Low Power Mode is entered. NOTE: Reset value is '0' when host is connected. Reset value is '1' when host is disconnected.					R	0

7.5.21 USB_INT_LATCH

ADDRESS OFFSET		0x14													
PHYSICAL ADDRESS		0x14		INSTANCE	USB_SCUSB										
DESCRIPTION		<p>These bits are set by the PHY when an unmasked change occurs on the corresponding internal signal. The PHY will automatically clear all bits when the Link reads this register, or when Low Power Mode is entered. The PHY also clears this register when Serial Mode or CarKit Mode is entered regardless of the value of ClockSuspendM.</p> <p>The PHY follows the rules defined in Table 26 of the ULPI spec for setting any latch register bit. It is important to note that if register read data is returned to the Link in the same cycle that a USB Interrupt Latch bit is to be set, the interrupt condition is given immediately in the register read data and the Latch bit is not set.</p> <p>Note that it is optional for the Link to read the USB Interrupt Latch register in Synchronous Mode because the RX CMD byte already indicates the interrupt source directly</p>													
TYPE		R													
WRITE LATENCY															
7		6		5		4		3		2		1		0	
Reserved		Reserved		Reserved		IDGND_LATCH	SESEND_LATCH	SESSVALID_LATCH	VBUSVALID_LATCH	HOSTDISCONNECT_LATCH					
BITS	FIELD NAME		DESCRIPTION									TYPE	RESET		
7	Reserved											R	0		
6	Reserved											R	0		
5	Reserved											R	0		
4	IDGND_LATCH		Set to 1 by the PHY when an unmasked event occurs on IdGnd. Cleared when this register is read.									R	0		
3	SESEND_LATCH		Set to 1 by the PHY when an unmasked event occurs on SessEnd. Cleared when this register is read.									R	0		
2	SESSVALID_LATCH		Set to 1 by the PHY when an unmasked event occurs on SessValid. Cleared when this register is read. SessValid is the same as UTMI+ AValid.									R	0		
1	VBUSVALID_LATCH		Set to 1 by the PHY when an unmasked event occurs on VbusValid. Cleared when this register is read.									R	0		
0	HOSTDISCONNECT_LATCH		Set to 1 by the PHY when an unmasked event occurs on Hostdisconnect. Cleared when this register is read. Applicable only in host mode. NOTE: As this IT is enabled by default, the reset value depends on the host status Reset value is '0' when host is connected. Reset value is '1' when host is disconnected.									R	0		

TUSB1210-Q1

ZHCSCV8A – SEPTEMBER 2014 – REVISED OCTOBER 2014

www.ti.com.cn
7.5.22 DEBUG

ADDRESS OFFSET	0x15		
PHYSICAL ADDRESS	0x15	INSTANCE	USB_SCUSB
DESCRIPTION	Indicates the current value of various signals useful for debugging.		
TYPE	R		
WRITE LATENCY			

7	6	5	4	3	2	1	0
Reserved						LINESTATE	
BITS	FIELD NAME	DESCRIPTION				TYPE	RESET
7	Reserved					R	0
6	Reserved					R	0
5	Reserved					R	0
4	Reserved					R	0
3	Reserved					R	0
2	Reserved					R	0
1:00	LINESTATE	<p>These signals reflect the current state of the single ended receivers. They directly reflect the current state of the DP (LineState[0]) and DM (LineState[1]) signals.</p> <p>Read 0x0: SE0 (LS/FS), Squelch (HS/Chirp)</p> <p>Read 0x1: LS: 'K' State, FS: 'J' State, HS: !Squelch, Chirp: !Squelch & HS_Differential_Receiver_Output</p> <p>Read 0x2: LS: 'J' State, FS: 'K' State, HS: Invalid, Chirp: !Squelch & !HS_Differential_Receiver_Output</p> <p>Read 0x3: SE1 (LS/FS), Invalid (HS/Chirp)</p>				R	0x0

7.5.23 SCRATCH_REG

ADDRESS OFFSET	0x16		
PHYSICAL ADDRESS	0x16	INSTANCE	USB_SCUSB
DESCRIPTION	Empty register byte for testing purposes. Software can read, write, set, and clear this register and the PHY functionality will not be affected.		
TYPE	RW		
WRITE LATENCY			

7	6	5	4	3	2	1	0
SCRATCH							
BITS	FIELD NAME	DESCRIPTION				TYPE	RESET
7:00	SCRATCH	Scratch data.				RW	0x00

7.5.24 SCRATCH_REG_SET

ADDRESS OFFSET	0x17		
PHYSICAL ADDRESS	0x17	INSTANCE	USB_SCUSB
DESCRIPTION	This register doesn't physically exist. It is the same as the scratch_reg register with read/set-only property (write '1' to set a particular bit, a write '0' has no-action).		
TYPE	RW		
WRITE LATENCY			

7	6	5	4	3	2	1	0
SCRATCH							
BITS	FIELD NAME	DESCRIPTION				TYPE	RESET
7:00	SCRATCH					RW	0x00

7.5.25 SCRATCH_REG_CLR

ADDRESS OFFSET	0x18		
PHYSICAL ADDRESS	0x18	INSTANCE	USB_SCUSB
DESCRIPTION	This register doesn't physically exist. It is the same as the scratch_reg with read/clear-only property (write '1' to clear a particular bit, a write '0' has no-action).		
TYPE	RW		
WRITE LATENCY			

7	6	5	4	3	2	1	0
SCRATCH							
BITS	FIELD NAME	DESCRIPTION				TYPE	RESET
7:00	SCRATCH					RW	0x00

TUSB1210-Q1

ZHCSCV8A – SEPTEMBER 2014 – REVISED OCTOBER 2014

www.ti.com.cn
7.5.26 VENDOR_SPECIFIC1

ADDRESS OFFSET		0x3D					
PHYSICAL ADDRESS		0x3D			INSTANCE		USB_SCUSB
DESCRIPTION		Power Control register .					
TYPE		RW					
WRITE LATENCY							
7	6	5	4	3	2	1	0
SPARE	MNTR_VUSBIN_OK_EN	ID_FLOAT_EN	ID_RES_EN	BVALID_FALL	BVALID_RISE	SPARE	ABNORMALSTRESS_EN
BITS	FIELD NAME	DESCRIPTION				TYPE	RESET
7	SPARE	Reserved. The link must never write a 1b to this bit.				RW	0
6	MNTR_VUSBIN_OK_EN	When set to 1, it enables RX CMDs for high to low or low to high transitions on MNTR_VUSBIN_OK. This bit is provided for debugging purposes.				RW	0
5	ID_FLOAT_EN	When set to 1, it enables RX CMDs for high to low or low to high transitions on ID_FLOAT. This bit is provided for debugging purposes.				RW	0
4	ID_RES_EN	When set to 1, it enables RX CMDs for high to low or low to high transitions on ID_RESA, ID_RESB and ID_RESC. This bit is provided for debugging purposes.				RW	0
3	BVALID_FALL	Enables RX CMDs for high to low transitions on BVALID. When BVALID changes from high to low, the USB TRANS will send an RX CMD to the link with the alt_int bit set to 1b. This bit is optional and is not necessary for OTG devices. This bit is provided for debugging purposes. Disabled by default.				RW	0
2	BVALID_RISE	Enables RX CMDs for low to high transitions on BVALID. When BVALID changes from low to high, the USB Trans will send an RX CMD to the link with the alt_int bit set to 1b. This bit is optional and is not necessary for OTG devices. This bit is provided for debugging purposes. Disabled by default.				RW	0
1	SPARE	Reserved. The link must never write a 1b to this bit.				RW	0
0	ABNORMALSTRESS_EN	When set to 1, it enables RX CMDs for low to high and high to low transitions on ABNORMALSTRESS. This bit is provided for debugging purposes.				RW	0

7.5.27 VENDOR_SPECIFIC1_SET

ADDRESS OFFSET	0x3E		
PHYSICAL ADDRESS	0x3E	INSTANCE	USB_SCUSB
DESCRIPTION	This register doesn't physically exist. It is the same as the func_ctrl register with read/set-only property (write '1' to set a particular bit, a write '0' has no-action).		
TYPE	RW		
WRITE LATEN CY			

7	6	5	4	3	2	1	0
SPARE	MNTR_VUSBIN_OK_EN	ID_FLOAT_EN	ID_RES_EN	BVALID_FALL	BVALID_RISE	SPARE	ABNORMALSTRESS_EN
BITS	FIELD NAME		DESCRIPTION			TYPE	RESET
7	SPARE					RW	0
6	MNTR_VUSBIN_OK_EN					RW	0
5	ID_FLOAT_EN					RW	0
4	ID_RES_EN					RW	0
3	BVALID_FALL					RW	0
2	BVALID_RISE					RW	0
1	SPARE					RW	0
0	ABNORMALSTRESS_EN					RW	0

TUSB1210-Q1

ZHCSCV8A – SEPTEMBER 2014 – REVISED OCTOBER 2014

www.ti.com.cn
7.5.28 VENDOR_SPECIFIC1_CLR

ADDRESS OFFSET		0x3F					
PHYSICAL ADDRESS		0x3F		INSTANCE		USB_SCUSB	
DESCRIPTION		This register doesn't physically exist. It is the same as the func_ctrl register with read/clear-only property (write '1' to clear a particular bit, a write '0' has no-action).					
TYPE		RW					
WRITE LATENCY							
7	6	5	4	3	2	1	0
SPARE	MNTR_VUSBIN_OK_EN	ID_FLOAT_EN	ID_RES_EN	BVALID_FALL	BVALID_RISE	SPARE	ABNORMALSTRESS_EN
BITS	FIELD NAME		DESCRIPTION			TYPE	RESET
7	SPARE					RW	0
6	MNTR_VUSBIN_OK_EN					RW	0
5	ID_FLOAT_EN					RW	0
4	ID_RES_EN					RW	0
3	BVALID_FALL					RW	0
2	BVALID_RISE					RW	0
1	SPARE					RW	0
0	ABNORMALSTRESS_EN					RW	0

7.5.29 VENDOR_SPECIFIC2

ADDRESS OFFSET		0x80					
PHYSICAL ADDRESS		0x80	INSTANCE		USB_SCUSB		
DESCRIPTION		Eye diagram programmability and DP/DM swap control .					
TYPE		RW					
WRITE LATENCY							
7	6	5	4	3	2	1	0
SPARE	DATAPOLARITY	ZHSDRV		IHSTX			
BITS	FIELD NAME	DESCRIPTION				TYPE	RESET
7	SPARE					RW	0
6	DATAPOLARITY	Control data polarity on dp/dm				RW	1
5:04	ZHSDRV	High speed output impedance configuration for eye diagram tuning : 00 45.455 Ω 01 43.779 Ω 10 42.793 Ω 11 42.411 Ω				RW	0x0
3:00	IHSTX	High speed output drive strength configuration for eye diagram tuning : 0000 17.928 mA 0001 18.117 mA 0010 18.306 mA 0011 18.495 mA 0100 18.683 mA 0101 18.872 mA 0110 19.061 mA 0111 19.249 mA 1000 19.438 mA 1001 19.627 mA 1010 19.816 mA 1011 20.004 mA 1100 20.193 mA 1101 20.382 mA 1110 20.570 mA 1111 20.759 mA IHSTX[0] is also the AC BOOST enable IHSTX[0] = 0 à AC BOOST is disabled IHSTX[0] = 1 à AC BOOST is enabled				RW	0x1

TUSB1210-Q1

ZHCSCV8A – SEPTEMBER 2014 – REVISED OCTOBER 2014

www.ti.com.cn
7.5.30 VENDOR_SPECIFIC2_SET

ADDRESS OFFSET		0x81					
PHYSICAL ADDRESS		0x81		INSTANCE		USB_SCUSB	
DESCRIPTION		This register doesn't physically exist. It is the same as the VENDOR_SPECIFIC1 register with read/set-only property (write '1' to set a particular bit, a write '0' has no-action).					
TYPE		RW					
WRITE LATENCY							
7	6	5	4	3	2	1	0
SPARE	DATAPOLARITY	ZHSDRV		IHSTX			

BITS	FIELD NAME	DESCRIPTION	TYPE	RESET
7	SPARE		RW	0
6	DATAPOLARITY		RW	1
5:04	ZHSDRV		RW	0x0
3:00	IHSTX		RW	0x1

7.5.31 VENDOR_SPECIFIC2_CLR

ADDRESS OFFSET		0x82					
PHYSICAL ADDRESS		0x82		INSTANCE		USB_SCUSB	
DESCRIPTION		This register doesn't physically exist. It is the same as the VENDOR_SPECIFIC1 register with read/clear-only property (write '1' to clear a particular bit, a write '0' has no-action).					
TYPE		RW					
WRITE LATENCY							
7	6	5	4	3	2	1	0
SPARE	DATAPOLARITY	ZHSDRV		IHSTX			

BITS	FIELD NAME	DESCRIPTION	TYPE	RESET
7	SPARE		RW	0
6	DATAPOLARITY		RW	1
5:04	ZHSDRV		RW	0x0
3:00	IHSTX		RW	0x1

7.5.32 VENDOR_SPECIFIC1_STS

ADDRESS OFFSET		0x83					
PHYSICAL ADDRESS		0x83		INSTANCE		USB_SCUSB	
DESCRIPTION		Indicates the current value of the interrupt source signal.					
TYPE		R					
WRITE LATEN CY							
7	6	5	4	3	2	1	0
Reserved	MNTR_VUSBIN_OK_STS	ABNORMALSTRESS_STS	ID_FLOAT_STS	ID_RESC_STS	ID_RESB_STS	ID_RESA_STS	BVALID_STS

BITS	FIELD NAME	DESCRIPTION	TYPE	RESET
7	Reserved		R	0
6	MNTR_VUSBIN_OK_STS	Current value of MNTR_VUSBIN_OK output	R	0
5	ABNORMALSTRESS_STS	Current value of ABNORMALSTRESS output	R	0
4	ID_FLOAT_STS	Current value of ID_FLOAT output	R	0
3	ID_RESC_STS	Current value of ID_RESC output	R	0
2	ID_RESB_STS	Current value of ID_RESB output	R	0
1	ID_RESA_STS	Current value of ID_RESA output	R	0
0	BVALID_STS	Current value of VB_SESS_VLD output	R	0

TUSB1210-Q1

ZHCSCV8A – SEPTEMBER 2014 – REVISED OCTOBER 2014

www.ti.com.cn
7.5.33 VENDOR_SPECIFIC1_LATCH

ADDRESS OFFSET		0x84						
PHYSICAL ADDRESS		0x84		INSTANCE		USB_SCUSB		
DESCRIPTION		<p>These bits are set by the PHY when an unmasked change occurs on the corresponding internal signal. The PHY will automatically clear all bits when the Link reads this register, or when Low Power Mode is entered. The PHY also clears this register when Serial mode is entered regardless of the value of ClockSuspendM.</p> <p>The PHY follows the rules defined in Table 26 of the ULPI spec for setting any latch register bit.</p>						
TYPE		R						
WRITE LATENCY								
7		6	5	4	3	2	1	0
Reserved		MNTR_VUSBIN_OK_LATCH	ABNORMALSTRESS_LATCH	ID_FLOAT_LATCH	ID_RESC_LATCH	ID_RESB_LATCH	ID_RESA_LATCH	BVALID_LATCH

BITS	FIELD NAME	DESCRIPTION	TYPE	RESET
7	Reserved		R	0
6	MNTR_VUSBIN_OK_LATCH	Set to 1 when an unmasked event occurs on MNTR_VUSBIN_OK_LATCH. Clear on read register.	R	0
5	ABNORMALSTRESS_LATCH	Set to 1 when an unmasked event occurs on ABNORMALSTRESS. Clear on read register.	R	0
4	ID_FLOAT_LATCH	Set to 1 when an unmasked event occurs on ID_FLOAT. Clear on read register.	R	0
3	ID_RESC_LATCH	Set to 1 when an unmasked event occurs on ID_RESC. Clear on read register.	R	0
2	ID_RESB_LATCH	Set to 1 when an unmasked event occurs on ID_RESB. Clear on read register.	R	0
1	ID_RESA_LATCH	Set to 1 when an unmasked event occurs on ID_RESA. Clear on read register.	R	0
0	BVALID_LATCH	Set to 1 when an unmasked event occurs on VB_SESS_VLD. Clear on read register.	R	0

7.5.34 VENDOR_SPECIFIC3

ADDRESS OFFSET		0x85					
PHYSICAL ADDRESS		0x85	INSTANCE		USB_SCUSB		
DESCRIPTION							
TYPE		RW					
WRITE LATENCY							
7	6	5	4	3	2	1	0
RESERVED	SOF_EN	CPEN_OD	CPEN_ODOS	IDGND_DRV	VUSB3V3_VSEL		
BITS	FIELD NAME	DESCRIPTION				TYPE	RESET
7	Reserved					RW	0
6	SOF_EN	<p>0: HS USB SOF detector disabled.</p> <p>1: Enable HS USB SOF detection when PHY is set in device mode. SOF are output on CPEN pin. HS USB SOF (start-of-frame) output clock is available on CPEN pin when this bit is set. HS USB SOF packet rate is 8 kHz.</p> <p>This bit is provided for debugging purpose only. It must never be written to '1' in functional mode</p>				RW	0
5	CPEN_OD	<p>This bit has no effect when CPEN_ODOS = '0', else :</p> <p>0: CPEN pad is in OS (Open Source) mode. In this case CPEN pin has an internal NMOS driver, and will be active LOW. Externally there should be a pullup resistor on CPEN (min 1kohm) to a supply voltage (max 3.6V).</p> <p>1: CPEN pad is in OD (Open Drain) mode In this case CPEN pin has an internal PMOS driver, and will be active HIGH. Externally there should be a pull-down resistor on CPEN (min 1 kΩ to GND.</p>				RW	0
4	CPEN_ODOS	<p>Mode selection bit for CPEN pin.</p> <p>0 : CPEN pad is in CMOS mode</p> <p>1: CPEN pad is in OD (Open Drain) or OS (Open Source) mode (controlled by CPEN_OD bit)</p>				RW	0
3	IDGND_DRV	Drives ID pin to ground				RW	0x0
2:00	VUSB3V3_VSEL	<p>000 VRUSB3P1V = 2.5 V</p> <p>001 VRUSB3P1V = 2.75 V</p> <p>010 VRUSB3P1V = 3.0 V</p> <p>011 VRUSB3P1V = 3.10 V (default)</p> <p>100 VRUSB3P1V = 3.20 V</p> <p>101 VRUSB3P1V = 3.30 V</p> <p>110 VRUSB3P1V = 3.40 V</p> <p>111 VRUSB3P1V = 3.50 V</p>				RW	0x3

TUSB1210-Q1

ZHCSCV8A – SEPTEMBER 2014 – REVISED OCTOBER 2014

www.ti.com.cn
7.5.35 VENDOR_SPECIFIC3_SET

ADDRESS OFFSET		0x86					
PHYSICAL ADDRESS		0x86		INSTANCE		USB_SCUSB	
DESCRIPTION							
TYPE		RW					
WRITE LATENCY							
7	6	5	4	3	2	1	0
RESERVED	SOF_EN	CPEN_OD	CPEN_ODOS	IDGND_DRV	VUSB3V3_VSEL		
BITS	FIELD NAME		DESCRIPTION			TYPE	RESET
7	Reserved					RW	0
6	SOF_EN					RW	0
5	CPEN_OD					RW	0
4	CPEN_ODOS					RW	0
3	IDGND_DRV					RW	0x0
2:00	VUSB3V3_VSEL					RW	0x3

7.5.36 VENDOR_SPECIFIC3_CLR

ADDRESS OFFSET		0x87					
PHYSICAL ADDRESS		0x87		INSTANCE		USB_SCUSB	
DESCRIPTION							
TYPE		RW					
WRITE LATENCY							
7	6	5	4	3	2	1	0
RESERVED	SOF_EN	CPEN_OD	CPEN_ODOS	IDGND_DRV	VUSB3V3_VSEL		
BITS	FIELD NAME		DESCRIPTION			TYPE	RESET
7	Reserved					RW	0
6	SOF_EN					RW	0
5	CPEN_OD					RW	0
4	CPEN_ODOS					RW	0
3	IDGND_DRV					RW	0x0
2:00	VUSB3V3_VSEL					RW	0x3

8 Application and Implementation

NOTE

Information in the following applications sections is not part of the TI component specification, and TI does not warrant its accuracy or completeness. TI's customers are responsible for determining suitability of components for their purposes. Customers should validate and test their design implementation to confirm system functionality.

8.1 Application Information

Figure 5 shows the suggested application diagram (Host or OTG, ULPI input-clock mode).

8.2 Typical Application

8.2.1 Host or OTG, ULPI Input Clock Mode Application

Figure 5 shows a suggested application diagram for TUSB1210-Q1 in the case of ULPI input-clock mode (60 MHz ULPI clock is provided by link processor), in Host or OTG application. Note this is just one example, it is of course possible to operate as HOST or OTG while also in ULPI output-clock mode.

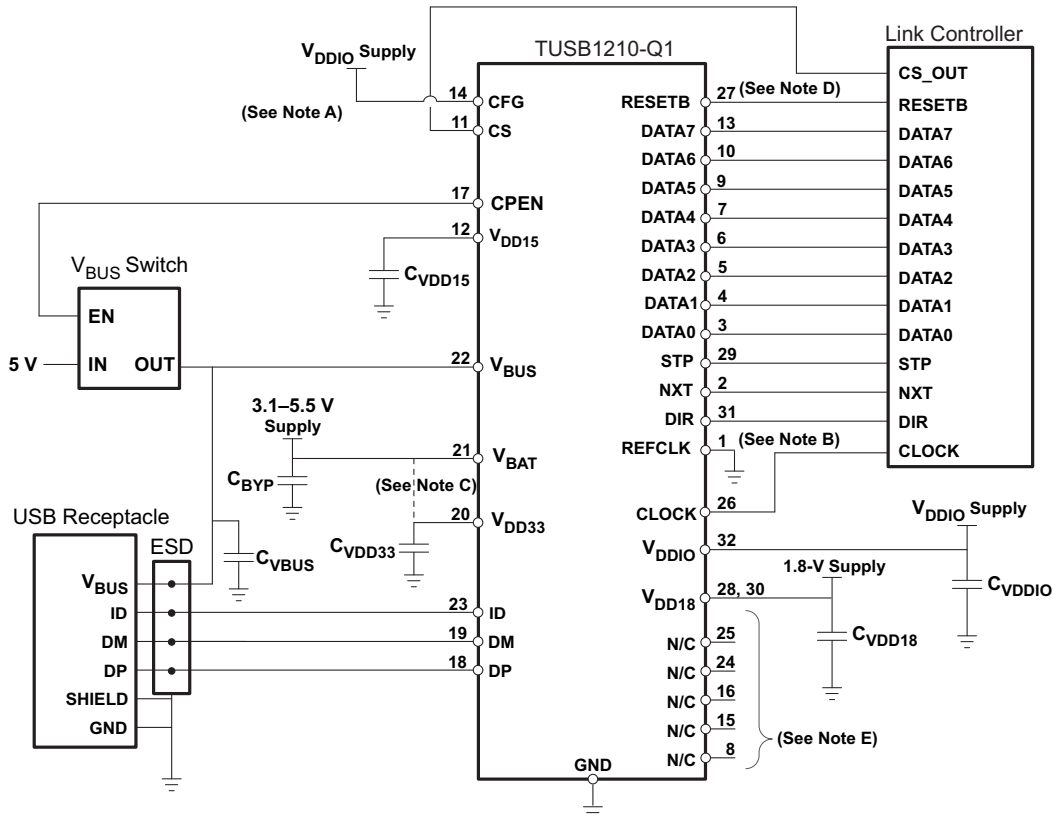

- A. Pin 11 (CS) : can be tied high to V_{IO} if CS_OUT pin unavailable; Pin 14 (CFG) : tie-high is Don't Care since ULPI clock is used in input mode
- B. Pin 1 (REFCLK) : must be tied low
- C. Ext 3 V supply supported
- D. Pin 27 (RESETB) can be tied to V_{DDIO} if unused.
- E. Pins labeled N/C (no-connect) are truly no-connect, and can be tied or left floating.

Figure 5. Host or OTG, ULPI Input Clock Mode Application Diagram

Typical Application (continued)

8.2.1.1 Design Requirements

Table 9. Design Parameters

DESIGN PARAMETER	EXAMPLE VALUE
V_{BAT}	3.3 V
V_{DDIO}	1.8 V
V_{BUS}	5.0 V
USB Support	HS, FS, LS
USB On the Go (OTG)	Yes
Clock Sources	60 MHz Clock

8.2.1.2 Detailed Design Procedure

Connect the TUSB1210 device as is shown in [Figure 5](#).

Follow the Board Guidelines of the Application Report, [SWCA124](#).

8.2.1.2.1 Unused Pins Connection

- **VBUS:** Input. Recommended to tie to GND if unused. However leaving V_{BUS} floating is also acceptable since internally there is an 80 k Ω resistance to ground.
- **REFCLK:** Input. If REFCLK is unused, and 60 MHz clock is provided by MODEM (60 MHz should be connected to CLOCK pin in this case) then tie REFCLK to GND.
- **CFG:** Tie to GND if REFCLK is 19.2MHz, or tie to V_{DDIO} if REFCLK is 26 MHz. Tie to either GND or V_{DDIO} (doesn't matter which) if REFCLK not used (i.e., ULPI input clock configuration).

8.2.1.3 Application Curve

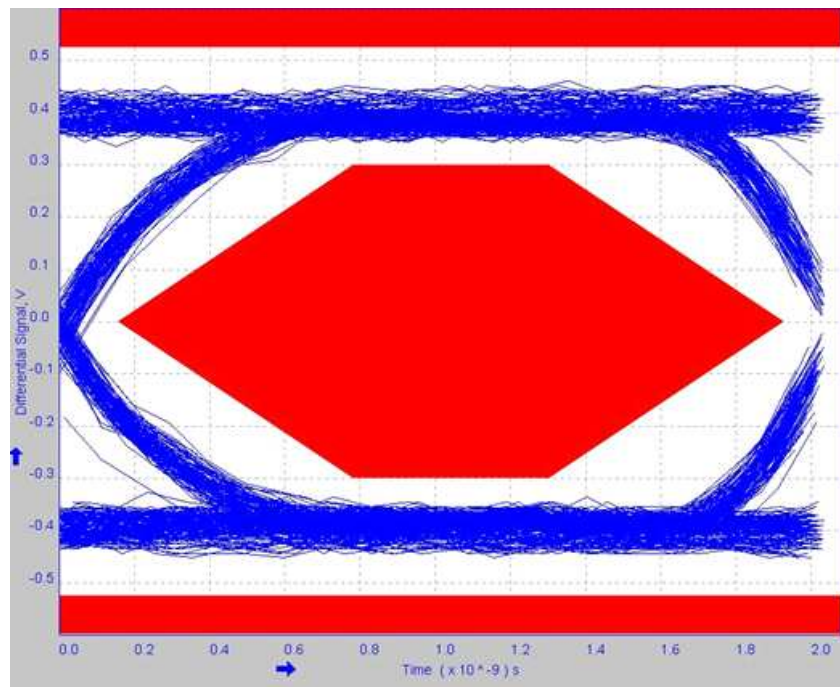
Figure 6. High-Speed Eye Diagram

8.2.2 Device, ULPI Output Clock Mode Application

Figure 7 shows a suggested application diagram for TUSB1210-Q1 in the case of ULPI output clock mode (60 MHz ULPI clock is provided by TUSB1210-Q1, while link processor or another external circuit provides REFCLK), in Device mode application. Note this is just one example, it is of course possible to operate as Device while also in ULPI input-clock mode. Refer also to Figure 5.

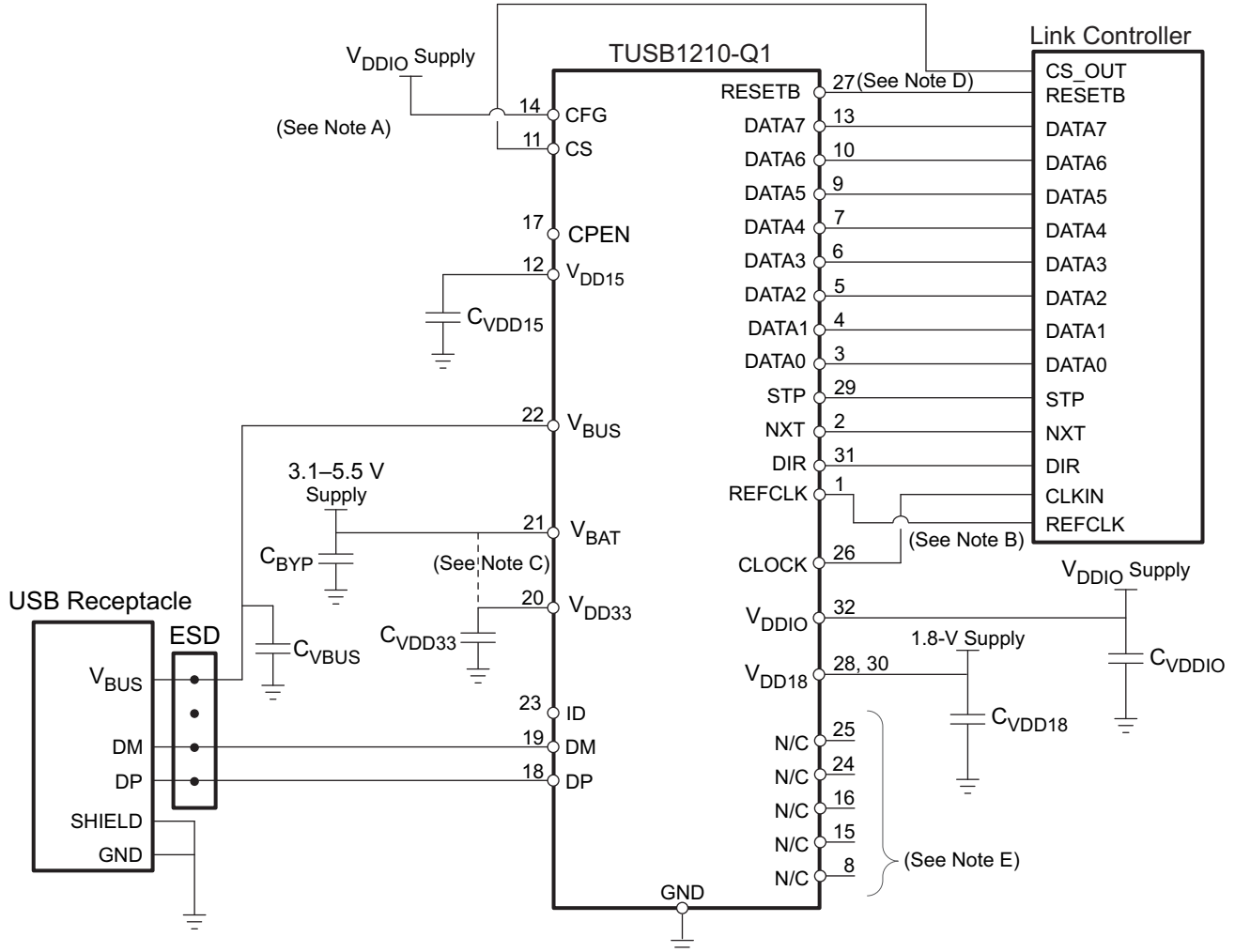

- A. Pin 11 (CS) : can be tied high to V_{IO} if CS_OUT pin unavailable; Pin 14 (CFG) : Tied to V_{DDIO} for 26MHz REFCLK mode here, tie to GND for 19.2MHz mode.
- B. Pin 1 (REFCLK) : connect to external 3.3V square-wave reference clock
- C. Ext 3 V supply supported
- D. Pin 27 (RESETB) can be tied to V_{DDIO} if unused.
- E. Pins labeled N/C (no-connect) are truly no-connect, and can be tied or left floating.

Figure 7. Device, ULPI Output Clock Mode Application Diagram

8.2.2.1 Design Requirements

Table 10. Design Parameters

DESIGN PARAMETER	EXAMPLE VALUE
V_{BAT}	3.3 V
V_{DDIO}	1.8 V
V_{BUS}	5.0 V
USB Support	HS, FS, LS
Clock Sources	26 MHz or 19.2 MHz Oscillator

8.2.2.2 Detailed Design Procedure

Connect the TUSB1210 device as is shown in [Figure 7](#).

Follow the Board Guidelines of the Application Report, [SWCA124](#).

8.2.2.2.1 Unused Pins Connection

- **ID:** Input. Leave floating if unused or TUSB1210-Q1 is Device mode only. Tie to GND through RID < 1 kOhm if Host mode.
- **REFCLK:** Input. If REFCLK is unused, and 60 MHz clock is provided by MODEM (60 MHz should be connected to CLOCK pin in this case) then tie REFCLK to GND.
- **CFG:** Tie to GND if REFCLK is 19.2MHz, or tie to V_{DDIO} if REFCLK is 26 MHz. Tie to either GND or V_{DDIO} (doesn't matter which) if REFCLK not used (i.e., ULPI input clock configuration).

8.2.2.3 Application Curve

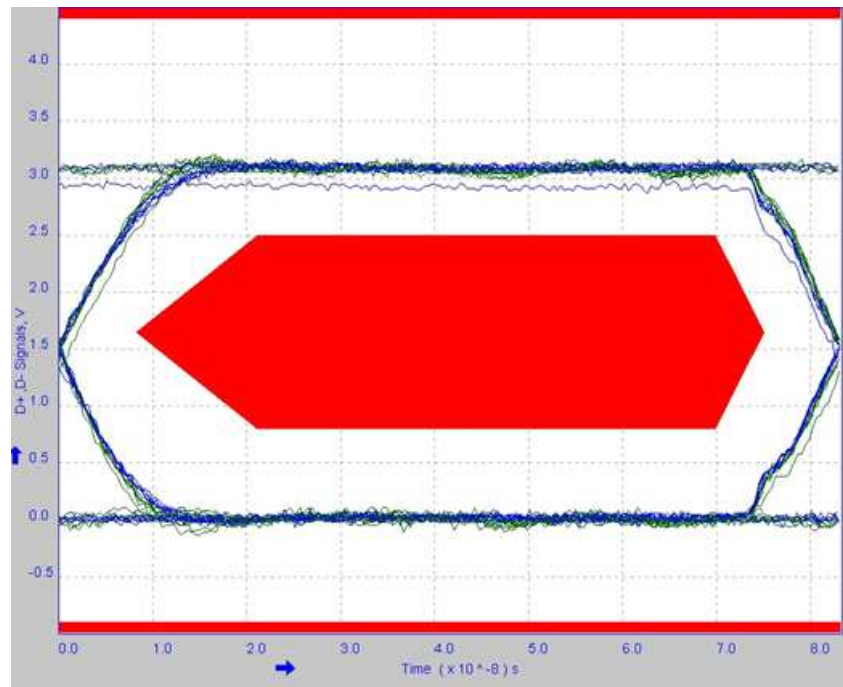
Figure 8. Full-Speed Eye Diagram

8.3 External Components

Table 11. TUSB1210-Q1 External Components

FUNCTION	COMPONENT	REFERENCE	VALUE	NOTE	LINK
V _{DDIO}	Capacitor	CVDDIO	100 nF	Suggested value, application dependent	Figure 5
V _{DD33}	Capacitor	CVDD33	2.2 μF	Range: [0.45 μF : 6.5 μF] , ESR = [0 : 600 mΩ] for f> 10 kHz	Figure 5
V _{DD15}	Capacitor	CVDD15	2.2 μF	Range: [0.45 μF : 6.5 μF] , ESR = [0 : 600 mΩ] for f> 10 kHz	Figure 5
V _{DD18}	Capacitor	Ext 1.8V supply	100 nF	Suggested value, application dependent	Figure 5
		CVDD18			
V _{BAT}	Capacitor	CBYP	100 nF ⁽¹⁾	Range: [0.45 μF : 6.5 μF] , ESR = [0 : 600 mΩ] for f> 10 kHz	Figure 5
V _{BUS}	Capacitor	CVBUS	See Table 12	Place close to USB connector	Figure 5

(1) Recommended value but 2.2 uF may be sufficient in some applications

Table 12. TUSB1210-Q1 V_{BUS} Capacitors

FUNCTION	COMPONENT	REFERENCE	VALUE	NOTE	LINK
VBUS - HOST	Capacitor	CVBUS	>120 μF		Figure 5
VBUS – DEVICE	Capacitor	CVBUS	4.7 μF	Range: 1.0 μF to 10.0 μF	Figure 5
VBUS - OTG	Capacitor	CVBUS	4.7 μF	Range: 1.0 μF to 6.5 μF	Figure 5

9 Power Supply Recommendations

V_{BUS} , and V_{BAT} , and V_{DDIO} , are needed for power the TUSB1210-Q1. Recommended operation is for V_{BAT} to be present before V_{DDIO} . Applying V_{DDIO} before V_{BAT} to TUSB1210 is not recommended as there is a diode from V_{DDIO} to V_{BAT} which will be forward biased when V_{DDIO} is present but V_{BAT} is not present. TUSB1210-Q1 does not strictly require V_{BUS} to function.

9.1 TUSB1210 Power Supply

- The V_{DDIO} pins of the TUSB1210-Q1 supply 1.8 V (nominal) power to the core of the TUSB1210-Q1. This power rail can be isolated from all other power rails by a ferrite bead to reduce noise.
- The V_{BAT} pin of the TUSB1210-Q1 supply 3.3 V (nominal) power rail to the TUSB1210-Q1. This power rail can be isolated from all other power rails by a ferrite bead to reduce noise.
- The V_{BUS} pin of the TUSB1210-Q1 supply 5.0 V (nominal) power rail to the TUSB1210-Q1. This pin is normally connected to the V_{BUS} pin of the USB connector.
- The V_{BUS} pin of the TUSB1210-Q1 supply 5.0 V (nominal) power rail to the TUSB1210-Q1. This pin is normally connected to the V_{BUS} pin of the USB connector.

9.2 Ground

It is recommended that almost one board ground plane be used in the design. This provides the best image plane for signal traces running above the plane. An earth or chassis ground is implemented only near the USB port connectors on a different plane for EMI and ESD purposes.

9.3 Power Providers

Table 13 is a summary of TUSB1210-Q1 power providers.

Table 13. Power Providers⁽¹⁾

NAME	USAGE	TYPE	TYPICAL VOLTAGE (V)	MAXIMUM CURRENT (mA)
V_{DD15}	Internal	LDO	1.5	50
V_{DD18}	External	LDO	1.8	30
V_{DD33}	Internal	LDO	3.1	15

(1) V_{DD33} may be supplied externally, or by shorting the V_{DD33} pin to V_{BAT} pin provided V_{BAT} min is in range [3.2 V : 3.6 V]. Note that the V_{DD33} LDO will always power-on when the chip is enabled, irrespective of whether V_{DD33} is supplied externally or not. In the case the V_{DD33} pin is not supplied externally in the application, the electrical specs for this LDO are provided below.

9.4 Power Modules

9.4.1 V_{DD33} Regulator

The V_{DD33} internal LDO regulator powers the USB PHY, charger detection, and OTG functions of the USB subchip inside TUSB1210-Q1. [Power Characteristics](#) describes the regulator characteristics.

V_{DD33} regulator takes its power from V_{BAT} .

Since the USB2.0 standard requires data lines to be biased with pullups biased from a supply greater than 3 V, and since V_{DD33} regulator has an inherent voltage drop from its input, V_{BAT} , to its regulated output, TUSB1210-Q1 will not meet USB 2.0 Standard if operated from a battery whose voltage is lower than 3.3 V.

9.4.2 V_{DD18} Supply

The V_{DD18} supply is powered externally at the V_{DD18} pin. See [Table 11](#) for external components.

9.4.3 V_{DD15} Regulator

The V_{DD15} internal LDO regulator powers the USB subchip inside TUSB1210-Q1. [Power Characteristics](#) describes the regulator characteristics.

9.5 Power Consumption

Table 14 describes the power consumption depending on the use cases.

NOTE

The typical power consumption is obtained in the nominal operating conditions and with the TUSB1210-Q1 standalone.

Table 14. Power Consumption

MODE	CONDITIONS	SUPPLY	TYPICAL CONSUMPTION	UNIT
OFF Mode	$V_{BAT} = 3.6\text{ V}$, $V_{DDIO} = 1.8\text{ V}$, $V_{DD18} = 1.8\text{ V}$, $CS = 0\text{ V}$	I_{VBAT}	8	μA
		I_{VDDIO}	3	
		I_{VDD18}	5	
		I_{TOTAL}	16	
Suspend Mode	$V_{BUS} = 5\text{ V}$, $V_{BAT} = 3.6\text{ V}$, $V_{DDIO} = 1.8\text{ V}$, No clock	I_{VBAT}	204	μA
		I_{VDDIO}	3	
		I_{VDD18}	3	
		I_{TOTAL}	210	
HS USB Operation (Synchronous Mode)	$V_{BAT} = 3.6\text{ V}$, $V_{DDIO} = 1.8\text{ V}$, $V_{DD18} = 1.8\text{ V}$, active USB transfer	I_{VBAT}	24.6	mA
		I_{VDDIO}	1.89	
		I_{VDD18}	21.5	
		I_{TOTAL}	48	
FS USB Operation (Synchronous Mode)	$V_{BAT} = 3.6\text{ V}$, $V_{DDIO} = 1.8\text{ V}$, active USB transfer	I_{VBAT}	25.8	mA
		I_{VDDIO}	1.81	
		I_{VDD18}	4.06	
		I_{TOTAL}	31.7	
Reset Mode	$RESETB = 0\text{ V}$, $V_{BUS} = 5\text{ V}$, $V_{BAT} = 3.6\text{ V}$, $V_{DDIO} = 1.8\text{ V}$, No clock	I_{VBAT}	237	μA
		I_{VDDIO}	3	
		I_{VDD18}	3	
		I_{TOTAL}	243	

10 Layout

10.1 Layout Guidelines

- The V_{DDIO} pins of the TUSB1210-Q1 supply 1.8-V (nominal) power to the core of the TUSB1210-Q1. This power rail can be isolated from all other power rails by a ferrite bead to reduce noise.
- The V_{BAT} pin of the TUSB1210-Q1 supply 3.3-V (nominal) power rail to the TUSB1210-Q1. This power rail can be isolated from all other power rails by a ferrite bead to reduce noise.
- The V_{BUS} pin of the TUSB1210-Q1 supply 5-V (nominal) power rail to the TUSB1210-Q1. This pin is normally connected to the V_{BUS} pin of the USB connector.
- All power rails require 0.1 μF decoupling capacitors for stability and noise immunity. The smaller decoupling capacitors should be placed as close to the TUSB1210-Q1 power pins as possible with an optimal grouping of two of differing values per pin.

10.2 Layout Example

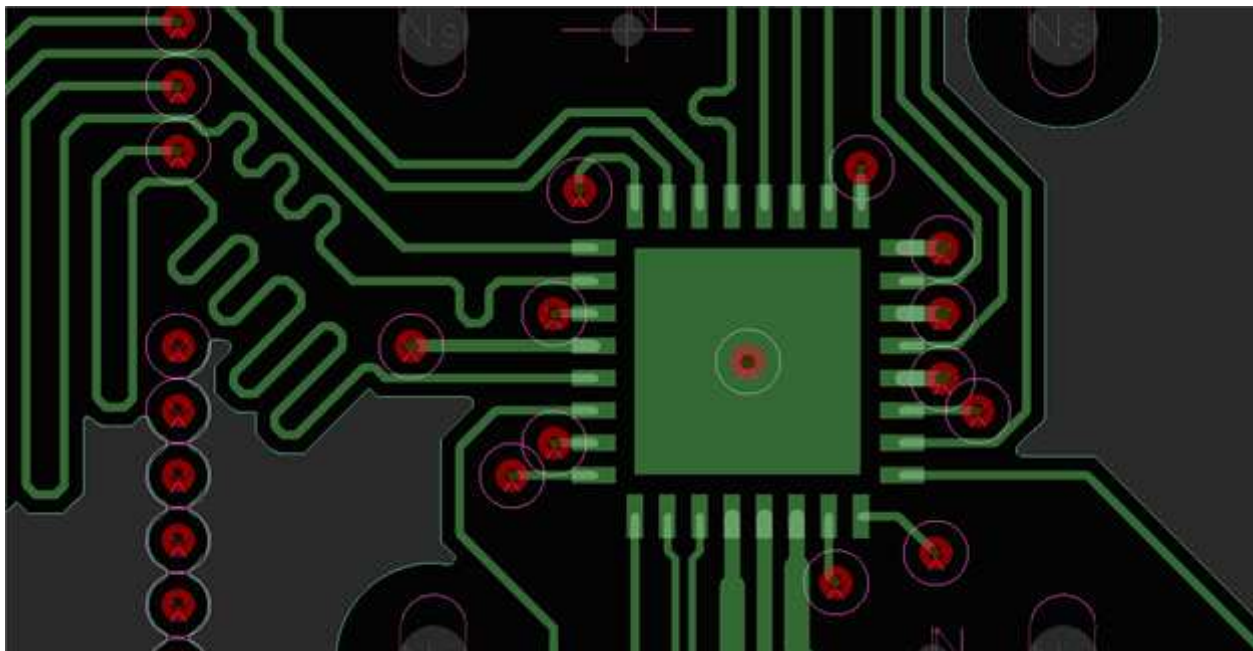

Figure 9. TUSB1210-Q1 Layout Example

11 器件和文档支持

11.1 文档支持

SLZ066 芯片勘误表。描述了 TUSB1210-Q1 功能技术规格的已知例外情况。

11.2 社区资源

下列链接提供到 TI 社区资源的连接。链接的内容由各个分销商“按照原样”提供。这些内容并不构成 TI 技术规范 and 标准且不一定反映 TI 的观点；请见 TI 的[使用条款](#)。

TI E2E™ 在线社区 [TI 工程师对工程师 \(E2E\) 社区](#)。此社区的创建目的是为了促进工程师之间协作。在 e2e.ti.com 中，您可以咨询问题、共享知识、探索思路，在同领域工程师的帮助下解决问题。

德州仪器 (TI) 嵌入式处理器维基网站 [德州仪器 \(TI\) 嵌入式处理器维基网站](#)。此网站的建立是为了帮助开发人员从德州仪器 (TI) 的嵌入式处理器入门并且也为了促进与这些器件相关的硬件和软件的总体知识的创新和增长。

11.3 商标

E2E is a trademark of Texas Instruments.

All other trademarks are the property of their respective owners.

11.4 静电放电警告



ESD 可能会损坏该集成电路。德州仪器 (TI) 建议通过适当的预防措施处理所有集成电路。如果不遵守正确的处理措施和安装程序，可能会损坏集成电路。

ESD 的损坏小至导致微小的性能降级，大至整个器件故障。精密的集成电路可能更容易受到损坏，这是因为非常细微的参数更改都可能会导致器件与其发布的规格不相符。

11.5 术语表

11.5.1 术语表

SLY022 — TI 术语表。

这份术语表列出并解释术语、首字母缩略词和定义。

12 机械封装和可订购信息

12.1 Via Channel

T 封装采用 Via Channel 技术进行了特别设计。这使得 PCB 设计中能够采用 0.65mm 间距封装，实现比正常尺寸更大的 PCB 过孔和布线，从而减小 PCB 信号层数，并大幅降低 PCB 成本。由于 Via Channel BGA 技术提升了分层效率，因此该器件允许仅在两个信号层（共四层）中进行 PCB 布线。

利用 [所用封装] 封装中实施的 Via Channel 技术可构建基于 [所用器件] 的产品，该产品采用 4 层 PCB 设计，但这可能达不到系统性能目标要求。因此，产品设计期间必须对采用 4 层 PCB 设计的系统的性能进行评估。

12.2 封装信息

以下页中包括机械封装和可订购信息。 这些信息是针对指定器件可提供的最新数据。 这些数据会在无通知且不对本文档进行修订的情况下发生改变。 欲获得该数据表的浏览器版本，请查阅左侧的导航栏。

重要声明

德州仪器(TI)及其下属子公司有权根据 JESD46 最新标准,对所提供的产品和服务进行更正、修改、增强、改进或其它更改,并有权根据 JESD48 最新标准中止提供任何产品和服务。客户在下订单前应获取最新的相关信息,并验证这些信息是否完整且是最新的。所有产品的销售都遵循在订单确认时所提供的TI 销售条款与条件。

TI 保证其所销售的组件的性能符合产品销售时 TI 半导体产品销售条件与条款的适用规范。仅在 TI 保证的范围内,且 TI 认为有必要时才会使用测试或其它质量控制技术。除非适用法律做出了硬性规定,否则没有必要对每种组件的所有参数进行测试。

TI 对应用帮助或客户产品设计不承担任何义务。客户应对其使用 TI 组件的产品和应用自行负责。为尽量减小与客户产品和应用相关的风险,客户应提供充分的设计与操作安全措施。

TI 不对任何 TI 专利权、版权、屏蔽作品权或其它与使用了 TI 组件或服务的组合设备、机器或流程相关的 TI 知识产权中授予的直接或隐含权限作出任何保证或解释。TI 所发布的与第三方产品或服务有关的信息,不能构成从 TI 获得使用这些产品或服务的许可、授权、或认可。使用此类信息可能需要获得第三方的专利权或其它知识产权方面的许可,或是 TI 的专利权或其它知识产权方面的许可。

对于 TI 的产品手册或数据表中 TI 信息的重要部分,仅在没有对内容进行任何篡改且带有相关授权、条件、限制和声明的情况下才允许进行复制。TI 对此类篡改过的文件不承担任何责任或义务。复制第三方的信息可能需要服从额外的限制条件。

在转售 TI 组件或服务时,如果对该组件或服务参数的陈述与 TI 标明的参数相比存在差异或虚假成分,则会失去相关 TI 组件或服务的所有明示或暗示授权,且这是不正当的、欺诈性商业行为。TI 对任何此类虚假陈述均不承担任何责任或义务。

客户认可并同意,尽管任何应用相关信息或支持仍可能由 TI 提供,但他们将独立负责满足与其产品及其在应用中使用的 TI 产品相关的所有法律、法规和安全相关要求。客户声明并同意,他们具备制定与实施安全措施所需的全部专业技术和知识,可预见故障的危险后果、监测故障及其后果、降低有可能造成人身伤害的故障的发生机率并采取适当的补救措施。客户将全额赔偿因在此类安全关键应用中使用任何 TI 组件而对 TI 及其代理造成的任何损失。

在某些场合中,为了推进安全相关应用有可能对 TI 组件进行特别的促销。TI 的目标是利用此类组件帮助客户设计和创立其特有的可满足适用的功能安全性标准和要求的终端产品解决方案。尽管如此,此类组件仍然服从这些条款。

TI 组件未获得用于 FDA Class III (或类似的生命攸关医疗设备)的授权许可,除非各方授权官员已经达成了专门管控此类使用的特别协议。

只有那些 TI 特别注明属于军用等级或“增强型塑料”的 TI 组件才是设计或专门用于军事/航空应用或环境的。购买者认可并同意,对并非指定面向军事或航空航天用途的 TI 组件进行军事或航空航天方面的应用,其风险由客户单独承担,并且由客户独立负责满足与此类使用相关的所有法律和法规要求。

TI 已明确指定符合 ISO/TS16949 要求的产品,这些产品主要用于汽车。在任何情况下,因使用非指定产品而无法达到 ISO/TS16949 要求, TI 不承担任何责任。

	产品		应用
数字音频	www.ti.com.cn/audio	通信与电信	www.ti.com.cn/telecom
放大器和线性器件	www.ti.com.cn/amplifiers	计算机及周边	www.ti.com.cn/computer
数据转换器	www.ti.com.cn/dataconverters	消费电子	www.ti.com.cn/consumer-apps
DLP® 产品	www.dlp.com	能源	www.ti.com.cn/energy
DSP - 数字信号处理器	www.ti.com.cn/dsp	工业应用	www.ti.com.cn/industrial
时钟和计时器	www.ti.com.cn/clockandtimers	医疗电子	www.ti.com.cn/medical
接口	www.ti.com.cn/interface	安防应用	www.ti.com.cn/security
逻辑	www.ti.com.cn/logic	汽车电子	www.ti.com.cn/automotive
电源管理	www.ti.com.cn/power	视频和影像	www.ti.com.cn/video
微控制器 (MCU)	www.ti.com.cn/microcontrollers		
RFID 系统	www.ti.com.cn/rfidsys		
OMAP应用处理器	www.ti.com/omap		
无线连通性	www.ti.com.cn/wirelessconnectivity	德州仪器在线技术支持社区	www.deyisupport.com

邮寄地址: 上海市浦东新区世纪大道1568号, 中建大厦32楼邮政编码: 200122
Copyright © 2014, 德州仪器半导体技术(上海)有限公司

PACKAGING INFORMATION

Orderable Device	Status (1)	Package Type	Package Drawing	Pins	Package Qty	Eco Plan (2)	Lead finish/ Ball material (6)	MSL Peak Temp (3)	Op Temp (°C)	Device Marking (4/5)	Samples
TUSB1210BRHBRQ1	ACTIVE	VQFN	RHB	32	3000	RoHS & Green	NIPDAU	Level-2-260C-1 YEAR	-40 to 85	T1210Q1	Samples
TUSB1210BRHBTQ1	ACTIVE	VQFN	RHB	32	250	RoHS & Green	NIPDAU	Level-2-260C-1 YEAR	-40 to 85	T1210Q1	Samples

(1) The marketing status values are defined as follows:

ACTIVE: Product device recommended for new designs.

LIFEBUY: TI has announced that the device will be discontinued, and a lifetime-buy period is in effect.

NRND: Not recommended for new designs. Device is in production to support existing customers, but TI does not recommend using this part in a new design.

PREVIEW: Device has been announced but is not in production. Samples may or may not be available.

OBSOLETE: TI has discontinued the production of the device.

(2) **RoHS:** TI defines "RoHS" to mean semiconductor products that are compliant with the current EU RoHS requirements for all 10 RoHS substances, including the requirement that RoHS substance do not exceed 0.1% by weight in homogeneous materials. Where designed to be soldered at high temperatures, "RoHS" products are suitable for use in specified lead-free processes. TI may reference these types of products as "Pb-Free".

RoHS Exempt: TI defines "RoHS Exempt" to mean products that contain lead but are compliant with EU RoHS pursuant to a specific EU RoHS exemption.

Green: TI defines "Green" to mean the content of Chlorine (Cl) and Bromine (Br) based flame retardants meet JS709B low halogen requirements of <=1000ppm threshold. Antimony trioxide based flame retardants must also meet the <=1000ppm threshold requirement.

(3) MSL, Peak Temp. - The Moisture Sensitivity Level rating according to the JEDEC industry standard classifications, and peak solder temperature.

(4) There may be additional marking, which relates to the logo, the lot trace code information, or the environmental category on the device.

(5) Multiple Device Markings will be inside parentheses. Only one Device Marking contained in parentheses and separated by a "~" will appear on a device. If a line is indented then it is a continuation of the previous line and the two combined represent the entire Device Marking for that device.

(6) Lead finish/Ball material - Orderable Devices may have multiple material finish options. Finish options are separated by a vertical ruled line. Lead finish/Ball material values may wrap to two lines if the finish value exceeds the maximum column width.

Important Information and Disclaimer:The information provided on this page represents TI's knowledge and belief as of the date that it is provided. TI bases its knowledge and belief on information provided by third parties, and makes no representation or warranty as to the accuracy of such information. Efforts are underway to better integrate information from third parties. TI has taken and continues to take reasonable steps to provide representative and accurate information but may not have conducted destructive testing or chemical analysis on incoming materials and chemicals. TI and TI suppliers consider certain information to be proprietary, and thus CAS numbers and other limited information may not be available for release.

In no event shall TI's liability arising out of such information exceed the total purchase price of the TI part(s) at issue in this document sold by TI to Customer on an annual basis.

TAPE AND REEL INFORMATION

QUADRANT ASSIGNMENTS FOR PIN 1 ORIENTATION IN TAPE

*All dimensions are nominal

Device	Package Type	Package Drawing	Pins	SPQ	Reel Diameter (mm)	Reel Width W1 (mm)	A0 (mm)	B0 (mm)	K0 (mm)	P1 (mm)	W (mm)	Pin1 Quadrant
TUSB1210BRHBRQ1	VQFN	RHB	32	3000	330.0	12.4	5.3	5.3	1.1	8.0	12.0	Q2
TUSB1210BRHBTQ1	VQFN	RHB	32	250	180.0	12.4	5.3	5.3	1.1	8.0	12.0	Q2

TAPE AND REEL BOX DIMENSIONS

*All dimensions are nominal

Device	Package Type	Package Drawing	Pins	SPQ	Length (mm)	Width (mm)	Height (mm)
TUSB1210BRHBRQ1	VQFN	RHB	32	3000	367.0	367.0	35.0
TUSB1210BRHBTQ1	VQFN	RHB	32	250	210.0	185.0	35.0

GENERIC PACKAGE VIEW

RHB 32

VQFN - 1 mm max height

5 x 5, 0.5 mm pitch

PLASTIC QUAD FLATPACK - NO LEAD

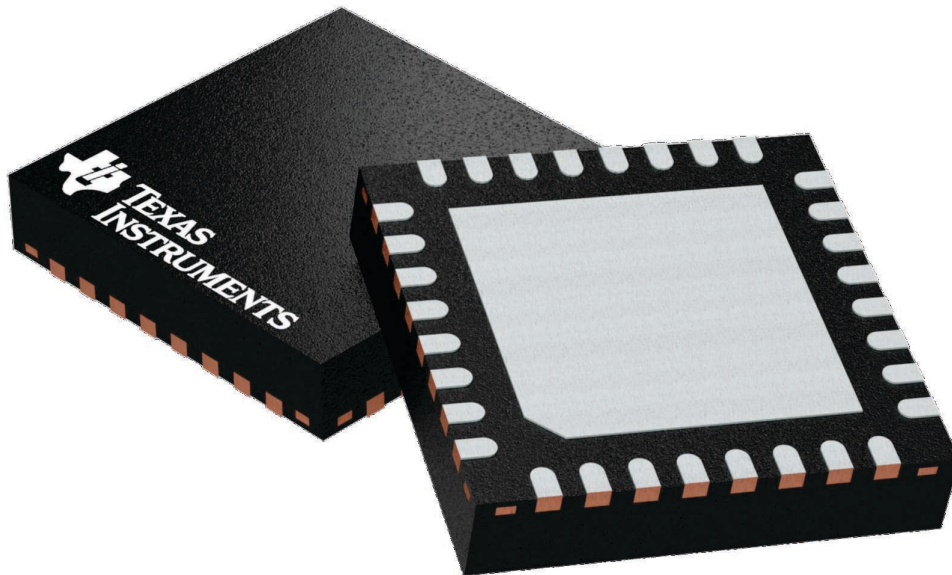

Images above are just a representation of the package family, actual package may vary.
Refer to the product data sheet for package details.

4224745/A

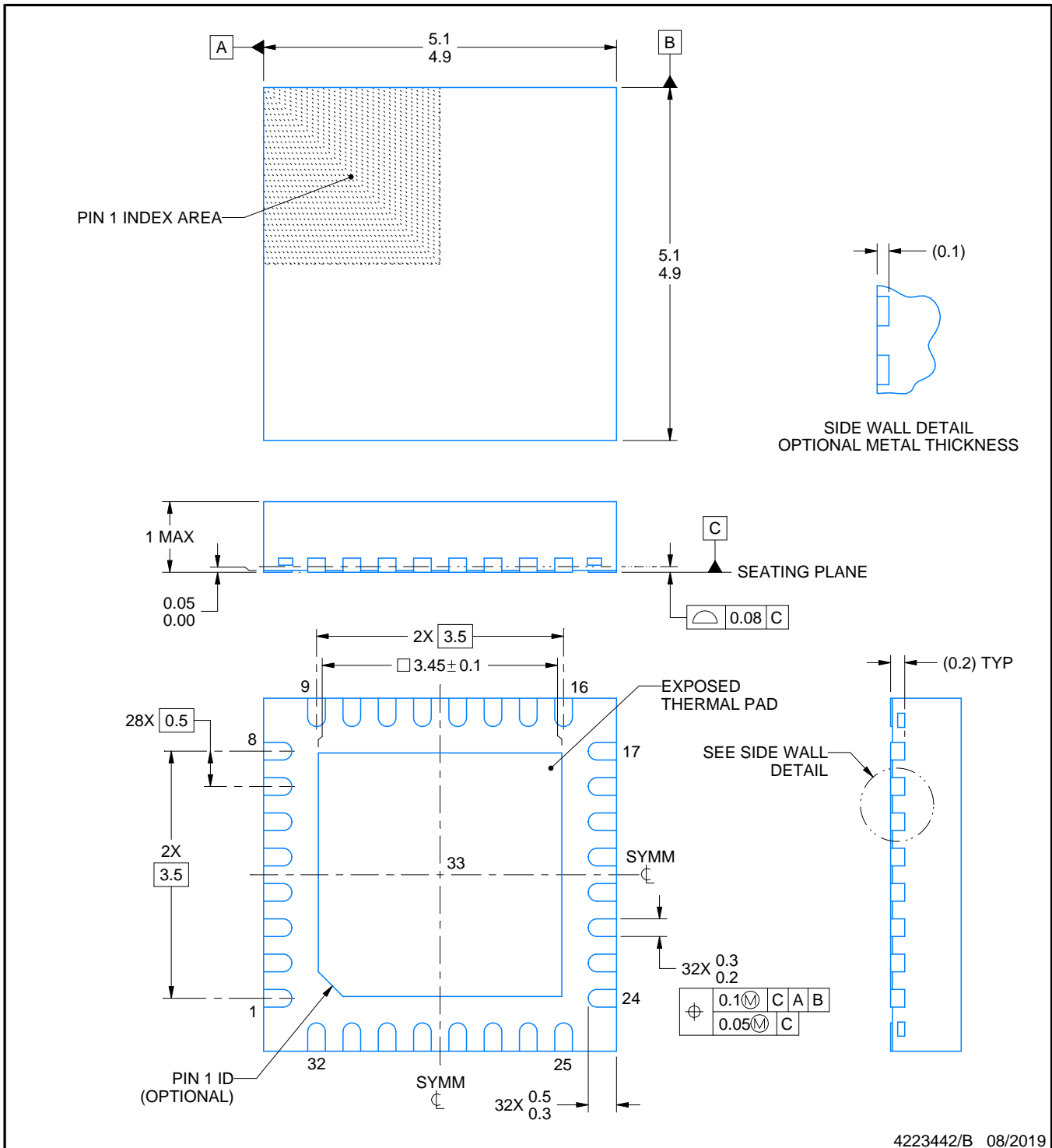
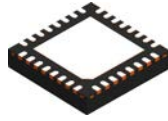

4223442/B 08/2019

NOTES:

1. All linear dimensions are in millimeters. Any dimensions in parenthesis are for reference only. Dimensioning and tolerancing per ASME Y14.5M.
2. This drawing is subject to change without notice.
3. The package thermal pad must be soldered to the printed circuit board for thermal and mechanical performance.

EXAMPLE STENCIL DESIGN

RHB0032E

VQFN - 1 mm max height

PLASTIC QUAD FLATPACK - NO LEAD

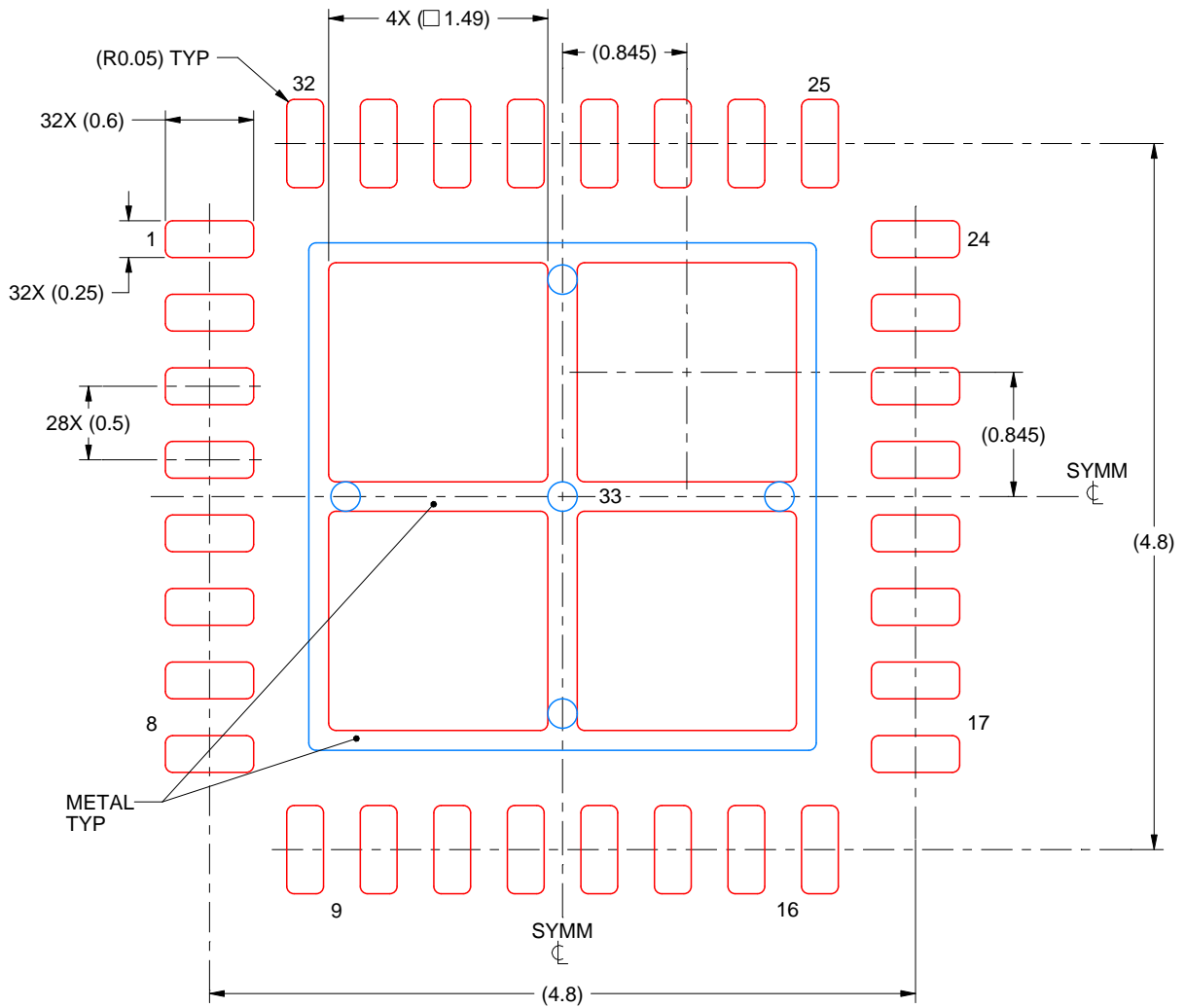

SOLDER PASTE EXAMPLE
 BASED ON 0.125 mm THICK STENCIL

EXPOSED PAD 33:
 75% PRINTED SOLDER COVERAGE BY AREA UNDER PACKAGE
 SCALE:20X

4223442/B 08/2019

NOTES: (continued)

6. Laser cutting apertures with trapezoidal walls and rounded corners may offer better paste release. IPC-7525 may have alternate design recommendations.

重要声明和免责声明

TI 均以“原样”提供技术性及其可靠性数据（包括数据表）、设计资源（包括参考设计）、应用或其他设计建议、网络工具、安全信息和其他资源，不保证其中不含任何瑕疵，且不做任何明示或暗示的担保，包括但不限于对适销性、适合某特定用途或不侵犯任何第三方知识产权的暗示担保。

所述资源可供专业开发人员应用TI 产品进行设计使用。您将对以下行为独自承担全部责任：(1) 针对您的应用选择合适的TI 产品；(2) 设计、验证并测试您的应用；(3) 确保您的应用满足相应标准以及任何其他安全、安保或其他要求。所述资源如有变更，恕不另行通知。TI 对您使用所述资源的授权仅限于开发资源所涉及TI 产品的相关应用。除此之外不得复制或展示所述资源，也不提供其它TI 或任何第三方的知识产权授权许可。如因使用所述资源而产生任何索赔、赔偿、成本、损失及债务等，TI 对此概不负责，并且您须赔偿由此对TI 及其代表造成的损害。

TI 所提供产品均受TI 的销售条款 (<http://www.ti.com.cn/zh-cn/legal/termsofsale.html>) 以及ti.com.cn上或随附TI产品提供的其他可适用条款的约束。TI提供所述资源并不扩展或以其他方式更改TI 针对TI 产品所发布的可适用的担保范围或担保免责声明。

邮寄地址：上海市浦东新区世纪大道 1568 号中建大厦 32 楼，邮政编码：200122

Copyright © 2020 德州仪器半导体技术（上海）有限公司