

Lithium Ion Charge Management IC with Integrated Switching Controller

Features

- ▶ Safe charge of Li-Ion battery packs
- ▶ Pulse-width modulation control for current and voltage regulation
- ▶ Programmable high-side/low-side current-sense
- ▶ Fast charge terminated by selectable minimum current; safety backup termination at maximum time
- ▶ Pre-charge qualification detects shorted or damaged cells and conditions battery
- ▶ Charging continuously qualified by temperature and voltage limits
- ▶ Direct LED control outputs to display charge status and fault conditions

General Description

The bq2954 Li-Ion Charge-Management IC uses a flexible pulse-width modulation regulator to control voltage and current during charging. The regulator frequency is set by an external capacitor for design flexibility. The switch-mode design minimizes power dissipation.

For safety, the bq2954 inhibits fast charging until the battery voltage and temperature are within configured limits. If the battery voltage is less than the low-voltage threshold, the bq2954 provides low-current conditioning of the battery.

For charge qualification, the bq2954 uses an external thermistor to measure battery temperature. Charging begins when power is applied or the battery is inserted.

The bq2954 charges a battery in two phases. First a constant-current phase replenishes approximately 70% of battery capacity. Then a voltage-regulation phase completes the battery charge.

The bq2954 provides status indications of all charger states and faults for accurate determination of the battery and charge-system conditions.

Pin Connections

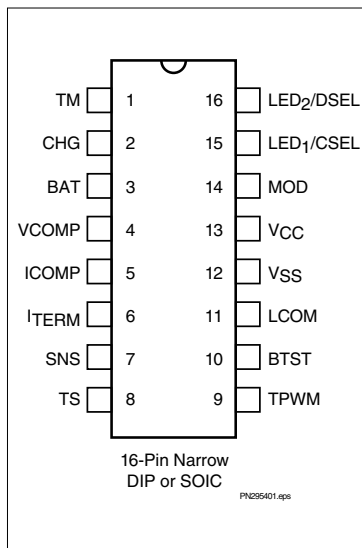

Pin Names

| | | | |
|-------|--|-----------|---|
| TM | Time-out programming input | TPWM | Regulator timebase input |
| CHG | Charge active output | BTST | Battery test output |
| BAT | Battery voltage input | LCOM | Common LED output |
| VCOMP | Voltage loop comp input | VSS | System ground |
| ICOMP | Current loop comp input | VCC | 5.0V±10% power |
| ITERM | Minimum current termination select input | MOD | Modulation control output |
| SNS | Sense resistor input | LED1/CSEL | Charge status output 1/ Charge sense select input |
| TS | Temperature sense input | LED2/DSEL | Charge status output 2/ Display select input |

bq2954

Pin Descriptions

| | | | |
|--------------|--|--|---|
| TM | Time-out programming input Sets the maximum charge time. The resistor and capacitor values are determined using Equation 5. Figure 10 shows the resistor/capacitor connection. | TPWM | Regulation timebase input Uses an external timing capacitor to ground to set the pulse-width modulation (PWM) frequency. See Equation 7. |
| CHG | Charge active output An open-drain output is driven low when the battery is removed, during a temperature pend, when a fault condition is present, or when charge is done. CHG can be used to disable a high-value load capacitor to detect quickly any battery removal. | BTST | Battery test output Driven high in the absence of a battery in order to provide a potential at the battery terminal when no battery is present. |
| BAT | Battery voltage input Sense input. This potential is generally developed using a high-impedance resistor divider network connected between the positive and the negative terminals of the battery. See Figures 6 and 7 and Equation 1. | LCOM | Common LED output Common output for LED ₁₋₂ . This output is in a high-impedance state during initialization to read programming input on DSEL and CSEL. |
| VCOMP | Voltage loop compensation input Connects to an external R-C network to stabilize the regulated voltage. | VSS | Ground |
| ICOMP | Current loop compensation input Connects to an external R-C network to stabilize the regulated current. | VCC | VCC supply 5.0V, ±10% |
| ITERM | Charge full and minimum current termination select Three-state input is used to set I _{FULL} and I _{MIN} for fast charge termination. See Table 4. | MOD | Current-switching control output Pulse-width modulated push/pull output used to control the charging current to the battery. MOD switches high to enable current flow and low to inhibit current flow. (The maximum duty cycle is 80%.) |
| SNS | Charging current sense input Battery current is sensed via the voltage developed on this pin by an external sense-resistor. | LED₁-LED₂ | Charger display status 1-2 outputs Drivers for the direct drive of the LED display. These outputs are tri-stated during initialization so that DSEL and CSEL can be read. |
| TS | Temperature sense input Used to monitor battery temperature. An external resistor-divider network sets the lower and upper temperature thresholds. (See Figures 8 and 9 and Equations 3 and 4.) | DSEL | Display select input (shared pin with LED₂) Three-level input that controls the LED ₁₋₂ charge display modes. |
| | | CSEL | Charge sense-select input (shared pin with LED₁) Input that controls whether current is sensed on low side of battery or high side of battery. A current mirror is required for high-side sense. |

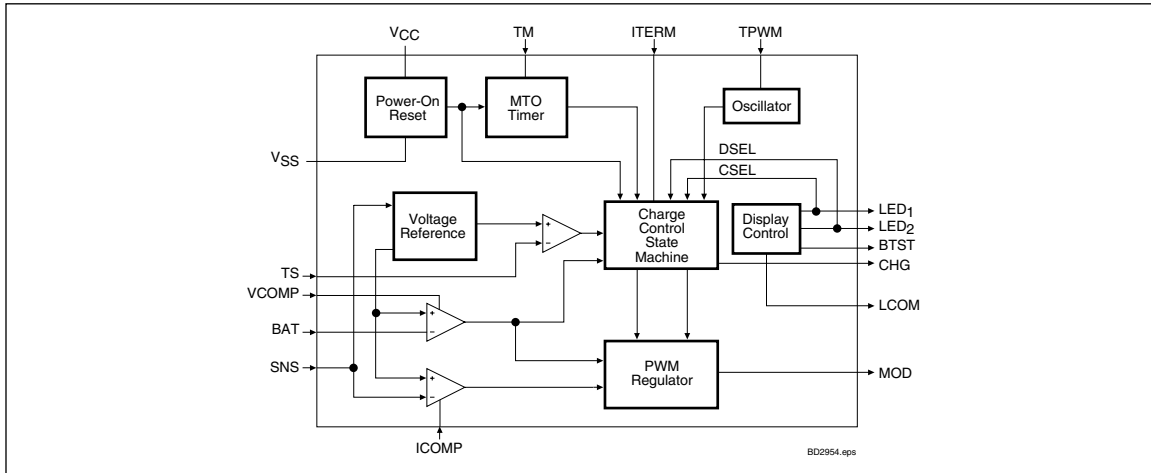

Figure 1. Functional Block Diagram

Functional Description

The bq2954 functional operation is described in terms of the following (Figure 1):

- Charge algorithm
- Charge qualification
- Charge status display
- Configuring the display and termination
- Voltage and current monitoring
- Battery insertion and removal
- Temperature monitoring
- Maximum time-out
- Charge regulation
- Recharge after fast charge

Charge Algorithm

The bq2954 uses a two-phase fast-charge algorithm. In phase 1, the bq2954 regulates constant current until the voltage on the BAT pin, V_{BAT} , rises to the internal threshold, V_{REG} . The bq2954 then transitions to phase 2 and regulates constant voltage ($V_{BAT} = V_{REG}$) until the charging current falls below the programmed I_{MIN} threshold. Fast charge then terminates, and the bq2954 enters the Charge Complete state. (See Figure 2.)

Charge Qualification

The bq2954 starts a charge cycle when power is applied while a battery is present or when a battery is inserted. Figure 2 shows the state diagram for the bq2954. The bq2954 first checks that the battery temperature is within the allowed, user-configurable range. If the temperature is out of range, the bq2954 remains in the QUALIFICATION state (S01) and waits until the battery temperature and voltage are within the allowed range.

If during any state of charge, a temperature excursion occurs HOT, the bq2954 proceeds to the DONE state (S04) and indicates this state on the LED outputs and provides no current. If this occurs, the bq2954 remains in the DONE state unless the following two conditions are met:

- Temperature falls within valid charge range
- V_{BAT} falls below the internal threshold, V_{RCHG}

If these two conditions are met, a new charge cycle begins. During any state of charge, if a temperature excursion occurs COLD, the bq2954 terminates charge and returns to the QUALIFICATION state (S01). Charge restarts if V_{BAT} and temperature are in valid range.

When the temperature and voltage are valid, the bq2954 enters the CONDITIONING state (S02) and regulates current to $I_{COND} (=I_{MAX}/10)$. After an initial holdoff period t_{HO} (which prevents the IC from reacting to transient voltage spikes that may occur when charge current is first applied), the IC begins monitoring V_{BAT} . If V_{BAT} does not rise to at least V_{MIN} before the expiration of

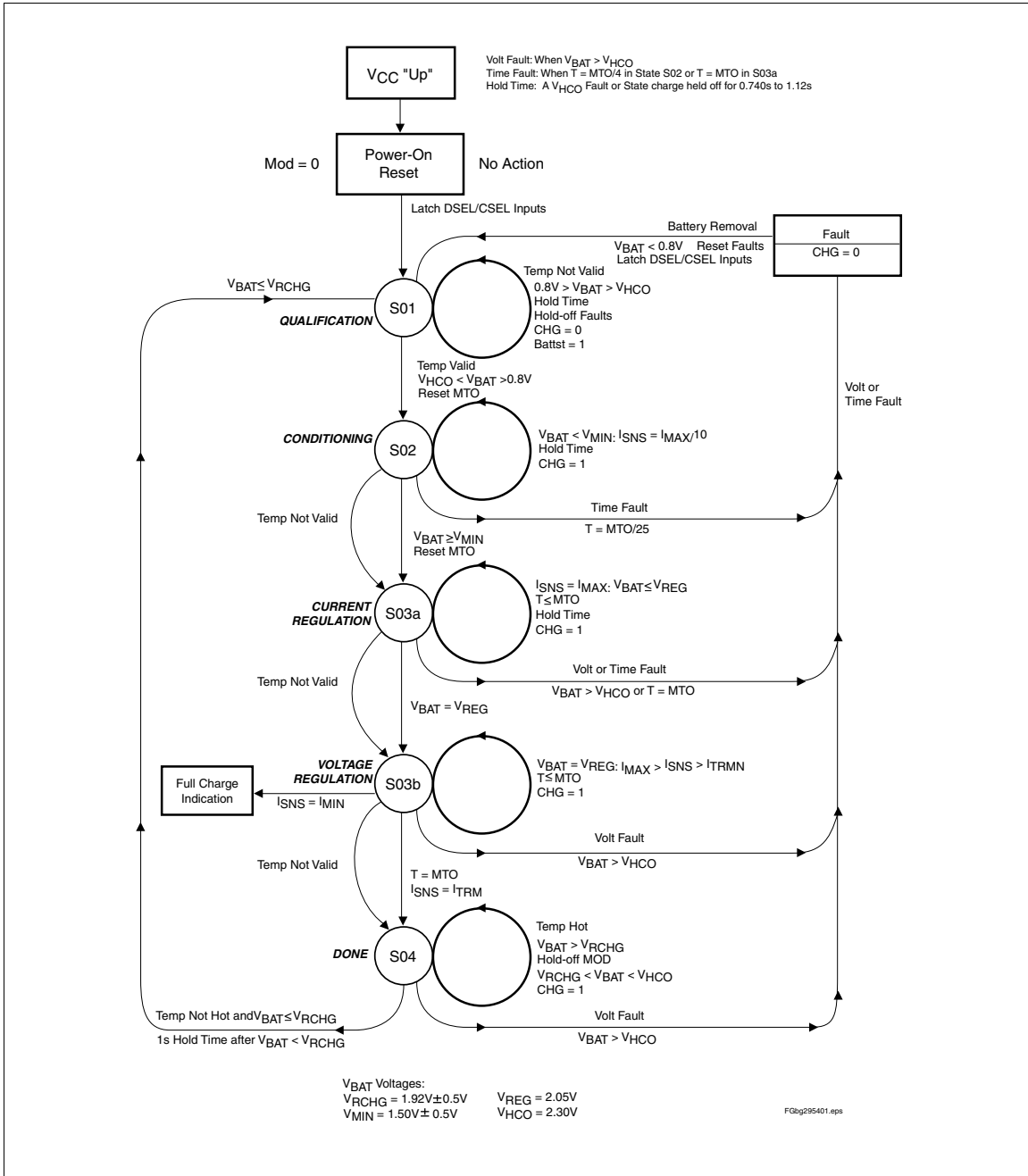

Figure 2. bq2954 Charge Algorithm

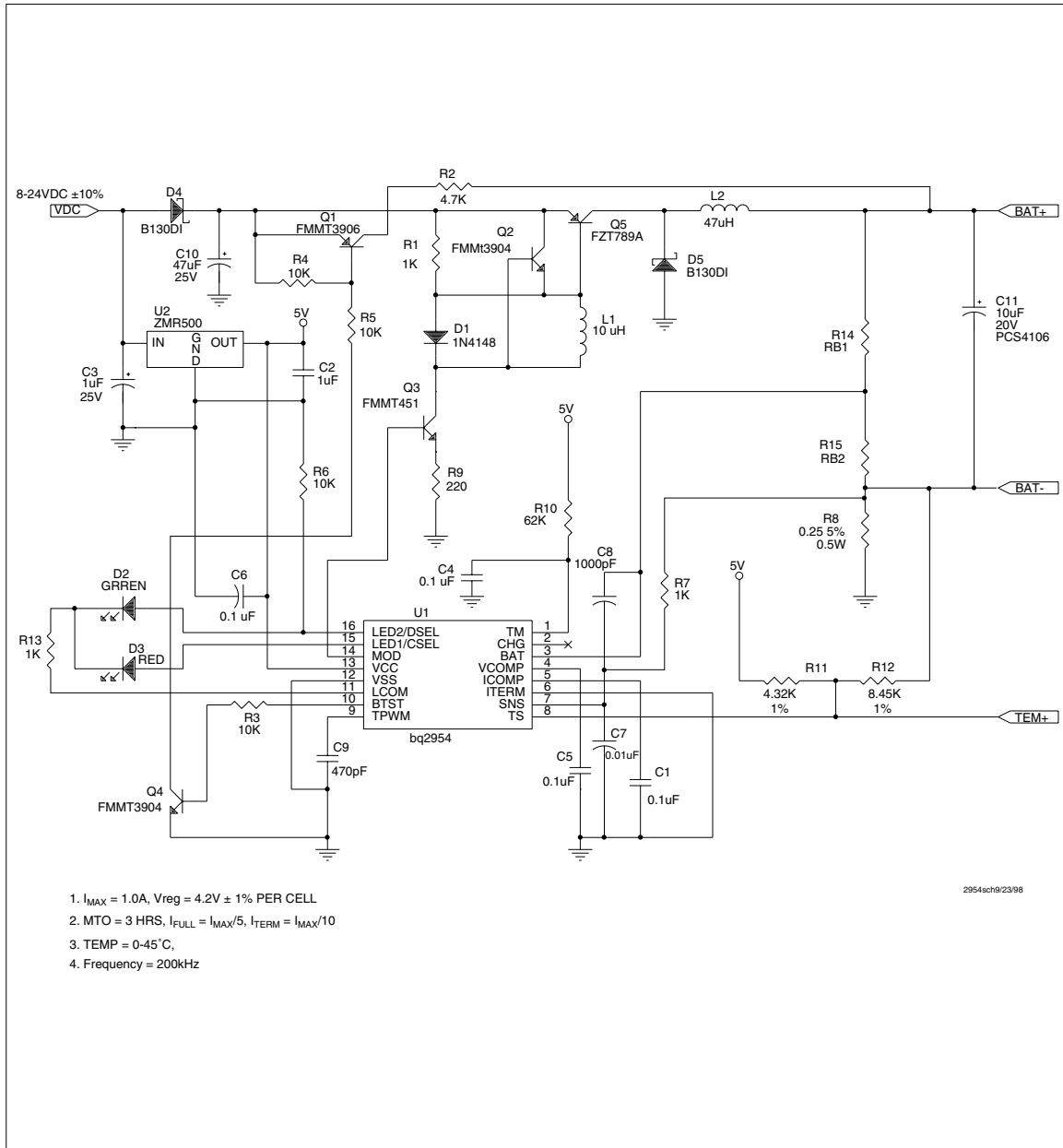
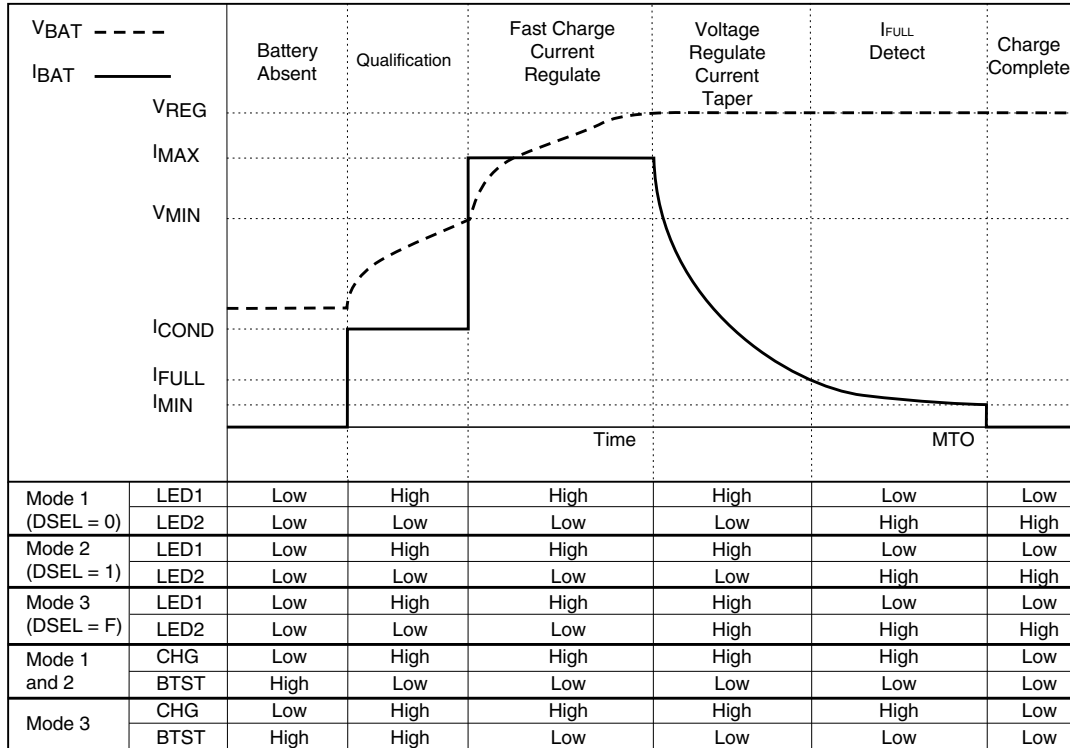

Figure 3. High-Efficiency Li-Ion Charger for 1-4 Cells

Table 1. Normal Fast Charge Cycle



GR295401.eps

time-out limit t_{QT} (i.e., the battery has failed short), the bq2954 enters the Fault state. Then t_{QT} is set to 25% of t_{MTO} . If V_{MIN} is achieved before expiration of the time limit, the bq2954 begins fast charging.

Once in the Fault state, the bq2954 waits until V_{CC} is cycled or a new battery insertion is detected. It then starts a new charge cycle and begins the qualification process again.

Charge Status Display

Charge status is indicated by the LED driver outputs LED₁–LED₂. Three display modes (Tables 1– 3) are available in the bq2954 and are selected by configuring pin DSEL. Table 1 illustrates a normal fast charge cycle, Table 2 a recharge-after-fast-charge cycle, and Table 3 an abnormal condition.

Configuring the Display Mode, I_{FULL}/I_{MIN} , and I_{SENSE}

DSEL/LED₂ and CSEL/LED₁ are bi-directional pins with two functions: as LED driver pins (output) and as programming pins (input). The selection of pull-up, pull-down, or no-resistor programs the display mode on DSEL as shown in Tables 1 through 3. A pull-down or no-resistor programs the current-sense mode on CSEL.

The bq2954 latches the programming data sensed on the DSEL and CSEL input when V_{CC} rises to a valid level. The LEDs go blank for approximately 400ms (typical) while new programming data are latched.

When fast charge reaches a condition where the charging current drops below I_{FULL} , the LED₁ and LED₂ outputs indicate a full-battery condition. Fast charge terminates when the charging current drops below the

Table 2. Recharge After Fast Charge Cycle

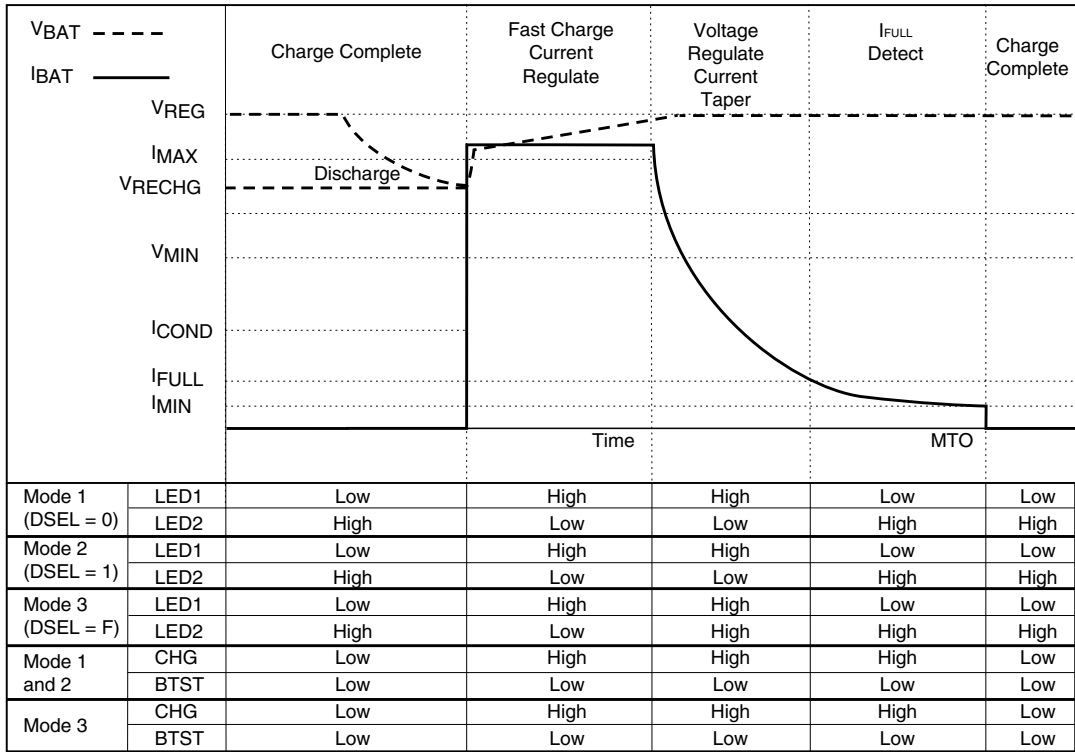

Grbq295402.eps

Table 3. Abnormal Condition

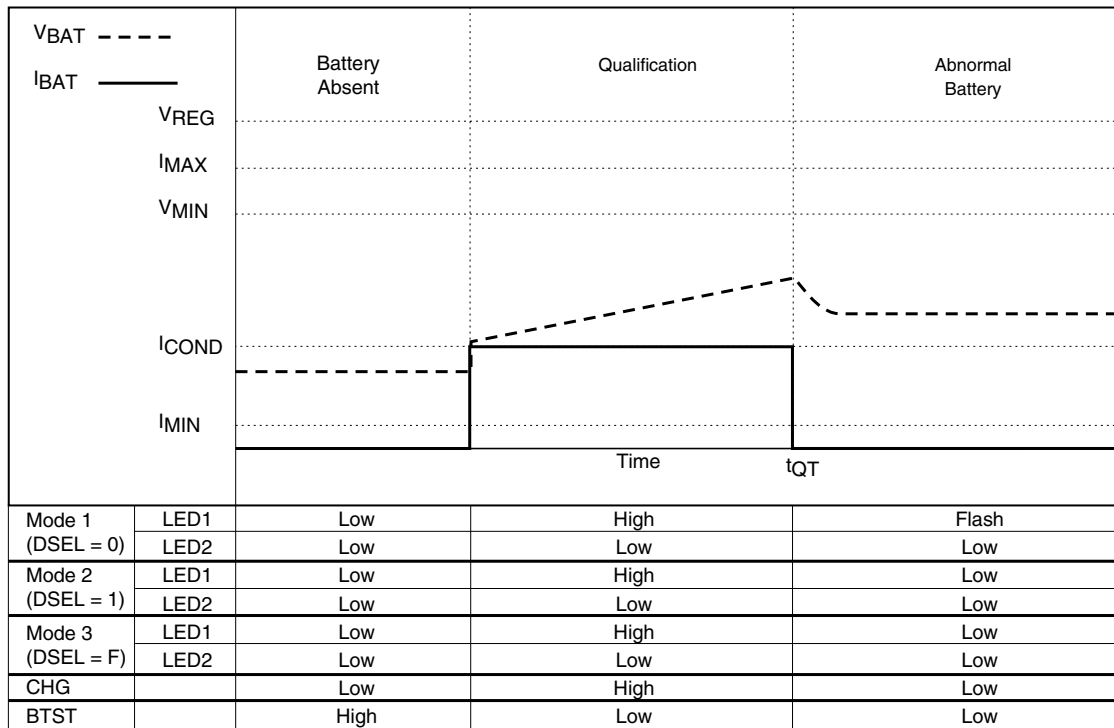

GR295403.eps

Table 4. IFULL and IMIN Thresholds

| ITERM | IFULL | IMIN |
|-------|---------|---------|
| 0 | IMAX/5 | IMAX/10 |
| 1 | IMAX/10 | IMAX/15 |
| Z | IMAX/15 | IMAX/20 |

minimum current threshold, I_{MIN} . The I_{FULL} and I_{MIN} thresholds are programmed using the I_{TERM} input pin (See Table 4.)

Figures 4 and 5 show the bq2954 configured for display mode 2 and $I_{FULL} = I_{MAX}/5$ while $I_{MIN} = I_{MAX}/10$.

Voltage and Current Monitoring

In low-side current sensing, the bq2954 monitors the battery pack voltage as a differential voltage between BAT and pins. In high-side current sensing, the bq2954 monitors the battery pack voltage as a differential voltage between BAT and VSS pins. This voltage is derived by scaling the battery voltage with a voltage divider. (See Figures 6 and 7.) The resistance of the voltage divider must be high enough to minimize battery drain but low enough to minimize noise susceptibility. $RB1 + RB2$ is typically between $150k\Omega$ and $1M\Omega$. The voltage-divider resistors are calculated from the following:

$$\frac{RB1}{RB2} = \frac{N * V_{CELL}}{V_{REG}} - 1 \quad (1)$$

where

V_{CELL} = Manufacturer-specified charging cell voltage
 N = Number of cells in series
 $V_{REG} = 2.05V$

The current sense resistor, R_{SNS} (see Figures 6 and 7), determines the fast-charge current. The value of R_{SNS} is given by the following:

$$R_{SNS} = \frac{0.25V}{I_{MAX}} \quad (2)$$

where I_{MAX} is the current during the constant-current phase of the charge cycle. (See Table 1.)

Battery Insertion and Removal

V_{BAT} is interpreted by the bq2954 to detect the presence or absence of a battery. The bq2954 determines that a battery is present when V_{BAT} is between the High-Voltage Cutoff ($V_{HCO} = V_{REG} + 0.25V$) and the Low-Voltage Cutoff ($V_{LCO} = 0.8V$). When V_{BAT} is outside this range, the bq2954 determines that no battery is present and transitions to the battery test state, testing for valid battery voltage. The bq2954 detects battery removal when V_{BAT} falls below V_{LCO} . The $BTST$ pin is driven high during battery test and can activate an external battery contact pull-up. This pull-up may be used to activate an over-discharged Li-Ion battery pack. The V_{HCO} limit implicitly serves as an over-voltage charge fault. The CHG output can be used to disconnect capacitors from the regulation circuitry in order to quickly detect a battery-removed condition.

Battery insertion is detected within 500ms. Transition to the fast-charge phase, however, will not occur for time t_{HO} (approximately one second), even if voltage qualification V_{MIN} is reached. This delay prevents a voltage spike at the BAT input from causing premature entry into the fast-charge phase. It also creates a delay in detection of battery removal if the battery is removed during this hold-off period.

Temperature Monitoring

Temperature is measured as a *differential* voltage between TS and BAT-. This voltage is typically generated by a NTC (negative temperature coefficient) thermistor and thermistor linearization network. The bq2954 compares this voltage to its internal threshold voltages to determine if charging is allowed. These thresholds are the following:

- High-Temperature Cutoff Voltage: $V_{TCO} = 0.4 * V_{CC}$
This voltage corresponds to the maximum temperature (TCO) at which charging is allowed.
- High-Temperature Fault Voltage: $V_{HTF} = 0.44 * V_{CC}$
This voltage corresponds to the temperature (HTF) at which charging resumes after exceeding TCO.
- Low-Temperature Fault Voltage: $V_{LTF} = 0.6 * V_{CC}$
This voltage corresponds to the minimum temperature (LTF) at which charging is allowed.

Charging is inhibited if the temperature is outside the LTF—TCO window. Once the temperature exceeds TCO, it must drop below HTF before charging resumes.

RT1 and RT2 for the thermistor linearization network are determined as follows:

$$0.6 * V_{CC} = \frac{V}{1 + \frac{RT1 * (RT2 + R_{LTF})}{(RT2 * R_{LTF})}} \quad (3)$$

$$0.44 = \frac{1}{1 + \frac{RT1 * (RT2 + R_{HTF})}{(RT2 * R_{HTF})}} \quad (4)$$

where

R_{LTF} = thermistor resistance at LTF

R_{HTF} = thermistor resistance at HTF

$V = V_{CC} - 0.250$ in low-side current sensing

$V = V_{CC}$ in high-side current sensing

TCO is determined by the values of RT1 and RT2. 1% resistors are recommended.

bq2954

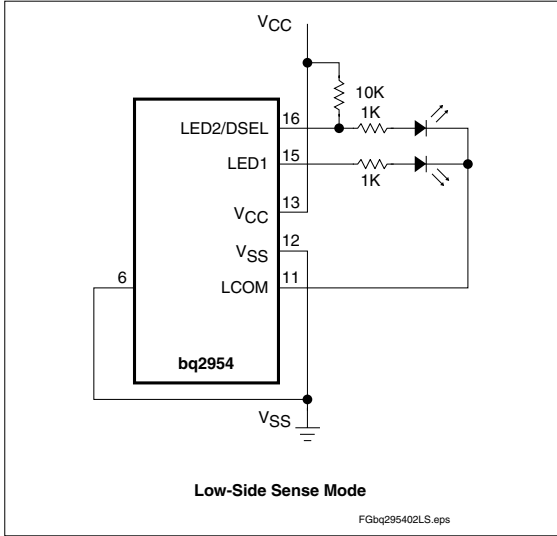

Figure 4. Configured Display Mode (Low-Side Sense)

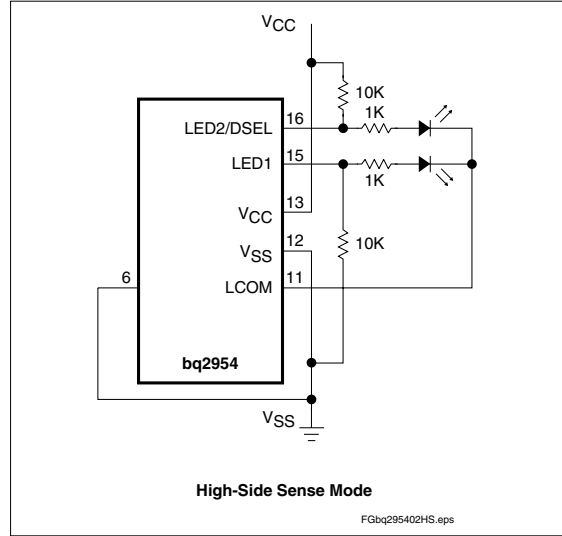

Figure 5. Configured Display Mode (High-Side Sense)

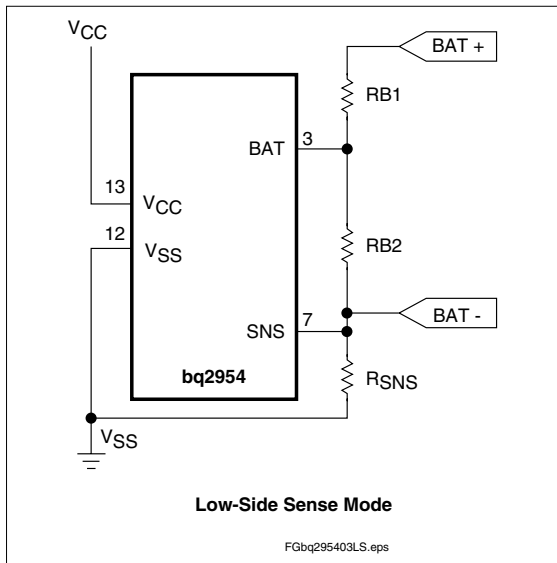

Figure 6. Configuring the Battery Divider (Low-Side Sense)

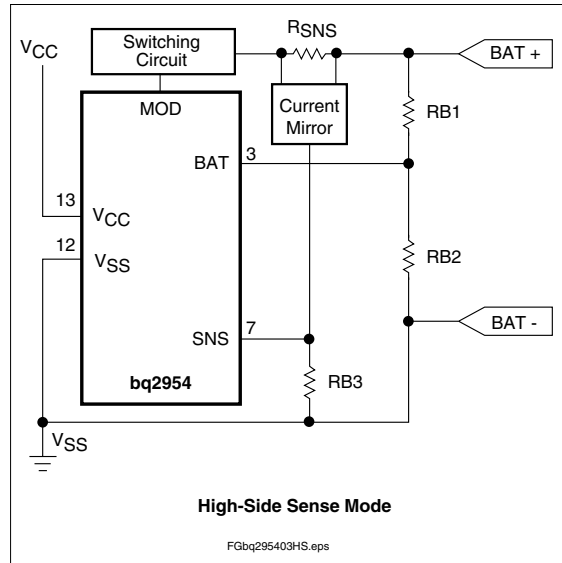

Figure 7. Configuring the Battery Divider (High-Side Sense)

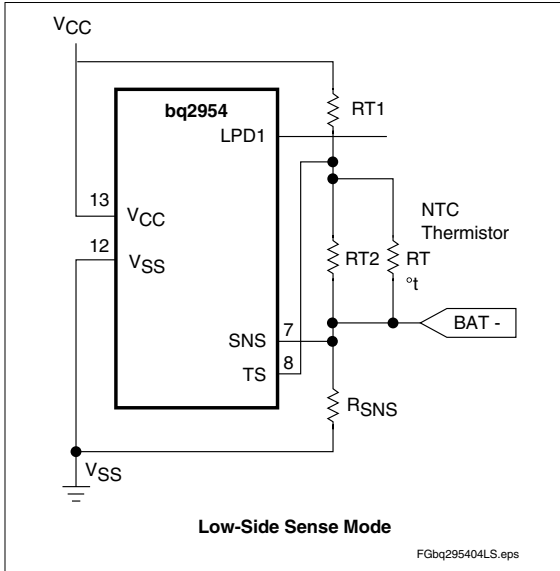

Figure 8. Low-Side Temperature Sensing

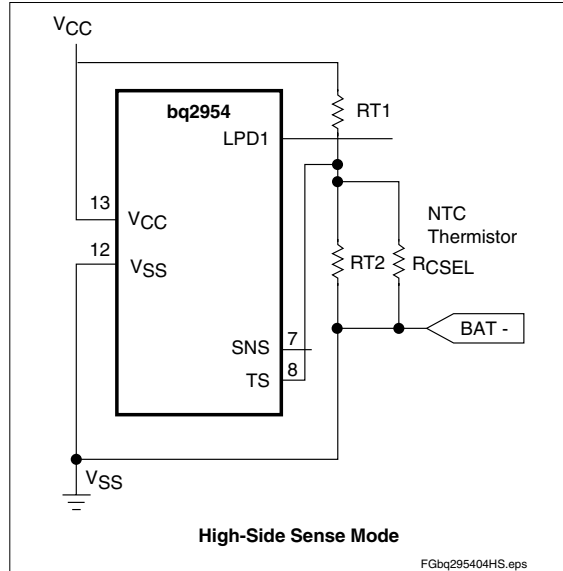

Figure 9. High-Side Temperature Sensing

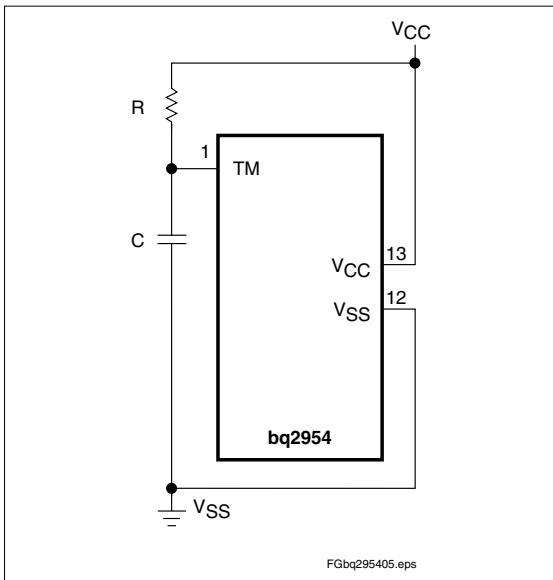

Figure 10. R-C Network/Setting MTO

Disabling Temperature Sensing

Temperature sensing can be disabled by placing a 10kΩ resistor between TS and BAT- and a 10kΩ resistor between TS and VCC. See Figures 8 and 9.

Maximum Time-Out

Maximum Time-Out period (t_{MTO}) is programmed from 1 to 24 hours by an R-C network on the TM pin (see Figure 10) per the following equation:

$$t_{MTO} = 500 * R * C \quad (5)$$

where R is in ohms, C is in Farads, and t_{MTO} is in hours. The recommended value for C is 0.1μF.

The MTO timer is reset at the beginning of fast charge. If the MTO timer expires during the voltage regulation phase, fast charging terminates and the bq2954 enters the Charge Complete state. If the conditioning phase continues for time equal to t_{QT} ($MTO/4$) and the battery potential does not reach V_{MIN} , the bq2954 enters the fault state and terminates charge. See Table 3. If the MTO timer expires during the current-regulation phase (V_{BAT} never reaches V_{REG}), fast charging is terminated, and the bq2954 enters the fault state.

bq2954

Charge Regulation

The bq2954 controls charging through pulse-width modulation of the MOD output pin, supporting both constant-current and constant-voltage regulation. Charge current is monitored at the SNS pin, and charge voltage is monitored at the BAT pin. These voltages are compared to an internal reference, and the MOD output is modulated to maintain the desired value. The maximum duty cycle is 80% .

Voltage at the SNS pin is determined by the value of resistor R_{SNS} , so nominal regulated current is set by the following equation:

$$I_{MAX} = V_{SNS} / R_{SNS} \quad (6)$$

The switching frequency of the MOD output is determined by an external capacitor (C_{PWM}) between the pin TPWM and VSS pins, per the following:

$$f_{PWM} = \frac{1 * 10^{-4}}{C_{PWM}} \quad (7)$$

Where C is in Farads and the frequency is in Hz. A typical switching rate is 100kHz, implying $C_{PWM} = 0.001\mu F$. MOD pulse width is modulated between 0 and 80% of the switching period.

To prevent oscillation in the voltage and current control loops, frequency compensation networks (C and R-C respectively) are typically required on the VCOMP and ICOMP pins .

Recharge After Fast Charge

Once charge completion occurs, a fast charge is initiated when the battery voltage falls below VRECHG threshold. A delay of approximately one second passes before recharge begins so that adequate time is allowed to detect battery removal. (See Table 1.)

Absolute Maximum Ratings

| Symbol | Parameter | Minimum | Maximum | Unit | Notes |
|---------------------|---|---------|---------|------|----------------|
| V _{CC} | V _{CC} relative to V _{SS} | -0.3 | +7.0 | V | |
| V _T | DC voltage applied on any pin excluding V _{CC} relative to V _{SS} | -0.3 | +7.0 | V | |
| T _{OPR} | Operating ambient temperature | -20 | +70 | °C | Commercial |
| | | -40 | +85 | °C | Industrial "N" |
| T _{STG} | Storage temperature | -55 | +125 | °C | |
| T _{SOLDER} | Soldering temperature | - | +260 | °C | 10s max. |

Note: Permanent device damage may occur if **Absolute Maximum Ratings** are exceeded. Functional operation should be limited to the Recommended DC Operating Conditions detailed in this data sheet. Exposure to conditions beyond the operational limits for extended periods of time may affect device reliability.

DC Thresholds (T_A = T_{OPR}; V_{CC} = 5V ± 10%)

| Symbol | Parameter | Rating | Unit | Tolerance | Notes |
|--------------------|-----------------------------------|--------------------------|-------|-----------|------------------------|
| V _{REG} | Internal reference voltage | 2.05 | V | 1% | TA = 25°C |
| | Temperature coefficient | -0.5 | mV/°C | 10% | |
| V _{LTF} | TS maximum threshold | 0.6 * V _{CC} | V | ±0.03V | Low-temperature fault |
| V _{HTF} | TS hysteresis threshold | 0.44 * V _{CC} | V | ±0.03V | High-temperature fault |
| V _{TCO} | TS minimum threshold | 0.4 * V _{CC} | V | ±0.03V | Temperature cutoff |
| V _{HCO} | High cutoff voltage | V _{REG} + 0.25V | V | ±0.03V | |
| V _{MIN} | Under-voltage threshold at BAT | 1.5 | V | ±0.05V | |
| V _{RECHG} | Recharge voltage threshold at BAT | 1.92 | V | ±0.05V | |
| V _{LCO} | Low cutoff voltage | 0.8 | V | ±0.03V | |
| V _{SNS} | Current sense at SNS | 0.250 | V | 10% | I _{MAX} |
| | | 0.025 | V | 10% | I _{COND} |

bq2954

Recommended DC Operating Conditions ($T_A = T_{OPR}$)

| Symbol | Parameter | Minimum | Typical | Maximum | Unit | Notes |
|-------------------|---|-----------------------|---------|-----------------------|------|---|
| V _{CC} | Supply voltage | 4.5 | 5.0 | 5.5 | V | |
| V _{TEMP} | TS voltage potential | 0 | - | V _{CC} | V | V _{TS} - V _{SNS} |
| V _{BAT} | BAT voltage potential | 0 | - | V _{CC} | V | |
| I _{CC} | Supply current | - | 2 | 4 | mA | Outputs unloaded |
| I _{IZ} | DSEL tri-state open detection | -2 | - | 2 | μA | Note |
| | ITERM tri-state open detection | -2 | - | 2 | μA | |
| V _{IH} | Logic input high | V _{CC} - 0.3 | - | - | V | DSEL, ITERM |
| V _{IL} | Logic input low | - | - | V _{SS} + 0.3 | V | DSEL, CSEL, ITERM |
| V _{OH} | LED ₁ , LED ₂ , BTST, output high | V _{CC} - 0.8 | - | - | V | I _{OH} ≤ 10mA |
| | MOD output high | V _{CC} - 0.8 | - | - | V | I _{OH} ≤ 10mA |
| V _{OL} | LED ₁ , LED ₂ , BTST, output low | - | - | V _{SS} + 0.8 | V | I _{OL} ≤ 10mA |
| | MOD output low | - | - | V _{SS} + 0.8 | V | I _{OL} ≤ 10mA |
| | CHG output low | - | - | V _{SS} + 0.8 | V | I _{OL} ≤ 5mA, Note 3 |
| | LCOM output low | - | - | V _{SS} + 0.5 | V | I _{OL} ≤ 30mA |
| I _{OH} | LED ₁ , LED ₂ , BTST, source | -10 | - | - | mA | V _{OH} = V _{CC} - 0.5V |
| | MOD source | -5.0 | - | - | mA | V _{OH} = V _{CC} - 0.5V |
| I _{OL} | LED ₁ , LED ₂ , BTST, sink | 10 | - | - | mA | V _{OL} = V _{SS} + 0.5V |
| | MOD sink | 5 | - | - | mA | V _{OL} = V _{SS} + 0.8V |
| | CHG sink | 5 | - | - | mA | V _{OL} = V _{SS} + 0.8V, Note 3 |
| | LCOM sink | 30 | - | - | mA | V _{OL} = V _{SS} + 0.5V |
| I _{IL} | DSEL logic input low source | - | - | +30 | μA | V = V _{SS} to V _{SS} + 0.3V, Note 2 |
| | ITERM logic input low source | - | - | +70 | μA | V = V _{SS} to V _{SS} + 0.3V |
| I _{IH} | DSEL logic input high source | -30 | - | - | μA | V = V _{CC} - 0.3V to V _{CC} |
| | ITERM logic input high source | -70 | - | - | μA | V = V _{CC} - 0.3V to V _{CC} |

- Notes:**
1. All voltages relative to V_{SS}.
 2. Conditions during initialization after V_{CC} applied.
 3. SNS = 0V.

Impedance ($T_A = T_{OPR}$; $V_{CC} = 5V \pm 10\%$)

| Symbol | Parameter | Minimum | Typical | Maximum | Unit | Notes |
|--------------------|---|---------|---------|---------|------|------------|
| R _{BATZ} | BAT pin input impedance | 50 | - | - | MΩ | |
| R _{SNSZ} | SNS pin input impedance | 50 | - | - | MΩ | |
| R _{TSZ} | TS pin input impedance | 50 | - | - | MΩ | |
| R _{PROG1} | Soft-programmed pull-up or pull-down resistor value (for programming) | - | - | 10 | kΩ | DSEL, CSEL |
| R _{PROG2} | Pull-up or pull-down resistor value | - | - | 3 | kΩ | ITERM |
| R _{MTO} | Charge timer resistor | 20 | - | 480 | kΩ | |

Timing ($T_A = T_{OPR}$; $V_{CC} = 5V \pm 10\%$)

| Symbol | Parameter | Minimum | Typical | Maximum | Unit | Notes |
|------------------|--------------------------------------|---------|-------------------------|---------|-------|----------------|
| t _{MTO} | Charge time-out range | 1 | - | 24 | hours | See Figure 10 |
| t _{QT} | Pre-charge qual test time-out period | - | 0.25 * t _{MTO} | - | - | |
| t _{HO} | Pre-charge qual test hold-off period | 300 | 600 | 900 | ms | |
| f _{PWM} | PWM regulator frequency range | - | 100 | 200 | kHz | See Equation 7 |
| d _{PWM} | Duty cycle | 0 | - | 80 | % | |

Capacitance

| Symbol | Parameter | Minimum | Typical | Maximum | Unit |
|------------------|------------------------|---------|---------|---------|------|
| C _{MTO} | Charge timer capacitor | - | - | 0.1 | μF |
| C _{PWM} | PWM capacitor | - | 0.001 | - | μF |

bq2954

16-Pin DIP Narrow (PN)

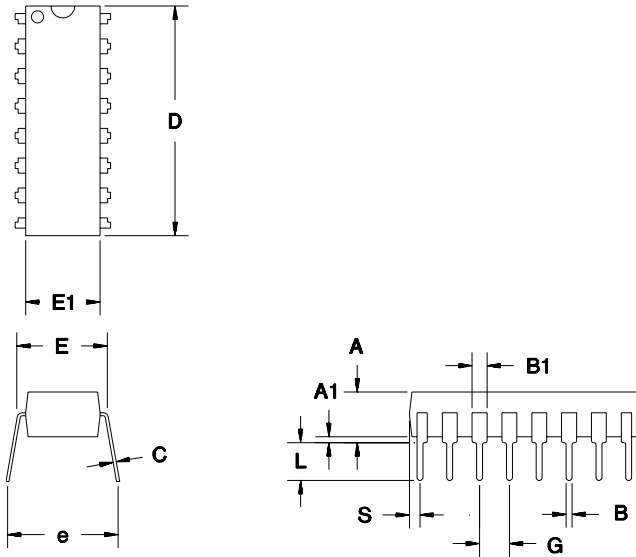

16-Pin PN (0.300" DIP)

| Dimension | Inches | | Millimeters | |
|-----------|--------|-------|-------------|-------|
| | Min. | Max. | Min. | Max. |
| A | 0.160 | 0.180 | 4.06 | 4.57 |
| A1 | 0.015 | 0.040 | 0.38 | 1.02 |
| B | 0.015 | 0.022 | 0.38 | 0.56 |
| B1 | 0.055 | 0.065 | 1.40 | 1.65 |
| C | 0.008 | 0.013 | 0.20 | 0.33 |
| D | 0.740 | 0.770 | 18.80 | 19.56 |
| E | 0.300 | 0.325 | 7.62 | 8.26 |
| E1 | 0.230 | 0.280 | 5.84 | 7.11 |
| e | 0.300 | 0.370 | 7.62 | 9.40 |
| G | 0.090 | 0.110 | 2.29 | 2.79 |
| L | 0.115 | 0.150 | 2.92 | 3.81 |
| S | 0.020 | 0.040 | 0.51 | 1.02 |

16-Pin SOIC Narrow (SN)

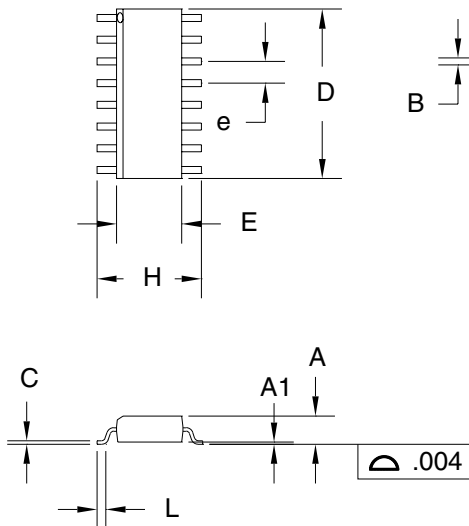

16-Pin SN (0.150" SOIC)

| Dimension | Inches | | Millimeters | |
|-----------|--------|-------|-------------|-------|
| | Min. | Max. | Min. | Max. |
| A | 0.060 | 0.070 | 1.52 | 1.78 |
| A1 | 0.004 | 0.010 | 0.10 | 0.25 |
| B | 0.013 | 0.020 | 0.33 | 0.51 |
| C | 0.007 | 0.010 | 0.18 | 0.25 |
| D | 0.385 | 0.400 | 9.78 | 10.16 |
| E | 0.150 | 0.160 | 3.81 | 4.06 |
| e | 0.045 | 0.055 | 1.14 | 1.40 |
| H | 0.225 | 0.245 | 5.72 | 6.22 |
| L | 0.015 | 0.035 | 0.38 | 0.89 |

Data Sheet Revision History

| Change No. | Page No. | Description of Change |
|------------|----------|--|
| 1 | All | “Final” changes from “Preliminary” version |

Note: Change 1 = Oct. 1998 B changes from Nov. 1997 “Preliminary.”

Ordering Information

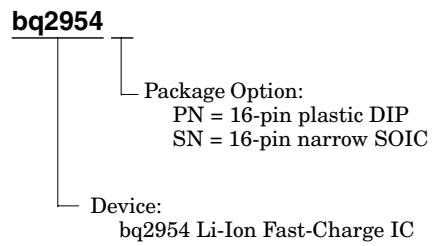

IMPORTANT NOTICE

Texas Instruments and its subsidiaries (TI) reserve the right to make changes to their products or to discontinue any product or service without notice, and advise customers to obtain the latest version of relevant information to verify, before placing orders, that information being relied on is current and complete. All products are sold subject to the terms and conditions of sale supplied at the time of order acknowledgement, including those pertaining to warranty, patent infringement, and limitation of liability.

TI warrants performance of its semiconductor products to the specifications applicable at the time of sale in accordance with TI's standard warranty. Testing and other quality control techniques are utilized to the extent TI deems necessary to support this warranty. Specific testing of all parameters of each device is not necessarily performed, except those mandated by government requirements.

CERTAIN APPLICATIONS USING SEMICONDUCTOR PRODUCTS MAY INVOLVE POTENTIAL RISKS OF DEATH, PERSONAL INJURY, OR SEVERE PROPERTY OR ENVIRONMENTAL DAMAGE ("CRITICAL APPLICATIONS"). TI SEMICONDUCTOR PRODUCTS ARE NOT DESIGNED, AUTHORIZED, OR WARRANTED TO BE SUITABLE FOR USE IN LIFE-SUPPORT DEVICES OR SYSTEMS OR OTHER CRITICAL APPLICATIONS. INCLUSION OF TI PRODUCTS IN SUCH APPLICATIONS IS UNDERSTOOD TO BE FULLY AT THE CUSTOMER'S RISK.

In order to minimize risks associated with the customer's applications, adequate design and operating safeguards must be provided by the customer to minimize inherent or procedural hazards.

TI assumes no liability for applications assistance or customer product design. TI does not warrant or represent that any license, either express or implied, is granted under any patent right, copyright, mask work right, or other intellectual property right of TI covering or relating to any combination, machine, or process in which such semiconductor products or services might be or are used. TI's publication of information regarding any third party's products or services does not constitute TI's approval, warranty or endorsement thereof.

PACKAGING INFORMATION

| Orderable Device | Status (1) | Package Type | Package Drawing | Pins | Package Qty | Eco Plan (2) | Lead finish/ Ball material (6) | MSL Peak Temp (3) | Op Temp (°C) | Device Marking (4/5) | Samples |
|------------------|---------------|--------------|-----------------|------|-------------|-----------------|--------------------------------------|----------------------|--------------|-------------------------|-------------------------|
| BQ2954PN | ACTIVE | PDIP | N | 16 | 25 | RoHS & Green | NIPDAU | N / A for Pkg Type | 0 to 70 | 2954PN-A3 | Samples |
| BQ2954SN | ACTIVE | SOIC | D | 16 | 40 | RoHS & Green | NIPDAU | Level-1-260C-UNLIM | 0 to 70 | 2954-A3 | Samples |
| BQ2954SNTR | ACTIVE | SOIC | D | 16 | 2500 | RoHS & Green | NIPDAU | Level-1-260C-UNLIM | 0 to 70 | 2954-A3 | Samples |
| BQ2954SNTRG4 | ACTIVE | SOIC | D | 16 | 2500 | RoHS & Green | NIPDAU | Level-1-260C-UNLIM | 0 to 70 | 2954-A3 | Samples |

(1) The marketing status values are defined as follows:

ACTIVE: Product device recommended for new designs.

LIFEBUY: TI has announced that the device will be discontinued, and a lifetime-buy period is in effect.

NRND: Not recommended for new designs. Device is in production to support existing customers, but TI does not recommend using this part in a new design.

PREVIEW: Device has been announced but is not in production. Samples may or may not be available.

OBSOLETE: TI has discontinued the production of the device.

(2) **RoHS:** TI defines "RoHS" to mean semiconductor products that are compliant with the current EU RoHS requirements for all 10 RoHS substances, including the requirement that RoHS substance do not exceed 0.1% by weight in homogeneous materials. Where designed to be soldered at high temperatures, "RoHS" products are suitable for use in specified lead-free processes. TI may reference these types of products as "Pb-Free".

RoHS Exempt: TI defines "RoHS Exempt" to mean products that contain lead but are compliant with EU RoHS pursuant to a specific EU RoHS exemption.

Green: TI defines "Green" to mean the content of Chlorine (Cl) and Bromine (Br) based flame retardants meet JS709B low halogen requirements of <=1000ppm threshold. Antimony trioxide based flame retardants must also meet the <=1000ppm threshold requirement.

(3) MSL, Peak Temp. - The Moisture Sensitivity Level rating according to the JEDEC industry standard classifications, and peak solder temperature.

(4) There may be additional marking, which relates to the logo, the lot trace code information, or the environmental category on the device.

(5) Multiple Device Markings will be inside parentheses. Only one Device Marking contained in parentheses and separated by a "-" will appear on a device. If a line is indented then it is a continuation of the previous line and the two combined represent the entire Device Marking for that device.

(6) Lead finish/Ball material - Orderable Devices may have multiple material finish options. Finish options are separated by a vertical ruled line. Lead finish/Ball material values may wrap to two lines if the finish value exceeds the maximum column width.

Important Information and Disclaimer:The information provided on this page represents TI's knowledge and belief as of the date that it is provided. TI bases its knowledge and belief on information provided by third parties, and makes no representation or warranty as to the accuracy of such information. Efforts are underway to better integrate information from third parties. TI has taken and

continues to take reasonable steps to provide representative and accurate information but may not have conducted destructive testing or chemical analysis on incoming materials and chemicals. TI and TI suppliers consider certain information to be proprietary, and thus CAS numbers and other limited information may not be available for release.

In no event shall TI's liability arising out of such information exceed the total purchase price of the TI part(s) at issue in this document sold by TI to Customer on an annual basis.

TAPE AND REEL INFORMATION



QUADRANT ASSIGNMENTS FOR PIN 1 ORIENTATION IN TAPE



*All dimensions are nominal

| Device | Package Type | Package Drawing | Pins | SPQ | Reel Diameter (mm) | Reel Width W1 (mm) | A0 (mm) | B0 (mm) | K0 (mm) | P1 (mm) | W (mm) | Pin1 Quadrant |
|------------|--------------|-----------------|------|------|--------------------|--------------------|---------|---------|---------|---------|--------|---------------|
| BQ2954SNTR | SOIC | D | 16 | 2500 | 330.0 | 16.4 | 6.5 | 10.3 | 2.1 | 8.0 | 16.0 | Q1 |

TAPE AND REEL BOX DIMENSIONS

*All dimensions are nominal

| Device | Package Type | Package Drawing | Pins | SPQ | Length (mm) | Width (mm) | Height (mm) |
|------------|--------------|-----------------|------|------|-------------|------------|-------------|
| BQ2954SNTR | SOIC | D | 16 | 2500 | 853.0 | 449.0 | 35.0 |

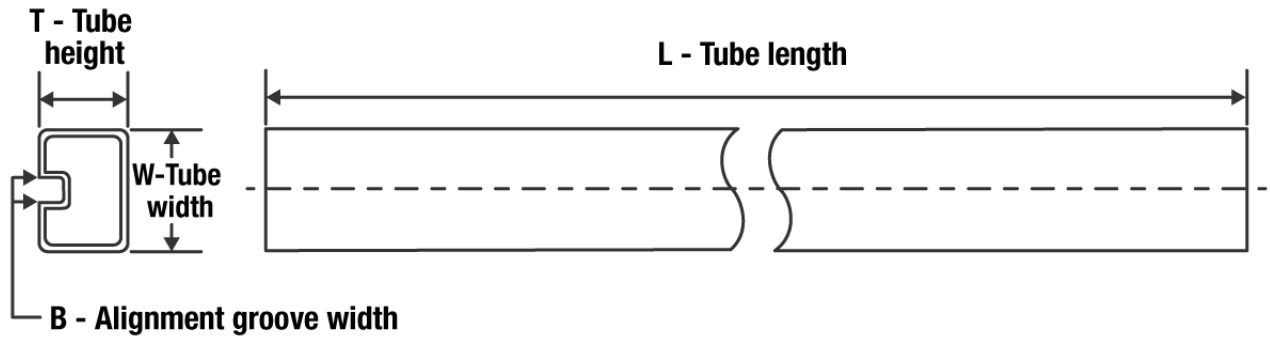
TUBE

*All dimensions are nominal

| Device | Package Name | Package Type | Pins | SPQ | L (mm) | W (mm) | T (μm) | B (mm) |
|----------|--------------|--------------|------|-----|--------|--------|--------|--------|
| BQ2954PN | N | PDIP | 16 | 25 | 506 | 13.97 | 11230 | 4.32 |
| BQ2954SN | D | SOIC | 16 | 40 | 506.6 | 8 | 3940 | 4.32 |

D (R-PDSO-G16)

PLASTIC SMALL OUTLINE



4040047-6/M 06/11

- NOTES:
- A. All linear dimensions are in inches (millimeters).
 - B. This drawing is subject to change without notice.
 -  C. Body length does not include mold flash, protrusions, or gate burrs. Mold flash, protrusions, or gate burrs shall not exceed 0.006 (0,15) each side.
 -  D. Body width does not include interlead flash. Interlead flash shall not exceed 0.017 (0,43) each side.
 - E. Reference JEDEC MS-012 variation AC.

D (R-PDSO-G16)

PLASTIC SMALL OUTLINE



- NOTES:
- All linear dimensions are in millimeters.
 - This drawing is subject to change without notice.
 - Publication IPC-7351 is recommended for alternate designs.
 - Laser cutting apertures with trapezoidal walls and also rounding corners will offer better paste release. Customers should contact their board assembly site for stencil design recommendations. Refer to IPC-7525 for other stencil recommendations.
 - Customers should contact their board fabrication site for solder mask tolerances between and around signal pads.

N (R-PDIP-T**)

PLASTIC DUAL-IN-LINE PACKAGE

16 PINS SHOWN



- NOTES:
- A. All linear dimensions are in inches (millimeters).
 - B. This drawing is subject to change without notice.
 - Falls within JEDEC MS-001, except 18 and 20 pin minimum body length (Dim A).
 - The 20 pin end lead shoulder width is a vendor option, either half or full width.

IMPORTANT NOTICE AND DISCLAIMER

TI PROVIDES TECHNICAL AND RELIABILITY DATA (INCLUDING DATA SHEETS), DESIGN RESOURCES (INCLUDING REFERENCE DESIGNS), APPLICATION OR OTHER DESIGN ADVICE, WEB TOOLS, SAFETY INFORMATION, AND OTHER RESOURCES "AS IS" AND WITH ALL FAULTS, AND DISCLAIMS ALL WARRANTIES, EXPRESS AND IMPLIED, INCLUDING WITHOUT LIMITATION ANY IMPLIED WARRANTIES OF MERCHANTABILITY, FITNESS FOR A PARTICULAR PURPOSE OR NON-INFRINGEMENT OF THIRD PARTY INTELLECTUAL PROPERTY RIGHTS.

These resources are intended for skilled developers designing with TI products. You are solely responsible for (1) selecting the appropriate TI products for your application, (2) designing, validating and testing your application, and (3) ensuring your application meets applicable standards, and any other safety, security, regulatory or other requirements.

These resources are subject to change without notice. TI grants you permission to use these resources only for development of an application that uses the TI products described in the resource. Other reproduction and display of these resources is prohibited. No license is granted to any other TI intellectual property right or to any third party intellectual property right. TI disclaims responsibility for, and you will fully indemnify TI and its representatives against, any claims, damages, costs, losses, and liabilities arising out of your use of these resources.

TI's products are provided subject to [TI's Terms of Sale](#) or other applicable terms available either on ti.com or provided in conjunction with such TI products. TI's provision of these resources does not expand or otherwise alter TI's applicable warranties or warranty disclaimers for TI products.

TI objects to and rejects any additional or different terms you may have proposed.

Mailing Address: Texas Instruments, Post Office Box 655303, Dallas, Texas 75265
Copyright © 2022, Texas Instruments Incorporated