

## ISO1050 隔离式 CAN 收发器

### 1 特性

- 满足 ISO11898-2 的要求
- 5000 V<sub>RMS</sub> 隔离 (ISO1050DW)
- 2500 V<sub>RMS</sub> 隔离
- 故障安全输出
- 低环路延迟: 150ns (典型值), 210ns (最大值)
- 50kV/ $\mu$ s 瞬态抗扰度, 典型值
- -27V 至 40V 的总线故障保护
- 驱动器 (TXD) 主导超时功能
- I/O 电压范围支持 3.3V 和 5V 微处理器
- 符合 DIN V VDE V 0884-10 (VDE V 0884-10):2006-12 和 DIN EN 61010-1 的 VDE 审批
- 已通过 UL 1577 审批
- 已通过 IEC 60950-1、IEC 61010-1、IEC 60601-1 第三版 (医疗) 和组件接受通知 5A 的 CSA 审批
- 已通过 EN/UL/CSA 60950-1 审批的 TUV 5 KV<sub>RMS</sub> 强化绝缘 (仅限 ISO1050DW)
- 符合 GB4843.1-2011 的 CQC 强化绝缘 (仅限 ISO1050DW)
- 额定工作电压下典型值为 25 年使用寿命到特性 (参见应用报告 [SLLA197](#) 和 [图 30](#))

### 2 应用

- 工业自动化、控制、传感器和驱动系统
- 楼宇和温室环境控制 (暖通空调 (HVAC)) 控制自动化
- 安防系统
- 运输
- 医疗
- 电信
- 诸如  
CANopen, DeviceNet, NMEA2000, ARNIC825, ISO11783, CAN Kingdom, CANaerospace 的 CAN 总线标准

### 3 说明

ISO1050 是一款电镀隔离的 CAN 转发器, 此转发器符合或者优于 ISO11898-2 标准的技术规范。此器件有几个由二氧化硅 (SiO<sub>2</sub>) 绝缘隔栅分开的逻辑输入和输出缓冲器, 此绝缘隔栅为说明第一段中的 ISO1050DW 和针对 ISO1050DUB 的 2500 V<sub>RMS</sub>。与隔离式电源一起使用, 此器件可防止数据总线或者其它电路上的噪音电流进入本地接地并干扰和损坏敏感电路。

作为 CAN 收发器, 该器件可为总线和 CAN 控制器分别提供差分发射能力和差分接收能力, 信号传输速率高达 1 兆位每秒 (Mbps)。该器件尤其适合工作在恶劣环境下, 其具有串线、过压和接地损耗保护 (-27V 至 40V) 以及过热关断功能, 共模电压范围为 -12V 至 12V。

ISO1050 的额定工作环境温度范围为 -55°C 至 105°C。

器件信息<sup>(1)</sup>

| 器件型号    | 封装        | 封装尺寸 (标称值)       |
|---------|-----------|------------------|
| ISO1050 | SOP (8)   | 9.50mm x 6.57mm  |
|         | SOIC (16) | 10.30mm x 7.50mm |

(1) 要了解所有可用封装, 请见数据表末尾的可订购产品附录。

简化电路原理图

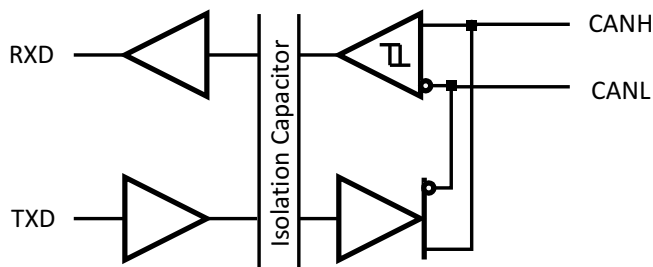

## 目录

|          |  |           |           |   |           |
|----------|--|-----------|-----------|---|-----------|
| <b>1</b> | <b>特性</b> .....                                  | <b>1</b>  | <b>8</b>  | <b>Detailed Description</b> .....           | <b>15</b> |
| <b>2</b> | <b>应用</b> .....                                  | <b>1</b>  | 8.1       | Overview .....                              | 15        |
| <b>3</b> | <b>说明</b> .....                                  | <b>1</b>  | 8.2       | Functional Block Diagram .....              | 15        |
| <b>4</b> | <b>修订历史记录</b> .....                              | <b>2</b>  | 8.3       | Feature Description .....                   | 15        |
| <b>5</b> | <b>Pin Configuration and Functions</b> .....     | <b>5</b>  | 8.4       | Device Functional Modes .....               | 20        |
| <b>6</b> | <b>Specifications</b> .....                      | <b>6</b>  | <b>9</b>  | <b>Application and Implementation</b> ..... | <b>22</b> |
| 6.1      | Absolute Maximum Ratings .....                   | 6         | 9.1       | Application Information .....               | 22        |
| 6.2      | ESD Ratings .....                                | 6         | 9.2       | Typical Application .....                   | 22        |
| 6.3      | Recommended Operating Conditions .....           | 6         | <b>10</b> | <b>Power Supply Recommendations</b> .....   | <b>25</b> |
| 6.4      | Thermal Information .....                        | 7         | <b>11</b> | <b>Layout</b> .....                         | <b>25</b> |
| 6.5      | Electrical Characteristics: Supply Current ..... | 7         | 11.1      | Layout Guidelines .....                     | 25        |
| 6.6      | Electrical Characteristics: Driver .....         | 7         | 11.2      | Layout Example .....                        | 25        |
| 6.7      | Electrical Characteristics: Receiver .....       | 8         | <b>12</b> | <b>器件和文档支持</b> .....                        | <b>26</b> |
| 6.8      | Switching Characteristics: Device .....          | 8         | 12.1      | 文档支持 .....                                  | 26        |
| 6.9      | Switching Characteristics: Driver .....          | 8         | 12.2      | 商标 .....                                    | 26        |
| 6.10     | Switching Characteristics: Receiver .....        | 9         | 12.3      | 静电放电警告 .....                                | 26        |
| 6.11     | Typical Characteristics .....                    | 9         | 12.4      | 术语表 .....                                   | 26        |
| <b>7</b> | <b>Parameter Measurement Information</b> .....   | <b>10</b> | <b>13</b> | <b>机械封装和可订购信息</b> .....                     | <b>26</b> |

## 4 修订历史记录

NOTE: Page numbers for previous revisions may differ from page numbers in the current version.

| <b>Changes from Revision H (June 2013) to Revision I</b>   | <b>Page</b> |
|--|-------------|
| • 已添加 引脚配置和功能部分, ESD 额定值表, 特性描述部分, 器件功能模式, 应用和实施部分, 电源相关建议部分, 布局部分, 器件和文档支持部分以及机械、封装和可订购信息部分 ..... | 1           |

| <b>Changes from Revision G (March 2013) to Revision H</b>   | <b>Page</b> |
|---|-------------|
| • Changed title From: LIFE EXPECTANCY vs WORKING VOLTAGE (ISO1050DW To: LIFE EXPECTANCY vs WORKING VOLTAGE (ISO1050DUB) ..... | 21          |

| <b>Changes from Revision F (January 2013) to Revision G</b>   | <b>Page</b> |
|---|-------------|
| • Clarified clearance and creepage measurement method in ISOLATOR CHARACTERISTICS .....   | 15          |
| • Clarified test methods for voltage ratings in INSULATION CHARACTERISTICS .....  | 16          |
| • Changed UL Single Protection Certification pending to Single Protection in REGULATORY INFORMATION SECTION (certificate available) ..... | 17          |

| <b>Changes from Revision E (December 2011) to Revision F</b>       | <b>Page</b> |
|--|-------------|
| • 已删除 ISO1050L 器件 .....  | 1           |
| • 已删除 (ISO1050DUB 和ISO1050LDW) .....                               | 1           |
| • 已删除 说明第一段中的 ISO1050LDW .....                                     | 1           |
| • Added the PIN FUNCTIONS section .....                            | 5           |
| • Added Note 1 to the DRIVER SWITCHING CHARACTERISTICS table ..... | 8           |
| • 已删除 ISO1050LDW from INSULATION CHARACTERISTICS .....             | 16          |
| • 已删除 ISO1050LDW from REGULATORY INFORMATION .....                 | 17          |
| • 已添加 the FUNCTIONAL DESCRIPTION section .....                     | 17          |
| • 已删除 ISO1050LDW from LIFE EXPECTANCY vs WORKING VOLTAGE .....     | 21          |

|  |    |
|--|----|
| • Deleted 40V from the CANH and CANL input diagrams and output diagrams in the EQUIVALENT I/O SCHEMATICS ..... | 21 |
| • Changed the APPLICATION INFORMATION section.....   | 22 |
| • 已更改 the BUS LOADING, LENGHT AND NUMBER OF NODES section.....   | 22 |
| • 已添加 the CAN TERMINATION section.....   | 23 |

**Changes from Revision D (June 2011) to Revision E**
**Page**

|  |    |
|--|----|
| • 已添加 器件 ISO1050L .....  | 1  |
| • 已更改 特性列表中的 (DW 封装) .....   | 1  |
| • 已更改 特性列表中的 (DUB 封装) 在 (ISO1050DUB和ISO1050LDW) .....  | 1  |
| • 已将 IEC 60950-1 从 CSA 审批特性要点删除 .....  | 1  |
| • 从: IEC 60601-1 (医疗) 和 CSA 审批正在审理中至: 已通过 IEC 60601-1 (医疗) 和 CSA 审批 .....                                | 1  |
| • 添加了特性 - 5 KVRMS 增强.. .....   | 1  |
| • Added Note 1 to the INSULATION CHARACTERISTICS table.....  | 16 |
| • 已更改 $V_{IORM}$ From: 8-DUB Package to ISO1050DUB and ISO1050LDW .....                                  | 16 |
| • 已更改 $V_{IORM}$ From: 16-DW to ISO1050DW .....  | 16 |
| • 已更改 the $V_{ISO}$ Isolation voltage per UL section of the INSULATION CHARACTERISTICS table.....        | 16 |
| • Changed the IEC 60664-1 Ratings Table .....  | 16 |
| • 已更改 the REGULATORY INFORMATION table.....  | 17 |
| • 已更改 in note (1) 3000 to 2500 and 6000 to 5000 .....  | 17 |
| • Changed From: File Number: 220991 (Approval Pending) To: File Number: 220991.....                      | 17 |
| • 已更改 in LIFE EXPECTANCY vs WORKING VOLTAGE (8-DUB PACKAGE TO: LIFE.....(ISO1050DW and ISO1050LDW) ..... | 21 |

**Changes from Revision C (July 2010) to Revision D**
**Page**

|  |    |
|--|----|
| • 已更改 the SUPPLY CURRENT table for $I_{CC1}$ 1st row From: Typ = 1 To: 1.8 and MAX = 2 To: 2.8.....  | 7  |
| • 已更改 the SUPPLY CURRENT table for $I_{CC1}$ 2nd row From: Typ = 2 To: 2.8 and MAX = 3 To: 3.6 ..... | 7  |
| • 已更改 the REGULATORY INFORMATION table.....  | 17 |

**Changes from Revision B (June 2009) to Revision C**
**Page**

|   |    |
|---|----|
| • 已更改 IEC 60747-5-2 特性要点从: DW 封装审批正在审理中至: DUB 和 DW 封装已通过 VDE 审批 .....                               | 1  |
| • 已更改 the Minimum Internal Gap value from 0.008 to 0.014 in the Isolator Characteristics table..... | 15 |
| • 已更改 $V_{IORM}$ Specification From: 1300 To: 1200 per VDE certification.....                       | 16 |
| • 已更改 $V_{PR}$ Specification From 2438 To: 2250.....  | 16 |
| • 已添加 the Bus Loading paragraph to the Application Information section .....                        | 22 |

---

**Changes from Revision A (Sept 2009) to Revision B** **Page**

- 已添加 已通过 IEC 60747-5-2 和 IEC61010-1 审批的信息..... 1
  - Changed DW package from preview to production data..... 5
  - 已添加 Insulation Characteristics and IEC 60664-1 Ratings tables ..... 16
  - 已添加 IEC file number ..... 17
- 

**Changes from Original (June 2009) to Revision A** **Page**

- 已添加 额定工作电压下典型值为 25 年使用寿命到特性 ..... 1
  - 已添加 LIFE EXPECTANCY vs WORKING VOLTAGE section ..... 21
-

## 5 Pin Configuration and Functions

16-Pin  
DW Package  
Top View

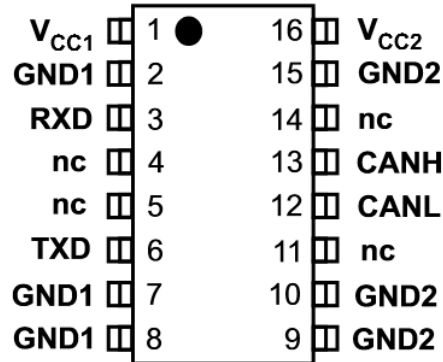

8-Pin  
DUB Package  
Top View

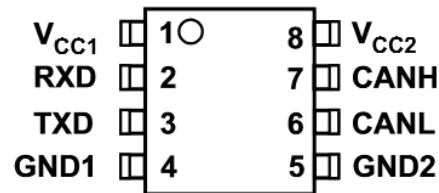

Pin Functions

| NAME             | PIN |     | TYPE   | DESCRIPTION  |
|------------------|-----|-----|--------|--|
|                  | DW  | DUB |        |  |
| V <sub>CC1</sub> | 1   | 1   | Supply | Digital-side supply voltage (3 to 5.5 V)                                     |
| GND1             | 2   | —   | Ground | Digital-side ground connection   |
| RXD              | 3   | 2   | O      | CAN receive data output (LOW for dominant and HIGH for recessive bus states) |
| NC               | 4   | —   | NC     | No connect   |
| NC               | 5   | —   | NC     | No connect   |
| TXD              | 6   | 3   | I      | CAN transmit data input (LOW for dominant and HIGH for recessive bus states) |
| GND1             | 7   | 4   | Ground | Digital-side ground connection   |
| GND1             | 8   | —   | Ground | Digital-side ground connection   |
| GND2             | 9   | 5   | Ground | Transceiver-side ground connection   |
| GND2             | 10  | —   | Ground | Transceiver-side ground connection   |
| NC               | 11  | —   | NC     | No connect   |
| CANL             | 12  | 6   | I/O    | Low-level CAN bus line   |
| CANH             | 13  | 7   | I/O    | High-level CAN bus line  |
| NC               | 14  | —   | NC     | No connect   |
| GND2             | 15  | —   | Ground | Transceiver-side ground connection   |
| V <sub>CC2</sub> | 16  | 8   | Supply | Transceiver-side supply voltage (5 V)  |

## 6 Specifications

### 6.1 Absolute Maximum Ratings<sup>(1)(2)</sup>

|                          |  | MIN  | MAX                            | UNIT |
|--------------------------|--|------|--------------------------------|------|
| $V_{CC1}, V_{CC2}$       | Supply voltage <sup>(3)</sup>            | -0.5 | 6                              | V    |
| $V_I$                    | Voltage input (TXD)                      | -0.5 | $V_{CC1} + 0.5$ <sup>(4)</sup> | V    |
| $V_{CANH}$ or $V_{CANL}$ | Voltage at any bus terminal (CANH, CANL) | -27  | 40                             | V    |
| $I_O$                    | Receiver output current                  | -15  | 15                             | mA   |
| $T_J$                    | Junction temperature                     | -55  | 150                            | °C   |
| $T_{stg}$                | Storage temperature                      | -65  | 150                            | °C   |

- (1) Stresses beyond those listed under *Absolute Maximum Ratings* may cause permanent damage to the device. These are stress ratings only and functional operation of the device at these or any other conditions beyond those indicated under *Recommended Operating Conditions* is not implied. Exposure to absolute-maximum-rated conditions for extended periods may affect device reliability.
- (2) This isolator is suitable for isolation within the safety limiting data. Maintenance of the safety data must be ensured by means of protective circuitry.
- (3) All input and output logic voltage values are measured with respect to the GND1 logic side ground. Differential bus-side voltages are measured to the respective bus-side GND2 ground terminal.
- (4) Maximum voltage must not exceed 6 V.

### 6.2 ESD Ratings

|  |  | VALUE | UNIT |
|--|--|-------|------|
| $V_{(ESD)}$                                | Electrostatic discharge  |       |      |
|  | Human body model (HBM), per ANSI/ESDA/JEDEC JS-001, all pins <sup>(1)</sup>              | ±4000 | V    |
|  | Charged device model (CDM), per JEDEC specification JESD22-C101, all pins <sup>(2)</sup> | ±1500 |      |
| Machine model, ANSI/ESDS5.2-1996, all pins | ±200   |       |      |

- (1) JEDEC document JEP155 states that 500-V HBM allows safe manufacturing with a standard ESD control process.
- (2) JEDEC document JEP157 states that 250-V CDM allows safe manufacturing with a standard ESD control process.

### 6.3 Recommended Operating Conditions

|                   |   |   | MIN                | NOM | MAX  | UNIT |
|-------------------|---|---|--------------------|-----|------|------|
| $V_{CC1}$         | Supply voltage, controller side                                 |   | 3                  |     | 5.5  | V    |
| $V_{CC2}$         | Supply voltage, bus side  |   | 4.75               | 5   | 5.25 | V    |
| $V_I$ or $V_{IC}$ | Voltage at bus pins (separately or common mode)                 |   | -12 <sup>(1)</sup> |     | 12   | V    |
| $V_{IH}$          | High-level input voltage  | TXD   | 2                  |     | 5.25 | V    |
| $V_{IL}$          | Low-level input voltage   | TXD   | 0                  |     | 0.8  | V    |
| $V_{ID}$          | Differential input voltage                                      |   | -7                 |     | 7    | V    |
| $I_{OH}$          | High-level output current                                       | Driver  | -70                |     |      | mA   |
|                   |   | Receiver  | -4                 |     |      |      |
| $I_{OL}$          | Low-level output current  | Driver  |                    |     | 70   | mA   |
|                   |   | Receiver  |                    |     | 4    |      |
| $T_A$             | Ambient Temperature   |   | -55                |     | 105  | °C   |
| $T_J$             | Junction temperature (see <a href="#">Thermal Information</a> ) |   | -55                |     | 125  | °C   |
| $P_D$             | Total power dissipation   | $V_{CC1} = 5.5V, V_{CC2} = 5.25V, T_A = 105°C, R_L = 60\Omega,$<br>TXD input is a 500kHz 50% duty-cycle square wave |                    |     | 200  | mW   |
| $P_{D1}$          | Power dissipation by Side-1                                     |   |                    |     | 25   |      |
| $P_{D2}$          | Power dissipation by Side-2                                     |   |                    |     | 175  |      |
| $T_{j\ shutdown}$ | Thermal shutdown temperature <sup>(2)</sup>                     |   |                    | 190 |      | °C   |

- (1) The algebraic convention, in which the least positive (most negative) limit is designated as minimum is used in this data sheet.
- (2) Extended operation in thermal shutdown may affect device reliability.

## 6.4 Thermal Information

| THERMAL METRIC <sup>(1)</sup> |  | ISO1050 |        | UNIT |
|-------------------------------|--|---------|--------|------|
|                               |  | DW      | DUB    |      |
|                               |  | 16 PINS | 8 PINS |      |
| R <sub>θJA</sub>              | Junction-to-ambient thermal resistance       | 76.0    | 73.3   | °C/W |
| R <sub>θJC(top)</sub>         | Junction-to-case (top) thermal resistance    | 41      | 63.2   |      |
| R <sub>θJB</sub>              | Junction-to-board thermal resistance         | 47.7    | 43.0   |      |
| ψ <sub>JT</sub>               | Junction-to-top characterization parameter   | 14.4    | 27.4   |      |
| ψ <sub>JB</sub>               | Junction-to-board characterization parameter | 38.2    | 42.7   |      |
| R <sub>θJC(bot)</sub>         | Junction-to-case (bottom) thermal resistance | n/a     | n/a    |      |

(1) For more information about traditional and new thermal metrics, see the *IC Package Thermal Metrics* application report, [SPRA953](#).

## 6.5 Electrical Characteristics: Supply Current

over recommended operating conditions (unless otherwise noted)

| PARAMETER        |                                 | TEST CONDITIONS  | MIN                               | TYP <sup>(1)</sup> | MAX | UNIT |
|------------------|---------------------------------|--|-----------------------------------|--------------------|-----|------|
| I <sub>CC1</sub> | V <sub>CC1</sub> Supply current | V <sub>I</sub> = 0 V or V <sub>CC1</sub> , V <sub>CC1</sub> = 3.3V |                                   | 1.8                | 2.8 | mA   |
|                  |                                 | V <sub>I</sub> = 0 V or V <sub>CC1</sub> , V <sub>CC1</sub> = 5V   |                                   | 2.3                | 3.6 |      |
| I <sub>CC2</sub> | V <sub>CC2</sub> Supply current | Dominant   |                                   | 52                 | 73  | mA   |
|                  |                                 | Recessive  | V <sub>I</sub> = V <sub>CC1</sub> | 8                  | 12  |      |

(1) All typical values are at 25°C with V<sub>CC1</sub> = V<sub>CC2</sub> = 5 V.

## 6.6 Electrical Characteristics: Driver

over recommended operating conditions (unless otherwise noted)

| PARAMETER           |   | TEST CONDITIONS   | MIN  | TYP   | MAX  | UNIT  |       |
|---------------------|---|---|------|-------|------|-------|-------|
| V <sub>O(D)</sub>   | Bus output voltage (Dominant)             | See <a href="#">图 7</a> and <a href="#">图 8</a> , V <sub>I</sub> = 0 V, R <sub>L</sub> = 60 Ω   | CANH | 2.9   | 3.5  | 4.5   | V     |
|                     |   |   | CANL | 0.8   | 1.2  | 1.5   |       |
| V <sub>O(R)</sub>   | Bus output voltage (Recessive)            | See <a href="#">图 7</a> and <a href="#">图 8</a> , V <sub>I</sub> = 2 V, R <sub>L</sub> = 60 Ω   | 2    | 2.3   | 3    | V     |       |
| V <sub>OD(D)</sub>  | Differential output voltage (Dominant)    | See <a href="#">图 7</a> , <a href="#">图 8</a> and <a href="#">图 9</a> , V <sub>I</sub> = 0 V, R <sub>L</sub> = 60 Ω                         |      | 1.5   |      | 3     | V     |
|                     |   | See <a href="#">图 7</a> , <a href="#">图 8</a> , and <a href="#">图 9</a> V <sub>I</sub> = 0 V, R <sub>L</sub> = 45Ω, V <sub>CC</sub> > 4.8 V |      | 1.4   |      | 3     |       |
| V <sub>OD(R)</sub>  | Differential output voltage (Recessive)   | See <a href="#">图 7</a> and <a href="#">图 8</a> , V <sub>I</sub> = 3 V, R <sub>L</sub> = 60 Ω   |      | -0.12 |      | 0.012 | V     |
|                     |   | V <sub>I</sub> = 3 V, No Load   |      | -0.5  |      | 0.05  |       |
| V <sub>OC(D)</sub>  | Common-mode output voltage (Dominant)     | See <a href="#">图 14</a>  |      | 2     | 2.3  | 3     | V     |
| V <sub>OC(pp)</sub> | Peak-to-peak common-mode output voltage   |   |      |       | 0.3  |       |       |
| I <sub>IH</sub>     | High-level input current, TXD input       | V <sub>I</sub> at 2 V   |      |       |      | 5     | μA    |
| I <sub>IL</sub>     | Low-level input current, TXD input        | V <sub>I</sub> at 0.8 V   |      | -5    |      |       | μA    |
| I <sub>O(off)</sub> | Power-off TXD leakage current             | V <sub>CC1</sub> , V <sub>CC2</sub> at 0 V, TXD at 5 V  |      |       |      | 10    | μA    |
| I <sub>OS(ss)</sub> | Short-circuit steady-state output current | See <a href="#">图 17</a> , V <sub>CANH</sub> = -12 V, CANL Open   |      | -105  |      | -72   | mA    |
|                     |   | See <a href="#">图 17</a> , V <sub>CANH</sub> = 12 V, CANL Open  |      |       | 0.36 | 1     |       |
|                     |   | See <a href="#">图 17</a> , V <sub>CANL</sub> = -12 V, CANH Open   |      | -1    |      | -0.5  |       |
|                     |   | See <a href="#">图 17</a> , V <sub>CANL</sub> = 12 V, CANH Open  |      |       | 71   | 105   |       |
| C <sub>O</sub>      | Output capacitance                        | See receiver input capacitance  |      |       |      |       |       |
| CMTI                | Common-mode transient immunity            | See <a href="#">图 19</a> , V <sub>I</sub> = V <sub>CC</sub> or 0 V  |      | 25    | 50   |       | kV/μs |

### 6.7 Electrical Characteristics: Receiver

over recommended operating conditions (unless otherwise noted)

| PARAMETER         |  | TEST CONDITIONS                                      | MIN                   | TYP <sup>(1)</sup> | MAX | UNIT  |
|-------------------|--|--|-----------------------|--------------------|-----|-------|
| V <sub>IT+</sub>  | Positive-going bus input threshold voltage   | See 表 1  |                       | 750                | 900 | mV    |
| V <sub>IT-</sub>  | Negative-going bus input threshold voltage   |  | 500                   | 650                | mV  |       |
| V <sub>hys</sub>  | Hysteresis voltage (V <sub>IT+</sub> – V <sub>IT-</sub> )                                    |  | 150                   | mV                 |     |       |
| V <sub>OH</sub>   | High-level output voltage with V <sub>CC</sub> = 5 V   | I <sub>OH</sub> = –4 mA, See 图 12                    | V <sub>CC</sub> – 0.8 | 4.6                | V   |       |
|                   |  | I <sub>OH</sub> = –20 μA, See 图 12                   | V <sub>CC</sub> – 0.1 | 5                  |     |       |
| V <sub>OH</sub>   | High-level output voltage with V <sub>CC1</sub> = 3.3 V                                      | I <sub>OL</sub> = 4 mA, See 图 12                     | V <sub>CC</sub> – 0.8 | 3.1                | V   |       |
|                   |  | I <sub>OL</sub> = 20 μA, See 图 12                    | V <sub>CC</sub> – 0.1 | 3.3                |     |       |
| V <sub>OL</sub>   | Low-level output voltage   | I <sub>OL</sub> = 4 mA, See 图 12                     |                       | 0.2                | 0.4 | V     |
|                   |  | I <sub>OL</sub> = 20 μA, See 图 12                    |                       | 0                  | 0.1 |       |
| C <sub>I</sub>    | Input capacitance to ground, (CANH or CANL)  | TXD at 3 V, V <sub>I</sub> = 0.4 sin (4E6πt) + 2.5 V |                       | 6                  |     | pF    |
| C <sub>ID</sub>   | Differential input capacitance   | TXD at 3 V, V <sub>I</sub> = 0.4 sin (4E6πt)         |                       | 3                  |     | pF    |
| R <sub>ID</sub>   | Differential input resistance  | TXD at 3 V   | 30                    |                    | 80  | kΩ    |
| R <sub>IN</sub>   | Input resistance (CANH or CANL)  | TXD at 3 V   | 15                    | 30                 | 40  | kΩ    |
| R <sub>I(m)</sub> | Input resistance matching<br>(1 – [R <sub>IN (CANH)</sub> / R <sub>IN (CANL)</sub> ]) × 100% | V <sub>CANH</sub> = V <sub>CANL</sub>                | –3%                   | 0%                 | 3%  |       |
| CMTI              | Common-mode transient immunity   | V <sub>I</sub> = V <sub>CC</sub> or 0 V, See 图 19    | 25                    | 50                 |     | kV/μs |

(1) All typical values are at 25°C with V<sub>CC1</sub> = V<sub>CC2</sub> = 5 V.

### 6.8 Switching Characteristics: Device

over recommended operating conditions (unless otherwise noted)

| PARAMETER          |  | TEST CONDITIONS | MIN | TYP | MAX | UNIT |
|--------------------|--|-----------------|-----|-----|-----|------|
| t <sub>loop1</sub> | Total loop delay, driver input to receiver output, Recessive to Dominant | See 图 15        | 112 | 150 | 210 | ns   |
| t <sub>loop2</sub> | Total loop delay, driver input to receiver output, Dominant to Recessive | See 图 15        | 112 | 150 | 210 | ns   |

### 6.9 Switching Characteristics: Driver

over recommended operating conditions (unless otherwise noted)

| PARAMETER                           |  | TEST CONDITIONS                    | MIN | TYP | MAX | UNIT |
|-------------------------------------|--|------------------------------------|-----|-----|-----|------|
| t <sub>PLH</sub>                    | Propagation delay time, recessive-to-dominant output | See 图 10                           | 31  | 74  | 110 | ns   |
| t <sub>PHL</sub>                    | Propagation delay time, dominant-to-recessive output |                                    | 25  | 44  | 75  |      |
| t <sub>r</sub>                      | Differential output signal rise time                 |                                    | 20  | 50  |     |      |
| t <sub>f</sub>                      | Differential output signal fall time                 |                                    | 20  | 50  |     |      |
| t <sub>TXD_DTO</sub> <sup>(1)</sup> | Dominant time-out                                    | ↓ C <sub>L</sub> =100 pF, See 图 16 | 300 | 450 | 700 | μs   |

(1) The TXD dominant time out (t<sub>TXD\_DTO</sub>) disables the driver of the transceiver once the TXD has been dominant longer than (t<sub>TXD\_DTO</sub>) which releases the bus lines to recessive preventing a local failure from locking the bus dominant. The driver may only transmit dominant again after TXD has been returned HIGH (recessive). While this protects the bus from local faults locking the bus dominant it limits the minimum data rate possible. The CAN protocol allows a maximum of eleven successive dominant bits (on TXD) for the worst case where five successive dominant bits are followed immediately by an error frame. This along with the (t<sub>TXD\_DTO</sub>) minimum limits the minimum bit rate. The minimum bit rate may be calculated by: Minimum Bit Rate = 11/ (t<sub>TXD\_DTO</sub>) = 11 bits / 300 μs = 37 kbps.

### 6.10 Switching Characteristics: Receiver

over recommended operating conditions (unless otherwise noted)

| PARAMETER |  | TEST CONDITIONS       | MIN | TYP | MAX | UNIT    |
|-----------|--|-----------------------|-----|-----|-----|---------|
| $t_{PLH}$ | Propagation delay time, low-to-high-level output     | TXD at 3 V, See 图 12  | 66  | 90  | 130 | ns      |
| $t_{PHL}$ | Propagation delay time, high-to-low-level output     |                       | 51  | 80  | 105 |         |
| $t_r$     | Output signal rise time                              |                       |     | 3   | 6   |         |
| $t_f$     | Output signal fall time                              |                       |     | 3   | 6   |         |
| $t_{fs}$  | Fail-Safe output delay time from bus-side power loss | VCC1 at 5 V, See 图 18 |     | 6   |     | $\mu$ s |

### 6.11 Typical Characteristics

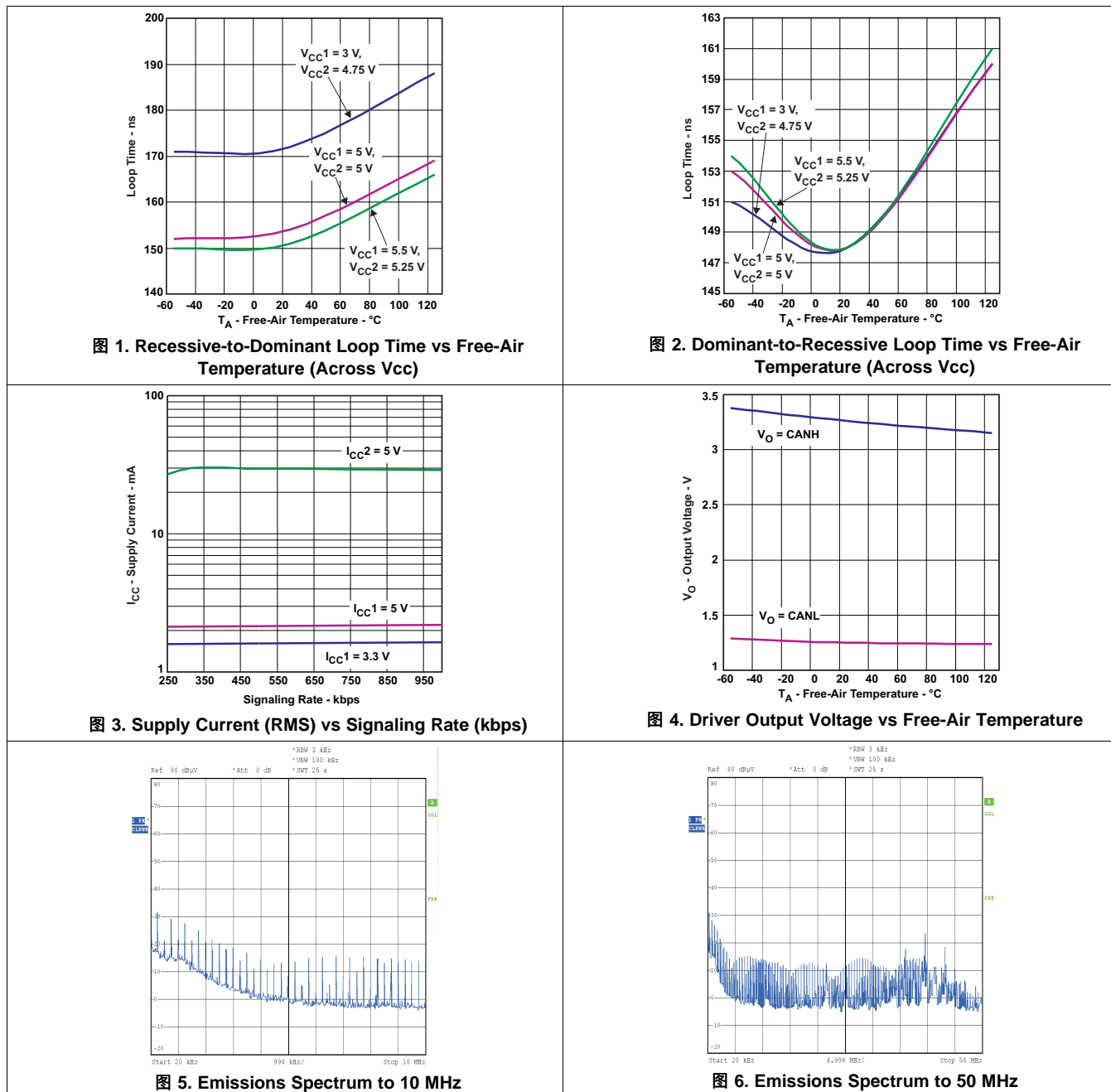

## 7 Parameter Measurement Information



图 7. Driver Voltage, Current and Test Definitions



图 8. Bus Logic State Voltage Definitions

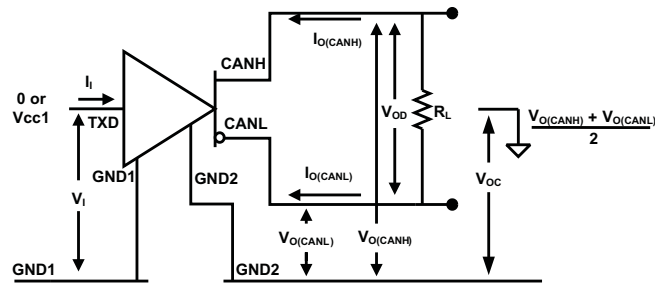

图 9. Driver  $V_{OD}$  With Common-Mode Loading Test Circuit

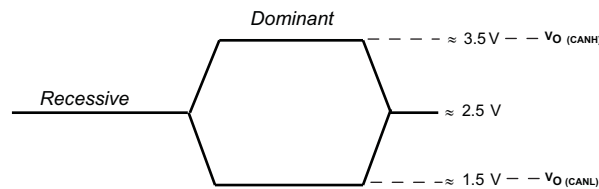

- A. The input pulse is supplied by a generator having the following characteristics: PRR  $\leq$  125 kHz, 50% duty cycle,  $t_r \leq$  6 ns,  $t_f \leq$  6 ns,  $Z_O = 50 \Omega$ .
- B.  $C_L$  includes instrumentation and fixture capacitance within  $\pm 20\%$ .

图 10. Driver Test Circuit and Voltage Waveforms

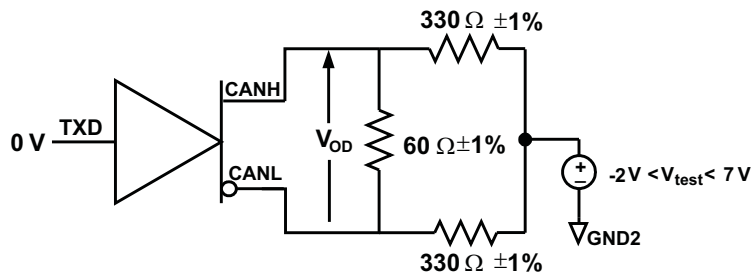
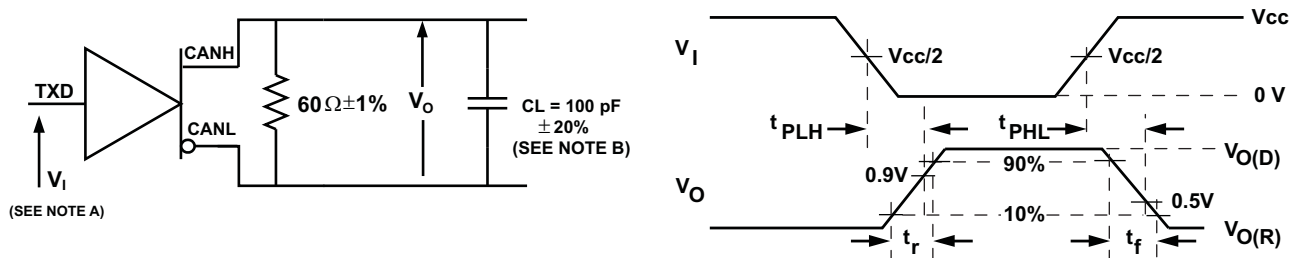
Parameter Measurement Information (接下页)



图 11. Receiver Voltage and Current Definitions



- A. The input pulse is supplied by a generator having the following characteristics: PRR ≤ 125 kHz, 50% duty cycle,  $t_r \leq 6$  ns,  $t_f \leq 6$  ns,  $Z_O = 50 \Omega$ .
- B.  $C_L$  includes instrumentation and fixture capacitance within ±20%.

图 12. Receiver Test Circuit and Voltage Waveforms

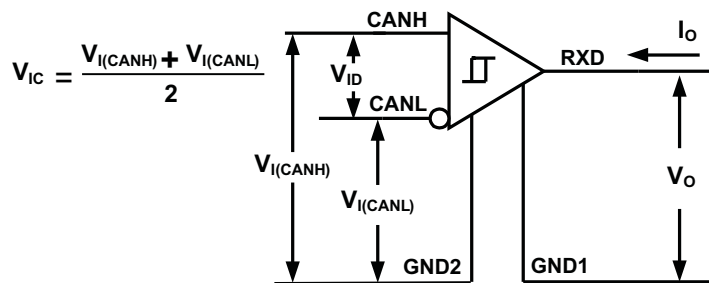
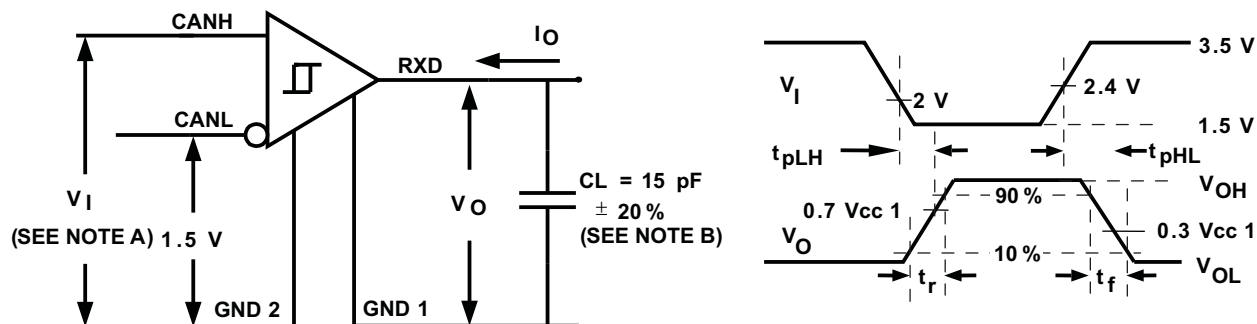
表 1. Differential Input Voltage Threshold Test

| INPUT      |            |            | OUTPUT |          |
|------------|------------|------------|--------|----------|
| $V_{CANH}$ | $V_{CANL}$ | $ V_{ID} $ | R      |          |
| -11.1 V    | -12 V      | 900 mV     | L      | $V_{OL}$ |
| 12 V       | 11.1 V     | 900 mV     | L      |          |
| -6 V       | -12 V      | 6 V        | L      |          |
| 12 V       | 6 V        | 6 V        | L      |          |
| -11.5 V    | -12 V      | 500 mV     | H      | $V_{OH}$ |
| 12 V       | 11.5 V     | 500 mV     | H      |          |
| -12 V      | -6 V       | -6 V       | H      |          |
| 6 V        | 12 V       | -6 V       | H      |          |
| Open       | Open       | X          | H      |          |

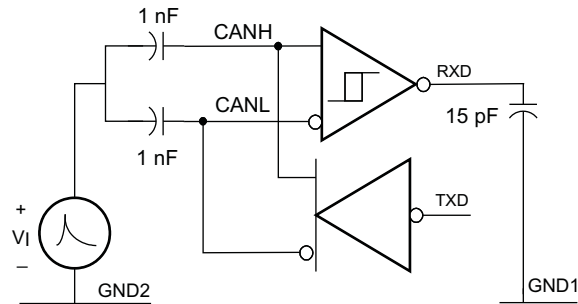

The waveforms of the applied transients are in accordance with ISO 7637 part 1, test pulses 1, 2, 3a, and 3b.

图 13. Transient Overvoltage Test Circuit



图 14. Peak-to-Peak Output Voltage Test Circuit and Waveform



图 15.  $t_{\text{LOOP}}$  Test Circuit and Voltage Waveforms

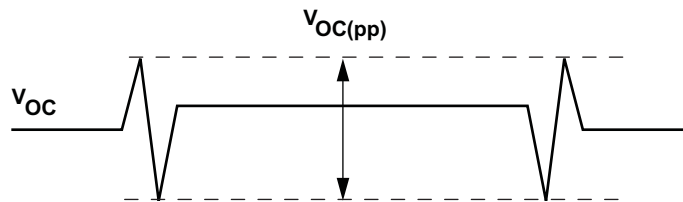
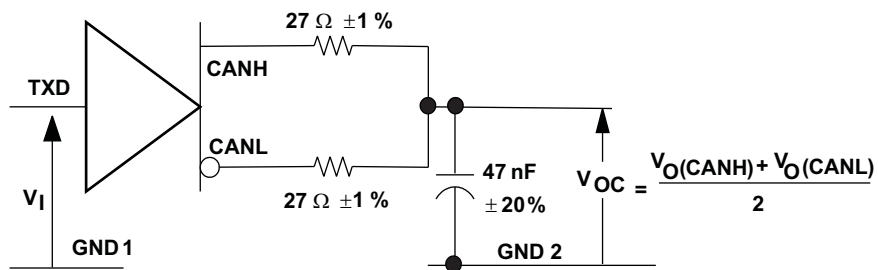

- A. The input pulse is supplied by a generator having the following characteristics:  $t_r \leq 6 \text{ ns}$ ,  $t_f \leq 6 \text{ ns}$ ,  $Z_o = 50 \Omega$ .
- B.  $C_L$  includes instrumentation and fixture capacitance within  $\pm 20\%$ .

图 16. Dominant Time-out Test Circuit and Voltage Waveforms

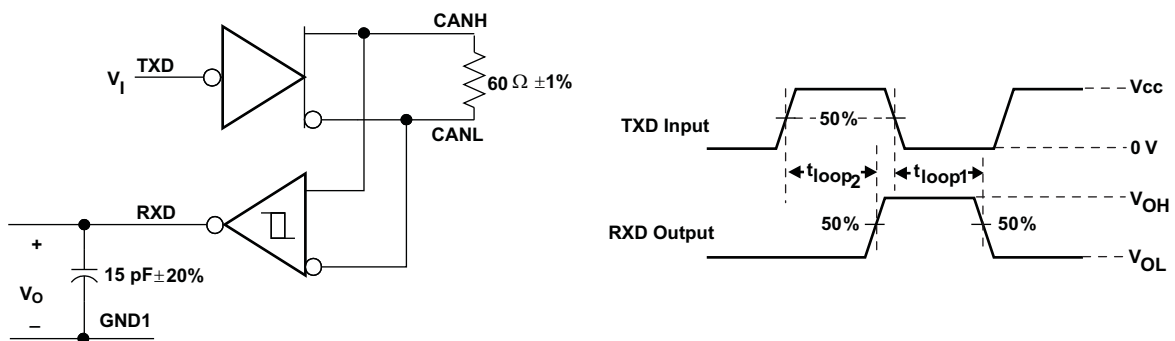
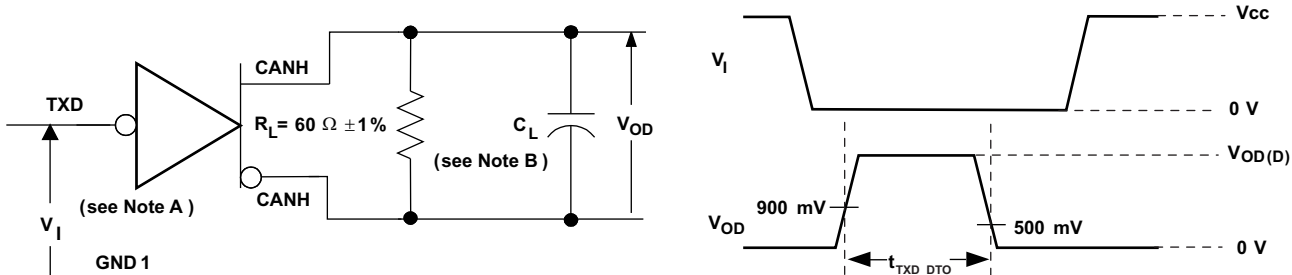

图 17. Driver Short-Circuit Current Test Circuit and Waveforms



图 18. Fail-Safe Delay Time Test Circuit and Voltage Waveforms

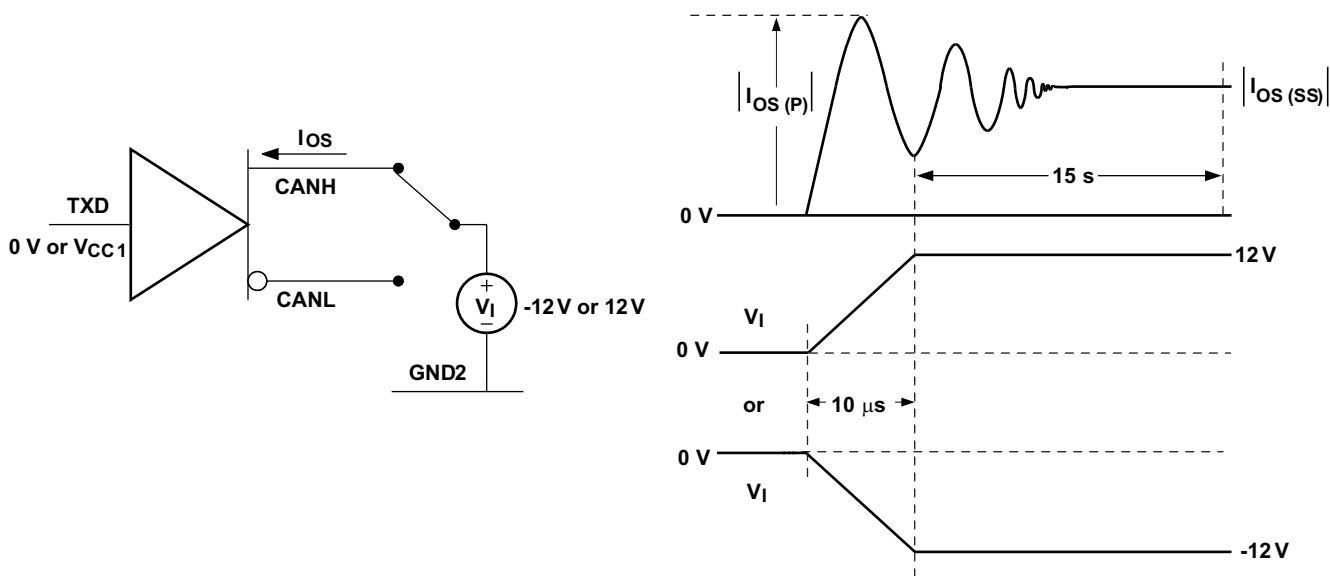

图 19. Common-Mode Transient Immunity Test Circuit

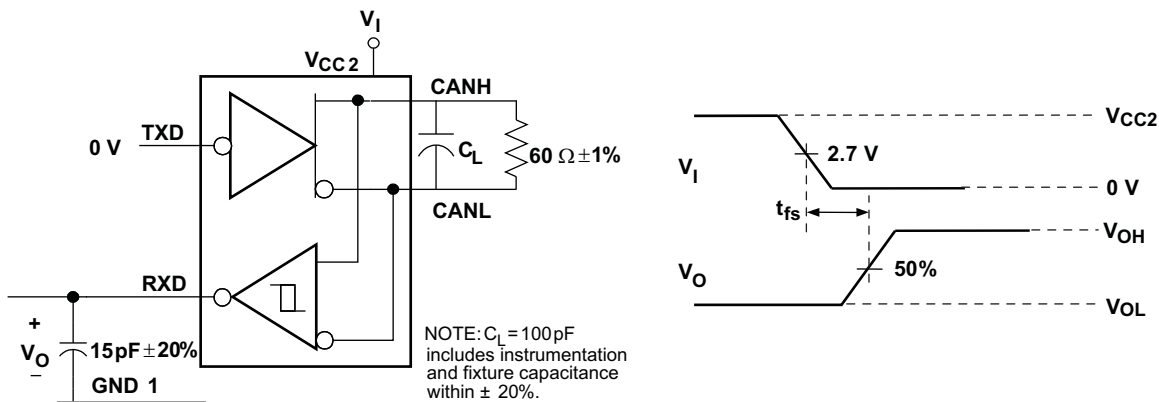

图 20. Electromagnetic Emissions Measurement Setup

## 8 Detailed Description

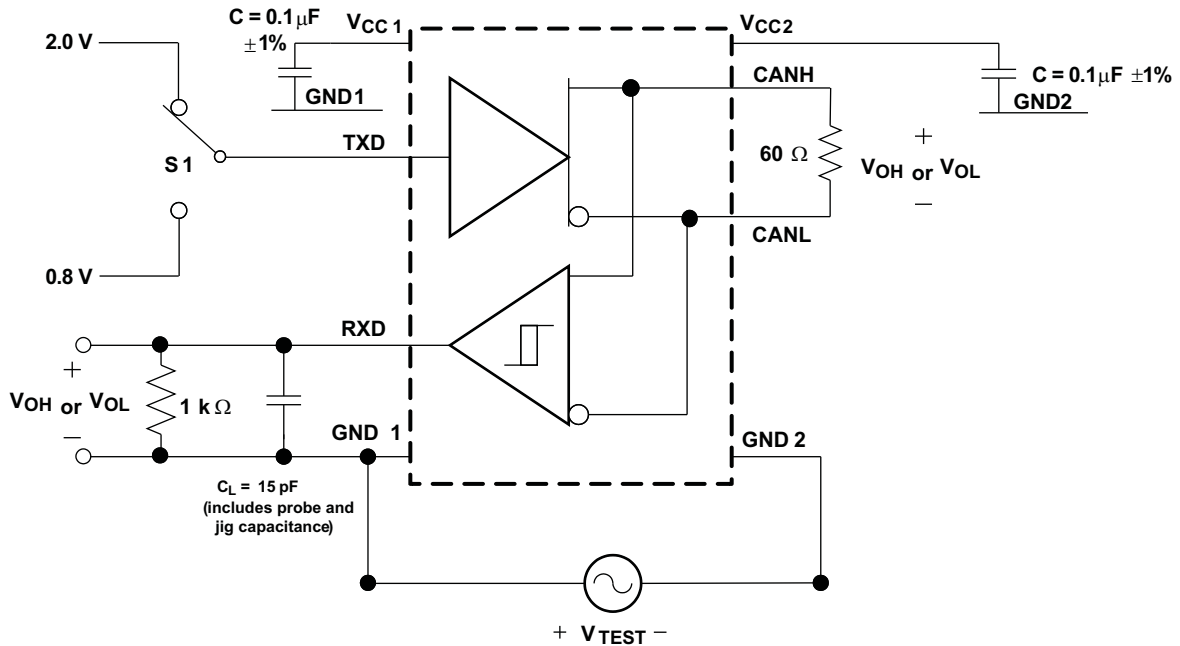
### 8.1 Overview

The ISO1050 is a digitally isolated CAN transceiver with a typical transient immunity of 50 kV/μs. The device can operate from 3.3-V supply on side 1 and 5-V supply on side 2. This is of particular advantage for applications operating in harsh industrial environments because the 3.3 V on side 1 enables the connection to low-volt microcontrollers for power preservation, whereas the 5 V on side 2 maintains a high signal-to-noise ratio of the bus signals.

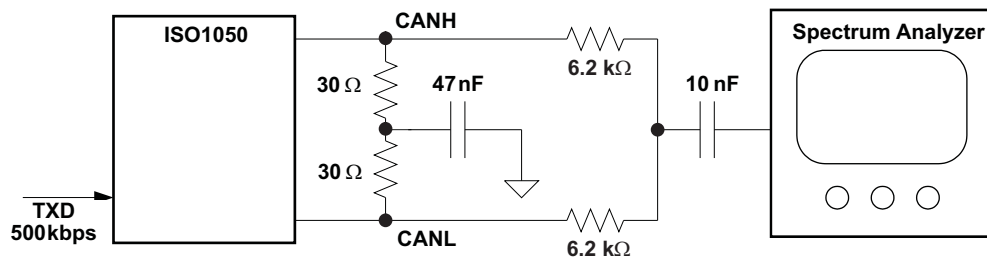
### 8.2 Functional Block Diagram

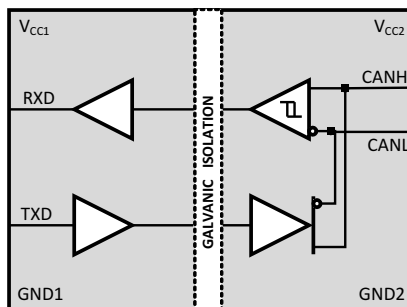

### 8.3 Feature Description

表 2. Isolator Characteristics<sup>(1)(2)</sup>

| PARAMETER       |   | TEST CONDITIONS   | MIN   | TYP               | MAX | UNIT |
|-----------------|---|---|-------|-------------------|-----|------|
| L(I01)          | Minimum air gap (Clearance)               | Shortest pin-to-pin distance through air, per JEDEC package dimensions  | 6.1   |                   |     | mm   |
| L(I02)          | Minimum external tracking (Creepage)      | Shortest pin-to-pin distance across the package surface, per JEDEC package dimensions   |       |                   |     |      |
| L(I01)          | Minimum air gap (Clearance)               | Shortest pin-to-pin distance through air, per JEDEC package dimensions  | 8.34  |                   |     | mm   |
| L(I02)          | Minimum external tracking (Creepage)      | Shortest pin-to-pin distance across the package surface, per JEDEC package dimensions   |       |                   |     |      |
|                 | Minimum Internal Gap (Internal Clearance) | Distance through the insulation   | 0.014 |                   |     | mm   |
| R <sub>IO</sub> | Isolation resistance                      | Input to output, V <sub>IO</sub> = 500 V, all pins on each side of the barrier tied together creating a two-pin device, T <sub>A</sub> = 25°C |       | >10 <sup>12</sup> |     | Ω    |
|                 |   | Input to output, V <sub>IO</sub> = 500 V, 100°C ≤ T <sub>A</sub> ≤ T <sub>A</sub> max   |       | >10 <sup>11</sup> |     | Ω    |
| C <sub>IO</sub> | Barrier capacitance                       | V <sub>I</sub> = 0.4 sin (4E6πt)  |       | 1.9               |     | pF   |
| C <sub>I</sub>  | Input capacitance to ground               | V <sub>I</sub> = 0.4 sin (4E6πt)  |       | 1.3               |     | pF   |

- (1) Creepage and clearance requirements should be applied according to the specific equipment isolation standards of an application. Care should be taken to maintain the creepage and clearance distance of a board design to ensure that the mounting pads of the isolator on the printed-circuit-board do not reduce this distance.
- (2) Creepage and clearance on a printed-circuit-board become equal according to the measurement techniques shown in the Isolation Glossary. Techniques such as inserting grooves and/or ribs on a printed-circuit-board are used to help increase these specifications.

**表 3. Insulation Characteristics**

| PARAMETER         |  | TEST CONDITIONS                           | SPECIFICATION   | UNIT              |                  |
|-------------------|--|---|---|-------------------|------------------|
| V <sub>IORM</sub> | Maximum working insulation voltage per DIN V VDE V 0884-10 (VDE V 0884-10):2006-12 | ISO1050DUB                                | 560   | V <sub>peak</sub> |                  |
|                   |  | ISO1050DW                                 | 1200  |                   |                  |
| V <sub>PR</sub>   | Input to output test voltage per DIN V VDE V 0884-10 (VDE V 0884-10):2006-12       | ISO1050DUB                                | V <sub>PR</sub> = 1.875 × V <sub>IORM</sub> , t = 1 sec (100% production)<br>Partial discharge < 5 pC | 1050              |                  |
|                   |  | ISO1050DW                                 |   | 2250              |                  |
| V <sub>IOTM</sub> | Transient overvoltage per DIN V VDE V 0884-10 (VDE V 0884-10):2006-12              | t = 60 sec (qualification)                | 4000  | V <sub>peak</sub> |                  |
|                   |  | t = 1 sec (100% production)               |   |                   |                  |
| V <sub>ISO</sub>  | Isolation voltage per UL 1577  | ISO1050DUB - Double Protection            | t = 60 sec (qualification)  | 2500              | V <sub>rms</sub> |
|                   |  |   | t = 1 sec (100% production)   | 3000              |                  |
|                   |  | ISO1050DW - Single Protection             | t = 60 sec (qualification)  | 4243              | V <sub>rms</sub> |
|                   |  |   | t = 1 sec (100% production)   | 5092              |                  |
| R <sub>S</sub>    | Isolation resistance   | V <sub>IO</sub> = 500 V at T <sub>S</sub> | > 10 <sup>9</sup>   | Ω                 |                  |
|                   | Pollution Degree   |   | 2   |                   |                  |

**表 4. IEC 60664-1 Ratings**

| PARAMETER                   | TEST CONDITIONS   | SPECIFICATION |
|-----------------------------|---|---------------|
| Basic isolation group       | Material group  | II            |
| Installation classification | Rated mains voltage ≤ 150 V <sub>rms</sub>                  | I–IV          |
|                             | Rated mains voltage ≤ 300 V <sub>rms</sub>                  | I–III         |
|                             | Rated mains voltage ≤ 400 V <sub>rms</sub>                  | I–II          |
|                             | Rated mains voltage ≤ 600 V <sub>rms</sub> (ISO1050DW only) | I–II          |
|                             | Rated mains voltage ≤ 848 V <sub>rms</sub> (ISO1050DW only) | I             |

**表 5. IEC Safety Limiting Values<sup>(1)</sup>**

| PARAMETER  | TEST CONDITIONS  | MIN  | TYP  | MAX  | UNIT |
|--|--|--|--|--|------|
|  |  | I <sub>S</sub> Safety input, output, or supply current | DUB-8  | θ <sub>JA</sub> = 73.3 °C/W, V <sub>I</sub> = 5.5 V, T <sub>J</sub> = 150°C, T <sub>A</sub> = 25°C |      |
| θ <sub>JA</sub> = 73.3 °C/W, V <sub>I</sub> = 3.6 V, T <sub>J</sub> = 150°C, T <sub>A</sub> = 25°C |  |  |  |  | 474  |
| DW-16  | θ <sub>JA</sub> = 76 °C/W, V <sub>I</sub> = 5.5 V, T <sub>J</sub> = 150°C, T <sub>A</sub> = 25°C |  |  | 299  | mA   |
|  |  |  | θ <sub>JA</sub> = 76 °C/W, V <sub>I</sub> = 3.6 V, T <sub>J</sub> = 150°C, T <sub>A</sub> = 25°C |  |      |
| T <sub>S</sub> Maximum case temperature  |  |  |  | 150  | °C   |

(1) Safety limiting intends to prevent potential damage to the isolation barrier upon failure of input or output circuitry. A failure of the I/O can allow low resistance to ground or the supply and, without current limiting dissipate sufficient power to overheat the die and damage the isolation barrier potentially leading to secondary system failures.

The safety-limiting constraint is the absolute maximum junction temperature specified in the absolute maximum ratings table. The power dissipation and junction-to-air thermal impedance of the device installed in the application hardware determines the junction temperature. The assured junction-to-air thermal resistance in [Thermal Information](#) is that of a device installed on a High-K Test Board for Leaded Surface Mount Packages. The power is the recommended maximum input voltage times the current. The junction temperature is then the ambient temperature plus the power times the junction-to-air thermal resistance.



图 21. DUB-8  $\theta_{JC}$  Thermal Derating Curve per VDE

图 22. DW-16  $\theta_{JC}$  Thermal Derating Curve per VDE

表 6. Regulatory Information

| VDE  | TUV   | CSA  | UL   | CQC   |
|--|---|--|--|---|
| Certified according to DIN V VDE V 0884-10 (VDE V 0884-10):2006-12 & DIN EN 61010-1  | Certified according to EN/UL/CSA 60950-1  | Approved under CSA Component Acceptance Notice 5A  | Recognized under 1577 Component Recognition Program <sup>(1)</sup>   | Certified according to GB4943.1-2011  |
| Basic Insulation<br>Transient Overvoltage, 4000 V <sub>PK</sub><br>Surge Voltage, 4000 V <sub>PK</sub><br>Maximum Working Voltage, 1200 V <sub>PK</sub> (ISO1050DW) and 560 V <sub>PK</sub> (ISO1050DUB) | <b>ISO1050DW:</b><br>5000 V <sub>RMS</sub> Reinforced Insulation, 400 V <sub>RMS</sub> maximum working voltage<br>5000 V <sub>RMS</sub> Basic Insulation, 600 V <sub>RMS</sub> maximum working voltage<br><b>ISO1050DUB:</b><br>2500 V <sub>RMS</sub> Reinforced Insulation, 400 V <sub>RMS</sub> maximum working voltage<br>2500 V <sub>RMS</sub> Basic Insulation, 600 V <sub>RMS</sub> maximum working voltage | 5000 V <sub>RMS</sub> Reinforced Insulation<br>2 Means of Patient Protection at 125 V <sub>RMS</sub> per IEC 60601-1 (3rd Ed.) | ISO1050DUB: 2500 V <sub>RMS</sub> Double Protection<br>ISO1050DW: 3500 V <sub>RMS</sub> Double Protection, 4243 V <sub>RMS</sub> Single Protection | <b>ISO1050DW:</b><br>Reinforced Insulation, Altitude ≤ 5000 m, Tropical Climate, 250 V <sub>RMS</sub> maximum working voltage |
| Certificate number: 40016131   | Certificate number: U8V 11 09 77311 008   | Master contract number: 220991   | File number: E181974   | Certificate number: CQC14001109541  |

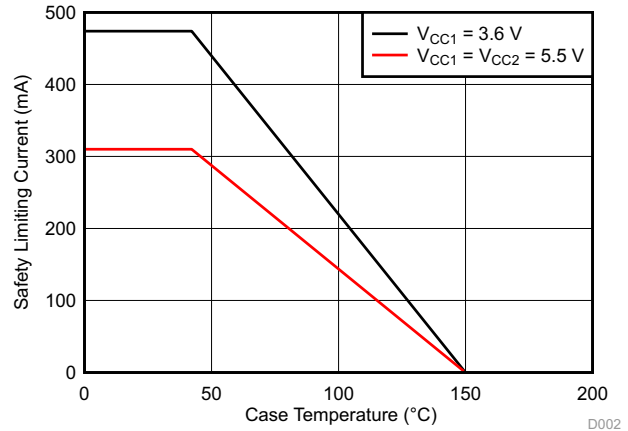
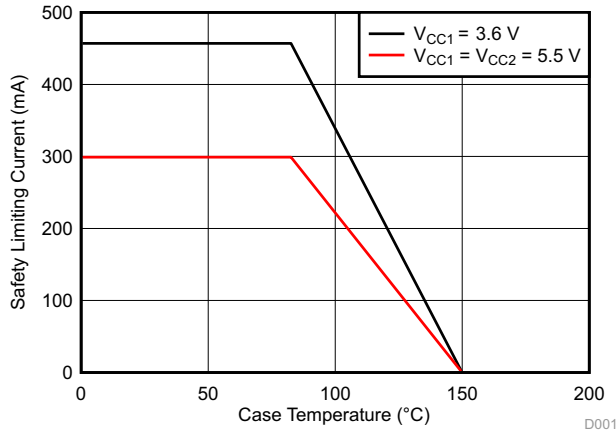
(1) Production tested ≥ 3000 V<sub>RMS</sub> (ISO1050DUB) and 5092 V<sub>RMS</sub> (ISO1050DW) for 1 second in accordance with UL 1577.

### 8.3.1 CAN Bus States

The CAN bus has two states during operation: *dominant* and *recessive*. A dominant bus state, equivalent to logic low, is when the bus is driven differentially by a driver. A recessive bus state is when the bus is biased to a common mode of  $V_{CC} / 2$  through the high-resistance internal input resistors of the receiver, equivalent to a logic high. The host microprocessor of the CAN node will use the TXD pin to drive the bus and will receive data from the bus on the RXD pin. See 图 23 and 图 24.

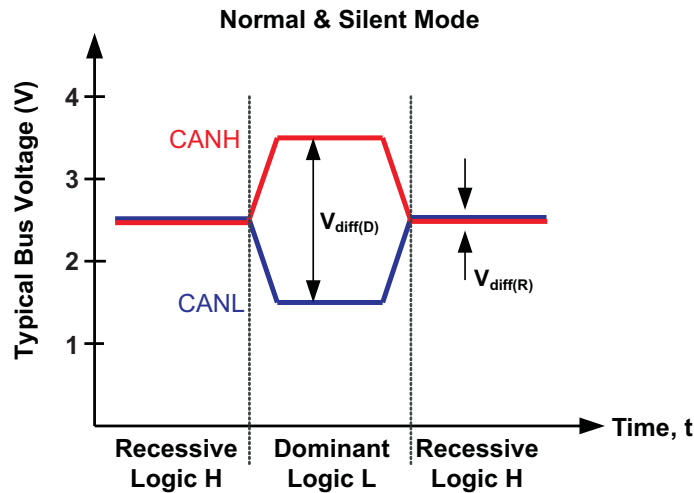
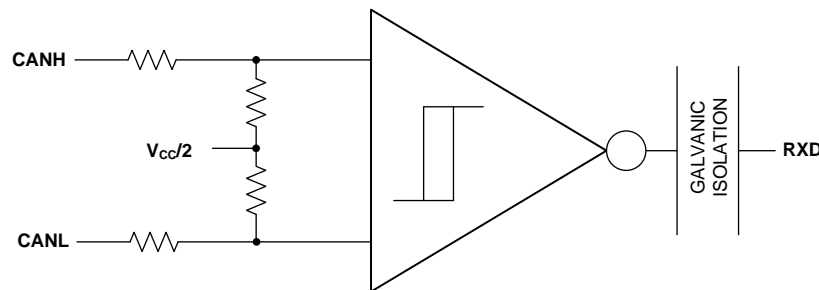
**图 23. Bus States (Physical Bit Representation)**

**图 24. Simplified Recessive Common Mode Bias and Receiver**

### 8.3.2 Digital Inputs and Outputs

#### TXD (Input) and RXD (Output):

$V_{CC1}$  for the isolated digital input and output side of the device maybe supplied by a 3.3-V or 5-V supply and thus the digital inputs and outputs are 3.3-V and 5-V compatible.

#### 注

TXD is very weakly internally pulled up to  $V_{CC1}$ . An external pullup resistor should be used to make sure that TXD is biased to recessive (high) level to avoid issues on the bus if the microprocessor doesn't control the pin and TXD floats. TXD pullup strength and CAN bit timing require special consideration when the device is used with an open-drain TXD output on the CAN controller of the microprocessor. An adequate external pullup resistor must be used to ensure that the TXD output of the microprocessor maintains adequate bit timing input to the input on the transceiver.

### 8.3.3 Protection Features

#### 8.3.3.1 TXD Dominant Time-Out (DTO)

TXD DTO circuit prevents the local node from blocking network communication in the event of a hardware or software failure where TXD is held dominant longer than the time-out period  $t_{TXD\_DTO}$ . The TXD DTO circuit timer starts on a falling edge on TXD. The TXD DTO circuit disables the CAN bus driver if no rising edge is seen before the time-out period expires. This frees the bus for communication between other nodes on the network. The CAN driver is re-activated when a recessive signal is seen on the TXD pin, thus clearing the TXD DTO condition. The receiver and RXD pin still reflect the CAN bus, and the bus pins are biased to recessive level during a TXD dominant time-out.

注

The minimum dominant TXD time allowed by the TXD DTO circuit limits the minimum possible transmitted data rate of the device. The CAN protocol allows a maximum of eleven successive dominant bits (on TXD) for the worst case, where five successive dominant bits are followed immediately by an error frame. This, along with the  $t_{TXD\_DTO}$  minimum, limits the minimum data rate. Calculate the minimum transmitted data rate by: Minimum Data Rate =  $11 / t_{TXD\_DTO}$ .



图 25. Example Timing Diagram for Devices With TXD DTO

8.3.3.2 Thermal Shutdown

If the junction temperature of the device exceeds the thermal shut down threshold the device turns off the CAN driver circuits thus blocking the TXD to bus transmission path. The shutdown condition is cleared when the junction temperature drops below the thermal shutdown temperature of the device. If the fault condition is still present, the temperature may rise again and the device would enter thermal shut down again. Prolonged operation with thermal shutdown conditions may affect device reliability.

注

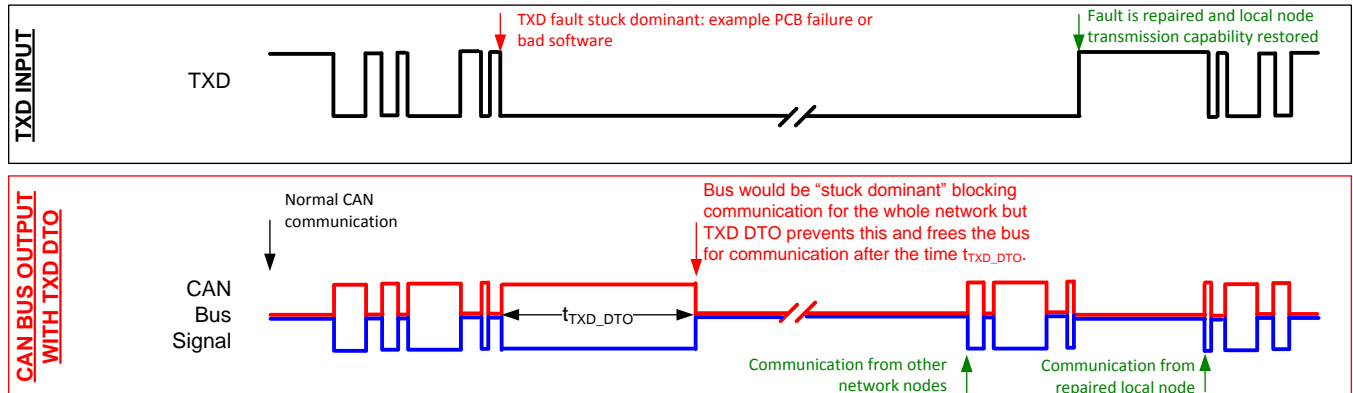
During thermal shutdown the CAN bus drivers turn off; thus no transmission is possible from TXD to the bus. The CAN bus pins are biased to recessive level during a thermal shutdown, and the receiver to RXD path remains operational.

8.3.3.3 Undervoltage Lockout and Fail-Safe

The supply pins have undervoltage detection that places the device in protected or fail-safe mode. This protects the bus during an undervoltage event on  $V_{CC1}$  or  $V_{CC2}$  supply pins. If the bus-side power supply  $V_{CC2}$  is lower than about 2.7V, the power shutdown circuits in the ISO1050 will disable the transceiver to prevent false transmissions due to an unstable supply. If  $V_{CC1}$  is still active when this occurs, the receiver output (RXD) will go to a fail-safe HIGH (recessive) value in about 6 microseconds.

表 7. Undervoltage Lockout and Fail-Safe

| $V_{CC1}$ | $V_{CC2}$ | DEVICE STATE | BUS OUTPUT               | RXD                        |
|-----------|-----------|--------------|--------------------------|----------------------------|
| GOOD      | GOOD      | Functional   | Per Device State and TXD | Mirrors Bus                |
| BAD       | GOOD      | Protected    | Recessive                | High Impedance (3-state)   |
| GOOD      | BAD       | Protected    | High Impedance           | Recessive (Fail-Safe High) |

注

After an undervoltage condition is cleared and the supplies have returned to valid levels, the device typically resumes normal operation in 300  $\mu$ s

### 8.3.3.4 Floating Pins

Pullups and pulldowns should be used on critical pins to place the device into known states if the pins float. The TXD pin should be pulled up through a resistor to  $V_{CC1}$  to force a recessive input level if the microprocessor output to the pin floats.

### 8.3.3.5 CAN Bus Short-Circuit Current Limiting

The device has several protection features that limit the short-circuit current when a CAN bus line is shorted. These include driver current limiting (dominant and recessive). The device has TXD dominant state time out to prevent permanent higher short-circuit current of the dominant state during a system fault. During CAN communication the bus switches between dominant and recessive states with the data and control fields bits, thus the short-circuit current may be viewed either as the instantaneous current during each bus state, or as a DC average current. For system current (power supply) and power considerations in the termination resistors and common-mode choke ratings, use the average short-circuit current. Determine the ratio of dominant and recessive bits by the data in the CAN frame plus the following factors of the protocol and PHY that force either recessive or dominant at certain times:

- Control fields with set bits
- Bit-stuffing
- Interframe space
- TXD dominant time-out (fault case limiting)

These ensure a minimum recessive amount of time on the bus even if the data field contains a high percentage of dominant bits.

#### 注

The short-circuit current of the bus depends on the ratio of recessive to dominant bits and their respective short-circuit currents. The average short-circuit current may be calculated with the following formula:

$$I_{OS(AVG)} = \%Transmit \times [(\%REC\_Bits \times I_{OS(SS)\_REC}) + (\%DOM\_Bits \times I_{OS(SS)\_DOM})] + [\%Receive \times I_{OS(SS)\_REC}]$$

Where

- $I_{OS(AVG)}$  is the average short-circuit current.
- %Transmit is the percentage the node is transmitting CAN messages.
- %Receive is the percentage the node is receiving CAN messages.
- %REC\_Bits is the percentage of recessive bits in the transmitted CAN messages.
- %DOM\_Bits is the percentage of dominant bits in the transmitted CAN messages.
- $I_{OS(SS)\_REC}$  is the recessive steady state short-circuit current.
- $I_{OS(SS)\_DOM}$  is the dominant steady state short-circuit current.

#### 注

Consider the short.circuit current and possible fault cases of the network when sizing the power ratings of the termination resistance and other network components.

## 8.4 Device Functional Modes

表 8. Driver Function Table

| INPUT              | OUTPUTS             |                     | DRIVEN BUS STATE |
|--------------------|---------------------|---------------------|------------------|
|                    | CANH <sup>(1)</sup> | CANL <sup>(1)</sup> |                  |
| TXD <sup>(1)</sup> |                     |                     |                  |
| L                  | H                   | L                   | Dominant         |
| H                  | Z                   | Z                   | Recessive        |

(1) H = high level, L = low level, Z = common mode (recessive) bias to  $V_{CC} / 2$ . See 图 23 and 图 24 for bus state and common mode bias information.

表 9. Receiver Function Table

| DEVICE MODE      | CAN DIFFERENTIAL INPUTS<br>$V_{ID} = V_{CANH} - V_{CANL}$ | BUS STATE | RXD PIN <sup>(1)</sup> |
|------------------|---|-----------|------------------------|
| Normal or Silent | $V_{ID} \geq 0.9\text{ V}$                                | Dominant  | L                      |
|                  | $0.5\text{ V} < V_{ID} < 0.9\text{ V}$                    | ?         | ?                      |
|                  | $V_{ID} \leq 0.5\text{ V}$                                | Recessive | H                      |
|                  | Open ( $V_{ID} \approx 0\text{ V}$ )                      | Open      | H                      |

(1) H = high level, L = low level, ? = indeterminate.

表 10. Function Table<sup>(1)</sup>

| DRIVER           |         |      | RECEIVER  |   |            |           |
|------------------|---------|------|-----------|---|------------|-----------|
| INPUTS           | OUTPUTS |      | BUS STATE | DIFFERENTIAL INPUTS<br>$V_{ID} = CANH - CANL$ | OUTPUT RXD | BUS STATE |
| TXD              | CANH    | CANL |           |   |            |           |
| L <sup>(2)</sup> | H       | L    | DOMINANT  | $V_{ID} \geq 0.9\text{ V}$                    | L          | DOMINANT  |
| H                | Z       | Z    | RECESSIVE | $0.5\text{ V} < V_{ID} < 0.9\text{ V}$        | ?          | ?         |
| Open             | Z       | Z    | RECESSIVE | $V_{ID} \leq 0.5\text{ V}$                    | H          | RECESSIVE |
| X                | Z       | Z    | RECESSIVE | Open  | H          | RECESSIVE |

(1) H = high level; L = low level; X = irrelevant; ? = indeterminate; Z = high impedance

(2) Logic low pulses to prevent dominant time-out.



图 26. Equivalent I/O Schematics

## 9 Application and Implementation

注

Information in the following applications sections is not part of the TI component specification, and TI does not warrant its accuracy or completeness. TI's customers are responsible for determining suitability of components for their purposes. Customers should validate and test their design implementation to confirm system functionality.

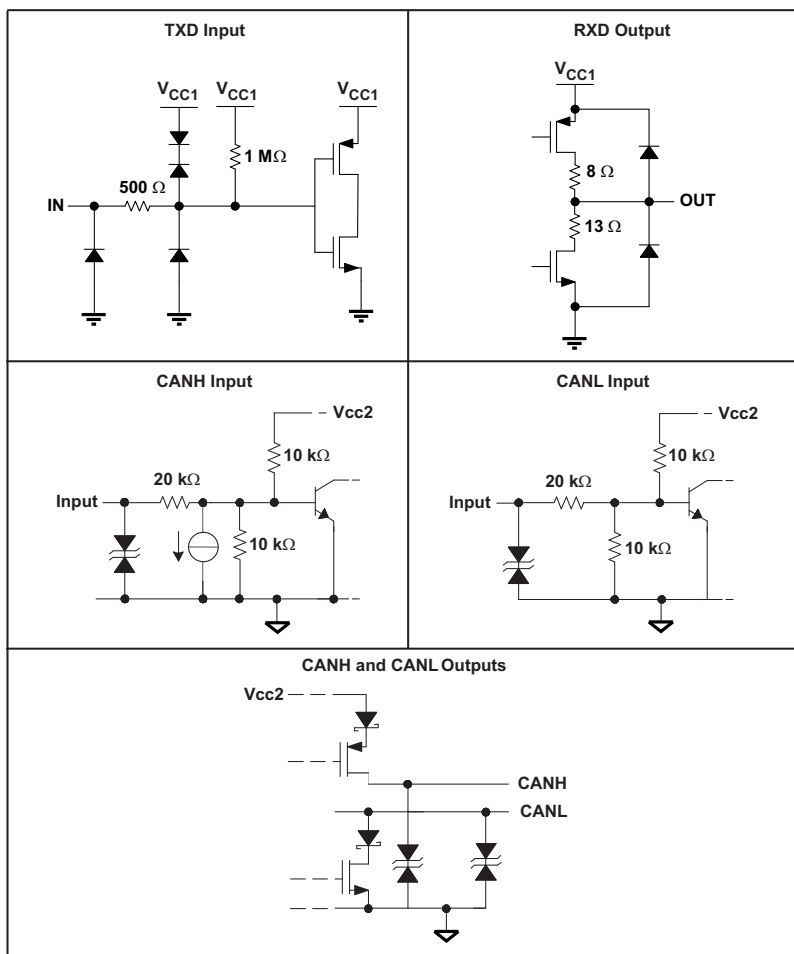
### 9.1 Application Information

ISO1050 can be used with other components from TI such as a microcontroller, a transformer driver, and a linear voltage regulator to form a fully isolated CAN interface.

### 9.2 Typical Application



图 27. Application Circuit

#### 9.2.1 Design Requirements

Unlike optocoupler-based solution, which needs several external components to improve performance, provide bias, or limit current, ISO1050 only needs two external bypass capacitors to operate.

#### 9.2.2 Detailed Design Procedure

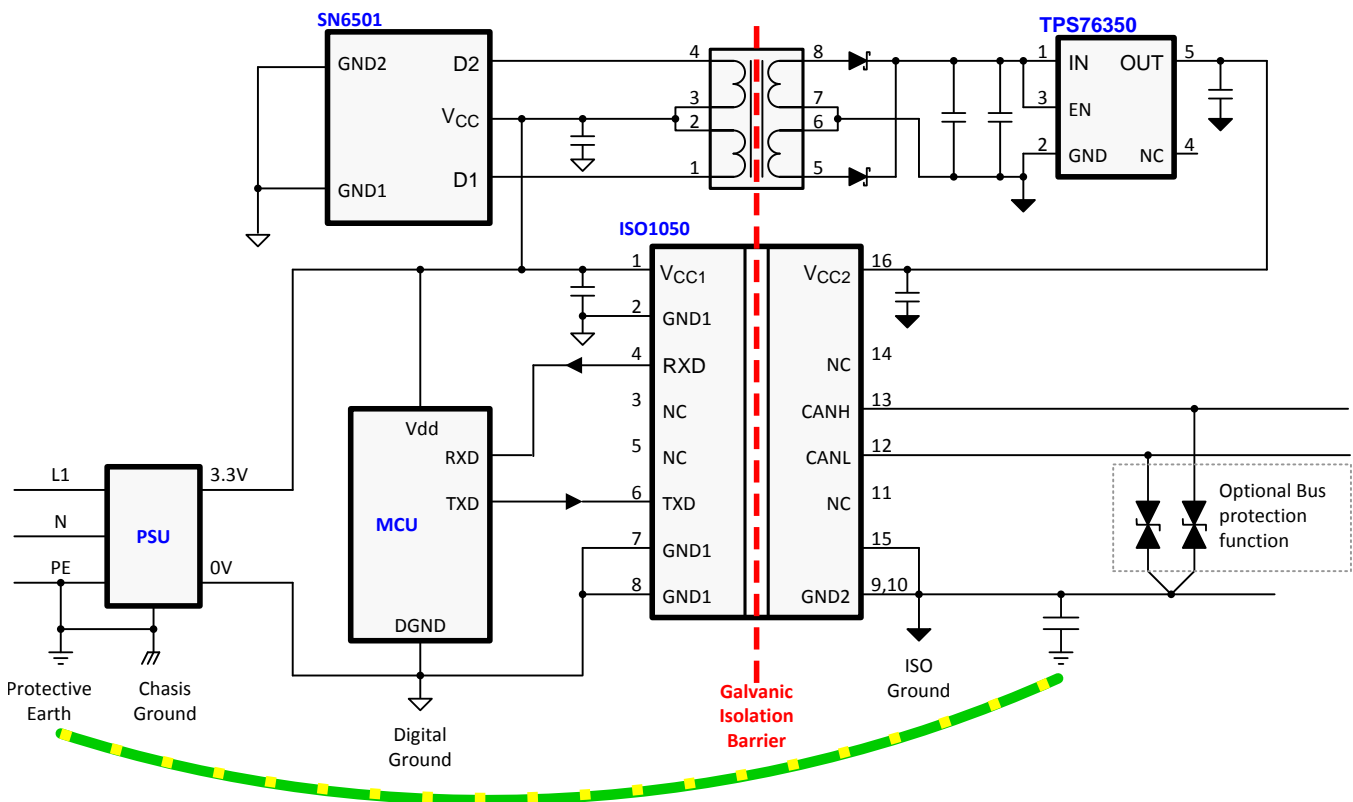
##### 9.2.2.1 Bus Loading, Length and Number of Nodes

The ISO11898 Standard specifies a maximum bus length of 40 m and maximum stub length of 0.3 m with a maximum of 30 nodes. However, with careful design, users can have longer cables, longer stub lengths, and many more nodes to a bus. A high number of nodes requires a transceiver with high input impedance such as the ISO1050.

## Typical Application (接下页)

Many CAN organizations and standards have scaled the use of CAN for applications outside the original ISO11898 standard. They have made system level trade offs for data rate, cable length, and parasitic loading of the bus. Examples of some of these specifications are ARINC825, CANopen, CAN Kingdom, DeviceNet and NMEA200.

A CAN network design is a series of tradeoffs, but these devices operate over wide  $-12\text{-V}$  to  $12\text{-V}$  common-mode range. In ISO11898-2 the driver differential output is specified with a  $60\text{-}\Omega$  load (the two  $120\text{-}\Omega$  termination resistors in parallel) and the differential output must be greater than  $1.5\text{ V}$ . The ISO1050 is specified to meet the  $1.5\text{-V}$  requirement with a  $60\text{-}\Omega$  load, and additionally specified with a differential output of  $1.4\text{ V}$  with a  $45\text{-}\Omega$  load. The differential input resistance of the ISO1050 is a minimum of  $30\text{ k}\Omega$ . If 167 ISO1050 transceivers are in parallel on a bus, this is equivalent to a  $180\text{-}\Omega$  differential load. That transceiver load of  $180\text{ }\Omega$  in parallel with the  $60\text{ }\Omega$  gives a total  $45\text{ }\Omega$ . Therefore, the ISO1050 theoretically supports over 167 transceivers on a single bus segment with margin to the  $1.2\text{-V}$  minimum differential input at each node. However for CAN network design margin must be given for signal loss across the system and cabling, parasitic loadings, network imbalances, ground offsets and signal integrity thus a practical maximum number of nodes is typically much lower. Bus length may also be extended beyond the original ISO11898 standard of  $40\text{ m}$  by careful system design and data rate tradeoffs. For example, CAN open network design guidelines allow the network to be up to  $1\text{ km}$  with changes in the termination resistance, cabling, less than 64 nodes and significantly lowered data rate.

This flexibility in CAN network design is one of the key strengths of the various extensions and additional standards that have been built on the original ISO11898 CAN standard. In using this flexibility comes the responsibility of good network design.

### 9.2.2.2 CAN Termination

The ISO11898 standard specifies the interconnect to be a single twisted pair cable (shielded or unshielded) with  $120\text{-}\Omega$  characteristic impedance ( $Z_0$ ). Resistors equal to the characteristic impedance of the line should be used to terminate both ends of the cable to prevent signal reflections. Unterminated drop-lines (stubs) connecting nodes to the bus should be kept as short as possible to minimize signal reflections. The termination may be in a node, but if nodes may be removed from the bus, the termination must be carefully placed so that it is not removed from the bus.



图 28. Typical CAN Bus

Termination may be a single  $120\text{-}\Omega$  resistor at the end of the bus, either on the cable or in a terminating node. If filtering and stabilization of the common mode voltage of the bus is desired, then split termination may be used. (See 图 29). Split termination improves the electromagnetic emissions behavior of the network by eliminating fluctuations in the bus common-mode voltages at the start and end of message transmissions.

Typical Application (接下页)

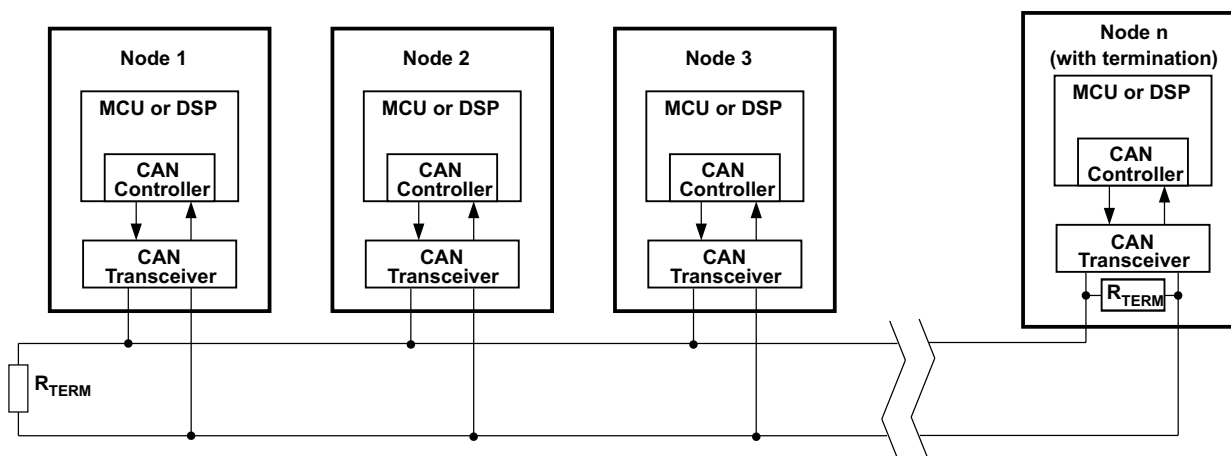

图 29. CAN Bus Termination Concepts

9.2.3 Application Curve

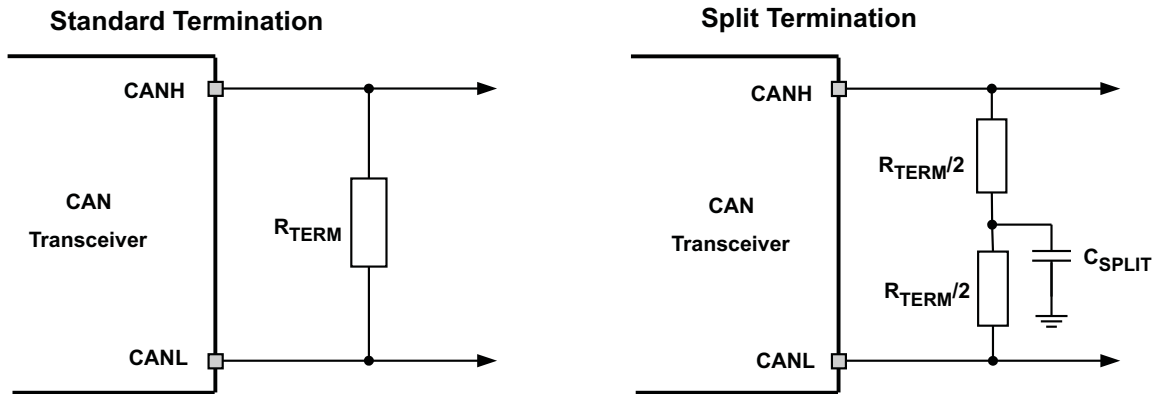
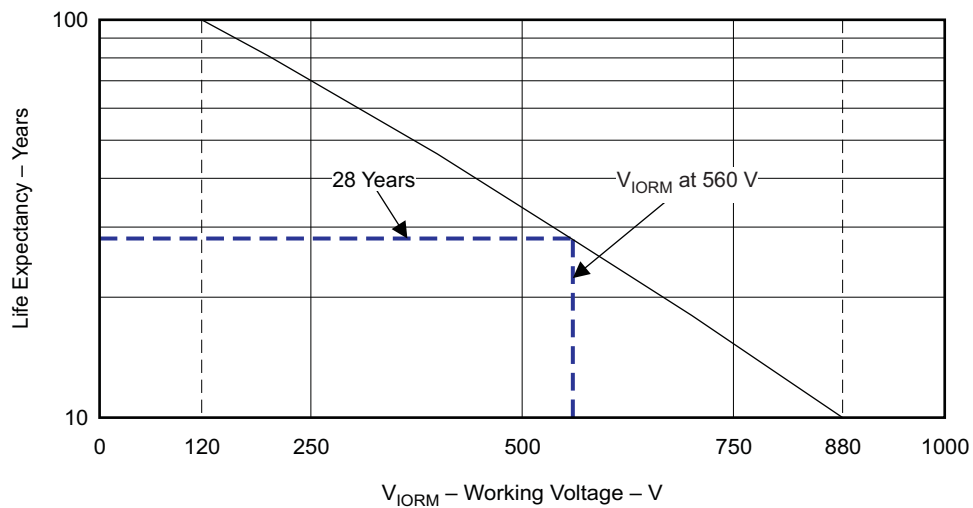

G001

图 30. Life Expectancy vs Working Voltage (ISO1050DUB)

## 10 Power Supply Recommendations

To ensure reliable operation at all data rates and supply voltages, a 0.1- $\mu$ F bypass capacitor is recommended at input and output supply pins ( $V_{CC1}$  and  $V_{CC2}$ ). The capacitors should be placed as close to the supply pins as possible. If only a single primary-side power supply is available in an application, isolated power can be generated for the secondary-side with the help of a transformer driver such as TI's [SN6501](#). For such applications, detailed power supply design and transformer selection recommendations are available in [SN6501](#) data sheet ([SLLSEA0](#)).

## 11 Layout

### 11.1 Layout Guidelines

A minimum of four layers is required to accomplish a low EMI PCB design (see [图 31](#)). Layer stacking should be in the following order (top-to-bottom): high-speed signal layer, ground plane, power plane and low-frequency signal layer.

- Routing the high-speed traces on the top layer avoids the use of vias (and the introduction of their inductances) and allows for clean interconnects between the isolator and the transmitter and receiver circuits of the data link.
- Placing a solid ground plane next to the high-speed signal layer establishes controlled impedance for transmission line interconnects and provides an excellent low-inductance path for the return current flow.
- Placing the power plane next to the ground plane creates additional high-frequency bypass capacitance of approximately 100 pF/in<sup>2</sup>.
- Routing the slower speed control signals on the bottom layer allows for greater flexibility as these signal links usually have margin to tolerate discontinuities such as vias.

If an additional supply voltage plane or signal layer is needed, add a second power / ground plane system to the stack to keep it symmetrical. This makes the stack mechanically stable and prevents it from warping. Also the power and ground plane of each power system can be placed closer together, thus increasing the high-frequency bypass capacitance significantly.

For detailed layout recommendations, see Application Note [SLLA284](#), *Digital Isolator Design Guide*.

#### 11.1.1 PCB Material

For digital circuit boards operating below 150 Mbps, (or rise and fall times higher than 1 ns), and trace lengths of up to 10 inches, use standard FR-4 epoxy-glass as PCB material. FR-4 (Flame Retardant 4) meets the requirements of Underwriters Laboratories UL94-V0, and is preferred over cheaper alternatives due to its lower dielectric losses at high frequencies, less moisture absorption, greater strength and stiffness, and its self-extinguishing flammability-characteristics.

### 11.2 Layout Example

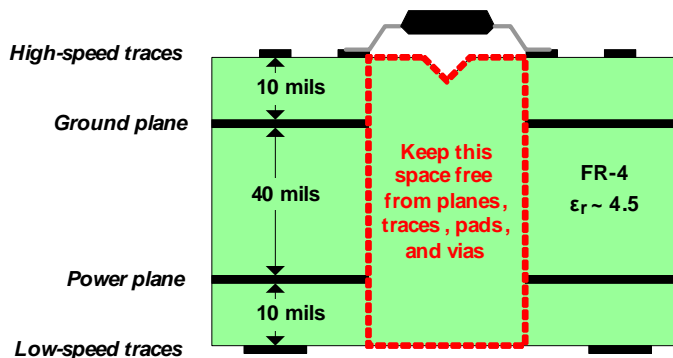

**图 31. Recommended Layer Stack**

## 12 器件和文档支持

### 12.1 文档支持

#### 12.1.1 相关文档

- 《ISO72x 系列数字隔离器高压使用寿命》（文献编号：[SLLA197](#)）
- 《用于隔离电源的变压器驱动器》（文献编号：[SLLSEA0](#)）
- 《数字隔离器设计指南》（文献编号：[SLLA284](#)）

### 12.2 商标

All trademarks are the property of their respective owners.

### 12.3 静电放电警告



这些装置包含有限的内置 ESD 保护。存储或装卸时，应将导线一起截短或将装置放置于导电泡棉中，以防止 MOS 门极遭受静电损伤。

### 12.4 术语表

[SLYZ022](#) — *TI* 术语表。

这份术语表列出并解释术语、首字母缩略词和定义。

[SLLA353](#) -- 《隔离相关术语》。

## 13 机械封装和可订购信息

以下页中包括机械封装和可订购信息。 这些信息是针对指定器件可提供的最新数据。 这些数据会在无通知且不对本文档进行修订的情况下发生改变。 欲获得该数据表的浏览器版本，请查阅左侧的导航栏。

**PACKAGING INFORMATION**

| Orderable Device | Status<br>(1) | Package Type | Package Drawing | Pins | Package Qty | Eco Plan<br>(2) | Lead finish/<br>Ball material<br>(6) | MSL Peak Temp<br>(3) | Op Temp (°C) | Device Marking<br>(4/5) | Samples                 |
|------------------|---------------|--------------|-----------------|------|-------------|-----------------|--------------------------------------|----------------------|--------------|-------------------------|-------------------------|
| ISO1050DUB       | ACTIVE        | SOP          | DUB             | 8    | 50          | RoHS & Green    | NIPDAU                               | Level-4-260C-72 HR   | -55 to 105   | ISO1050                 | <a href="#">Samples</a> |
| ISO1050DUBR      | ACTIVE        | SOP          | DUB             | 8    | 350         | RoHS & Green    | NIPDAU                               | Level-4-260C-72 HR   | -55 to 105   | ISO1050                 | <a href="#">Samples</a> |
| ISO1050DW        | ACTIVE        | SOIC         | DW              | 16   | 40          | RoHS & Green    | NIPDAU                               | Level-2-260C-1 YEAR  | -55 to 105   | ISO1050                 | <a href="#">Samples</a> |
| ISO1050DWR       | ACTIVE        | SOIC         | DW              | 16   | 2000        | RoHS & Green    | NIPDAU                               | Level-2-260C-1 YEAR  | -55 to 105   | ISO1050                 | <a href="#">Samples</a> |

(1) The marketing status values are defined as follows:

**ACTIVE:** Product device recommended for new designs.

**LIFEBUY:** TI has announced that the device will be discontinued, and a lifetime-buy period is in effect.

**NRND:** Not recommended for new designs. Device is in production to support existing customers, but TI does not recommend using this part in a new design.

**PREVIEW:** Device has been announced but is not in production. Samples may or may not be available.

**OBSELETE:** TI has discontinued the production of the device.

(2) **RoHS:** TI defines "RoHS" to mean semiconductor products that are compliant with the current EU RoHS requirements for all 10 RoHS substances, including the requirement that RoHS substance do not exceed 0.1% by weight in homogeneous materials. Where designed to be soldered at high temperatures, "RoHS" products are suitable for use in specified lead-free processes. TI may reference these types of products as "Pb-Free".

**RoHS Exempt:** TI defines "RoHS Exempt" to mean products that contain lead but are compliant with EU RoHS pursuant to a specific EU RoHS exemption.

**Green:** TI defines "Green" to mean the content of Chlorine (Cl) and Bromine (Br) based flame retardants meet JS709B low halogen requirements of <=1000ppm threshold. Antimony trioxide based flame retardants must also meet the <=1000ppm threshold requirement.

(3) MSL, Peak Temp. - The Moisture Sensitivity Level rating according to the JEDEC industry standard classifications, and peak solder temperature.

(4) There may be additional marking, which relates to the logo, the lot trace code information, or the environmental category on the device.

(5) Multiple Device Markings will be inside parentheses. Only one Device Marking contained in parentheses and separated by a "-" will appear on a device. If a line is indented then it is a continuation of the previous line and the two combined represent the entire Device Marking for that device.

(6) Lead finish/Ball material - Orderable Devices may have multiple material finish options. Finish options are separated by a vertical ruled line. Lead finish/Ball material values may wrap to two lines if the finish value exceeds the maximum column width.

**Important Information and Disclaimer:**The information provided on this page represents TI's knowledge and belief as of the date that it is provided. TI bases its knowledge and belief on information provided by third parties, and makes no representation or warranty as to the accuracy of such information. Efforts are underway to better integrate information from third parties. TI has taken and

continues to take reasonable steps to provide representative and accurate information but may not have conducted destructive testing or chemical analysis on incoming materials and chemicals. TI and TI suppliers consider certain information to be proprietary, and thus CAS numbers and other limited information may not be available for release.

In no event shall TI's liability arising out of such information exceed the total purchase price of the TI part(s) at issue in this document sold by TI to Customer on an annual basis.

## TAPE AND REEL INFORMATION

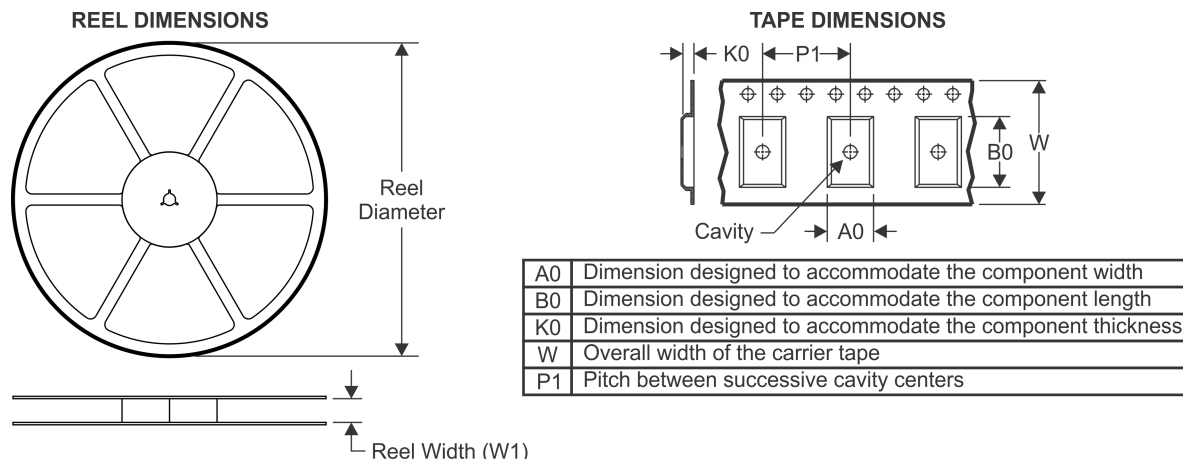

### QUADRANT ASSIGNMENTS FOR PIN 1 ORIENTATION IN TAPE



\*All dimensions are nominal

| Device      | Package Type | Package Drawing | Pins | SPQ  | Reel Diameter (mm) | Reel Width W1 (mm) | A0 (mm) | B0 (mm) | K0 (mm) | P1 (mm) | W (mm) | Pin1 Quadrant |
|-------------|--------------|-----------------|------|------|--------------------|--------------------|---------|---------|---------|---------|--------|---------------|
| ISO1050DUBR | SOP          | DUB             | 8    | 350  | 330.0              | 24.4               | 13.1    | 9.75    | 6.0     | 16.0    | 24.0   | Q1            |
| ISO1050DUBR | SOP          | DUB             | 8    | 350  | 330.0              | 24.4               | 10.9    | 10.01   | 5.85    | 16.0    | 24.0   | Q1            |
| ISO1050DWR  | SOIC         | DW              | 16   | 2000 | 330.0              | 16.4               | 10.75   | 10.7    | 2.7     | 12.0    | 16.0   | Q1            |

**TAPE AND REEL BOX DIMENSIONS**

\*All dimensions are nominal

| Device      | Package Type | Package Drawing | Pins | SPQ  | Length (mm) | Width (mm) | Height (mm) |
|-------------|--------------|-----------------|------|------|-------------|------------|-------------|
| ISO1050DUBR | SOP          | DUB             | 8    | 350  | 367.0       | 367.0      | 45.0        |
| ISO1050DUBR | SOP          | DUB             | 8    | 350  | 346.0       | 346.0      | 41.0        |
| ISO1050DWR  | SOIC         | DW              | 16   | 2000 | 350.0       | 350.0      | 43.0        |

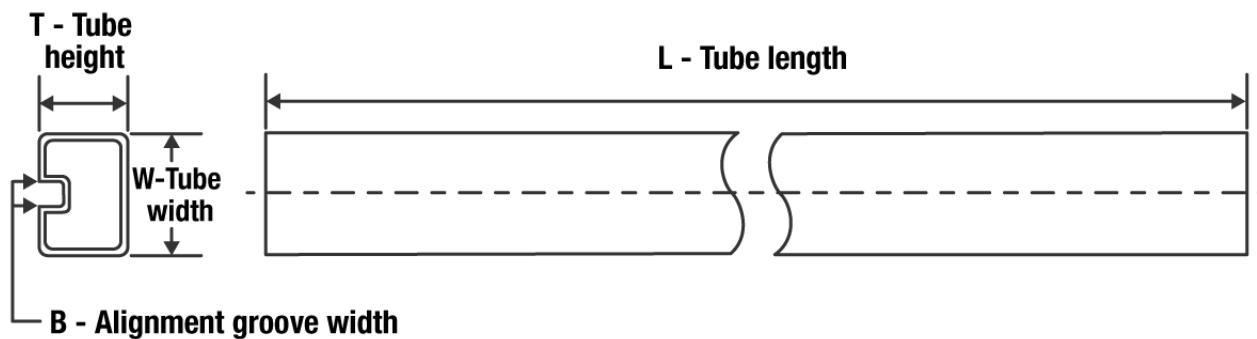
**TUBE**

\*All dimensions are nominal

| Device     | Package Name | Package Type | Pins | SPQ | L (mm) | W (mm) | T (μm) | B (mm) |
|------------|--------------|--------------|------|-----|--------|--------|--------|--------|
| ISO1050DUB | DUB          | SOP          | 8    | 50  | 532.13 | 13     | 7300   | 6.6    |
| ISO1050DUB | DUB          | SOP          | 8    | 50  | 532.13 | 13.51  | 7.36   | 6.91   |
| ISO1050DW  | DW           | SOIC         | 16   | 40  | 506.98 | 12.7   | 4826   | 6.6    |

## GENERIC PACKAGE VIEW

**DUB 8**

**SOP - 4.85 mm max height**

SMALL OUTLINE PACKAGE

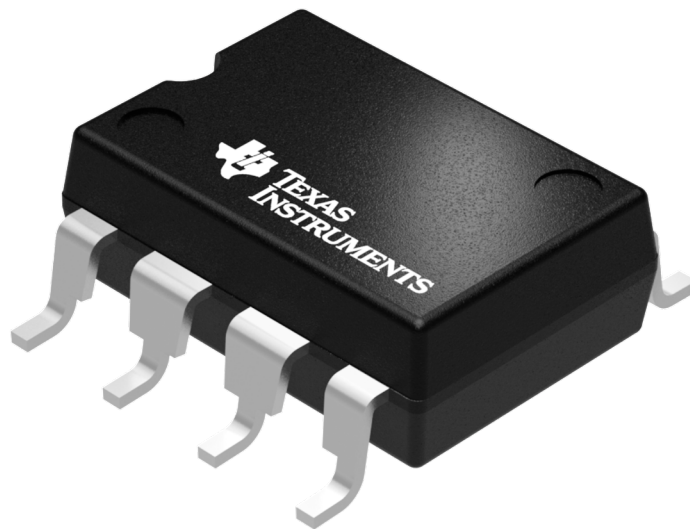

Images above are just a representation of the package family, actual package may vary.  
Refer to the product data sheet for package details.

4207614/E

# DUB0008A



# PACKAGE OUTLINE

SOP - 4.85 mm max height

SMALL OUTLINE PACKAGE

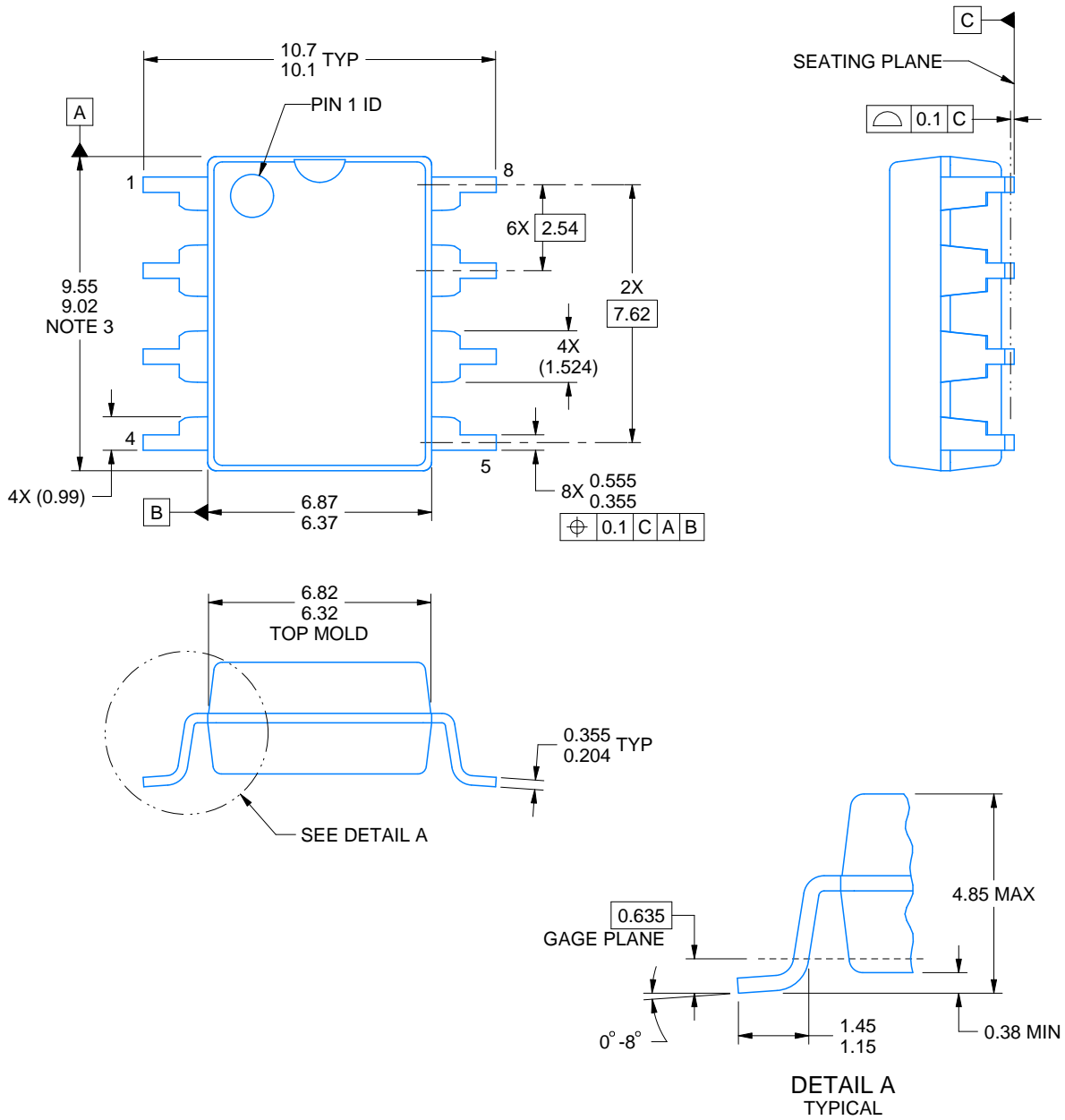

4222355/G 04/2019

**NOTES:**

1. All linear dimensions are in millimeters. Any dimensions in parenthesis are for reference only. Dimensioning and tolerancing per ASME Y14.5M.
2. This drawing is subject to change without notice.
3. This dimension does not include mold flash, protrusions, or gate burrs. Mold flash, protrusions, or gate burrs shall not exceed 0.254 mm per side.

# EXAMPLE BOARD LAYOUT

DUB0008A

SOP - 4.85 mm max height

SMALL OUTLINE PACKAGE

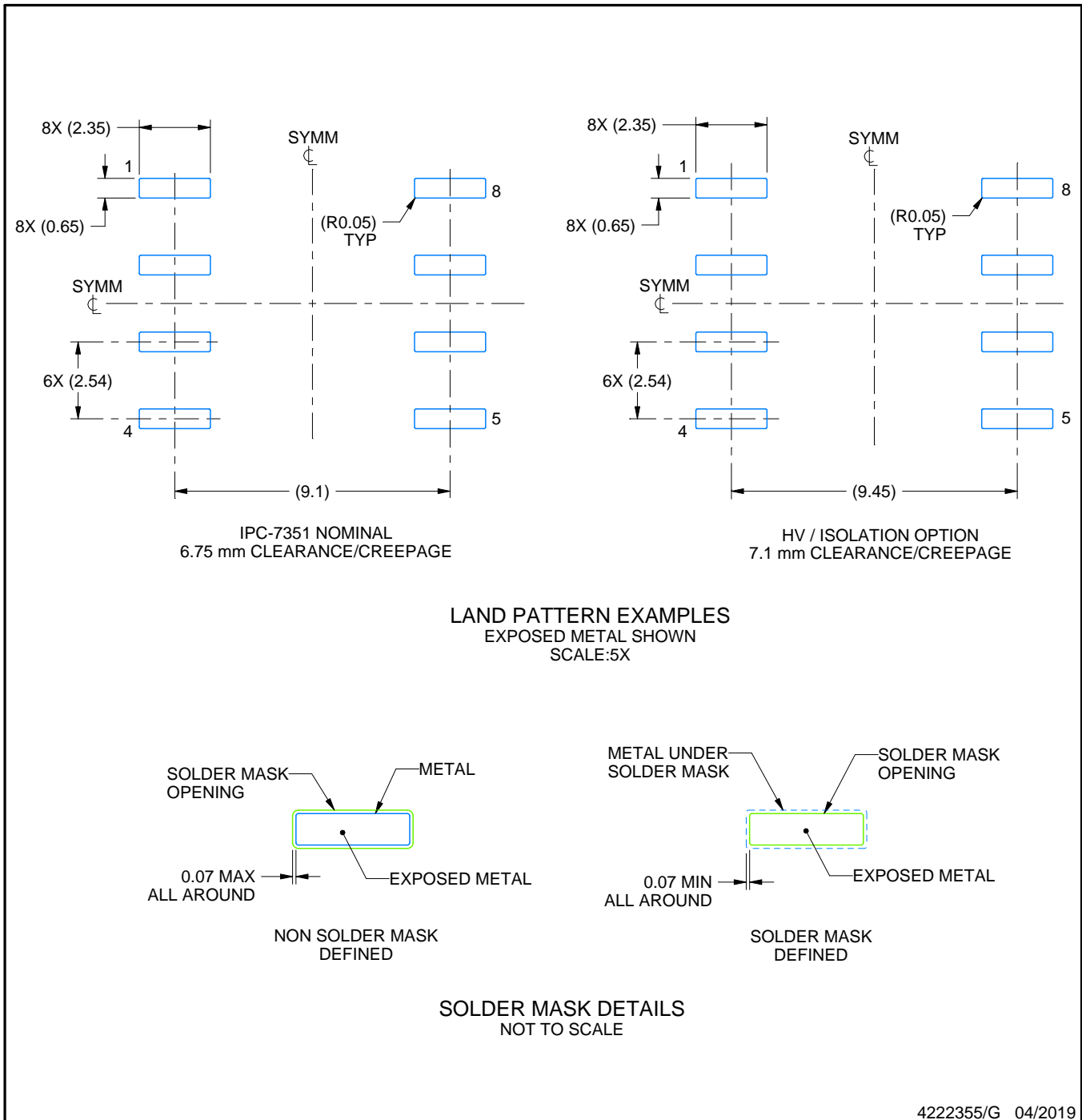

NOTES: (continued)

4. Publication IPC-7351 may have alternate designs.
5. Solder mask tolerances between and around signal pads can vary based on board fabrication site.

# EXAMPLE STENCIL DESIGN

DUB0008A

SOP - 4.85 mm max height

SMALL OUTLINE PACKAGE

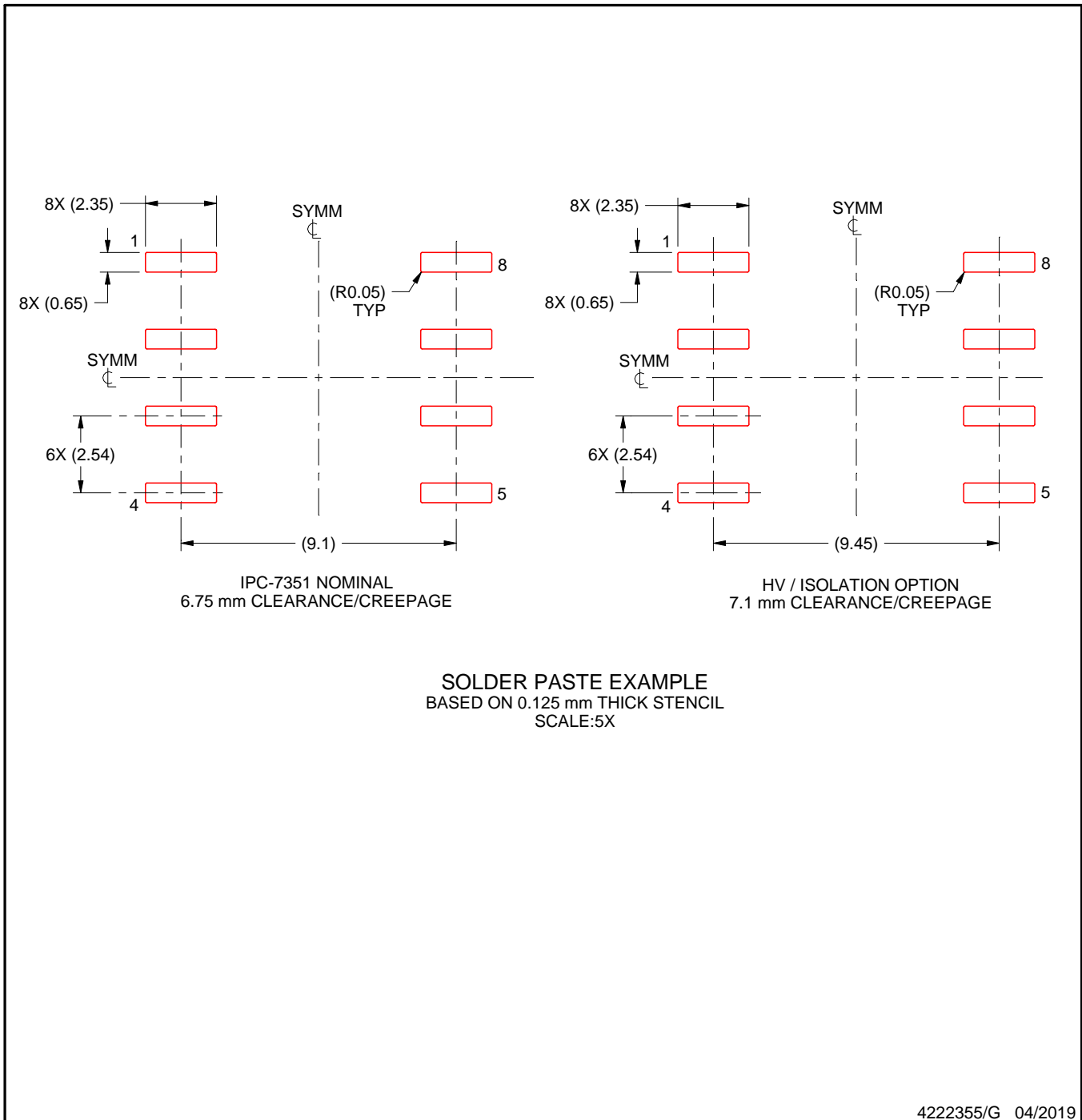

NOTES: (continued)

6. Laser cutting apertures with trapezoidal walls and rounded corners may offer better paste release. IPC-7525 may have alternate design recommendations.
7. Board assembly site may have different recommendations for stencil design.

## 重要声明和免责声明

TI“按原样”提供技术和可靠性数据（包括数据表）、设计资源（包括参考设计）、应用或其他设计建议、网络工具、安全信息和其他资源，不保证没有瑕疵且不做任何明示或暗示的担保，包括但不限于对适销性、某特定用途方面的适用性或不侵犯任何第三方知识产权的暗示担保。

这些资源可供使用 TI 产品进行设计的熟练开发人员使用。您将自行承担以下全部责任：(1) 针对您的应用选择合适的 TI 产品，(2) 设计、验证并测试您的应用，(3) 确保您的应用满足相应标准以及任何其他功能安全、信息安全、监管或其他要求。

这些资源如有变更，恕不另行通知。TI 授权您仅可将这些资源用于研发本资源所述的 TI 产品的应用。严禁对这些资源进行其他复制或展示。您无权使用任何其他 TI 知识产权或任何第三方知识产权。您应全额赔偿因在这些资源的使用中对 TI 及其代表造成的任何索赔、损害、成本、损失和债务，TI 对此概不负责。

TI 提供的产品受 [TI 的销售条款](#) 或 [ti.com](#) 上其他适用条款/TI 产品随附的其他适用条款的约束。TI 提供这些资源并不会扩展或以其他方式更改 TI 针对 TI 产品发布的适用的担保或担保免责声明。

TI 反对并拒绝您可能提出的任何其他或不同的条款。

邮寄地址：Texas Instruments, Post Office Box 655303, Dallas, Texas 75265

Copyright © 2022，德州仪器 (TI) 公司