



16-BIT 40-KSPS LOW POWER SAMPLING ANALOG-TO-DIGITAL CONVERTER WITH INTERNAL REFERENCE AND PARALLEL/SERIAL INTERFACE

FEATURES

- 40-kHz Min Sampling Rate
- 4-V, 5-V, and ± 10 -V Input Ranges
- 89.9-dB SINAD with 10-kHz Input
- ± 1.5 LSB Max INL
- $+1.5/-1$ LSB Max DNL, 16-Bit No Missing Codes
- ± 5 -mV BPZ, ± 0.4 PPM/ $^{\circ}$ C BPZ Drift
- SPI Compatible Serial Output With Daisy-Chain (TAG) Feature
- Single 5-V Analog Supply
- Pin-Compatible With ADS7807 and 12-Bit ADS7806/8506
- Uses Internal or External 2.5-V Reference
- Low Power Dissipation
 - 24 mW Typ, 30 mW Max at 40 KSPS
- 50- μ W Max Power Down Mode
- 28-Pin SO Package
- Full Parallel Interface
- 2's Comp or BTC Output Code

APPLICATIONS

- Industrial Process Control
- Test Equipment
- Medical Equipment
- Data Acquisition Systems
- Digital Signal Processing
- Instrumentation

DESCRIPTION

The ADS8507 is a complete low power, single 5-V supply, 16-bit sampling analog-to-digital (A/D) converter. It contains a complete 16-bit capacitor-based, successive approximation register (SAR) A/D converter with sample and hold, clock, reference, and data interface. The converter can be configured for a variety of input ranges including ± 10 V, 4 V, and 5 V. For most input ranges, the input voltage can swing to 25 V or -25 V without damage to the converter.

A SPI compatible serial interface allows data to be synchronized to an internal or external clock. A full parallel interface with BYTE select is also provided to allow the maximum system design flexibility. The ADS8507 is specified at 40 kHz sampling rate over the industrial -40° C to 85° C temperature range.

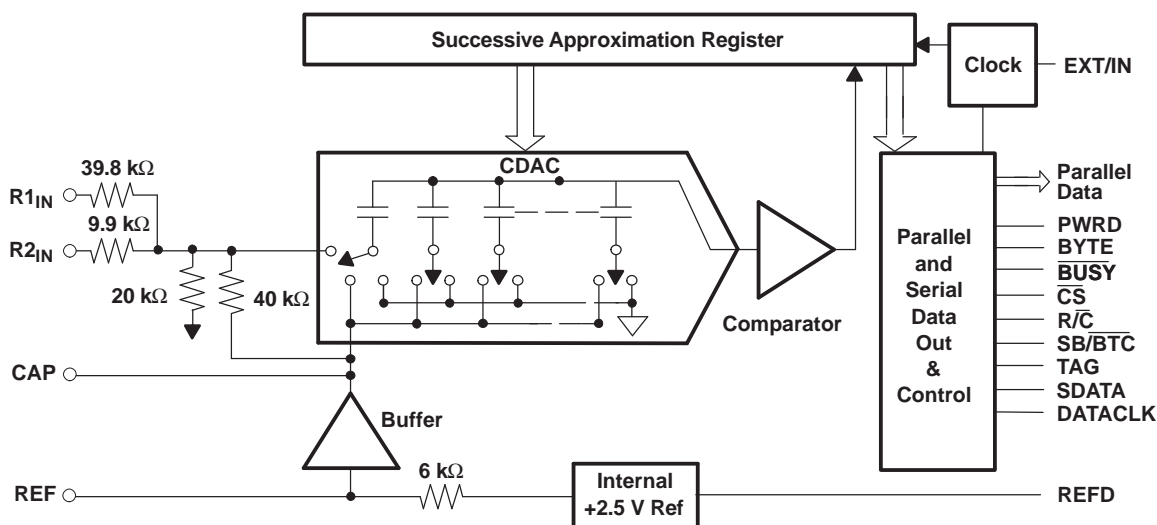

Please be aware that an important notice concerning availability, standard warranty, and use in critical applications of Texas Instruments semiconductor products and disclaimers thereto appears at the end of this data sheet.

QSPI, SPI are trademarks of Motorola.



These devices have limited built-in ESD protection. The leads should be shorted together or the device placed in conductive foam during storage or handling to prevent electrostatic damage to the MOS gates.

PACKAGE/ORDERING INFORMATION⁽¹⁾

PRODUCT	MINIMUM RELATIVE ACCURACY (LSB)	NO MISSING CODE	MINIMUM SINAD (dB)	SPECIFICATION TEMPERATURE RANGE	PACKAGE LEAD	PACKAGE DESIGNATOR	ORDERING NUMBER	TRANSPORT MEDIA, QTY
ADS8507IB	±1.5	16	87	-40°C to 85°C	SO-28	DW	ADS8507IBDW	Tube, 20
							ADS8507IBDWR	Tape and Reel, 1000
ADS8507I	±3	15	83	-40°C to 85°C	SO-28	DW	ADS8507IDW	Tube, 20
							ADS8507IDWR	Tape and Reel, 1000

(1) For the most current package and ordering information, see the Package Option Addendum at the end of this document, or see the TI website at www.ti.com.

ABSOLUTE MAXIMUM RATINGS

over operating free-air temperature range (unless otherwise noted)⁽¹⁾

		UNIT
Analog inputs	R1 _{IN}	±25 V
	R2 _{IN}	±25 V
	REF	+V _{ANA} + 0.3 V to AGND2 - 0.3 V
Ground voltage differences	DGND, AGND2	±0.3 V
	V _{ANA}	6 V
	V _{DIG} to V _{ANA}	0.3 V
	V _{DIG}	6 V
Digital inputs		-0.3 V to +V _{DIG} + 0.3 V
Maximum junction temperature		165°C
Storage temperature range		-65°C to 150°C
Internal power dissipation		700 mW
Lead temperature (soldering, 1.6 mm from case 10 seconds)		260°C

(1) All voltage values are with respect to network ground terminal.

ELECTRICAL CHARACTERISTICS

At T_A = -40°C to 85°C, f_S = 40 kHz, V_{DIG} = V_{ANA} = 5 V, and using internal reference and fixed resistors, (see [Figure 43](#)) unless otherwise specified.

PARAMETER	TEST CONDITIONS	ADS8507I			ADS8507IB			UNIT
		MIN	TYP	MAX	MIN	TYP	MAX	
Resolution				16			16	Bits
ANALOG INPUT								
Voltage ranges	See Table 1	-10		10	-10		10	V
		0		5	0		5	
		0		4	0		4	
Impedance								
Capacitance			45		45			pF
THROUGHPUT SPEED								
Conversion time	Acquire and convert			20			20	µs
Complete cycle				25			25	
Throughput rate		40			40			kHz
DC ACCURACY								
INL	Integral linearity error	-3		3	-1.5		1.5	LSB ⁽¹⁾

(1) LSB means Least Significant Bit. One LSB for the ±10 V input range is 305 µV.

ELECTRICAL CHARACTERISTICS (continued)

At $T_A = -40^\circ\text{C}$ to 85°C , $f_S = 40\text{ kHz}$, $V_{\text{DIG}} = V_{\text{ANA}} = 5\text{ V}$, and using internal reference and fixed resistors, (see [Figure 43](#)) unless otherwise specified.

PARAMETER	TEST CONDITIONS	ADS8507I			ADS8507IB			UNIT	
		MIN	TYP	MAX	MIN	TYP	MAX		
DNL	Differential linearity error	-2		3	-1		1.5	LSB	
	No missing codes	15			16			Bits	
	Transition noise ⁽²⁾		0.8			0.8		LSB	
	Gain Error		± 0.2			± 0.1		%	
	Full scale error ⁽³⁾⁽⁴⁾	-0.5		0.5	-0.25		0.25	%	
	Full scale error drift		± 7			± 5		ppm/ $^\circ\text{C}$	
	Full scale error ⁽³⁾⁽⁴⁾	Ext. 2.5-V Ref		0.5	-0.25		0.25	%	
	Full scale error drift	Ext. 2.5-V Ref		± 0.5		± 0.5		ppm/ $^\circ\text{C}$	
	Bipolar zero error ⁽³⁾	$\pm 10\text{ V}$ Range	-10		10	-5		5 mV	
	Bipolar zero error drift	$\pm 10\text{ V}$ Range		± 0.5		± 0.5		ppm/ $^\circ\text{C}$	
	Unipolar zero error ⁽⁵⁾	0 V to 5 V, 0 V to 4 V Ranges	-3		3	-3		3 mV	
	Unipolar zero error drift	0 V to 5 V, 0 V to 4 V Ranges		± 0.5		± 0.5		ppm/ $^\circ\text{C}$	
	Recovery time to rated accuracy from power down ⁽⁶⁾	2.2- μF Capacitor to CAP		1		1		ms	
	Power supply sensitivity ($V_{\text{DIG}} = V_{\text{ANA}} = V_S$)	+4.75 V < V_S < +5.25 V			± 8		± 8	LSB	
AC ACCURACY									
SFDR	Spurious-free dynamic range	$f_{\text{IN}} = 1\text{ kHz}, \pm 10\text{ V}$	90	100		96	102	dB ⁽⁷⁾	
THD	Total harmonic distortion	$f_{\text{IN}} = 1\text{ kHz}, \pm 10\text{ V}$		-100	-90		-100	-96	dB
SINAD	Signal-to-(noise+distortion)	$f_{\text{IN}} = 1\text{ kHz}, \pm 10\text{ V}$ -60 dB Input	83	88		87	89.9	dB	
SNR	Signal-to-noise		83	88		87	89.9	dB	
	Usable bandwidth ⁽⁸⁾	$f_{\text{IN}} = 1\text{ kHz}, \pm 10\text{ V}$		130			130	kHz	
	Full-power bandwidth (-3 dB)			600			600	kHz	
SAMPLING DYNAMICS									
	Aperture delay			40		40		ns	
	Aperture jitter			20		20		ps	
	Transient response	FS Step			5		5	μs	
	Overvoltage recovery ⁽⁹⁾			750		750		ns	
REFERENCE									
	Internal reference voltage	No load	2.48	2.5	2.52	2.48	2.5	2.52	V
	Internal reference source current (must use external buffer)			1			1		μA
	Internal reference drift			8			8		ppm/ $^\circ\text{C}$
	External reference voltage range for specified linearity		2.3	2.5	2.7	2.3	2.5	2.7	V
	External reference current drain	Ext. 2.5-V Ref			100			100	μA
DIGITAL INPUTS									
V_{IL}	Low-level input voltage		-0.3		+0.8	-0.3		+0.8	V
V_{IH}	High-level input voltage		2.0		$V_D + 0.3\text{ V}$	2.0		$V_D + 0.3\text{ V}$	V
I_{IL}	Low-level input current	$V_{\text{IL}} = 0\text{ V}$			± 10			± 10	μA

(2) Typical rms noise at worst case transitions.

(3) As measured with fixed resistors, see [Figure 43](#). Adjustable to zero with external potentiometer.

(4) Full scale error is the worst case of -Full Scale or +Full Scale untrimmed deviation from ideal first and last code transitions, divided by the transition voltage (not divided by the full-scale range) and includes the effect of offset error.

(5) As measured with fixed resistors, see [Figure 43](#). Adjustable to zero with external potentiometer.

(6) This is the time delay after the ADS8507 is brought out of Power-Down mode until all internal settling occurs and the analog input is acquired to rated accuracy. A Convert command after this delay will yield accurate results.

(7) All specifications in dB are referred to a full-scale input.

(8) Usable bandwidth defined as full-scale input frequency at which Signal-to-(Noise + Distortion) degrades to 60 dB.

(9) Recovers to specified performance after $2 \times \text{FS}$ input overvoltage.

ELECTRICAL CHARACTERISTICS (continued)

At $T_A = -40^{\circ}\text{C}$ to 85°C , $f_S = 40\text{ kHz}$, $V_{\text{DIG}} = V_{\text{ANA}} = 5\text{ V}$, and using internal reference and fixed resistors, (see Figure 43) unless otherwise specified.

PARAMETER	TEST CONDITIONS	ADS8507I			ADS8507IB			UNIT
		MIN	TYP	MAX	MIN	TYP	MAX	
I_{IH} High-level input current	$V_{\text{IH}} = 5\text{ V}$			± 10			± 10	μA
DIGITAL OUTPUTS								
Data format - Parallel 16-bits in 2-bytes								
Data coding - Serial binary 2s complement or straight binary								
V_{OL} Low-level output voltage	$I_{\text{SINK}} = 1.6\text{ mA}$			0.4			0.4	V
V_{OH} High-level output voltage	$I_{\text{SOURCE}} = 500\ \mu\text{A}$	4			4			V
Leakage Current	High-Z state, $V_{\text{OUT}} = 0\text{ V}$ to V_{DIG}			± 5			± 5	μA
Output capacitance	High-Z state			15			15	pF
DIGITAL TIMING								
Bus access time	$R_L = 3.3\text{ k}\Omega$, $C_L = 50\text{ pF}$			83			83	ns
Bus relinquish time	$R_L = 3.3\text{ k}\Omega$, $C_L = 10\text{ pF}$			83			83	ns
POWER SUPPLIES								
V_{DIG} Digital voltage	Must be $\leq V_{\text{ANA}}$	4.75	5	5.25	4.75	5	5.25	V
V_{ANA} Analog voltage		4.75	5	5.25	4.75	5	5.25	V
I_{DIG} Digital current			0.6			0.6		mA
I_{ANA} Analog current			4.2			4.2		mA
Power dissipation	$V_{\text{ANA}} = V_{\text{DIG}} = 5\text{ V}$, $f_S = 40\text{ kHz}$		24	30		24	30	mW
	REFD High		20			20		mW
	PWRD and REFD High		50			50		μW
TEMPERATURE RANGE								
Specified performance		-40		85	-40		85	$^{\circ}\text{C}$
Derated performance		-55		125	-55		125	$^{\circ}\text{C}$
Storage temperature		-65		150	-65		150	$^{\circ}\text{C}$
SO	Thermal resistance (θ_{JA})		46			46		$^{\circ}\text{C}/\text{W}$

DEVICE INFORMATION

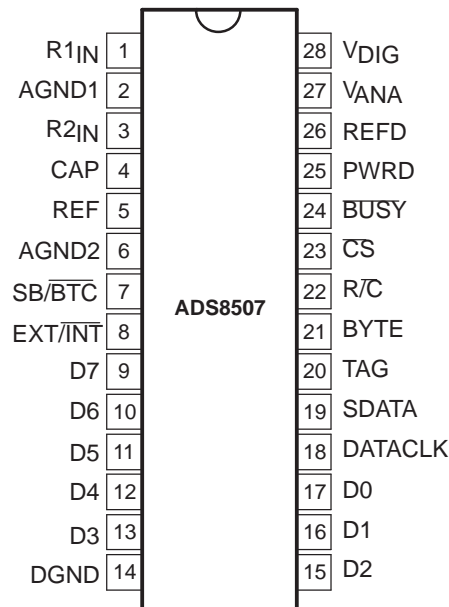

DEVICE INFORMATION (continued)

Terminal Functions

TERMINAL		DIGITAL I/O	DESCRIPTION
NO.	NAME		
1	R1 _{IN}		Analog Input.
2	AGND1		Analog sense ground. Used internally as ground reference point. Minimal current flow
3	R2 _{IN}		Analog Input.
4	CAP		Reference buffer output. 2.2- μ F Tantalum capacitor to ground.
5	REF		Reference input/output. Outputs internal 2.5-V reference. Can also be driven by external system reference. In both cases, bypass to ground with a 2.2- μ F tantalum capacitor.
6	AGND2		Analog ground
7	SB/BTC	I	Selects straight binary or binary 2s complement for output data format. If high, data is output in a straight binary format. If low, data is output in a binary 2's complement format.
8	EXT/ $\overline{\text{INT}}$	I	Selects external/Internal data clock for transmitting data. If high, data is output synchronized to the clock input on DATACLK. If low, a convert command initiates the transmission of the data from the previous conversion, along with 16-clock pulses output on DATACLK.
9	D7	O	Data bit 7 if BYTE is high. Data bit 15 (MSB) if BYTE is low. Hi-Z when CS is high and/or R/C is low. Leave unconnected when using serial output.
10	D6	O	Data bit 6 if BYTE is high. Data bit 14 if BYTE is low. Hi-Z when $\overline{\text{CS}}$ is high and/or R/C is low.
11	D5	O	Data bit 5 if BYTE is high. Data bit 13 if BYTE is low. Hi-Z when $\overline{\text{CS}}$ is high and/or R/C is low.
12	D4	O	Data bit 4 if BYTE is high. Data bit 12 if BYTE is low. Hi-Z when $\overline{\text{CS}}$ is high and/or R/C is low.
13	D3	O	Data bit 3 if BYTE is high. Data bit 11 if BYTE is low. Hi-Z when $\overline{\text{CS}}$ is high and/or R/C is low.
14	DGND		Digital ground
15	D2	O	Data bit 2 if BYTE is high. Data bit 10 if BYTE is low. Hi-Z when $\overline{\text{CS}}$ is high and/or R/C is low.
16	D1	O	Data bit 1 if BYTE is high. Data bit 9 if BYTE is low. Hi-Z when $\overline{\text{CS}}$ is high and/or R/C is low.
17	D0	O	Data bit 0 (LSB) if BYTE is high. Data bit 8 if BYTE is low. Hi-Z when $\overline{\text{CS}}$ is high and/or R/C is low.
18	DATACLK	I/O	Either an input or an output depending on the EXT/ $\overline{\text{INT}}$ level. Output data is synchronized to this clock. If EXT/ $\overline{\text{INT}}$ is low, DATACLK transmits 16 pulses after each conversion, and then remains low between conversions.
19	SDATA	O	Serial data output. Data is synchronized to DATACLK, with the format determined by the level of SB/BTC. In the external clock mode, after 16 bits of data, the ADC outputs the level input on TAG as long as $\overline{\text{CS}}$ is low and R/C is high. If EXT/ $\overline{\text{INT}}$ is low, data is valid on both the rising and falling edges of DATACLK, and between conversions SDATA stays at the level of the TAG input when the conversion was started.
20	TAG	I	Tag input for use in the external clock mode. If EXT is high, digital data input from TAG is output on DATA with a delay that is dependent on the external clock mode.
21	BYTE	I	Selects 8 most significant bits (low) or 8 least significant bits (high) on parallel output pins.
22	R/C	I	Read/convert input. With $\overline{\text{CS}}$ low, a falling edge on R/C puts the internal sample-and-hold into the hold state and starts a conversion. When EXT/ $\overline{\text{INT}}$ is low, this also initiates the transmission of the data results from the previous conversion.
23	$\overline{\text{CS}}$	I	Internally ORed with R/C. If R/C is low, a falling edge on $\overline{\text{CS}}$ initiates a new conversion. If EXT/ $\overline{\text{INT}}$ is low, this same falling edge will start the transmission of serial data results from the previous conversion.
24	$\overline{\text{BUSY}}$	O	At the start of a conversion, $\overline{\text{BUSY}}$ goes low and stays low until the conversion is completed and the digital outputs have been updated.
25	PWRD	I	Power down input. If high, conversions are inhibited and power consumption is significantly reduced. Results from the previous conversion are maintained in the output shift register.
26	REFD	I	REFD High shuts down the internal reference. External reference will be required for conversions.
27	V _{ANA}		Analog Supply. Nominally +5 V. Decouple with 0.1- μ F ceramic and 10- μ F tantalum capacitors.
28	V _{DIG}		Digital Supply. Nominally +5 V. Connect directly to pin 27. Must be \leq V _{ANA} .

Table 1. Input Range Connections (see Figure 42 and Figure 43)

ANALOG INPUT RANGE	CONNECT R1 _{IN} VIA 200 Ω TO	CONNECT R2 _{IN} VIA 100 Ω TO	IMPEDANCE
±10 V	V _{IN}	CAP	45.7 kΩ
0 V to 5 V	AGND	V _{IN}	20.0 kΩ
0 V to 4 V	V _{IN}	V _{IN}	21.4 kΩ

TYPICAL CHARACTERISTICS

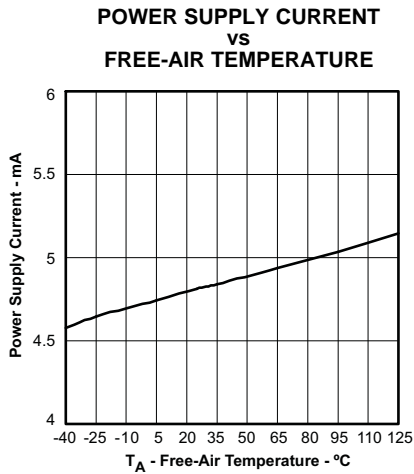

Figure 1.

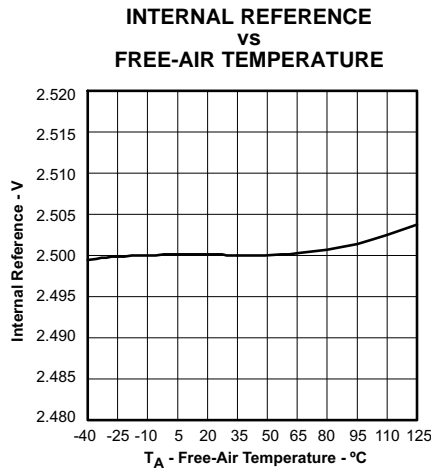

Figure 2.

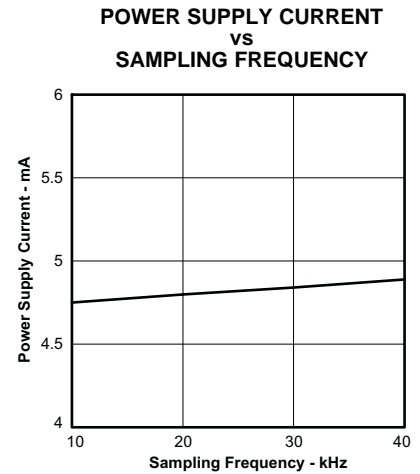

Figure 3.

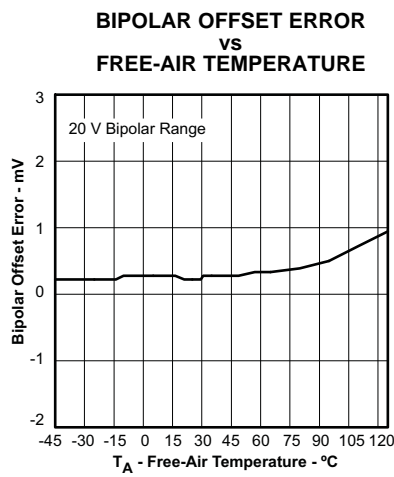

Figure 4.

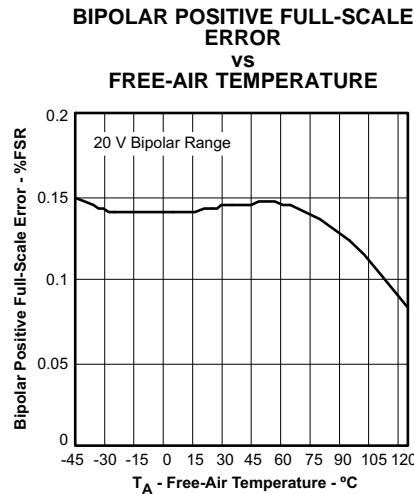

Figure 5.

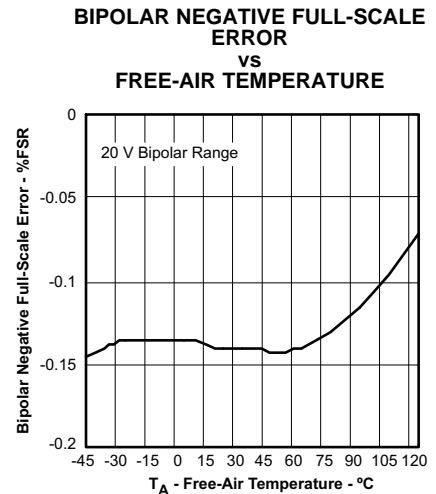

Figure 6.

TYPICAL CHARACTERISTICS (continued)

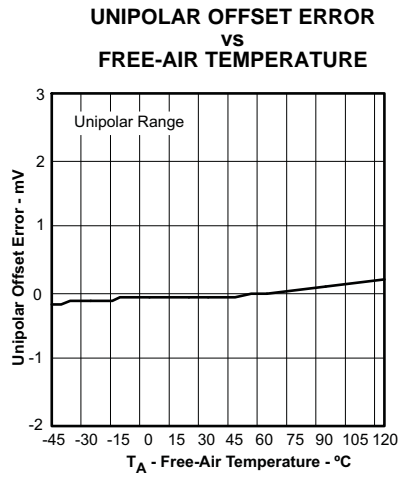

Figure 7.

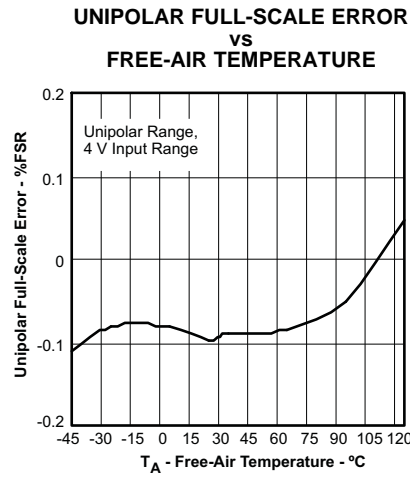

Figure 8.

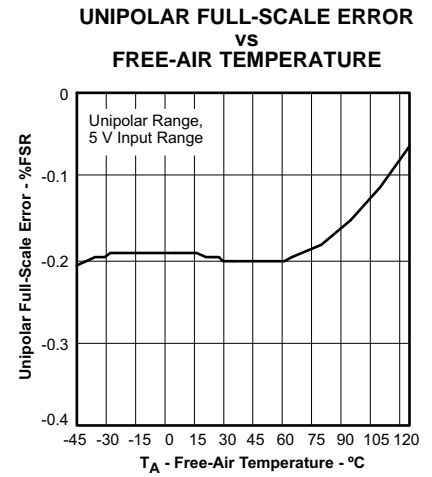

Figure 9.

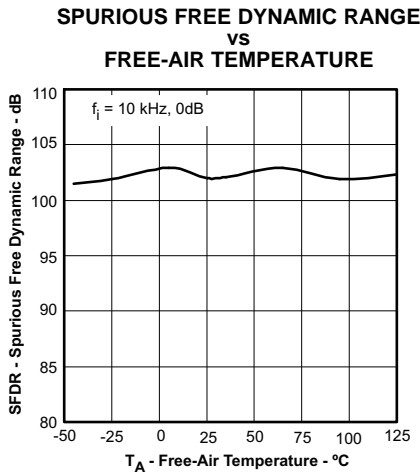

Figure 10.

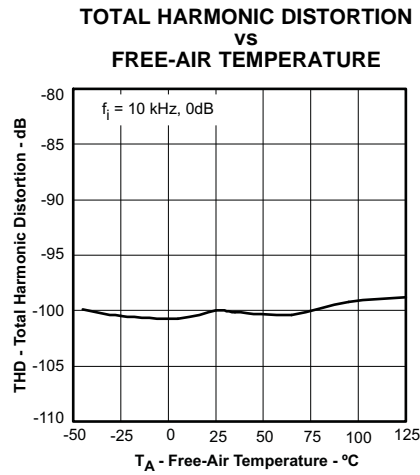

Figure 11.

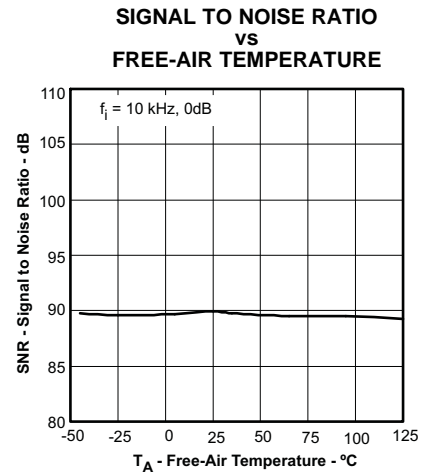

Figure 12.

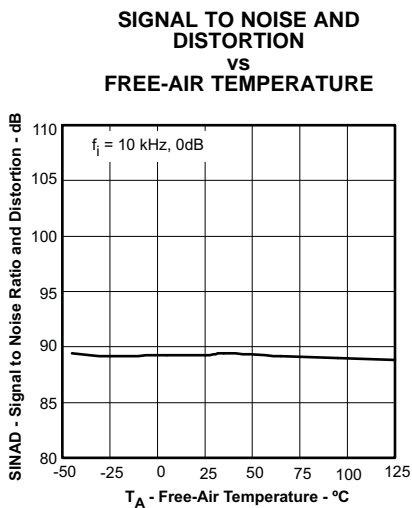

Figure 13.

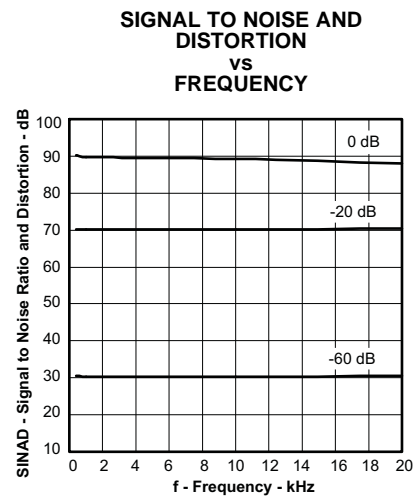

Figure 14.

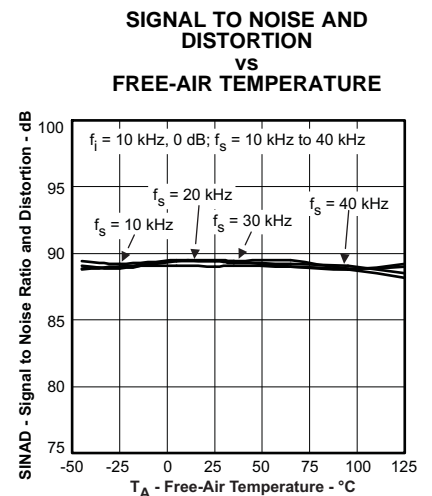

Figure 15.

TYPICAL CHARACTERISTICS (continued)

**SIGNAL-TO-NOISE RATIO
vs
FREQUENCY**

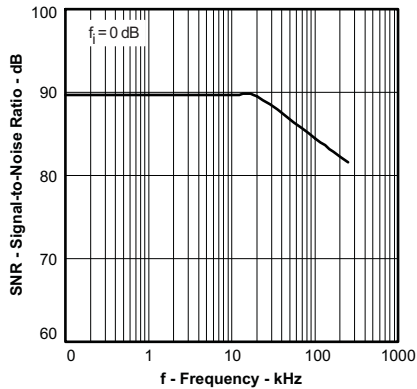

Figure 16.

**SIGNAL-TO-NOISE AND
DISTORTION
vs
FREQUENCY**

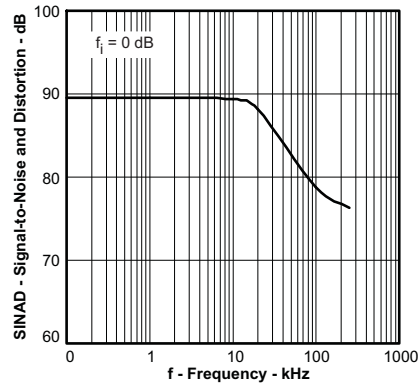

Figure 17.

**SPURIOUS FREE DYNAMIC RANGE
vs
FREQUENCY**

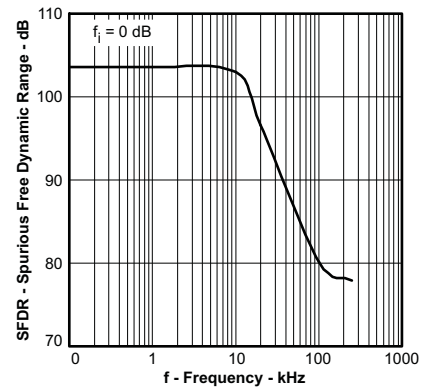

Figure 18.

**TOTAL HARMONIC DISTORTION
vs
FREQUENCY**

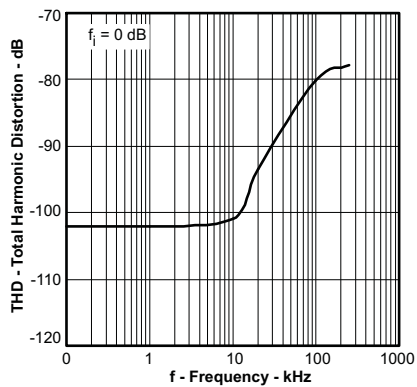

Figure 19.

**SPURIOUS FREE DYNAMIC RANGE
vs
EQUIVALENT SERIES RESISTOR**

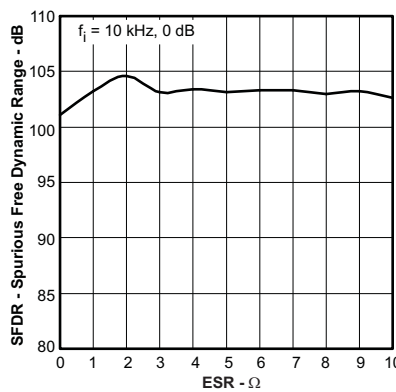

Figure 20.

**TOTAL HARMONIC DISTORTION
vs
EQUIVALENT SERIES RESISTOR**

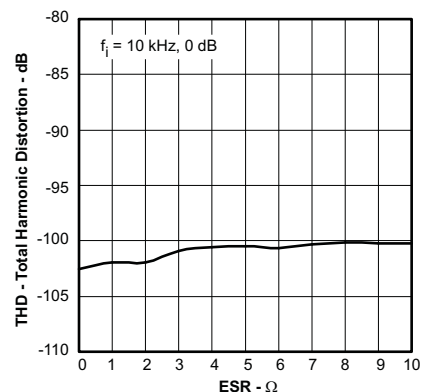

Figure 21.

**SIGNAL TO NOISE RATIO
vs
EQUIVALENT SERIES RESISTOR**

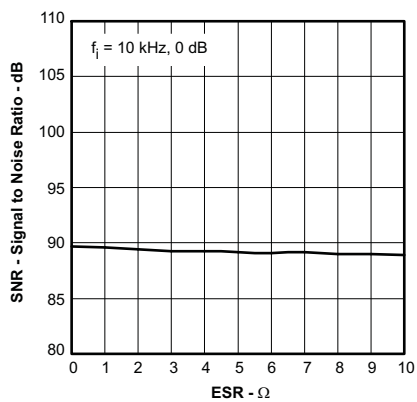

Figure 22.

**SIGNAL TO NOISE RATIO AND
DISTORTION
vs
EQUIVALENT SERIES RESISTOR**

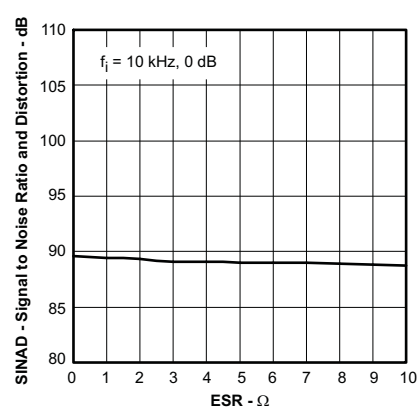

Figure 23.

**OUTPUT REJECTION
vs
POWER-SUPPLY RIPPLE
FREQUENCY**

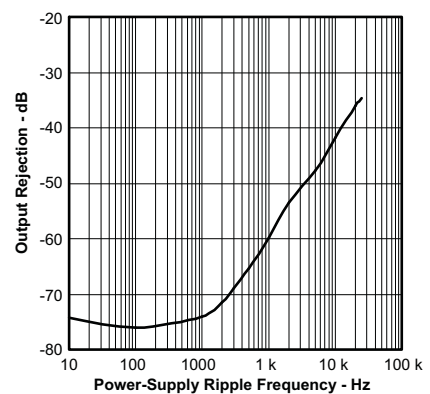

Figure 24.

TYPICAL CHARACTERISTICS (continued)

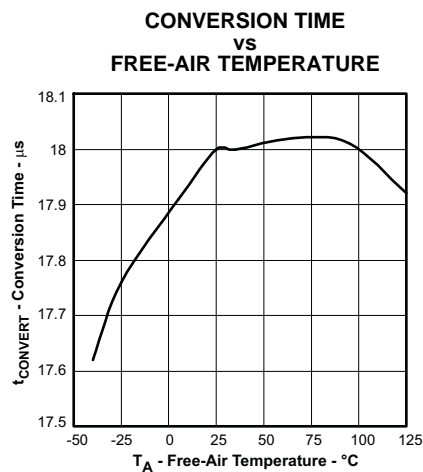

Figure 25.

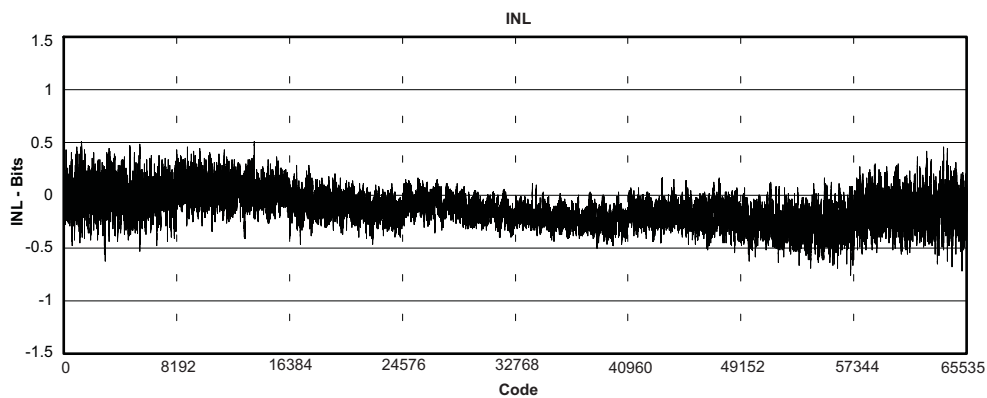

Figure 26.

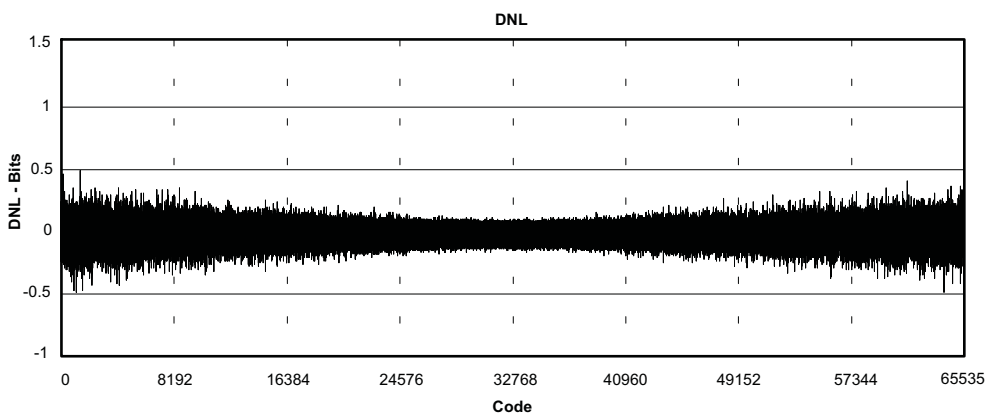

Figure 27.

TYPICAL CHARACTERISTICS (continued)

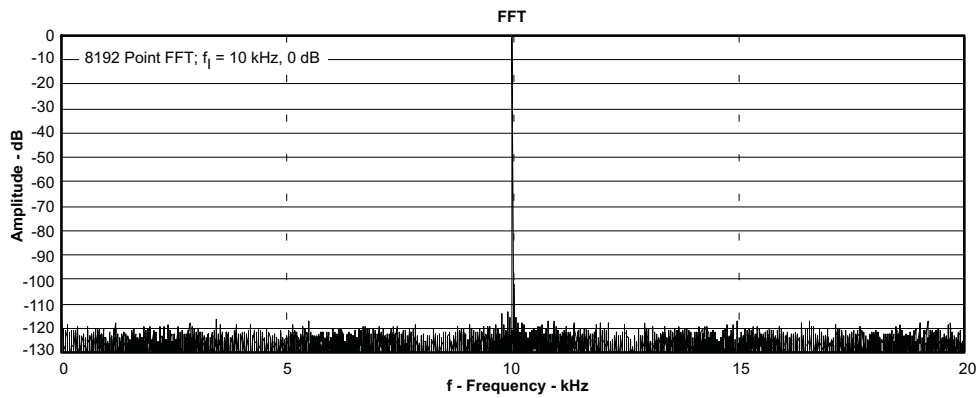

Figure 28.

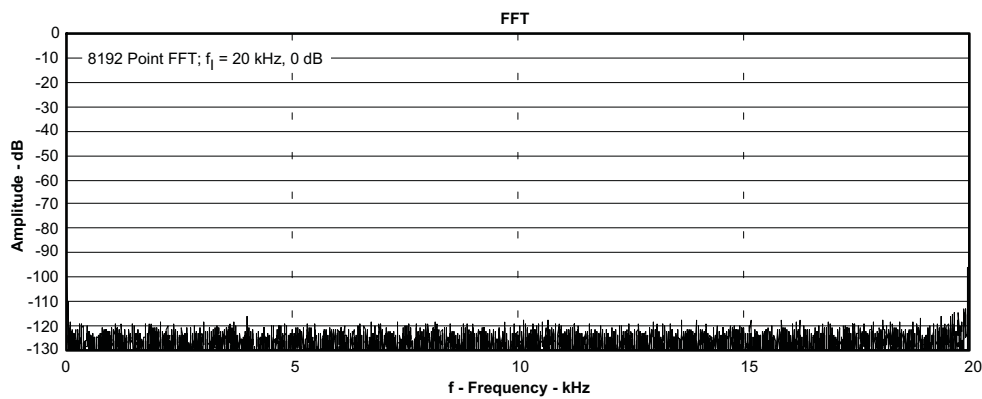

Figure 29.

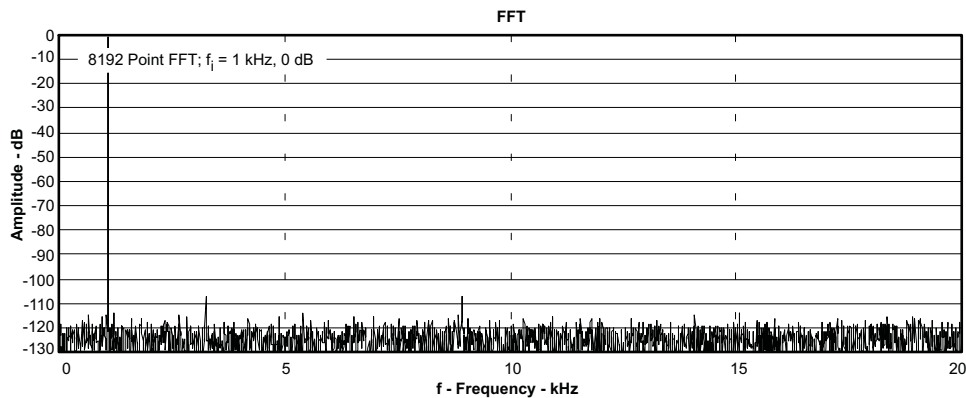

Figure 30.

BASIC OPERATION

PARALLEL OUTPUT

Figure 31 shows a basic circuit to operate the ADS8507 with a ± 10 V input range and parallel output. Taking R/C (pin 22) LOW for a minimum of 40 ns (12 μ s max) will initiate a conversion. BUSY (pin 24) will go LOW and

BASIC OPERATION (continued)

stay LOW until the conversion is completed and the output register is updated. If BYTE (pin 21) is LOW, the eight most significant bits (MSBs) will be valid when $\overline{\text{BUSY}}$ rises; if BYTE is HIGH, the eight least significant bits (LSBs) will be valid when $\overline{\text{BUSY}}$ rises. Data will be output in binary 2's complement (BTC) format. $\overline{\text{BUSY}}$ going HIGH can be used to latch the data. After the first byte has been read, BYTE can be toggled allowing the remaining byte to be read. All convert commands will be ignored while $\overline{\text{BUSY}}$ is LOW.

The ADS8507 begins tracking the input signal at the end of the conversion. Allowing 25 μs between convert commands assures accurate acquisition of a new signal.

The offset and gain are adjusted internally to allow external trimming with a single supply. The external resistors compensate for this adjustment and can be left out if the offset and gain will be corrected in software (refer to the Calibration section).

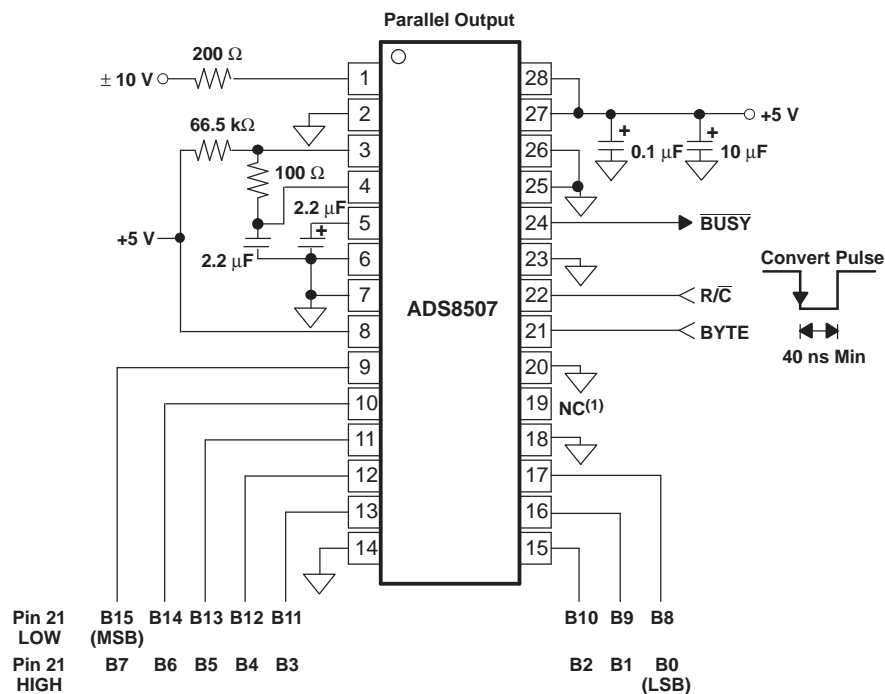

Figure 31. Basic $\pm 10\text{-V}$ Operation, Both Parallel and Serial Output

SERIAL OUTPUT

Figure 32 shows a basic circuit to operate the ADS8507 with a $\pm 10\text{ V}$ input range and serial output. Taking $\overline{\text{R/C}}$ (pin 22) LOW for 40 ns (12 μs max) will initiate a conversion and output valid data from the previous conversion on SDATA (pin 19) synchronized to 16 clock pulses output on DATACLK (pin 18). $\overline{\text{BUSY}}$ (pin 24) will go LOW and stay LOW until the conversion is completed and the serial data has been transmitted. Data will be output in BTC format, MSB first, and will be valid on both the rising and falling edges of the data clock. $\overline{\text{BUSY}}$ going HIGH can be used to latch the data. All convert commands will be ignored while $\overline{\text{BUSY}}$ is LOW.

The ADS8507 begins tracking the input signal at the end of the conversion. Allowing 25 μs between convert commands assures accurate acquisition of a new signal.

The offset and gain are adjusted internally to allow external trimming with a single supply. The external resistors compensate for this adjustment and can be left out if the offset and gain are corrected in software (refer to the Calibration section).

BASIC OPERATION (continued)

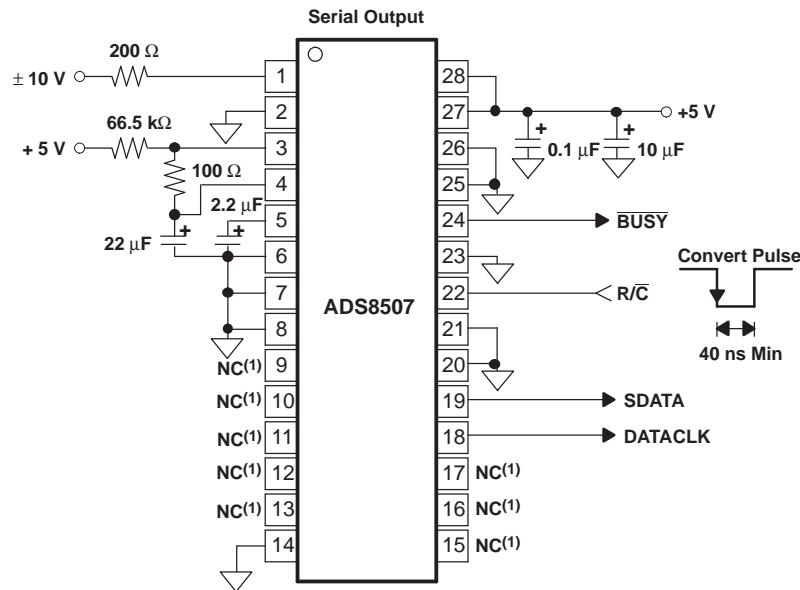

Figure 32. Basic ±10-V Operation With Serial Output

STARTING A CONVERSION

The combination of \overline{CS} (pin 23) and R/\overline{C} (pin 22) low for a minimum of 40 ns puts the sample-and-hold of the ADS8507 in the hold state and starts conversion N . \overline{BUSY} (pin 24) goes low and stays low until conversion N is completed and the internal output register has been updated. All new convert commands during \overline{BUSY} low are ignored. \overline{CS} and/or R/\overline{C} must go high before \overline{BUSY} goes high, or a new conversion is initiated without sufficient time to acquire a new signal.

The ADS8507 begins tracking the input signal at the end of the conversion. Allowing 25 μ s between convert commands assures accurate acquisition of a new signal. Refer to Table 2 and Table 3 for a summary of \overline{CS} , R/\overline{C} , and \overline{BUSY} states, and Figure 33, Figure 34, Figure 35, Figure 36, Figure 37, Figure 38, and Figure 39 for timing diagrams.

Table 2. Control Functions When Using Parallel Output (DATACLK Tied Low, $\overline{EXT}/\overline{INT}$ Tied High)

\overline{CS}	R/\overline{C}	\overline{BUSY}	OPERATION
1	X	X	None. Data bus is in Hi-Z state.
↓	0	1	Initiates conversion N . Data bus remains in Hi-Z state.
0	↓	1	Initiates conversion N . Databus enters Hi-Z state.
0	1	↑	Conversion N completed. Valid data from conversion N on the databus.
↓	1	1	Enables databus with valid data from conversion N .
↓	1	0	Enables databus with valid data from conversion $N-1^{(1)}$. Conversion N in progress.
0	↑	0	Enables databus with valid data from conversion $N-1^{(1)}$. Conversion N in progress.
0	0	↑	New conversion initiated without acquisition of a new signal. Data will be invalid. \overline{CS} and/or R/\overline{C} must be HIGH when \overline{BUSY} goes HIGH.
X	X	0	New convert commands ignored. Conversion N in progress.

(1) See Figure 33 and Figure 34 for constraints on data valid from conversion $N-1$.

\overline{CS} and R/\overline{C} are internally ORed and level triggered. It is not a requirement which input goes low first when initiating a conversion. If, however, it is critical that \overline{CS} or R/\overline{C} initiates conversion N , be sure the less critical input is low at least $t_{su2} \geq 10$ ns prior to the initiating input. If EXT/\overline{INT} (pin 8) is low when initiating conversion N , serial data from conversion $N-1$ is output on $SDATA$ (pin 19) following the start of conversion N . See Internal Data Clock in the Reading Data section.

To reduce the number of control pins, \overline{CS} can be tied low using R/\overline{C} to control the read and convert modes. This has no effect when using the internal data clock in the serial output mode. The parallel output and the serial output (only when using an external data clock), however, is affected whenever R/\overline{C} goes high and the external clock is active. Refer to the Reading Data section. In the internal clock mode data is clocked out every convert cycle regardless of the states of \overline{CS} and R/\overline{C} . The conversion result is available as soon as $BUSY$ returns to high therefore, data always represents the conversion previously completed even when it is read during a conversion.

READING DATA

The ADS8507 outputs serial or parallel data in straight binary (SB) or binary 2's complement data output format. If SB/\overline{BTC} (pin 7) is high, the output is in SB format, and if low, the output is in BTC format. Refer to Table 4 for ideal output codes. The first conversion immediately following a power-up does not produce a valid conversion result.

The parallel output can be read without affecting the internal output registers; however, reading the data through the serial port shifts the internal output registers one bit per data clock pulse. As a result, data can be read on the parallel port prior to reading the same data on the serial port, but data cannot be read through the serial port prior to reading the same data on the parallel port.

Table 3. Control Functions When Using Serial Output⁽¹⁾

\overline{CS}	R/\overline{C}	$BUSY$	EXT/\overline{INT}	$DATACLK$	OPERATION
↓	0	1	0	Output	Initiates conversion N . Valid data from conversion $N-1$ clocked out on $SDATA$.
0	↓	1	0	Output	Initiates conversion N . Valid data from conversion $N-1$ clocked out on $SDATA$.
↓	0	1	1	Input	Initiates conversion N . Internal clock still runs conversion process.
0	↓	1	1		Initiates conversion N . Internal clock still runs conversion process.
↓	1	1	1	Input	Conversion N completed. Valid data from conversion N clocked out on $SDATA$ synchronized to external data clock.
↓	1	0	1	Input	Valid data from conversion $N-1$ output on $SDATA$ synchronized to external data clock. Conversion N in progress.
0	↑	0	1	Input	Valid data from conversion $N-1$ output on $SDATA$ synchronized to external data clock. Conversion N in progress.
0	0	↑	X	Input	New conversion initiated without acquisition of a new signal. Data will be invalid. \overline{CS} and/or R/\overline{C} must be HIGH when $BUSY$ goes HIGH.
X	X	0	X	X	New convert commands ignored. Conversion N in progress..

(1) See Figure 37, Figure 38, and Figure 39 for constraints on data valid from conversion $N-1$.

Table 4. Output Codes and Ideal Input Voltages

DESCRIPTION	ANALOG INPUT			DIGITAL OUTPUT			
				BINARY 2's COMPLEMENT (SB/ \overline{BTC} LOW)		STRAIGHT BINARY (SB/ \overline{BTC} HIGH)	
				BINARY CODE	HEX CODE	BINARY CODE	HEX CODE
Full-scale range	±10	0 V to 5 V	0 V to 4 V				
Least significant bit (LSB)	305 μ V	76 μ V	61 μ V				
+Full-Scale (FS - 1LSB)	9.999695 V	4.999924 V	3.999939 V	0111 1111 1111 1111	7FFF	1111 1111 1111 1111	FFFF
Midscale	0 V	2.5 V	2 V	0000 0000 0000 0000	0000	1000 0000 0000 0000	8000
One LSB Below Midscale	305 μ V	2.499924 V	1.999939 V	1111 1111 1111 1111	FFFF	0111 1111 1111 1111	7FFF
-Full-Scale	-10 V	0 V	0 V	1000 0000 0000 0000	8000	0000 0000 0000 0000	0000

PARALLEL OUTPUT

To use the parallel output, tie $\overline{\text{EXT/INT}}$ (pin 8) high and DATACLK (pin 18) low. SDATA (pin 19) should be left unconnected. The parallel output is active when $\text{R}/\overline{\text{C}}$ (pin 22) is high and $\overline{\text{CS}}$ (pin 23) is low. Any other combination of $\overline{\text{CS}}$ and $\text{R}/\overline{\text{C}}$ 3-states the parallel output. Valid conversion data can be read in two 8-bit bytes on D7-D0 (pins 9-13 and 15-17). When BYTE (pin 21) is low, the 8 most significant bits will be valid with the MSB on D7. When BYTE is high, the 8 least significant bits are valid with the LSB on D0. BYTE can be toggled to read both bytes within one conversion cycle.

Upon initial power up, the parallel output contains indeterminate data.

PARALLEL OUTPUT (After a Conversion)

After conversion N is completed and the output registers have been updated, $\overline{\text{BUSY}}$ (pin 24) goes high. Valid data from conversion N is available on D7-D0 (pin 9-13 and 15-17). $\overline{\text{BUSY}}$ going high can be used to latch the data. Refer to Table 5 and Figure 33 and Figure 34 for timing specifications.

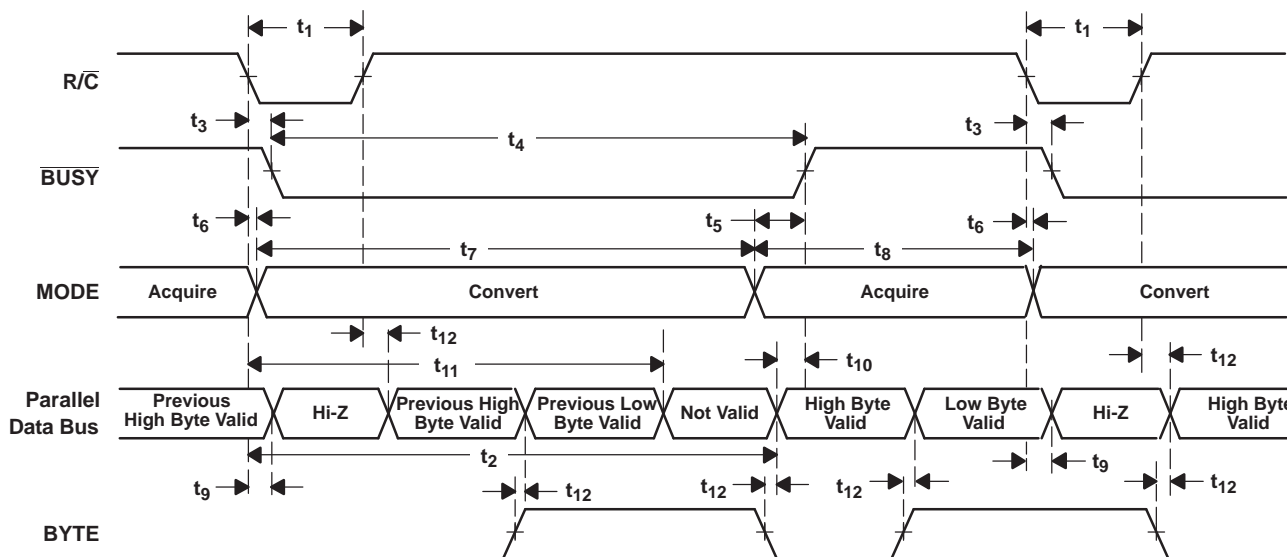

Figure 33. Conversion Timing With Parallel Output ($\overline{\text{CS}}$ and DATACLK Tied Low, $\overline{\text{EXT/INT}}$ Tied High)

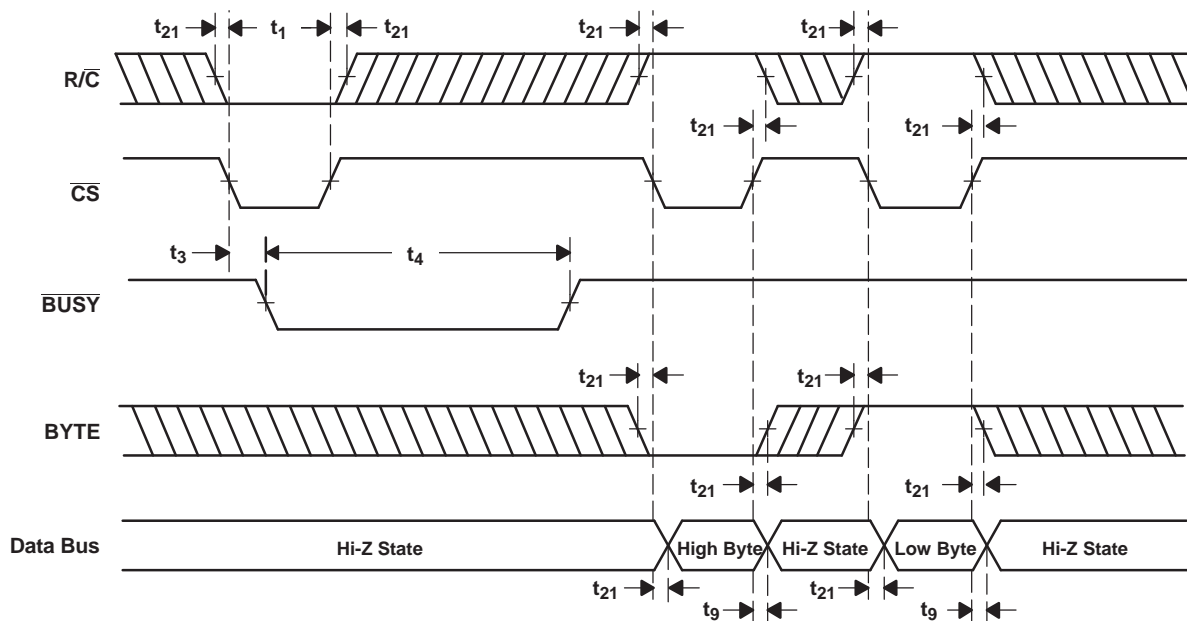

Figure 34. \overline{CS} to Control Conversion and Read Timing With Parallel Outputs

PARALLEL OUTPUT (During a Conversion)

After conversion N has been initiated, valid data from conversion $N-1$ can be read and is valid up to $12\ \mu\text{s}$ after the start of conversion N . Do not attempt to read data beyond $12\ \mu\text{s}$ after the start of conversion N until \overline{BUSY} (pin 24) goes high; this may result in reading invalid data. Refer to Table 5 and Figure 33 and Figure 34 for timing constraints.

Table 5. Conversion and Data Timing, $T_A = -40^\circ\text{C}$ to 85°C

SYMBOL	DESCRIPTION	MIN	TYP	MAX	UNITS
t_1	Convert pulse width	0.04		12	μs
t_2	Data valid delay after R/\overline{C} low		18	20	μs
t_3	\overline{BUSY} delay from start of conversion			85	ns
t_4	\overline{BUSY} Low		19	20	μs
t_5	\overline{BUSY} delay after end of conversion		90		ns
t_6	Aperture delay		40		ns
t_7	Conversion time	19	20		μs
t_8	Acquisition time		5		ns
t_9	Bus relinquish time	10		83	ns
t_{10}	\overline{BUSY} delay after data valid	20	60		ns
t_{11}	Previous data valid after start of conversion	12	18		μs
t_{12}	Bus access time and BYTE delay			83	ns
t_{13}	Start of conversion to DATACLK delay		1.4		μs
t_{14}	DATACLK period		1.1		μs
t_{15}	Data valid to DATACLK high delay	20	75		ns
t_{16}	Data valid after DATACLK low delay	400	600		ns
t_{17}	External DATACLK period	100			ns
t_{18}	External DATACLK low	40			ns
t_{19}	External DATACLK high	50			ns
t_{20}	\overline{CS} and R/\overline{C} to external DATACLK setup time	25			ns

Table 5. Conversion and Data Timing, $T_A = -40^\circ\text{C}$ to 85°C (continued)

t_{21}	R/ $\overline{\text{C}}$ to $\overline{\text{CS}}$ setup time	10	ns
t_{22}	Valid data after DATACLK high	25	ns
$t_7 + t_8$	Throughput time		25 μs

SERIAL OUTPUT

Data can be clocked out with the internal data clock or an external data clock. When using serial output, be careful with the parallel outputs, D7-D0 (pins 9-13 and 15-17), as these pins come out of Hi-Z state whenever $\overline{\text{CS}}$ (pin 23) is low and R/ $\overline{\text{C}}$ (pin 22) is high. The serial output cannot be 3-stated and is always active. Refer to the Applications Information section for specific serial interfaces. If external clock is used, the TAG input can be used to daisy-chain multiple ADS8507 data pins together.

INTERNAL DATA CLOCK (During a Conversion)

To use the internal data clock, tie EXT/ $\overline{\text{INT}}$ (pin 8) low. The combination of R/ $\overline{\text{C}}$ (pin 22) and CS (pin 23) low initiates conversion N and activates the internal data clock (typically 900-kHz clock rate). The ADS8507 outputs 16 bits of valid data, MSB first, from conversion $N-1$ on SDATA (pin 19), synchronized to 16 clock pulses output on DATACLK (pin 18). The data is valid on both the rising and falling edges of the internal data clock. The rising edge of $\overline{\text{BUSY}}$ (pin 24) can be used to latch the data. After the 16th clock pulse, DATACLK remains low until the next conversion is initiated, while SDATA returns to the state of the TAG pin input sensed at the start of transmission. Refer to [Table 6](#) and [Figure 36](#).

EXTERNAL DATA CLOCK

To use an external data clock, tie EXT/ $\overline{\text{INT}}$ (pin 8) high. The external data clock is not and cannot be synchronized with the internal conversion clock; care must be taken to avoid corrupting the data. To enable the output mode of the ADS8507, CS (pin 23) must be low and R/ $\overline{\text{C}}$ (pin 22) must be high. DATACLK must be high for 20% to 70% of the total data clock period; the clock rate can be between DC and 10 MHz. Serial data from conversion N can be output on SDATA (pin 19) after conversion N is completed or during conversion $N+1$.

An obvious way to simplify control of the converter is to tie $\overline{\text{CS}}$ low and use R/ $\overline{\text{C}}$ to initiate conversions.

While this is perfectly acceptable, there is a possible problem when using an external data clock. At an indeterminate point from 12 μs after the start of conversion N until $\overline{\text{BUSY}}$ rises, the internal logic shifts the results of conversion N into the output register. If $\overline{\text{CS}}$ is low, R/ $\overline{\text{C}}$ high, and the external clock is high at this point, data is lost. So, with $\overline{\text{CS}}$ low, either R/ $\overline{\text{C}}$ and/or DATACLK must be low during this period to avoid losing valid data.

EXTERNAL DATA CLOCK (After a Conversion)

After conversion N is completed and the output registers have been updated, $\overline{\text{BUSY}}$ (pin 24) goes high. With $\overline{\text{CS}}$ low and R/ $\overline{\text{C}}$ high, valid data from conversion N is output on SDATA (pin 19) synchronized to the external data clock input on DATACLK (pin 18). The MSB is valid on the first falling edge and the second rising edge of the external data clock. The LSB is valid on the 16th falling edge and 17th rising edge of the data clock. TAG (pin 20) inputs a bit of data for every external clock pulse. The first bit input on TAG is valid on SDATA on the 17th falling edge and the 18th rising edge of DATACLK; the second input bit is valid on the 18th falling edge and the 19th rising edge, etc. With a continuous data clock, TAG data is output on SDATA until the internal output registers are updated with the results from the next conversion. Refer to [Table 6](#) and [Figure 38](#).

EXTERNAL DATA CLOCK (During a Conversion)

After conversion N has been initiated, valid data from conversion $N-1$ can be read and is valid up to 12 μs after the start of conversion N . Do not attempt to clock out data from 12 μs after the start of conversion N until $\overline{\text{BUSY}}$ (pin 24) rises; this results in data loss. NOTE: For the best possible performance when using an external data clock, data should not be clocked out during a conversion. The switching noise of the asynchronous data clock can cause digital feedthrough degrading the converter's performance. Refer to [Table 6](#) and [Figure 39](#).

Table 6. Timing Requirements, $T_A = -40^\circ\text{C}$ to 85°C

PARAMETER		MIN	TYP	MAX	UNIT
t_{w1}	Pulse duration, convert	0.04		12	μs
t_{d1}	Delay time, $\overline{\text{BUSY}}$ from $\text{R}/\overline{\text{C}}$ low		12	20	ns
t_{w2}	Pulse duration, $\overline{\text{BUSY}}$ low		18	20	μs
t_{d2}	Delay time, $\overline{\text{BUSY}}$, after end of conversion		5		ns
t_{d3}	Delay time, aperture		5		ns
t_{conv}	Conversion time		18	20	μs
t_{acq}	Acquisition time	5	7		μs
$t_{\text{conv}} + t_{\text{acq}}$	Cycle time			25	μs
t_{d4}	Delay time, $\text{R}/\overline{\text{C}}$ low to internal DATACLK output		270		ns
t_{c1}	Cycle time, internal DATACLK	600	820	850	ns
t_{d5}	Delay time, data valid to internal DATACLK high	15	35		ns
t_{d6}	Delay time, data valid after internal DATACLK low	20	35		ns
t_{c2}	Cycle time, external DATACLK	35			ns
t_{w3}	Pulse duration, external DATACLK high	15			ns
t_{w4}	Pulse duration, external DATACLK low	15			ns
t_{su1}	Setup time, $\text{R}/\overline{\text{C}}$ rise/fall to external DATACLK high	15			ns
t_{su2}	Setup time, $\text{R}/\overline{\text{C}}$ transition to $\overline{\text{CS}}$ transition	10			ns
t_{d7}	Delay time, SYNC, after external DATACLK high	3		35	ns
t_{d8}	Delay time, data valid from external DATACLK high	2		20	ns
t_{d9}	Delay time, $\overline{\text{CS}}$ rising edge to external DATACLK rising edge	10			ns
t_{d10}	Delay time, previous data available after $\overline{\text{CS}}$, $\text{R}/\overline{\text{C}}$ low	2			μs
t_{su3}	Setup time, $\overline{\text{BUSY}}$ transition to first external DATACLK	5			ns
t_{d11}	Delay time, final external DATACLK to $\overline{\text{BUSY}}$ rising edge			1	μs
t_{su3}	Setup time, TAG valid	0			ns
t_{h1}	Hold time, TAG valid	2			ns

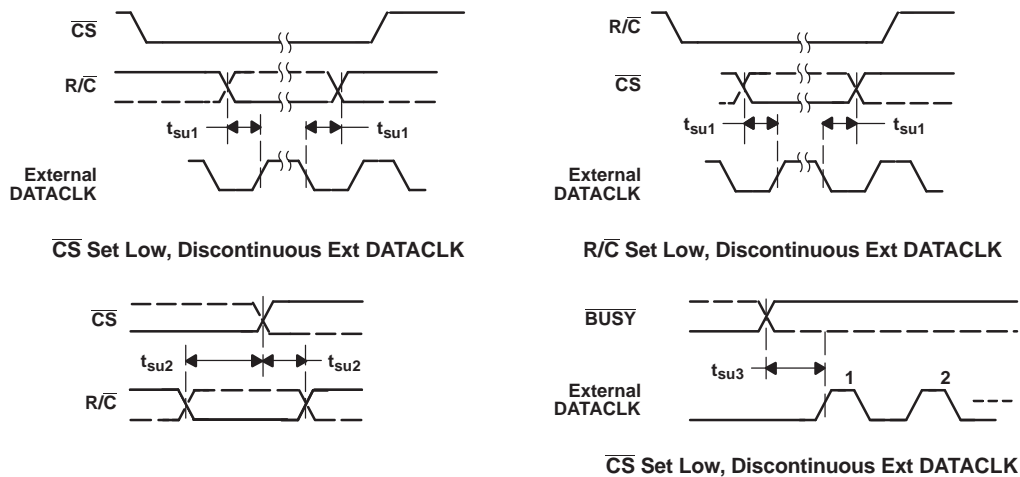

Figure 35. Critical Timing

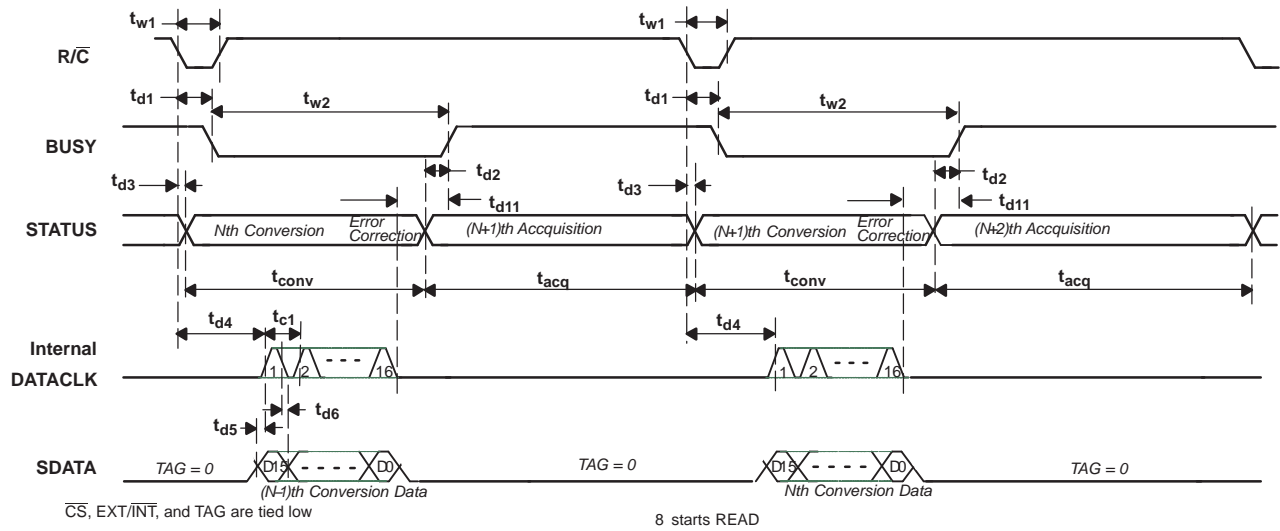

Figure 36. Basic Conversion Timing - Internal DATACLK (Read Previous Data During Conversion)

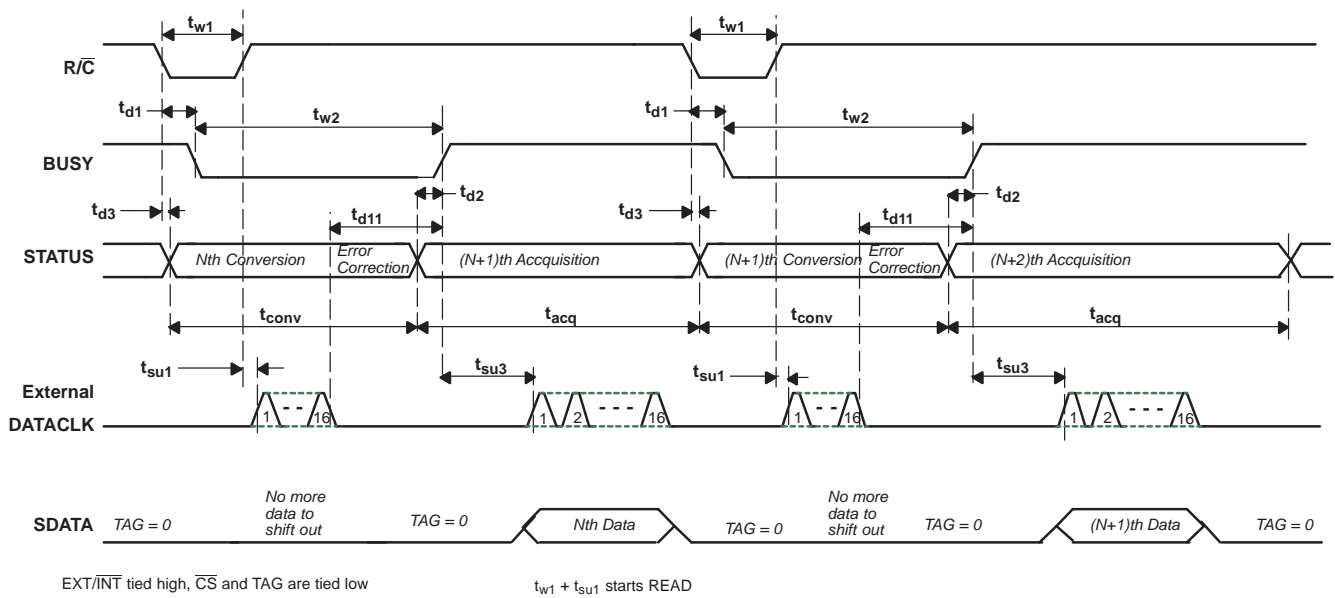

Figure 37. Basic Conversion Timing - External DATACLK

INPUT RANGES (continued)

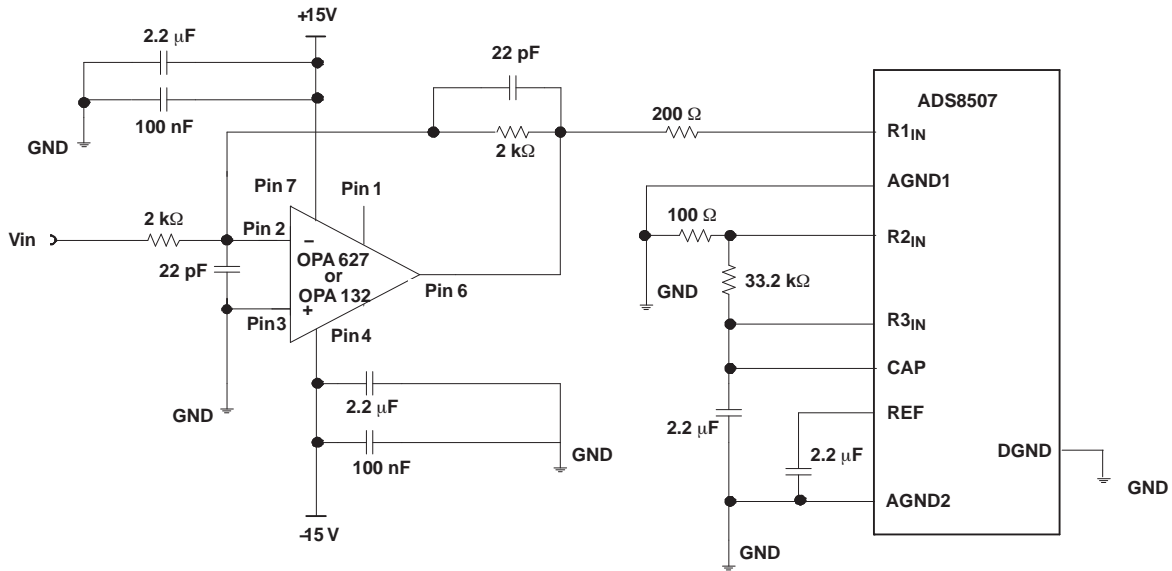

Figure 41. Typical Driving Circuit (± 10 V, No Trim)

CALIBRATION

Hardware Calibration

To calibrate the offset and gain of the ADS8507 in hardware, install the resistors shown in Figure 42. Table 7 lists the hardware trim ranges relative to the input for each input range.

Table 7. Offset and Gain Adjust Ranges for Hardware Calibration (see Figure 42)

INPUT RANGE	OFFSET ADJUST RANGE (mV)	GAIN ADJUST RANGE (mV)
± 10 V	± 15	± 60
0 V to 5 V	± 4	± 30
0 V to 4 V	± 3	± 30

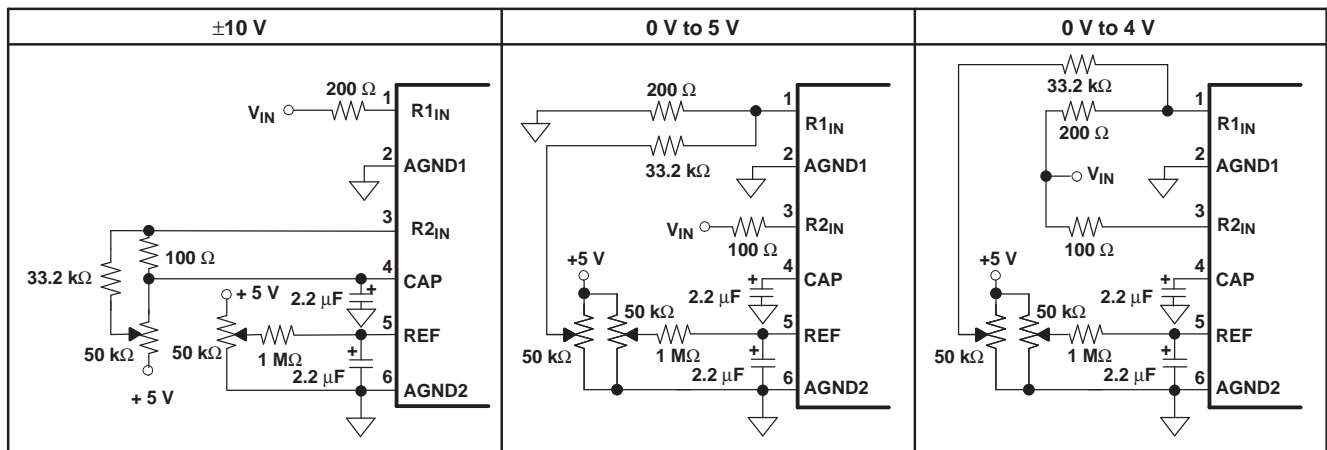

Figure 42. Circuit Diagrams (With Hardware Trim)

Software Calibration

To calibrate the offset and gain in software, no external resistors are required. However, to get the data sheet specifications for offset and gain, the resistors shown in Figure 43 are necessary. See the No Calibration section for more details on the external resistors. Refer to Table 8 for the range of offset and gain errors with and without the external resistors.

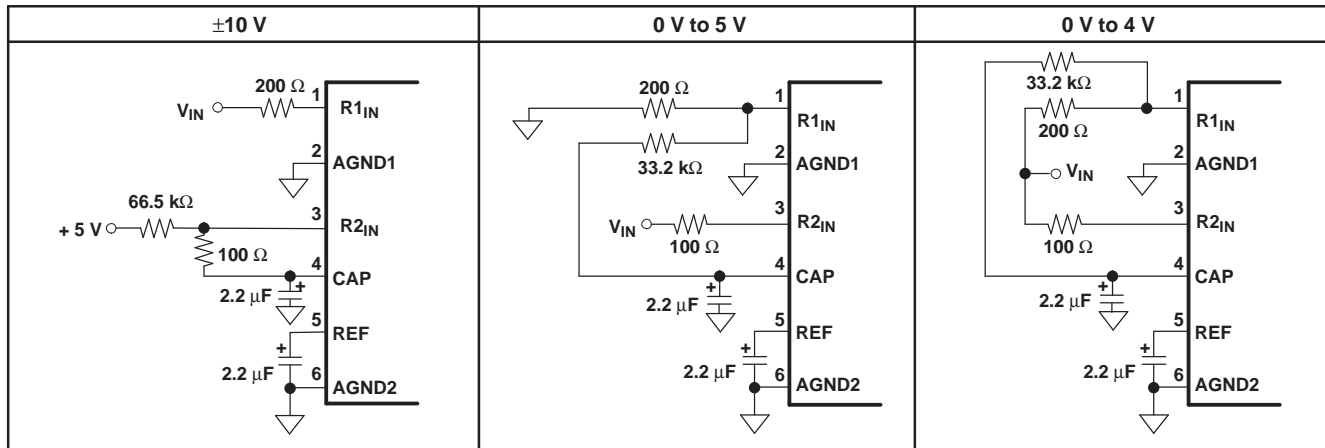

Figure 43. Circuit Diagrams (Without Hardware Trim)

Table 8. Range of Offset and Gain Errors With and Without External Resistors

INPUT RANGE (V)	OFFSET ERROR			GAIN ERROR		
	WITH RESISTORS	WITHOUT RESISTORS		WITH RESISTORS	WITHOUT RESISTORS	
	RANGE (mV)	RANGE (mV)	TYP (mV)	RANGE (% FS)	RANGE (% FS)	TYP
±10	-10 ≤ BPZ ≤ 10	0 ≤ BPZ ≤ 35	15	-0.4 ≤ G ≤ 0.4	-0.3 ≤ G ≤ 0.5	0.05
				0.15 ≤ G ⁽¹⁾ ≤ 0.15	-0.1 ≤ G ⁽¹⁾ ≤ 0.2	0.05
0 to 5	-3 ≤ UPO ≤ 3	-12 ≤ UPO ≤ -3	-7.5	-0.4 ≤ G ≤ 0.4	-1.0 ≤ G ≤ 0.1	-0.2
				0.15 ≤ G ⁽¹⁾ ≤ 0.1	-0.55 ≤ G ⁽¹⁾ ≤ -0.05	-0.2
0 to 4	-3 ≤ UPO ≤ 3	-10.5 ≤ UPO ≤ -1.5	-6	-0.4 ≤ G ≤ 0.4	-1.0 ≤ G ≤ 0.1	-0.2
				-0.15 ≤ G ⁽¹⁾ ≤ 0.15	-0.55 ≤ G ⁽¹⁾ ≤ -0.05	-0.2

(1) High grade

No Calibration

Figure 43 shows circuit connections. Note that the actual voltage dropped across the external resistors is at least two orders of magnitude lower than the voltage dropped across the internal resistor divider network. This should be considered when choosing the accuracy and drift specifications of the external resistors. In most applications, 1% metal-film resistors are sufficient.

The external resistors, see Figure 43, may not be necessary in some applications. These resistors provide compensation for an internal adjustment of the offset and gain which allows calibration with a single supply. Not using the external resistors results in offset and gain errors in addition to those listed in the electrical characteristics section. Offset refers to the equivalent voltage of the digital output when converting with the input grounded. A positive gain error occurs when the equivalent output voltage of the digital output is larger than the analog input. Refer to Table 8 for nominal ranges of gain and offset errors with and without the external resistors. Refer to Figure 44 for typical shifts in the transfer functions which occur when the external resistors are removed.

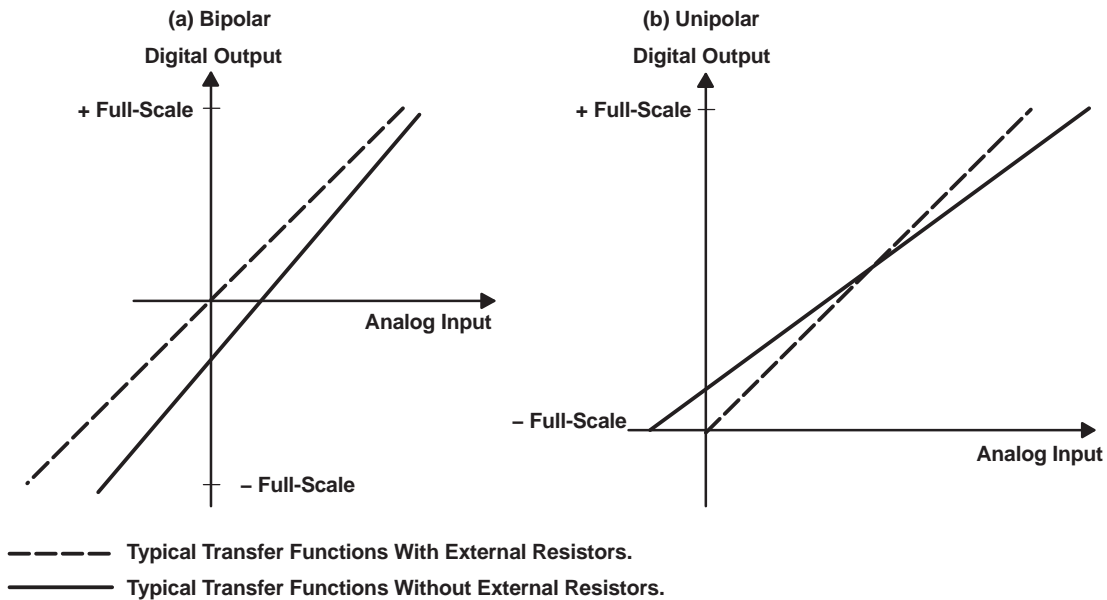

Figure 44. Typical Transfer Functions With and Without External Resistors

To further analyze the effects of removing any combination of the external resistors, consider Figure 45. The combination of the external and the internal resistors form a voltage divider which reduces the input signal to a 0.3125-V to 2.8125-V input range at the capacitor digital-to-analog converter (CDAC). The internal resistors are laser trimmed to high relative accuracy to meet full-scale specifications. The actual input impedance of the internal resistor network looking into pin 1 or pin 3 however, is only accurate to $\pm 20\%$ due to process variations. This should be taken into account when determining the effects of removing the external resistors.

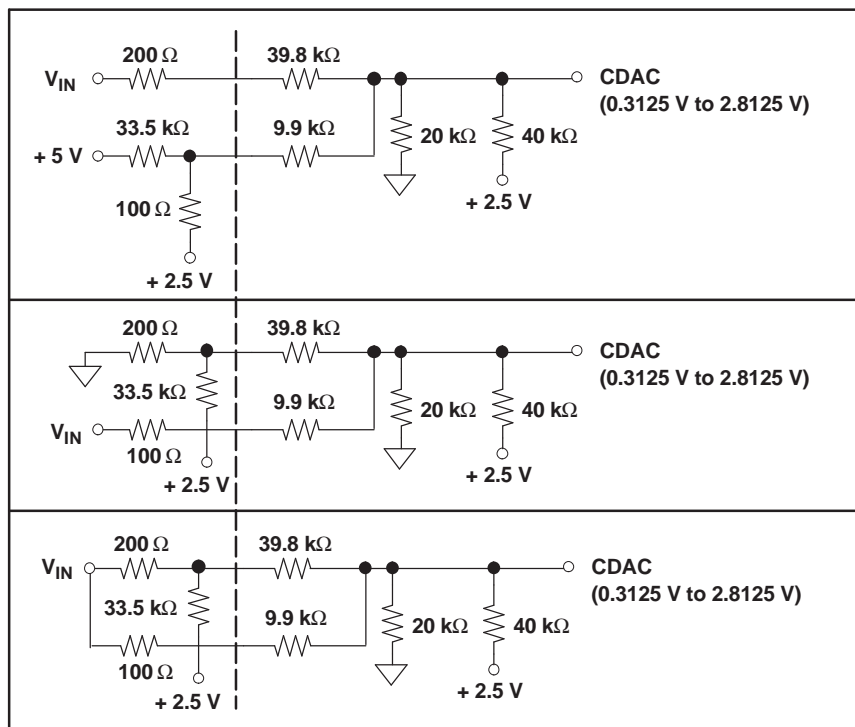

Figure 45. Circuit Diagrams Showing External and Internal Resistors

REFERENCE

The ADS8507 can operate with its internal 2.5-V reference or an external reference. By applying an external reference to pin 5, the internal reference can be bypassed. The reference voltage at REF is buffered internally with the output on CAP (pin 4).

The internal reference has an 8 ppm/°C drift (typical) and accounts for approximately 20% of the full-scale error (FSE = ±0.5% for low grade, ±0.25% for high grade).

The ADS8507 also has an internal buffer for the reference voltage. Figure 46 shows characteristic impedances at the input and output of the buffer with all combinations of powerdown and reference down.

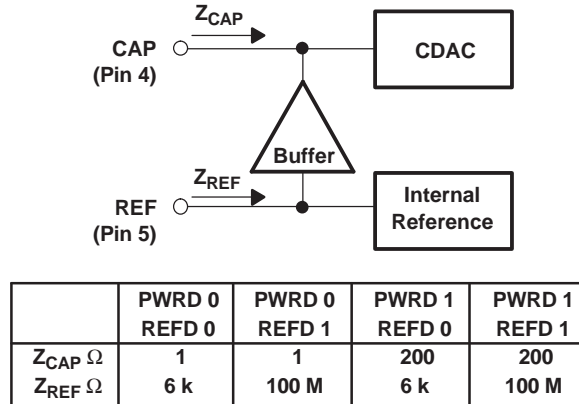

Figure 46. Characteristic Impedances of the Internal Buffer

REF

REF (pin 5) is an input for an external reference or the output for the internal 2.5-V reference. A 2.2-μF tantalum capacitor should be connected as close as possible to the REF pin from ground. This capacitor and the output resistance of REF create a low-pass filter to bandlimit noise on the reference. Using a smaller value capacitor will introduce more noise to the reference, degrading the SNR and SINAD. The REF pin should not be used to drive external AC or DC loads, as shown in Figure 46.

The range for the external reference is 2.3 V to 2.7 V and determines the actual LSB size. Increasing the reference voltage increases the full-scale range and the LSB size of the converter which can improve the SNR.

CAP

CAP (pin 4) is the output of the internal reference buffer. A 2.2-μF tantalum capacitor should be placed as close as possible to the CAP pin from ground to provide optimum switching currents for the CDAC throughout the conversions cycle. This capacitor also provides compensation for the output of the buffer. Using a capacitor any smaller than 1 μF can cause the output buffer to oscillate and may not have sufficient charge for the CDAC. Capacitor values larger than 2.2 μF have little affect on improving performance. ESR is the total equivalent series resistance of the compensation capacitor (CAP pin). See Figure 46 and Figure 47.

REFERENCE (continued)

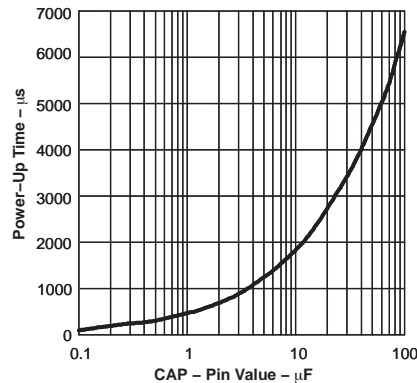

Figure 47. Power-Down to Power-Up Time vs Capacitor Value on CAP

The output of the buffer is capable of driving up to 1 mA of current to a DC load. Using an external buffer allows the internal reference to be used for larger DC loads and AC loads. Do not attempt to directly drive an AC load with the output voltage on CAP. This causes performance degradation of the converter.

REFERENCE AND POWER-DOWN

The ADS8507 has analog power-down and reference power down capabilities via PWRD (pin 25) and REFD (pin 26), respectively. PWRD and REFD high powers down all analog circuitry maintaining data from the previous conversion in the internal registers, provided that the data has not already been shifted out through the serial port. Typical power consumption in this mode is 50 µW. Power recovery is typically 1 ms, using a 2.2-µF capacitor connected to CAP. Figure 47 shows power-down to power-up recovery time relative to the capacitor value on CAP. With +5 V applied to V_{DIG}, the digital circuitry of the ADS8507 remains active at all times, regardless of PWRD and REFD states.

PWRD

PWRD high powers down all of the analog circuitry except for the reference. Data from the previous conversion is maintained in the internal registers and can still be read. With PWRD high, a convert command yields meaningless data.

REFD

REFD high powers down the internal 2.5-V reference. All other analog circuitry, including the reference buffer, is active. REFD should be high when using an external reference to minimize power consumption and the loading effects on the external reference. See Figure 46 for the characteristic impedance of the reference buffer's input for both REFD high and low. The internal reference consumes approximately 5 mW.

LAYOUT

POWER

For optimum performance, tie the analog and digital power pins to the same +5-V power supply and tie the analog and digital grounds together. As noted in the electrical characteristics, the ADS8507 uses 90% of its power for the analog circuitry. The ADS8507 should be considered as an analog component.

The +5-V power for the A/D converter should be separate from the +5 V used for the system's digital logic. Connecting V_{DIG} (pin 28) directly to a digital supply can reduce converter performance due to switching noise

LAYOUT (continued)

from the digital logic. For best performance, the +5-V supply can be produced from whatever analog supply is used for the rest of the analog signal conditioning. If +12-V or +15-V supplies are present, a simple +5-V regulator can be used. Although it is not suggested, if the digital supply must be used to power the converter, be sure to properly filter the supply. Either using a filtered digital supply or a regulated analog supply, both V_{DIG} and V_{ANA} should be tied to the same +5-V source.

GROUNDING

Three ground pins are present on the ADS8507. DGND is the digital supply ground. AGND2 is the analog supply ground. AGND1 is the ground to which all analog signals internal to the A/D converter are referenced. AGND1 is more susceptible to current induced voltage drops and must have the path of least resistance back to the power supply.

All the ground pins of the A/D converter should be tied to an analog ground plane, separated from the system's digital logic ground, to achieve optimum performance. Both analog and digital ground planes should be tied to the *system* ground as near to the power supplies as possible. This helps to prevent dynamic digital ground currents from modulating the analog ground through a common impedance to power ground.

SIGNAL CONDITIONING

The FET switches used for the sample hold on many CMOS A/D converters release a significant amount of charge injection which can cause the driving op amp to oscillate. The amount of charge injection due to the sampling FET switch on the ADS8507 is approximately 5% to 10% of the amount on similar A/D converters with the charge redistribution digital-to-analog converter (DAC) CDAC architecture. There is also a resistive front end which attenuates any charge which is released. The end result is a minimal requirement for the drive capability on the signal conditioning preceding the A/D converter. Any op amp sufficient for the signal in an application will be sufficient to drive the ADS8507.

The resistive front end of the ADS8507 also provides a specified ± 25 -V overvoltage protection. In most cases, this eliminates the need for external over-voltage protection circuitry.

INTERMEDIATE LATCHES

The ADS8507 does have 3-state outputs for the parallel port, but intermediate latches should be used if the bus is active during conversions. If the bus is not active during conversion, the 3-state outputs can be used to isolate the A/D converter from other peripherals on the same bus.

Intermediate latches are beneficial on any monolithic A/D converter. The ADS8507 has an internal LSB size of 38 μ V. Transients from fast switching signals on the parallel port, even when the A/D converter is 3-stated, can be coupled through the substrate to the analog circuitry causing degradation of converter performance.

APPLICATION INFORMATION

TRANSITION NOISE

Apply a DC input to the ADS8507 and initiate 1000 conversions. The digital output of the converter varies in output codes due to the internal noise of the ADS8507. This is true for all 16-bit SAR converters. The transition noise specification found in the electrical characteristics section is a statistical figure which represents the one sigma limit or rms value of these output codes.

Using a histogram to plot the output codes, the distribution should appear bell-shaped with the peak of the bell curve representing the nominal output code for the input voltage value. The $\pm 1\sigma$, $\pm 2\sigma$, and $\pm 3\sigma$ distributions represent 68.3%, 95.5%, and 99.7% of all codes. Multiplying TN by 6 yields the $\pm 3\sigma$ distribution or 99.7% of all codes. Statistically, up to 3 codes could fall outside the 5 code distribution when executing 1000 conversions. The ADS8507 has a TN of 0.8 LSBs which yields 5 output codes for a $\pm 3\sigma$ distribution. Figure 48 shows 16384 conversion histogram results.

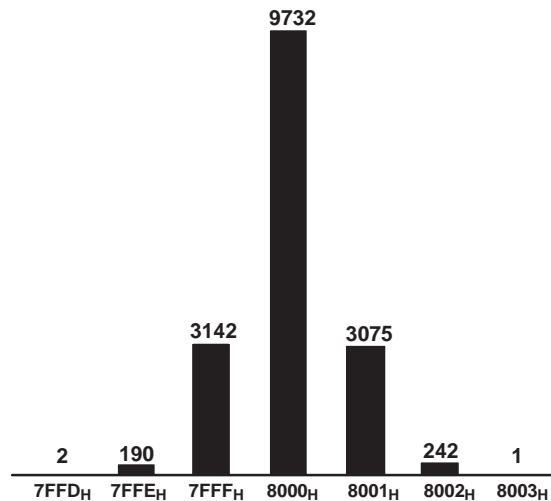

Figure 48. Histogram of 16384 Conversions with $V_{IN} = 0$ V in ± 10 V Bipolar Range

AVERAGING

The noise of the converter can be compensated by averaging the digital codes. By averaging conversion results, transition noise is reduced by a factor of $1/\sqrt{n}$ where n is the number of averages. For example, averaging four conversion results reduces the TN by $\frac{1}{2}$ to 0.4 LSBs. Averaging should only be used for input signals with frequencies near DC.

For AC signals, a digital filter can be used to low-pass filter and decimate the output codes. This works in a similar manner to averaging: for every decimation by 2, the signal-to-noise ratio improves 3 dB.

QSPI™ INTERFACE

Figure 49 shows a simple interface between the ADS8507 and any QSPI equipped microcontroller. This interface assumes that the convert pulse does not originate from the microcontroller and that the ADS8507 is the only serial peripheral.

APPLICATION INFORMATION (continued)

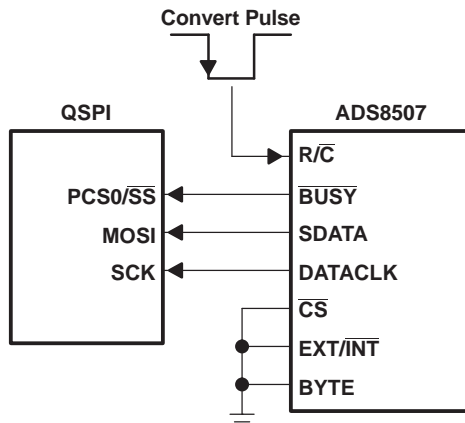

CPOL = 0 (Inactive State is LOW)
CPHA = 1 (Data Valid on Falling Edge)
QSPI Port is in Slave Mode.

Figure 49. QSPI Interface to the ADS8507

Before enabling the QSPI interface, the microcontroller must be configured to monitor the slave select line. When a transition from low to high occurs on slave select (\overline{SS}) from \overline{BUSY} (indicating the end of the current conversion), the port can be enabled. If this is not done, the microcontroller and the A/D converter may be *out-of-sync*.

Figure 50 shows another interface between the ADS8507 and a QSPI equipped microcontroller which allows the microcontroller to give the convert pulses while also allowing multiple peripherals to be connected to the serial bus. This interface and the following discussion assume a master clock for the QSPI interface of 16.78 MHz. Notice that the serial data input of the microcontroller is tied to the MSB (D7) of the ADS8507 instead of the serial output (SDATA). Using D7 instead of the serial port offers 3-state capability which allows other peripherals to be connected to the MISO pin. When communication is desired with those peripherals, PCS0 and PCS1 should be left high; that keeps D7 3-stated.

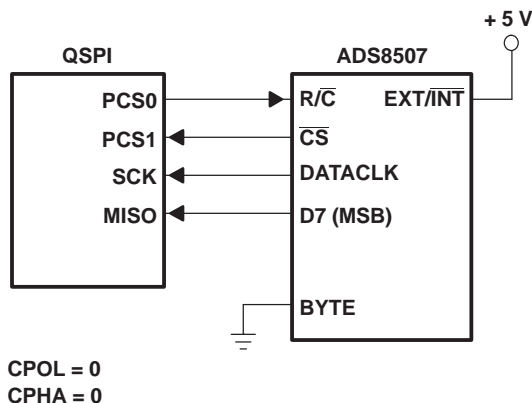

CPOL = 0
CPHA = 0

Figure 50. QSPI Interface to the ADS8507, Processor Initiates Conversions

In this configuration, the QSPI interface is actually set to do two different serial transfers. The first, an 8-bit transfer, causes PCS0 ($\overline{R/C}$) and PCS1 (\overline{CS}) to go low, starting a conversion. The second, a 16-bit transfer, causes only PCS1 (\overline{CS}) to go low. This is when the valid data is transferred.

For both transfers, the DT register (delay after transfer) is used to cause a 19- μ s delay. The interface is also set up to wrap to the beginning of the queue. In this manner, the QSPI is a state machine which generates the appropriate timing for the ADS8507. This timing is thus locked to the crystal-based timing of the microcontroller and not interrupt driven. So, this interface is appropriate for both AC and DC measurements.

APPLICATION INFORMATION (continued)

For the fastest conversion rate, the baud rate should be set to 2 (4.19-MHz SCK), DT set to 10, the first serial transfer set to 8 bits, the second set to 16 bits, and DSCK disabled (in the command control byte). This allows for a 23-kHz maximum conversion rate. For slower rates, DT should be increased. Do not slow SCK as this may increase the chance of affecting the conversion results or accidentally initiating a second conversion during the first 8-bit transfer.

In addition, CPOL and CPHA should be set to zero (SCK normally low and data captured on the rising edge). The command control byte for the 8-bit transfer should be set to 20_H and for the 16-bit transfer to 61_H.

SPI™ INTERFACE

The SPI interface is generally only capable of 8-bit data transfers. For some microcontrollers with SPI interfaces, it might be possible to receive data in a similar manner as shown for the QSPI interface in [Figure 49](#). The microcontroller needs to fetch the 8 most significant bits before the contents are overwritten by the least significant bits.

A modified version of the QSPI interface shown in [Figure 50](#) might be possible. For most microcontrollers with a SPI interface, the automatic generation of the start-of-conversion pulse is impossible and has to be done with software. This limits the interface to DC applications due to the insufficient jitter performance of the convert pulse itself.

PACKAGING INFORMATION

Orderable Device	Status (1)	Package Type	Package Drawing	Pins	Package Qty	Eco Plan (2)	Lead finish/ Ball material (6)	MSL Peak Temp (3)	Op Temp (°C)	Device Marking (4/5)	Samples
ADS8507IBDW	ACTIVE	SOIC	DW	28	20	RoHS & Green	NIPDAU	Level-2-260C-1 YEAR	-40 to 85	ADS8507I B	Samples
ADS8507IBDWG4	ACTIVE	SOIC	DW	28	20	RoHS & Green	NIPDAU	Level-2-260C-1 YEAR	-40 to 85	ADS8507I B	Samples
ADS8507IBDWR	ACTIVE	SOIC	DW	28	1000	RoHS & Green	NIPDAU	Level-2-260C-1 YEAR	-40 to 85	ADS8507I B	Samples
ADS8507IDW	ACTIVE	SOIC	DW	28	20	RoHS & Green	NIPDAU	Level-2-260C-1 YEAR	-40 to 85	ADS8507I	Samples
ADS8507IDWG4	ACTIVE	SOIC	DW	28	20	RoHS & Green	NIPDAU	Level-2-260C-1 YEAR	-40 to 85	ADS8507I	Samples
ADS8507IDWR	ACTIVE	SOIC	DW	28	1000	RoHS & Green	NIPDAU	Level-2-260C-1 YEAR	-40 to 85	ADS8507I	Samples
ADS8507IDWRG4	ACTIVE	SOIC	DW	28	1000	RoHS & Green	NIPDAU	Level-2-260C-1 YEAR	-40 to 85	ADS8507I	Samples

(1) The marketing status values are defined as follows:

ACTIVE: Product device recommended for new designs.

LIFEBUY: TI has announced that the device will be discontinued, and a lifetime-buy period is in effect.

NRND: Not recommended for new designs. Device is in production to support existing customers, but TI does not recommend using this part in a new design.

PREVIEW: Device has been announced but is not in production. Samples may or may not be available.

OBSOLETE: TI has discontinued the production of the device.

(2) **RoHS:** TI defines "RoHS" to mean semiconductor products that are compliant with the current EU RoHS requirements for all 10 RoHS substances, including the requirement that RoHS substance do not exceed 0.1% by weight in homogeneous materials. Where designed to be soldered at high temperatures, "RoHS" products are suitable for use in specified lead-free processes. TI may reference these types of products as "Pb-Free".

RoHS Exempt: TI defines "RoHS Exempt" to mean products that contain lead but are compliant with EU RoHS pursuant to a specific EU RoHS exemption.

Green: TI defines "Green" to mean the content of Chlorine (Cl) and Bromine (Br) based flame retardants meet JS709B low halogen requirements of <=1000ppm threshold. Antimony trioxide based flame retardants must also meet the <=1000ppm threshold requirement.

(3) MSL, Peak Temp. - The Moisture Sensitivity Level rating according to the JEDEC industry standard classifications, and peak solder temperature.

(4) There may be additional marking, which relates to the logo, the lot trace code information, or the environmental category on the device.

(5) Multiple Device Markings will be inside parentheses. Only one Device Marking contained in parentheses and separated by a "-" will appear on a device. If a line is indented then it is a continuation of the previous line and the two combined represent the entire Device Marking for that device.

⁽⁶⁾ Lead finish/Ball material - Orderable Devices may have multiple material finish options. Finish options are separated by a vertical ruled line. Lead finish/Ball material values may wrap to two lines if the finish value exceeds the maximum column width.

Important Information and Disclaimer:The information provided on this page represents TI's knowledge and belief as of the date that it is provided. TI bases its knowledge and belief on information provided by third parties, and makes no representation or warranty as to the accuracy of such information. Efforts are underway to better integrate information from third parties. TI has taken and continues to take reasonable steps to provide representative and accurate information but may not have conducted destructive testing or chemical analysis on incoming materials and chemicals. TI and TI suppliers consider certain information to be proprietary, and thus CAS numbers and other limited information may not be available for release.

In no event shall TI's liability arising out of such information exceed the total purchase price of the TI part(s) at issue in this document sold by TI to Customer on an annual basis.

TAPE AND REEL INFORMATION

QUADRANT ASSIGNMENTS FOR PIN 1 ORIENTATION IN TAPE



*All dimensions are nominal

Device	Package Type	Package Drawing	Pins	SPQ	Reel Diameter (mm)	Reel Width W1 (mm)	A0 (mm)	B0 (mm)	K0 (mm)	P1 (mm)	W (mm)	Pin1 Quadrant
ADS8507IBDWR	SOIC	DW	28	1000	330.0	32.4	11.35	18.67	3.1	16.0	32.0	Q1
ADS8507IDWR	SOIC	DW	28	1000	330.0	32.4	11.35	18.67	3.1	16.0	32.0	Q1

TAPE AND REEL BOX DIMENSIONS

*All dimensions are nominal

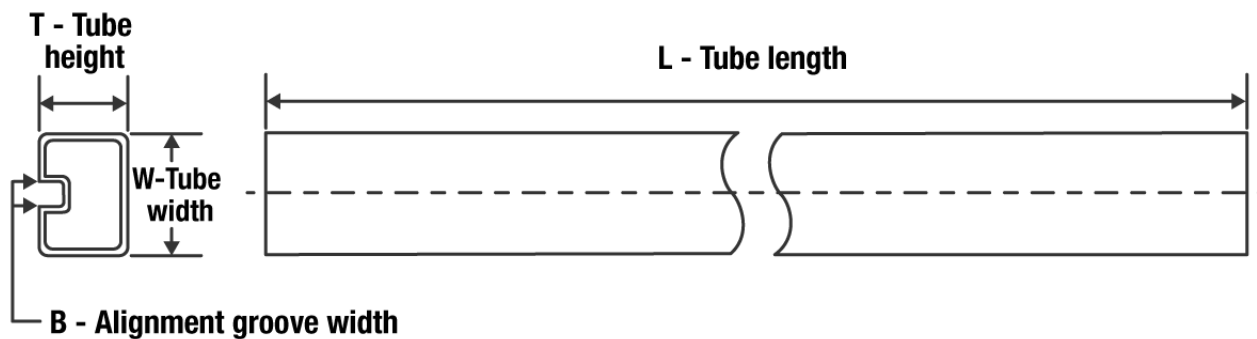
Device	Package Type	Package Drawing	Pins	SPQ	Length (mm)	Width (mm)	Height (mm)
ADS8507IBDWR	SOIC	DW	28	1000	350.0	350.0	66.0
ADS8507IDWR	SOIC	DW	28	1000	350.0	350.0	66.0

TUBE

*All dimensions are nominal

Device	Package Name	Package Type	Pins	SPQ	L (mm)	W (mm)	T (μm)	B (mm)
ADS8507IBDW	DW	SOIC	28	20	506.98	12.7	4826	6.6
ADS8507IBDWG4	DW	SOIC	28	20	506.98	12.7	4826	6.6
ADS8507IDW	DW	SOIC	28	20	506.98	12.7	4826	6.6
ADS8507IDWG4	DW	SOIC	28	20	506.98	12.7	4826	6.6

DW (R-PDSO-G28)

PLASTIC SMALL OUTLINE

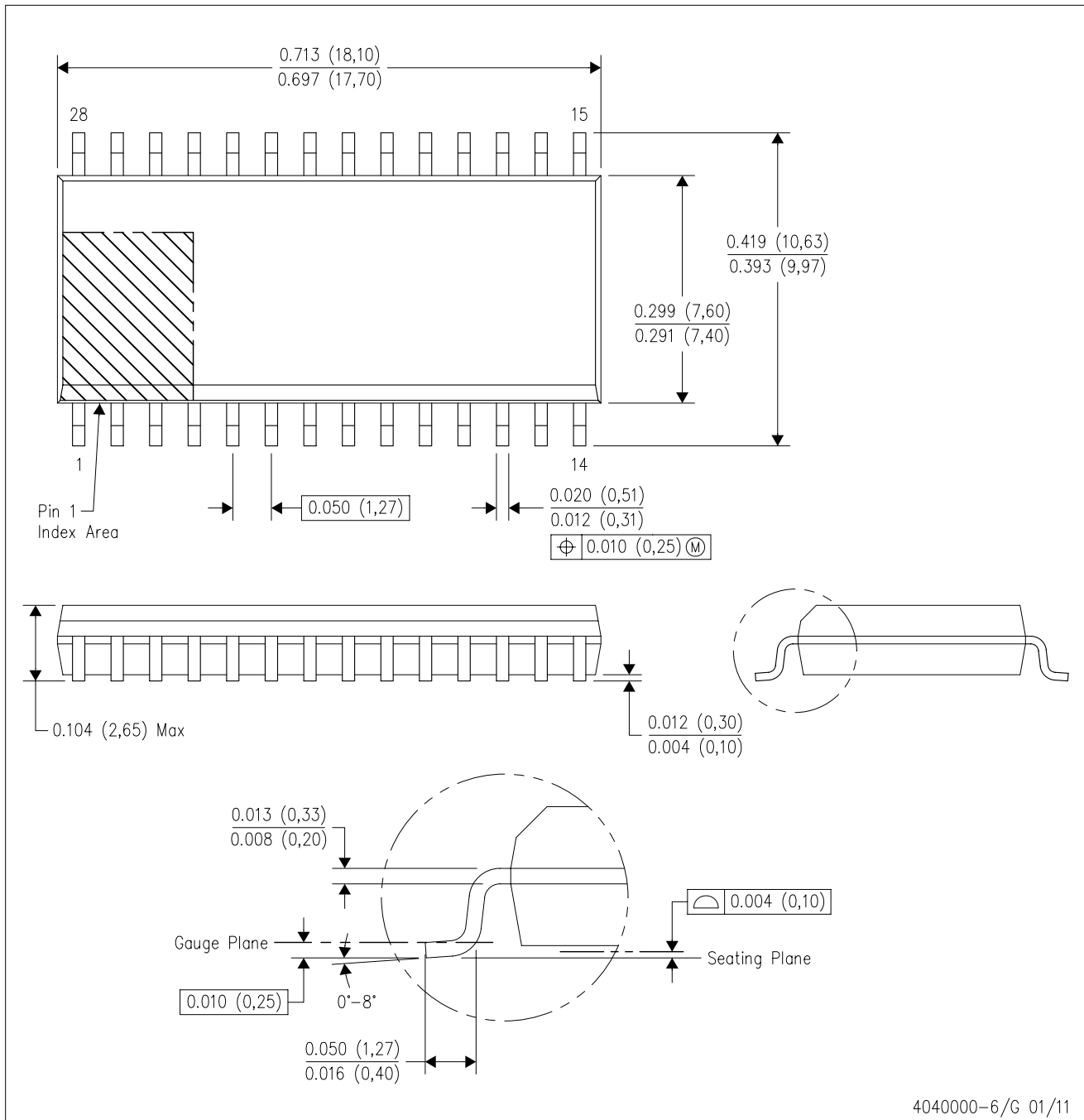

4040000-6/G 01/11

- NOTES:
- All linear dimensions are in inches (millimeters). Dimensioning and tolerancing per ASME Y14.5M-1994.
 - This drawing is subject to change without notice.
 - Body dimensions do not include mold flash or protrusion not to exceed 0.006 (0,15).
 - Falls within JEDEC MS-013 variation AE.

DW (R-PDSO-G28)

PLASTIC SMALL OUTLINE

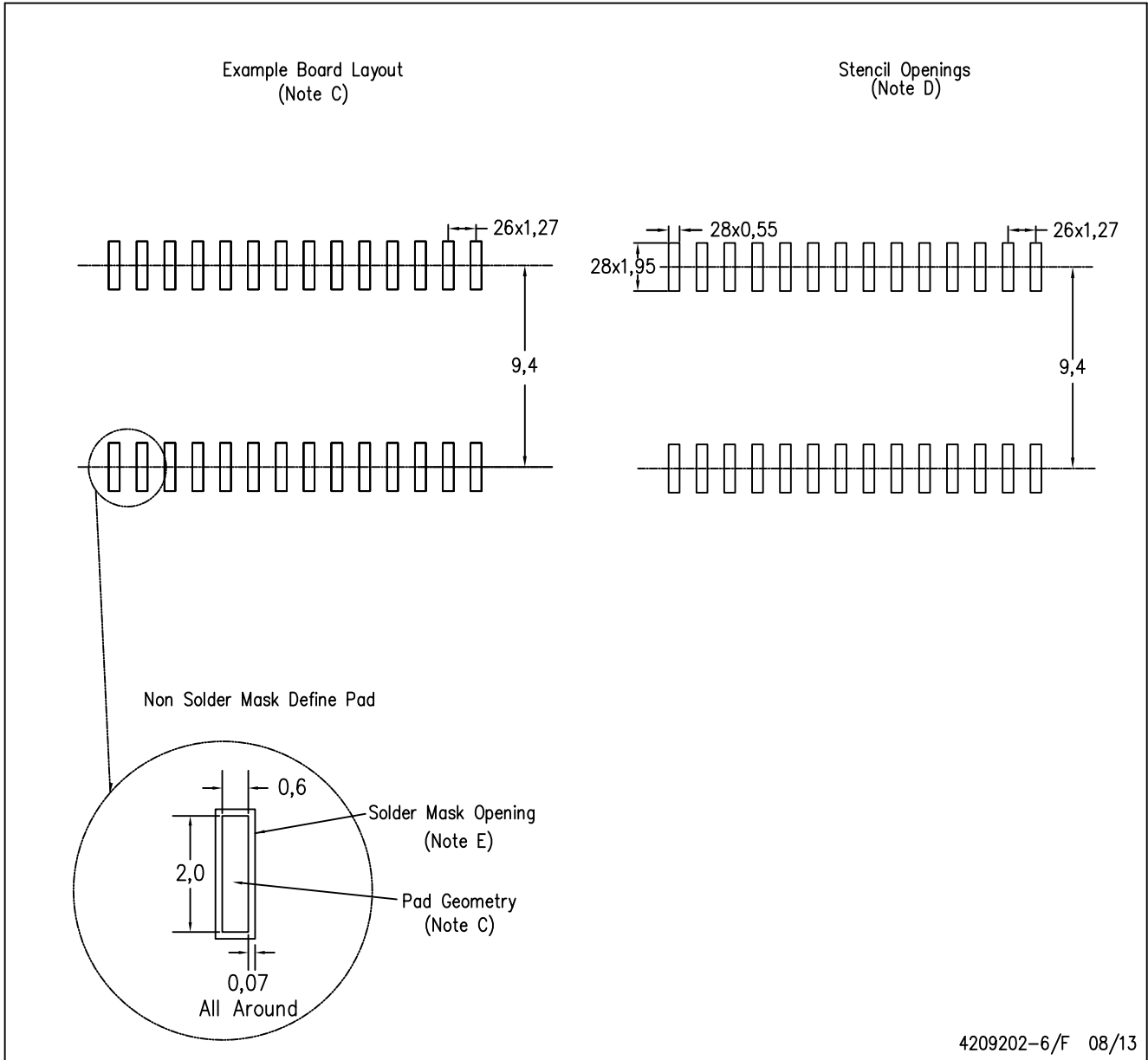

- NOTES:
- A. All linear dimensions are in millimeters.
 - B. This drawing is subject to change without notice.
 - C. Refer to IPC7351 for alternate board design.
 - D. Laser cutting apertures with trapezoidal walls and also rounding corners will offer better paste release. Customers should contact their board assembly site for stencil design recommendations. Refer to IPC-7525
 - E. Customers should contact their board fabrication site for solder mask tolerances between and around signal pads.

IMPORTANT NOTICE AND DISCLAIMER

TI PROVIDES TECHNICAL AND RELIABILITY DATA (INCLUDING DATA SHEETS), DESIGN RESOURCES (INCLUDING REFERENCE DESIGNS), APPLICATION OR OTHER DESIGN ADVICE, WEB TOOLS, SAFETY INFORMATION, AND OTHER RESOURCES "AS IS" AND WITH ALL FAULTS, AND DISCLAIMS ALL WARRANTIES, EXPRESS AND IMPLIED, INCLUDING WITHOUT LIMITATION ANY IMPLIED WARRANTIES OF MERCHANTABILITY, FITNESS FOR A PARTICULAR PURPOSE OR NON-INFRINGEMENT OF THIRD PARTY INTELLECTUAL PROPERTY RIGHTS.

These resources are intended for skilled developers designing with TI products. You are solely responsible for (1) selecting the appropriate TI products for your application, (2) designing, validating and testing your application, and (3) ensuring your application meets applicable standards, and any other safety, security, regulatory or other requirements.

These resources are subject to change without notice. TI grants you permission to use these resources only for development of an application that uses the TI products described in the resource. Other reproduction and display of these resources is prohibited. No license is granted to any other TI intellectual property right or to any third party intellectual property right. TI disclaims responsibility for, and you will fully indemnify TI and its representatives against, any claims, damages, costs, losses, and liabilities arising out of your use of these resources.

TI's products are provided subject to [TI's Terms of Sale](#) or other applicable terms available either on ti.com or provided in conjunction with such TI products. TI's provision of these resources does not expand or otherwise alter TI's applicable warranties or warranty disclaimers for TI products.

TI objects to and rejects any additional or different terms you may have proposed.

Mailing Address: Texas Instruments, Post Office Box 655303, Dallas, Texas 75265
Copyright © 2022, Texas Instruments Incorporated