

# INA190-Q1 汽车类、40V、高精度、低偏置电流、低功耗 电流检测放大器

## 1 特性

- 具有符合面向汽车应用的 AEC-Q100 标准：
  - 温度等级 1:  $-40^{\circ}\text{C}$  至  $+125^{\circ}\text{C}$ ,  $T_A$
- 低输入偏置电流: 500pA (典型值)  
(支持微安级电流测量)
- 低功耗：
  - 低电源电压  $V_S$ : 1.7V 至 5.5V
  - 低静态电流:  $25^{\circ}\text{C}$  下为  $50\mu\text{A}$  (典型值)
- 精度：
  - 增益误差:  $\pm 0.2\%$  (A1 器件)
  - 增益漂移:  $5\text{ppm}/^{\circ}\text{C}$  (最大值)
  - 失调电压  $V_{OS}$ :  $\pm 15\mu\text{V}$  (最大值)
  - 温漂:  $0.13\mu\text{V}/^{\circ}\text{C}$  (最大值)
- 宽共模电压:  $-0.2\text{V}$  至  $+40\text{V}$ , 可承受高达 42V 的电压
- 双向电流检测功能
- 增益选项：
  - INA190A1-Q1: 25V/V
  - INA190A2-Q1: 50V/V
  - INA190A3-Q1: 100V/V
  - INA190A4-Q1: 200V/V
  - INA190A5-Q1: 500V/V

## 2 应用

- 车身控制模块 (BCM)
- 远程信息处理控制单元
- 紧急呼叫 (eCall)
- 12V 电池管理系统 (BMS)
- 汽车音响主机

## 3 说明

INA190-Q1 是一款汽车类低功耗、电压输出、电流分流监控器 (也称为电流检测放大器)。此器件常用于监控直接连接到汽车类 12V 电池的系统。INA190-Q1 可在独立于电源电压的  $-0.2\text{V}$  至  $+40\text{V}$  的共模电压下检测分流器上的压降。此外, 输入引脚还具有 42V 的绝对最大电压。

该器件的低输入偏置电流允许使用较大的电流检测电阻器, 从而能够提供微安级的精确电流测量。零漂移架构的低失调电压扩展了电流测量的动态范围。此功能可支持较小的感应电阻器在具有较低功率损耗的同时, 仍提供精确的电流测量。

INA190-Q1 由 1.7V 至 5.5V 的单电源供电, 在启用时消耗的最大电源电流为  $65\mu\text{A}$ 。提供五个固定增益选项: 25V/V、50V/V、100V/V、200V/V 或 500V/V。该器件的额定工作温度范围为  $-40^{\circ}\text{C}$  至  $+125^{\circ}\text{C}$ , 并采用 SC70 封装。

### 器件信息(1)

器件型号	封装	封装尺寸 (标称值)
INA190-Q1	SC70 (6)	2.00mm x 1.25mm

(1) 如需了解所有可用封装, 请参阅数据表末尾的封装选项附录。

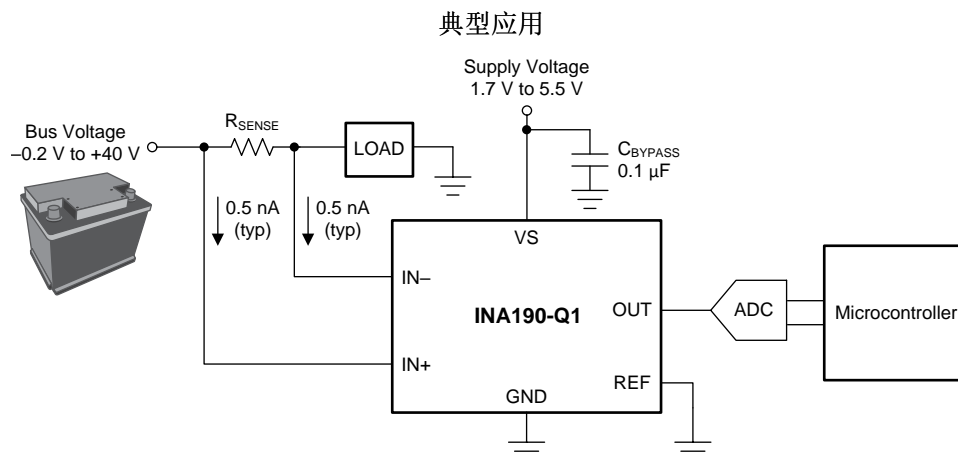

## 目录

<b>1</b>	特性 .....	1	7.4	Device Functional Modes.....	15
<b>2</b>	应用 .....	1	<b>8</b>	<b>Application and Implementation</b> .....	18
<b>3</b>	说明 .....	1	8.1	Application Information.....	18
<b>4</b>	修订历史记录 .....	2	8.2	Typical Applications .....	23
<b>5</b>	<b>Pin Configuration and Functions</b> .....	3	<b>9</b>	<b>Power Supply Recommendations</b> .....	24
<b>6</b>	<b>Specifications</b> .....	4	<b>10</b>	<b>Layout</b> .....	25
6.1	Absolute Maximum Ratings .....	4	10.1	Layout Guidelines .....	25
6.2	ESD Ratings.....	4	10.2	Layout Example .....	25
6.3	Recommended Operating Conditions.....	4	<b>11</b>	器件和文档支持 .....	26
6.4	Thermal Information .....	4	11.1	文档支持 .....	26
6.5	Electrical Characteristics.....	5	11.2	接收文档更新通知 .....	26
6.6	Typical Characteristics .....	7	11.3	社区资源.....	26
<b>7</b>	<b>Detailed Description</b> .....	12	11.4	商标.....	26
7.1	Overview .....	12	11.5	静电放电警告.....	26
7.2	Functional Block Diagram .....	12	11.6	Glossary .....	26
7.3	Feature Description.....	13	<b>12</b>	机械、封装和可订购信息 .....	26

## 4 修订历史记录

日期	修订版本	说明
2019 年 5 月	*	初始发行版。

## 5 Pin Configuration and Functions

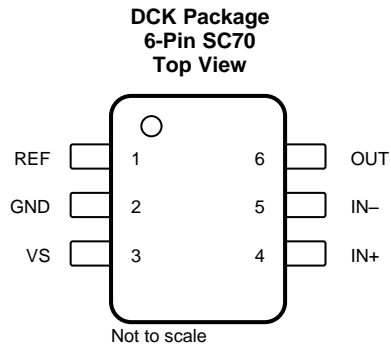

### Pin Functions

PIN		TYPE	DESCRIPTION
NAME	NO.		
GND	2	Analog	Ground
IN-	5	Analog input	Current-sense amplifier negative input. For high-side applications, connect to load side of sense resistor. For low-side applications, connect to ground side of sense resistor.
IN+	4	Analog input	Current-sense amplifier positive input. For high-side applications, connect to bus voltage side of sense resistor. For low-side applications, connect to load side of sense resistor.
OUT	6	Analog output	OUT pin. This pin provides an analog voltage output that is the gained up voltage difference from the IN+ to the IN- pins, and is offset by the voltage applied to the REF pin.
REF	1	Analog input	Reference input. Enables bidirectional current sensing with an externally applied voltage.
VS	3	Analog	Power supply, 1.7 V to 5.5 V

## 6 Specifications

### 6.1 Absolute Maximum Ratings

over operating free-air temperature range (unless otherwise noted)<sup>(1)</sup>

		MIN	MAX	UNIT
Supply voltage, $V_S$			6	V
Analog inputs, $V_{IN+}$ , $V_{IN-}$ <sup>(2)</sup>	Differential ( $V_{IN+}$ ) – ( $V_{IN-}$ )	–42	42	V
	$V_{IN+}$ , $V_{IN-}$ , with respect to GND <sup>(3)</sup>	GND – 0.3	42	
ENABLE		GND – 0.3	6	V
REF, OUT <sup>(3)</sup>		GND – 0.3	( $V_S$ ) + 0.3	V
Input current into any pin <sup>(3)</sup>			5	mA
Operating temperature, $T_A$		–55	150	°C
Junction temperature, $T_J$			150	°C
Storage temperature, $T_{stg}$		–65	150	°C

- (1) Stresses beyond those listed under *Absolute Maximum Ratings* may cause permanent damage to the device. These are stress ratings only, which do not imply functional operation of the device at these or any other conditions beyond those indicated under *Recommended Operating Conditions*. Exposure to absolute-maximum-rated conditions for extended periods may affect device reliability.
- (2)  $V_{IN+}$  and  $V_{IN-}$  are the voltages at the IN+ and IN– pins, respectively.
- (3) Input voltage at any pin may exceed the voltage shown if the current at that pin is limited to 5 mA.

### 6.2 ESD Ratings

			VALUE	UNIT
$V_{(ESD)}$	Electrostatic discharge	Human-body model (HBM), per AEC Q100-002 <sup>(1)</sup> HBM ESD Classification Level 2	±3000	V
		Charged-device model (CDM), per AEC Q100-011 CDM ESD Classification Level C6	±1000	

- (1) AEC Q100-002 indicates that HBM stressing shall be in accordance with the ANSI/ESDA/JEDEC JS-001 specification.

### 6.3 Recommended Operating Conditions

over operating free-air temperature range (unless otherwise noted)

		MIN	NOM	MAX	UNIT
$V_{CM}$	Common-mode input range	GND – 0.2		40	V
$V_{IN+}$ , $V_{IN-}$	Input pin voltage range	GND – 0.2		40	V
$V_S$	Operating supply voltage	1.7		5.5	V
$V_{REF}$	Reference pin voltage range	GND		$V_S$	V
$T_A$	Operating free-air temperature	–40		125	°C

### 6.4 Thermal Information

THERMAL METRIC <sup>(1)</sup>		INA190-Q1		UNIT
		DCK (SC70)		
		6 PINS		
$R_{qJA}$	Junction-to-ambient thermal resistance	170.7		°C/W
$R_{qJC(top)}$	Junction-to-case (top) thermal resistance	132.7		°C/W
$R_{qJB}$	Junction-to-board thermal resistance	65.3		°C/W
$Y_{JT}$	Junction-to-top characterization parameter	45.7		°C/W
$Y_{JB}$	Junction-to-board characterization parameter	65.2		°C/W
$R_{qJC(bot)}$	Junction-to-case (bottom) thermal resistance	N/A		°C/W

- (1) For more information about traditional and new thermal metrics, see the [Semiconductor and IC Package Thermal Metrics](#) application report.

## 6.5 Electrical Characteristics

at  $T_A = 25^\circ\text{C}$ ,  $V_{\text{SENSE}} = V_{\text{IN}+} - V_{\text{IN}-}$ ,  $V_S = 1.8\text{ V to } 5.0\text{ V}$ ,  $V_{\text{IN}+} = 12\text{ V}$ , and  $V_{\text{REF}} = V_S / 2$  (unless otherwise noted)

PARAMETER		CONDITIONS	MIN	TYP	MAX	UNIT
<b>INPUT</b>						
CMRR	Common-mode rejection ratio	$V_{\text{SENSE}} = 0\text{ mV}$ , $V_{\text{IN}+} = -0.1\text{ V to } 40\text{ V}$ , $T_A = -40^\circ\text{C to } +125^\circ\text{C}$	132	150		dB
$V_{\text{OS}}$	Offset voltage, RTI <sup>(1)</sup>	$V_S = 1.8\text{ V}$ , $V_{\text{SENSE}} = 0\text{ mV}$		-3	±15	µV
$dV_{\text{OS}}/dT$	Offset drift, RTI	$V_{\text{SENSE}} = 0\text{ mV}$ , $T_A = -40^\circ\text{C to } +125^\circ\text{C}$		10	80	nV/°C
PSRR	Power-supply rejection ratio, RTI	$V_{\text{SENSE}} = 0\text{ mV}$ , $V_S = 1.7\text{ V to } 5.5\text{ V}$		-1	±5	µV/V
$I_{\text{IB}}$	Input bias current	$V_{\text{SENSE}} = 0\text{ mV}$		0.5	3	nA
$I_{\text{IO}}$	Input offset current	$V_{\text{SENSE}} = 0\text{ mV}$		±0.07		nA
<b>OUTPUT</b>						
G	Gain	A1 devices		25		V/V
		A2 devices		50		
		A3 devices		100		
		A4 devices		200		
		A5 devices		500		
$E_G$	Gain error	$V_{\text{OUT}} = 0.1\text{ V to } V_S - 0.1\text{ V}$	A1 devices	-0.04%	±0.2%	
			A2, A3, A4 devices	-0.06%	±0.3%	
			A5 devices	-0.08%	±0.4%	
	Gain error drift	$T_A = -40^\circ\text{C to } +125^\circ\text{C}$		2	7	ppm/°C
	Nonlinearity error	$V_{\text{OUT}} = 0.1\text{ V to } V_S - 0.1\text{ V}$		±0.01%		
RVRR	Reference voltage rejection ratio	$V_{\text{REF}} = 100\text{ mV to } V_S - 100\text{ mV}$ , $T_A = -40^\circ\text{C to } +125^\circ\text{C}$	A1 devices	±2	±10	µV/V
			A2 devices	±1	±6	
			A3 devices	±0.5	±4	
			A4, A5 devices	±0.25	±3	
	Maximum capacitive load	No sustained oscillation		1		nF
<b>VOLTAGE OUTPUT</b>						
$V_{\text{SP}}$	Swing to $V_S$ power-supply rail	$V_S = 1.8\text{ V}$ , $R_L = 10\text{ k}\Omega$ to GND, $T_A = -40^\circ\text{C to } +125^\circ\text{C}$		$(V_S) - 20$	$(V_S) - 40$	mV
$V_{\text{SN}}$	Swing to GND	$V_S = 1.8\text{ V}$ , $R_L = 10\text{ k}\Omega$ to GND, $T_A = -40^\circ\text{C to } +125^\circ\text{C}$ , $V_{\text{SENSE}} = -10\text{ mV}$ , $V_{\text{REF}} = 0\text{ V}$		$(V_{\text{GND}}) + 0.05$	$(V_{\text{GND}}) + 1$	mV
$V_{\text{ZL}}$	Zero current output voltage	$V_S = 1.8\text{ V}$ , $R_L = 10\text{ k}\Omega$ to GND, $T_A = -40^\circ\text{C to } +125^\circ\text{C}$ , $V_{\text{SENSE}} = 0\text{ mV}$ , $V_{\text{REF}} = 0\text{ V}$	A1, A2, A3 devices	$(V_{\text{GND}}) + 1$	$(V_{\text{GND}}) + 3$	mV
			A4 devices	$(V_{\text{GND}}) + 2$	$(V_{\text{GND}}) + 4$	mV
			A5 devices	$(V_{\text{GND}}) + 3$	$(V_{\text{GND}}) + 9$	mV
<b>FREQUENCY RESPONSE</b>						
BW	Bandwidth	A1 devices, $C_{\text{LOAD}} = 10\text{ pF}$		45		kHz
		A2 devices, $C_{\text{LOAD}} = 10\text{ pF}$		37		
		A3 devices, $C_{\text{LOAD}} = 10\text{ pF}$		35		
		A4 devices, $C_{\text{LOAD}} = 10\text{ pF}$		33		
		A5 devices, $C_{\text{LOAD}} = 10\text{ pF}$		27		
SR	Slew rate	$V_S = 5.0\text{ V}$ , $V_{\text{OUT}} = 0.5\text{ V to } 4.5\text{ V}$		0.3		V/µs
$t_s$	Settling time	From current step to within 1% of final value		30		µs

(1) RTI = referred-to-input.

**Electrical Characteristics (continued)**

 at  $T_A = 25^\circ\text{C}$ ,  $V_{\text{SENSE}} = V_{\text{IN+}} - V_{\text{IN-}}$ ,  $V_S = 1.8\text{ V to } 5.0\text{ V}$ ,  $V_{\text{IN+}} = 12\text{ V}$ , and  $V_{\text{REF}} = V_S / 2$  (unless otherwise noted)

PARAMETER	CONDITIONS	MIN	TYP	MAX	UNIT
<b>NOISE, RTI<sup>(1)</sup></b>					
Voltage noise density			75		nV/ $\sqrt{\text{Hz}}$
<b>ENABLE</b>					
<b>POWER SUPPLY</b>					
$I_Q$	Quiescent current	$V_S = 1.8\text{ V}$ , $V_{\text{SENSE}} = 0\text{ mV}$	48	65	$\mu\text{A}$
		$V_S = 1.8\text{ V}$ , $V_{\text{SENSE}} = 0\text{ mV}$ , $T_A = -40^\circ\text{C to } +125^\circ\text{C}$		90	$\mu\text{A}$

### 6.6 Typical Characteristics

at  $T_A = 25^\circ\text{C}$ ,  $V_S = 1.8\text{ V}$ ,  $V_{IN+} = 12\text{ V}$ , and  $V_{REF} = V_S / 2$ , and for all gain options (unless otherwise noted)



图 1. Input Offset Voltage Production Distribution



图 2. Offset Voltage vs Temperature

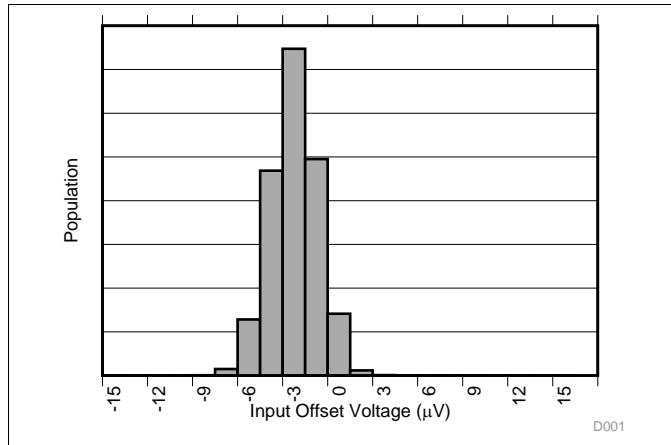

图 3. Common-Mode Rejection Production Distribution

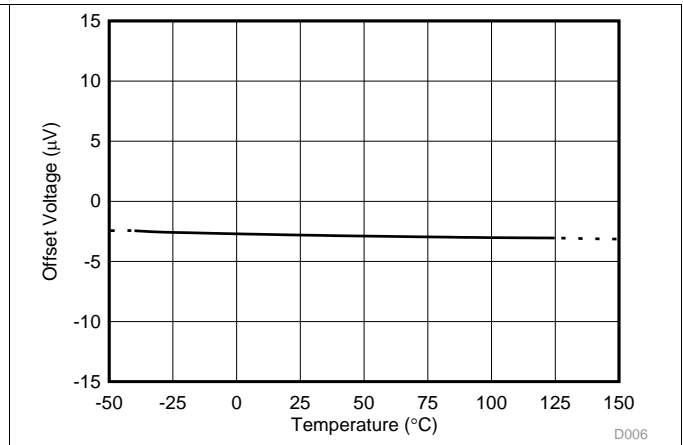

图 4. Common-Mode Rejection Ratio vs Temperature

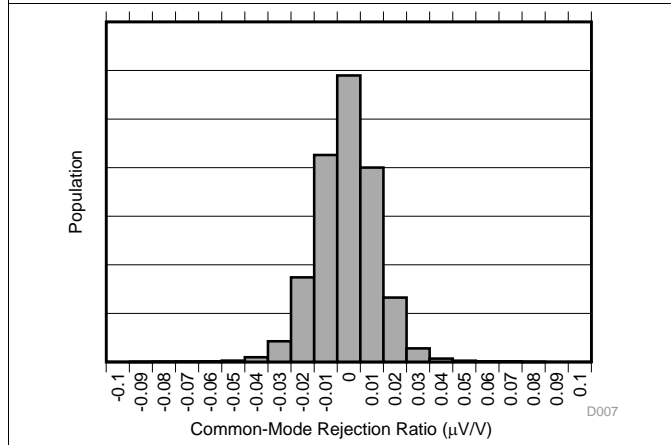

图 5. Gain Error Production Distribution

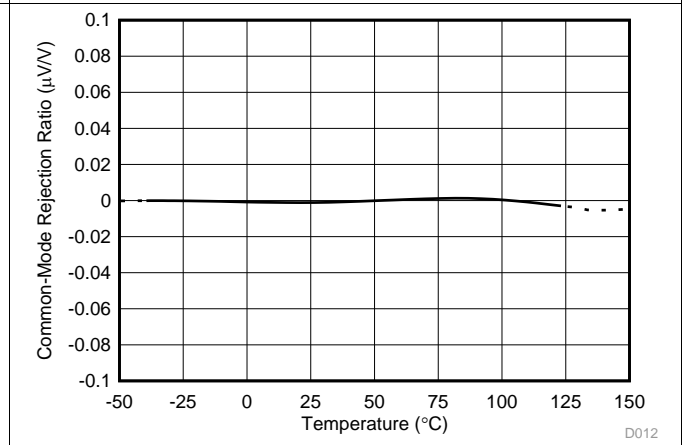

图 6. Gain Error Production Distribution

Typical Characteristics (接下页)

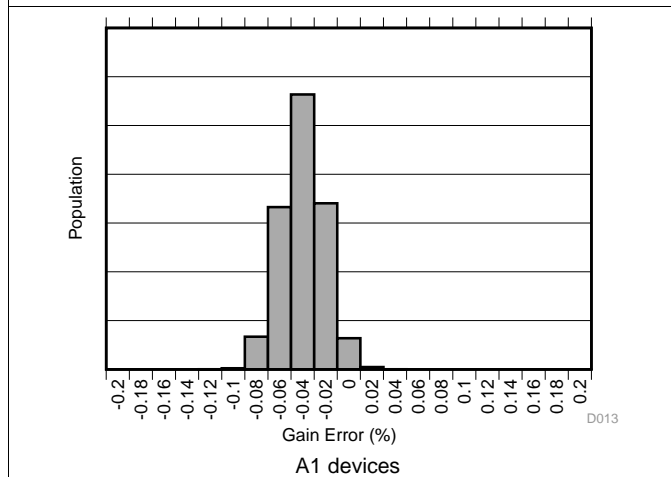
at  $T_A = 25^\circ\text{C}$ ,  $V_S = 1.8\text{ V}$ ,  $V_{IN+} = 12\text{ V}$ , and  $V_{REF} = V_S / 2$ , and for all gain options (unless otherwise noted)

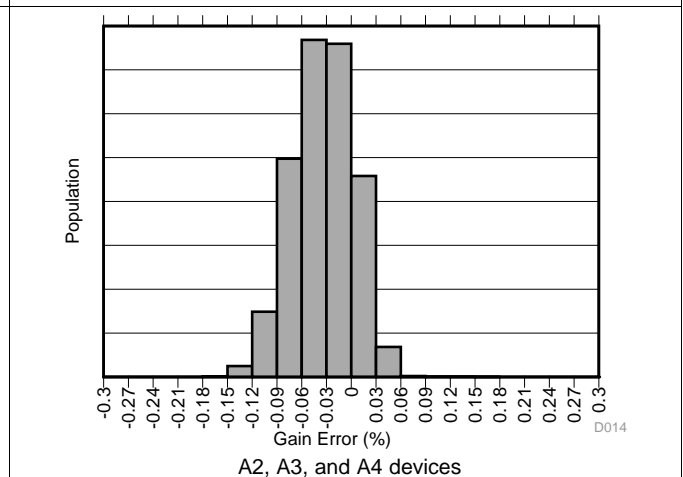
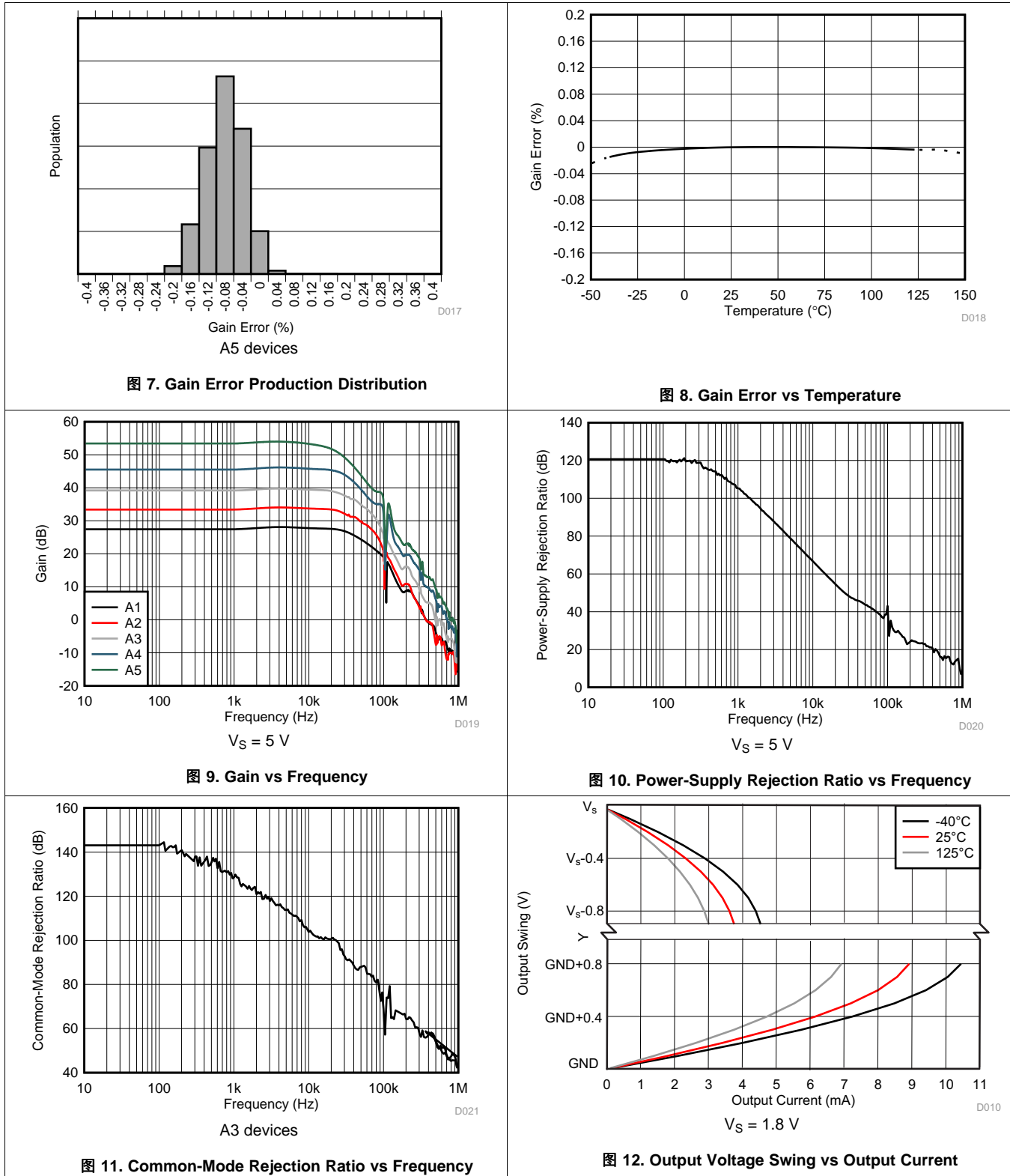

Typical Characteristics (接下页)

at  $T_A = 25^\circ\text{C}$ ,  $V_S = 1.8\text{ V}$ ,  $V_{IN+} = 12\text{ V}$ , and  $V_{REF} = V_S / 2$ , and for all gain options (unless otherwise noted)



图 13. Output Voltage Swing vs Output Current



图 14. Input Bias Current vs Common-Mode Voltage

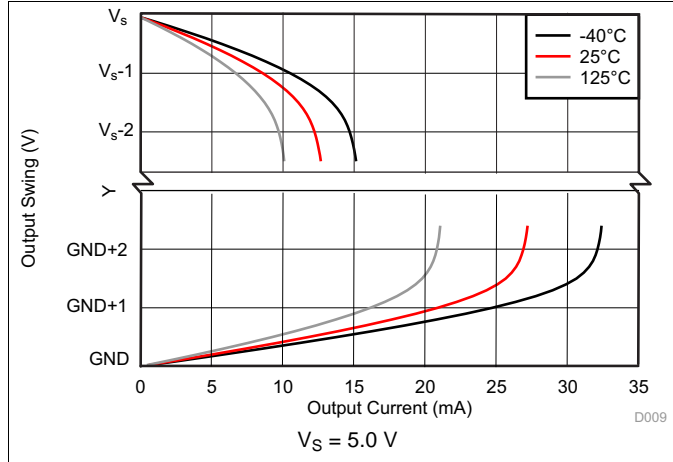

图 15. Input Bias Current vs Temperature

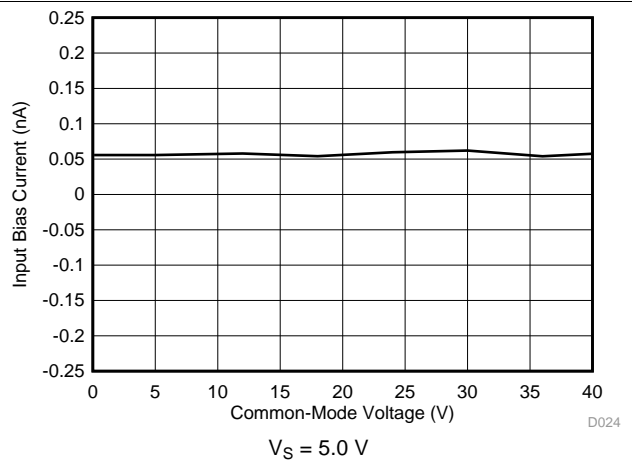

图 16. Quiescent Current vs Temperature

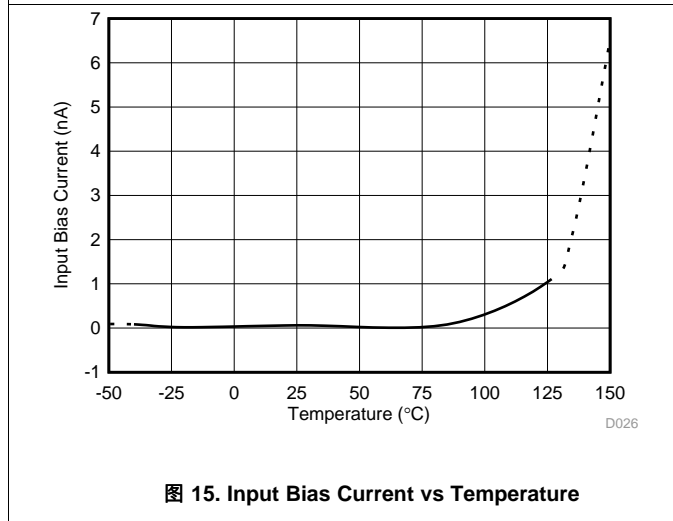

图 17. Quiescent Current vs Common Mode Voltage

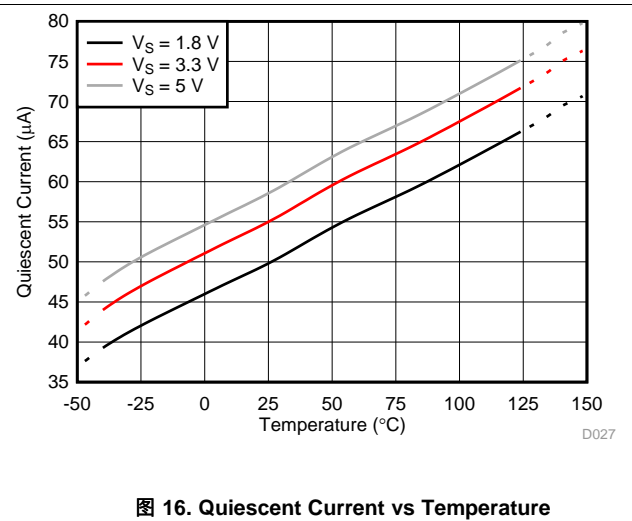

图 18. Input-Referred Voltage Noise vs Frequency

Typical Characteristics (接下页)

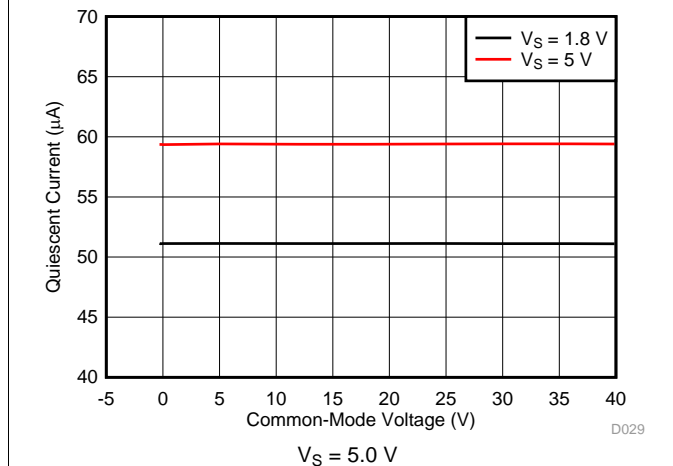
at  $T_A = 25^\circ\text{C}$ ,  $V_S = 1.8\text{ V}$ ,  $V_{IN+} = 12\text{ V}$ , and  $V_{REF} = V_S / 2$ , and for all gain options (unless otherwise noted)

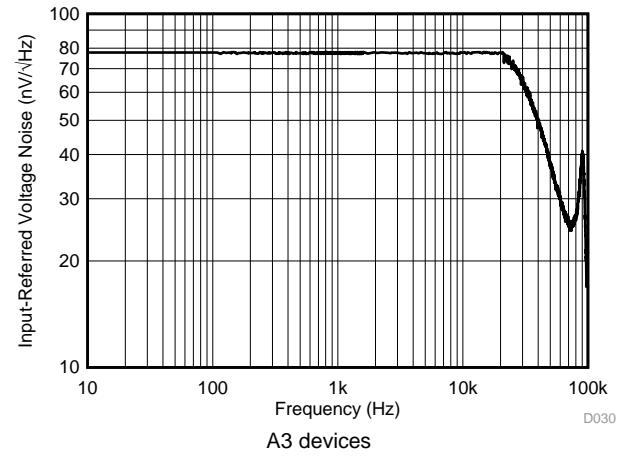
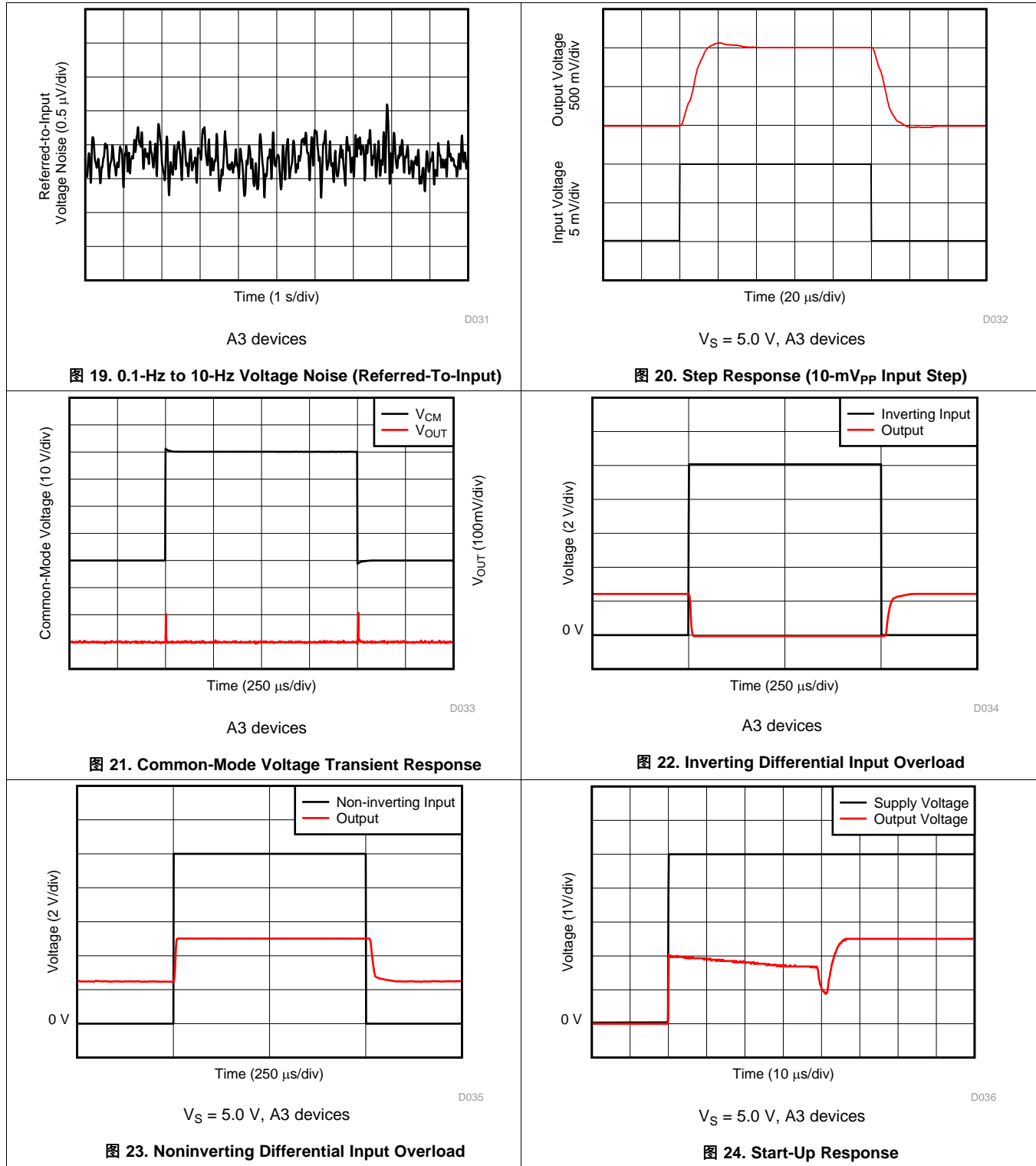

Typical Characteristics (接下页)

at  $T_A = 25^\circ\text{C}$ ,  $V_S = 1.8\text{ V}$ ,  $V_{IN+} = 12\text{ V}$ , and  $V_{REF} = V_S / 2$ , and for all gain options (unless otherwise noted)



图 25. Brownout Recovery



图 26.  $IB+$  and  $IB-$  vs Differential Input Voltage

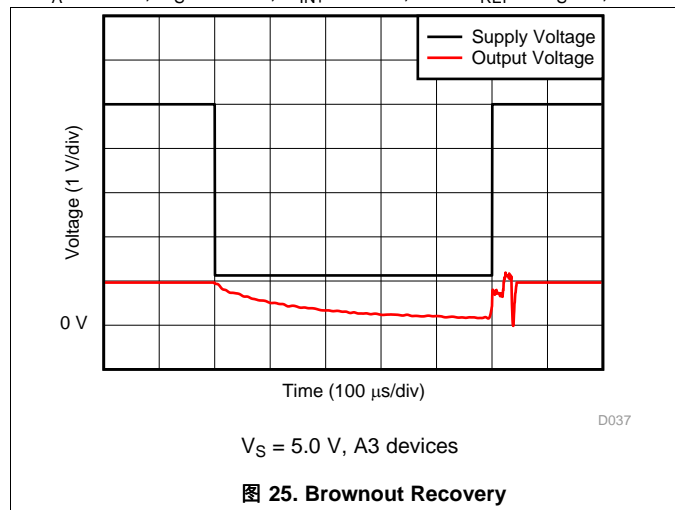

图 27.  $IB+$  and  $IB-$  vs Differential Input Voltage

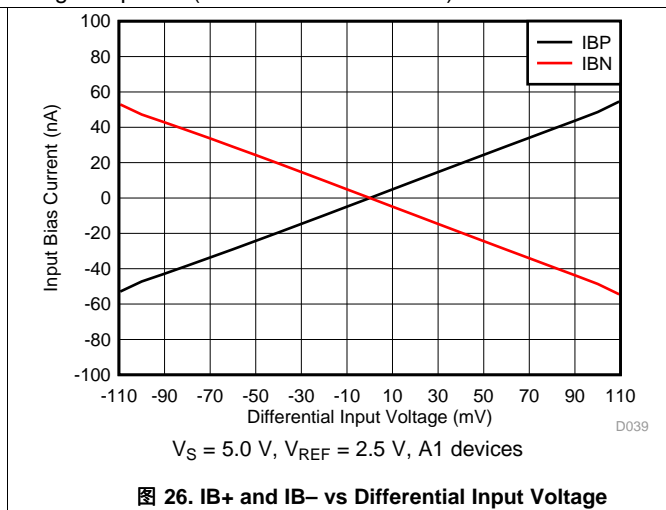

图 28. Output Impedance vs Frequency

## 7 Detailed Description

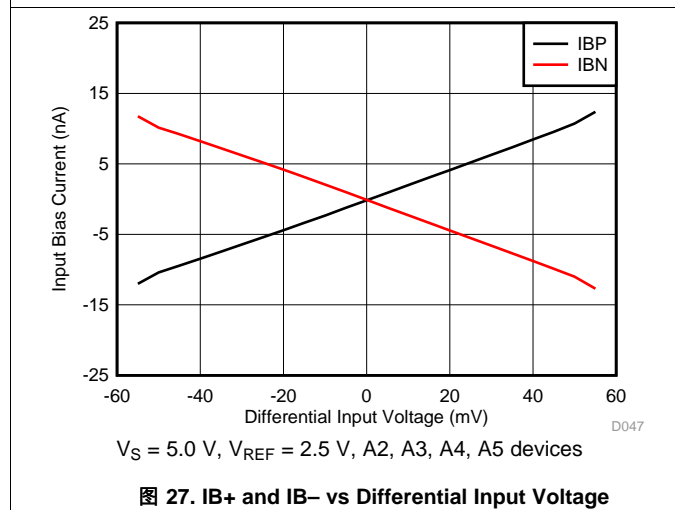
### 7.1 Overview

The INA190-Q1 is a low bias current, low offset, 40-V common-mode, current-sensing amplifier. The INA190-Q1 is a specially designed, current-sensing amplifier that accurately measures voltages developed across current-sensing resistors on common-mode voltages that far exceed the supply voltage. Current is measured on input voltage rails as high as 40 V at  $V_{IN+}$  and  $V_{IN-}$ , with a supply voltage,  $V_S$ , as low as 1.7 V. The INA190-Q1 is intended for use in both low-side and high-side current-sensing configurations where high accuracy and low current consumption are required.

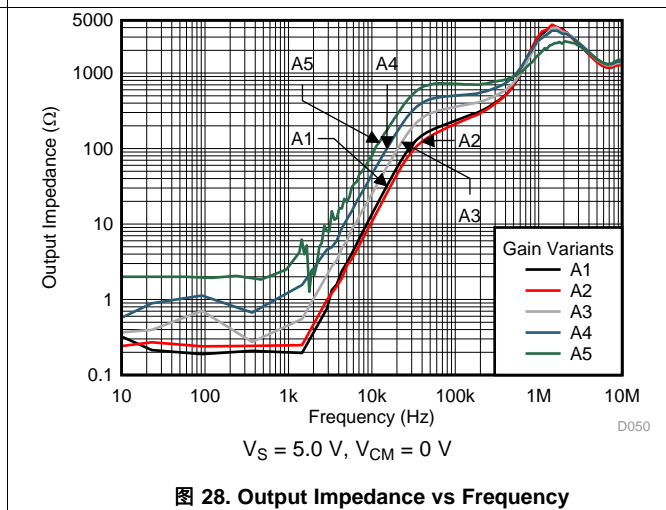
### 7.2 Functional Block Diagram

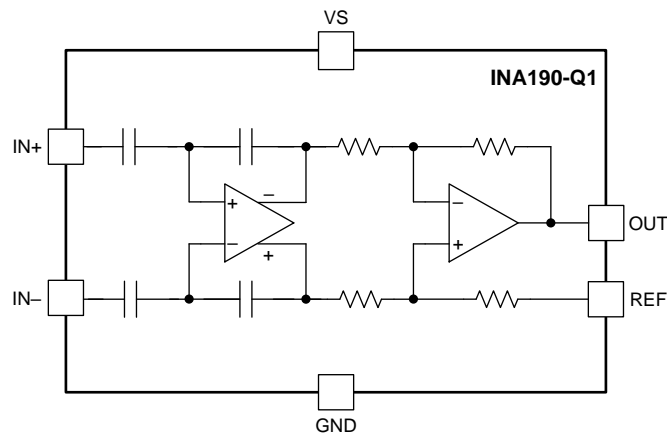

## 7.3 Feature Description

### 7.3.1 Precision Current Measurement

The INA190-Q1 allows for accurate current measurements over a wide dynamic range. The high accuracy of the device is attributable to the low gain error and offset specifications. The offset voltage of the INA190-Q1 is less than 15  $\mu\text{V}$ . In this case, the low offset improves the accuracy at light loads when  $V_{\text{IN}+}$  approaches  $V_{\text{IN}-}$ . Another advantage of low offset is the ability to use a lower-value shunt resistor that reduces the power loss in the current-sense circuit, and improves the power efficiency of the end application.

The maximum gain error of the INA190-Q1 is specified between 0.2% and 0.4% of the actual value, depending on the gain option. As the sensed voltage becomes much larger than the offset voltage, the gain error becomes the dominant source of error in the current-sense measurement. When the device monitors currents near the full-scale output range, the total measurement error approaches the value of the gain error.

### 7.3.2 Low Input Bias Current

The INA190-Q1 is different from many current-sense amplifiers because this device offers very low input bias current. The low input bias current of the INA190-Q1 has three primary benefits.

The first benefit is the reduction of the current consumed by the device. Classical current-sense amplifier topologies typically consume tens of microamps of current at the inputs. For these amplifiers, the input current is the result of the resistor network that sets the gain and additional current to bias the input amplifier. To reduce the bias current to near zero, the INA190-Q1 uses a capacitively coupled amplifier on the input stage, followed by a difference amplifier on the output stage.

The second benefit of low bias current is the ability to use input filters to reject high-frequency noise before the signal is amplified. In a traditional current-sense amplifier, the addition of input filters comes at the cost of reduced accuracy. However, as a result of the low bias currents, input filters have little effect on the measurement accuracy of the INA190-Q1.

The third benefit of low bias current is the ability to use a larger current-sense resistor. This ability allows the device to accurately monitor currents as low as 1  $\mu\text{A}$ .

### 7.3.3 Low Quiescent Current

The device features low quiescent current ( $I_{\text{Q}}$ ), while still providing sufficient small-signal bandwidth to be usable in most applications. The quiescent current of the INA190-Q1 is only 48  $\mu\text{A}$  (typ), while providing a small-signal bandwidth of 35 kHz in a gain of 100. The low  $I_{\text{Q}}$  and good bandwidth allow the device to be used in many portable electronic systems without excessive drain on the battery.

### 7.3.4 Bidirectional Current Monitoring

INA190-Q1 devices can sense current flow through a sense resistor in both directions. The bidirectional current-sensing capability is achieved by applying a voltage at the REF pin to offset the output voltage. A positive differential voltage sensed at the inputs results in an output voltage that is greater than the applied reference voltage. Likewise, a negative differential voltage at the inputs results in output voltage that is less than the applied reference voltage. The output voltage of the current-sense amplifier is shown in [公式 1](#).

$$V_{\text{OUT}} = (I_{\text{LOAD}} \times R_{\text{SENSE}} \times \text{GAIN}) + V_{\text{REF}}$$

where

- $I_{\text{LOAD}}$  is the load current to be monitored.
- $R_{\text{SENSE}}$  is the current-sense resistor.
- GAIN is the gain option of the selected device.
- $V_{\text{REF}}$  is the voltage applied to the REF pin.

(1)

## Feature Description (接下页)

### 7.3.5 High-Side and Low-Side Current Sensing

The INA190-Q1 supports input common-mode voltages from  $-0.2\text{ V}$  to  $+40\text{ V}$ . Because of the internal topology, the common-mode range is not restricted by the power-supply voltage ( $V_S$ ). The ability to operate with common-mode voltages greater or less than  $V_S$  allows the INA190-Q1 to be used in high-side and low-side current-sensing applications, as shown in 图 29.



图 29. High-Side and Low-Side Sensing Connections

### 7.3.6 High Common-Mode Rejection

The INA190-Q1 uses a capacitively coupled amplifier on the front end. Therefore, dc common-mode voltages are blocked from downstream circuits, resulting in very high common-mode rejection. Typically, the common-mode rejection of the INA190-Q1 is approximately 150 dB. The ability to reject changes in the dc common-mode voltage allows the INA190-Q1 to monitor both high- and low-voltage rail currents with very little change in the offset voltage.

### 7.3.7 Rail-to-Rail Output Swing

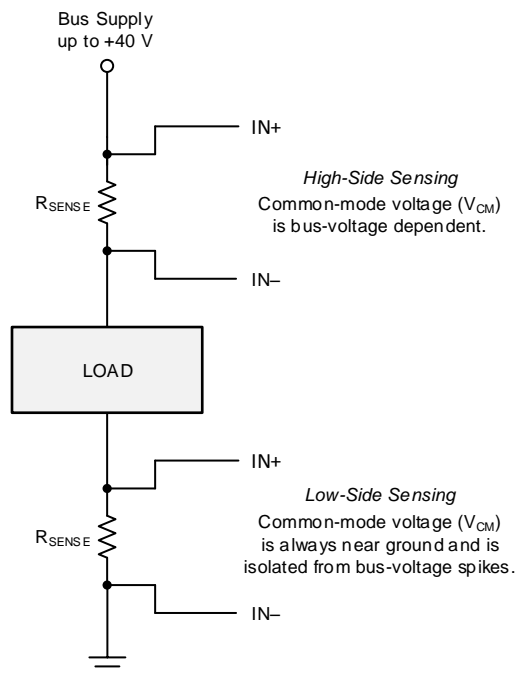
The INA190-Q1 allows linear current-sensing operation with the output close to the supply rail and ground. The maximum specified output swing to the positive rail is  $V_S - 40\text{ mV}$ , and the maximum specified output swing to GND is only  $\text{GND} + 1\text{ mV}$ . The close-to-rail output swing is useful to maximize the usable output range, particularly when operating the device from a 1.8-V supply.

## 7.4 Device Functional Modes

### 7.4.1 Normal Operation

The INA190-Q1 is in normal operation when the following conditions are met:

- The power-supply voltage ( $V_S$ ) is between 1.7 V and 5.5 V.
- The common-mode voltage ( $V_{CM}$ ) is within the specified range of  $-0.2$  V to  $+40$  V.
- The maximum differential input signal times the gain plus  $V_{REF}$  is less than the positive swing voltage  $V_{SP}$ .
- The minimum differential input signal times the gain plus  $V_{REF}$  is greater than the zero load swing to GND,  $V_{ZL}$  (see the [Rail-to-Rail Output Swing](#) section).

During normal operation, this device produces an output voltage that is the *amplified* representation of the difference voltage from  $IN+$  to  $IN-$  plus the voltage applied to the REF pin.

### 7.4.2 Unidirectional Mode

This device can be configured to monitor current flowing in one direction (unidirectional) or in both directions (bidirectional) depending on how the REF pin is connected. The most common case is unidirectional where the output is set to ground when no current is flowing by connecting the REF pin to ground, as shown in [图 30](#). When the current flows from the bus supply to the load, the input voltage from  $IN+$  to  $IN-$  increases and causes the output voltage at the OUT pin to increase.



图 30. Typical Unidirectional Application

The linear range of the output stage is limited by how close the output voltage can approach ground under zero input conditions. The zero current output voltage of the INA190-Q1 is very small and for most unidirectional applications the REF pin is simply grounded. However, if the measured current multiplied by the current sense resistor and device gain is less than the zero current output voltage then bias the REF pin to a convenient value above the zero current output voltage to get the output into the linear range of the device. To limit common-mode rejection errors, buffer the reference voltage connected to the REF pin.

A less-frequently used output biasing method is to connect the REF pin to the power-supply voltage,  $V_S$ . This method results in the output voltage saturating at 40 mV less than the supply voltage when no differential input voltage is present. This method is similar to the output saturated low condition with no differential input voltage when the REF pin is connected to ground. The output voltage in this configuration only responds to currents that develop negative differential input voltage relative to the device  $IN-$  pin. Under these conditions, when the negative differential input signal increases, the output voltage moves downward from the saturated supply voltage. The voltage applied to the REF pin must not exceed  $V_S$ .

## Device Functional Modes (接下页)

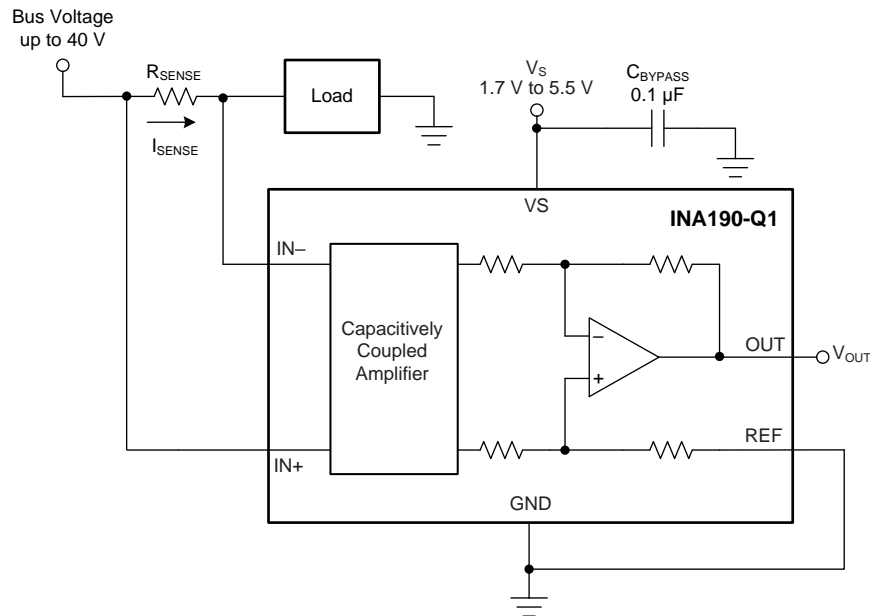
Another use for the REF pin in unidirectional operation is to level shift the output voltage. 图 31 shows an application where the device ground is set to a negative voltage so currents biased to negative supplies, as seen in optical networking cards, can be measured. The GND of the INA190-Q1 can be set to negative voltages, as long as the inputs do not violate the common-mode range specification and the voltage difference between VS and GND does not exceed 5.5 V. In this example, the output of the INA190-Q1 is fed into a positive-biased ADC. By grounding the REF pin, the voltages at the output will be positive and not damage the ADC. To make sure the output voltage never goes negative, the supply sequencing must be the positive supply first, followed by the negative supply.



图 31. Using the REF Pin to Level-Shift Output Voltage

## Device Functional Modes (接下页)

### 7.4.3 Bidirectional Mode

The INA190-Q1 devices are bidirectional current-sense amplifiers capable of measuring currents through a resistive shunt in two directions. This bidirectional monitoring is common in applications that include charging and discharging operations where the current flowing through the resistor can change directions.

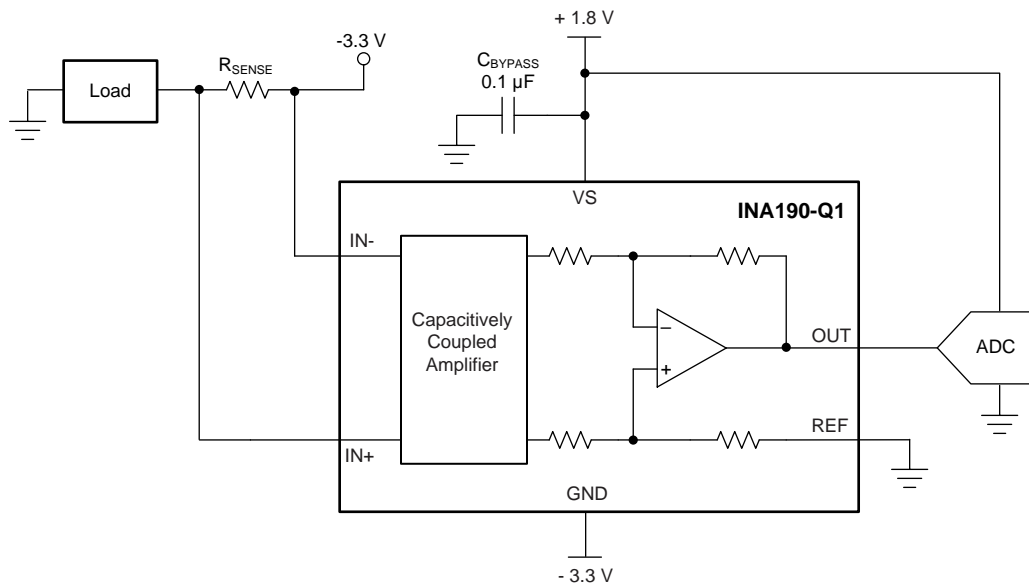

图 32. Bidirectional Application

The ability to measure this current flowing in both directions is achieved by applying a voltage to the REF pin, as shown in 图 32. The voltage applied to REF ( $V_{REF}$ ) sets the output state that corresponds to the zero-input level state. The output then responds by increasing above  $V_{REF}$  for positive differential signals (relative to the IN- pin) and responds by decreasing below  $V_{REF}$  for negative differential signals. This reference voltage applied to the REF pin can be set anywhere between 0 V to  $V_S$ . For bidirectional applications,  $V_{REF}$  is typically set at  $V_S/2$  for equal signal range in both current directions. In some cases,  $V_{REF}$  is set at a voltage other than  $V_S/2$ ; for example, when the bidirectional current and corresponding output signal do not need to be symmetrical.

### 7.4.4 Input Differential Overload

If the differential input voltage ( $V_{IN+} - V_{IN-}$ ) times gain exceeds the voltage swing specification, the INA190-Q1 drives its output as close as possible to the positive supply or ground, and does not provide accurate measurement of the differential input voltage. If this input overload occurs during normal circuit operation, then reduce the value of the shunt resistor or use a lower-gain version with the chosen sense resistor to avoid this mode of operation. If a differential overload occurs in a time-limited fault event, then the output of the INA190-Q1 returns to the expected value approximately 80  $\mu$ s after the fault condition is removed.

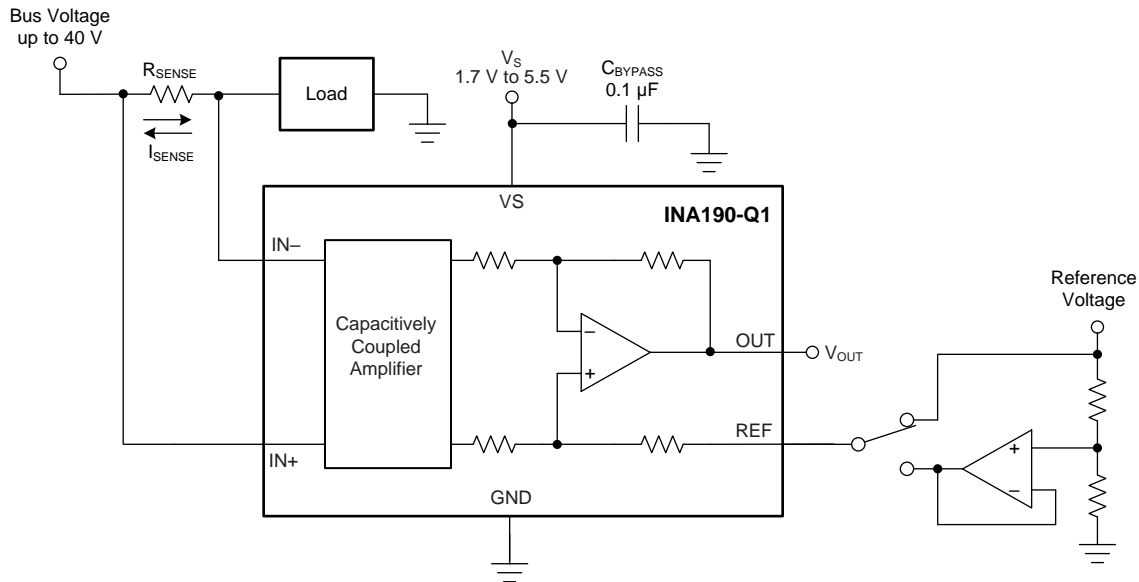
## 8 Application and Implementation

### 注

Information in the following applications sections is not part of the TI component specification, and TI does not warrant its accuracy or completeness. TI's customers are responsible for determining suitability of components for their purposes. Customers should validate and test their design implementation to confirm system functionality.

### 8.1 Application Information

The INA190-Q1 amplifies the voltage developed across a current-sensing resistor as current flows through the resistor to the load or ground. The high common-mode rejection of the INA190-Q1 make it usable over a wide range of voltage rails while still maintaining an accurate current measurement.

#### 8.1.1 Basic Connections

图 33 shows the basic connections of the INA190-Q1. Place the device as close as possible to the current sense resistor and connect the input pins (IN+ and IN-) to the current sense resistor through kelvin connections.

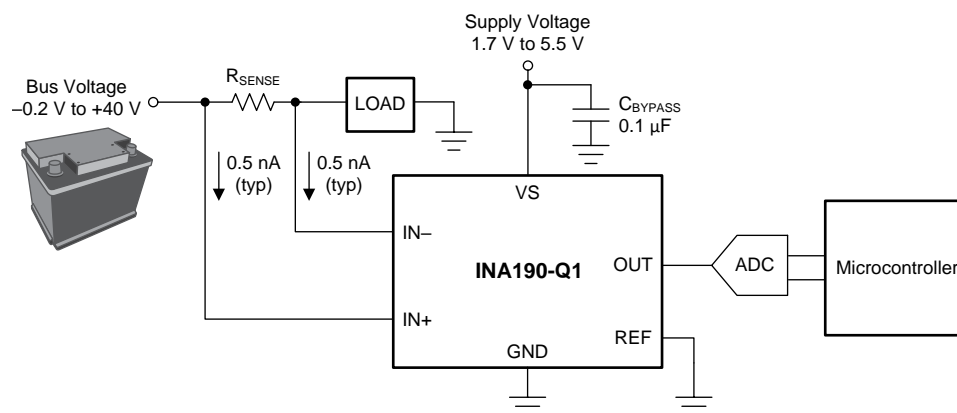

NOTE: To help eliminate ground offset errors between the device and the analog-to-digital converter (ADC), connect the REF pin to the ADC reference input. When driving SAR ADCs, filter or buffer the output of the INA190-Q1 before connecting directly to the ADC.

图 33. Basic Connections for the INA190-Q1

## Application Information (接下页)

### 8.1.2 R<sub>SENSE</sub> and Device Gain Selection

The accuracy of any current-sense amplifier is maximized by choosing the current-sense resistor to be as large as possible. A large sense resistor maximizes the differential input signal for a given amount of current flow and reduces the error contribution of the offset voltage. However, there are practical limits as to how large the current-sense resistor can be in a given application because of the resistor size and maximum allowable power dissipation. 公式 2 gives the maximum value for the current-sense resistor for a given power dissipation budget:

$$R_{\text{SENSE}} < \frac{PD_{\text{MAX}}}{I_{\text{MAX}}^2}$$

where:

- PD<sub>MAX</sub> is the maximum allowable power dissipation in R<sub>SENSE</sub>.
- I<sub>MAX</sub> is the maximum current that will flow through R<sub>SENSE</sub>. (2)

An additional limitation on the size of the current-sense resistor and device gain is due to the power-supply voltage, V<sub>S</sub>, and device swing-to-rail limitations. In order to make sure that the current-sense signal is properly passed to the output, both positive and negative output swing limitations must be examined. 公式 3 provides the maximum values of R<sub>SENSE</sub> and GAIN to keep the device from exceeding the positive swing limitation.

$$I_{\text{MAX}} \times R_{\text{SENSE}} \times \text{GAIN} < V_{\text{SP}} - V_{\text{REF}}$$

where:

- I<sub>MAX</sub> is the maximum current that will flow through R<sub>SENSE</sub>.
- GAIN is the gain of the current-sense amplifier.
- V<sub>SP</sub> is the positive output swing as specified in the data sheet.
- V<sub>REF</sub> is the externally applied voltage on the REF pin. (3)

To avoid positive output swing limitations when selecting the value of R<sub>SENSE</sub>, there is always a trade-off between the value of the sense resistor and the gain of the device under consideration. If the sense resistor selected for the maximum power dissipation is too large, then it is possible to select a lower-gain device in order to avoid positive swing limitations.

The negative swing limitation places a limit on how small the sense resistor value can be for a given application. 公式 4 provides the limit on the minimum value of the sense resistor.

$$I_{\text{MIN}} \times R_{\text{SENSE}} \times \text{GAIN} > V_{\text{SN}} - V_{\text{REF}}$$

where:

- I<sub>MIN</sub> is the minimum current that will flow through R<sub>SENSE</sub>.
- GAIN is the gain of the current-sense amplifier.
- V<sub>SN</sub> is the negative output swing of the device (see [Rail-to-Rail Output Swing](#)).
- V<sub>REF</sub> is the externally applied voltage on the REF pin. (4)

In addition to adjusting R<sub>SENSE</sub> and the device gain, the voltage applied to the REF pin can be slightly increased above GND to avoid negative swing limitations.

## Application Information (接下页)

### 8.1.3 Signal Conditioning

When performing accurate current measurements in noisy environments, the current-sensing signal is often filtered. The INA190-Q1 features low input bias currents. Therefore, adding a differential mode filter to the input without sacrificing the current-sense accuracy is possible. Filtering at the input is advantageous because this action attenuates differential noise before the signal is amplified. 图 34 provides an example of how to use a filter on the input pins of the device.



图 34. Filter at the Input Pins

The differential input impedance (R<sub>DIFF</sub>) shown in 图 34 limits the maximum value for R<sub>F</sub>. The value of R<sub>DIFF</sub> is a function of the device temperature, as shown in 图 35.

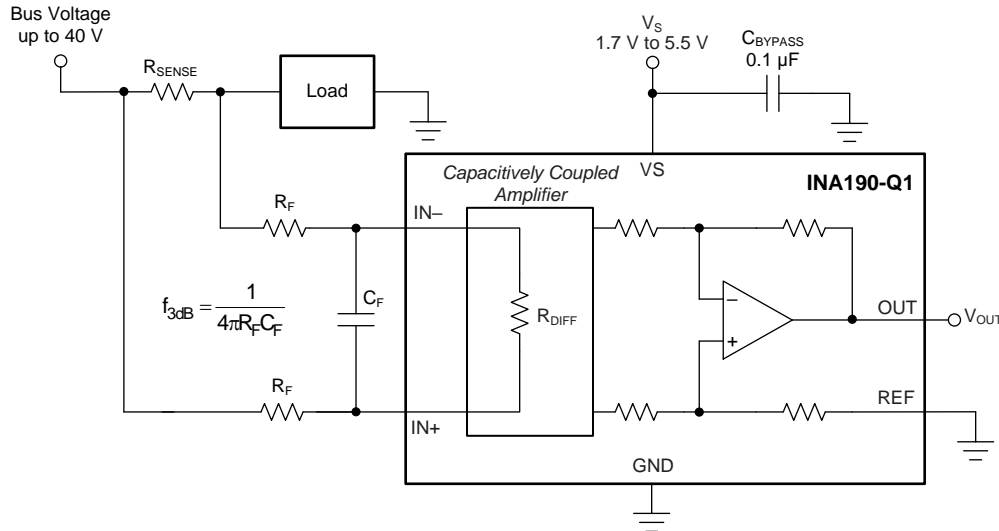

图 35. Differential Input Impedance vs Temperature

## Application Information (接下页)

As the voltage drop across the sense resistor ( $V_{\text{SENSE}}$ ) increases, the amount of voltage dropped across the input filter resistors ( $R_F$ ) also increases. The increased voltage drop results in additional gain error. The error caused by these resistors is calculated by the resistor divider equation shown in [公式 5](#).

$$\text{Error}(\%) = \left( 1 - \frac{R_{\text{DIFF}}}{R_{\text{SENSE}} + R_{\text{DIFF}} + (2 \times R_F)} \right) \times 100$$

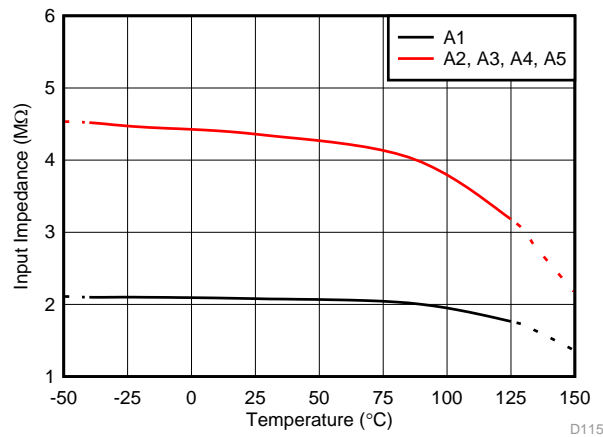
where:

- $R_{\text{DIFF}}$  is the differential input impedance.
- $R_F$  is the added value of the series filter resistance. (5)

The input stage of the INA190-Q1 uses a capacitive feedback amplifier topology in order to achieve high dc precision. As a result, periodic high-frequency shunt voltage (or current) transients of significant amplitude (10 mV or greater) and duration (hundreds of nanoseconds or greater) may be amplified by the INA190-Q1, even though the transients are greater than the device bandwidth. Use a differential input filter in these applications to minimize disturbances at the INA190-Q1 output.

The high input impedance and low bias current of the INA190-Q1 provide flexibility in the input filter design without impacting the accuracy of current measurement. For example, set  $R_F = 100 \Omega$  and  $C_F = 22 \text{ nF}$  to achieve a low-pass filter corner frequency of 36.2 kHz. These filter values significantly attenuate most unwanted high-frequency signals at the input without severely impacting the current sensing bandwidth or precision. If a lower corner frequency is desired, increase the value of  $C_F$ .

Filtering the input filters out differential noise across the sense resistor. If high-frequency, common-mode noise is a concern, add an RC filter from the OUT pin to ground. The RC filter helps filter out both differential and common mode noise, as well as, internally generated noise from the device. The value for the resistance of the RC filter is limited by the impedance of the load. Any current drawn by the load manifests as an external voltage drop from the INA190-Q1 OUT pin to the load input. To select the optimal values for the output filter, use [图 28](#) and see the [Closed-Loop Analysis of Load-Induced Amplifier Stability Issues Using ZOUT](#) application report

## Application Information (接下页)

### 8.1.4 Common-Mode Voltage Transients

With a small amount of additional circuitry, the INA190-Q1 can be used in circuits subject to transients that exceed the absolute maximum voltage ratings. The most simple way to protect the inputs from negative transients is to add resistors in series to the IN<sup>-</sup> and IN<sup>+</sup> pins. Use resistors that are 1 kΩ or less, and limit the current in the ESD structures to less than 5 mA. For example, using 1-kΩ resistors in series with the INA190-Q1 allows voltages as low as -5 V, while limiting the ESD current to less than 5 mA. If protection from high-voltage or more-negative, common-voltage transients is needed, use the circuits shown in 图 36 and 图 37. When implementing these circuits, use only Zener diodes or Zener-type transient absorbers (sometimes referred to as *transzorb*s); any other type of transient absorber has an unacceptable time delay. Start by adding a pair of resistors as a working impedance for the Zener diode, as shown in 图 36. Keep these resistors as small as possible; most often, use around 100 Ω. Larger values can be used with an effect on gain that is discussed in the [Signal Conditioning](#) section. This circuit limits only short-term transients; therefore, many applications are satisfied with a 100-Ω resistor along with conventional Zener diodes of the lowest acceptable power rating. This combination uses the least amount of board space. These diodes can be found in packages as small as SOT-523 or SOD-523.



图 36. Transient Protection Using Dual Zener Diodes

In the event that low-power Zener diodes do not have sufficient transient absorption capability, a higher-power transzorb must be used. The most package-efficient solution involves using a single transzorb and back-to-back diodes between the device inputs, as shown in 图 37. The most space-efficient solutions are dual, series-connected diodes in a single SOT-523 or SOD-523 package. In either of the examples shown in 图 36 and 图 37, the total board area required by the INA190-Q1 with all protective components is less than that of an SO-8 package, and only slightly greater than that of an VSSOP-8 package.

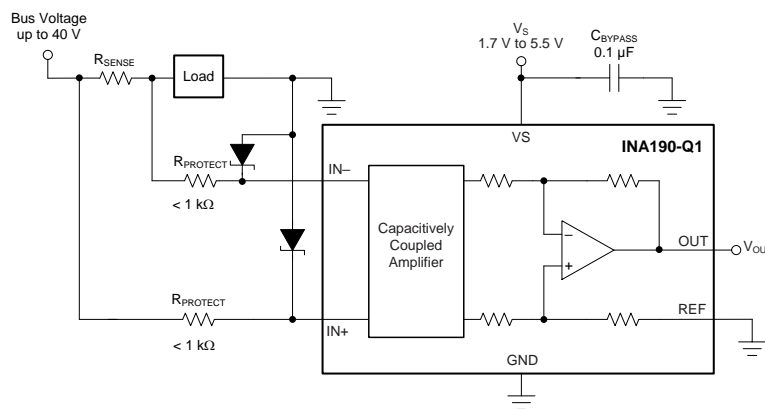

图 37. Transient Protection Using a Single Transzorb and Input Clamps

For more information, see the [Current Shunt Monitor With Transient Robustness reference design](#).

## 8.2 Typical Applications

The low input bias current of the INA190-Q1 allows accurate monitoring of small-value currents. To accurately monitor currents in the microamp range, increase the value of the sense resistor to increase the sense voltage so that the error introduced by the offset voltage is small. The circuit configuration for monitoring low-value currents is shown in [图 38](#). As a result of the differential input impedance of the INA190-Q1, limit the value of  $R_{SENSE}$  to 1 k $\Omega$  or less for best accuracy.

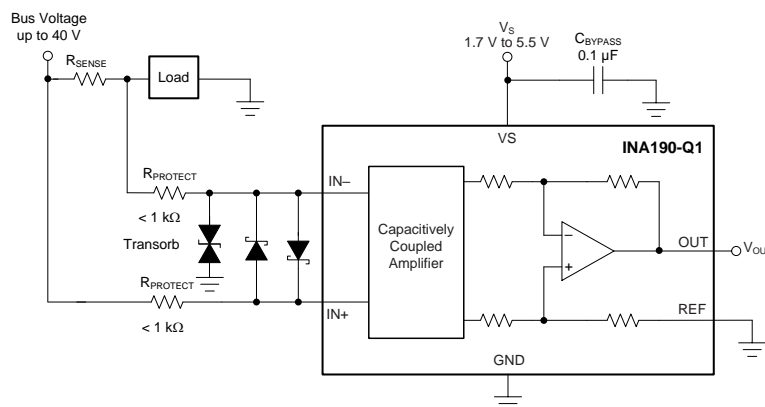

图 38. Microamp Current Measurement

### 8.2.1 Design Requirements

The design requirements for the circuit shown in [图 38](#) are listed in [表 1](#).

表 1. Design Parameters

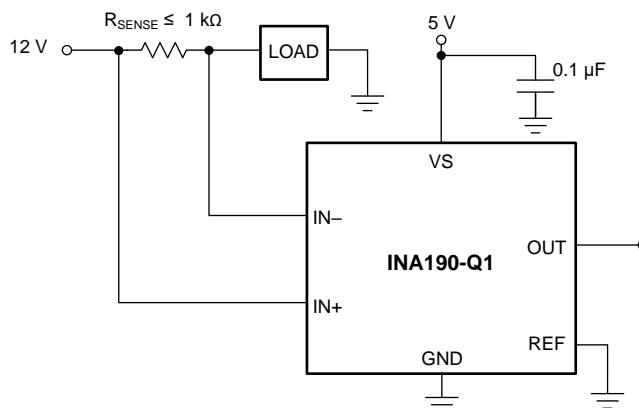
DESIGN PARAMETER	EXAMPLE VALUE
Power-supply voltage ( $V_S$ )	5 V
Bus supply rail ( $V_{CM}$ )	12 V
Minimum sense current ( $I_{MIN}$ )	1 $\mu$ A
Maximum sense current ( $I_{MAX}$ )	150 $\mu$ A
Device gain (GAIN)	25 V/V
Reference voltage ( $V_{REF}$ )	0 V

## 8.2.2 Detailed Design Procedure

The maximum value of the current-sense resistor is calculated based choice of gain, value of the maximum current the be sensed ( $I_{MAX}$ ), and the power supply voltage ( $V_S$ ). When operating at the maximum current, the output voltage must not exceed the positive output swing specification,  $V_{SP}$ . Using 公式 6, for the given design parameters the maximum value for  $R_{SENSE}$  is calculated to be 1.321 k $\Omega$ .

$$R_{SENSE} < \frac{V_{SP}}{I_{MAX} \times GAIN} \quad (6)$$

However, because this value exceeds the maximum recommended value for  $R_{SENSE}$ , a resistance value of 1 k $\Omega$  must be used. When operating at the minimum current value,  $I_{MIN}$  the output voltage must be greater than the swing to GND ( $V_{SN}$ ), specification. For this example, the output voltage at the minimum current is calculated using 公式 7 to be 25 mV, which is greater than the value for  $V_{SN}$ .

$$V_{OUTMIN} = I_{MIN} \times R_{SENSE} \times GAIN \quad (7)$$

## 8.2.3 Application Curve

图 39 shows the output of the device under the conditions given in 表 1 and with  $R_{SENSE} = 1$  k $\Omega$ .



图 39. Typical Application DC Transfer Function

## 9 Power Supply Recommendations

The input circuitry of the INA190-Q1 accurately measures beyond the power-supply voltage,  $V_S$ . For example,  $V_S$  can be 5 V, whereas the bus supply voltage at IN+ and IN– can be as high as 40 V. However, the output voltage range of the OUT pin is limited by the voltage on the VS pin. The INA190-Q1 also withstands the full differential input signal range up to 40 V at the IN+ and IN– input pins, regardless of whether the device has power applied at the VS pin. There is no sequencing requirement for  $V_S$  and  $V_{IN+}$  or  $V_{IN-}$ .

## 10 Layout

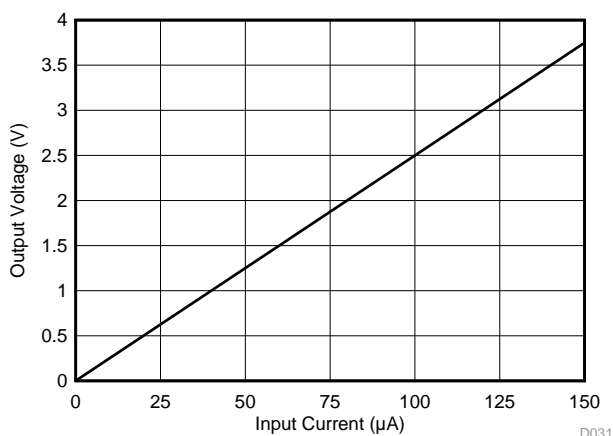
### 10.1 Layout Guidelines

- Connect the input pins to the sensing resistor using a Kelvin or 4-wire connection. This connection technique makes sure that only the current-sensing resistor impedance is detected between the input pins. Poor routing of the current-sensing resistor commonly results in additional resistance present between the input pins. Given the very low ohmic value of the current resistor, any additional high-current carrying impedance can cause significant measurement errors.
- Place the power-supply bypass capacitor as close as possible to the device power supply and ground pins. The recommended value of this bypass capacitor is 0.1  $\mu\text{F}$ . Additional decoupling capacitance can be added to compensate for noisy or high-impedance power supplies.
- When routing the connections from the current-sense resistor to the device, keep the trace lengths as short as possible. The input filter capacitor  $C_F$  should be placed as close as possible to the input pins of the device.

### 10.2 Layout Example



图 40. Recommended Layout for SC70 (DCK) Package

## 11 器件和文档支持

### 11.1 文档支持

#### 11.1.1 相关文档

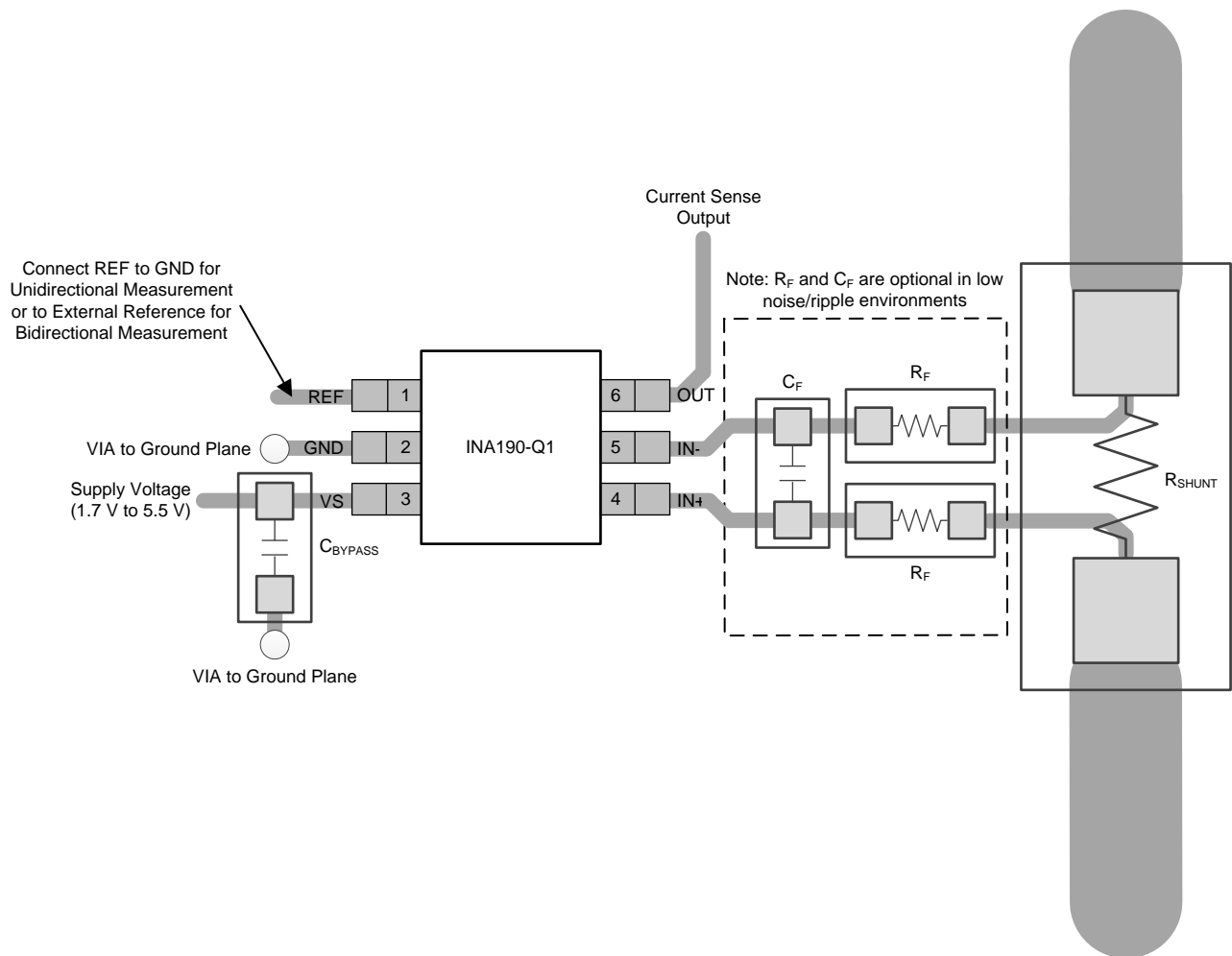
请参阅如下相关文档：：德州仪器 (TI)，《[INA190EVM 用户指南](#)》

### 11.2 接收文档更新通知

要接收文档更新通知，请导航至 [TI.com.cn](http://TI.com.cn) 上的器件产品文件夹。单击右上角的 [通知我](#) 进行注册，即可每周接收产品信息更改摘要。有关更改的详细信息，请查看任何已修订文档中包含的修订历史记录。

### 11.3 社区资源

The following links connect to TI community resources. Linked contents are provided "AS IS" by the respective contributors. They do not constitute TI specifications and do not necessarily reflect TI's views; see TI's [Terms of Use](#).

**TI E2E™ Online Community** *TI's Engineer-to-Engineer (E2E) Community*. Created to foster collaboration among engineers. At [e2e.ti.com](http://e2e.ti.com), you can ask questions, share knowledge, explore ideas and help solve problems with fellow engineers.

**Design Support** *TI's Design Support* Quickly find helpful E2E forums along with design support tools and contact information for technical support.

### 11.4 商标

E2E is a trademark of Texas Instruments.

All other trademarks are the property of their respective owners.

### 11.5 静电放电警告



ESD 可能会损坏该集成电路。德州仪器 (TI) 建议通过适当的预防措施处理所有集成电路。如果不遵守正确的处理措施和安装程序，可能会损坏集成电路。

ESD 的损坏小至导致微小的性能降级，大至整个器件故障。精密的集成电路可能更容易受到损坏，这是因为非常细微的参数更改都可能会导致器件与其发布的规格不相符。

### 11.6 Glossary

[SLYZ022](#) — *TI Glossary*.

This glossary lists and explains terms, acronyms, and definitions.

## 12 机械、封装和可订购信息

以下页面包含机械、封装和可订购信息。这些信息是指定器件的最新可用数据。数据如有变更，恕不另行通知，且不会对此文档进行修订。如需获取此数据表的浏览器版本，请查阅左侧的导航栏。

## 重要声明和免责声明

TI 均以“原样”提供技术性及其可靠性数据（包括数据表）、设计资源（包括参考设计）、应用或其他设计建议、网络工具、安全信息和其他资源，不保证其中不含任何瑕疵，且不做任何明示或暗示的担保，包括但不限于对适销性、适合某特定用途或不侵犯任何第三方知识产权的暗示担保。

所述资源可供专业开发人员应用TI 产品进行设计使用。您将对以下行为独自承担全部责任：(1) 针对您的应用选择合适的TI 产品；(2) 设计、验证并测试您的应用；(3) 确保您的应用满足相应标准以及任何其他安全、安保或其他要求。所述资源如有变更，恕不另行通知。TI 对您使用所述资源的授权仅限于开发资源所涉及TI 产品的相关应用。除此之外不得复制或展示所述资源，也不提供其它TI 或任何第三方的知识产权授权许可。如因使用所述资源而产生任何索赔、赔偿、成本、损失及债务等，TI 对此概不负责，并且您须赔偿由此对TI 及其代表造成的损害。

TI 所提供产品均受TI 的销售条款 (<http://www.ti.com.cn/zh-cn/legal/termsofsale.html>) 以及ti.com.cn上或随附TI产品提供的其他可适用条款的约束。TI提供所述资源并不扩展或以其他方式更改TI 针对TI 产品所发布的可适用的担保范围或担保免责声明。

邮寄地址：上海市浦东新区世纪大道 1568 号中建大厦 32 楼，邮政编码：200122  
Copyright © 2019 德州仪器半导体技术（上海）有限公司

**PACKAGING INFORMATION**

Orderable Device	Status (1)	Package Type	Package Drawing	Pins	Package Qty	Eco Plan (2)	Lead finish/ Ball material (6)	MSL Peak Temp (3)	Op Temp (°C)	Device Marking (4/5)	Samples
INA190A1QDCKRQ1	ACTIVE	SC70	DCK	6	3000	RoHS & Green	NIPDAU	Level-2-260C-1 YEAR	-40 to 125	1ES	<a href="#">Samples</a>
INA190A2QDCKRQ1	ACTIVE	SC70	DCK	6	3000	RoHS & Green	NIPDAU	Level-2-260C-1 YEAR	-40 to 125	1ET	<a href="#">Samples</a>
INA190A3QDCKRQ1	ACTIVE	SC70	DCK	6	3000	RoHS & Green	NIPDAU	Level-2-260C-1 YEAR	-40 to 125	1EU	<a href="#">Samples</a>
INA190A4QDCKRQ1	ACTIVE	SC70	DCK	6	3000	RoHS & Green	NIPDAU	Level-2-260C-1 YEAR	-40 to 125	1EV	<a href="#">Samples</a>
INA190A5QDCKRQ1	ACTIVE	SC70	DCK	6	3000	RoHS & Green	NIPDAU	Level-2-260C-1 YEAR	-40 to 125	1EW	<a href="#">Samples</a>

(1) The marketing status values are defined as follows:

**ACTIVE:** Product device recommended for new designs.

**LIFEBUY:** TI has announced that the device will be discontinued, and a lifetime-buy period is in effect.

**NRND:** Not recommended for new designs. Device is in production to support existing customers, but TI does not recommend using this part in a new design.

**PREVIEW:** Device has been announced but is not in production. Samples may or may not be available.

**OBSELETE:** TI has discontinued the production of the device.

(2) **RoHS:** TI defines "RoHS" to mean semiconductor products that are compliant with the current EU RoHS requirements for all 10 RoHS substances, including the requirement that RoHS substance do not exceed 0.1% by weight in homogeneous materials. Where designed to be soldered at high temperatures, "RoHS" products are suitable for use in specified lead-free processes. TI may reference these types of products as "Pb-Free".

**RoHS Exempt:** TI defines "RoHS Exempt" to mean products that contain lead but are compliant with EU RoHS pursuant to a specific EU RoHS exemption.

**Green:** TI defines "Green" to mean the content of Chlorine (Cl) and Bromine (Br) based flame retardants meet JS709B low halogen requirements of <=1000ppm threshold. Antimony trioxide based flame retardants must also meet the <=1000ppm threshold requirement.

(3) MSL, Peak Temp. - The Moisture Sensitivity Level rating according to the JEDEC industry standard classifications, and peak solder temperature.

(4) There may be additional marking, which relates to the logo, the lot trace code information, or the environmental category on the device.

(5) Multiple Device Markings will be inside parentheses. Only one Device Marking contained in parentheses and separated by a "~" will appear on a device. If a line is indented then it is a continuation of the previous line and the two combined represent the entire Device Marking for that device.

(6) Lead finish/Ball material - Orderable Devices may have multiple material finish options. Finish options are separated by a vertical ruled line. Lead finish/Ball material values may wrap to two lines if the finish value exceeds the maximum column width.

**Important Information and Disclaimer:** The information provided on this page represents TI's knowledge and belief as of the date that it is provided. TI bases its knowledge and belief on information provided by third parties, and makes no representation or warranty as to the accuracy of such information. Efforts are underway to better integrate information from third parties. TI has taken and continues to take reasonable steps to provide representative and accurate information but may not have conducted destructive testing or chemical analysis on incoming materials and chemicals. TI and TI suppliers consider certain information to be proprietary, and thus CAS numbers and other limited information may not be available for release.

In no event shall TI's liability arising out of such information exceed the total purchase price of the TI part(s) at issue in this document sold by TI to Customer on an annual basis.

## TAPE AND REEL INFORMATION



### QUADRANT ASSIGNMENTS FOR PIN 1 ORIENTATION IN TAPE



\*All dimensions are nominal

Device	Package Type	Package Drawing	Pins	SPQ	Reel Diameter (mm)	Reel Width W1 (mm)	A0 (mm)	B0 (mm)	K0 (mm)	P1 (mm)	W (mm)	Pin1 Quadrant
INA190A1QDCKRQ1	SC70	DCK	6	3000	180.0	8.4	2.47	2.3	1.25	4.0	8.0	Q3
INA190A2QDCKRQ1	SC70	DCK	6	3000	180.0	8.4	2.47	2.3	1.25	4.0	8.0	Q3
INA190A3QDCKRQ1	SC70	DCK	6	3000	180.0	8.4	2.47	2.3	1.25	4.0	8.0	Q3
INA190A4QDCKRQ1	SC70	DCK	6	3000	180.0	8.4	2.47	2.3	1.25	4.0	8.0	Q3
INA190A5QDCKRQ1	SC70	DCK	6	3000	180.0	8.4	2.47	2.3	1.25	4.0	8.0	Q3

**TAPE AND REEL BOX DIMENSIONS**

\*All dimensions are nominal

Device	Package Type	Package Drawing	Pins	SPQ	Length (mm)	Width (mm)	Height (mm)
INA190A1QDCKRQ1	SC70	DCK	6	3000	213.0	191.0	35.0
INA190A2QDCKRQ1	SC70	DCK	6	3000	213.0	191.0	35.0
INA190A3QDCKRQ1	SC70	DCK	6	3000	213.0	191.0	35.0
INA190A4QDCKRQ1	SC70	DCK	6	3000	213.0	191.0	35.0
INA190A5QDCKRQ1	SC70	DCK	6	3000	213.0	191.0	35.0

DCK (R-PDSO-G6)

PLASTIC SMALL-OUTLINE PACKAGE

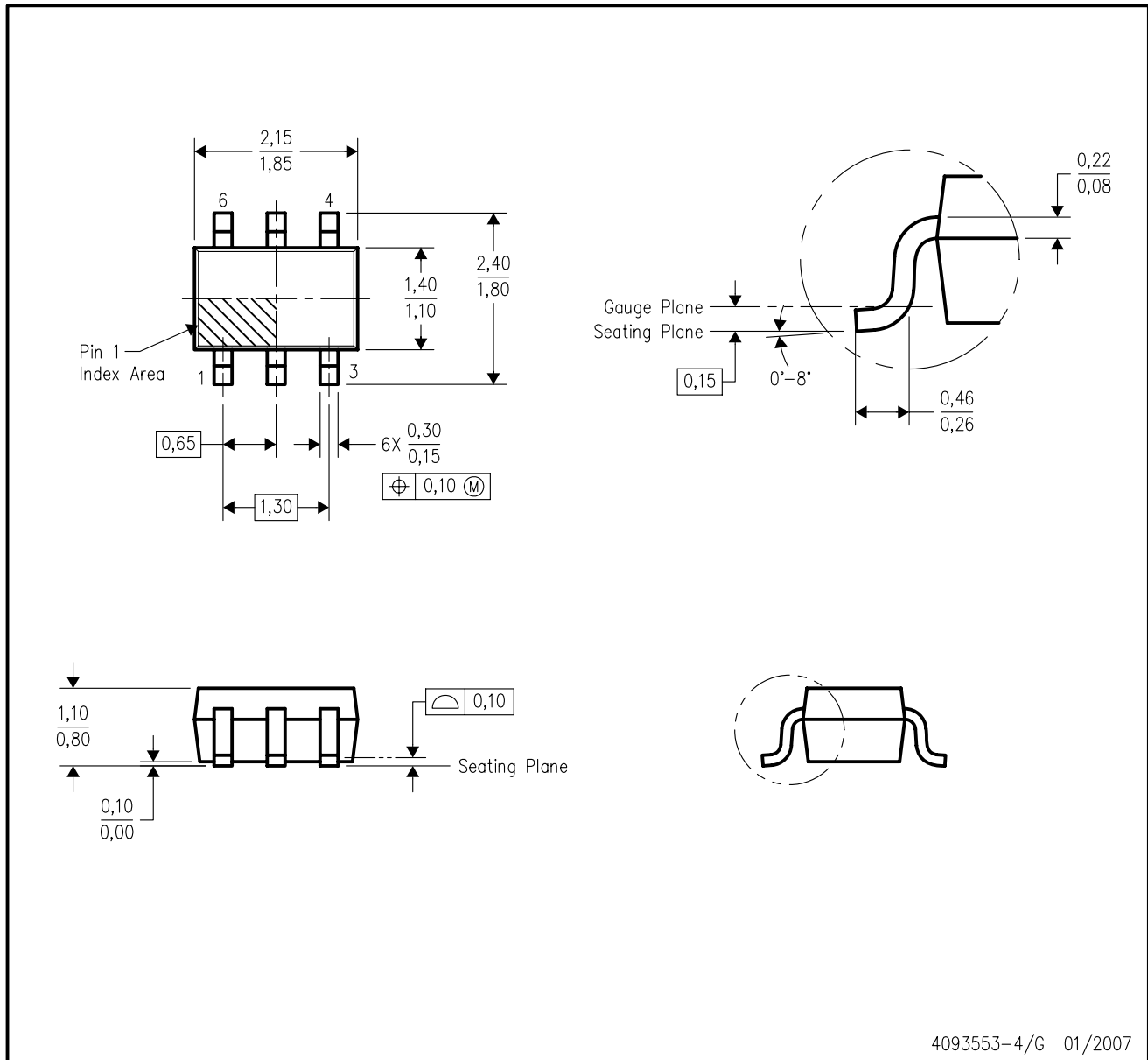

- NOTES:
- A. All linear dimensions are in millimeters.
  - B. This drawing is subject to change without notice.
  - C. Body dimensions do not include mold flash or protrusion. Mold flash and protrusion shall not exceed 0.15 per side.
  - D. Falls within JEDEC MO-203 variation AB.

DCK (R-PDSO-G6)

PLASTIC SMALL OUTLINE

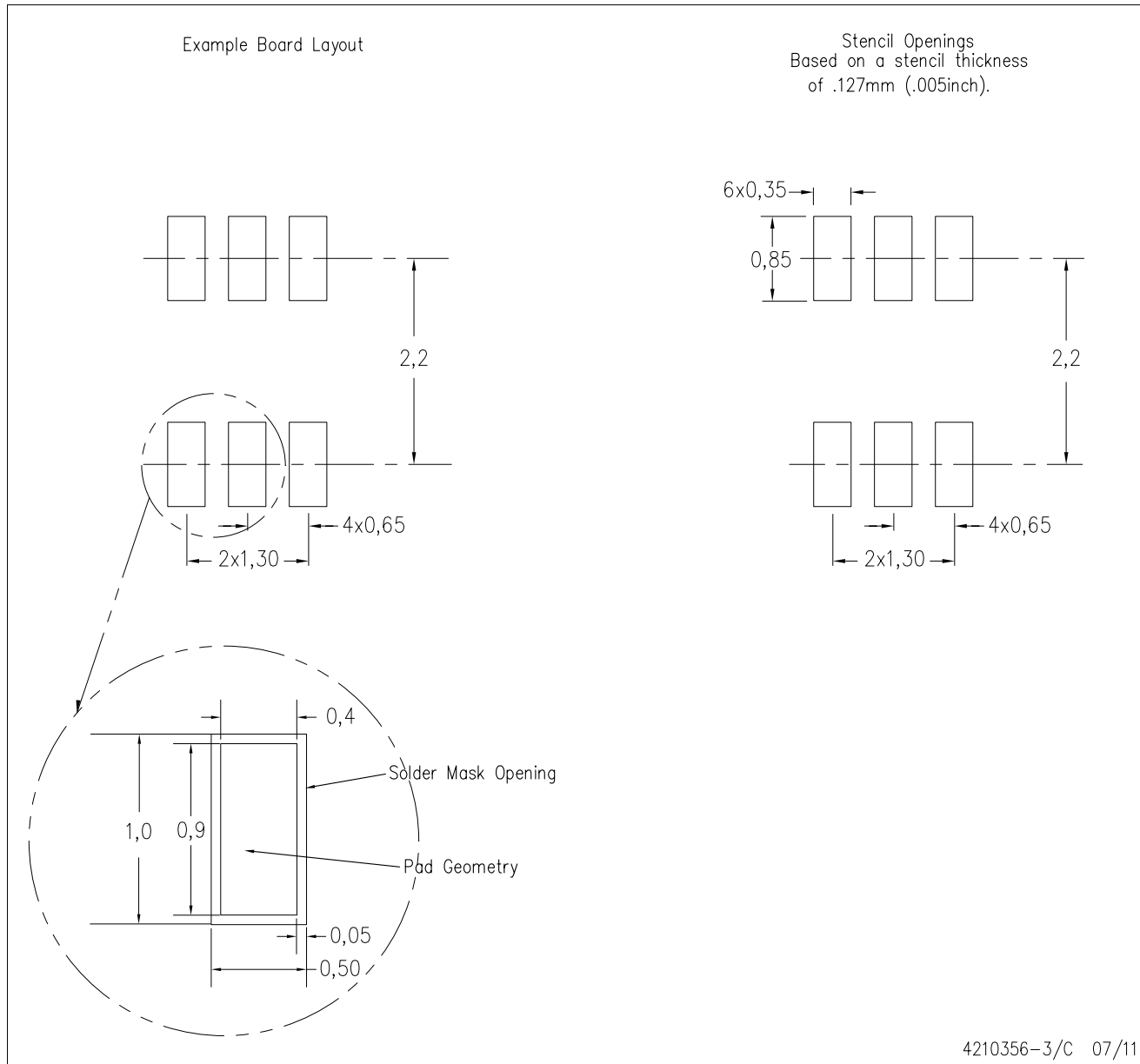

- NOTES:
- A. All linear dimensions are in millimeters.
  - B. This drawing is subject to change without notice.
  - C. Customers should place a note on the circuit board fabrication drawing not to alter the center solder mask defined pad.
  - D. Publication IPC-7351 is recommended for alternate designs.
  - E. Laser cutting apertures with trapezoidal walls and also rounding corners will offer better paste release. Customers should contact their board assembly site for stencil design recommendations. Example stencil design based on a 50% volumetric metal load solder paste. Refer to IPC-7525 for other stencil recommendations.

## 重要声明和免责声明

TI 均以“原样”提供技术性及其可靠性数据（包括数据表）、设计资源（包括参考设计）、应用或其他设计建议、网络工具、安全信息和其他资源，不保证其中不含任何瑕疵，且不做任何明示或暗示的担保，包括但不限于对适销性、适合某特定用途或不侵犯任何第三方知识产权的暗示担保。

所述资源可供专业开发人员应用TI 产品进行设计使用。您将对以下行为独自承担全部责任：(1) 针对您的应用选择合适的TI 产品；(2) 设计、验证并测试您的应用；(3) 确保您的应用满足相应标准以及任何其他安全、安保或其他要求。所述资源如有变更，恕不另行通知。TI 对您使用所述资源的授权仅限于开发资源所涉及TI 产品的相关应用。除此之外不得复制或展示所述资源，也不提供其它TI 或任何第三方的知识产权授权许可。如因使用所述资源而产生任何索赔、赔偿、成本、损失及债务等，TI 对此概不负责，并且您须赔偿由此对TI 及其代表造成的损害。

TI 所提供产品均受TI 的销售条款 (<http://www.ti.com.cn/zh-cn/legal/termsofsale.html>) 以及ti.com.cn 上或随附TI 产品提供的其他可适用条款的约束。TI 提供所述资源并不扩展或以其他方式更改TI 针对TI 产品所发布的可适用的担保范围或担保免责声明。

邮寄地址：上海市浦东新区世纪大道 1568 号中建大厦 32 楼，邮政编码：200122

Copyright © 2020 德州仪器半导体技术（上海）有限公司