

bq51010B 符合 Qi (WPC v1.1) 标准的高度集成无线接收器电源

1 特性

- 具有 7V 稳压电源的集成无线电源接收器解决方案
 - 93% 的整体峰值交流 (AC) -- 直流 (DC) 转换效率
 - 完全同步整流器
 - 符合 WPC v1.1 标准的通信控制
 - 输出电压调节
 - RX 线圈和 7V 输出之间仅需使用集成电路 (IC)
- 符合 WPC v1.1 标准的 (FOD 被启用) 高精度电流感测
- 针对经改进的负载瞬态响应的动态整流器控制
- 可在宽泛的输出电源范围内优化性能的动态效率调节
- 针对稳健通信的自适应通信限制
- 支持 20V 最高输入电压
- 低功率耗散整流器过压钳位 ($V_{OVP} = 15V$)
- 热关断
- 用于温度监控、充电完成和故障主机控制的多功能负温度系数热敏电阻 (NTC) 和控制引脚

2 应用

- 符合 WPC v1.1 标准的接收器
- 手机和智能电话
- 耳机
- 数码摄像机
- 便携式媒体播放器
- 手持设备

3 说明

bq51010B 是一系列灵活的高级次级侧器件，适用于便携式应用中的无线功率传输。bq51010B 器件提供 AC-DC 电源转换和稳压功能，同时集成了所需数字控制功能，符合 Qi v1.1 通信协议。bq51010B 与 bq50xxx 初级侧控制器相结合，可为无线电源解决方案实现一款完整的非接触式功率传输系统。使用 Qi v1.1 协议需要在次级侧与初级侧之间建立全局反馈，从而控制功率传输过程。

bq51010B 器件集成了一个低电阻同步整流器、低压降稳压器、数字控制和精确电压和电流回路，可确保高效率和低功耗。

bq51010B 还包括一个数字控制器，可用于计算移动设备接收的电量，该值不超过 WPC v1.1 标准设定的限值。此后，控制器将该信息传输至发送器，以便其确定磁性界面上是否存在外来物体以及是否需要提升磁场内的安全级别。该外来物体检测 (FOD) 方法属于 WPC v1.1 规范中要求的一部分。

器件信息 (1)

部件号	封装	封装尺寸 (标称值)
bq51010B	DSBGA (28)	1.90mm x 3.00mm

(1) 要了解所有可用封装，请参见数据表末尾的可订购产品附录。

无线充电联盟 (WPC 或者 Qi) 感性电源系统

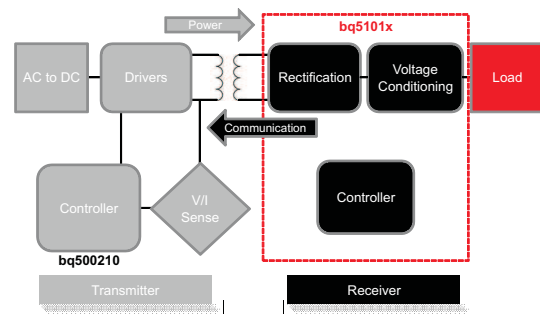

目录

1	特性	1	8.4	Device Functional Modes.....	23
2	应用	1	9	Application and Implementation	24
3	说明	1	9.1	Application Information.....	24
4	修订历史记录	2	9.2	Typical Applications	24
5	Device Comparison Tables	3	10	Power Supply Recommendations	31
6	Pin Configuration and Functions	3	11	Layout.....	31
7	Specifications.....	5	11.1	Layout Guidelines	31
7.1	Absolute Maximum Ratings	5	11.2	Layout Example	31
7.2	ESD Ratings.....	5	12	器件和文档支持	32
7.3	Recommended Operating Conditions.....	5	12.1	器件支持	32
7.4	Thermal Information	5	12.2	文档支持	32
7.5	Electrical Characteristics.....	6	12.3	接收文档更新通知	32
7.6	Typical Characteristics	8	12.4	社区资源	32
8	Detailed Description	10	12.5	商标	32
8.1	Overview	10	12.6	静电放电警告	32
8.2	Functional Block Diagram	11	12.7	Glossary	32
8.3	Feature Description.....	11	13	机械、封装和可订购信息	32

4 修订历史记录

Changes from Original (December 2012) to Revision A

Page

- 已添加 ESD 额定值表，特性 描述部分，器件功能模式，应用和 实施部分，电源相关建议部分，布局部分，器件和文档支持部分以及机械、封装和可订购信息部分..... **1**
- 删除了封装概要，请参见数据表末尾的 POA..... **1**

5 Device Comparison Tables

DEVICE	FUNCTION	V _{OUT} (V _{BAT-REG})	PROTOCOL	MAXIMUM P _{OUT}	I ² C
bq51003	Wireless receiver	5 V	Qi v1.1	2.5 W	No
bq51013B	Wireless receiver	5 V	Qi v1.1	5 W	No
bq51010B	Wireless receiver	7 V	Qi v1.1	5 W	No
bq51020	Wireless receiver	4.5 to 8 V	Qi v1.1	5 W	No
bq51021	Wireless receiver	4.5 to 8 V	Qi v1.1	5 W	Yes
bq51221	Dual mode wireless receiver	4.5 to 8 V	Qi v1.1, PMA	5 W	Yes
bq51025	Wireless receiver	4.5 to 10 V	Qi v1.1 (in 5 W mode)	10 W	Yes
bq51020B	Wireless receiver and direct charger	4.2 V	Qi v1.1	5 W	No
bq51051B	Wireless receiver and direct charger	4.35 V	Qi v1.1	5 W	No
bq51052B	Wireless receiver and direct charger	4.4 V	Qi v1.1	5 W	No

Table 1. Device Options

DEVICE	FUNCTION	WPC VERSION	V _{RECT-OVP}	V _{OUT-(REG)}	OVER CURRENT SHUTDOWN	AD-OVP	TERMINATION	COMMUNICATION CURRENT LIMIT ⁽¹⁾⁽²⁾
bq51010B	7-V power supply	v1.1	15 V	7 V	Disabled	Disabled	Disabled	Adaptive + 1s Hold-Off

- (1) Enabled if EN2 is low and disabled if EN2 is high
(2) Communication current limit is disabled for 1 second at start-up

6 Pin Configuration and Functions

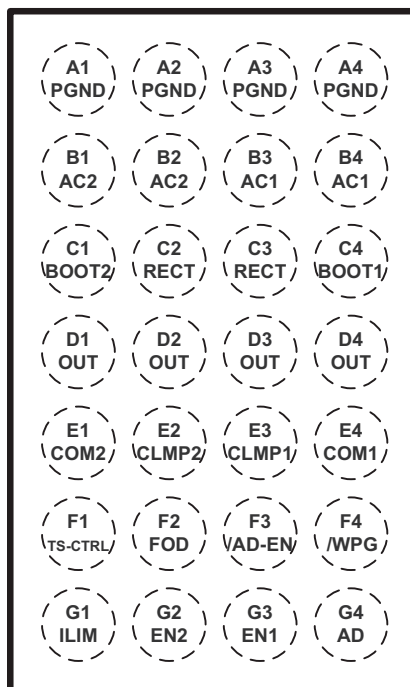
**YFP Package
28-Pin DSBGA
Top View**

Pin Functions

PIN		I/O	DESCRIPTION
NAME	NO.		
AC1	B3, B4	I	AC input from receiver coil antenna.
AC2	B1, B2	I	
AD	G4	I	Connect this pin to the wired adapter input. When a voltage is applied to this pin wireless charging is disabled and AD_EN is driven low. Connect to GND through a 1- μ F capacitor. If unused, capacitor is not required and must be grounded directly.
$\overline{\text{AD-EN}}$	F3	O	Push-pull driver for external PFET connecting AD and OUT. This node is pulled to the higher of OUT and AD when turning off the external FET. This voltage tracks approximately 4 V below AD when voltage is present at AD and provides a regulated VSG bias for the external FET. Float this pin if unused.
BOOT1	C4	O	Bootstrap capacitors for driving the high-side FETs of the synchronous rectifier. Connect a 10-nF ceramic capacitor from BOOT1 to AC1 and from BOOT2 to AC2.
BOOT2	C1	O	
CLMP1	E3	O	Open drain FETs are used for a non-power dissipative overvoltage AC clamp protection. When the RECT voltage goes above 15 V, both switches is turned on and the capacitors acts as a low impedance to protect the IC from damage. If used, Clamp1 is required to be connected to AC1, and Clamp2 is required to be connected to AC2 through 0.47- μ F capacitors.
CLMP2	E2	O	
COM1	E4	O	Open-drain output used to communicate with primary by varying reflected impedance. Connect through a capacitor to either AC1 or AC2 for capacitive load modulation (COM2 must be connected to the alternate AC1 or AC2 pin). For resistive modulation connect COM1 and COM2 to RECT through a single resistor; connect through separate capacitors for capacitive load modulation.
COM2	E1	O	
EN1	G3	I	Inputs that allow user to enable or disable wireless and wired charging <EN1 EN2>: <00> wireless charging is enabled unless AD voltage > 3.6 V <01> Dynamic communication current limit disabled <10> AD-EN pulled low, wireless charging disabled <11> wired and wireless charging disabled.
EN2	G2	I	
FOD	F2	I	Input for the received power measurement. Connect to GND with a 140- Ω resistor. See the FOD section for more detail.
ILIM	G1	I/O	Programming pin for the over current limit. Connect external resistor to VSS. Size R_{ILIM} with the following equation: $R_{ILIM} = 314 / I_{MAX}$ where I_{MAX} is the expected maximum output current of the wireless power supply. The hardware current limit (ILIM) is 20% greater than I_{MAX} or $1.2 \times I_{MAX}$. If the supply is meant to operate in current limit use: $R_{ILIM} = 314 / I_{ILIM}$, $R_{ILIM} = R1 + R_{FOD}$
OUT	D1, D2, D3, D4	O	Output pin, delivers power to the load.
PGND	A1, A2, A3, A4	—	Power ground
RECT	C2, C3	O	Filter capacitor for the internal synchronous rectifier. Connect a ceramic capacitor to PGND. Depending on the power levels, the value may be 4.7 μ F to 22 μ F.
TS/CTRL	F1	I	Must be connected to ground through a resistor. If an NTC function is not desired connect to GND with a 10-k Ω resistor. As a CTRL pin pull to ground to send end power transfer (EPT) fault to the transmitter or pull-up to an internal rail (that is, 1.8 V) to send EPT termination to the transmitter. Note that a 3-state driver must be used to interface this pin (see the 3-State Driver Recommendations For the TS-CTRL Pin section for further description)
$\overline{\text{WPG}}$	F4	O	Open-drain output – Active when the output of the wireless power supply is enabled.

7 Specifications

7.1 Absolute Maximum Ratings

over operating free-air temperature range (unless otherwise noted)⁽¹⁾⁽²⁾

		MIN	MAX	UNIT
Input voltage	AC1, AC2	-0.8	20	V
	RECT, COM1, COM2, OUT, \overline{WPG} , CLAMP1, CLAMP2	-0.3	20	
	AD, $\overline{AD-EN}$	-0.3	30	
	BOOT1, BOOT2	-0.3	26	
	EN1, EN2, TERM, FOD, TS-CTRL, ILIM	-0.3	7	
Input current	AC1, AC2		1.5	A(RMS)
Output current	OUT		750	mA
Output sink current	\overline{WPG}		15	mA
	COM1, COM2		1	A
Junction temperature, T_J		-40	150	°C
Storage temperature, T_{stg}		-65	150	°C

- (1) Stresses beyond those listed under *Absolute Maximum Ratings* may cause permanent damage to the device. These are stress ratings only, which do not imply functional operation of the device at these or any other conditions beyond those indicated under *Recommended Operating Conditions*. Exposure to absolute-maximum-rated conditions for extended periods may affect device reliability.
- (2) All voltages are with respect to the VSS terminal, unless otherwise noted.

7.2 ESD Ratings

		VALUE	UNIT
$V_{(ESD)}$ Electrostatic discharge	Human-body model (HBM), per ANSI/ESDA/JEDEC JS-001 ⁽¹⁾	±2000	V
	Charged-device model (CDM), per JEDEC specification JESD22-C101 ⁽²⁾	±500	

- (1) JEDEC document JEP155 states that 500-V HBM allows safe manufacturing with a standard ESD control process.
- (2) JEDEC document JEP157 states that 250-V CDM allows safe manufacturing with a standard ESD control process.

7.3 Recommended Operating Conditions

over operating free-air temperature range (unless otherwise noted)

			MIN	MAX	UNIT
V_{RECT}	Voltage range	RECT	4	10	V
I_{RECT}	Current through internal rectifier	RECT		1	A
I_{OUT}	Output current	OUT		750	mA
I_{AD-EN}	Sink current	$\overline{AD-EN}$		1	mA
I_{COMM}	COMM sink current	COMM		400	mA
T_J	Junction temperature		0	125	°C

7.4 Thermal Information

THERMAL METRIC ⁽¹⁾		bq51010B	UNIT
		YFP (DSBGA)	
		28 PINS	
$R_{\theta JA}$	Junction-to-ambient thermal resistance	58.9	°C/W
$R_{\theta JC(top)}$	Junction-to-case (top) thermal resistance	0.2	°C/W
$R_{\theta JB}$	Junction-to-board thermal resistance	9.1	°C/W
Ψ_{JT}	Junction-to-top characterization parameter	1.4	°C/W
Ψ_{JB}	Junction-to-board characterization parameter	8.9	°C/W
$R_{\theta JC(bot)}$	Junction-to-case (bottom) thermal resistance	—	°C/W

- (1) For more information about traditional and new thermal metrics, see the [Semiconductor and IC Package Thermal Metrics](#) application report.

7.5 Electrical Characteristics

over operating free-air temperature range, 0°C to 125°C (unless otherwise noted)

PARAMETER		TEST CONDITIONS	MIN	TYP	MAX	UNIT
UVLO	Undervoltage lockout	$V_{RECT} = 0\text{ V to }3\text{ V}$	2.6	2.7	2.8	V
V_{HYS}	Hysteresis on UVLO	$V_{RECT} = 3\text{ V to }2\text{ V}$	250			mV
	Hysteresis on OVP	$V_{RECT} = 16\text{ V to }5\text{ V}$	150			
V_{RECT}	Input overvoltage threshold	$V_{RECT} = 5\text{ V to }16\text{ V}$	14.5	15	15.5	V
$V_{RECT-REG}$	Dynamic V_{RECT} threshold 1	$I_{LOAD} < 0.1 \times I_{IMAX}$ (I_{LOAD} rising)	9.08			V
	Dynamic V_{RECT} threshold 2	$0.1 \times I_{IMAX} < I_{LOAD} < 0.2 \times I_{IMAX}$ (I_{LOAD} rising)	8.28			
	Dynamic V_{RECT} threshold 3	$0.2 \times I_{IMAX} < I_{LOAD} < 0.4 \times I_{IMAX}$ (I_{LOAD} rising)	7.53			
	Dynamic V_{RECT} threshold 4	$I_{LOAD} > 0.4 \times I_{IMAX}$ (I_{LOAD} rising)	7.11			
	V_{RECT} tracking	In current limit voltage above V_{OUT}	$V_O + 0.25$			
I_{LOAD}	I_{LOAD} hysteresis for dynamic V_{RECT} thresholds as a percentage of I_{LIM}	I_{LOAD} falling	4%			
$V_{RECT-DPM}$	Rectifier undervoltage protection, restricts I_{OUT} at $V_{RECT-DPM}$		3	3.1	3.2	V
$V_{RECT-REV}$	Rectifier reverse voltage protection at the output	$V_{RECT-REV} = V_{OUT} - V_{RECT}$, $V_{OUT} = 10\text{ V}$	8 9			V
QUIESCENT CURRENT						
I_{RECT}	Active chip quiescent current consumption from RECT	$I_{LOAD} = 0\text{ mA}$, $0^\circ\text{C} \leq T_J \leq 85^\circ\text{C}$	8 10			mA
		$I_{LOAD} = 300\text{ mA}$, $0^\circ\text{C} \leq T_J \leq 85^\circ\text{C}$	2 3			
I_{OUT}	Quiescent current at the output when wireless power is disabled (standby)	$V_{OUT} = 7\text{ V}$, $0^\circ\text{C} \leq T_J \leq 85^\circ\text{C}$	28 40			μA
I_{LIM} SHORT CIRCUIT						
R_{ILIM}	Highest value of I_{LIM} resistor considered a fault (short). Monitored for $I_{OUT} > 100\text{ mA}$	$R_{ILIM} = 200\ \Omega$ to $50\ \Omega$. I_{OUT} latches off, cycle power to reset	120			Ω
t_{DGL}	Deglintch time transition from I_{LIM} short to I_{OUT} disable		1			ms
I_{LIM_SC}	$I_{LIM_SHORT_OK}$ enables the I_{LIM} short comparator when I_{OUT} is greater than this value	$I_{LOAD} = 0\text{ mA to }200\text{ mA}$	110	145	165	mA
	Hysteresis for $I_{LIM_SHORT_OK}$ comparator	$I_{LOAD} = 0\text{ mA to }200\text{ mA}$	30			
I_{OUT}	Maximum output current limit, C_L	Maximum I_{LOAD} that is delivered for 1 ms when I_{LIM} is shorted	2.45			A
OUTPUT						
$V_{OUT-REG}$	Regulated output voltage	$I_{LOAD} = 750\text{ mA}$	6.9	6.96	7.02	V
		$I_{LOAD} = 10\text{ mA}$	6.9	6.95	7.05	
K_{ILIM}	Current programming factor for hardware protection	$R_{LIM} = K_{ILIM} / I_{LIM}$, where I_{LIM} is the hardware current limit. $I_{OUT} = 750\text{ mA}$	303	314	322	$\text{A}\Omega$
K_{IMAX}	Current programming factor for the nominal operating current	$I_{IMAX} = K_{IMAX} / R_{LIM}$, where I_{IMAX} is the maximum normal operating current. $I_{OUT} = 750\text{ mA}$	262			$\text{A}\Omega$
I_{OUT}	Current limit programming range		1.5			A
I_{COMM}	Current limit during WPC communication	$I_{OUT} > 300\text{ mA}$	$I_{OUT} + 50$			mA
		$I_{OUT} < 300\text{ mA}$	343	378	425	
t_{HOLD}	Hold off time for the communication current limit during start-up		1			s

Electrical Characteristics (continued)

over operating free-air temperature range, 0°C to 125°C (unless otherwise noted)

PARAMETER		TEST CONDITIONS	MIN	TYP	MAX	UNIT
TS / CTRL						
V _{TS}	Internal TS bias voltage	I _{TS-Bias} < 100 μA (periodically driven see t _{TS-CTRL})	2	2.2	2.4	V
V _{COLD}	Rising threshold	V _{TS} = 50% to 60%	56.5%	58.7%	60.8%	V _{TS-Bias}
	Falling hysteresis	V _{TS} = 60% to 50%	2%			
V _{HOT}	Falling threshold	V _{TS} = 20% to 15%	18.5%	19.6%	20.7%	V _{TS-Bias}
	Rising hysteresis	V _{TS} = 15% to 20%	3%			
V _{CTRL}	CTRL pin threshold for a high	V _{TS/CTRL} = 50 mV to 150 mV	80	100	130	mV
	CTRL pin threshold for a low	V _{TS/CTRL} = 150 mV to 50 mV	50	80	100	
t _{TS-CTRL}	Time VTS-Bias is active when TS measurements occur	Synchronous to the communication period	24			ms
t _{TS}	Deglintch time for all TS comparators		10			ms
R _{TS}	Pullup resistor for the NTC network. Pulled up to the voltage bias		18	20	22	kΩ
THERMAL PROTECTION						
T _J	Thermal shutdown temperature		155			°C
	Thermal shutdown hysteresis		20			
OUTPUT LOGIC LEVELS ON $\overline{\text{WPG}}$						
V _{OL}	Open drain $\overline{\text{WPG}}$ pin	I _{SINK} = 5 mA	500			mV
I _{OFF}	$\overline{\text{WPG}}$ leakage current when disabled	V _{$\overline{\text{WPG}}$} = 20 V	1			μA
COMM PIN						
R _{DS(ON)}	COM1 and COM2	V _{RECT} = 2.6 V	1.5			Ω
f _{COMM}	Signaling frequency on COMM pin		2			Kb/s
I _{OFF}	Comm pin leakage current	V _{COM1} = 20 V, V _{COM2} = 20 V	1			μA
CLAMP PIN						
R _{DS(ON)}	Clamp1 and Clamp2		0.8			Ω
ADAPTER ENABLE						
V _{$\overline{\text{AD-EN}}$}	V _{AD} rising threshold voltage. EN-UVLO	V _{AD} = 0 V to 5 V	3.5	3.6	3.8	V
	V _{$\overline{\text{AD-EN}}$} hysteresis, EN-HYS	V _{AD} = 5 V to 0 V	400			mV
I _{AD}	Input leakage current	V _{RECT} = 0 V, V _{AD} = 5 V	60			μA
R _{AD}	Pullup resistance from $\overline{\text{AD-EN}}$ to OUT when adapter mode is disabled and V _{OUT} > V _{AD} , EN-OUT	V _{AD} = 0 V, V _{OUT} = 5 V	200	350		Ω
V _{AD}	Voltage difference between V _{AD} and V _{$\overline{\text{AD-EN}}$} when adapter mode is enabled, EN-ON	V _{AD} = 5 V, 0°C ≤ T _J ≤ 85°C	3	4.5	5	V
SYNCHRONOUS RECTIFIER						
I _{OUT}	I _{OUT} at which the synchronous rectifier enters half-synchronous mode, SYNC_EN	I _{LOAD} = 200 mA to 0 mA	80	100	130	mA
	Hysteresis for I _{OUT,RECT-EN} (full-synchronous mode enabled)	I _{LOAD} = 0 mA to 200 mA	25			
V _{HS-DIODE}	High-side diode drop when the rectifier is in half-synchronous mode	I _{AC-VRECT} = 250 mA and T _J = 25°C	0.7			V
EN1 AND EN2						
V _{IL}	Input low threshold for EN1 and EN2		0.4			V
V _{IH}	Input high threshold for EN1 and EN2		1.3			V
R _{PD}	EN1 and EN2 pull down resistance		200			kΩ
ADC (WPC RELATED MEASUREMENTS AND COEFFICIENTS)						
I _{OUT SENSE}	Accuracy of the current sense over the load range	I _{OUT} = 0 mA to 750 mA	-1.5%	0%	0.9%	

7.6 Typical Characteristics

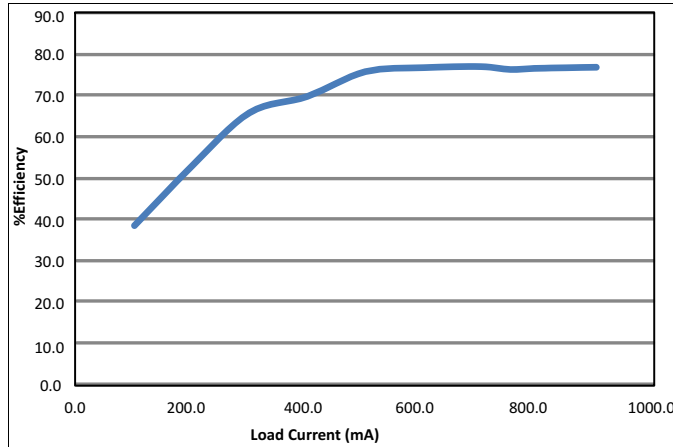

Figure 1. System Efficiency from DC Input to DC Output

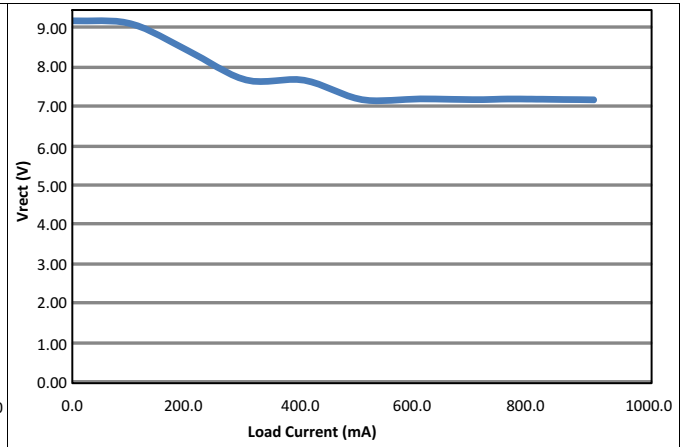

Figure 2. V_{RECT} vs Load Current

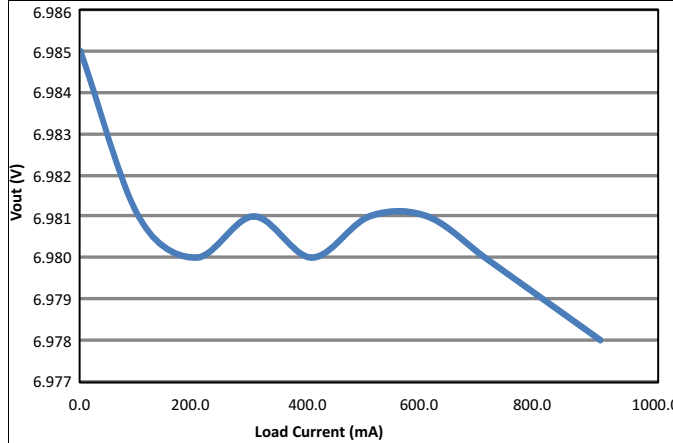

Figure 3. Load Current Sweep (I-V Curve)

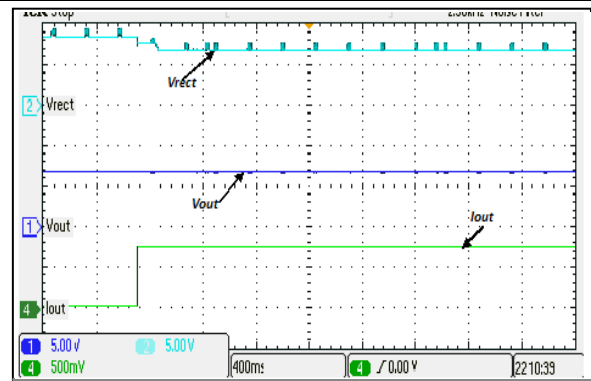

Figure 4. 720-mA Load Step Full System Response

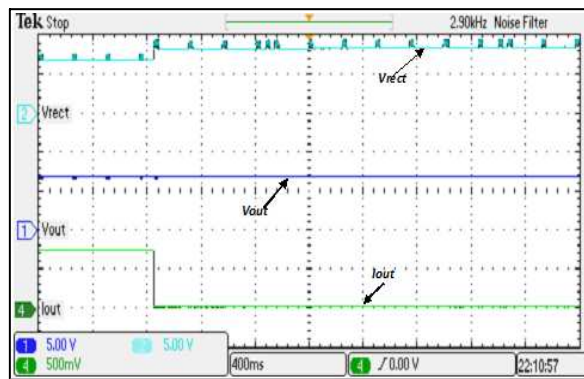

Figure 5. 720-mA Load Dump Full System Response

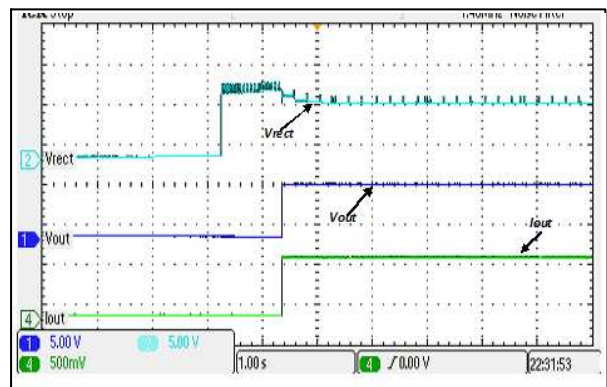

Figure 6. Typical Start-Up With a 720-mA System Load

Typical Characteristics (continued)

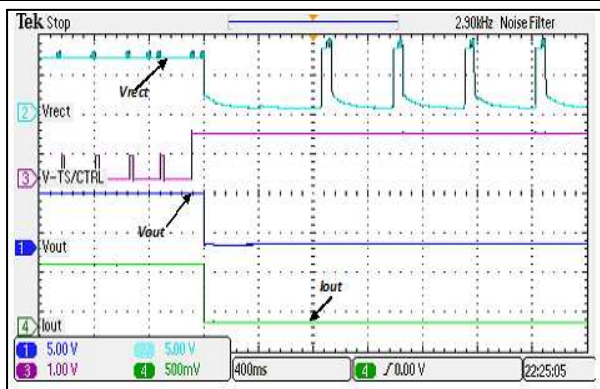

Figure 7. TS Fault

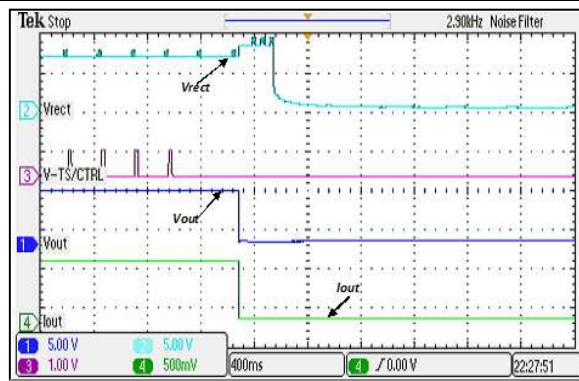

Figure 8. TS Fault GND

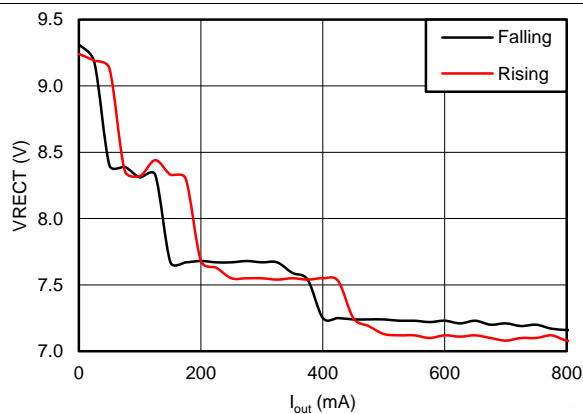

Figure 9. Impact of Load Current on Rectifier Voltage

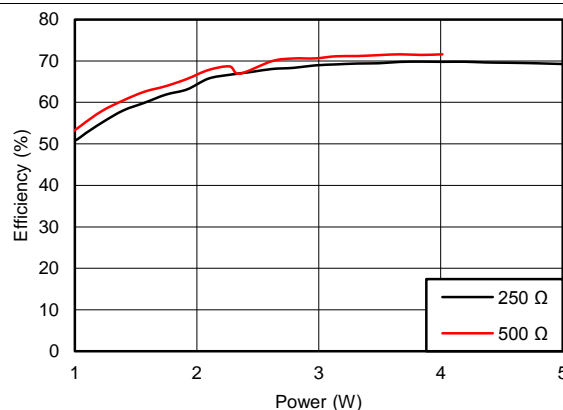

Figure 10. Light Load System Efficiency Improvement Due to Dynamic Efficiency Scaling Feature

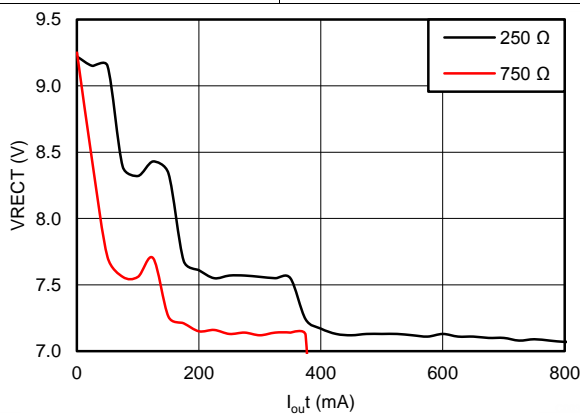

Figure 11. Impact of Maximum Current Setting on Rectifier Voltage

8 Detailed Description

8.1 Overview

The principle of the bq51010B wireless power transfer devices are simply to provide an open-cored transformer consisting of transmitter and receiver coils. The transmitter coil and electronics are built into a charger pad, and the receiver coil and electronics are typically built into a portable device such as a cell phone. When the receiver coil is positioned on the transmitter coil, magnetic coupling occurs when the transmitter coil is driven. The flux is coupled into the secondary coil, which induces a voltage and current flows. The secondary voltage is rectified, and power can be transferred effectively to a load wirelessly. Power transfer can be managed through any of the various closed-loop control schemes.

8.1.1 A Brief Description of the Wireless System

A wireless system consists of a charging pad (transmitter or primary) and the secondary-side equipment (receiver or secondary). There is a coil in the charging pad and in the secondary equipment which are magnetically coupled to each other when the secondary is placed on the primary. Power is then transferred from the transmitter to the receiver through coupled inductors (for example, an air-core transformer). Controlling the amount of power transferred is achieved by sending feedback (error signal) communication to the primary (for example, to increase or decrease power).

The receiver communicates with the transmitter by changing the load seen by the transmitter. This load variation results in a change in the transmitter coil current, which is measured and interpreted by a processor in the charging pad. Communication is done through digital-packets which are transferred from the receiver to the transmitter. Differential biphase encoding is used for the packets. The bit rate is 2-kbps.

Various types of communication packets have been defined. These include identification and authentication packets, error packets, control packets, end power packets, and power usage packets.

The transmitter coil stays powered off most of the time. It occasionally wakes up to see if a receiver is present. When a receiver authenticates itself to the transmitter, the transmitter remains powered on. The receiver maintains full control over the power transfer using communication packets.

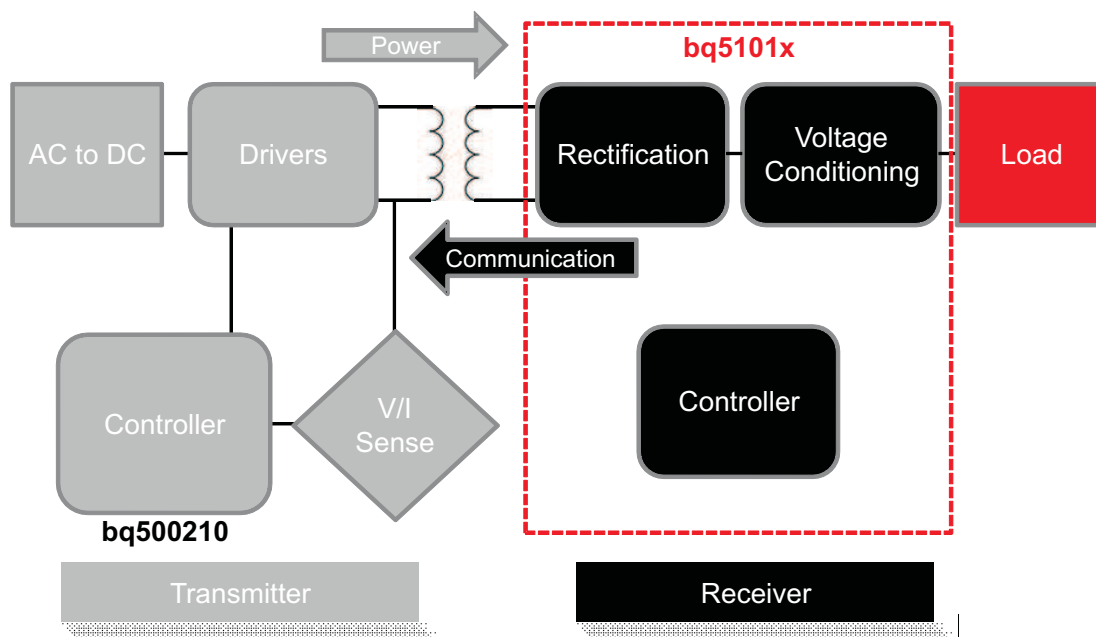
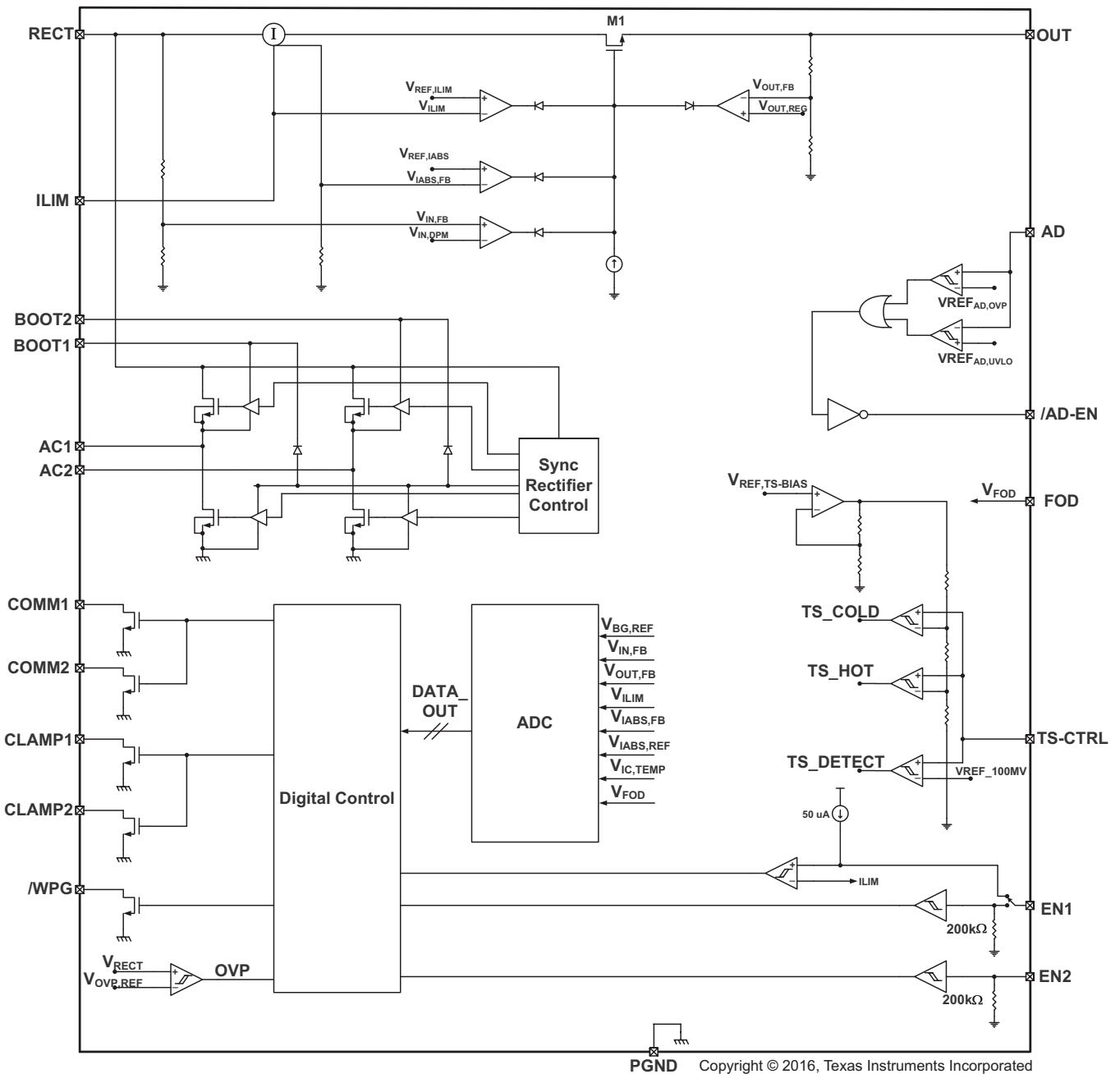

Figure 12. WPC Wireless Power System Indicating the Functional Integration of the bq51010B

8.2 Functional Block Diagram



8.3 Feature Description

8.3.1 Qi Wireless Power System and bq51010B Power Transfer Flow Diagrams

The bq51010B family integrates a fully compliant WPC v1.1 communication algorithm to streamline receiver designs (no extra software development required). Other unique algorithms such as Dynamic Rectifier Control are also integrated to provide best-in-class system performance. This section provides a high-level overview of these features by illustrating the wireless power transfer flow diagram from start-up to active operation.

Feature Description (continued)

During start-up operation, the wireless power receiver must comply with proper handshaking to be granted a power contract from the TX. The TX initiates the hand shake by providing an extended digital ping. If an RX is present on the TX surface, the RX then provides the signal strength, configuration, and identification packets to the TX (see volume 1 of the WPC specification for details on each packet). These are the first three packets sent to the TX. The only exception is if there is a true shutdown condition on the EN1 or EN2, the AD, or the TS-CTRL pins where the RX shuts down the TX immediately (see [Table 5](#) for details). Once the TX has successfully received the signal strength, configuration, and identification packets, the RX is granted a power contract and is then allowed to control the operating point of the power transfer. With the use of the Dynamic Rectifier Control algorithm, the RX informs the TX to adjust the rectifier voltage above 9 V prior to enabling the output supply. This method enhances the transient performance during system start-up (see [Figure 13](#) for the start-up flow diagram details).

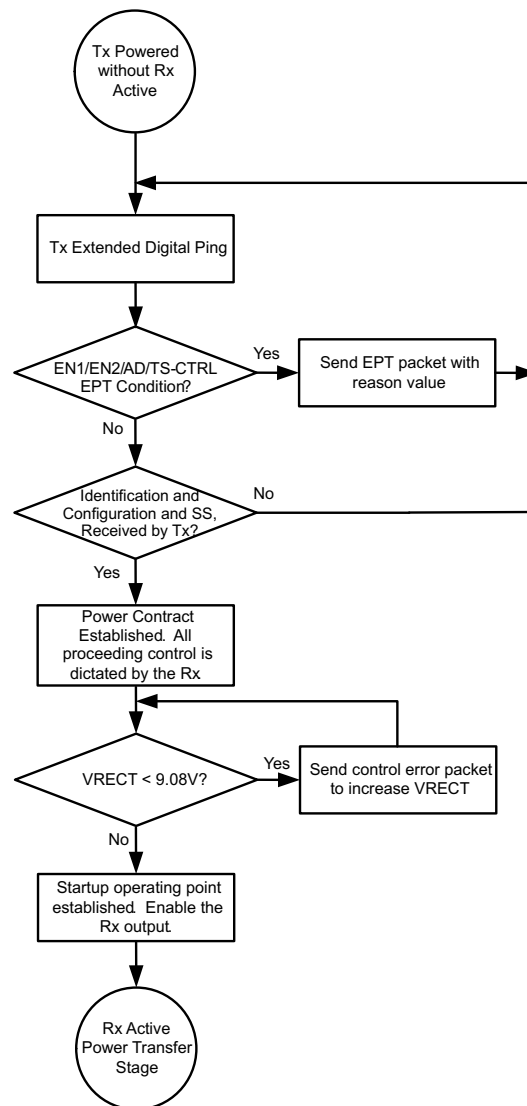
Figure 13. Wireless Power Start-Up Flow Diagram

Feature Description (continued)

Once the start-up procedure has been established, the RX enters the active power transfer stage. This is considered the *main loop* of operation. The Dynamic Rectifier Control algorithm determines the rectifier voltage target based on a percentage of the maximum output current level setting (set by $K_{I_{MAX}}$ and the I_{LIM} resistance to GND). The RX sends control error packets to converge on these targets. As the output current changes, the rectifier voltage target dynamically changes. As a note, the feedback loop of the WPC system is relatively slow where it can take up to 90 ms to converge on a new rectifier voltage target. It must be understood that the instantaneous transient response of the system is open loop and dependent on the RX coil output impedance at that operating point. The *main loop* also determines if any conditions in Table 5 are true to discontinue power transfer. See Figure 14 which illustrates the active power transfer loop.

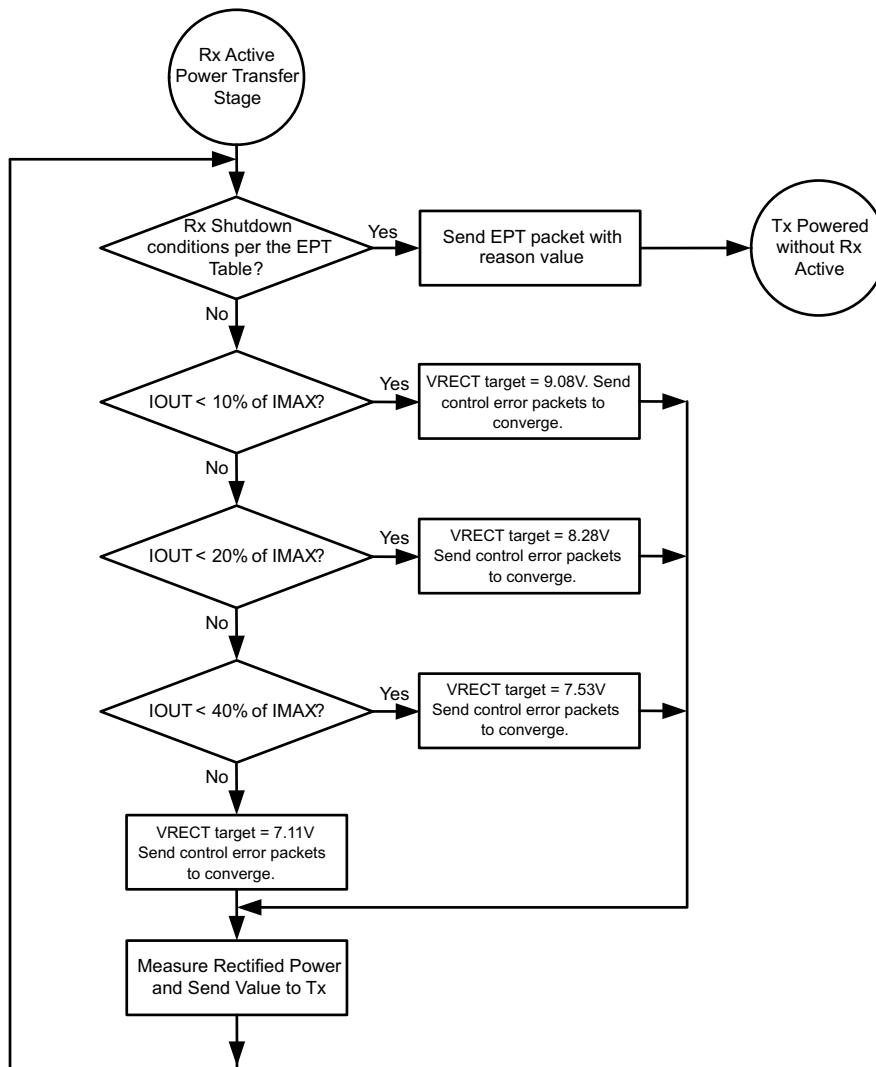

Figure 14. Active Power Transfer Flow Diagram

Another requirement of the WPC v1.1 specification is to send the measured received power. This task is enabled on the IC by measuring the voltage on the FOD pin which is proportional to the output current and can be scaled based on the choice of the resistor to ground on the FOD pin.

Feature Description (continued)

8.3.2 Dynamic Rectifier Control

The dynamic rectifier control algorithm offers the end system designer optimal transient response for a given max output current setting. This is achieved by providing enough voltage headroom across the internal regulator at light loads to maintain regulation during a load transient. The WPC system has a relatively slow global feedback loop where it can take more than 90 ms to converge on a new rectifier voltage target. Therefore, the transient response is dependent on the loosely coupled transformers output impedance profile. The dynamic rectifier control allows for a 2-V change in rectified voltage before the transient response is observed at the output of the internal regulator (output of the bq51010B). A 720-mA application allows up to a 1.5-Ω output impedance.

8.3.3 Dynamic Efficiency Scaling

The dynamic efficiency scaling feature allows for the loss characteristics of the bq51010B to be scaled based on the maximum expected output power in the end application. This effectively optimizes the efficiency for each application. This feature is achieved by scaling the loss of the internal LDO based on a percentage of the maximum output current. Note that the maximum output current is set by the $K_{I_{MAX}}$ term and the R_{ILIM} resistance (where $R_{ILIM} = K_{I_{MAX}} / I_{MAX}$). The flow diagram show in [Figure 14](#) illustrates how the rectifier is dynamically controlled (*Dynamic Rectifier Control*) based on a fixed percentage of the I_{MAX} setting. [Table 2](#) summarizes how the rectifier behavior is dynamically adjusted based on two different R_{ILIM} settings.

Table 2. Dynamic Efficiency Scaling

OUTPUT CURRENT PERCENTAGE	$R_{ILIM} = 890 \Omega$ $I_{MAX} = 0.35 \text{ A}$	$R_{ILIM} = 417 \Omega$ $I_{MAX} = 0.75 \text{ A}$	V_{RECT}
0% to 10%	0 A to 0.035 A	0 A to 0.075 A	9.08 V
10% to 20%	0.035 A to 0.07 A	0.075 A to 0.150 A	8.28 V
20% to 40%	0.07 A to 0.14 A	0.150 A to 0.225 A	7.53 V
>40%	>0.14 A	>0.225 A	7.11 V

8.3.4 R_{ILIM} Calculations

The bq51010B includes a means of providing hardware overcurrent protection by means of an analog current regulation loop. The hardware current limit provides an extra level of safety by clamping the maximum allowable output current (for example, a current compliance). The R_{ILIM} resistor size also sets the thresholds for the dynamic rectifier levels and thus providing efficiency tuning per the maximum system current of each application. Calculate the total R_{ILIM} resistance with [Equation 1](#).

$$R_{ILIM} = \frac{262}{I_{MAX}}$$

$$I_{ILIM} = 1.2 \times I_{MAX} = \frac{314}{R_{ILIM}}$$

$$R_{ILIM} = R_1 + R_{FOD}$$

where

- I_{MAX} is the expected maximum output current during normal operation
- I_{ILIM} is the hardware over current limit

(1)

When referring to the application diagram shown in [Figure 27](#), R_{ILIM} is the sum of R_{FOD} and the R_1 resistance (for example, the total resistance from the ILIM pin to GND).

8.3.5 Input Overvoltage

If the input voltage suddenly increases in potential (for example, due to a change in position of the equipment on the charging pad), the voltage-control loop inside the bq51010B becomes active, and prevents the output from going beyond $V_{OUT-REG}$. The receiver then starts sending back error packets to the transmitter every 30 ms until the input voltage comes back to the $V_{RECT-REG}$ target, and then maintains the error communication every 250 ms.

If the input voltage increases in potential beyond V_{OVP} , the IC switches off the LDO and communicates to the primary to bring the voltage back to $V_{RECT-REG}$. In addition, a proprietary voltage protection circuit is activated by means of C_{CLAMP1} and C_{CLAMP2} that protects the IC from voltages beyond the maximum rating of the IC (for example, 20 V).

8.3.6 Adapter Enable Functionality and EN1 or EN2 Control

Figure 32 is an example application that shows the bq51010B used as a wireless power receiver that can power multiplex between wired or wireless power for the down-system electronics. In the default operating mode pins EN1 and EN2 are low, which activates the adapter enable functionality. In this mode, if an adapter is not present the AD pin is low, and AD-EN pin is pulled to the higher of the OUT and AD pins so that the PMOS between OUT and AD is turned off. If an adapter is plugged in and the voltage at the AD pin goes above 3.6 V then wireless charging is disabled and the AD-EN pin is pulled approximately 4 V below the AD pin to connect AD to the secondary charger. The difference between AD and AD-EN is regulated to a maximum of 7V to ensure the V_{GS} of the external PMOS is protected.

The EN1 and EN2 pins include internal 200-k Ω pulldown resistors, so that if these pins are not connected bq51010B defaults to AD-EN control mode. However, these pins can be pulled high to enable other operating modes as described in Table 3.

Table 3. EN/EN2 Control

EN1	EN2	RESULT
0	0	Adapter control enabled. If adapter is present then secondary charger is powered by adapter, otherwise wireless charging is enabled when wireless power is available. Communication current limit is enabled.
0	1	Disables communication current limit.
1	0	AD-EN is pulled low, whether or not adapter voltage is present. This feature can be used, for example, in USB OTG applications.
1	1	Adapter and wireless charging are disabled, that is, power is never delivered by the OUT pin in this mode.

Table 4. Adapter Enable Functionality

EN1	EN2	WIRELESS POWER	WIRED POWER	OTG MODE	ADAPTIVE COMMUNICATION LIMIT	EPT
0	0	Enabled	Priority ⁽¹⁾	Disabled	Enabled	Not Sent to TX
0	1	Priority ⁽¹⁾	Enabled	Disabled	Disabled	Not Sent to TX
1	0	Disabled	Enabled	Enabled ⁽²⁾	—	No Response
1	1	Disabled	Disabled	Disabled	—	Termination

(1) If both wired and wireless power are present, wired power is given priority.

(2) Allows for a boost-back supply to be driven from the output terminal of the RX to the adapter port through the external back-to-back PMOS FET.

As described in Table 4, pulling EN2 high disables the adapter mode and only allows wireless charging. In this mode the adapter voltage is always blocked from the OUT pin. An application example where this mode is useful is when USB power is present at AD, but the USB is in suspend mode so that no power can be taken from the USB supply. Pulling EN1 high enables the off-chip PMOS regardless of the presence of a voltage. This function can be used in USB OTG mode to allow a charger connected to the OUT pin to power the AD pin. Finally, pulling both EN1 and EN2 high disables both wired and wireless charging.

NOTE

It is required to connect a back-to-back PMOS between AD and OUT so that voltage is blocked in both directions. Also, when AD mode is enabled no load can be pulled from the RECT pin as this could cause an internal device overvoltage in bq51010B.

8.3.7 End Power Transfer Packet (WPC Header 0x02)

The WPC allows for a special command for the receiver to terminate power transfer from the transmitter termed End Power Transfer (EPT) packet. Table 5 specifies the v1.1 reasons column and their corresponding data field value. The condition column corresponds to the methodology used by bq51010B to send equivalent message.

Table 5. End Power Transfer Packet

MESSAGE	VALUE	CONDITION
Unknown	0x00	$AD > 3.6\text{ V}$
Charge Complete	0x01	$TS/CTRL = 1$, or $EN1 = 1$, or $\langle EN1\ EN2 \rangle = \langle 11 \rangle$
Internal Fault	0x02	$T_J > 150^\circ\text{C}$ or $R_{LIM} < 100\ \Omega$
Over Temperature	0x03	$TS < V_{HOT}$, $TS > V_{COLD}$, or $TS/CTRL < 100\text{ mV}$
Over Voltage	0x04	Not Sent
Over Current	0x05	NOT USED
Battery Failure	0x06	Not Sent
Reconfigure	0x07	Not Sent
No Response	0x08	VRECT target doesn't converge

8.3.8 Status Outputs

The bq51010B has one status output, \overline{WPG} . This output is an open-drain NMOS device that is rated to 20 V. The open-drain FET connected to the \overline{WPG} pin is turned on whenever the output of the power supply is enabled. The output of the power supply is not enabled if the $V_{RECT-REG}$ does not converge at the no-load target voltage.

8.3.9 WPC Communication Scheme

The WPC communication uses a modulation technique termed *back-scatter modulation* where the receiver coil is dynamically loaded to provide amplitude modulation of the coil voltage and current of the transmitter. This scheme is possible due to the fundamental behavior between two loosely coupled inductors (for example, between the TX and RX coil). This type of modulation can be accomplished by switching in and out a resistor at the output of the rectifier, or by switching in and out a capacitor across the AC1/AC2 net. Figure 15 shows how to implement resistive modulation.

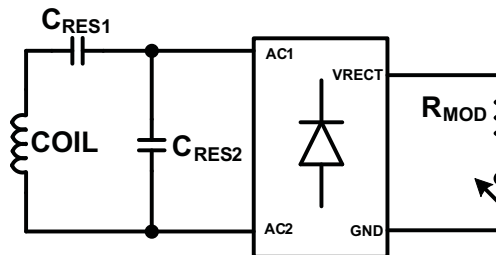
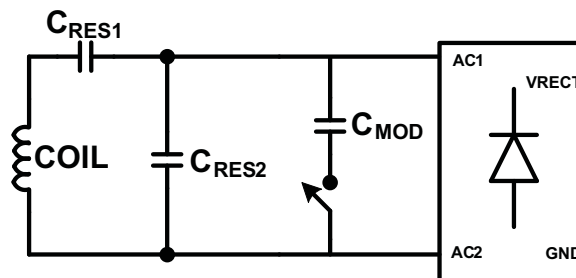

Figure 15. Resistive Modulation

Figure 16 shows how to implement capacitive modulation.

Figure 16. Capacitive Modulation

The amplitude change in TX coil voltage or current can be detected by the transmitters decoder. Figure 17 shows the resulting signal observed by the TX.

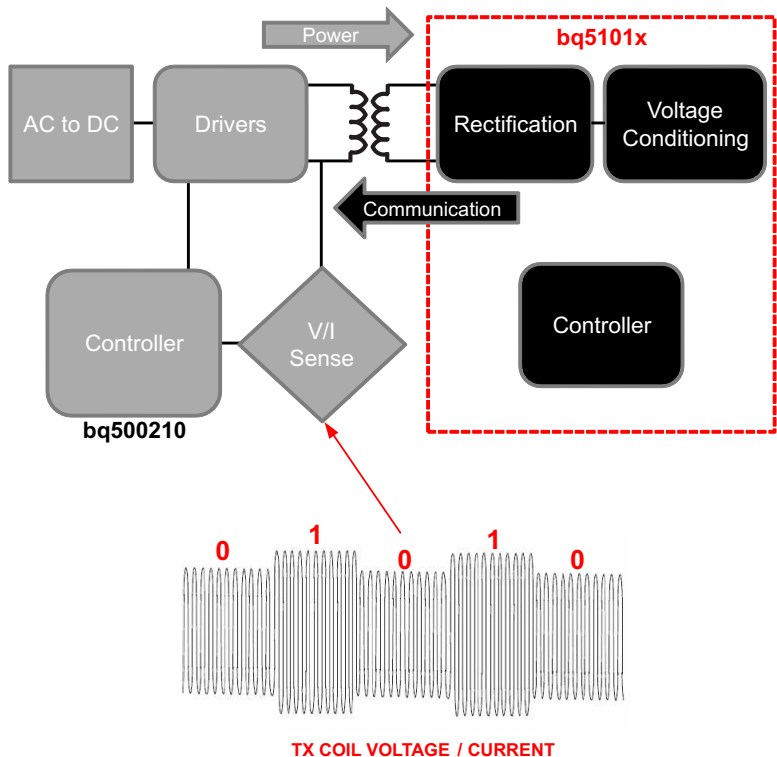

Figure 17. TX Coil Voltage and Current

The WPC protocol uses a differential biphas encoding scheme to modulate the data bits onto the TX coil voltage and current. Each data bit is aligned at a full period of 0.5 ms (t_{CLK}) or 2 kHz. An encoded ONE results in two transitions during the bit period and an encoded ZERO results in a single transition. See Figure 18 for an example of the differential biphas encoding.

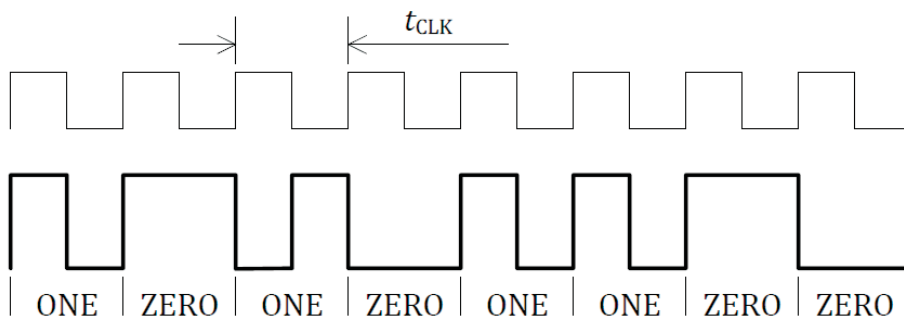

Figure 18. Differential Biphas Encoding Scheme (WPC volume 1: Low Power, Part 1 Interface Definition)

The bits are sent LSB first and use an 11-bit asynchronous serial format for each portion of the packet. This includes one start bit, n-data bytes, a parity bit, and a single stop bit. The start bit is always ZERO and the parity bit is odd. The stop bit is always ONE. Figure 19 shows the details of the asynchronous serial format.

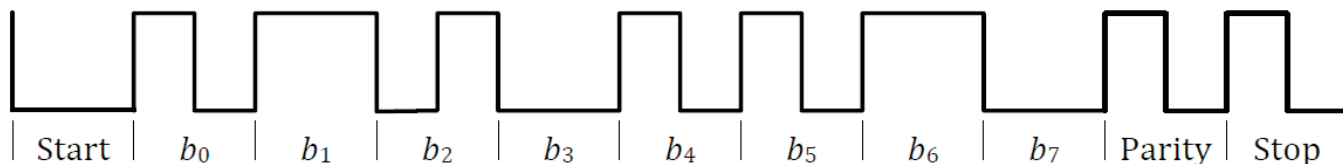

Figure 19. Asynchronous Serial Formatting (WPC volume 1: Low Power, Part 1 Interface Definition)

Each packet format is organized as shown in [Figure 20](#).

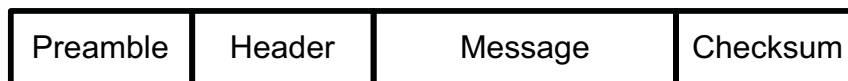

Figure 20. Packet Format (WPC volume 1: Low Power, Part 1 Interface Definition)

8.3.10 Communication Modulator

The bq51010B provides two identical, integrated communication FETs which are connected to the pins COM1 and COM2. These FETs are used for modulating the secondary load current which allows bq51010B to communicate error control and configuration information to the transmitter. [Figure 21](#) below shows how the COMM pins can be used for resistive load modulation. Each COMM pin can handle at most a 24-Ω communication resistor. Therefore, if a COMM resistor between 12 Ω and 24 Ω is required COM1 and COM2 pins must be connected in parallel. bq51010B does not support a COMM resistor less than 12 Ω.

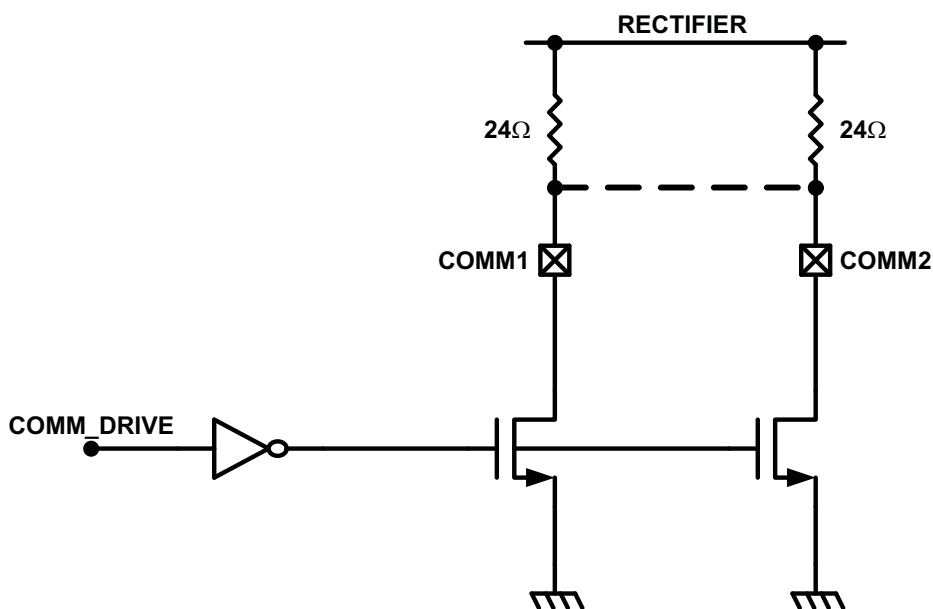

Figure 21. Resistive Load Modulation

In addition to resistive load modulation, the bq51010B is also capable of capacitive load modulation as shown in [Figure 22](#) below. In this case, a capacitor is connected from COM1 to AC1 and from COM2 to AC2. When the COMM switches are closed there is effectively a 22-nF capacitor connected between AC1 and AC2. Connecting a capacitor in between AC1 and AC2 modulates the impedance seen by the coil, which is reflected in the primary as a change in current.

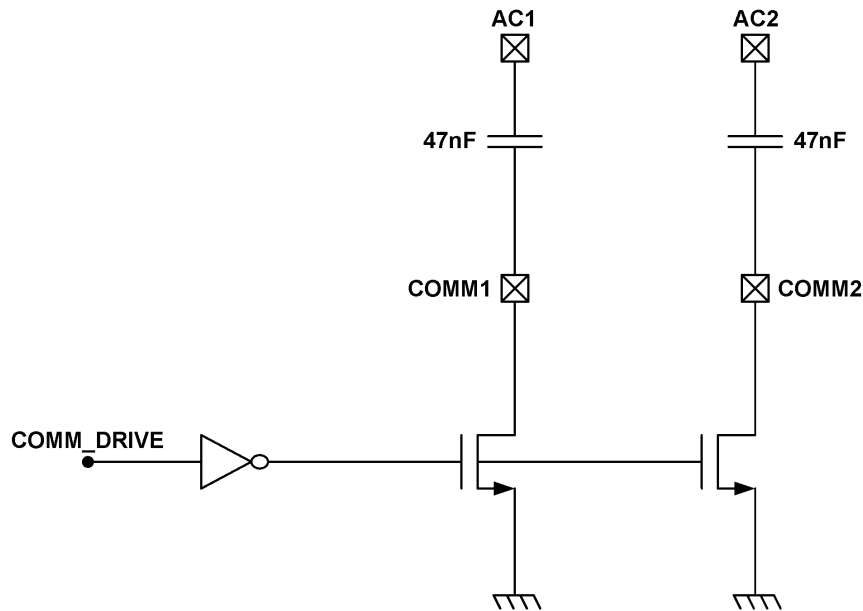

Figure 22. Capacitive Load Modulation

8.3.11 Adaptive Communication Limit

The Qi communication channel is established through backscatter modulation as described in the previous sections. This type of modulation takes advantage of the loosely coupled inductor relationship between the RX and TX coil. Essentially the switching in-and-out of the communication capacitor or resistor adds a transient load to the RX coil to modulate the TX coil voltage or current waveform (amplitude modulation). The consequence of this technique is that a load transient (load current noise) from the mobile device has the same signature. To provide noise immunity to the communication channel, the output load transients must be isolated from the RX coil. The proprietary feature *adaptive communication limit* achieves this by dynamically adjusting the current limit of the regulator. When the regulator is put in current limit, any load transients is offloaded to the battery in the system.

Note that this requires the battery charger IC to have input voltage regulation (weak adapter mode). The output of the RX appears as a weak supply if a transient occurs above the current limit of the regulator.

The adaptive communication limit feature has two current limit modes listed in [Table 6](#).

Table 6. Adaptive Communication Limit

I_{OUT}	COMMUNICATION CURRENT LIMIT
< 300 mA	Fixed 400 mA
> 300 mA	$I_{OUT} + 50$ mA

8.3.12 Synchronous Rectification

The bq51010B provides an integrated, self-driven synchronous rectifier that enables high-efficiency AC to DC power conversion. The rectifier consists of an all NMOS H-Bridge driver where the backgates of the diodes are configured to be the rectifier when the synchronous rectifier is disabled. During the initial start-up of the WPC system the synchronous rectifier is not enabled. At this operating point, the DC rectifier voltage is provided by the diode rectifier. Once V_{RECT} is greater than $UVLO$, half-synchronous mode is enabled until the load current surpasses 120 mA. Above 120 mA, the full synchronous rectifier stays enabled until the load current drops back below 100 mA where half-synchronous mode is enabled instead.

8.3.13 Temperature Sense Resistor Network (TS)

bq51010B includes a ratiometric external temperature sense function. The temperature sense function has two ratiometric thresholds which represent a hot and cold condition. TI recommends an external temperature sensor to provide safe operating conditions for the receiver product. This pin is best used for monitoring the surface that can be exposed to the end user (for example, place the NTC resistor closest to the user).

Figure 23 allows for any NTC resistor to be used with the given V_{HOT} and V_{COLD} thresholds.



Figure 23. NTC Circuit Used for Safe Operation of the Wireless Receiver Power Supply

The resistors R_1 and R_3 can be solved by resolving the system of equations at the desired temperature thresholds (see Equation 2 and Equation 3).

$$\%V_{COLD} = \frac{\left(\frac{R_3 (R_{NTC|TCOLD} + R_1)}{R_3 + (R_{NTC|TCOLD} + R_1)} \right)}{\left(\frac{R_3 (R_{NTC|TCOLD} + R_1)}{R_3 + (R_{NTC|TCOLD} + R_1)} \right) + R_2} \times 100$$

$$\%V_{HOT} = \frac{\left(\frac{R_3 (R_{NTC|THOT} + R_1)}{R_3 + (R_{NTC|THOT} + R_1)} \right)}{\left(\frac{R_3 (R_{NTC|THOT} + R_1)}{R_3 + (R_{NTC|THOT} + R_1)} \right) + R_2} \times 100 \quad (2)$$

$$R_{NTC|TCOLD} = R_0 e^{\beta \left(\frac{1}{TCOLD} - \frac{1}{T_0} \right)}$$

$$R_{NTC|THOT} = R_0 e^{\beta \left(\frac{1}{THOT} - \frac{1}{T_0} \right)}$$

where

- T_{COLD} and T_{HOT} are the desired temperature thresholds in degrees Kelvin
- R_0 is the nominal resistance
- β is the temperature coefficient of the NTC resistor
- R_0 is fixed at 20 kΩ

(3)

An example solution is provided:

- $R_1 = 4.23 \text{ k}\Omega$
- $R_3 = 66.8 \text{ k}\Omega$

Where the chosen parameters are:

- $\%V_{\text{HOT}} = 19.6\%$
- $\%V_{\text{COLD}} = 58.7\%$
- $T_{\text{COLD}} = -10^\circ\text{C}$
- $T_{\text{HOT}} = 100^\circ\text{C}$
- $\beta = 3380$
- $R_0 = 10 \text{ k}\Omega$

Figure 24 shows the plot of the percent V_{TSB} vs temperature.

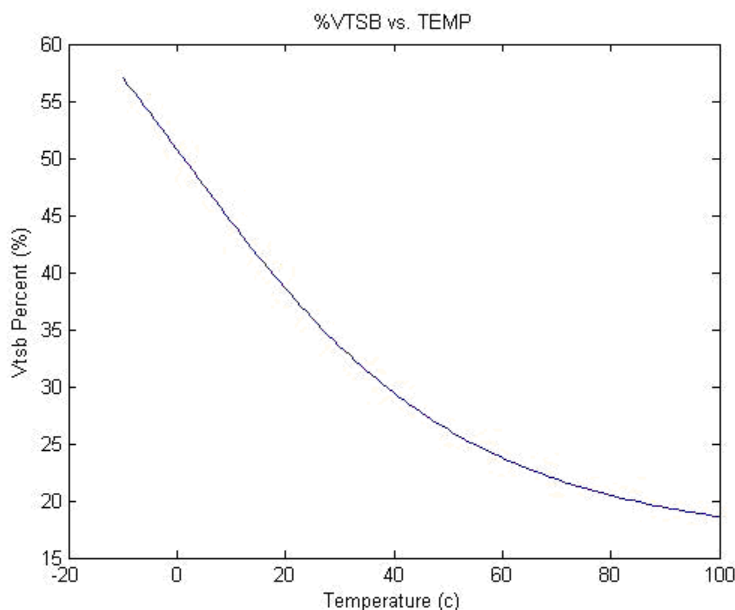
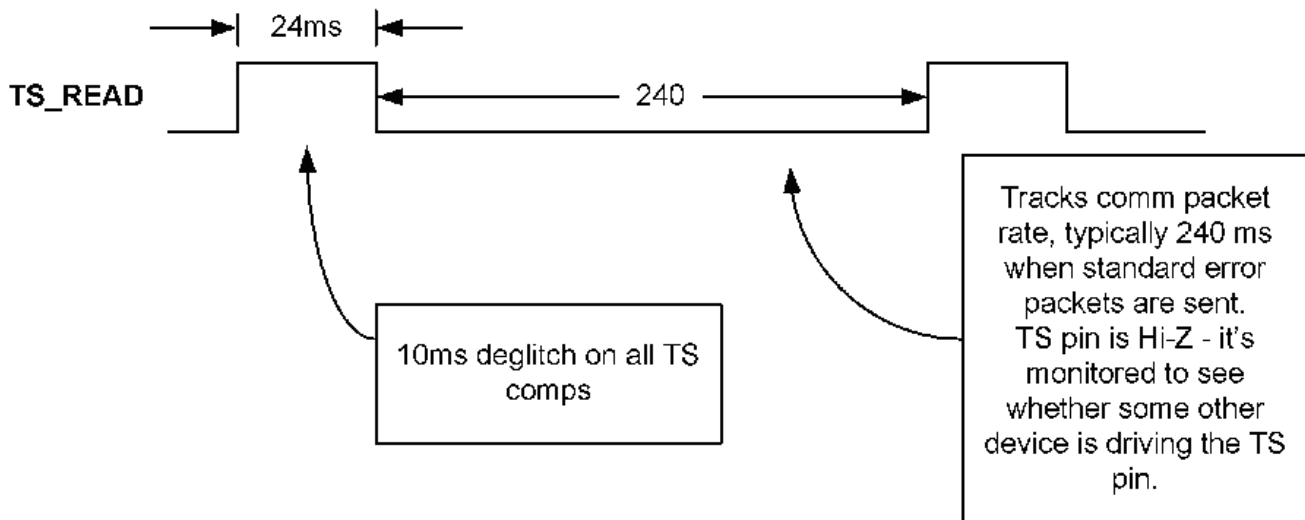

Figure 24. Example Solution for an NTC resistor with $R_0 = 10 \text{ k}\Omega$ and $\beta = 4500$

Figure 25 illustrates the periodic biasing scheme used for measuring the TS state. The TS_READ signal enables the TS bias voltage for 24 ms. During this period the TS comparators are read (each comparator has a 10 ms deglitch) and appropriate action is taken based on the temperature measurement. After this 24 ms period has elapsed, the TS_READ signal goes low, which causes the TS-Bias pin to become high impedance. During the next 35 ms (priority packet period) or 235 ms (standard packet period), the TS voltage is monitored and compared to 100 mV. If the TS voltage is greater than 100 mV then a secondary device is driving the TS or CTRL pin and a CTRL = 1 is detected.

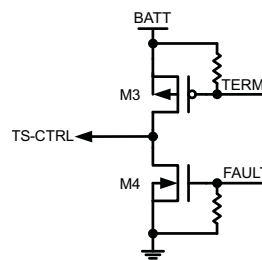

Figure 25. Timing Diagram for TS Detection Circuit

8.3.14 3-State Driver Recommendations For the TS-CTRL Pin

The TS-CTRL pin offers three functions with one 3-state driver interface:

1. NTC temperature monitoring,
2. Fault indication,
3. Charge done indication

A 3-state driver can be implemented with the circuit in [Figure 26](#) and the use of two GPIO connections.

Figure 26. 3-state Driver for TS-CTRL

Note that the signals *TERM* and *FAULT* are given by two GPIOs. The truth table for this circuit is found in [Table 7](#).

Table 7. Truth Table

TERM	FAULT	F (RESULT)
1	0	Z (Normal mode)
0	0	Charge complete
1	1	System fault

The default setting is $TERM = 1$ and $FAULT = 0$. In this condition, the TS-CTRL net is high impedance (hi-z); therefore, the NTC is function is allowed to operate. When the TS-CTRL pin is pulled to GND by setting $FAULT = 1$, the RX is shutdown with the indication of a fault. When the TS-CTRL pin is pulled to the battery by setting $TERM = 1$, the RX is shutdown with the indication of a charge complete condition. Therefore, the host controller can indicate whether the RX is system is turning off due to a fault or due to a charge complete condition.

8.3.15 Thermal Protection

The bq51010B includes a thermal shutdown protection. If the die temperature reaches $T_J(\text{OFF})$, the LDO is shut off to prevent any further power dissipation. In this case bq51010B sends an EPT message of internal fault (0x02).

8.3.16 WPC 1.1 Compliance – Foreign Object Detection

The bq51010B is a WPC 1.1 compatible device. To enable a power transmitter to monitor the power loss across the interface as one of the possible methods to limit the temperature rise of foreign objects, the bq51010B reports its received power to the power transmitter. The received power equals the power that is available from the output of the power receiver plus any power that is lost in producing that output power (the power loss in the secondary coil and series resonant capacitor, the power loss in the shielding of the power receiver, the power loss in the rectifier). In WPC1.1 specification, foreign object detection (FOD) is enforced. This means the bq51010B sends received power information with known accuracy to the transmitter.

WPC 1.1 defines received power as “the average amount of power that the power receiver receives through its interface surface, in the time window indicated in the configuration packet”.

To receive certification as a WPC 1.1 receiver, the Device Under Test (DUT) is tested on a reference transmitter whose transmitted power is calibrated, the receiver must send a received power such that [Equation 4](#).

$$0 < (\text{TX PWR})_{\text{REF}} - (\text{RX PWR out})_{\text{DUT}} < -250 \text{ mW} \quad (4)$$

This 250-mW bias ensures that system remains interoperable.

WPC 1.1 transmitter is tested to see if they can detect reference foreign objects with a reference receiver.

WPC 1.1 specification allows much more accurate sensing of foreign objects.

8.4 Device Functional Modes

The operational modes of the bq51010B are described in [Feature Description](#). The bq51010B has several functional modes. Start-up refers to the initial power transfer and communication between the receiver (bq51010B circuit) and the transmitter. Power transfer refers to any time that the TX and RX are communicating and power is being delivered from the TX to the RX. Power transfer termination occurs when the RX is removed from the TX, power is removed from the TX or the RX requests power transfer termination.

Typical Applications (continued)

The bq51010B identifies and authenticates itself to the primary using the COMM pins by switching on and off the COMM FETs and hence switching in and out C_{COMM} . If the authentication is successful, the transmitter remains powered on. The bq51010B measures the voltage at the RECT pin, calculates the difference between the actual voltage and the desired voltage $V_{RECT-REG}$, (threshold 1 at no load) and sends back error packets to the primary. Dynamic V_{RECT} thresholds are shown in [Electrical Characteristics](#). This process goes on until the input voltage settles at $V_{RECT-REG}$. During a load transient, the dynamic rectifier algorithm sets the targets specified by $V_{RECT-REG}$ thresholds 1, 2, 3, and 4. This algorithm is termed dynamic dynamic rectifier control and is used to enhance the transient response of the power supply.

During power up, the LDO is held off until the $V_{RECT-REG}$ threshold 1 converges. The voltage control loop ensures that the output voltage is maintained at $V_{OUT-REG}$ to power the system. The bq51010B meanwhile continues to monitor the input voltage and maintains sending error packets to the primary every 250 ms. If a large overshoot occurs, the feedback to the primary speeds up to every 32 ms to converge on an operating point in less time.

9.2.1.2.2 Series and Parallel Resonant Capacitor Selection

Shown in [Figure 27](#), the capacitors C1 (series) and C2 (parallel) make up the dual resonant circuit with the receiver coil. These two capacitors must be sized correctly per the WPC v1.1 specification. [Figure 28](#) illustrates the equivalent circuit of the dual resonant circuit.

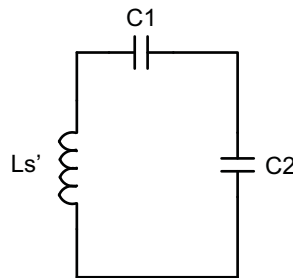

Figure 28. Dual Resonant Circuit With the Receiver Coil

Section 4.2 (Power Receiver Design Requirements) in Part 1 of the WPC v1.1 specification highlights in detail the sizing requirements. To summarize, the receiver designer is required take inductance measurements with a fixed test fixture. [Figure 29](#) shows the test fixture.

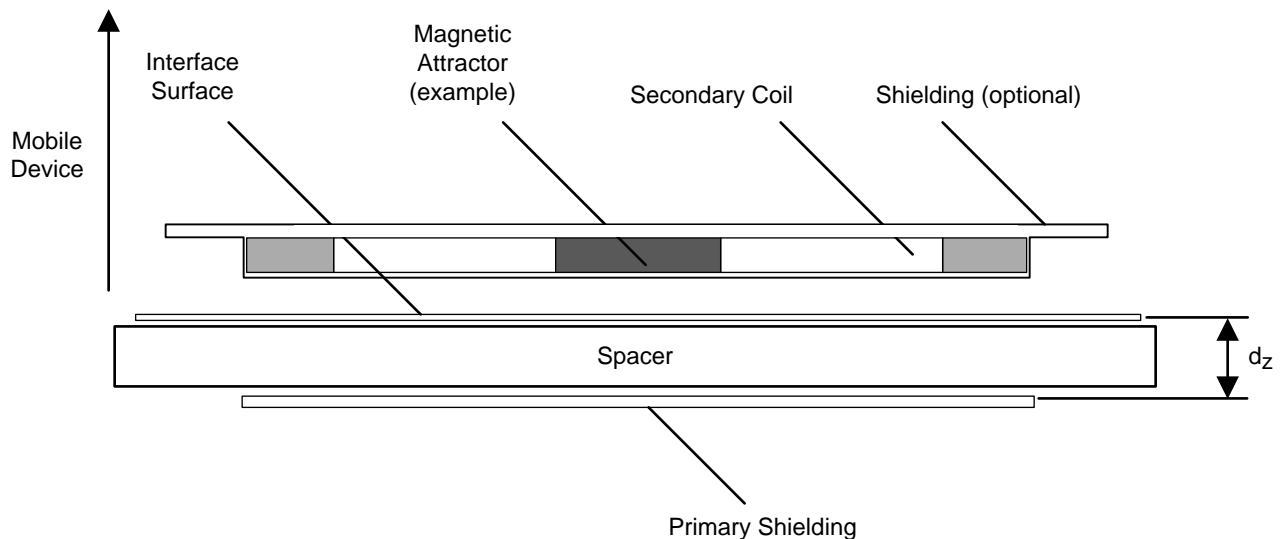

Figure 29. WPC v1.1 Receiver Coil Test Fixture for the Inductance Measurement $L_{s'}$ (Copied from System Description Wireless Power Transfer, Volume 1: Low Power, Part 1 Interface Definition, Version 1.1)

Typical Applications (continued)

The primary shield is to be 50 mm × 50 mm × 1 mm of Ferrite material PC44 from TDK Corp. The gap d_z is to be 3.4 mm. The receiver coil, as it is placed in the final system (for example, the back cover and battery must be included if the system calls for this), is to be placed on top of this surface and the inductance is to be measured at 1-V RMS and a frequency of 100 kHz. This measurement is termed L_s' . The same measurement is to be repeated without the test fixture shown in [Figure 8](#). This measurement is termed L_s or the free-space inductance. Each capacitor can then be calculated using [Equation 5](#).

$$C_1 = \left[(f_S \times 2\pi)^2 \times L_S' \right]^{-1}$$

$$C_2 = \left[(f_D \times 2\pi)^2 \times L_S - \frac{1}{C_1} \right]^{-1}$$

where

- f_S is 100 kHz +5/-10%
 - f_D is 1 MHz ±10%
- (5)

C_1 must be chosen first prior to calculating C_2 .

The quality factor must be greater than 77 and can be determined by [Equation 6](#).

$$Q = \frac{2\pi \cdot f_D \cdot L_S}{R}$$

where

- R is the DC resistance of the receiver coil
- (6)

All other constants are defined above.

9.2.1.2.3 COMM, CLAMP, and BOOT Capacitors

For most applications, the COMM, CLAMP, and BOOT capacitance values is chosen to match the bq51010B.

The BOOT capacitors are used to allow the internal rectifier FETs to turn on and off properly. These capacitors are from AC1 to BOOT1 and from AC2 to BOOT2 and must have a minimum 25-V rating. A 10-nF capacitor with a 25-V rating is chosen.

The CLAMP capacitors are used to aid in the clamping process to protect against overvoltage. These capacitors are from AC1 to CLAMP1 and from AC2 to CLAMP2 and must have a minimum 25-V rating. A 0.47- μ F capacitor with a 25-V rating is chosen.

The COMM capacitors are used to facilitate the communication from the RX to the TX. This selection can vary a bit more than the BOOT and CLAMP capacitors. In general, TI recommends a 22-nF capacitor. Based on the results of testing of the communication robustness in the final solution, a change to a 47-nF capacitor may be in order. The larger the capacitor the larger the deviation is on the coil which sends a stronger signal to the TX. This also decreases the efficiency somewhat. In this case, a 22-nF capacitor with a 25-V rating is chosen.

9.2.1.2.4 Control Pins and \overline{WPG}

This section discusses the pins that control the functions of the bq51010B (AD, $\overline{AD_EN}$, EN1, EN2, and TS or CTRL).

This solution uses wireless power exclusively. The AD pin is tied low to disable wired power interaction. The output pin $\overline{AD_EN}$ is left floating.

EN1 and EN2 are tied to the system controller GPIO pins. This allows the system to control the wireless power transfer. Normal operation leaves EN1 and EN2 low or floating (GPIO low or high impedance). EN1 and EN2 have internal pulldown resistors. With both EN1 and EN2 low, wireless power is enabled and power can be transferred whenever the RX is on a suitable TX. The RX system controller can terminate power transfer and send an EPT 0x01 (Charge Complete) by setting EN1=EN2=1. The TX terminates power when the EPT 0x01 is received. The TX continues to test for power transfer, but not engage until the RX requests power. For example, if the TX is the bq500212A, the TX sends digital pings approximately once per 5 seconds. During each ping, the

Typical Applications (continued)

bq51010B resends the EPT 0x01. Between the pings, the bq500212A goes into low power *sleep* mode reducing power consumption. When the RX system controller determines it is time to resume power transfer (for example, the battery voltage is below its recharge threshold) the controller simply returns EN1 and EN2 to low (or float) states. The next ping of the bq500212A powers the bq51010B which now communicates that it is time to transfer power. The TX and RX communication resumes and power transfer is reinitiated.

The TS or CTRL pin is used as a temperature sensor (with the NTC) and maintain the ability to terminate power transfer through the system controller. In this case, the GPIO is in high impedance for normal NTC (Temperature Sense) control.

The \overline{WPG} pin is used to indicate power transfer. A 2.1-V forward bias LED is used for D₁ with a current limiting 1.5-k Ω series resistor. The LED and resistor are tied from OUT to PGND and D₁ lights during power transfer.

9.2.1.2.5 Current Limit and FOD

The current limit and foreign object detection functions are related. The current limit is set by $R_1 + R_{FOD}$. R_{FOD} and R_{os} are determined by FOD calibration. Default values of 20 k Ω for R_{os} (to RECT, R_{os2} . R_{os1} is not populated). 200 Ω for R_{FOD} are used. The final values required to be determined based on the FOD calibration. The tool for FOD calibration can be found on the bq51010B web folder under *Tools & Software*. Good practice is to set the layout with 2 resistors for R_{os} and 2 for R_{FOD} to allow for precise values once the calibration is complete.

After setting R_{FOD} , R_1 can be calculated based on the desired current limit. The maximum current for this solution under normal operating conditions (I_{MAX}) is 714 mA. Using Equation 1 to calculate the maximum current yields a value of 367 Ω for R_{LIM} . With R_{FOD} set to 200 Ω the remaining resistance for R_1 is 167 Ω . Choose the closest standard resistor of 165 Ω . This also sets the hardware current limit to 856 mA to allow for temporary current surges without system performance concerns.

9.2.1.2.6 RECT and OUT Capacitance

RECT capacitance is used to smooth the AC to DC conversion and to prevent minor current transients from passing to OUT. For this 714-mA I_{MAX} , select two 10- μ F capacitors and one 0.1- μ F capacitor. These must be rated to 16 V.

OUT capacitance is used to reduce any ripple from minor load transients. For this solution, a single 10- μ F capacitor and a single 0.1- μ F capacitor are used.

9.2.1.3 Application Curves

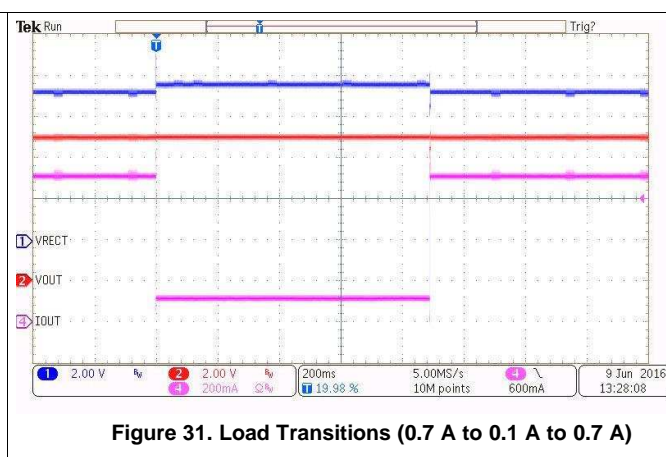
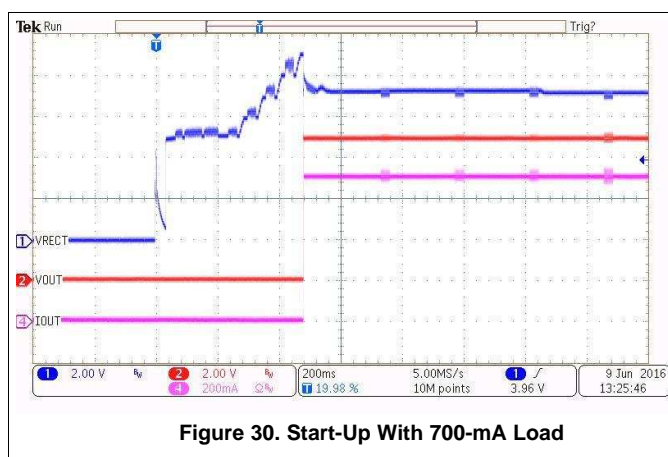

Typical Applications (continued)

Figure 34 shows the transition to wireless power when the AD voltage is removed. Note that after wired power is removed, the next ping from bq500212A energizes the bq51010B. Once the rectifier voltage is stable the output turns on.

Figure 35 shows a system placed onto the transmitter with AD already powered. The TX sends a ping which the RX responds to and informs the TX that no power is required. The ping continues with the timing based on the TX used.

Figure 36 shows the AD added when the RX is not on a TX. This indicates normal start-up without requirement of the TX.

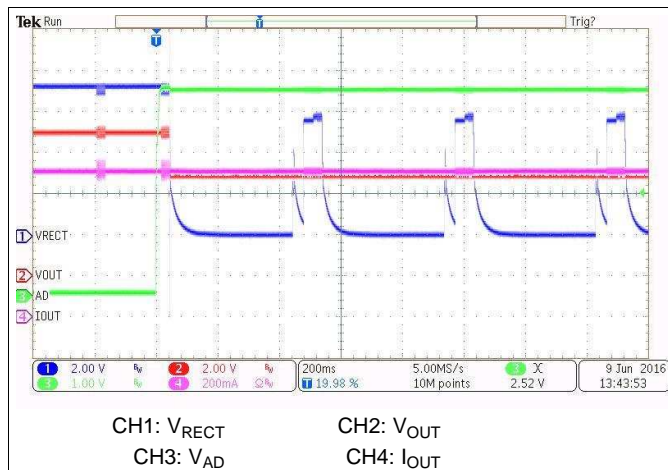

Figure 33. Transition Between Wireless Power and Wired Power (EN1 = EN2 = LOW)

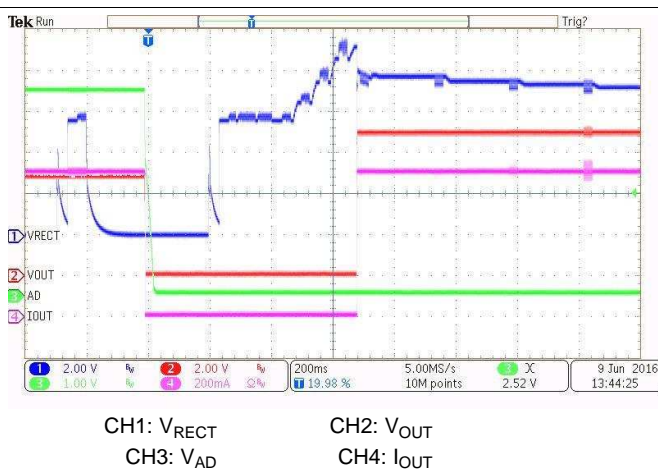

Figure 34. Transition Between Wired Power and Wireless Power (EN1 = EN2 = LOW)

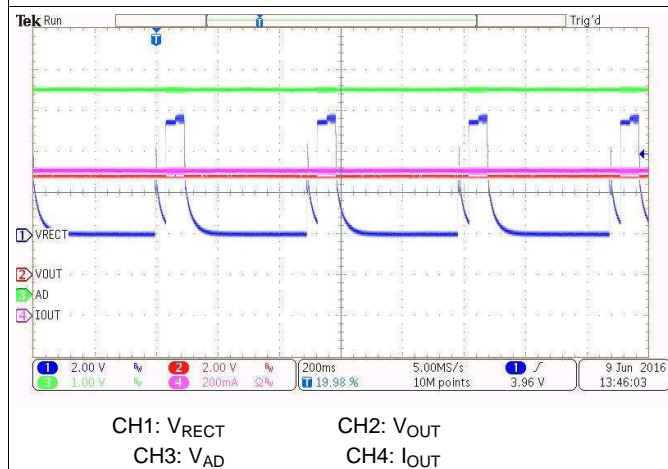

Figure 35. Wireless Power Start-Up With V_{AD} = 5 V (EN1 = EN2 = LOW)

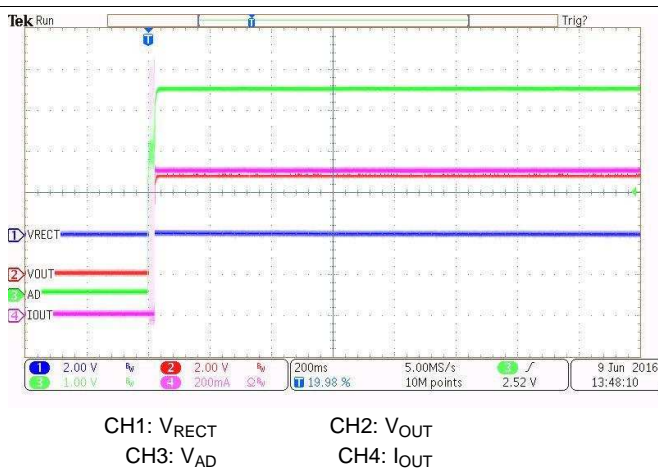

Figure 36. AD Power Start-Up With No Transmitter (EN1 = EN2 = LOW)

Typical Applications (continued)

9.2.3 Wireless and Direct Charging of a Li-Ion Battery at 800 mA

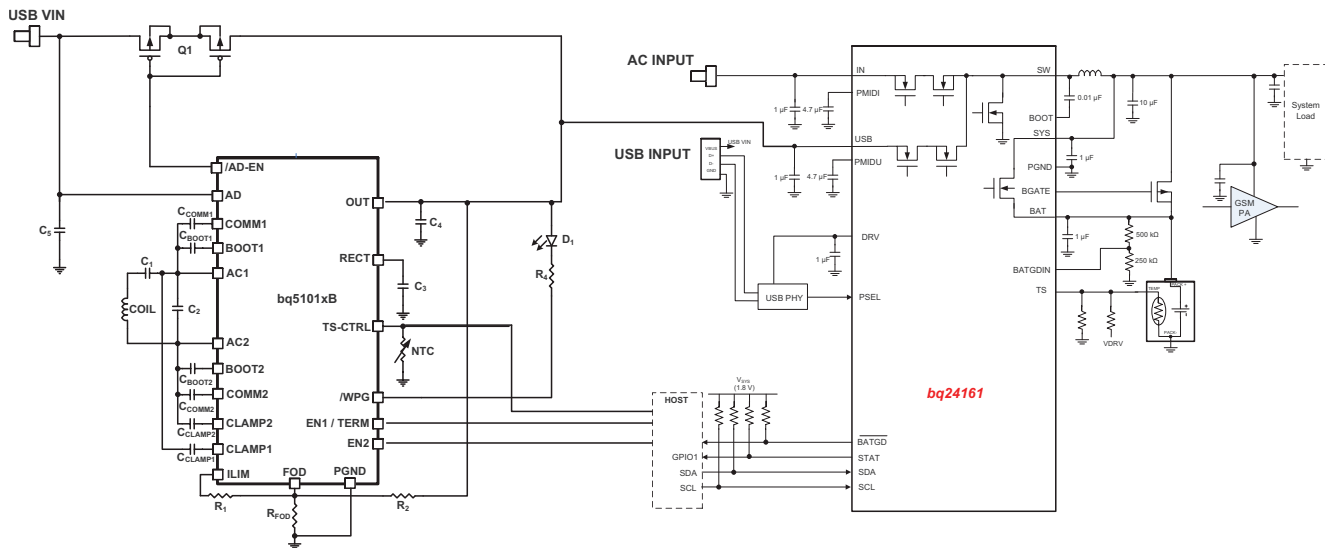

Figure 37. bq51010B Used as a Wireless Power Supply With Adapter Multiplexing on a Two Input Charger

9.2.3.1 Design Requirements

The goal of this design is to charge a 3.7-V Li-Ion battery at 800 mA either wirelessly or with a direct USB wired input. This design will use the bq51010B wireless power supply and the bq24161 single-cell Li-Ion battery charger. A low resistance path has to be created between the output of bq51010B and the input of bq24161.

9.2.3.2 Detailed Design Procedure

The basic components used in [Figure 27](#) and [Figure 32](#) are reused in [Figure 37](#), as well. The bq51010B OUT pin is tied to the output of Q1 and directly to the IN pin of the bq24161. No other changes to the bq51010B circuitry are required. Consult the bq24161 data sheet [bq2416xx 2.5A, Dual-Input, Single-Cell Switched-Mode Li-Ion Battery Charger with Power Path Management and I²C Interface](#) for selecting its correct components.

10 Power Supply Recommendations

The bq51010B requires a Qi-compatible transmitter as its power source.

11 Layout

11.1 Layout Guidelines

- Keep the trace resistance as low as possible on AC1, AC2, and BAT.
- Detection and resonant capacitors must be as close to the device as possible.
- COMM, CLAMP, and BOOT capacitors must be placed as close to the device as possible.
- Via interconnect on PGND net is critical for appropriate signal integrity and proper thermal performance.
- High-frequency bypass capacitors must be placed close to RECT and OUT pins.
- ILIM and FOD resistors are important signal paths and the loops in those paths to PGND must be minimized.

Signal and sensing traces are the most sensitive to noise; the sensing signal amplitudes are usually measured in mV, which is comparable to the noise amplitude. Make sure that these traces are not being interfered by the noisy and power traces. AC1, AC2, BOOT1, BOOT2, COMM1, and COMM2 are the main source of noise in the board. These traces must be shielded from other components in the board. It is usually preferred to have a ground copper area placed underneath these traces to provide additional shielding. Also, make sure they do not interfere with the signal and sensing traces. The PCB must have a ground plane (return) connected directly to the return of all components through vias (two vias per capacitor for power-stage capacitors, one via per capacitor for small-signal components).

For a 1-A fast charge current application, the current rating for each net is as follows:

- AC1 = AC2 = 1.2 A
- OUT = 1 A
- RECT = 100 mA (RMS)
- COMMx = 300 mA
- CLAMPx = 500 mA
- All others can be rated for 10 mA or less

11.2 Layout Example

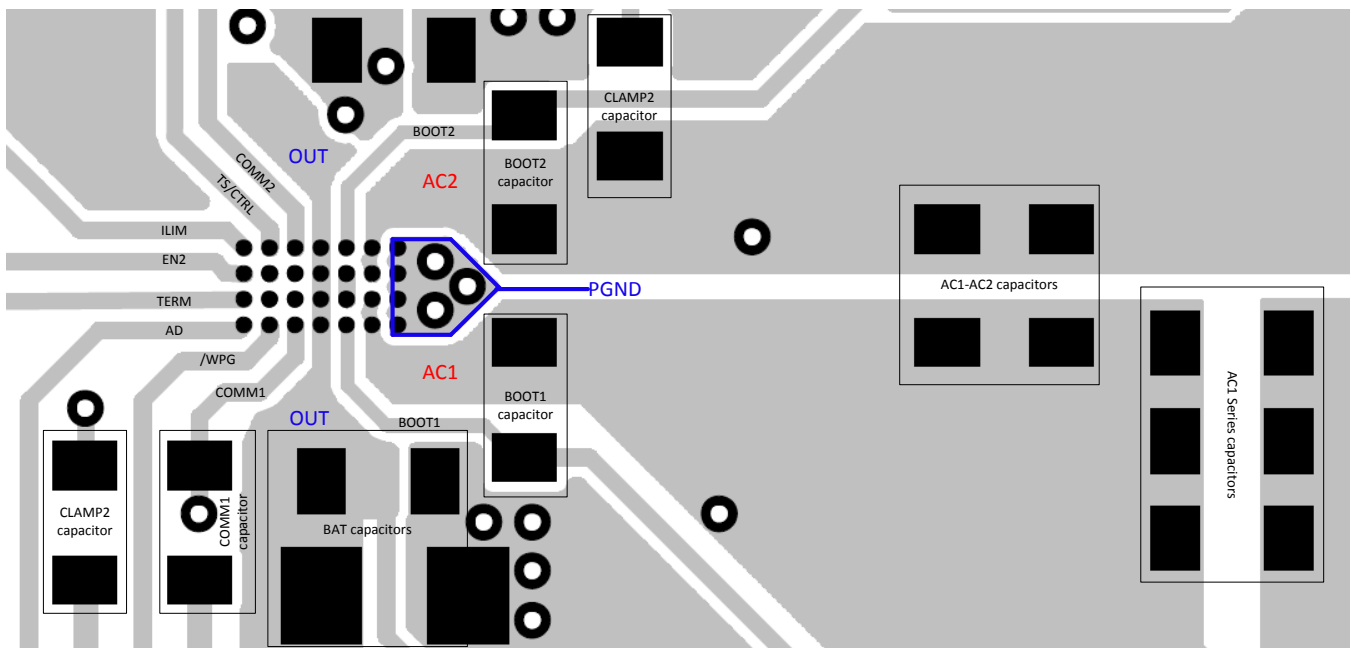

Figure 38. Layout Schematic

12 器件和文档支持

12.1 器件支持

12.1.1 Third-Party Products Disclaimer

TI'S PUBLICATION OF INFORMATION REGARDING THIRD-PARTY PRODUCTS OR SERVICES DOES NOT CONSTITUTE AN ENDORSEMENT REGARDING THE SUITABILITY OF SUCH PRODUCTS OR SERVICES OR A WARRANTY, REPRESENTATION OR ENDORSEMENT OF SUCH PRODUCTS OR SERVICES, EITHER ALONE OR IN COMBINATION WITH ANY TI PRODUCT OR SERVICE.

12.2 文档支持

12.2.1 相关文档

相关文档如下：

- 应用手册 《[针对无线电源接收器进行测试和故障排除](#)》
- EVM 用户指南 《[bq51010BEVM-764 评估模块](#)》
- 《[bq2416xx 具有电源路径管理功能和 I²C 接口的 2.5A、双输入、单节开关模式锂离子电池充电器](#)》

12.3 接收文档更新通知

如需接收文档更新通知，请访问 www.ti.com.cn 网站上的器件产品文件夹。点击右上角的提醒我 (Alert me) 注册后，即可每周定期收到已更改的产品信息。有关更改的详细信息，请查阅已修订文档中包含的修订历史记录。

12.4 社区资源

The following links connect to TI community resources. Linked contents are provided "AS IS" by the respective contributors. They do not constitute TI specifications and do not necessarily reflect TI's views; see TI's [Terms of Use](#).

TI E2E™ Online Community *TI's Engineer-to-Engineer (E2E) Community*. Created to foster collaboration among engineers. At e2e.ti.com, you can ask questions, share knowledge, explore ideas and help solve problems with fellow engineers.

Design Support *TI's Design Support* Quickly find helpful E2E forums along with design support tools and contact information for technical support.

12.5 商标

E2E is a trademark of Texas Instruments.
All other trademarks are the property of their respective owners.

12.6 静电放电警告



这些装置包含有限的内置 ESD 保护。存储或装卸时，应将导线一起截短或将装置放置于导电泡棉中，以防止 MOS 门极遭受静电损伤。

12.7 Glossary

SLYZ022 — *TI Glossary*.

This glossary lists and explains terms, acronyms, and definitions.

13 机械、封装和可订购信息

以下页中包括机械、封装和可订购信息。这些信息是针对指定器件可提供的最新数据。这些数据会在无通知且不对本文档进行修订的情况下发生改变。欲获得该数据表的浏览器版本，请查阅左侧的导航栏。

PACKAGING INFORMATION

Orderable Device	Status (1)	Package Type	Package Drawing	Pins	Package Qty	Eco Plan (2)	Lead finish/ Ball material (6)	MSL Peak Temp (3)	Op Temp (°C)	Device Marking (4/5)	Samples
BQ51010BYFPR	ACTIVE	DSBGA	YFP	28	3000	RoHS & Green	SNAGCU	Level-1-260C-UNLIM	-40 to 85	BQ51010B	Samples
BQ51010BYFPT	NRND	DSBGA	YFP	28	250	RoHS & Green	SNAGCU	Level-1-260C-UNLIM	-40 to 85	BQ51010B	

(1) The marketing status values are defined as follows:

ACTIVE: Product device recommended for new designs.

LIFEBUY: TI has announced that the device will be discontinued, and a lifetime-buy period is in effect.

NRND: Not recommended for new designs. Device is in production to support existing customers, but TI does not recommend using this part in a new design.

PREVIEW: Device has been announced but is not in production. Samples may or may not be available.

OBSOLETE: TI has discontinued the production of the device.

(2) **RoHS:** TI defines "RoHS" to mean semiconductor products that are compliant with the current EU RoHS requirements for all 10 RoHS substances, including the requirement that RoHS substance do not exceed 0.1% by weight in homogeneous materials. Where designed to be soldered at high temperatures, "RoHS" products are suitable for use in specified lead-free processes. TI may reference these types of products as "Pb-Free".

RoHS Exempt: TI defines "RoHS Exempt" to mean products that contain lead but are compliant with EU RoHS pursuant to a specific EU RoHS exemption.

Green: TI defines "Green" to mean the content of Chlorine (Cl) and Bromine (Br) based flame retardants meet JS709B low halogen requirements of <=1000ppm threshold. Antimony trioxide based flame retardants must also meet the <=1000ppm threshold requirement.

(3) MSL, Peak Temp. - The Moisture Sensitivity Level rating according to the JEDEC industry standard classifications, and peak solder temperature.

(4) There may be additional marking, which relates to the logo, the lot trace code information, or the environmental category on the device.

(5) Multiple Device Markings will be inside parentheses. Only one Device Marking contained in parentheses and separated by a "~" will appear on a device. If a line is indented then it is a continuation of the previous line and the two combined represent the entire Device Marking for that device.

(6) Lead finish/Ball material - Orderable Devices may have multiple material finish options. Finish options are separated by a vertical ruled line. Lead finish/Ball material values may wrap to two lines if the finish value exceeds the maximum column width.

Important Information and Disclaimer: The information provided on this page represents TI's knowledge and belief as of the date that it is provided. TI bases its knowledge and belief on information provided by third parties, and makes no representation or warranty as to the accuracy of such information. Efforts are underway to better integrate information from third parties. TI has taken and continues to take reasonable steps to provide representative and accurate information but may not have conducted destructive testing or chemical analysis on incoming materials and chemicals. TI and TI suppliers consider certain information to be proprietary, and thus CAS numbers and other limited information may not be available for release.

In no event shall TI's liability arising out of such information exceed the total purchase price of the TI part(s) at issue in this document sold by TI to Customer on an annual basis.

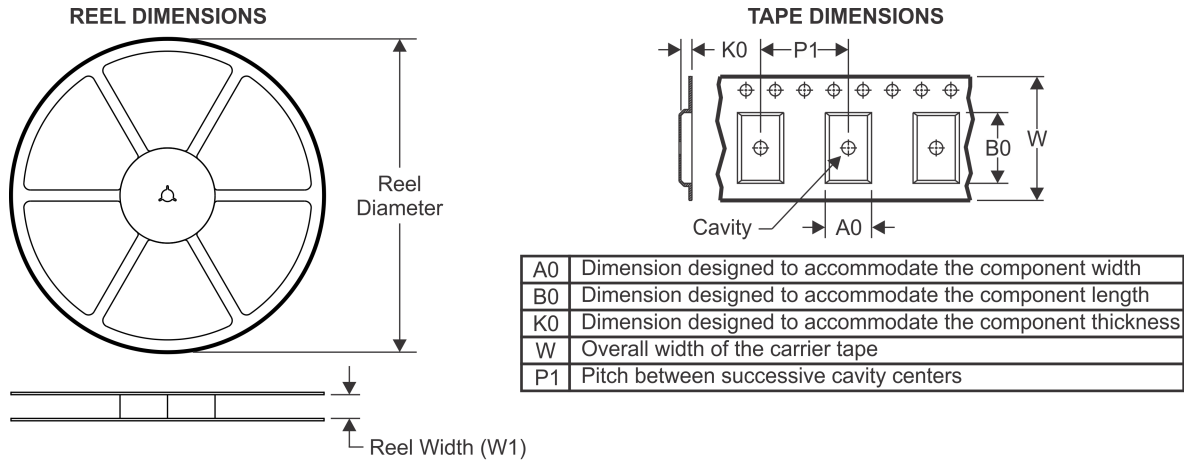
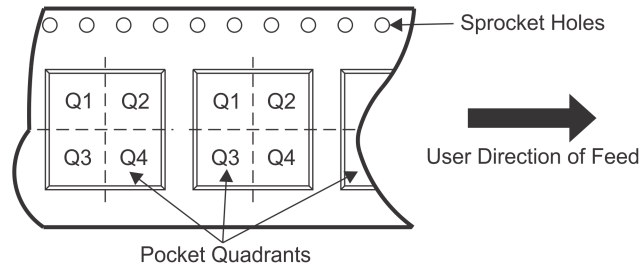
TAPE AND REEL INFORMATION

QUADRANT ASSIGNMENTS FOR PIN 1 ORIENTATION IN TAPE

*All dimensions are nominal

Device	Package Type	Package Drawing	Pins	SPQ	Reel Diameter (mm)	Reel Width W1 (mm)	A0 (mm)	B0 (mm)	K0 (mm)	P1 (mm)	W (mm)	Pin1 Quadrant
BQ51010BYFPR	DSBGA	YFP	28	3000	180.0	8.4	2.0	3.13	0.6	4.0	8.0	Q1
BQ51010BYFPT	DSBGA	YFP	28	250	180.0	8.4	2.0	3.13	0.6	4.0	8.0	Q1

TAPE AND REEL BOX DIMENSIONS



*All dimensions are nominal

Device	Package Type	Package Drawing	Pins	SPQ	Length (mm)	Width (mm)	Height (mm)
BQ51010BYFPR	DSBGA	YFP	28	3000	182.0	182.0	20.0
BQ51010BYFPT	DSBGA	YFP	28	250	182.0	182.0	20.0

MECHANICAL DATA

YFP (R-XBGA-N28)

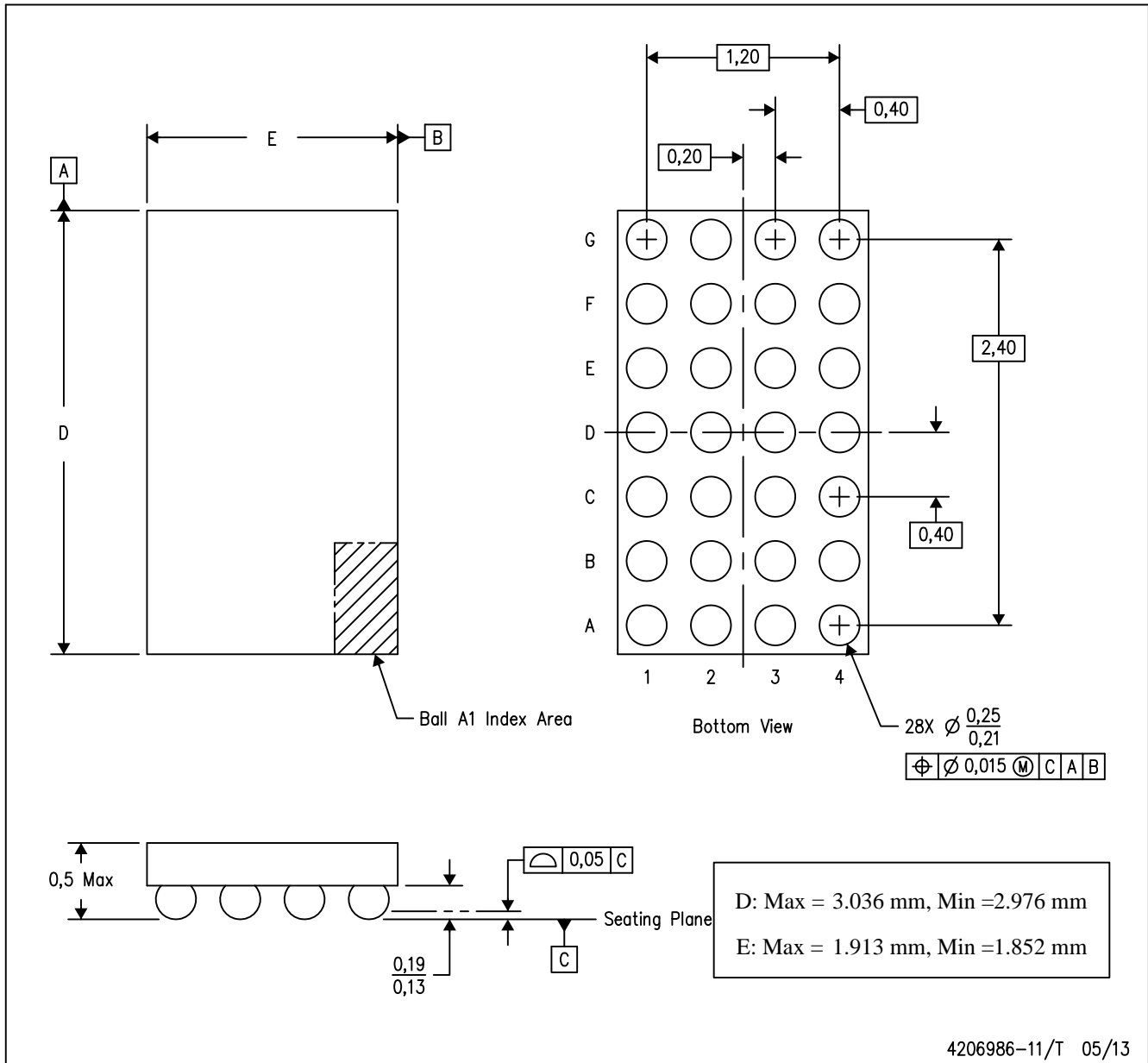
DIE-SIZE BALL GRID ARRAY



- NOTES:
- A. All linear dimensions are in millimeters. Dimensioning and tolerancing per ASME Y14.5M-1994.
 - B. This drawing is subject to change without notice.
 - C. NanoFree™ package configuration.

NanoFree is a trademark of Texas Instruments

重要声明和免责声明

TI 提供技术和可靠性数据（包括数据表）、设计资源（包括参考设计）、应用或其他设计建议、网络工具、安全信息和其他资源，不保证没有瑕疵且不做任何明示或暗示的担保，包括但不限于对适销性、某特定用途方面的适用性或不侵犯任何第三方知识产权的暗示担保。

这些资源可供使用 TI 产品进行设计的熟练开发人员使用。您将自行承担以下全部责任：(1) 针对您的应用选择合适的 TI 产品，(2) 设计、验证并测试您的应用，(3) 确保您的应用满足相应标准以及任何其他安全、安保或其他要求。这些资源如有变更，恕不另行通知。TI 授权您仅可将这些资源用于研发本资源所述的 TI 产品的应用。严禁对这些资源进行其他复制或展示。您无权使用任何其他 TI 知识产权或任何第三方知识产权。您应全额赔偿因在这些资源的使用中对 TI 及其代表造成的任何索赔、损害、成本、损失和债务，TI 对此概不负责。

TI 提供的产品受 TI 的销售条款 (<https://www.ti.com.cn/zh-cn/legal/termsofsale.html>) 或 [ti.com.cn](https://www.ti.com.cn) 上其他适用条款/TI 产品随附的其他适用条款的约束。TI 提供这些资源并不会扩展或以其他方式更改 TI 针对 TI 产品发布的适用的担保或担保免责声明。

邮寄地址：上海市浦东新区世纪大道 1568 号中建大厦 32 楼，邮政编码：200122

Copyright © 2021 德州仪器半导体技术（上海）有限公司