

INA165x SoundPlus™ 高共模抑制线路接收器

1 特性

- 高共模抑制：**91dB**（典型值）
- 高输入阻抗：**1MΩ** 差分
- 超低噪声：**-104.7dBu**，未加权
- 超低总谐波失真 + 噪声：**-120dB THD+N**（22dBu，22kHz 带宽）
- 高带宽：**2.7MHz**
- 低静态电流：**6mA**（INA1651，典型值）
- 短路保护
- 集成电磁干扰 (EMI) 滤波器
- 宽电源电压范围：**±2.25V 至 ±18V**
- 采用小型 **14 引脚 TSSOP** 封装

2 应用

- 差分音频接口
- 音频输入电路
- 线路驱动器
- 音频功率放大器
- 音频分析仪
- 高端影音 (A/V) 接收器

3 说明

双通道 INA1650 和单通道 INA1651 (INA165x) SoundPlus™ 音频线路接收器可实现 91dB 的超高共模抑制比 (CMRR)，同时对于 22dBu 信号电平可在 1kHz 时保持 -120dB 的超低 THD+N。片上电阻器的精密匹配特性为 INA165x 器件提供了出色的 CMRR 性能。这些电阻器具有远远优于外部组件的匹配特性，并且不受印刷电路板 (PCB) 布局所导致的失配问题的影响。不同于其他线路接收器产品，INA165x CMRR 在额定温度范围内能保持特性不变，经生产测试可在各种应用中提供始终如一的性能。

INA165x 器件支持 ±2.25V 到 ±18V 的宽电源电压范围，电源电流为 10.5mA。除线路接收器通道之外，INA165x 还包含一个缓冲的中间电压基准输出，因此可将其配置为用于双电源或单电源应用。中间电源输出可用作信号链中其他模拟电路的偏置电压。这些器件额定工作温度范围为 -40°C 至 +125°C。

器件信息⁽¹⁾

器件型号	封装	封装尺寸 (标称值)
INA1650	TSSOP (14)	4.40mm × 5.00mm
INA1651	TSSOP (14)	4.40mm × 5.00mm

(1) 如需了解所有可用封装，请参阅数据表末尾的封装选项附录。

INA165x 简化内部原理图

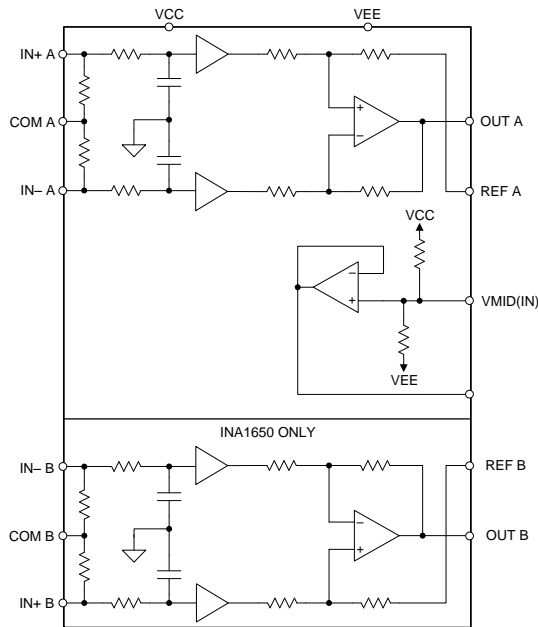

CMRR 直方图 (5746 通道)

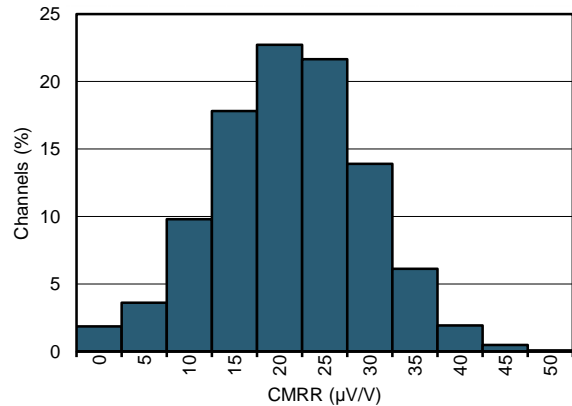

目录

1	特性	1	8	Application and Implementation	18
2	应用	1	8.1	Application Information.....	18
3	说明	1	8.2	Typical Applications	22
4	修订历史记录	2	9	Power Supply Recommendations	29
5	Pin Configuration and Functions	3	10	Layout	29
6	Specifications	5	10.1	Layout Guidelines	29
6.1	Absolute Maximum Ratings	5	10.2	Layout Examples.....	30
6.2	ESD Ratings.....	5	11	器件和文档支持	32
6.3	Recommended Operating Conditions.....	5	11.1	器件支持	32
6.4	Thermal Information	5	11.2	文档支持	32
6.5	Electrical Characteristics:	6	11.3	相关链接	32
6.6	Typical Characteristics	8	11.4	接收文档更新通知	33
7	Detailed Description	15	11.5	社区资源	33
7.1	Overview	15	11.6	商标	33
7.2	Functional Block Diagram	15	11.7	静电放电警告	33
7.3	Feature Description.....	15	11.8	术语表	33
7.4	Device Functional Modes.....	17	12	机械、封装和可订购信息	33

4 修订历史记录

注：之前版本的页码可能与当前版本有所不同。

Changes from Revision A (September 2018) to Revision B	Page
• 已更改 将 INA1651 器件从产品预览更改为生产数据（正在供货）	1

Changes from Original (September 2018) to Revision A	Page
• 已添加 新的 INA1651 作为预告信息	1

5 Pin Configuration and Functions

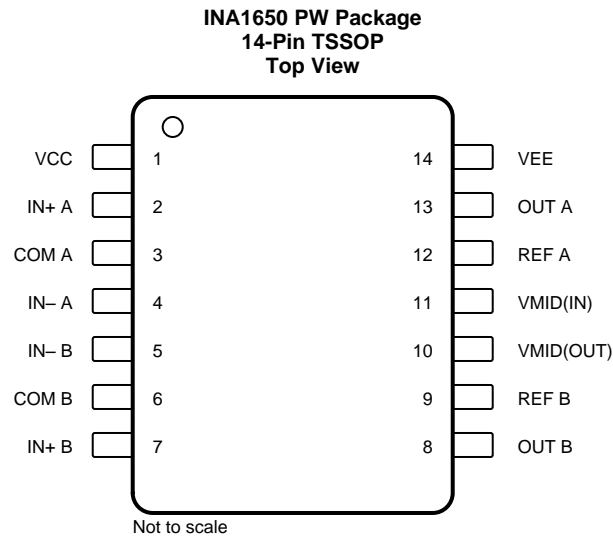

Pin Functions

PIN		I/O	DESCRIPTION
NAME	NO.		
COM A	3	I	Input common, channel A
COM B	6	I	Input common, channel B
IN+ A	2	I	Noninverting input, channel A
IN- A	4	I	Inverting input, channel A
IN+ B	7	I	Noninverting input, channel B
IN- B	5	I	Inverting input, channel B
OUT A	13	O	Output, channel A
OUT B	8	O	Output, channel B
REF A	12	I	Reference input, channel A. This pin must be driven from a low impedance.
REF B	9	I	Reference input, channel B. This pin must be driven from a low impedance.
VCC	1	—	Positive (highest) power supply
VEE	14	—	Negative (lowest) power supply
VMID(IN)	11	I	Input node of internal supply divider. Connect a capacitor to this pin to reduce noise from the supply divider circuit.
VMID(OUT)	10	O	Buffered output of internal supply divider.

**INA1651 PW Package
14-Pin TSSOP
Top View**

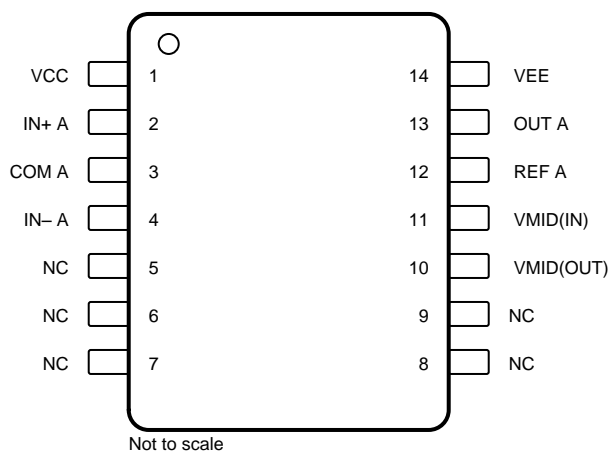

Not to scale

Pin Functions

PIN		I/O	DESCRIPTION
NAME	NO.		
COM A	3	I	Input common, channel A
IN+ A	2	I	Noninverting input, channel A
IN- A	4	I	Inverting input, channel A
NC	5	—	No internal connection
NC	6	—	No internal connection
NC	7	—	No internal connection
NC	8	—	No internal connection
NC	9	—	No internal connection
OUT A	13	O	Output, channel A
REF A	12	I	Reference input, channel A. This pin must be driven from a low impedance.
VCC	1	—	Positive (highest) power supply
VEE	14	—	Negative (lowest) power supply
VMID(IN)	11	I	Input node of internal supply divider. Connect a capacitor to this pin to reduce noise from the supply divider circuit.
VMID(OUT)	10	O	Buffered output of internal supply divider.

6 Specifications

6.1 Absolute Maximum Ratings

over operating free-air temperature range (unless otherwise noted)⁽¹⁾

		MIN	MAX	UNIT
Voltage	Supply voltage, $V_S = (V+) - (V-)$		40	V
	Input voltage (Signal inputs, enable, ground)	$(V-) - 0.5$	$(V+) + 0.5$	
	Input differential voltage		$(V+) - (V-)$	
Current	Input current (all pins except power-supply pins)		±10	mA
	Output short-circuit ⁽²⁾	Continuous		
Temperature	Operating, T_A	-55	125	°C
	Junction, T_J		150	
	Storage, T_{stg}	-65	150	

- (1) Stresses beyond those listed under *Absolute Maximum Ratings* may cause permanent damage to the device. These are stress ratings only, which do not imply functional operation of the device at these or any other conditions beyond those indicated under *Recommended Operating Conditions*. Exposure to absolute-maximum-rated conditions for extended periods may affect device reliability.
- (2) Short-circuit to $V_S / 2$ (ground in symmetrical dual supply setups), one amplifier per package.

6.2 ESD Ratings

			VALUE	UNIT
INA1650				
$V_{(ESD)}$	Electrostatic discharge	Human-body model (HBM), per ANSI/ESDA/JEDEC JS-001 ⁽¹⁾	±4000	V
		Charged-device model (CDM), per JEDEC specification JESD22-C101 ⁽²⁾	±1000	
INA1651				
$V_{(ESD)}$	Electrostatic discharge	Human-body model (HBM), per ANSI/ESDA/JEDEC JS-001 ⁽¹⁾	±4000	V
		Charged-device model (CDM), per JEDEC specification JESD22-C101 ⁽²⁾	±750	

- (1) JEDEC document JEP155 states that 500-V HBM allows safe manufacturing with a standard ESD control process.
- (2) JEDEC document JEP157 states that 250-V CDM allows safe manufacturing with a standard ESD control process.

6.3 Recommended Operating Conditions

over operating free-air temperature range (unless otherwise noted)

	MIN	NOM	MAX	UNIT
Supply voltage ($V+ - V-$)	4.5 (±2.25)		36 (±18)	V
Specified temperature	-40		125	°C

6.4 Thermal Information

THERMAL METRIC ⁽¹⁾		INA1650	INA1651	UNIT
		PW (TSSOP)	PW (TSSOP)	
		14 PINS	14 PINS	
$R_{\theta JA}$	Junction-to-ambient thermal resistance	97.0	99.4	°C/W
$R_{\theta JC(top)}$	Junction-to-case (top) thermal resistance	22.6	29.9	°C/W
$R_{\theta JB}$	Junction-to-board thermal resistance	40.4	42.6	°C/W
ψ_{JT}	Junction-to-top characterization parameter	0.9	1.5	°C/W
ψ_{JB}	Junction-to-board characterization parameter	39.6	42.0	°C/W
$R_{\theta JC(bot)}$	Junction-to-case (bottom) thermal resistance	N/A	N/A	°C/W

- (1) For more information about traditional and new thermal metrics, see the [Semiconductor and IC Package Thermal Metrics application report](#).

6.5 Electrical Characteristics:

 at $T_A = 25^\circ\text{C}$, $V_S = \pm 2.25\text{ V to } \pm 18\text{ V}$, $V_{CM} = V_{OUT} = \text{mid supply}$, and $R_L = 2\text{ k}\Omega$ (unless otherwise noted)

PARAMETER		TEST CONDITIONS	MIN	TYP	MAX	UNIT
AUDIO PERFORMANCE						
THD+N	Total harmonic distortion + noise	$V_O = 3 V_{RMS}$, $f = 1\text{ kHz}$, 90-kHz measurement bandwidth, $V_S = \pm 18\text{ V}$		0.00039%		
		$V_{IN} = 22\text{ dBu}$ (9.7516 V_{RMS}), $F_{IN} = 1\text{ kHz}$, $V_S = \pm 18\text{ V}$, 90-kHz measurement bandwidth		0.000174%		
IMD	Intermodulation distortion	SMPTE and DIN two-tone, 4:1 (60 Hz and 7 kHz) $V_O = 3 V_{RMS}$, 90-kHz measurement bandwidth		0.0005%		
				-106.1		dB
		CCIF twin-tone (19 kHz and 20 kHz), $V_O = 3 V_{RMS}$, 90-kHz measurement bandwidth		0.00066%		
				-103.6		dB
AC PERFORMANCE						
BW	Small-signal bandwidth			2.7		MHz
SR	Slew rate			10		V/ μs
	Full-power bandwidth ⁽¹⁾	$V_O = 1 V_P$		1.59		MHz
PM	Phase margin	$C_L = 20\text{ pF}$		71°		
		$C_L = 200\text{ pF}$		54°		
t_s	Settling time	To 0.01%, $V_S = \pm 18\text{ V}$, 10-V step		2.2		μs
	Overload recovery time			330		ns
	Channel separation	$f = 1\text{ kHz}$, REF and COM pins connected to ground		140		dB
		$f = 1\text{ kHz}$, REF and COM pins connected to VMID(OUT)		130		dB
	EMI/RFI filter corner frequency			80		MHz
NOISE						
	Output voltage noise	$f = 20\text{ Hz to } 20\text{ kHz}$, no weighting		4.5		μV_{RMS}
				-104.7		dBu
e_n	Output voltage noise density ⁽²⁾	$f = 100\text{ Hz}$		47		nV/\sqrt{Hz}
		$f = 1\text{ kHz}$		31		
OFFSET VOLTAGE						
V_{OS}	Output offset voltage			± 1	± 3	mV
		$T_A = -40^\circ\text{C to } +125^\circ\text{C}^{(2)}$			± 4	
dV_{OS}/dT	Output offset voltage drift ⁽²⁾	$T_A = -40^\circ\text{C to } +125^\circ\text{C}$		2	7	$\mu V/^\circ\text{C}$
PSRR	Power-supply rejection ratio			2		$\mu V/V$
GAIN						
	Gain			1		V/V
	Gain error			0.04%	0.05%	
		$T_A = -40^\circ\text{C to } +125^\circ\text{C}^{(2)}$		0.05%	0.06%	
	Gain nonlinearity	$V_S = \pm 18\text{ V}$, $-10\text{ V} < V_O < 10\text{ V}^{(2)}$		1	5	ppm
INPUT VOLTAGE RANGE						
V_{CM}	Common-mode voltage range		$(V-) + 0.25$		$(V+) - 2$	V
CMRR	Common-mode rejection ratio	$(V-) + 0.25\text{ V} \leq V_{CM} \leq (V+) - 2\text{ V}$, REF and COM pins connected to ground, $V_S = \pm 18\text{ V}$	85	91		dB
		$T_A = -40^\circ\text{C to } +125^\circ\text{C}^{(2)}$	82	89		
		$(V-) + 0.25\text{ V} \leq V_{CM} \leq (V+) - 2\text{ V}$, REF and COM pins connected to VMID(OUT), $V_S = \pm 18\text{ V}$	82	86		
		$T_A = -40^\circ\text{C to } +125^\circ\text{C}^{(2)}$	76	84		
CMRR	Common-mode rejection ratio	$(V-) + 0.25\text{ V} \leq V_{CM} \leq (V+) - 2\text{ V}$, REF and COM pins connected to ground, $V_S = \pm 18\text{ V}$, R_S mismatch = 20 Ω		84		dB

 (1) Full-power bandwidth = $SR / (2\pi \times V_P)$, where SR = slew rate.

(2) Specified by design and characterization.

Electrical Characteristics: (continued)

at $T_A = 25^\circ\text{C}$, $V_S = \pm 2.25\text{ V}$ to $\pm 18\text{ V}$, $V_{CM} = V_{OUT} = \text{midsupply}$, and $R_L = 2\text{ k}\Omega$ (unless otherwise noted)

PARAMETER		TEST CONDITIONS	MIN	TYP	MAX	UNIT	
INPUT IMPEDANCE							
Differential			850	1000	1150	k Ω	
Common-mode			212.5	250	287.5	k Ω	
Input resistance mismatch				0.01%	0.25%		
SUPPLY DIVIDER CIRCUIT							
Nominal output voltage			[(V+) + (V-)] / 2			V	
Output voltage offset		$V_{MID(IN)} = ((V+) + (V-) / 2$		2	4	mV	
Input impedance		$V_{MID(IN)}$ pin, $f = 1\text{ kHz}$		250		k Ω	
Output resistance		$V_{MID(OUT)}$ pin		0.35		Ω	
Output voltage noise		20 Hz to 20 kHz, $C_{MID} = 1\text{ }\mu\text{F}$		1.56		μV_{RMS}	
Output capacitive load limit		Phase margin > 45°, $R_{ISO} = 0\text{ }\Omega$		150		pF	
OUTPUT							
V_O	Voltage output swing from rail	Positive rail	$R_L = 2\text{ k}\Omega$	350		mV	
			$R_L = 600\text{ }\Omega$	1100			
		Negative rail	$R_L = 2\text{ k}\Omega$	430			
			$R_L = 600\text{ }\Omega$	1300			
Z_{OUT}	Output impedance	$f \leq 100\text{ kHz}$, $I_{OUT} = 0\text{ A}$		< 1		Ω	
I_{SC}	Short-circuit current	$V_S = \pm 18\text{ V}$		± 75		mA	
C_{LOAD}	Capacitive load drive			See 图 19		pF	
POWER SUPPLY							
I_Q	Quiescent current	$I_{OUT} = 0\text{ A}$, INA1651		4.6	6	6.9	mA
			$T_A = -40^\circ\text{C}$ to $+125^\circ\text{C}^{(2)}$				
		$I_{OUT} = 0\text{ A}$, INA1650		8	10.5	12	
			$T_A = -40^\circ\text{C}$ to $+125^\circ\text{C}^{(2)}$				

6.6 Typical Characteristics

at $T_A = 25^\circ\text{C}$, $V_S = \pm 18\text{ V}$, $V_{CM} = V_{OUT} = \text{midsupply}$, and $R_L = 2\text{ k}\Omega$ (unless otherwise noted)

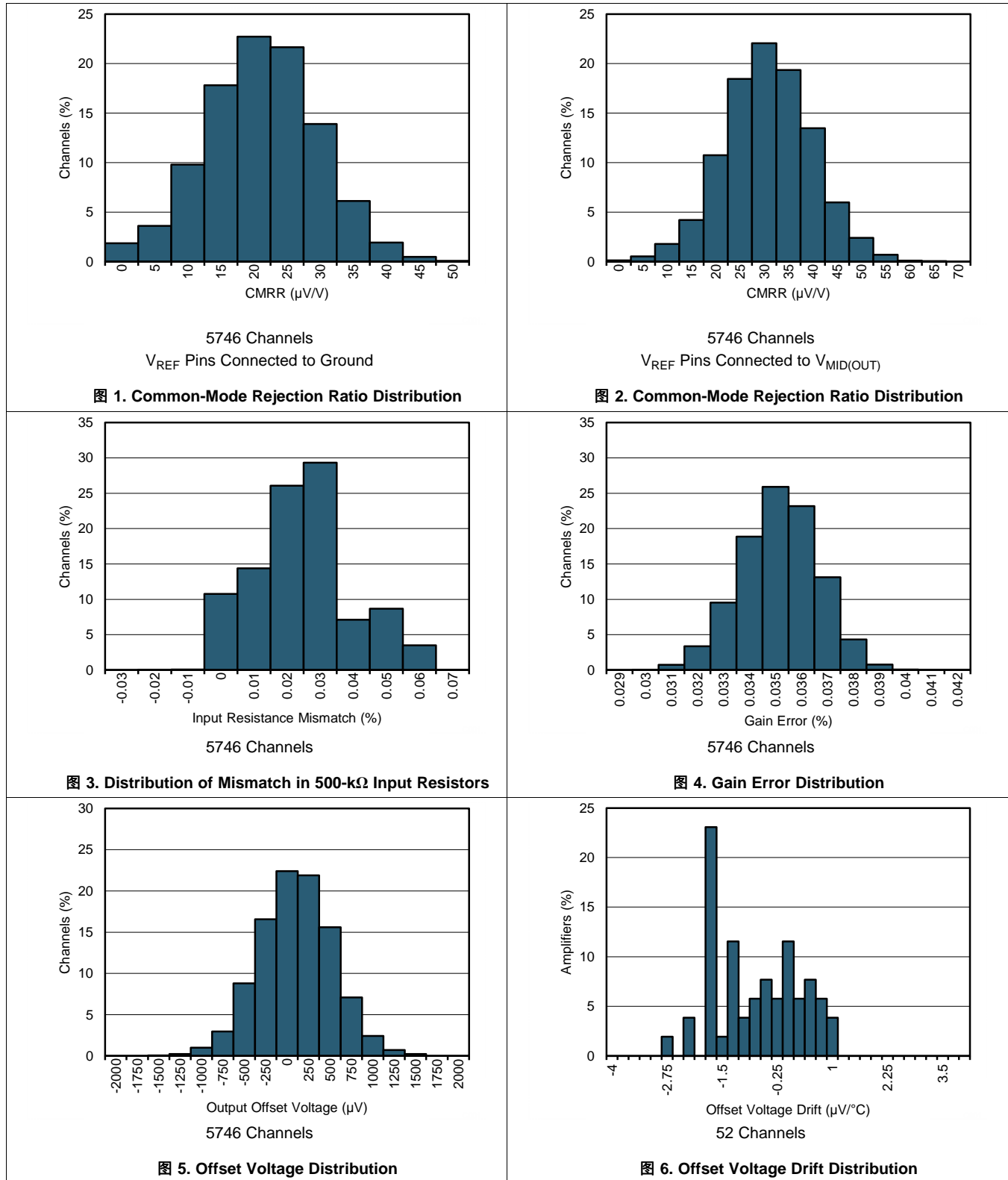

Typical Characteristics (接下页)

at $T_A = 25^\circ\text{C}$, $V_S = \pm 18\text{ V}$, $V_{CM} = V_{OUT} = \text{mid supply}$, and $R_L = 2\text{ k}\Omega$ (unless otherwise noted)



图 7. Frequency Response



图 8. Maximum Output Voltage vs Frequency

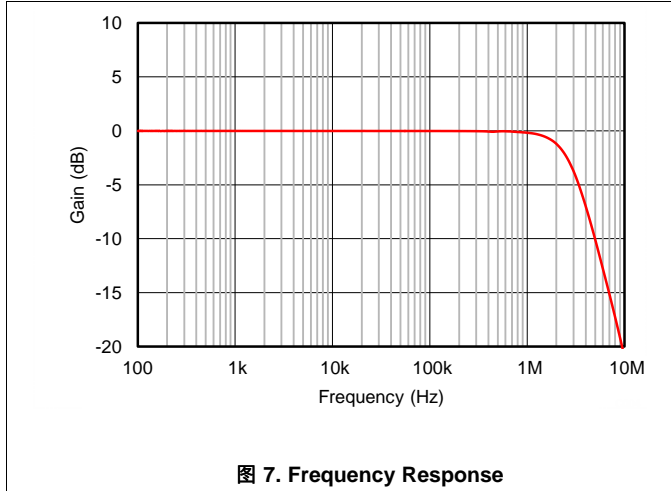

图 9. Common-Mode Rejection Ratio vs Frequency

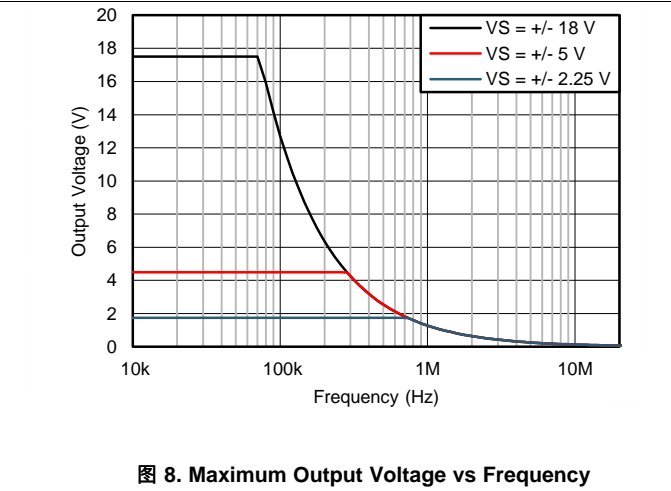

图 10. Power Supply Rejection Ratio vs Frequency

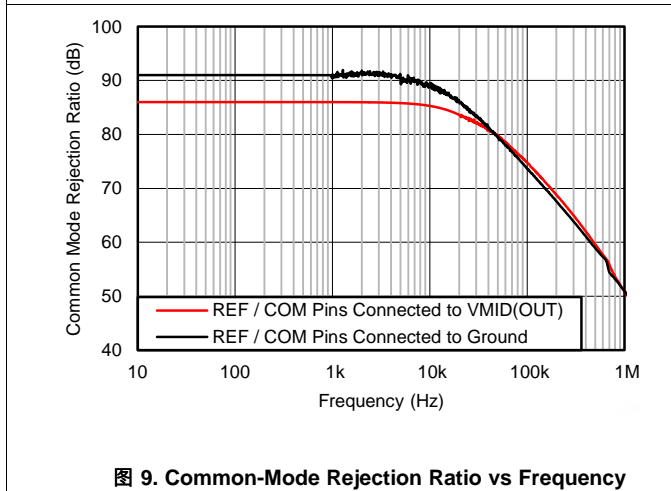

图 11. Voltage Noise Spectral Density

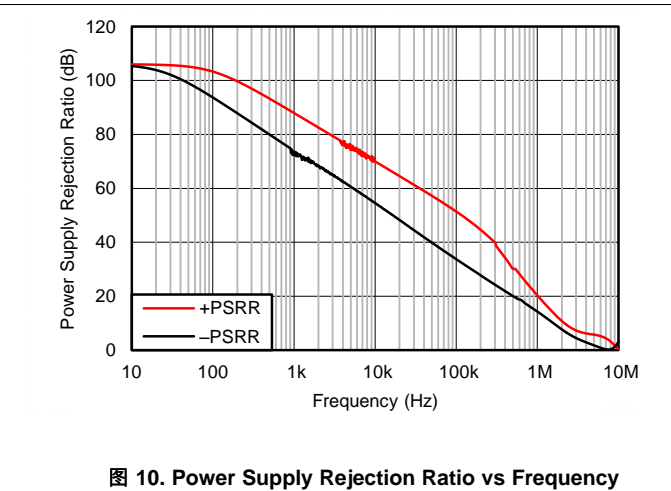

图 12. THD+N vs Frequency

Typical Characteristics (接下页)

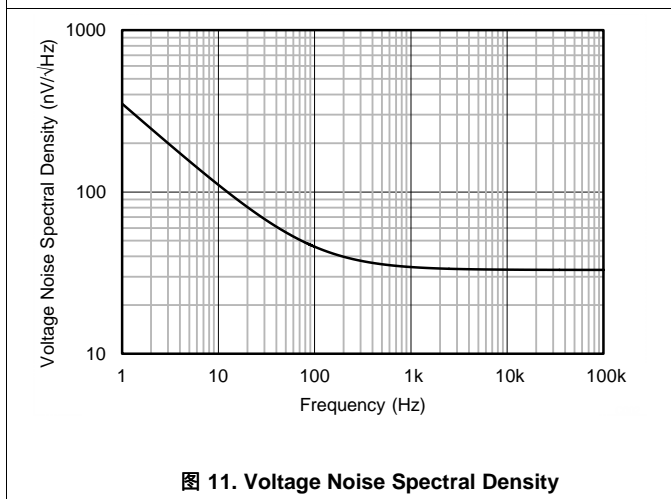
at $T_A = 25^\circ\text{C}$, $V_S = \pm 18\text{ V}$, $V_{CM} = V_{OUT} = \text{mid supply}$, and $R_L = 2\text{ k}\Omega$ (unless otherwise noted)

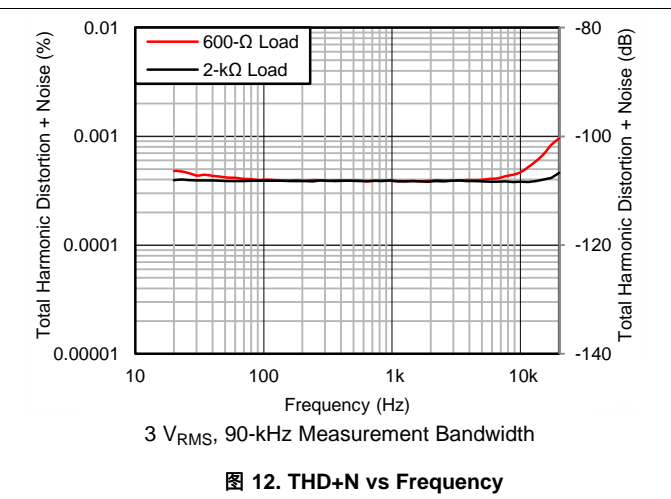
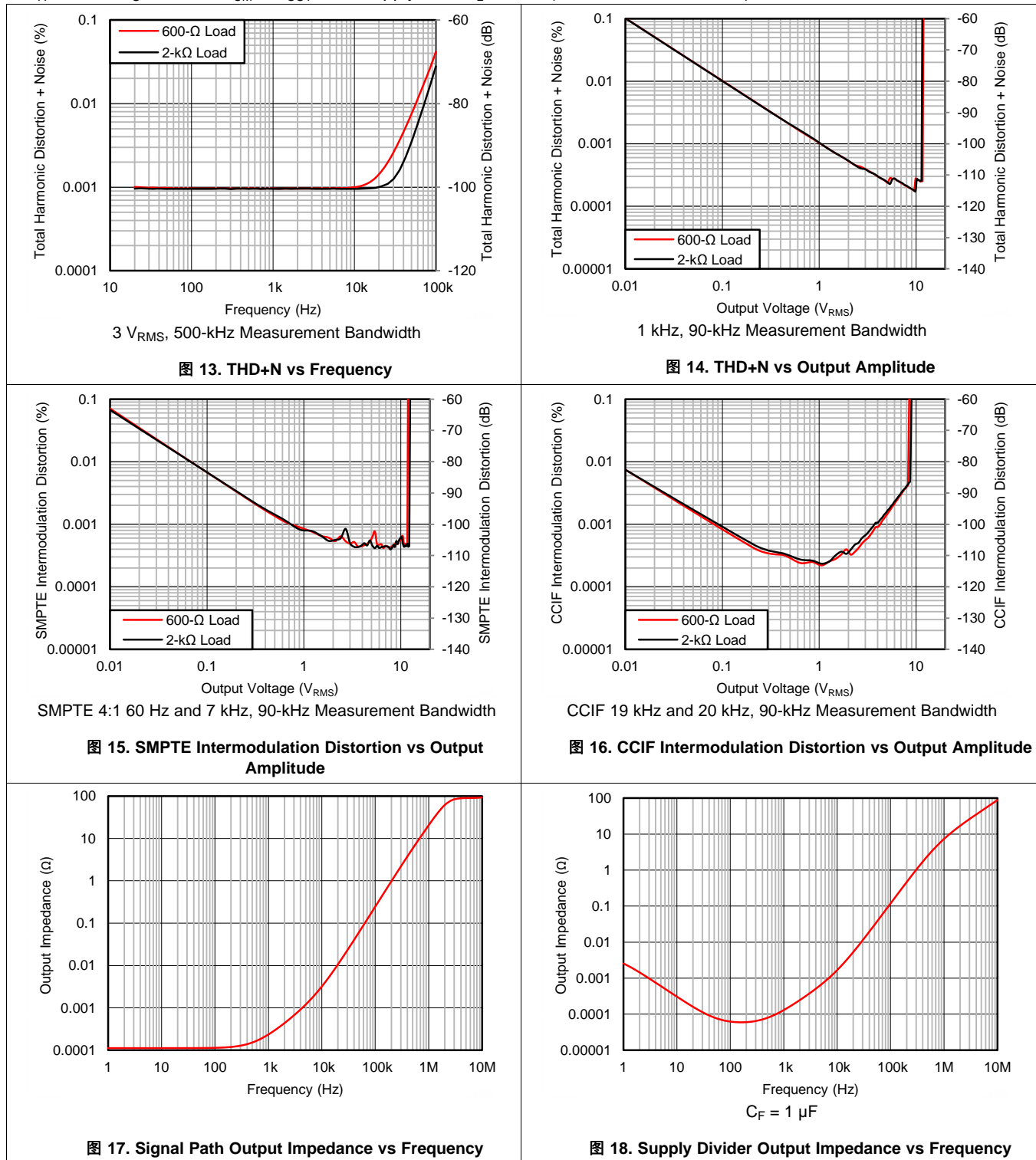

Typical Characteristics (接下页)

at $T_A = 25^\circ\text{C}$, $V_S = \pm 18\text{ V}$, $V_{CM} = V_{OUT} = \text{mid supply}$, and $R_L = 2\text{ k}\Omega$ (unless otherwise noted)



图 19. Overshoot vs Capacitive Load



图 20. Channel Separation vs Frequency

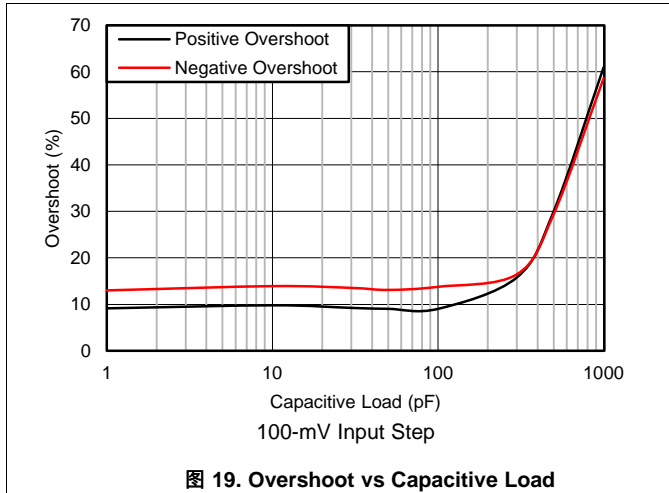

图 21. Small-Signal Step Response

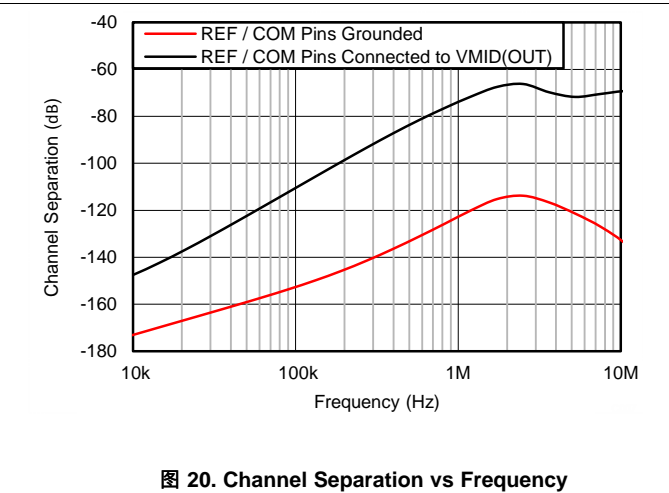

图 22. Large-Signal Step Response

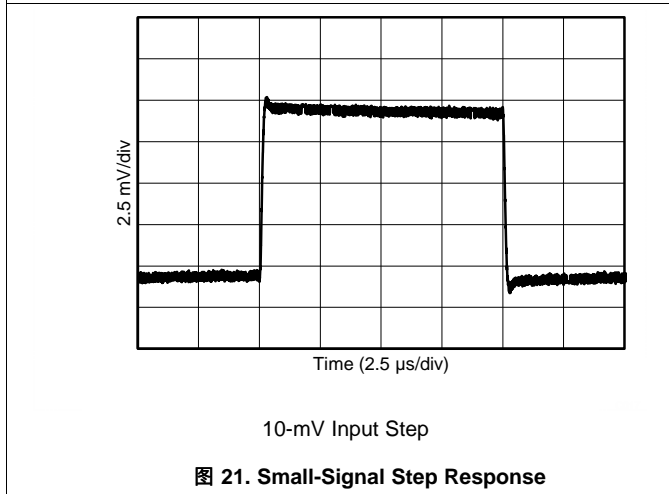

图 23. Rising-Edge Settling Time

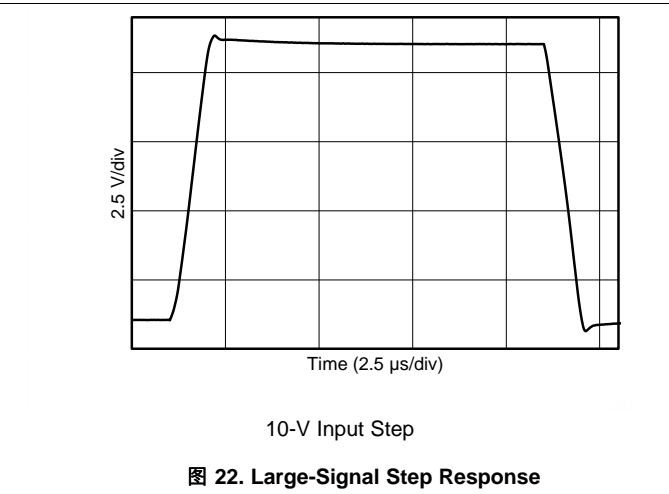

图 24. Falling-Edge Settling Time

Typical Characteristics (接下页)

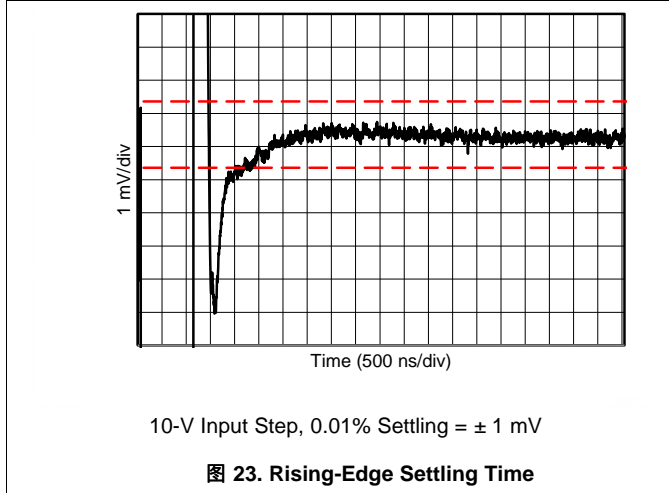
at $T_A = 25^\circ\text{C}$, $V_S = \pm 18\text{ V}$, $V_{CM} = V_{OUT} = \text{mid supply}$, and $R_L = 2\text{ k}\Omega$ (unless otherwise noted)

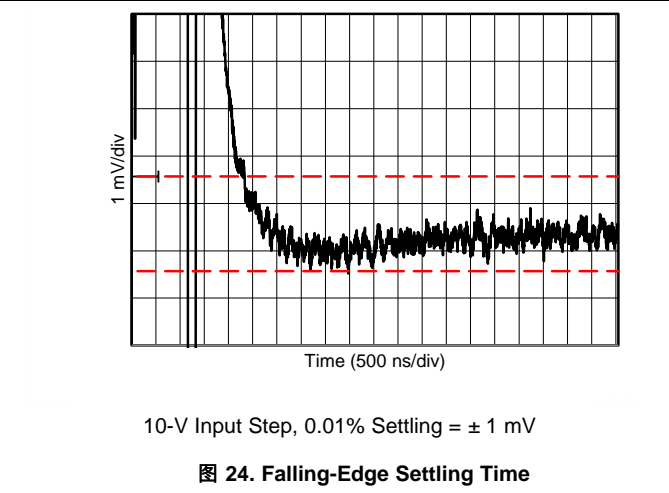
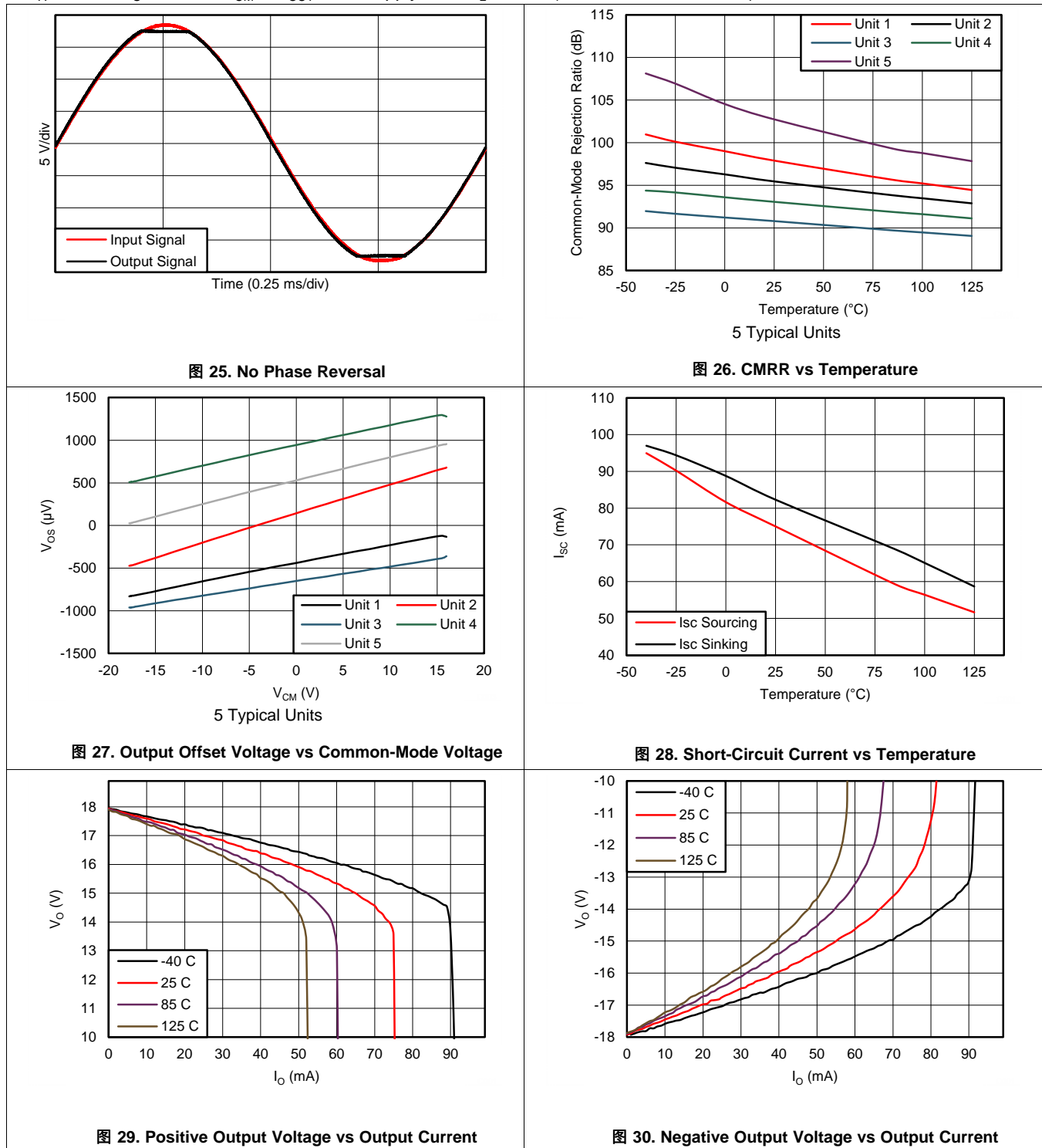

Typical Characteristics (接下页)

at $T_A = 25^\circ\text{C}$, $V_S = \pm 18\text{ V}$, $V_{CM} = V_{OUT} = \text{mid supply}$, and $R_L = 2\text{ k}\Omega$ (unless otherwise noted)



图 31. Power Supply Current vs Power Supply Voltage



图 32. Power Supply Current vs Temperature

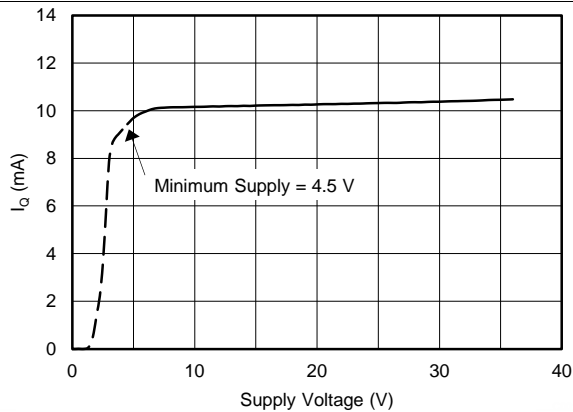

图 33. Input Common-Mode Voltage vs Output Voltage

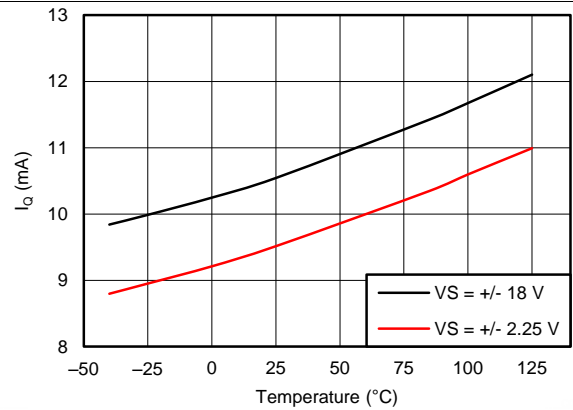

图 34. Input Common-Mode Voltage vs Output Voltage

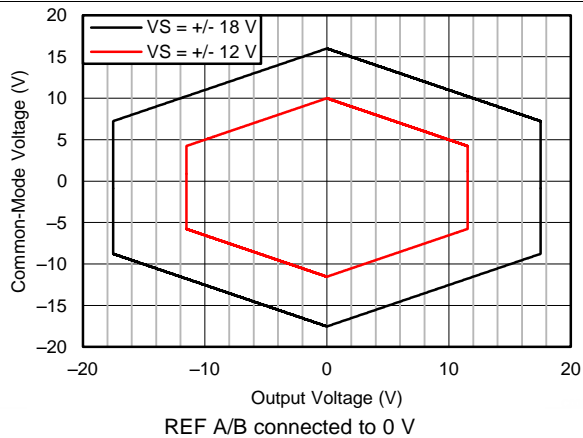

图 35. Input Common-Mode Voltage vs Output Voltage

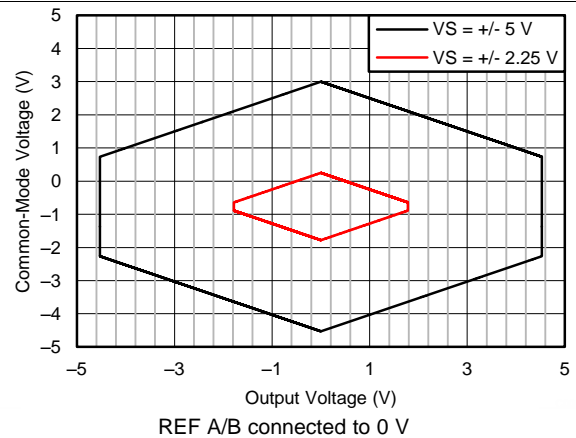

图 36. Input Common-Mode Voltage vs Output Voltage

Typical Characteristics (接下页)

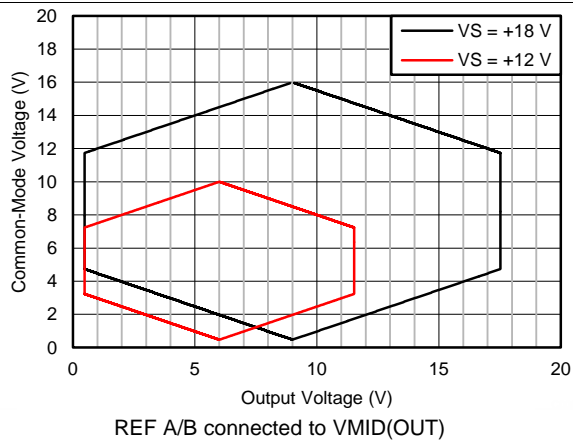
 at $T_A = 25^\circ\text{C}$, $V_S = \pm 18\text{ V}$, $V_{CM} = V_{OUT} = \text{midsupply}$, and $R_L = 2\text{ k}\Omega$ (unless otherwise noted)

7 Detailed Description

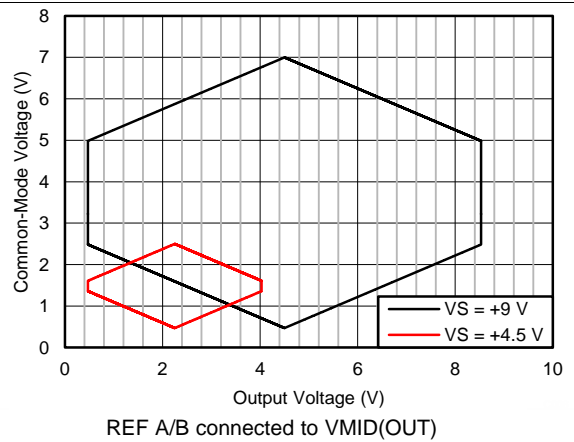
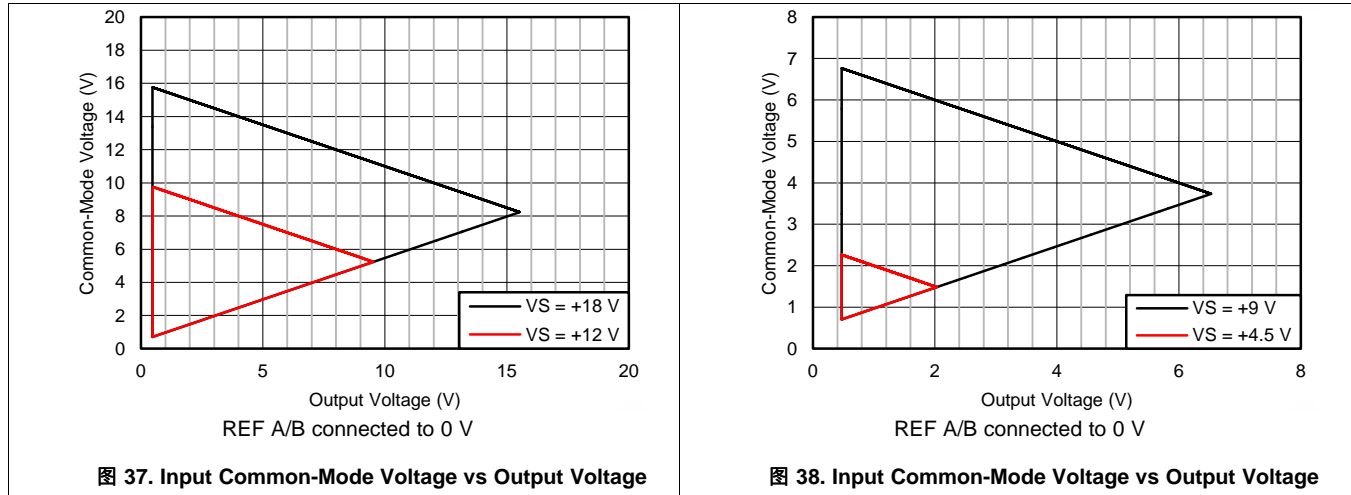
7.1 Overview

The INA165x combines high-performance audio operational amplifier cores with high-precision resistor networks to provide exceptional audio performance and rejection of noise which may be externally coupled into the audio signal path. The INA165x uses an instrumentation amplifier topology with a fixed unity gain to provide high input impedance and a high common-mode rejection ratio (CMRR). Unlike other line receiver products that use a simple four-resistor difference amplifier topology, the INA165x topology provides excellent CMRR even with mismatched source impedances.

7.2 Functional Block Diagram

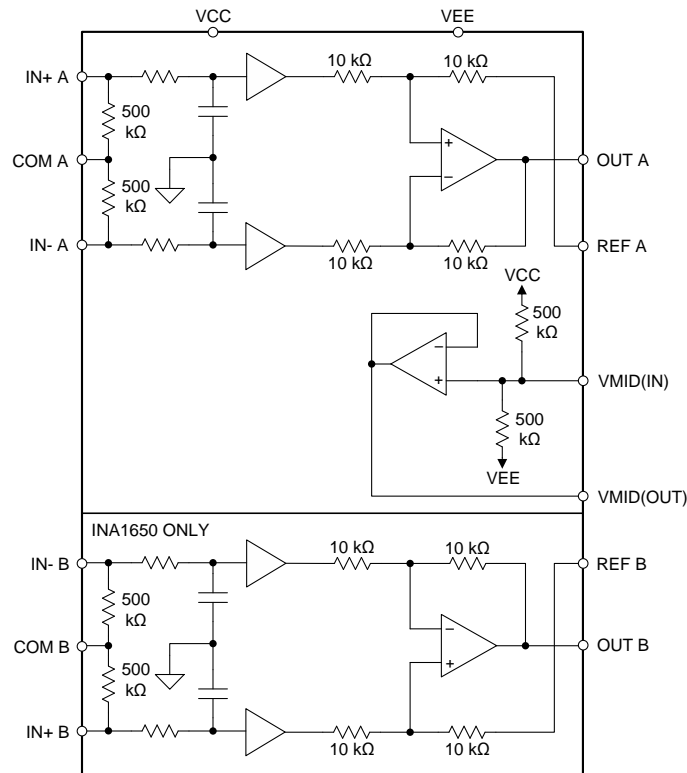

Copyright © 2018, Texas Instruments Incorporated

7.3 Feature Description

7.3.1 Audio Signal Path

图 39 highlights the basic elements present in the audio signal pathway. The primary elements are: input biasing resistors, electromagnetic interference (EMI) filtering, input buffers, and a difference amplifier. The primary role of an audio line receiver is to convert a differential input signal into a single-ended output signal while rejecting noise that is common to both inputs (common-mode noise). The difference amplifier (which consists of an op amp and four matched 10-kΩ resistors) accomplishes this task. The basic transfer function of the circuit is shown in 公式 1:

$$V_{OUT} = (V_{IN+} - V_{IN-}) + V_{REF} \quad (1)$$

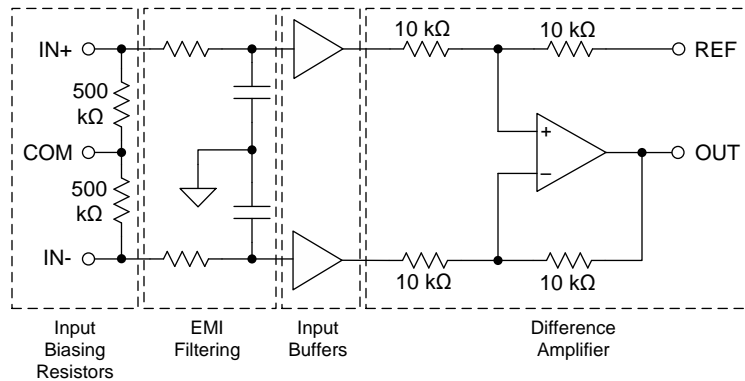
Feature Description (接下页)

Copyright © 2016, Texas Instruments Incorporated

图 39. INA165x Audio Signal Path (Single Channel Shown)

The input buffers prevent external resistances (such as those from the PCB, connectors, or cables) from ruining the precise matching of the internal 10-kΩ resistors which would degrade the high common-mode rejection of the difference amplifier. As is typical of many amplifiers, a small bias current flows into or out of the buffer amplifier inputs. This current must flow to a common potential for the buffer to function properly. The input biasing resistors provide an internal pathway for this current to the COM pin. The COM pin can connect to ground in a dual-supply system or the output of the internal supply divider ($V_{MID(OUT)}$) in single-supply applications. Finally, EMI filtering is added to the input buffers to prevent high-frequency interference signals from propagating through the audio signal pathway.

7.3.2 Supply Divider

The INA165x integrates a supply-divider circuit which may bias the input common-mode voltage and output reference voltage to the halfway point between the applied power supply voltages. The nominal output voltage of the supply divider circuit is shown in [公式 2](#):

$$V_{MID(OUT)} = \frac{VCC + VEE}{2} \quad (2)$$

[图 40](#) illustrates the internal topology of the supply-divider circuit. The supply divider consists of two 500-kΩ resistors connected between the VCC and VEE pins of the INA165x. The noninverting input of a buffer amplifier is connected to the midpoint of the voltage divider that is formed by the 500-kΩ resistors. The buffer amplifier provides a low-impedance output that is required to bias the REF pins without degrading the CMRR. For dual-supply applications where the supply divider circuit may not be used, no connection is required for the $V_{MID(IN)}$ or $V_{MID(OUT)}$ pins.

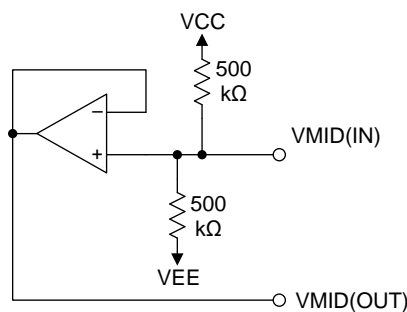

Copyright © 2016, Texas Instruments Incorporated

图 40. Internal Supply Divider Circuit

Feature Description (接下页)

7.3.3 Electrical Overstress

Designers typically ask questions about the capability of an amplifier to withstand electrical overstress. These questions typically focus on the device inputs, but can involve the supply voltage pins or the output pin. Each of these different pin functions have electrical stress limits determined by the voltage breakdown characteristics of the particular semiconductor fabrication process and specific circuits connected to the pin. Additionally, internal ESD protection is built into these circuits to protect them from accidental ESD events both before and during product assembly. A good understanding of basic ESD circuitry and the relevance of circuitry to an electrical overstress event is helpful. 图 41 illustrates the ESD circuits contained in the INA165x. The ESD protection circuitry involves several current-steering diodes that are connected from the input and output pins and routed back to the internal power-supply lines. This protection circuitry is intended to remain inactive during normal circuit operation. The input pins of the INA165x are protected with internal diodes that are connected to the power-supply rails. These diodes clamp the applied signal to prevent the input circuitry from damage. If the input signal voltage exceeds the power supplies by more than 0.3 V, limit the input signal current to less than 10 mA to protect the internal clamp diodes. A series input resistor can typically limit the current. Some signal sources are inherently current-limited and do not require limiting resistors.



图 41. INA165x Internal ESD Protection Circuitry (Single Channel and Supply-Divider Shown for Simplicity)

7.3.4 Thermal Shutdown

If the junction temperature of the INA165x exceeds approximately 170°C, a thermal shutdown circuit disables the amplifier to protect the device from damage. The amplifier is automatically re-enabled after the junction temperature falls below the shutdown threshold temperature. If the condition that caused excessive power dissipation is not removed, the amplifier oscillates between a shutdown and enabled state until the output fault is corrected.

7.4 Device Functional Modes

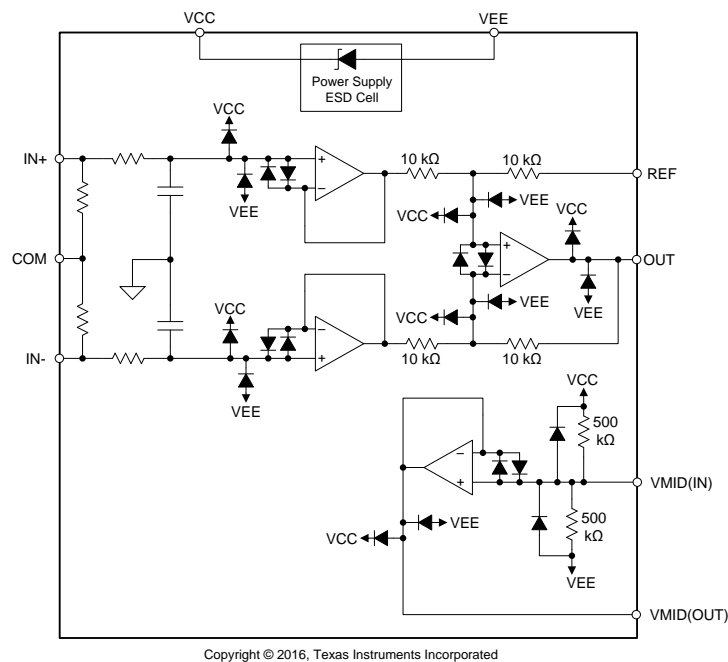
7.4.1 Single-Supply Operation

The INA165x can be used on single power supplies ranging from 4.5 V to 36 V. Use the COM and REF pins to level shift the internal voltages into a linear operating condition. Ideally, connecting the REF and COM pins to a midsupply potential (such as the $V_{MID(OUT)}$ pin) avoids saturating the output of the internal amplifiers.

8 Application and Implementation

注

Information in the following applications sections is not part of the TI component specification, and TI does not warrant its accuracy or completeness. TI's customers are responsible for determining suitability of components for their purposes. Customers should validate and test their design implementation to confirm system functionality.

8.1 Application Information

8.1.1 Input Common-Mode Range

The linear input voltage range of the INA165x input circuitry extends from 350 mV inside the negative supply voltage to 2 V below the positive supply, and maintains 85-dB (minimum) common-mode rejection throughout this range. The INA165x operates over a wide range of power supplies and V_{REF} configurations; providing a comprehensive guide to common-mode range limits for all possible conditions is impractical. The common-mode range for most operating conditions is best calculated using the [INA common-mode range calculating tool](#).

8.1.2 Common-Mode Input Impedance

The high CMRR of many line receivers can degrade by impedance mismatches in the system. [图 42](#) shows a common-mode noise source (V_{CM}) connected to both inputs of a single channel of the INA165x. An external parasitic resistance (R_{EXT}) represents the mismatch in impedances between the common-mode noise source and the inputs of the INA165x. This mismatched impedance may be due to PCB layout, connectors, cabling, passive component tolerances, or the circuit topology. The presence of R_{EXT} in series with the IN+ input degrades the overall CMRR of the system because the voltage at IN+ is no longer equal to the voltage at IN-. Therefore, a portion of the common-mode noise converts to a differential signal and passes to the output.

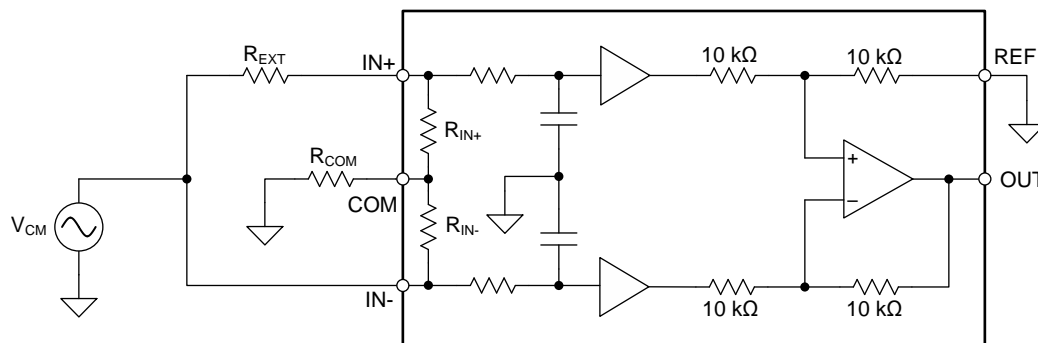

Copyright © 2016, Texas Instruments Incorporated

图 42. A Single Channel of the INA165x Shown With Source Impedance Mismatch (R_{EXT}) and Optional Resistor (R_{COM})

While the INA165x is significantly more resistant to these effects than typical line receivers, connecting a resistor (R_{COM}) from the COM pin to the system ground further improves CMRR performance. [图 43](#) shows the CMRR of the INA165x (typical CMRR of 92 dB) for increasing source impedance mismatches. If the COM pin is connected directly to ground (R_{COM} equal to 0 Ω), a 20-Ω source impedance mismatch degrades the CMRR from 92 dB to 83.7 dB. However, if R_{COM} has a value of 1 MΩ, the CMRR only degrades to 89.6 dB, which is an improvement of approximately 6 dB.

Application Information (接下页)



图 43. CMRR vs Source Impedance Mismatch for Different R_{COM} Values

R_{COM} does not need to be a high-precision resistor with a very tight tolerance. Low cost 5% or 1% resistors can be used with no degradation in overall performance. The addition of R_{COM} does not increase the noise of the audio signal path.

In single-supply systems where AC coupling is used at the inputs of the INA165x, adding R_{COM} lengthens the start-up time of the circuit. The input AC-coupling capacitors are charged to the midsupply voltage through the R_{COM} resistor, which may take a substantial amount of time if R_{COM} has a large value (such as 1 MΩ). Do not use R_{COM} in these systems if start-up time is a concern. In dual-supply systems with input AC-coupling capacitors, the capacitor voltage does not need to be charged to a midsupply point, since the capacitor voltage settles to ground by default. Therefore, R_{COM} does not increase start-up time in dual-supply systems.

8.1.3 Start-Up Time in Single-Supply Applications

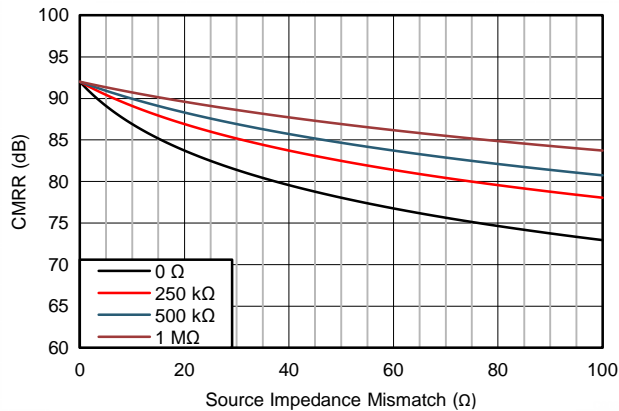
The internal supply divider of the INA165x is constructed using two 500-kΩ resistors connected in series between the VCC and VEE pins. These resistors are matched on-chip to provide a reference voltage that is exactly one half of the power supply voltage. Noise from the power supplies and thermal noise from the resistors degrades the overall audio performance of the INA165x if allowed to enter the signal path. Therefore, TI recommends a filter capacitor (C_F) is connected to the VMID(IN) pin, as shown in 图 44 The C_F capacitor forms a low-pass filter with the internal 500-kΩ resistors. Noise above the corner frequency of this filter is passed to ground and is removed from the audio signal path. The corner frequency of the filter is shown in 公式 3:

$$F_{-3dB} = \frac{1}{2 \cdot \pi \cdot 250 \text{ k}\Omega \cdot C_F} \tag{3}$$

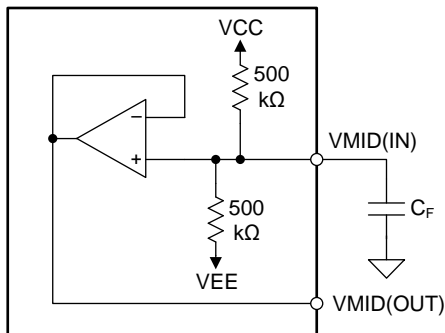

Copyright © 2016, Texas Instruments Incorporated

图 44. Connect a Capacitor (C_F) to the VMID(IN) Pin to Reduce Noise from the Voltage Divider

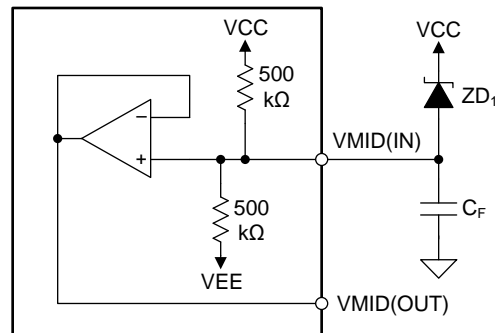

Copyright © 2016, Texas Instruments Incorporated

图 45. A Zener Diode (ZD1) Connected to the Positive Supply Can Decrease Start-Up Time

Application Information (接下页)

When power is applied to the INA165x, the filter capacitor (C_F) charges through the internal 500-k Ω resistors. If the C_F capacitor has a large value, the time required for $V_{MID(OUT)}$ to reach the final midsupply voltage may be extensive. Adding a zener diode from the $V_{MID(IN)}$ pin to the positive power supply (as shown in 图 45) reduces this time. The zener voltage must be slightly greater than one half of the power supply voltage.

Using large AC-coupling capacitors increases the start-up time of the line receiver circuit in single-supply applications. When power is applied, the AC-coupling capacitors begin to charge to the midsupply voltage applied to the COM pin through a current flowing through the input resistors as shown in 图 46. The INA165x functions properly when the input common-mode voltage (and the capacitor voltage) is within the specified range. The time required for the input common-mode voltage to reach 98% of the final value is shown in 公式 4:

$$T_{98\%} = 4 \cdot R \cdot C_{IN} = 4 \cdot 500 \text{ k}\Omega \cdot C_{IN} \quad (4)$$

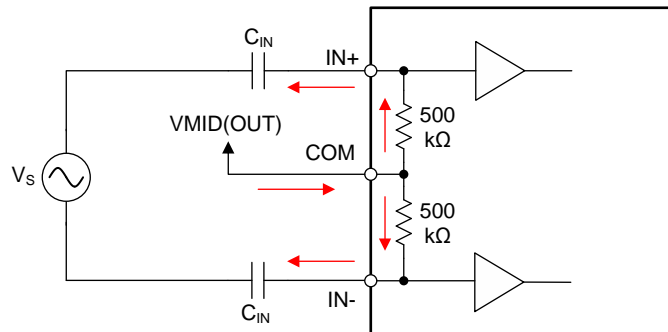

Copyright © 2016, Texas Instruments Incorporated

图 46. AC-Coupling Capacitors Charge to the Midsupply Voltage Through the Input Resistors

8.1.4 Input AC Coupling

The signal path in most audio systems is typically AC-coupled to avoid the propagation of DC voltages, which can potentially damage loudspeakers or saturate power amplifiers. The capacitor values must be selected to pass the desired bandwidth of audio signals. The high-pass corner frequency is calculated with 公式 5:

$$F_C = \frac{1}{2 \cdot \pi \cdot (2 \cdot R_{IN}) \cdot C_{IN}/2} = \frac{1}{2 \cdot \pi \cdot R_{IN} \cdot C_{IN}} \quad (5)$$

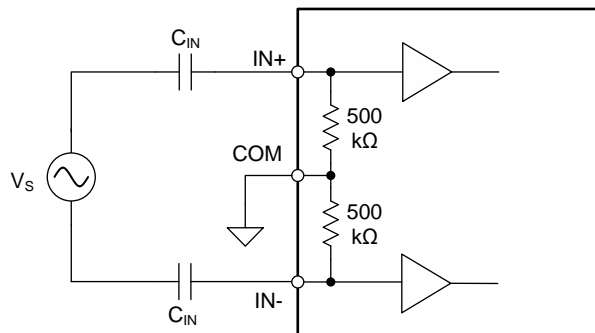

Copyright © 2016, Texas Instruments Incorporated

图 47. AC-Coupling Capacitors Form a High-Pass Filter With INA165x Input Resistors

Application Information (接下页)

Although the input resistors of the INA165x are matched typically within 0.01%, large capacitors are usually mismatched. The mismatch in the values of the AC-coupling capacitors causes the corner frequencies at the two signal inputs (IN+ and IN-) to be different, which can degrade CMRR at low frequency. For this reason, TI recommends placing the high-pass corner frequency well below the audio bandwidth and to use a resistor in series with the COM pin (R_{COM}), as shown in 图 42 if possible. See the [Common-Mode Input Impedance](#) section for more information on placing a resistor in series with the COM pin. 图 48 shows the effect of a 5% mismatch in the values of the input AC-coupling capacitors with and without an R_{COM} resistor. Comparing CMRR at 100 Hz: 1- μ F AC-coupling capacitors with a 5% mismatch degrade the CMRR to 75 dB, while 10- μ F capacitors and a 1-M Ω R_{COM} resistor shows 92 dB of CMRR.



图 48. CMRR Degradation Due to a 5% Mismatch in AC-Coupling Capacitors

8.1.5 Supply Divider Capacitive Loading

The VMID(OUT) pin of the INA165x is stable with capacitive loads up to 150 pF. An isolation resistor (R_{ISO} in 图 49), must be used if capacitive loads larger than 150 pF are connected to the VMID(OUT) pin. 图 49 shows the recommended configuration of an isolation resistor in series with the capacitive load. The REF pins of the INA1650 must connect directly to the VMID(OUT) pin before the isolation resistor. Any resistance placed between the VMID(OUT) pin and the reference pins degrades the CMRR of the device. 图 50 shows the recommended value for the isolation resistor for increasing capacitive loads.

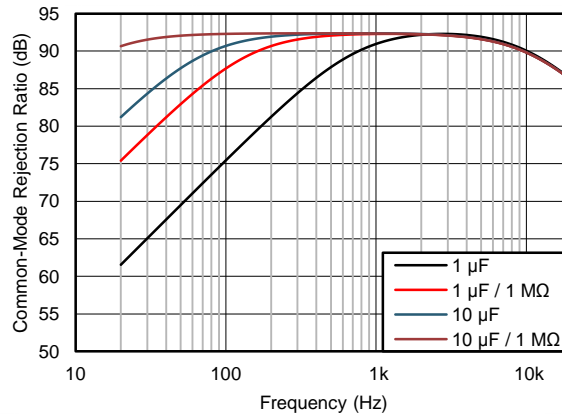
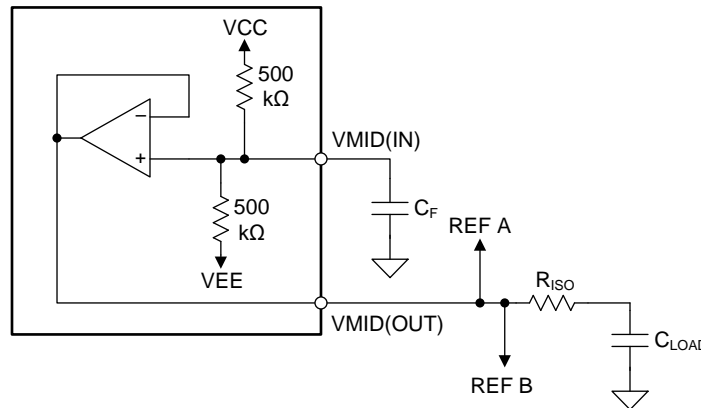

Copyright © 2016, Texas Instruments Incorporated

图 49. Place an Isolation Resistor Between the VMID(OUT) Pin and Large Capacitive Loads

Application Information (接下页)



图 50. Recommended Isolation Resistor Value vs Capacitive Load

8.2 Typical Applications

The low noise and distortion of the INA165x make these devices an excellent choice for a variety of applications in professional and consumer audio products. However, these same performance metrics make the INA165x useful for industrial, test and measurement, and data-acquisition applications. The examples shown here are possible applications where the INA165x provide exceptional performance.

8.2.1 Line Receiver for Differential Audio Signals in a Split-Supply System

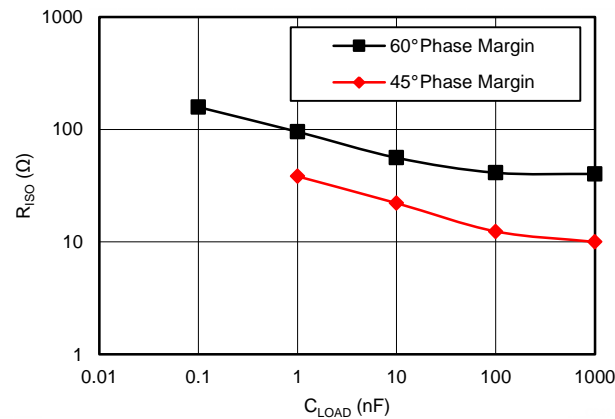
The INA165x devices are designed to require a minimum number of external components to achieve data sheet-level performance in audio line-receiver applications. 图 51 shows the INA1650 used as a differential audio line receiver in split-supply systems that are common in professional audio applications. The line receiver recovers a differential audio signal which may have been affected by significant common-mode noise.

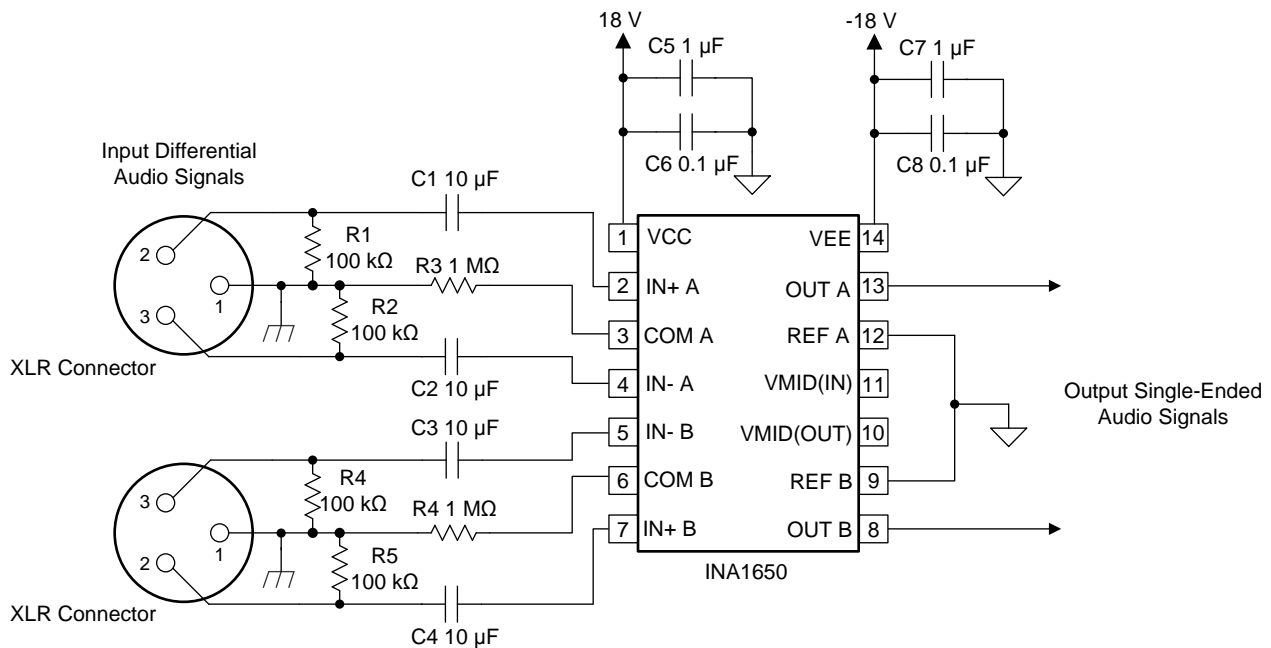

Copyright © 2016, Texas Instruments Incorporated

图 51. INA1650 Used as a Line Receiver for Differential Audio Signals in a Split-Supply System

Typical Applications (接下页)

8.2.1.1 Design Requirements

- Power Supply Voltage: ± 18 V
- Frequency Response: < 0.1 dB deviation from 20 Hz to 20 kHz
- Common-Mode Rejection Ratio: > 80 dB at 1 kHz
- THD+N: < -100 dB (4-dBu input signal, 1-kHz fundamental, 90-kHz measurement bandwidth)

8.2.1.2 Detailed Design Procedure

The passive components shown in [图 51](#) are selected using the information given in the [Application Information](#) and [Layout Guidelines](#) sections. All 10- μ F input AC-coupling capacitors (C1, C2, C3, and C4) maximize the CMRR performance at low frequency, as shown in [图 48](#). The high-pass corner frequency for input signals meets the design requirement for frequency response, as [公式 6](#) shows:

$$F_C = \frac{1}{2 \cdot \pi \cdot R_{IN} \cdot C_{IN}} = \frac{1}{2 \cdot \pi \cdot (500 \text{ k}\Omega) \cdot (10 \text{ }\mu\text{F})} = 0.032 \text{ Hz} \quad (6)$$

1-M Ω R_{COM} resistors (R3 and R4) further improve CMRR performance at low frequency. Resistors R1, R2, R4, and R5 provide a discharge pathway for the AC-coupling capacitors in the event that audio equipment with a DC offset voltage is connected to the inputs of the circuit. These resistors are optional and may degrade the CMRR performance with mismatches in source impedance. Finally, capacitors C5, C6, C7, and C8 provide a low-impedance pathway for power supply noise to pass to ground rather than interfering with the audio signal. No connection is necessary on the $V_{MID(IN)}$ and $V_{MID(OUT)}$ pins because the supply-divider circuit is not used in this particular application.

8.2.1.3 Application Curves

[图 52](#) through [图 57](#) illustrate the measured performance of the line receiver circuit. [图 52](#) shows the measured frequency response. The gain of the circuit is 0 dB as expected with 0.1-dB magnitude variation at 10 Hz. The measured CMRR of the circuit ([图 53](#)) at 1 kHz equals 94 dB without any source impedance mismatch. Adding a 10- Ω source impedance mismatch degrades the CMRR at 1 kHz to 92 dB. The high-frequency degradation of CMRR shown in [图 53](#) for the 10- Ω source impedance mismatch cases is due to the capacitance of the cables used for the measurement. The total harmonic distortion plus noise (THD+N) is plotted over frequency in [图 54](#). For a 4-dBu (1.23 V_{RMS}) input signal level, the THD+N remains flat at -101.6 dB (0.0008%) over the measured frequency range. Increasing the signal level to 22 dBu further decreases the THD+N to -115.2 dB (0.00017%) at 1 kHz, but the THD+N rises above 7 kHz. Measuring the THD+N vs Output Amplitude ([图 55](#)) at 1 kHz shows a constant downward slope until the noise floor of the audio analyzer is reached at 5 V_{RMS} . The constant downward slope indicates that noise from the device dominates THD+N at this frequency instead of distortion harmonics. [图 56](#) and [图 57](#) confirm this conclusion. For a 4-dBu signal level, the second harmonic is barely visible above the noise floor at -140 dBu. Increasing the signal level to 22 dBu produces distortion harmonics above the noise floor. The largest harmonic in this case is the second at -111.2 dBu, or -133.2 dB relative to the fundamental.

Typical Applications (接下页)

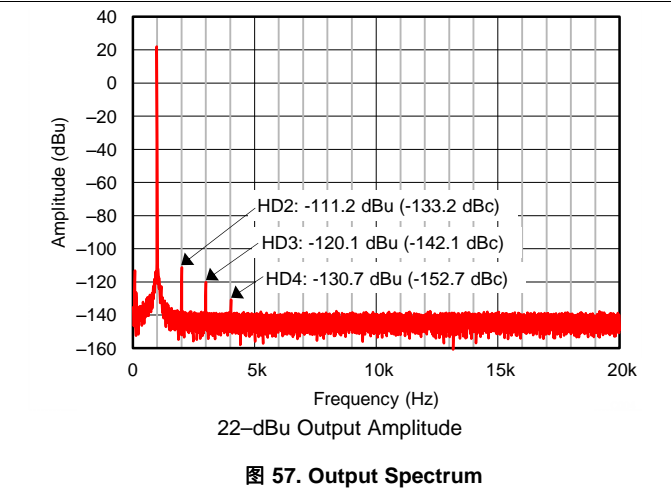
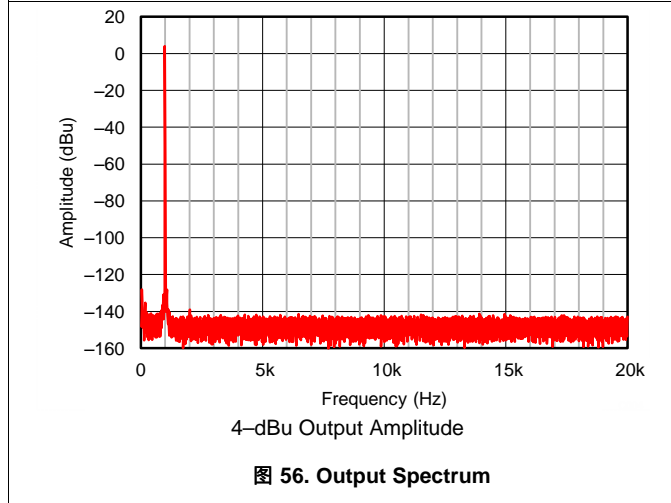
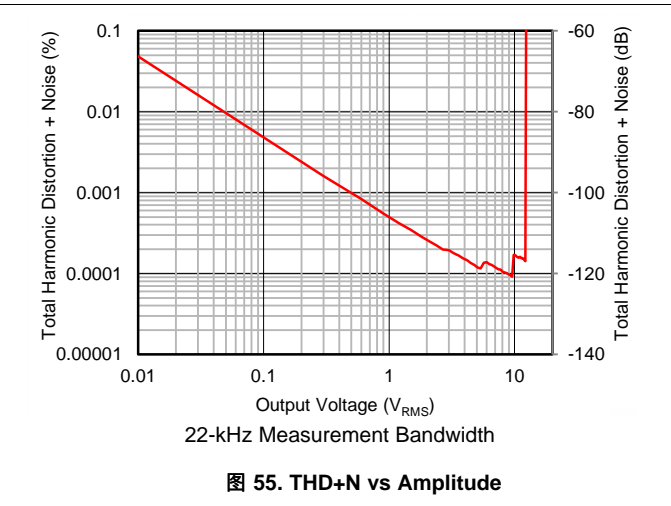
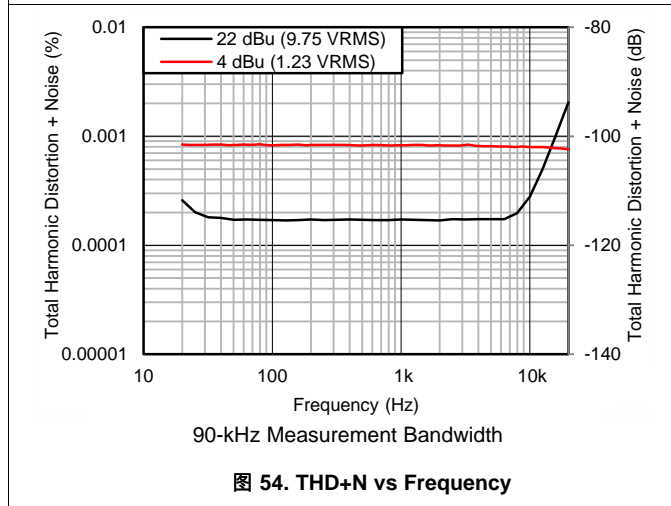
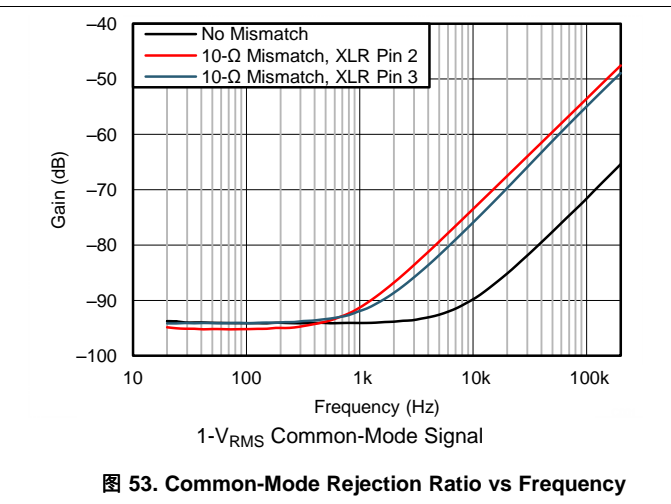
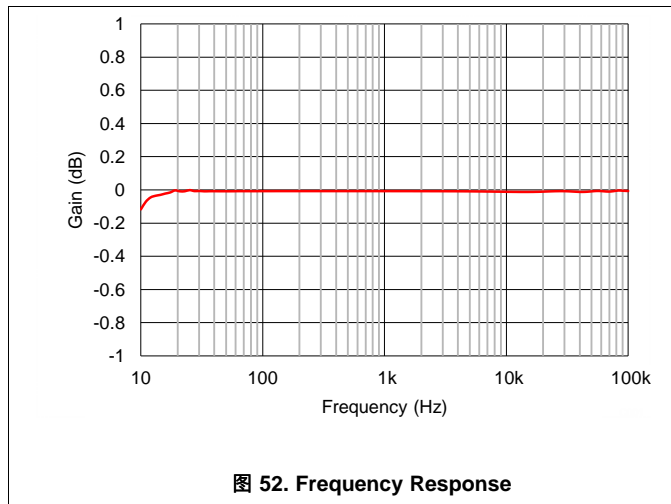

Typical Applications (接下页)

8.2.2 Differential Line Receiver for Single-Supply Applications

The INA1650 can simply operate in single-supply applications by connecting the COM and REF pins to the output of the internal supply divider.

($V_{MID(OUT)}$). Adding a 1- μF capacitor to the $V_{MID(IN)}$ pin to filters noise from the power supply and the internal voltage divider.

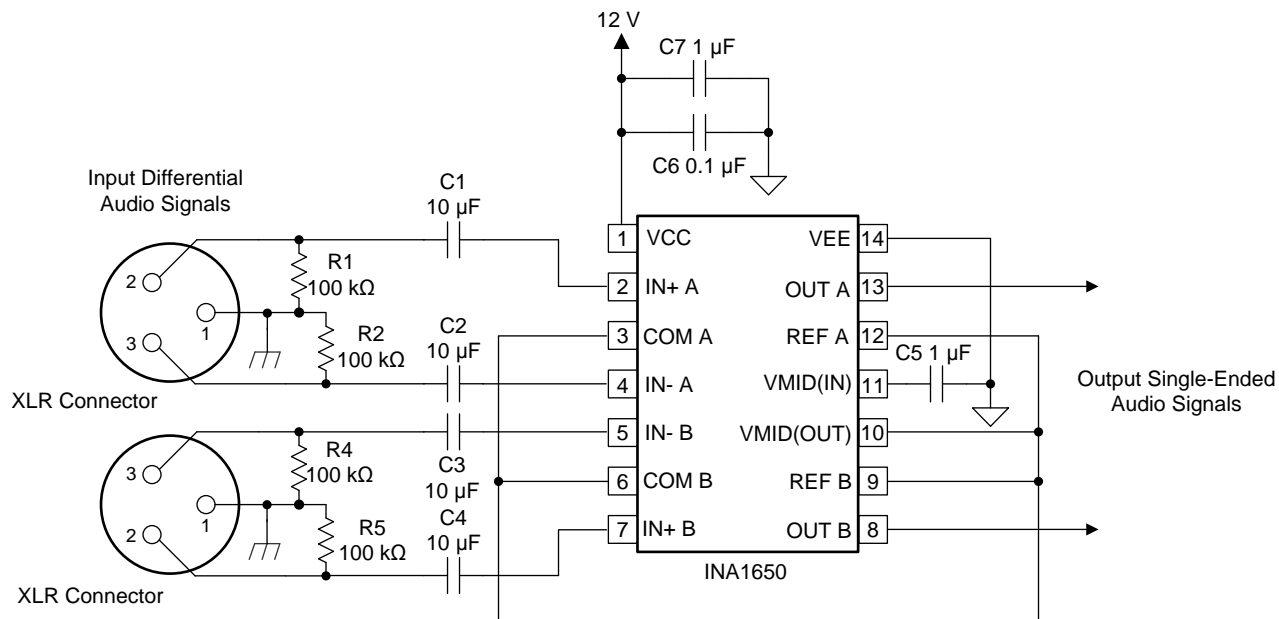

Copyright © 2016, Texas Instruments Incorporated

图 58. Differential Line Receiver for Single-Supply Applications

Typical Applications (接下页)
8.2.3 Floating Single-Ended Input Line Receiver for Ground Loop Noise Reduction

Ground loops commonly form in audio systems where the equipment is interconnected with coaxial cables, which introduces significant common-mode noise. If the sheath of the coaxial cable is connected to the equipment chassis and safety ground, a ground loop forms, which includes the main electrical wiring and the audio signal path. The INA165x can break these ground loops by floating the sheath of the coaxial cable through resistors (R3 and R4 in [图 59](#)) so ground noise appears at the inputs of the INA165x as a common-mode signal. Capacitors C8 and C9 provide a high-frequency pathway to ground for radio frequency interference (RFI). A transient voltage suppressor (TVS) connected between the coaxial sheath and the chassis ground is shown in [图 59](#). This TVS protects the inputs of the INA165x in the event of an electrostatic discharge to the signal input.

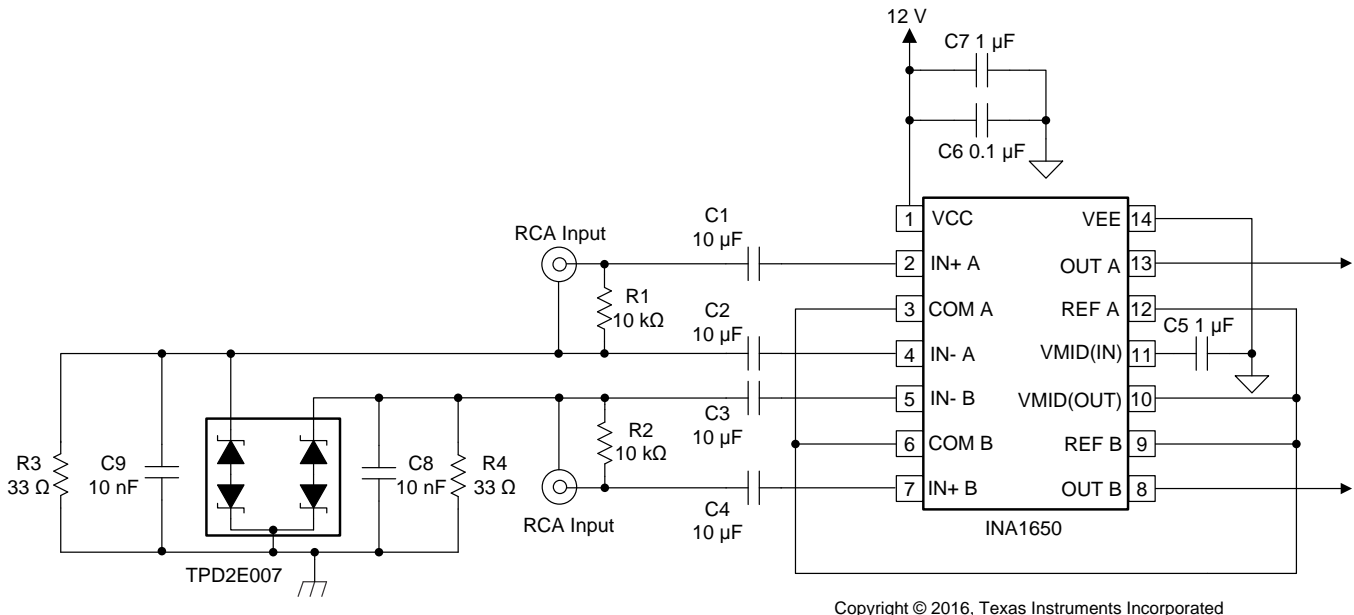
图 59. Ground Loop Isolation in Single-Ended Systems

Typical Applications (接下页)

8.2.4 Floating Single-Ended Input Line Receiver With Differential Outputs

The application in 图 59 can be further extended to include differential outputs, which are necessary for audio ADCs and many Class-D amplifier devices. 图 60 shows the addition of an OPA1688 audio operational amplifier to the outputs of the INA1650 that convert the single-ended outputs to differential outputs.



图 60. Single-Ended Line-Receiver Circuit With Differential Outputs

8.2.5 TRS Audio Interface in Single-Supply Applications

The INA1650 can be used for auxiliary audio inputs which may use a tip-ring-sleeve (TRS) connector where both audio channels share a common ground connection. 图 61 shows the INA1650 configured as a line receiver for a TRS interface to remove common-mode noise on the sleeve connection.

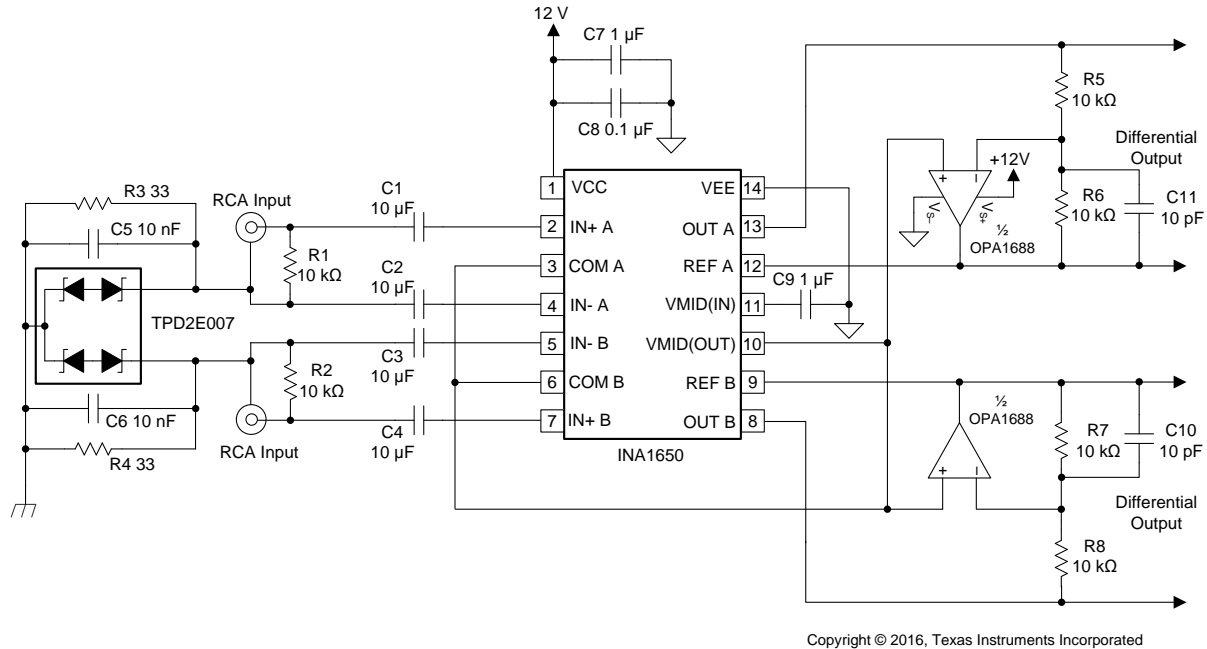

图 61. TRS Audio Interface in Single-Supply Applications

Typical Applications (接下页)
8.2.6 Differential Line Driver With Single-Ended Input

The INA1650 can be employed in line-driver applications (图 62) where the precision matched internal resistor networks are useful in converting a single-ended signal to a balanced signal. Resistors R1 and R4 (shown in 图 62) isolate the large cable capacitance from the outputs of the INA1650 to maintain stability. TI recommends AC-coupling capacitors C1 and C2 since the DC voltages of the connected equipment may be unknown. Resistors R2 and R3 dissipate any charge collected on the capacitors due to connecting equipment with a DC voltage present.

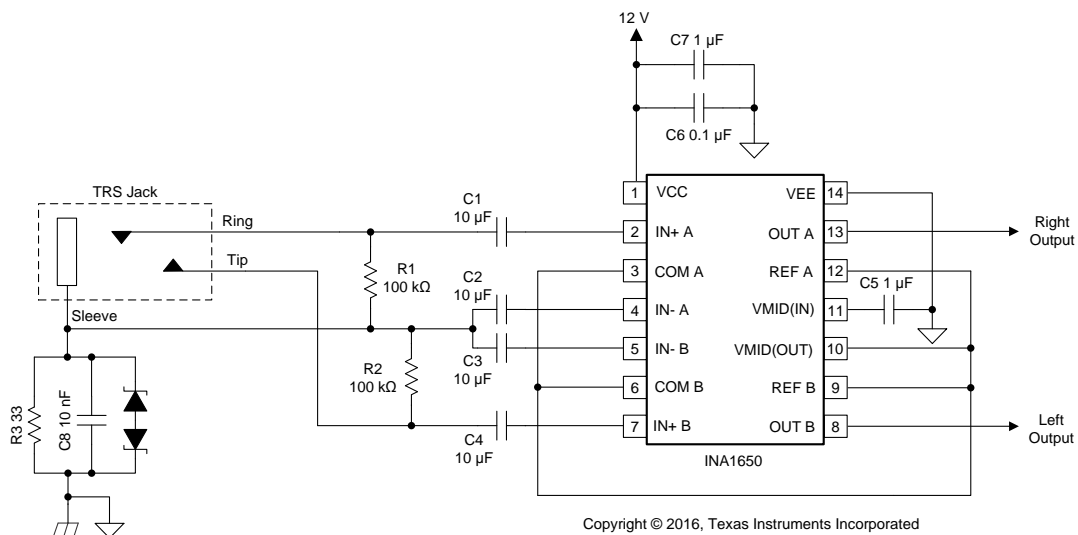
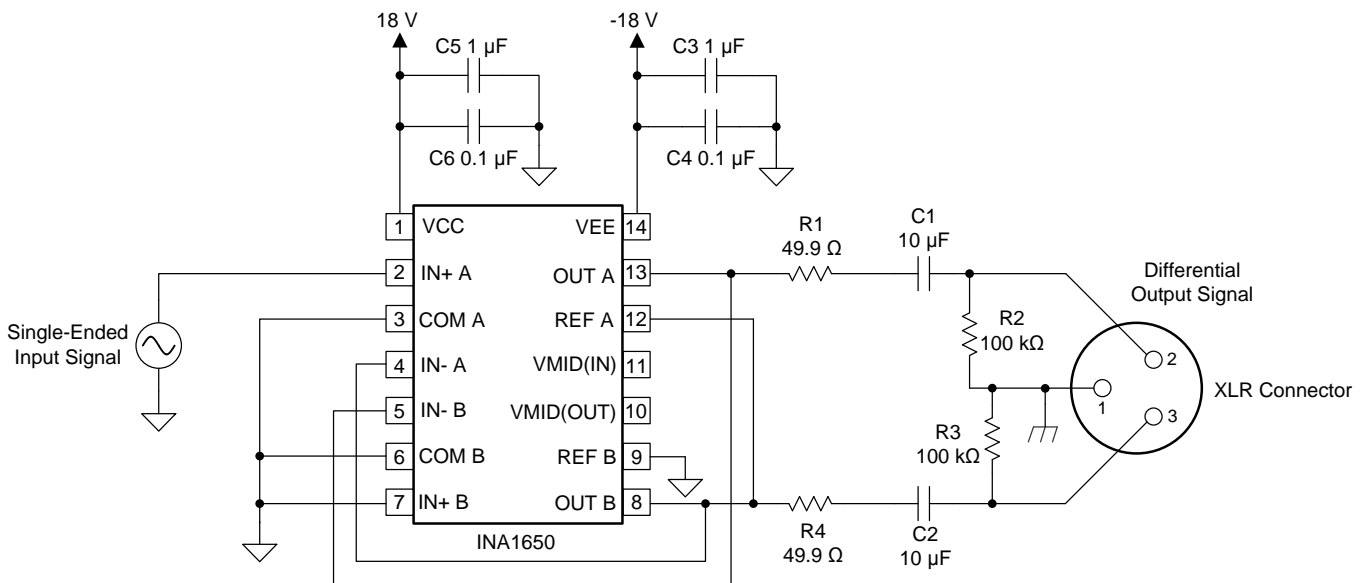

Copyright © 2016, Texas Instruments Incorporated

图 62. INA1650 Used as a Balanced Audio Line Driver

9 Power Supply Recommendations

The INA165x operates from $\pm 2.25\text{-V}$ to $\pm 18\text{-V}$ supplies while maintaining excellent performance. However, some applications do not require equal positive and negative output voltage swing. With the INA165x, power-supply voltages do not need to be equal. For example, the positive supply can be set to 25 V with the negative supply at -5 V .

10 Layout

10.1 Layout Guidelines

For best operational performance of the device, use good printed circuit board (PCB) layout practices, including:

- Connect low-ESR, 1.0- μF and 0.1- μF ceramic bypass capacitors between each supply pin and ground, placed as close to the device as possible. Connecting bypass capacitors only from $V+$ to ground is acceptable in single-supply applications. Noise can propagate into analog circuitry through the power pins of this device. The bypass capacitors reduce the coupled noise by providing low-impedance pathways to ground.
- Connect the device REF pins to a low-impedance, low-noise, system reference point (such as an analog ground or the VMID(OUT) pin) with the shortest trace possible.
- Place the external components as close to the device as possible, as shown in [图 63](#) and [图 64](#).
- Use ground pours and planes to shield input signal traces and minimize additional noise introduced into the signal path.
- Keep the length of input traces equal and as short as possible. Route the input traces as a differential pair with as minimal spacing between them as possible.

10.2 Layout Examples

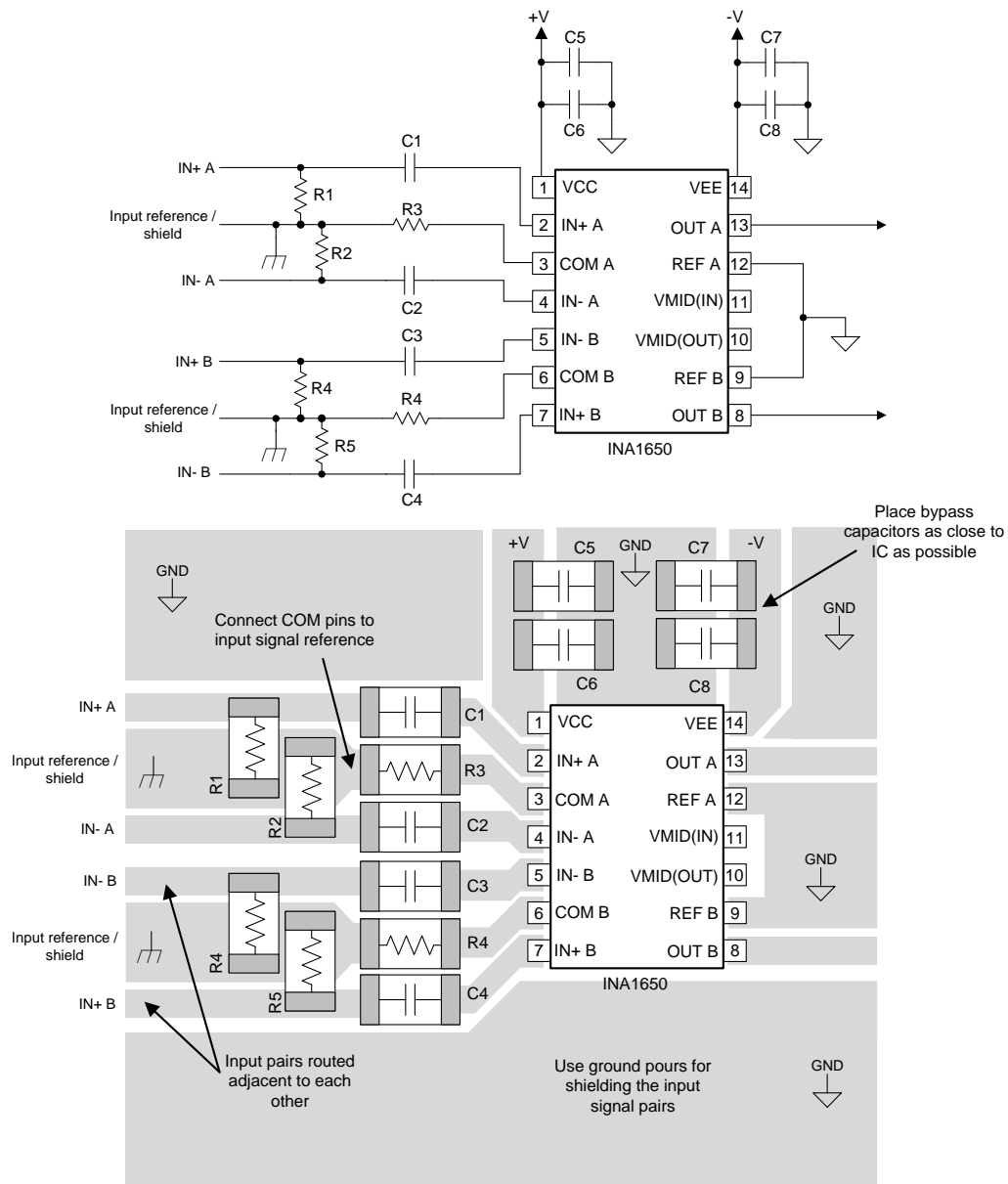

Copyright © 2016, Texas Instruments Incorporated

图 63. Layout Example for a Dual-Supply Line Receiver

Layout Examples (接下页)

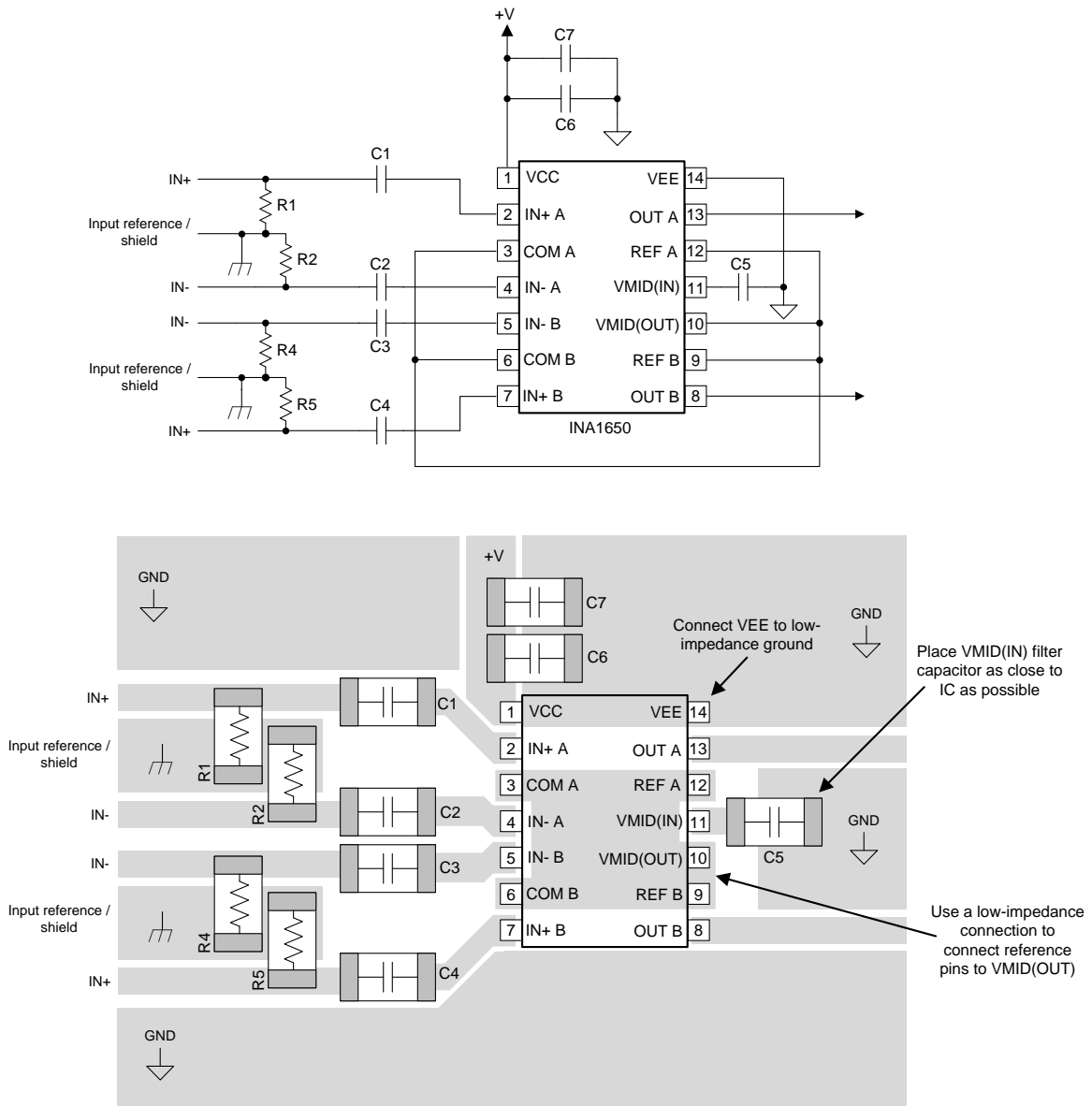

Copyright © 2016, Texas Instruments Incorporated

图 64. Layout Example for a Single-Supply Line Receiver

11 器件和文档支持

11.1 器件支持

11.1.1 开发支持

11.1.1.1 TINA-TI™ (免费软件下载)

TINA™是一款简单、功能强大且易于使用的电路仿真程序，此程序基于 SPICE 引擎。TINA-TI 是 TINA 软件的一款免费全功能版本，除了一系列无源和有源模型外，此版本软件还预先载入了一个宏模型库。TINA-TI 提供所有传统的 SPICE 直流、瞬态和频域分析，以及其他设计功能。

TINA-TI 可从 WEBENCH® 设计中心[免费下载](#)，它提供全面的后续处理能力，使得用户能够以多种方式形成结果。虚拟仪器提供选择输入波形和探测电路节点、电压和波形的功能，从而创建一个动态的快速入门工具。

注

这些文件需要安装 TINA 软件（由 DesignSoft™提供）或者 TINA-TI 软件。请从 [TINA-TI 文件夹](#) 中下载免费的 TINA-TI 软件。

11.1.1.2 TI 高精度设计

欲获取 TI 高精度设计，请访问 <http://www.ti.com.cn/ww/analog/precision-designs/>。TI 高精度设计是由 TI 公司高精度模拟应用专家创建的模拟解决方案，提供了许多实用电路的工作原理、组件选择、仿真、完整印刷电路板 (PCB) 电路原理图和布局布线、物料清单以及性能测量结果。

11.2 文档支持

11.2.1 相关文档

请参阅如下相关文档：

[《电路板布局布线技巧》](#)

11.3 相关链接

[表 1](#) 列出了快速访问链接。类别包括技术文档、支持和社区资源、工具与软件，以及立即订购快速访问。

表 1. 相关链接

器件	产品文件夹	立即订购	技术文档	工具与软件	支持和社区
INA1650	请单击此处	请单击此处	请单击此处	请单击此处	请单击此处
INA1651	请单击此处	请单击此处	请单击此处	请单击此处	请单击此处

11.4 接收文档更新通知

要接收文档更新通知，请导航至 TI.com.cn 上的器件产品文件夹。单击右上角的 [通知我进行注册](#)，即可每周接收产品信息更改摘要。有关更改的详细信息，请查看任何已修订文档中包含的修订历史记录。

11.5 社区资源

下列链接提供到 TI 社区资源的连接。链接的内容由各个分销商“按照原样”提供。这些内容并不构成 TI 技术规范，并且不一定反映 TI 的观点；请参阅 TI 的 [《使用条款》](#)。

TI E2E™ 在线社区 [TI 的工程师对工程师 \(E2E\) 社区](#)。此社区的创建目的在于促进工程师之间的协作。在 e2e.ti.com 中，您可以咨询问题、分享知识、拓展思路并与同行工程师一道帮助解决问题。

设计支持 [TI 参考设计支持](#) 可帮助您快速查找有帮助的 E2E 论坛、设计支持工具以及技术支持的联系信息。

11.6 商标

SoundPlus, E2E are trademarks of Texas Instruments.

TINA-TI is a trademark of Texas Instruments, Inc and DesignSoft, Inc.

TINA, DesignSoft are trademarks of DesignSoft, Inc.

All other trademarks are the property of their respective owners.

11.7 静电放电警告



ESD 可能会损坏该集成电路。德州仪器 (TI) 建议通过适当的预防措施处理所有集成电路。如果不遵守正确的处理措施和安装程序，可能会损坏集成电路。

ESD 的损坏小至导致微小的性能降级，大至整个器件故障。精密的集成电路可能更容易受到损坏，这是因为非常细微的参数更改都可能会导致器件与其发布的规格不相符。

11.8 术语表

[SLYZ022](#) — *TI 术语表*。

这份术语表列出并解释术语、缩写和定义。

12 机械、封装和可订购信息

以下页面包含机械、封装和可订购信息。这些信息是指定器件的最新可用数据。数据如有变更，恕不另行通知，且不会对此文档进行修订。如需获取此数据表的浏览器版本，请查阅左侧的导航栏。

PACKAGING INFORMATION

Orderable Device	Status (1)	Package Type	Package Drawing	Pins	Package Qty	Eco Plan (2)	Lead finish/ Ball material (6)	MSL Peak Temp (3)	Op Temp (°C)	Device Marking (4/5)	Samples
INA1650IPW	ACTIVE	TSSOP	PW	14	90	RoHS & Green	NIPDAU	Level-2-260C-1 YEAR	-40 to 125	IN1650C	Samples
INA1650IPWR	ACTIVE	TSSOP	PW	14	2000	RoHS & Green	NIPDAU	Level-2-260C-1 YEAR	-40 to 125	IN1650C	Samples
INA1651IPW	ACTIVE	TSSOP	PW	14	90	RoHS & Green	NIPDAU	Level-2-260C-1 YEAR	-40 to 125	INA1651	Samples
INA1651IPWR	ACTIVE	TSSOP	PW	14	2000	RoHS & Green	NIPDAU	Level-2-260C-1 YEAR	-40 to 125	INA1651	Samples

(1) The marketing status values are defined as follows:

ACTIVE: Product device recommended for new designs.

LIFEBUY: TI has announced that the device will be discontinued, and a lifetime-buy period is in effect.

NRND: Not recommended for new designs. Device is in production to support existing customers, but TI does not recommend using this part in a new design.

PREVIEW: Device has been announced but is not in production. Samples may or may not be available.

OBSOLETE: TI has discontinued the production of the device.

(2) **RoHS:** TI defines "RoHS" to mean semiconductor products that are compliant with the current EU RoHS requirements for all 10 RoHS substances, including the requirement that RoHS substance do not exceed 0.1% by weight in homogeneous materials. Where designed to be soldered at high temperatures, "RoHS" products are suitable for use in specified lead-free processes. TI may reference these types of products as "Pb-Free".

RoHS Exempt: TI defines "RoHS Exempt" to mean products that contain lead but are compliant with EU RoHS pursuant to a specific EU RoHS exemption.

Green: TI defines "Green" to mean the content of Chlorine (Cl) and Bromine (Br) based flame retardants meet JS709B low halogen requirements of <=1000ppm threshold. Antimony trioxide based flame retardants must also meet the <=1000ppm threshold requirement.

(3) MSL, Peak Temp. - The Moisture Sensitivity Level rating according to the JEDEC industry standard classifications, and peak solder temperature.

(4) There may be additional marking, which relates to the logo, the lot trace code information, or the environmental category on the device.

(5) Multiple Device Markings will be inside parentheses. Only one Device Marking contained in parentheses and separated by a "-" will appear on a device. If a line is indented then it is a continuation of the previous line and the two combined represent the entire Device Marking for that device.

(6) Lead finish/Ball material - Orderable Devices may have multiple material finish options. Finish options are separated by a vertical ruled line. Lead finish/Ball material values may wrap to two lines if the finish value exceeds the maximum column width.

Important Information and Disclaimer:The information provided on this page represents TI's knowledge and belief as of the date that it is provided. TI bases its knowledge and belief on information provided by third parties, and makes no representation or warranty as to the accuracy of such information. Efforts are underway to better integrate information from third parties. TI has taken and

continues to take reasonable steps to provide representative and accurate information but may not have conducted destructive testing or chemical analysis on incoming materials and chemicals. TI and TI suppliers consider certain information to be proprietary, and thus CAS numbers and other limited information may not be available for release.

In no event shall TI's liability arising out of such information exceed the total purchase price of the TI part(s) at issue in this document sold by TI to Customer on an annual basis.

TAPE AND REEL INFORMATION

QUADRANT ASSIGNMENTS FOR PIN 1 ORIENTATION IN TAPE

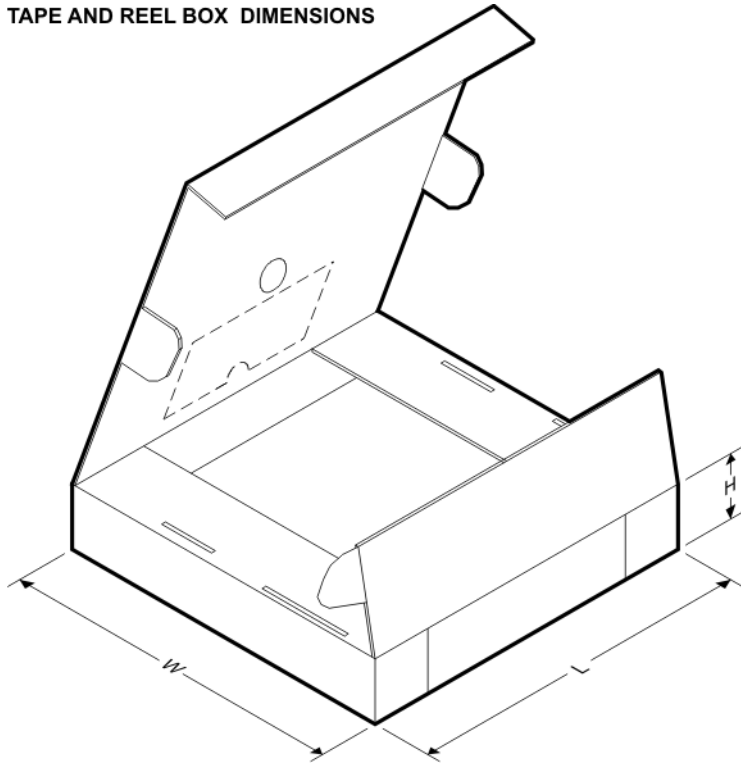

*All dimensions are nominal

Device	Package Type	Package Drawing	Pins	SPQ	Reel Diameter (mm)	Reel Width W1 (mm)	A0 (mm)	B0 (mm)	K0 (mm)	P1 (mm)	W (mm)	Pin1 Quadrant
INA1650IPWR	TSSOP	PW	14	2000	330.0	12.4	6.9	5.6	1.6	8.0	12.0	Q1
INA1651IPWR	TSSOP	PW	14	2000	330.0	12.4	6.9	5.6	1.6	8.0	12.0	Q1

TAPE AND REEL BOX DIMENSIONS

*All dimensions are nominal

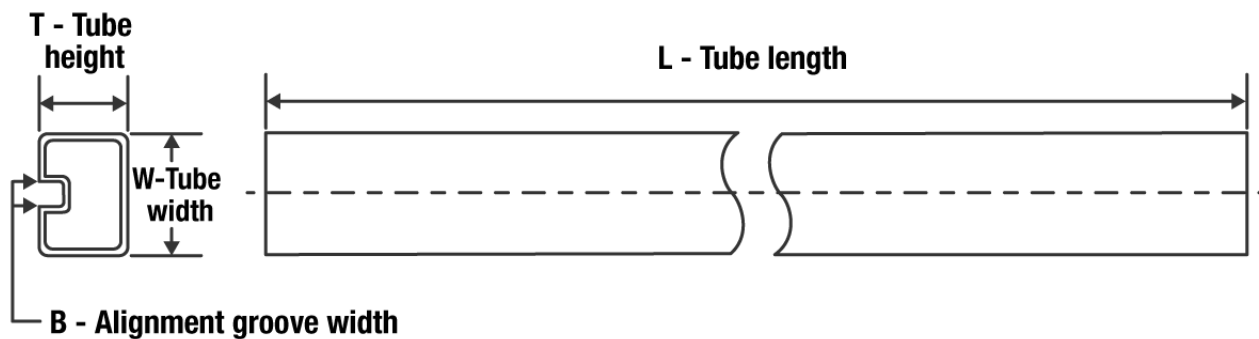
Device	Package Type	Package Drawing	Pins	SPQ	Length (mm)	Width (mm)	Height (mm)
INA1650IPWR	TSSOP	PW	14	2000	367.0	367.0	35.0
INA1651IPWR	TSSOP	PW	14	2000	367.0	367.0	35.0

TUBE

*All dimensions are nominal

Device	Package Name	Package Type	Pins	SPQ	L (mm)	W (mm)	T (μm)	B (mm)
INA1650IPW	PW	TSSOP	14	90	530	10.2	3600	3.5
INA1651IPW	PW	TSSOP	14	90	530	10.2	3600	3.5

PW (R-PDSO-G14)

PLASTIC SMALL OUTLINE



4211284-2/G 08/15

- NOTES:
- All linear dimensions are in millimeters.
 - This drawing is subject to change without notice.
 - Publication IPC-7351 is recommended for alternate designs.
 - Laser cutting apertures with trapezoidal walls and also rounding corners will offer better paste release. Customers should contact their board assembly site for stencil design recommendations. Refer to IPC-7525 for other stencil recommendations.
 - Customers should contact their board fabrication site for solder mask tolerances between and around signal pads.

重要声明和免责声明

TI“按原样”提供技术和可靠性数据（包括数据表）、设计资源（包括参考设计）、应用或其他设计建议、网络工具、安全信息和其他资源，不保证没有瑕疵且不做任何明示或暗示的担保，包括但不限于对适销性、某特定用途方面的适用性或不侵犯任何第三方知识产权的暗示担保。

这些资源可供使用 TI 产品进行设计的熟练开发人员使用。您将自行承担以下全部责任：(1) 针对您的应用选择合适的 TI 产品，(2) 设计、验证并测试您的应用，(3) 确保您的应用满足相应标准以及任何其他功能安全、信息安全、监管或其他要求。

这些资源如有变更，恕不另行通知。TI 授权您仅可将这些资源用于研发本资源所述的 TI 产品的应用。严禁对这些资源进行其他复制或展示。您无权使用任何其他 TI 知识产权或任何第三方知识产权。您应全额赔偿因在这些资源的使用中对 TI 及其代表造成的任何索赔、损害、成本、损失和债务，TI 对此概不负责。

TI 提供的产品受 [TI 的销售条款](#) 或 [ti.com](#) 上其他适用条款/TI 产品随附的其他适用条款的约束。TI 提供这些资源并不会扩展或以其他方式更改 TI 针对 TI 产品发布的适用的担保或担保免责声明。

TI 反对并拒绝您可能提出的任何其他或不同的条款。

邮寄地址：Texas Instruments, Post Office Box 655303, Dallas, Texas 75265

Copyright © 2022，德州仪器 (TI) 公司