

# INA240-Q1 符合 AEC-Q100 标准 -4V 至 80V、具有增强型 PWM 抑制的双向、超精密电流检测放大器

## 1 特性

- 符合面向汽车应用的 AEC-Q100 标准
  - 温度等级 1：-40°C 至 +125°C 环境温度范围
  - 温度等级 0：-40°C 至 +150°C 环境运行温度范围
  - HBM ESD 分类等级 H2
  - CDM ESD 分类等级 C5
- 提供功能安全
  - 可帮助进行功能安全系统设计的文档
- 增强型 PWM 抑制
- 出色的共模抑制比 (CMRR)：
  - 132dB DC CMRR
  - 93dB AC CMRR (50kHz 时)
- 宽共模范围：-4V 至 80V
- 精度：
  - 增益误差：0.20% (最大值)，2.5ppm/°C (最大漂移)
  - 失调电压：±25μV (最大值)，250nV/°C (最大漂移)
- 可用的增益：
  - INA240A1-Q1：20V/V
  - INA240A2-Q1：50V/V
  - INA240A3-Q1：100V/V
  - INA240A4-Q1：200V/V

## 2 应用

- 电子动力转向
- 稳定性和牵引控制
- 电机和传动器控制
- 螺线管和阀门控制

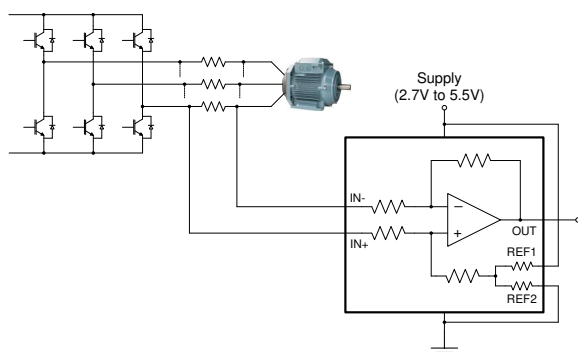

典型应用

## 3 说明

INA240-Q1 器件是一款经汽车认证的电压输出、电流检测放大器，具有增强型 PWM 抑制功能，可在独立于电源电压的 -4V 至 80V 宽共模电压范围内检测分流器电阻上的压降。负共模电压允许器件的工作电压低于接地电压，从而适应典型螺线管应用的反激周期。增强型 PWM 抑制功能可为使用脉宽调制 (PWM) 信号的系 (例如，电机驱动和螺线管控制系统) 中的较大共模瞬变 ( $\Delta V/\Delta t$ ) 提供高水平的抑制。凭借该功能，可精确测量电流，而不会使输出电压产生较大的瞬变及相应的恢复纹波。

该器件由 2.7V 至 5.5V 的单电源供电运行，消耗的最大电源电流为 2.4mA。共有四种固定增益可供选择：20V/V、50V/V、100V/V 以及 200V/V。零漂移架构的低偏移使得该器件能够在分流器上的最大压降低至 10mV (满量程) 的情况下进行电流感应。1 级版本具有额定的扩展工作温度范围 (-40°C 至 +125°C)，并且采用 8 引脚 TSSOP 和 8 引脚 SOIC 封装。0 级版本具有额定的扩展工作温度范围 (-40°C 至 +150°C)，并且采用 8 引脚 SOIC 封装。

### 器件信息(1)

器件型号	封装	封装尺寸 (标称值)
INA240-Q1	TSSOP (8)	3.00mm × 4.40mm
	SOIC (8)	4.90mm × 3.91mm

(1) 如需了解所有可用封装，请参阅数据表末尾的封装选项附录。

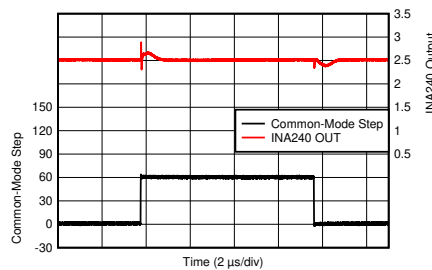

增强型 PWM 抑制

D004



## Table of Contents

<b>1 特性</b> .....	1	<b>9 Application and Implementation</b> .....	19
<b>2 应用</b> .....	1	9.1 Application Information.....	19
<b>3 说明</b> .....	1	9.2 Typical Applications.....	21
<b>4 Revision History</b> .....	2	9.3 What to Do and What Not to Do.....	24
<b>5 Device Comparison</b> .....	3	<b>10 Power Supply Recommendations</b> .....	24
<b>6 Pin Configuration and Functions</b> .....	3	10.1 Power Supply Decoupling.....	24
<b>7 Specifications</b> .....	4	<b>11 Layout</b> .....	25
7.1 Absolute Maximum Ratings.....	4	11.1 Layout Guidelines.....	25
7.2 ESD Ratings.....	4	11.2 Layout Example.....	25
7.3 Recommended Operating Conditions.....	4	<b>12 Device and Documentation Support</b> .....	27
7.4 Thermal Information.....	4	12.1 Documentation Support.....	27
7.5 Electrical Characteristics.....	5	12.2 接收文档更新通知.....	27
7.6 Typical Characteristics.....	7	12.3 支持资源.....	27
<b>8 Detailed Description</b> .....	11	12.4 Trademarks.....	27
8.1 Overview.....	11	12.5 Electrostatic Discharge Caution.....	27
8.2 Functional Block Diagram.....	11	12.6 术语表.....	27
8.3 Feature Description.....	11	<b>13 Mechanical, Packaging, and Orderable Information</b> .....	27
8.4 Device Functional Modes.....	13		

## 4 Revision History

注：以前版本的页码可能与当前版本的页码不同

<b>Changes from Revision D (April 2020) to Revision E (December 2021)</b>	<b>Page</b>
• 将“器件信息”表中的 SOIC 封装尺寸从 4.00mm × 3.91mm 更改为 4.90mm × 3.91mm.....	1
• Added <i>or left unconnected</i> to the NC pin in the Pin Functions table .....	3
• Changed the reference design guide link in the <i>Related Documentation</i> section.....	27
<b>Changes from Revision C (November 2018) to Revision D (April 2020)</b>	<b>Page</b>
• 添加了“提供功能安全型”信息.....	1
<b>Changes from Revision B (December 2017) to Revision C (November 2018)</b>	<b>Page</b>
• 将文档状态从“混合状态”更改为“量产数据”.....	1
• 向数据表添加了温度等级 0 器件.....	1
• 将 TSSOP 封装状态从预发布更改为量产数据.....	1
• Deleted package preview note from 8-pin TSSOP package pinout drawing in <i>Pin Configuration and Functions</i> section.....	3
• Deleted package preview note from <i>Thermal Information</i> table .....	4
<b>Changes from Revision A (December 2016) to Revision B (December 2017)</b>	<b>Page</b>
• 将文档状态从“产品预发布”更改为“混合状态”.....	1
• 添加了 <i>说明 (续)</i> 部分.....	1
• 向 8 引脚 TSSOP 封装添加了预发布标签.....	1
• Changed y-axis values in 图 7-15 .....	7
• Added 图 11-2 .....	25
<b>Changes from Revision * (August 2016) to Revision A (December 2016)</b>	<b>Page</b>
• 为 INA240-Q1 0 级和 1 级器件添加了 8 引脚 D (SOIC) 封装.....	1
• Added thermal values for the D (SOIC) package in the <i>Thermal Information</i> table .....	4

## 5 Device Comparison

**表 5-1. Device Comparison**

PRODUCT	GAIN (V/V)
INA240A1-Q1	20
INA240A2-Q1	50
INA240A3-Q1	100
INA240A4-Q1	200

## 6 Pin Configuration and Functions

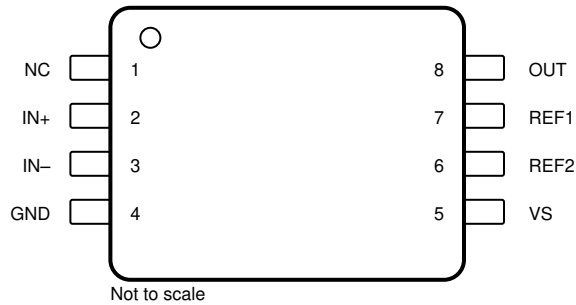

NC- no internal connection

For INA240-Q1, Grade 1 only

**图 6-1. INA240-Q1 PW Package 8-Pin TSSOP Top View**

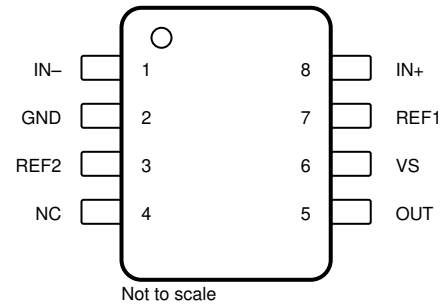

NC- no internal connection

For INA240-Q1, Grade 0 and Grade 1

**图 6-2. INA240-Q1 D Package 8-Pin SOIC Top View**

**表 6-1. Pin Functions**

NAME	PIN		I/O	DESCRIPTION
	PW (TSSOP)	D (SOIC)		
GND	4	2	Analog	Ground
IN-	3	1	Analog input	Connect to load side of shunt resistor
IN+	2	8	Analog input	Connect to supply side of shunt resistor
NC	1	4	—	Reserved. Connect to ground or leave floating
OUT	8	5	Analog output	Output voltage
REF1	7	7	Analog input	Reference 1 voltage. Connect to 0 V to VS; see the <a href="#">Adjusting the Output Midpoint With the Reference Pins</a> section for connection options
REF2	6	3	Analog input	Reference 2 voltage. Connect to 0 V to VS; see the <a href="#">Adjusting the Output Midpoint With the Reference Pins</a> section for connection options
VS	5	6	—	Power supply, 2.7 V to 5.5 V

## 7 Specifications

### 7.1 Absolute Maximum Ratings

over operating free-air temperature range (unless otherwise noted)<sup>(1)</sup>

		MIN	MAX	UNIT
Supply voltage			6	V
Analog inputs, $V_{IN+}$ , $V_{IN-}$ <sup>(2)</sup>	Differential ( $V_{IN+}$ ) – ( $V_{IN-}$ )	–80	80	V
	Common-mode	–6	90	V
REF1, REF2, NC inputs		GND – 0.3	$V_S + 0.3$	V
Output		GND – 0.3	$V_S + 0.3$	V
Operating free-air temperature, $T_A$		–55	150	°C
Junction temperature, $T_J$			150	°C
Storage temperature, $T_{stg}$		–65	150	°C

- (1) Stresses beyond those listed under *Absolute Maximum Ratings* may cause permanent damage to the device. These are stress ratings only, which do not imply functional operation of the device at these or any other conditions beyond those indicated under *Recommended Operating Conditions*. Exposure to absolute-maximum-rated conditions for extended periods may affect device reliability.
- (2)  $V_{IN+}$  and  $V_{IN-}$  are the voltages at the IN+ and IN– pins, respectively.

### 7.2 ESD Ratings

		VALUE	UNIT
$V_{(ESD)}$ Electrostatic discharge	Human-body model (HBM), per AEC Q100-002 <sup>(1)</sup>	±2000	V
	Charged-device model (CDM), per AEC Q100-011	±1000	

- (1) AEC Q100-002 indicates that HBM stressing shall be in accordance with the ANSI/ESDA/JEDEC JS-001 specification.

### 7.3 Recommended Operating Conditions

over operating free-air temperature range (unless otherwise noted)

		MIN	NOM	MAX	UNIT
$V_{CM}$	Common-mode input voltage	–4		80	V
$V_S$	Operating supply voltage	2.7		5.5	V
$T_A$	Operating free-air temperature	–40		125	°C
$T_A$	Operating free-air temperature, INA240A1EDRQ1, INA240A2EDRQ1, INA240A3EDRQ1, INA240A4EDRQ1	–40		150	°C

### 7.4 Thermal Information

THERMAL METRIC <sup>(1)</sup>	INA240-Q1		UNIT
	PW (TSSOP)	D (SOIC)	
	8 PINS	8 PINS	
$R_{\theta JA}$ Junction-to-ambient thermal resistance	149.1	113.5	°C/W
$R_{\theta JC(top)}$ Junction-to-case (top) thermal resistance	33.2	51.9	°C/W
$R_{\theta JB}$ Junction-to-board thermal resistance	78.4	57.8	°C/W
$\psi_{JT}$ Junction-to-top characterization parameter	1.5	10.2	°C/W
$\psi_{JB}$ Junction-to-board characterization parameter	76.4	56.9	°C/W

- (1) For more information about traditional and new thermal metrics, see the [Semiconductor and IC Package Thermal Metrics](#) application report.

## 7.5 Electrical Characteristics

at  $T_A = 25\text{ }^\circ\text{C}$ ,  $V_S = 5\text{ V}$ ,  $V_{\text{SENSE}} = V_{\text{IN}+} - V_{\text{IN}-}$ ,  $V_{\text{CM}} = 12\text{ V}$ , and  $V_{\text{REF}1} = V_{\text{REF}2} = V_S / 2$  (unless otherwise noted)

PARAMETER		TEST CONDITIONS	MIN	TYP	MAX	UNIT
<b>INPUT</b>						
$V_{\text{CM}}$	Common-mode input range	$V_{\text{IN}+} = -4\text{ V to } 80\text{ V}$ , $V_{\text{SENSE}} = 0\text{ mV}$ $T_A = -40\text{ }^\circ\text{C to } 125\text{ }^\circ\text{C}$	-4		80	V
		$T_A = -40\text{ }^\circ\text{C to } 150\text{ }^\circ\text{C}$ , INA240A1EDRQ1, INA240A2EDRQ1, INA240A3EDRQ1, INA240A4EDRQ1	-4		80	
CMRR	Common-mode rejection ratio	$V_{\text{IN}+} = -4\text{ V to } 80\text{ V}$ , $V_{\text{SENSE}} = 0\text{ mV}$ $T_A = -40\text{ }^\circ\text{C to } 125\text{ }^\circ\text{C}$	120	132		dB
		$T_A = -40\text{ }^\circ\text{C to } 150\text{ }^\circ\text{C}$ , INA240A1EDRQ1, INA240A2EDRQ1, INA240A3EDRQ1, INA240A4EDRQ1	120	132		
		$f = 50\text{ kHz}$		93		
$V_{\text{OS}}$	Offset voltage, input-referred	$V_{\text{SENSE}} = 0\text{ mV}$		$\pm 5$	$\pm 25$	$\mu\text{V}$
$dV_{\text{OS}}/dT$	Offset voltage drift	$V_{\text{SENSE}} = 0\text{ mV}$ , $T_A = -40\text{ }^\circ\text{C to } 125\text{ }^\circ\text{C}$ $T_A = -40\text{ }^\circ\text{C to } 150\text{ }^\circ\text{C}$ , INA240A1EDRQ1, INA240A2EDRQ1, INA240A3EDRQ1, INA240A4EDRQ1		$\pm 50$	$\pm 250$	$\text{nV}/^\circ\text{C}$
PSRR	Power-supply rejection ratio	$V_S = 2.7\text{ V to } 5.5\text{ V}$ , $V_{\text{SENSE}} = 0\text{ mV}$ $T_A = -40\text{ }^\circ\text{C to } 125\text{ }^\circ\text{C}$		$\pm 1$	$\pm 10$	$\mu\text{V}/\text{V}$
		$T_A = -40\text{ }^\circ\text{C to } 150\text{ }^\circ\text{C}$ , INA240A1EDRQ1, INA240A2EDRQ1, INA240A3EDRQ1, INA240A4EDRQ1		$\pm 1$	$\pm 10$	
$I_B$	Input bias current	$I_{B+}$ , $I_{B-}$ , $V_{\text{SENSE}} = 0\text{ mV}$		90		$\mu\text{A}$
	Reference input range		0		$V_S$	V
<b>OUTPUT</b>						
G	Gain	INA240A1-Q1		20		V/V
		INA240A2-Q1		50		
		INA240A3-Q1		100		
		INA240A4-Q1		200		
	Gain error	$\text{GND} + 50\text{ mV} \leq V_{\text{OUT}} \leq V_S - 200\text{ mV}$ $T_A = -40\text{ }^\circ\text{C to } 125\text{ }^\circ\text{C}$		$\pm 0.05\%$	$\pm 0.20\%$	ppm/ $^\circ\text{C}$
		$T_A = -40\text{ }^\circ\text{C to } 150\text{ }^\circ\text{C}$ , INA240A1EDRQ1, INA240A2EDRQ1, INA240A3EDRQ1, INA240A4EDRQ1		$\pm 0.5$	$\pm 2.5$	
		$\text{GND} + 10\text{ mV} \leq V_{\text{OUT}} \leq V_S - 200\text{ mV}$		$\pm 0.01\%$		
	Reference divider accuracy	$V_{\text{OUT}} =  (V_{\text{REF}1} - V_{\text{REF}2})  / 2$ at $V_{\text{SENSE}} = 0\text{ mV}$ , $T_A = -40\text{ }^\circ\text{C to } 125\text{ }^\circ\text{C}$		0.02%	0.1%	
		$T_A = -40\text{ }^\circ\text{C to } 150\text{ }^\circ\text{C}$ , INA240A1EDRQ1, INA240A2EDRQ1, INA240A3EDRQ1, INA240A4EDRQ1		0.02%	0.1%	
RVRR	Reference voltage rejection ratio (input-referred)	INA240A1-Q1		20		$\mu\text{V}/\text{V}$
		INA240A3-Q1		5		
		INA240A2-Q1, INA240A4-Q1		2		
	Maximum capacitive load	No sustained oscillation		1		nF
<b>VOLTAGE OUTPUT<sup>(2)</sup></b>						
	Swing to $V_S$ power-supply rail	$R_L = 10\text{ k}\Omega$ to GND $T_A = -40\text{ }^\circ\text{C to } 125\text{ }^\circ\text{C}$		$V_S - 0.05$	$V_S - 0.2$	V
		$T_A = -40\text{ }^\circ\text{C to } 150\text{ }^\circ\text{C}$ , INA240A1EDRQ1, INA240A2EDRQ1, INA240A3EDRQ1, INA240A4EDRQ1		$V_S - 0.05$	$V_S - 0.2$	
	Swing to GND	$R_L = 10\text{ k}\Omega$ to GND, $V_{\text{SENSE}} = 0\text{ mV}$ $V_{\text{REF}1} = V_{\text{REF}2} = 0\text{ V}$ $T_A = -40\text{ }^\circ\text{C to } 125\text{ }^\circ\text{C}$		$V_{\text{GND}} + 1$	$V_{\text{GND}} + 10$	mV
		$T_A = -40\text{ }^\circ\text{C to } 150\text{ }^\circ\text{C}$ , INA240A1EDRQ1, INA240A2EDRQ1, INA240A3EDRQ1, INA240A4EDRQ1		$V_{\text{GND}} + 1$	$V_{\text{GND}} + 10$	

**INA240-Q1**

ZHCSH56E – AUGUST 2016 – REVISED DECEMBER 2021

 at  $T_A = 25\text{ }^\circ\text{C}$ ,  $V_S = 5\text{ V}$ ,  $V_{\text{SENSE}} = V_{\text{IN}+} - V_{\text{IN}-}$ ,  $V_{\text{CM}} = 12\text{ V}$ , and  $V_{\text{REF1}} = V_{\text{REF2}} = V_S / 2$  (unless otherwise noted)

PARAMETER		TEST CONDITIONS	MIN	TYP	MAX	UNIT
<b>FREQUENCY RESPONSE</b>						
BW	Bandwidth	All gains, –3-dB bandwidth		400		kHz
		All gains, 2% THD+N <sup>(1)</sup>		100		
	Settling time - output settles to 0.5% of final value	INA240A1-Q1		9.6		μs
		INA240A4-Q1		9.8		
SR	Slew rate			2		V/μs
<b>NOISE (INPUT REFERRED)</b>						
	Voltage noise density			40		nV/√Hz
<b>POWER SUPPLY</b>						
V <sub>S</sub>	Operating voltage range	T <sub>A</sub> = –40°C to 125°C	2.7		5.5	V
		T <sub>A</sub> = –40°C to 150°C, INA240A1EDRQ1, INA240A2EDRQ1, INA240A3EDRQ1, INA240A4EDRQ1	2.7		5.5	
I <sub>Q</sub>	Quiescent current	V <sub>SENSE</sub> = 0 mV		1.8	2.4	mA
		I <sub>Q</sub> vs temperature, T <sub>A</sub> = –40°C to 125°C			2.6	
		T <sub>A</sub> = –40°C to 150°C, INA240A1EDRQ1, INA240A2EDRQ1, INA240A3EDRQ1, INA240A4EDRQ1			2.6	
<b>TEMPERATURE RANGE</b>						
	Specified range		–40		125	°C
		INA240A1EDRQ1, INA240A2EDRQ1, INA240A3EDRQ1, INA240A4EDRQ1	–40		150	

- (1) See the [Input Signal Bandwidth](#) section for more details.  
 (2) See [Figure 7-13](#).

## 7.6 Typical Characteristics

at  $T_A = 25^\circ\text{C}$ ,  $V_S = 5\text{ V}$ ,  $V_{CM} = 12\text{ V}$ , and  $V_{REF} = V_S / 2$  (unless otherwise noted)

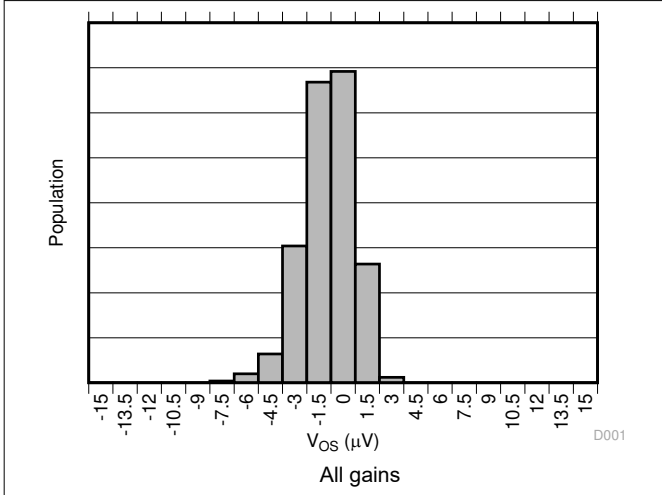

**图 7-1. Input Offset Voltage Production Distribution**

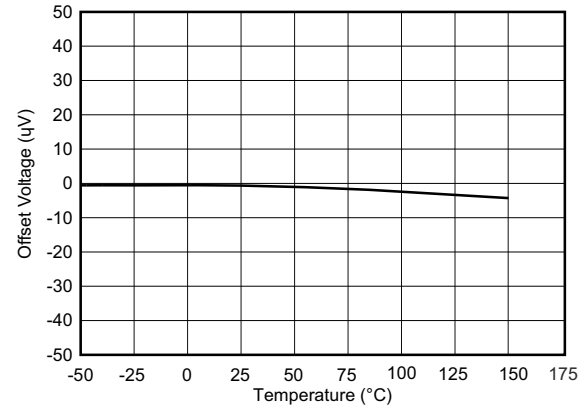

**图 7-2. Offset Voltage vs Temperature**

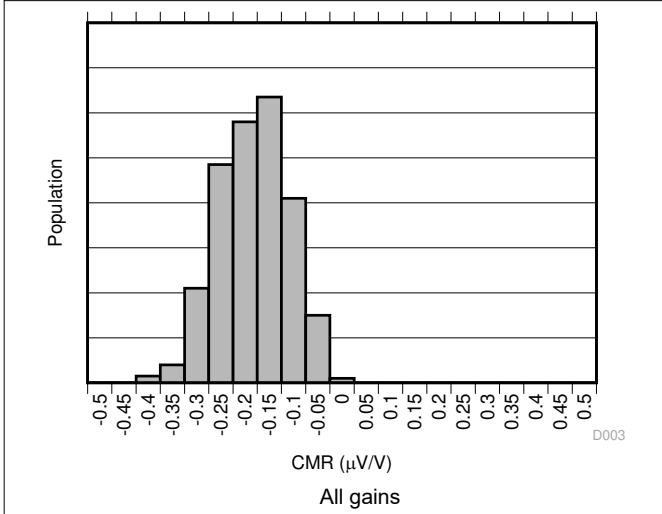

**图 7-3. Common-Mode Rejection Ratio Production Distribution**

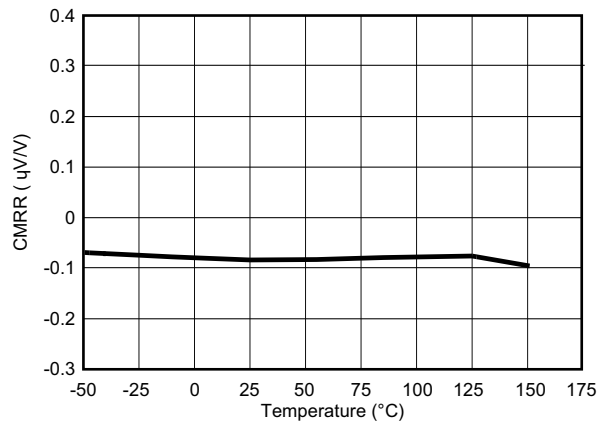

**图 7-4. Common-Mode Rejection Ratio vs Temperature**

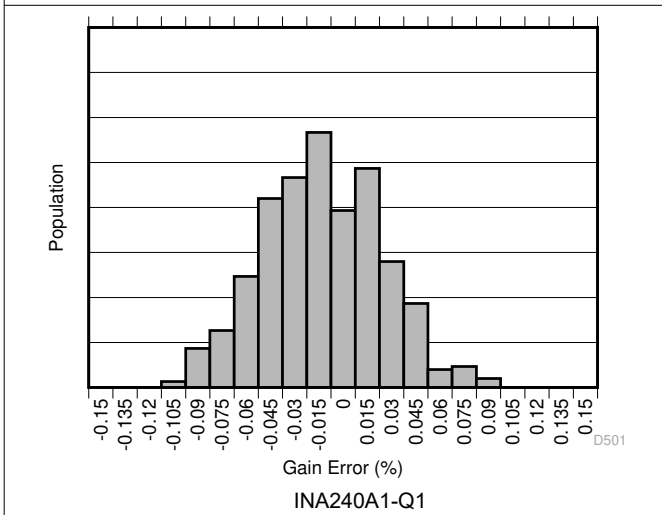

**图 7-5. Gain Error Production Distribution**

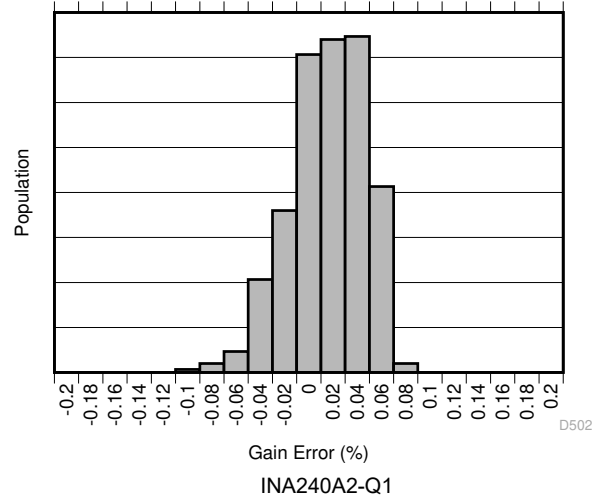

**图 7-6. Gain Error Production Distribution**

### 7.6 Typical Characteristics (continued)

at  $T_A = 25^\circ\text{C}$ ,  $V_S = 5\text{ V}$ ,  $V_{CM} = 12\text{ V}$ , and  $V_{REF} = V_S / 2$  (unless otherwise noted)



图 7-7. Gain Error Production Distribution



图 7-8. Gain Error Production Distribution

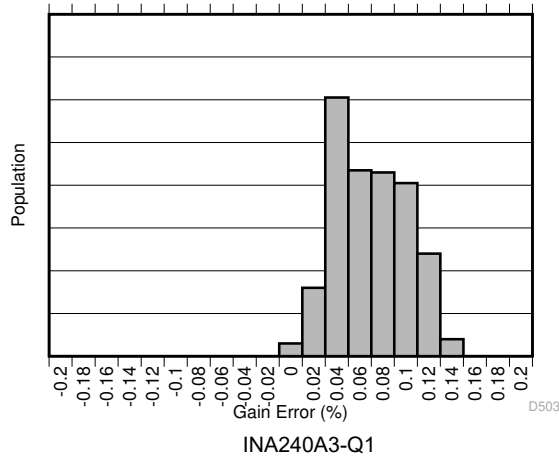

图 7-9. Gain Error vs Temperature

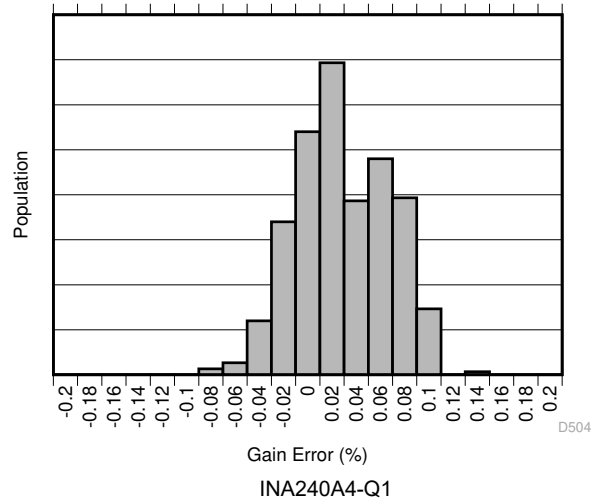

图 7-10. Gain vs Frequency

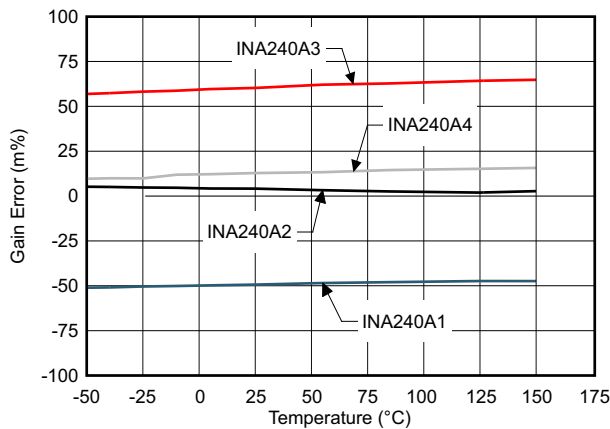

图 7-11. Power-Supply Rejection Ratio vs Frequency

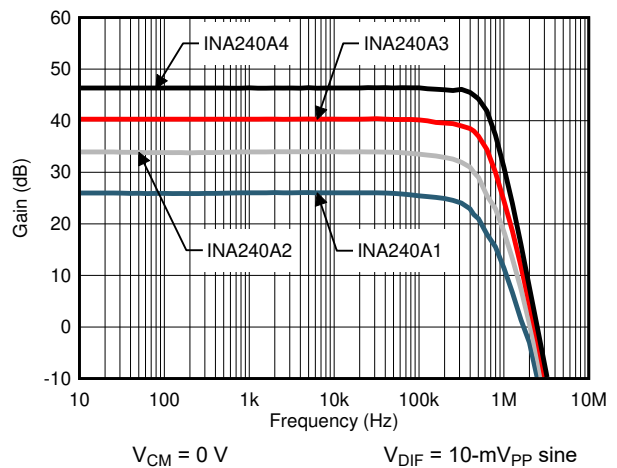

图 7-12. Common-Mode Rejection Ratio vs Frequency

## 7.6 Typical Characteristics (continued)

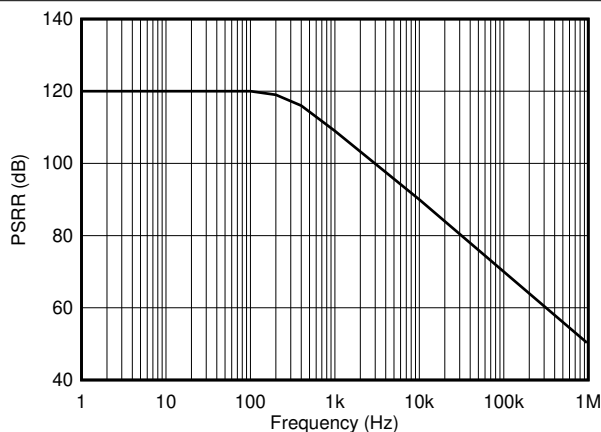
at  $T_A = 25^\circ\text{C}$ ,  $V_S = 5\text{ V}$ ,  $V_{CM} = 12\text{ V}$ , and  $V_{REF} = V_S / 2$  (unless otherwise noted)

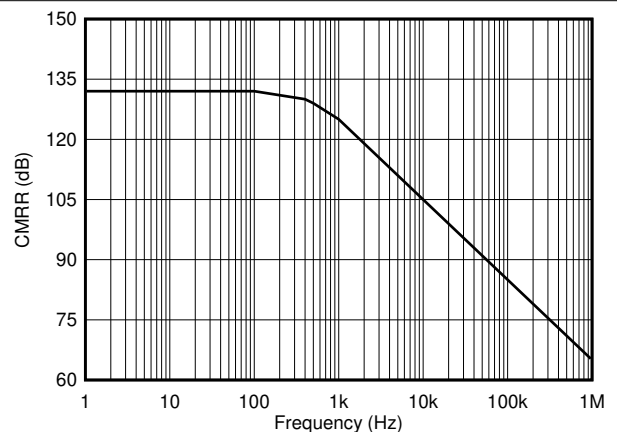

图 7-13. Output Voltage Swing vs Output Current



图 7-14. Input Bias Current vs Common-Mode Voltage

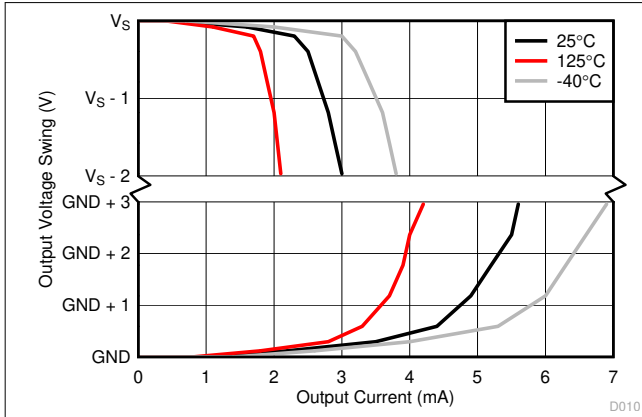

图 7-15. Input Bias Current vs Common-Mode Voltage

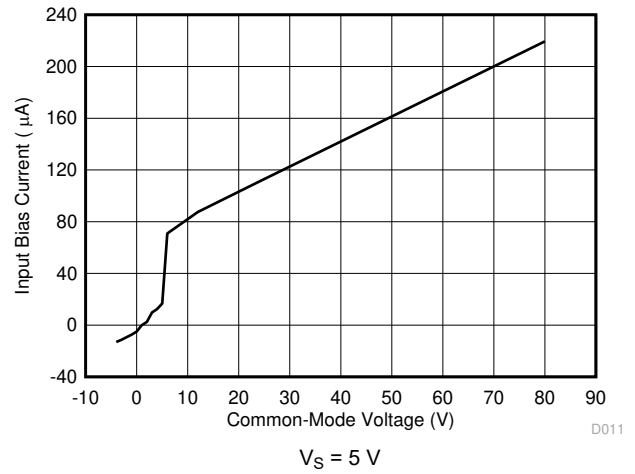

图 7-16. Input Bias Current vs Temperature

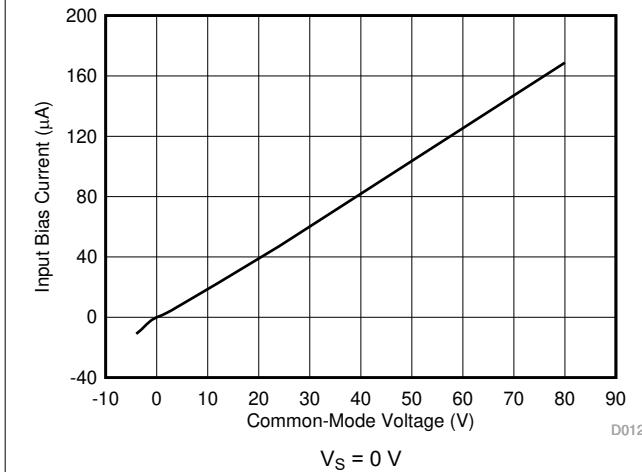

图 7-17. Quiescent Current vs Temperature

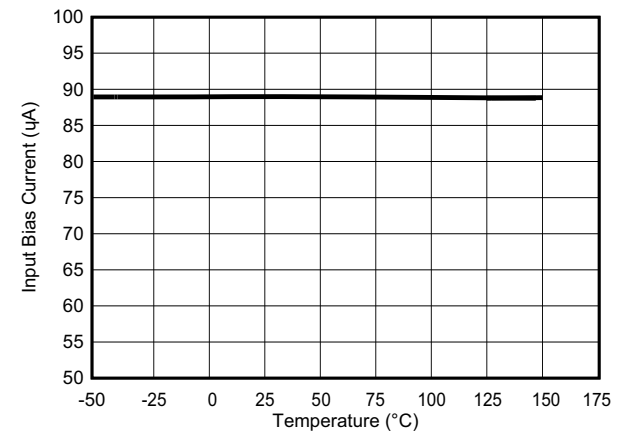

图 7-18. Input-Referred Voltage Noise vs Frequency

**INA240-Q1**

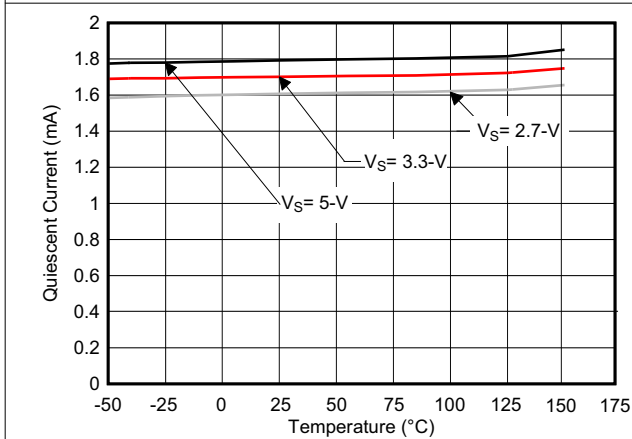
ZHCSH56E – AUGUST 2016 – REVISED DECEMBER 2021

**7.6 Typical Characteristics (continued)**

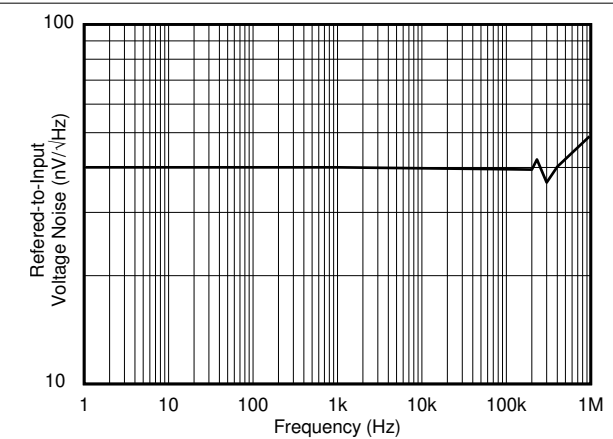
at  $T_A = 25^\circ\text{C}$ ,  $V_S = 5\text{ V}$ ,  $V_{CM} = 12\text{ V}$ , and  $V_{REF} = V_S / 2$  (unless otherwise noted)

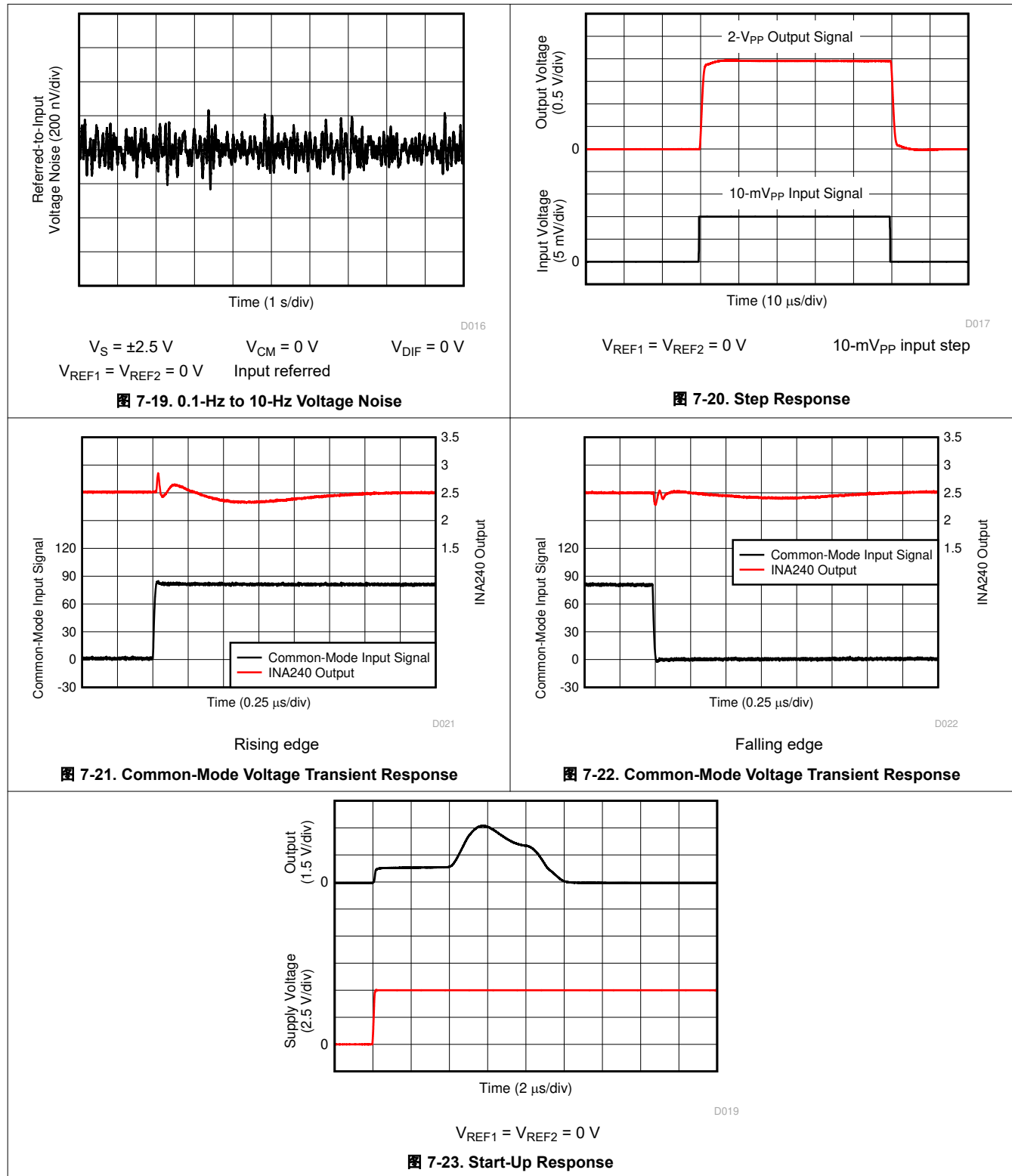

## 8 Detailed Description

### 8.1 Overview

The INA240-Q1 is a current-sense amplifier that offers a wide common-mode range, precision, zero-drift topology, excellent common-mode rejection ratio (CMRR), and features enhanced pulse width modulation (PWM) rejection. Enhanced PWM rejection reduces the effect of common-mode transients that are associated with PWM signals. Multiple gain versions are available to allow for the optimization of the desired full-scale output voltage based on the target current range expected in the application.

### 8.2 Functional Block Diagram

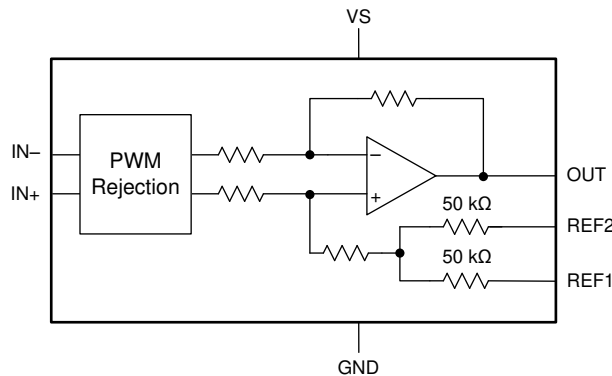

### 8.3 Feature Description

#### 8.3.1 Amplifier Input Signal

The INA240-Q1 is designed to handle large common-mode transients over a wide voltage range. Input signals from current measurement applications for linear and PWM applications can be connected to the amplifier to provide a highly accurate output, with minimal common-mode transient artifacts.

##### 8.3.1.1 Enhanced PWM Rejection Operation

The enhanced PWM rejection feature of the INA240-Q1 provides increased attenuation of large common-mode  $\Delta V/\Delta t$  transients. Large  $\Delta V/\Delta t$  common-mode transients associated with PWM signals are employed in applications such as motor or solenoid drive and switching power supplies. Traditionally, large  $\Delta V/\Delta t$  common-mode transitions are handled strictly by increasing the amplifier signal bandwidth, which can increase chip size, complexity and ultimately cost. The INA240-Q1 is designed with high common-mode rejection techniques to reduce large  $\Delta V/\Delta t$  transients before the system is disturbed as a result of these large signals. The high AC CMRR, in conjunction with signal bandwidth, allows the INA240-Q1 to provide minimal output transients and ringing compared with standard circuit approaches.

##### 8.3.1.2 Input Signal Bandwidth

The INA240-Q1 input signal, which represents the current being measured, is accurately measured with minimal disturbance from large  $\Delta V/\Delta t$  common-mode transients as previously described. For PWM signals typically associated with motors, solenoids, and other switching applications, the current being monitored varies at a significantly slower rate than the faster PWM frequency.

The INA240-Q1 bandwidth is defined by the  $-3$ -dB bandwidth of the current-sense amplifier inside the device; see the [Electrical Characteristics](#) table. The device bandwidth provides fast throughput and fast response required for the rapid detection and processing of overcurrent events. Without the higher bandwidth, protection circuitry may not have adequate response time and damage may occur to the monitored application or circuit.

图 8-1 shows the performance profile of the device over frequency. Harmonic distortion increases at the upper end of the amplifier bandwidth with no adverse change in detection of overcurrent events. However, increased distortion at the highest frequencies must be considered when the measured current bandwidth begins to approach the INA240-Q1 bandwidth.

For applications requiring distortion sensitive signals, 图 8-1 provides information to show that there is an optimal frequency performance range for the amplifier. The full amplifier bandwidth is always available for fast overcurrent events at the same time that the lower frequency signals are amplified at a low distortion level. The output signal accuracy is reduced for frequencies closer to the maximum bandwidth. Individual requirements determine the acceptable limits of distortion for high-frequency, current-sensing applications. Testing and evaluation in the end application or circuit is required to determine the acceptance criteria and to validate the performance levels meet the system specifications.



图 8-1. Performance Over Frequency

### 8.3.2 Selecting the Sense Resistor ( $R_{SENSE}$ )

The INA240-Q1 determines the current magnitude from measuring the differential voltage developed across a resistor. This resistor is referred to as a *current-sensing* resistor or a *current-shunt* resistor. The flexible design of the device allows a wide input signal range across this current-sensing resistor.

The current-sensing resistor is ideally chosen solely based on the full-scale current to be measured, the full-scale input range of the circuitry following the device, and the device gain selected. The minimum current-sensing resistor is a design-based decision in order to maximize the input range of the signal chain circuitry. Full-scale output signals that are not maximized to the full input range of the system circuitry limit the ability of the system to exercise the full dynamic range of system control.

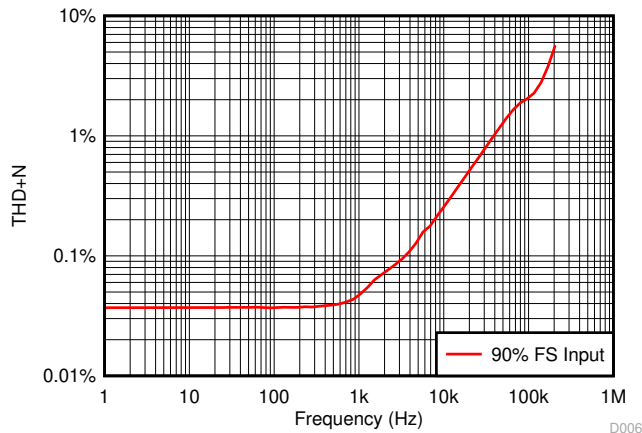
Two important factors to consider when finalizing the current-sensing resistor value are: the required current measurement accuracy and the maximum power dissipation across the resistor. A larger resistor voltage provides for a more accurate measurement, but increases the power dissipation in the resistor. The increased power dissipation generates heat, which reduces the sense resistor accuracy because of the temperature coefficient. The voltage signal measurement uncertainty is reduced when the input signal gets larger because any fixed errors become a smaller percentage of the measured signal. The design trade-off to improve measurement accuracy increases the current-sensing resistor value. The increased resistance value results in an increased power dissipation in the system which can additionally decrease the overall system accuracy. Based on these relationships, the measurement accuracy is inversely proportional to both the resistance value and power dissipation contributed by the current-shunt selection.

By increasing the current-shunt resistor, the differential voltage is increased across the resistor. Larger input differential voltages require a smaller amplifier gain to achieve a full-scale amplifier output voltage. Smaller current-shunt resistors are desired but require large amplifier gain settings. The larger gain settings often have increased error and noise parameters, which are not attractive for precision designs. Historically, the design goals for high-performance measurements forced designers to accept selecting larger current-sense resistors and the lower gain amplifier settings. The INA240-Q1 provides 100-V/V and 200-V/V gain options that offer the

high-gain setting and maintains high-performance levels with offset values below 25  $\mu\text{V}$ . These devices allow for the use of lower shunt resistor values to achieve lower power dissipation and still meet high system performance specifications.

表 8-1 shows an example of the different results obtained from using two different gain versions of the INA240-Q1. From the table data, the higher gain device allows a smaller current-shunt resistor and decreased power dissipation in the element. The [Calculating Total Error](#) section provides information on the error calculations that must be considered in addition to the gain and current-shunt value when designing with the INA240-Q1.

表 8-1.  $R_{\text{SENSE}}$  Selection and Power Dissipation<sup>(1)</sup>

PARAMETER	EQUATION	RESULTS		
		INA240A1-Q1	INA240A4-Q1	
Gain	—	20 V/V	200 V/V	
$V_{\text{DIFF}}$	Ideal maximum differential input voltage	$V_{\text{DIFF}} = V_{\text{OUT}} / \text{Gain}$	150 mV	15 mV
$R_{\text{SENSE}}$	Current-sense resistor value	$R_{\text{SENSE}} = V_{\text{DIFF}} / I_{\text{MAX}}$	15 m $\Omega$	1.5 m $\Omega$
$P_{\text{RSENSE}}$	Current-sense resistor power dissipation	$R_{\text{SENSE}} \times I_{\text{MAX}}^2$	1.5 W	0.15 W

(1) Full-scale current = 10 A, and full-scale output voltage = 3 V.

## 8.4 Device Functional Modes

### 8.4.1 Adjusting the Output Midpoint With the Reference Pins

图 8-2 shows a test circuit for reference-divider accuracy. The INA240-Q1 output is configurable to allow for unidirectional or bidirectional operation.



图 8-2. Test Circuit For Reference Divider Accuracy

#### 备注

Do not connect the REF1 pin or the REF2 pin to any voltage source lower than GND or higher than  $V_S$ .

The output voltage is set by applying a voltage or voltages to the reference voltage inputs, REF1 and REF2. The reference inputs are connected to an internal gain network. There is no operational difference between the two reference pins.

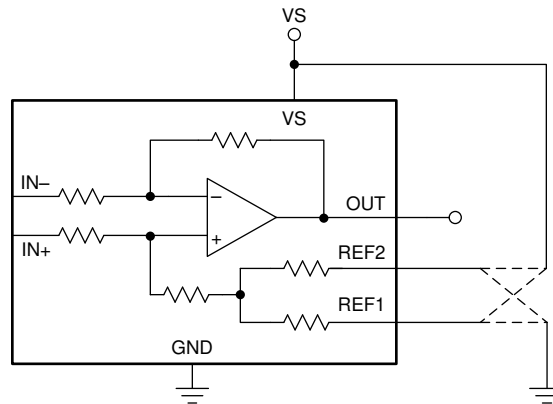
### 8.4.2 Reference Pin Connections for Unidirectional Current Measurements

Unidirectional operation allows current measurements through a resistive shunt in one direction. For unidirectional operation, connect the device reference pins together and then to the negative rail (see the [Ground Referenced Output](#) section) or the positive rail (see the [VS Referenced Output](#) section). The required differential input polarity depends on the output voltage setting. The amplifier output moves away from the referenced rail proportional to the current passing through the external shunt resistor. If the amplifier reference pins are connected to the positive rail, then the input polarity must be negative to move the amplifier output down

(towards ground). If the amplifier reference pins are connected at ground, then the input polarity must be positive to move the amplifier output up (towards supply).

The following sections describe how to configure the output for unidirectional operation cases.

#### 8.4.2.1 Ground Referenced Output

When using the INA240-Q1 in a unidirectional mode with a ground referenced output, both reference inputs are connected to ground; this configuration takes the output to ground when there is a 0-V differential at the input (as [Figure 8-3](#) shows).

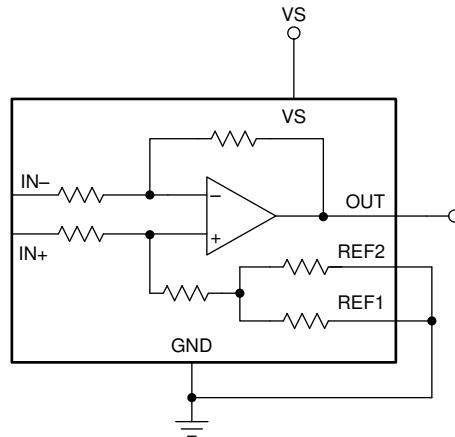

**Figure 8-3. Ground Referenced Output**

#### 8.4.2.2 VS Referenced Output

Unidirectional mode with a VS referenced output is configured by connecting both reference pins to the positive supply. Use this configuration for circuits that require power-up and stabilization of the amplifier output signal and other control circuitry before power is applied to the load (as shown in [Figure 8-4](#)).

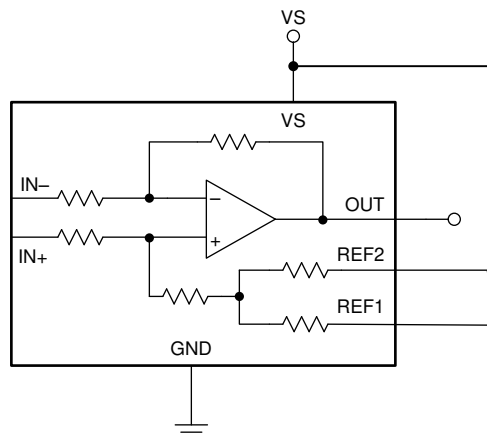

**Figure 8-4. VS Referenced Output**

#### 8.4.3 Reference Pin Connections for Bidirectional Current Measurements

Bidirectional operation allows the INA240-Q1 to measure currents through a resistive shunt in two directions. For this operation case, the output voltage can be set anywhere within the reference input limits. A common configuration is to set the reference inputs at half-scale for equal range in both directions. However, the reference inputs can be set to a voltage other than half-scale when the bidirectional current is non-symmetrical.

### 8.4.3.1 Output Set to External Reference Voltage

Connecting both pins together and then to a reference voltage results in an output voltage equal to the reference voltage for the condition of shorted input pins or a 0-V differential input; this configuration is shown in [图 8-5](#). The output voltage decreases below the reference voltage when the IN+ pin is negative relative to the IN- pin and increases when the IN+ pin is positive relative to the IN- pin. This technique is the most accurate way to bias the output to a precise voltage.

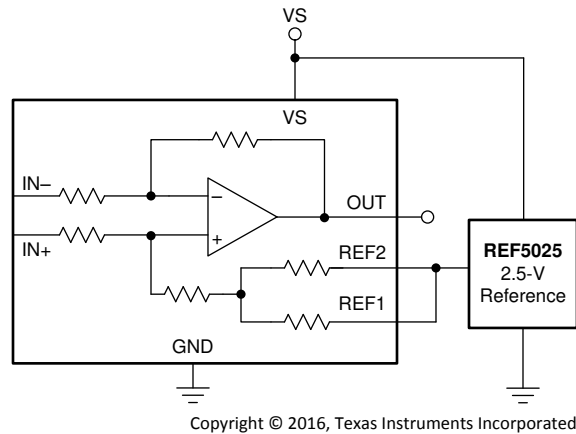

**图 8-5. External Reference Output**

### 8.4.3.2 Output Set to Midsupply Voltage

By connecting one reference pin to VS and the other to the GND pin, the output is set at half of the supply when there is no differential input, as shown in [图 8-6](#). This method creates a ratiometric offset to the supply voltage, where the output voltage remains at  $VS / 2$  for 0 V applied to the inputs.

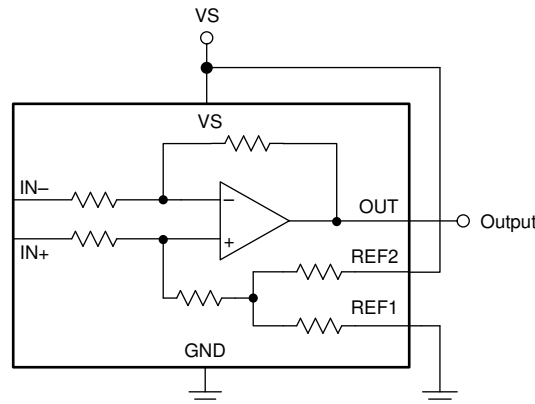

**图 8-6. Midsupply Voltage Output**

### 8.4.3.3 Output Set to Mid-External Reference

In this case, an external reference is divided by two by connecting one REF pin to ground and the other REF pin to the reference, as shown in [图 8-7](#).

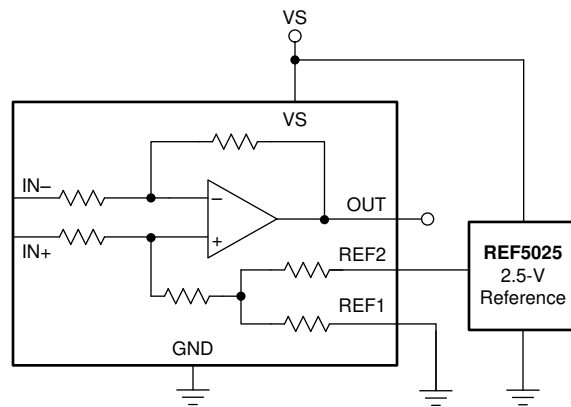

Copyright © 2016, Texas Instruments Incorporated

图 8-7. Mid-External Reference Output

#### 8.4.3.4 Output Set Using Resistor Divider

The INA240-Q1 REF1 and REF2 pins allow for the midpoint of the output voltage to be adjusted for system circuitry connections to analog to digital converters (ADCs) or other amplifiers. The REF pins are designed to be connected directly to supply, ground, or a low-impedance reference voltage. The REF pins can be connected together and biased using a resistor divider to achieve a custom output voltage. If the amplifier is used in this configuration, as shown in 图 8-8, use the output as a differential signal with respect to the resistor divider voltage. Use of the amplifier output as a single-ended signal in this configuration is not recommended because the internal impedance shifts can adversely affect device performance specifications.



图 8-8. Setting the Reference Using a Resistor Divider

#### 8.4.4 Calculating Total Error

The INA240-Q1 electrical specifications (see the [Electrical Characteristics](#) table) include typical individual error terms (such as gain error, offset error, and nonlinearity error). Total error, including all of these individual error components, is not specified in the [Electrical Characteristics](#) table. In order to accurately calculate the expected error of the device, the device operating conditions must first be known. Some current-shunt monitors specify a total error in the product data sheet. However, this total error term is accurate under only one particular set of operating conditions. Specifying the total error at this point has limited value because any deviation from these specific operating conditions no longer yields the same total error value. This section discusses the individual error sources and how the device total error value can be calculated from the combination of these errors for specific conditions.

Two examples are provided in 表 8-2 and 表 8-3 that detail how different operating conditions can affect the total error calculations. Typical and maximum calculations are shown as well to provide the user more information on how much error variance is present from device to device.

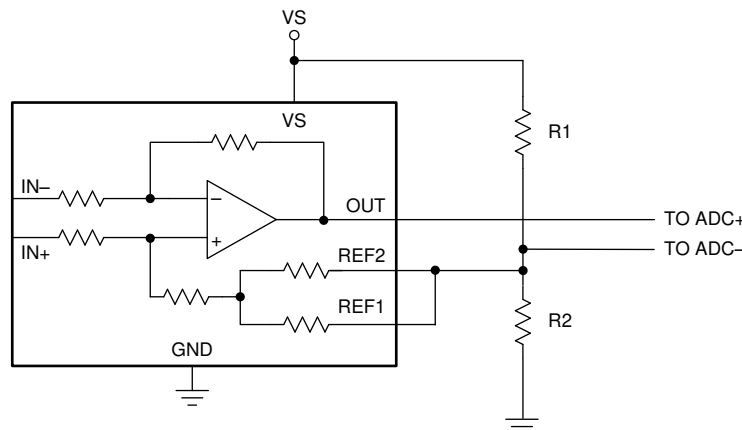
### 8.4.4.1 Error Sources

The typical error sources that have the largest effect on the total error of the device are gain error, nonlinearity, common-mode rejection ratio, and input offset voltage error. For the INA240-Q1, an additional error source (referred to as the *reference voltage rejection ratio*) is also included in the total error value.

### 8.4.4.2 Reference Voltage Rejection Ratio Error

Reference voltage rejection ratio refers to the amount of error induced by applying a reference voltage to the INA240-Q1 that deviates from the mid-point of the device supply voltage.

#### 8.4.4.2.1 Total Error Example 1

**表 8-2. Total Error Calculation: Example 1<sup>(1)</sup>**

TERM	SYMBOL	EQUATION	TYPICAL VALUE
Initial input offset voltage	$V_{OS}$	—	5 $\mu$ V
Added input offset voltage because of common-mode voltage	$V_{OS\_CM}$	$\frac{1}{10^{\left(\frac{CMRR_{dB}}{20}\right)}} \times (V_{CM} - 12V)$	0 $\mu$ V
Added input offset voltage because of reference voltage	$V_{OS\_REF}$	$RVRR \times  V_S / 2 - V_{REF} $	0 $\mu$ V
Total input offset voltage	$V_{OS\_Total}$	$\sqrt{(V_{OS})^2 + (V_{OS\_CM})^2 + (V_{OS\_REF})^2}$	5 $\mu$ V
Error from input offset voltage	Error_Vos	$\frac{V_{OS\_Total}}{V_{SENSE}} \times 100$	0.05%
Gain error	Error_Gain	—	0.05%
Nonlinearity error	Error_Lin	—	0.01%
<b>Total error</b>	—	$\sqrt{(\text{Error\_Vos})^2 + (\text{Error\_Gain})^2 + (\text{Error\_Lin})^2}$	0.07%

(1) The data for 表 8-2 was taken with the INA240A4-Q1,  $V_S = 5$  V,  $V_{CM} = 12$  V,  $V_{REF1} = V_{REF2} = V_S / 2$ , and  $V_{SENSE} = 10$  mV.

#### 8.4.4.2.2 Total Error Example 2

**表 8-3. Total Error Calculation: Example 2<sup>(1)</sup>**

TERM	SYMBOL	EQUATION	TYPICAL VALUE
Initial input offset voltage	$V_{OS}$	—	5 $\mu$ V
Added input offset voltage because of common-mode voltage	$V_{OS\_CM}$	$\frac{1}{10^{\left(\frac{CMRR_{dB}}{20}\right)}} \times (V_{CM} - 12V)$	12.1 $\mu$ V
Added input offset voltage because of reference voltage	$V_{OS\_REF}$	$RVRR \times  V_S / 2 - V_{REF} $	5 $\mu$ V
Total input offset voltage	$V_{OS\_Total}$	$\sqrt{(V_{OS})^2 + (V_{OS\_CM})^2 + (V_{OS\_REF})^2}$	14 $\mu$ V
Error from input offset voltage	Error_Vos	$\frac{V_{OS\_Total}}{V_{SENSE}} \times 100$	0.14%
Gain error	Error_Gain	—	0.05%
Nonlinearity error	Error_Lin	—	0.01%

**表 8-3. Total Error Calculation: Example 2<sup>(1)</sup> (continued)**

TERM	SYMBOL	EQUATION	TYPICAL VALUE
Total error	—	$\sqrt{(\text{Error\_V}_{\text{OS}})^2 + (\text{Error\_Gain})^2 + (\text{Error\_Lin})^2}$	0.15%

(1) The data for 表 8-3 was taken with the INA240A4-Q1,  $V_S = 5\text{ V}$ ,  $V_{\text{CM}} = 60\text{ V}$ ,  $V_{\text{REF1}} = V_{\text{REF2}} = 0\text{ V}$ , and  $V_{\text{SENSE}} = 10\text{ mV}$ .

## 9 Application and Implementation

### 备注

以下应用部分中的信息不属于 TI 器件规格的范围，TI 不担保其准确性和完整性。TI 的客户应负责确定器件是否适用于其应用。客户应验证并测试其设计，以确保系统功能。

### 9.1 Application Information

The INA240-Q1 measures the voltage developed as current flows across the current-sensing resistor. The device provides reference pins to configure operation as either unidirectional or bidirectional output swing. When using the INA240-Q1 for inline motor current sense, the device is commonly configured for bidirectional operation.

#### 9.1.1 Input Filtering

### 备注

Input filters are not required for accurate measurements using the INA240-Q1, and use of filters in this location is not recommended. If filter components are used on the input of the amplifier, follow the guidelines in this section to minimize the effects on performance.

Based strictly on user design requirements, external filtering of the current signal may be desired. The initial location that can be considered for the filter is at the output of the current amplifier. Although placing the filter at the output satisfies the filtering requirements, this location changes the low output impedance measured by any circuitry connected to the output voltage pin. The other location for filter placement is at the current amplifier input pins. This location satisfies the filtering requirement also, however the components must be carefully selected to minimally impact device performance. 图 9-1 shows a filter placed at the inputs pins.



图 9-1. Filter at Input Pins

External series resistance provide a source of additional measurement error, so keep the value of these series resistors to 10- $\Omega$  or less to reduce loss of accuracy. The internal bias network shown in 图 9-1 creates a mismatch in input bias currents (see 图 9-2) when a differential voltage is applied between the input pins. If additional external series filter resistors are added to the circuit, a mismatch is created in the voltage drop across the filter resistors. This voltage is a differential error voltage in the shunt resistor voltage. In addition to the absolute resistor value, mismatch resulting from resistor tolerance can significantly impact the error because this value is calculated based on the actual measured resistance.

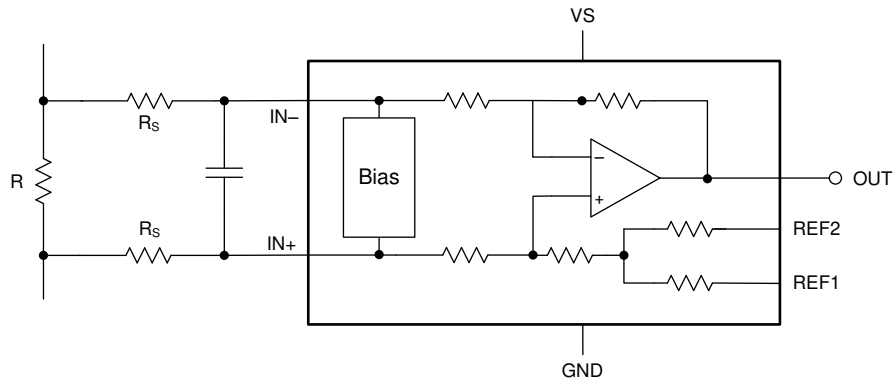
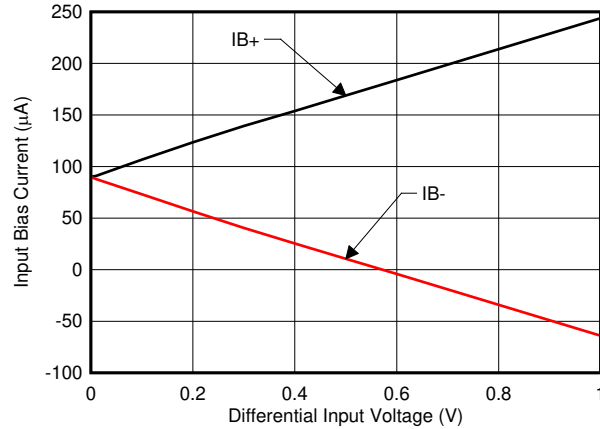

**图 9-2. Input Bias Current vs Differential Input Voltage**

The measurement error expected from the additional external filter resistors can be calculated using [方程式 1](#), where the gain error factor is calculated using [方程式 2](#).

$$\text{Gain Error (\%)} = 100 - (100 \times \text{Gain Error Factor}) \tag{1}$$

The gain error factor, shown in [方程式 1](#), can be calculated to determine the gain error introduced by the additional external series resistance. [方程式 1](#) calculates the deviation of the shunt voltage resulting from the attenuation and imbalance created by the added external filter resistance. [表 9-1](#) provides the gain error factor and gain error for several resistor values.

$$\text{Gain Error Factor} = \frac{3000}{R_S + 3000} \tag{2}$$

Where:

- $R_S$  is the external filter resistance value

**表 9-1. Gain Error Factor and Gain Error For External Input Resistors**

EXTERNAL RESISTANCE (Ω)	GAIN ERROR FACTOR	GAIN ERROR (%)
5	0.998	0.17
10	0.997	0.33
100	0.968	3.23

## 9.2 Typical Applications

The INA240-Q1 offers advantages for multiple applications including the following:

- High common-mode range and excellent CMRR enables direct inline sensing
- Ultra-low offset and drift eliminates the necessity of calibration
- Wide supply range enables a direct interface with most microprocessors

Two specific applications are provided and include more detailed information.

### 9.2.1 Inline Motor Current-Sense Application

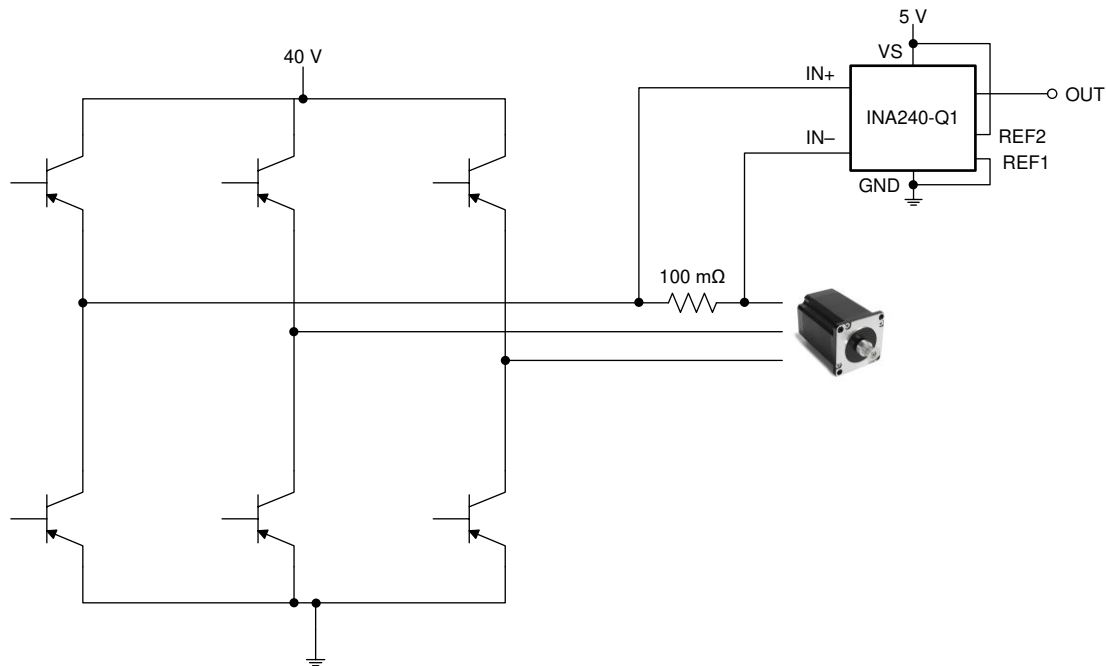

Copyright © 2017, Texas Instruments Incorporated

**图 9-3. Inline Motor Application Circuit**

#### 9.2.1.1 Design Requirements

Inline current sensing has many advantages in motor control, from torque ripple reduction to real-time motor health monitoring. However, the full-scale PWM voltage requirements for inline current measurements provide challenges to accurately measure the current. Switching frequencies in the 50-kHz to 100-kHz range create higher  $\Delta V/\Delta t$  signal transitions that must be addressed to obtain accurate inline current measurements.

With a superior common-mode rejection capability, high precision, and a high common-mode specification, the INA240-Q1 provides performance for a wide range of common-mode voltages.

#### 9.2.1.2 Detailed Design Procedure

For this application, the INA240-Q1 measures current in the drive circuitry of a 36-V, 4000-RPM motor.

To demonstrate the performance of the device, the INA240A1-Q1 with a gain of 20 V/V was selected for this design and powered from a 5-V supply.

Using the information in the [Adjusting the Output Midpoint With the Reference Pins](#) section, the reference point is set to midscale by splitting the supply with REF1 connected to ground and REF2 connected to supply. This configuration allows for bipolar current measurements. Alternatively, the reference pins can be tied together and driven with an external precision reference.

The current-sensing resistor is sized so that the output of the INA240-Q1 is not saturated. A value of 100-mΩ was selected to maintain the analog input within the device limits.

### 9.2.1.3 Application Curve

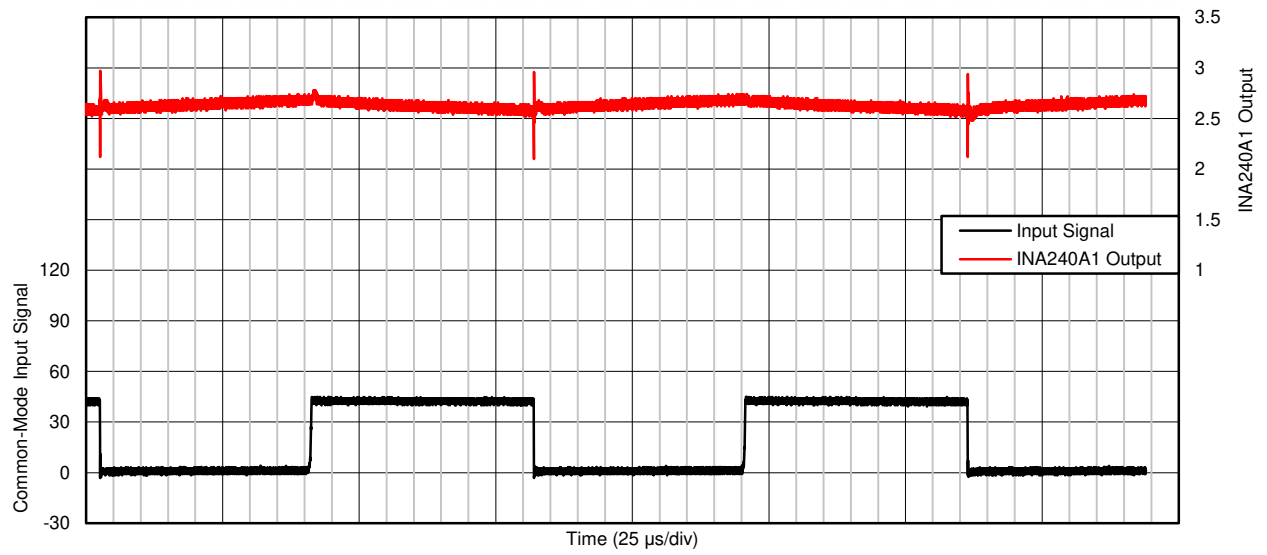

C005

**图 9-4. Inline Motor Current-Sense Input and Output Signals**

## 9.2.2 Solenoid Drive Current-Sense Application

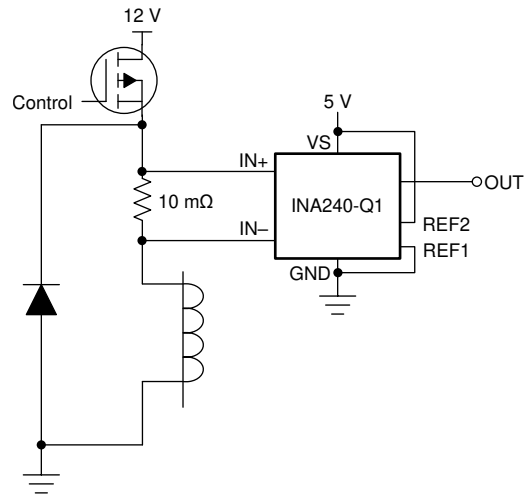

Copyright © 2016, Texas Instruments Incorporated

图 9-5. Solenoid Drive Application Circuit

### 9.2.2.1 Design Requirements

Challenges exist in solenoid drive current sensing that are similar to those in motor in-line current sensing. In certain topologies, the current-sensing amplifier is exposed to the full-scale PWM voltage between ground and supply. The INA240-Q1 is well suited for this type of application.

### 9.2.2.2 Detailed Design Procedure

For this application, the INA240-Q1 measures current in the driver circuit of a 24-V, 500-mA water valve.

To demonstrate the performance of the device, the INA240A4-Q1 with a gain of 200 V/V was selected for this design and powered from a 5-V supply.

Using the information in the [Adjusting the Output Midpoint With the Reference Pins](#) section, the reference point is set to midscale by splitting the supply with REF1 connected to ground and REF2 connected to supply. Alternatively, the reference pins can be tied together and driven with an external precision reference.

A value of 10 mΩ was selected to maintain the analog input within the device limits.

### 9.2.2.3 Application Curve



图 9-6. Solenoid Drive Current Sense Input and Output Signals

## 9.3 What to Do and What Not to Do

### 9.3.1 High-Precision Applications

For high-precision applications, verify accuracy and stability of the amplifier by:

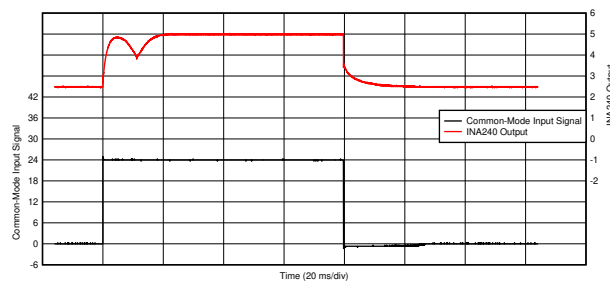
- Providing a precision reference connected to REF1 and REF2
- Optimizing the layout of the power and sensing path of the sense resistor (see the [Layout](#) section)
- Providing adequate bypass capacitance on the supply pin (see the [Power Supply Decoupling](#) section)

### 9.3.2 Kelvin Connection from the Current-Sense Resistor

To provide accurate current measurements, verify the routing between the current-sense resistor and the amplifier uses a Kelvin connection. Use the information provided in [Figure 9-7](#) and the [Connection to the Current-Sense Resistor](#) section during device layout.

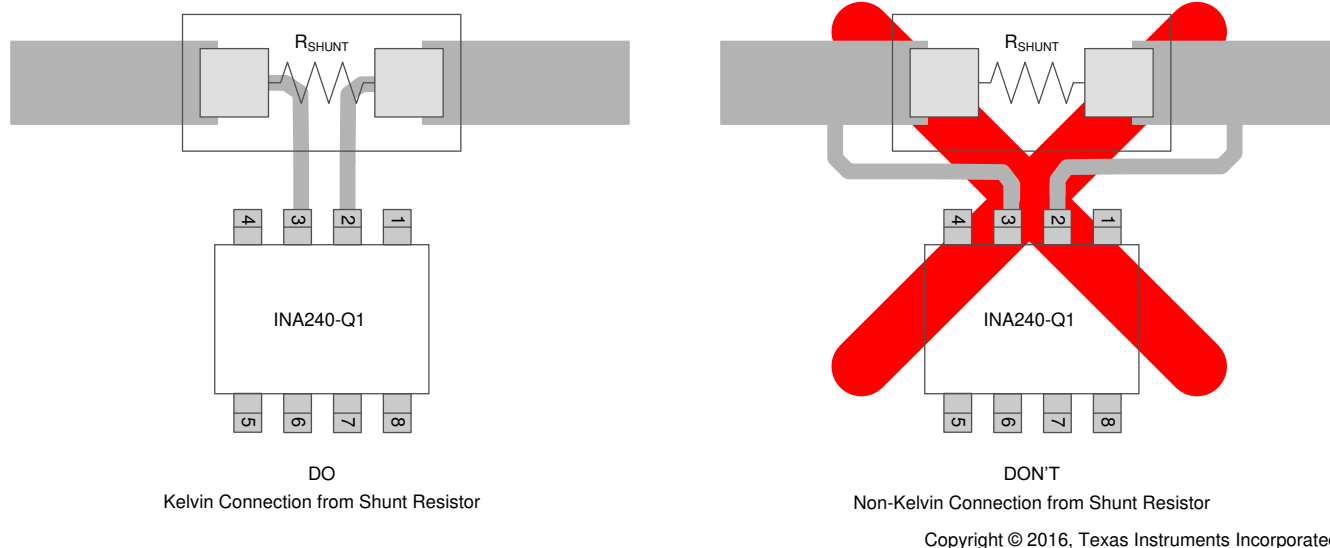

**图 9-7. Shunt Connections to the INA240-Q1**

## 10 Power Supply Recommendations

The INA240-Q1 series makes accurate measurements beyond the connected power-supply voltage ( $V_S$ ) because the inputs (IN+ and IN-) operate anywhere between  $-4$  V and 80 V independent of  $V_S$ . For example, the  $V_S$  power supply equals 5 V and the common-mode voltage of the measured shunt can be as high as 80 V.

Although the common-mode voltage of the input can be beyond the supply voltage, the output voltage range of the INA240-Q1 series is constrained to the supply voltage.

### 10.1 Power Supply Decoupling

Place the power-supply bypass capacitor as close as possible to the supply and ground pins. TI recommends a bypass capacitor value of 0.1  $\mu$ F. Additional decoupling capacitance can be added to compensate for noisy or high-impedance power supplies.

## 11 Layout

### 11.1 Layout Guidelines

#### 11.1.1 Connection to the Current-Sense Resistor

Poor routing of the current-sensing resistor can result in additional resistance between the input pins of the amplifier. Any additional high-current carrying impedance can cause significant measurement errors because the current resistor has a very-low-ohmic value. Use a Kelvin or 4-wire connection to connect to the device input pins. This connection technique ensures that only the current-sensing resistor impedance is detected between the input pins.

#### 11.2 Layout Example

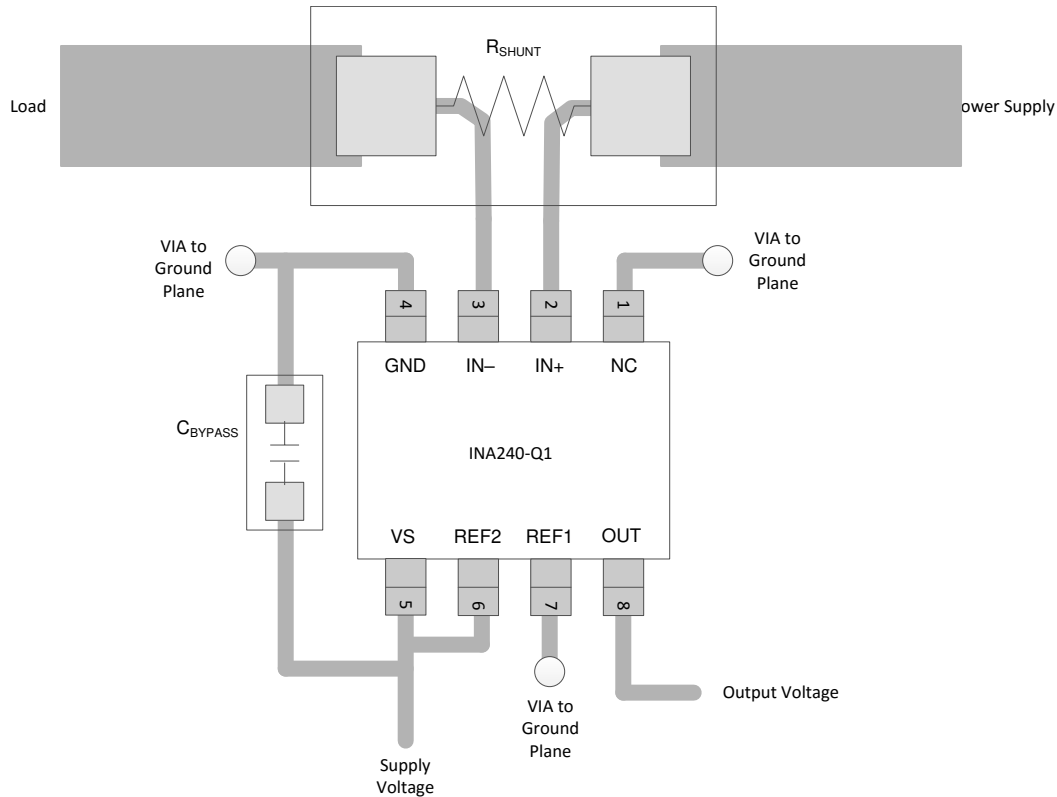

Copyright © 2016, Texas Instruments Incorporated

**图 11-1. Recommended TSSOP Package Layout**

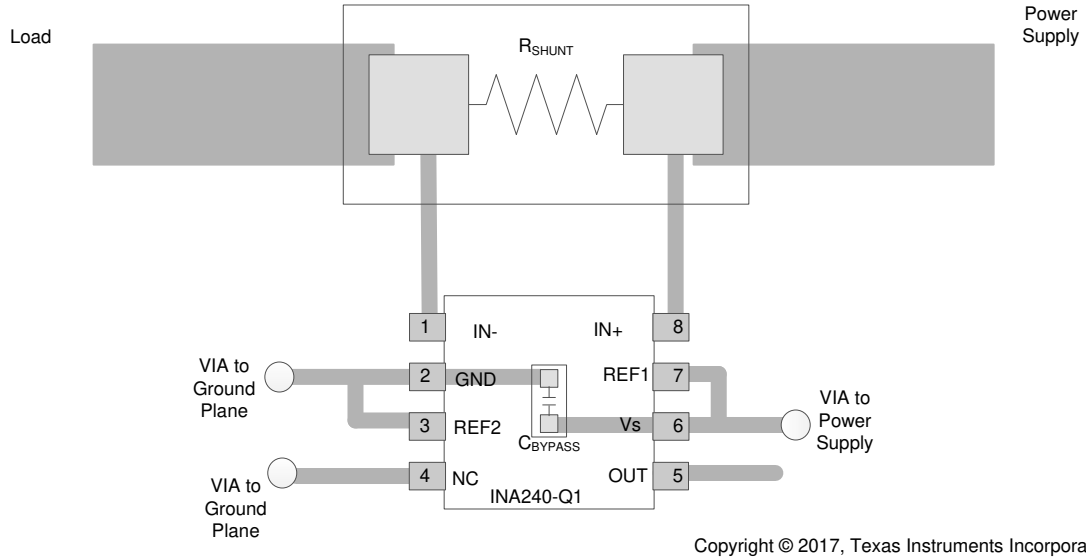

**图 11-2. Recommended SOIC Package Layout**

## 12 Device and Documentation Support

### 12.1 Documentation Support

#### 12.1.1 Related Documentation

For related documentation see the following:

- Texas Instruments, [INA240EVM User's Guide](#)
- Texas Instruments, [Motor Control Application Report](#)
- Texas Instruments, [48-V Three-Phase Inverter With Shunt-Based In-Line Motor Phase Current Sensing Reference Design](#)

### 12.2 接收文档更新通知

要接收文档更新通知，请导航至 [ti.com](http://ti.com) 上的器件产品文件夹。点击 [订阅更新](#) 进行注册，即可每周接收产品信息更改摘要。有关更改的详细信息，请查看任何已修订文档中包含的修订历史记录。

### 12.3 支持资源

TI E2E™ [支持论坛](#) 是工程师的重要参考资料，可直接从专家获得快速、经过验证的解答和设计帮助。搜索现有解答或提出自己的问题可获得所需的快速设计帮助。

链接的内容由各个贡献者“按原样”提供。这些内容并不构成 TI 技术规范，并且不一定反映 TI 的观点；请参阅 TI 的 [《使用条款》](#)。

### 12.4 Trademarks

TI E2E™ is a trademark of Texas Instruments.  
所有商标均为其各自所有者的财产。

### 12.5 Electrostatic Discharge Caution



This integrated circuit can be damaged by ESD. Texas Instruments recommends that all integrated circuits be handled with appropriate precautions. Failure to observe proper handling and installation procedures can cause damage.

ESD damage can range from subtle performance degradation to complete device failure. Precision integrated circuits may be more susceptible to damage because very small parametric changes could cause the device not to meet its published specifications.

### 12.6 术语表

[TI 术语表](#) 本术语表列出并解释了术语、首字母缩略词和定义。

## 13 Mechanical, Packaging, and Orderable Information

The following pages include mechanical, packaging, and orderable information. This information is the most current data available for the designated devices. This data is subject to change without notice and revision of this document. For browser-based versions of this data sheet, refer to the left-hand navigation.

## PACKAGING INFORMATION

Orderable Device	Status (1)	Package Type	Package Drawing	Pins	Package Qty	Eco Plan (2)	Lead finish/ Ball material (6)	MSL Peak Temp (3)	Op Temp (°C)	Device Marking (4/5)	Samples
INA240A1EDRQ1	ACTIVE	SOIC	D	8	2500	RoHS & Green	NIPDAU	Level-2-260C-1 YEAR	-40 to 150	240A1E	<a href="#">Samples</a>
INA240A1QDRQ1	ACTIVE	SOIC	D	8	2500	RoHS & Green	NIPDAU	Level-2-260C-1 YEAR	-40 to 125	240A1Q	<a href="#">Samples</a>
INA240A1QPWRQ1	ACTIVE	TSSOP	PW	8	2000	RoHS & Green	NIPDAU	Level-3-260C-168 HR	-40 to 125	Q240A1	<a href="#">Samples</a>
INA240A2EDRQ1	ACTIVE	SOIC	D	8	2500	RoHS & Green	NIPDAU	Level-2-260C-1 YEAR	-40 to 150	240A2E	<a href="#">Samples</a>
INA240A2QDRQ1	ACTIVE	SOIC	D	8	2500	RoHS & Green	NIPDAU	Level-2-260C-1 YEAR	-40 to 125	240A2Q	<a href="#">Samples</a>
INA240A2QPWRQ1	ACTIVE	TSSOP	PW	8	2000	RoHS & Green	NIPDAU	Level-3-260C-168 HR	-40 to 125	Q240A2	<a href="#">Samples</a>
INA240A3EDRQ1	ACTIVE	SOIC	D	8	2500	RoHS & Green	NIPDAU	Level-2-260C-1 YEAR	-40 to 150	240A3E	<a href="#">Samples</a>
INA240A3QDRQ1	ACTIVE	SOIC	D	8	2500	RoHS & Green	NIPDAU	Level-2-260C-1 YEAR	-40 to 125	240A3Q	<a href="#">Samples</a>
INA240A3QPWRQ1	ACTIVE	TSSOP	PW	8	2000	RoHS & Green	NIPDAU	Level-3-260C-168 HR	-40 to 125	Q240A3	<a href="#">Samples</a>
INA240A4EDRQ1	ACTIVE	SOIC	D	8	2500	RoHS & Green	NIPDAU	Level-2-260C-1 YEAR	-40 to 150	240A4E	<a href="#">Samples</a>
INA240A4QDRQ1	ACTIVE	SOIC	D	8	2500	RoHS & Green	NIPDAU	Level-2-260C-1 YEAR	-40 to 125	240A4Q	<a href="#">Samples</a>
INA240A4QPWRQ1	ACTIVE	TSSOP	PW	8	2000	RoHS & Green	NIPDAU	Level-3-260C-168 HR	-40 to 125	Q240A4	<a href="#">Samples</a>

(1) The marketing status values are defined as follows:

**ACTIVE:** Product device recommended for new designs.

**LIFEBUY:** TI has announced that the device will be discontinued, and a lifetime-buy period is in effect.

**NRND:** Not recommended for new designs. Device is in production to support existing customers, but TI does not recommend using this part in a new design.

**PREVIEW:** Device has been announced but is not in production. Samples may or may not be available.

**OBSOLETE:** TI has discontinued the production of the device.

(2) **RoHS:** TI defines "RoHS" to mean semiconductor products that are compliant with the current EU RoHS requirements for all 10 RoHS substances, including the requirement that RoHS substance do not exceed 0.1% by weight in homogeneous materials. Where designed to be soldered at high temperatures, "RoHS" products are suitable for use in specified lead-free processes. TI may reference these types of products as "Pb-Free".

**RoHS Exempt:** TI defines "RoHS Exempt" to mean products that contain lead but are compliant with EU RoHS pursuant to a specific EU RoHS exemption.

**Green:** TI defines "Green" to mean the content of Chlorine (Cl) and Bromine (Br) based flame retardants meet JS709B low halogen requirements of <=1000ppm threshold. Antimony trioxide based flame retardants must also meet the <=1000ppm threshold requirement.

- (3) MSL, Peak Temp. - The Moisture Sensitivity Level rating according to the JEDEC industry standard classifications, and peak solder temperature.
- (4) There may be additional marking, which relates to the logo, the lot trace code information, or the environmental category on the device.
- (5) Multiple Device Markings will be inside parentheses. Only one Device Marking contained in parentheses and separated by a "-" will appear on a device. If a line is indented then it is a continuation of the previous line and the two combined represent the entire Device Marking for that device.
- (6) Lead finish/Ball material - Orderable Devices may have multiple material finish options. Finish options are separated by a vertical ruled line. Lead finish/Ball material values may wrap to two lines if the finish value exceeds the maximum column width.

**Important Information and Disclaimer:**The information provided on this page represents TI's knowledge and belief as of the date that it is provided. TI bases its knowledge and belief on information provided by third parties, and makes no representation or warranty as to the accuracy of such information. Efforts are underway to better integrate information from third parties. TI has taken and continues to take reasonable steps to provide representative and accurate information but may not have conducted destructive testing or chemical analysis on incoming materials and chemicals. TI and TI suppliers consider certain information to be proprietary, and thus CAS numbers and other limited information may not be available for release.

In no event shall TI's liability arising out of such information exceed the total purchase price of the TI part(s) at issue in this document sold by TI to Customer on an annual basis.

**OTHER QUALIFIED VERSIONS OF INA240-Q1 :**

- Catalog : [INA240](#)

NOTE: Qualified Version Definitions:

- Catalog - TI's standard catalog product

**TAPE AND REEL INFORMATION**

**QUADRANT ASSIGNMENTS FOR PIN 1 ORIENTATION IN TAPE**

\*All dimensions are nominal

Device	Package Type	Package Drawing	Pins	SPQ	Reel Diameter (mm)	Reel Width W1 (mm)	A0 (mm)	B0 (mm)	K0 (mm)	P1 (mm)	W (mm)	Pin1 Quadrant
INA240A1EDRQ1	SOIC	D	8	2500	330.0	12.4	6.4	5.2	2.1	8.0	12.0	Q1
INA240A1QDRQ1	SOIC	D	8	2500	330.0	12.4	6.4	5.2	2.1	8.0	12.0	Q1
INA240A1QPWRQ1	TSSOP	PW	8	2000	330.0	12.4	7.0	3.6	1.6	8.0	12.0	Q1
INA240A2EDRQ1	SOIC	D	8	2500	330.0	12.4	6.4	5.2	2.1	8.0	12.0	Q1
INA240A2QDRQ1	SOIC	D	8	2500	330.0	12.4	6.4	5.2	2.1	8.0	12.0	Q1
INA240A2QPWRQ1	TSSOP	PW	8	2000	330.0	12.4	7.0	3.6	1.6	8.0	12.0	Q1
INA240A3EDRQ1	SOIC	D	8	2500	330.0	12.4	6.4	5.2	2.1	8.0	12.0	Q1
INA240A3QDRQ1	SOIC	D	8	2500	330.0	12.4	6.4	5.2	2.1	8.0	12.0	Q1
INA240A3QPWRQ1	TSSOP	PW	8	2000	330.0	12.4	7.0	3.6	1.6	8.0	12.0	Q1
INA240A4EDRQ1	SOIC	D	8	2500	330.0	12.4	6.4	5.2	2.1	8.0	12.0	Q1
INA240A4QDRQ1	SOIC	D	8	2500	330.0	12.4	6.4	5.2	2.1	8.0	12.0	Q1
INA240A4QPWRQ1	TSSOP	PW	8	2000	330.0	12.4	7.0	3.6	1.6	8.0	12.0	Q1

**TAPE AND REEL BOX DIMENSIONS**

\*All dimensions are nominal

Device	Package Type	Package Drawing	Pins	SPQ	Length (mm)	Width (mm)	Height (mm)
INA240A1EDRQ1	SOIC	D	8	2500	340.5	336.1	25.0
INA240A1QDRQ1	SOIC	D	8	2500	340.5	336.1	25.0
INA240A1QPWRQ1	TSSOP	PW	8	2000	367.0	367.0	35.0
INA240A2EDRQ1	SOIC	D	8	2500	340.5	336.1	25.0
INA240A2QDRQ1	SOIC	D	8	2500	340.5	336.1	25.0
INA240A2QPWRQ1	TSSOP	PW	8	2000	853.0	449.0	35.0
INA240A3EDRQ1	SOIC	D	8	2500	340.5	336.1	25.0
INA240A3QDRQ1	SOIC	D	8	2500	340.5	336.1	25.0
INA240A3QPWRQ1	TSSOP	PW	8	2000	853.0	449.0	35.0
INA240A4EDRQ1	SOIC	D	8	2500	340.5	336.1	25.0
INA240A4QDRQ1	SOIC	D	8	2500	340.5	336.1	25.0
INA240A4QPWRQ1	TSSOP	PW	8	2000	853.0	449.0	35.0



D0008A

# PACKAGE OUTLINE

SOIC - 1.75 mm max height

SMALL OUTLINE INTEGRATED CIRCUIT



4214825/C 02/2019

### NOTES:

1. Linear dimensions are in inches [millimeters]. Dimensions in parenthesis are for reference only. Controlling dimensions are in inches. Dimensioning and tolerancing per ASME Y14.5M.
2. This drawing is subject to change without notice.
3. This dimension does not include mold flash, protrusions, or gate burrs. Mold flash, protrusions, or gate burrs shall not exceed  $.006$  [0.15] per side.
4. This dimension does not include interlead flash.
5. Reference JEDEC registration MS-012, variation AA.

# EXAMPLE BOARD LAYOUT

D0008A

SOIC - 1.75 mm max height

SMALL OUTLINE INTEGRATED CIRCUIT



LAND PATTERN EXAMPLE  
 EXPOSED METAL SHOWN  
 SCALE:8X



SOLDER MASK DETAILS

4214825/C 02/2019

NOTES: (continued)

- 6. Publication IPC-7351 may have alternate designs.
- 7. Solder mask tolerances between and around signal pads can vary based on board fabrication site.

# EXAMPLE STENCIL DESIGN

D0008A

SOIC - 1.75 mm max height

SMALL OUTLINE INTEGRATED CIRCUIT



SOLDER PASTE EXAMPLE  
BASED ON .005 INCH [0.125 MM] THICK STENCIL  
SCALE:8X

4214825/C 02/2019

NOTES: (continued)

8. Laser cutting apertures with trapezoidal walls and rounded corners may offer better paste release. IPC-7525 may have alternate design recommendations.
9. Board assembly site may have different recommendations for stencil design.

PW0008A



PACKAGE OUTLINE

TSSOP - 1.2 mm max height

SMALL OUTLINE PACKAGE

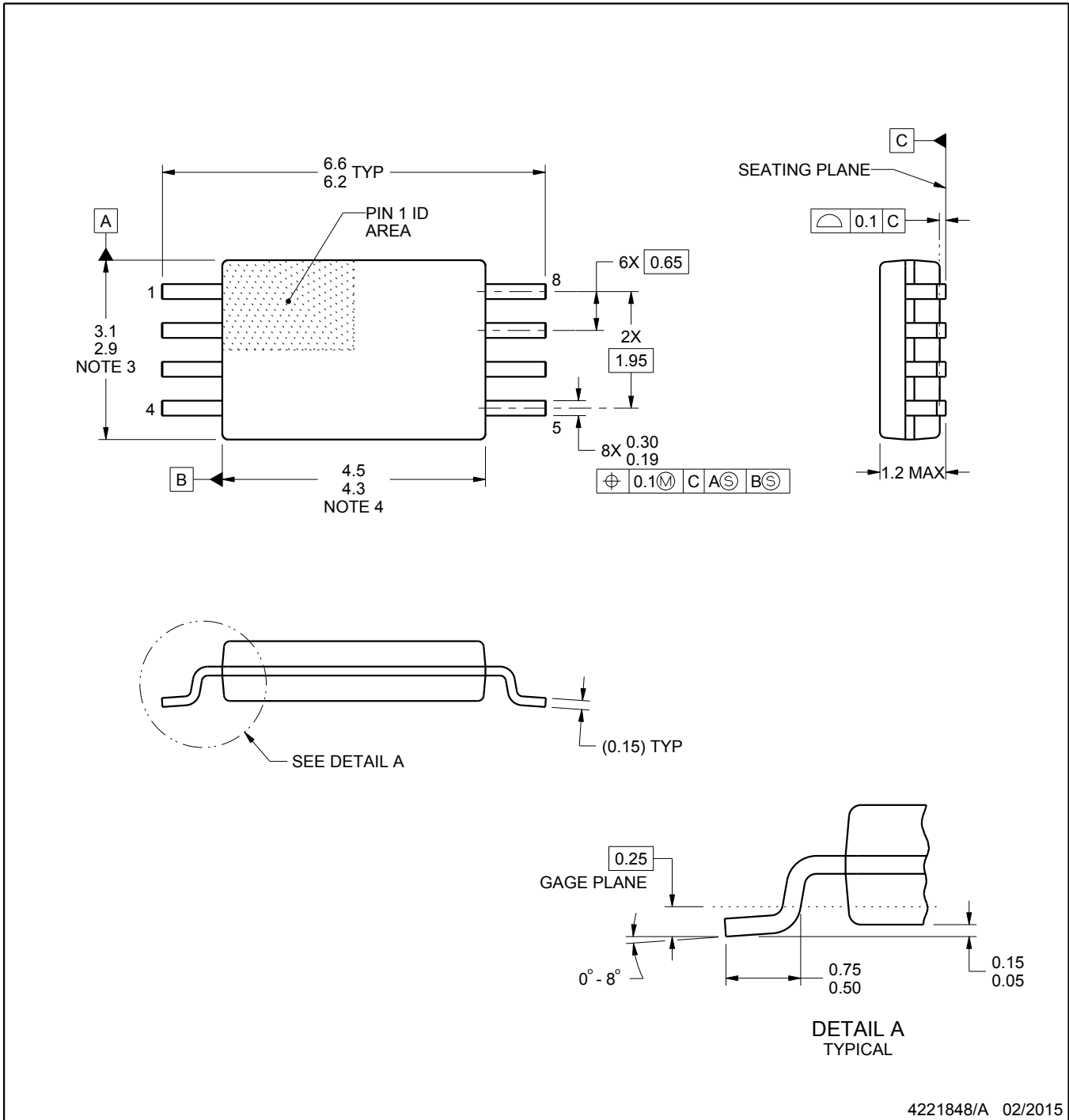

4221848/A 02/2015

NOTES:

1. All linear dimensions are in millimeters. Any dimensions in parenthesis are for reference only. Dimensioning and tolerancing per ASME Y14.5M.
2. This drawing is subject to change without notice.
3. This dimension does not include mold flash, protrusions, or gate burrs. Mold flash, protrusions, or gate burrs shall not exceed 0.15 mm per side.
4. This dimension does not include interlead flash. Interlead flash shall not exceed 0.25 mm per side.
5. Reference JEDEC registration MO-153, variation AA.

# EXAMPLE BOARD LAYOUT

PW0008A

TSSOP - 1.2 mm max height

SMALL OUTLINE PACKAGE

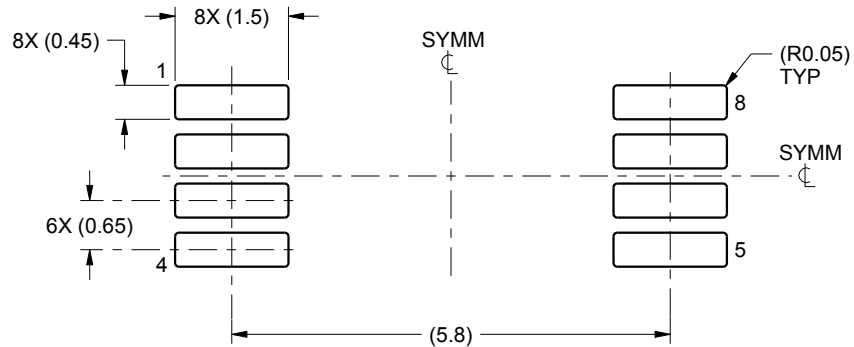

LAND PATTERN EXAMPLE  
SCALE:10X

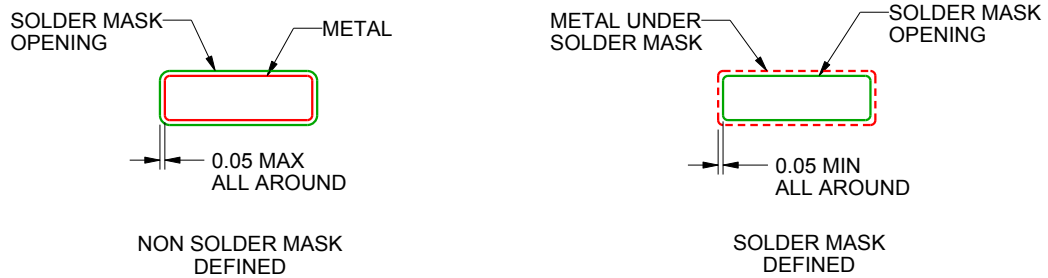

SOLDER MASK DETAILS  
NOT TO SCALE

4221848/A 02/2015

NOTES: (continued)

- 6. Publication IPC-7351 may have alternate designs.
- 7. Solder mask tolerances between and around signal pads can vary based on board fabrication site.

# EXAMPLE STENCIL DESIGN

PW0008A

TSSOP - 1.2 mm max height

SMALL OUTLINE PACKAGE



SOLDER PASTE EXAMPLE  
BASED ON 0.125 mm THICK STENCIL  
SCALE:10X

4221848/A 02/2015

NOTES: (continued)

8. Laser cutting apertures with trapezoidal walls and rounded corners may offer better paste release. IPC-7525 may have alternate design recommendations.
9. Board assembly site may have different recommendations for stencil design.

## 重要声明和免责声明

TI“按原样”提供技术和可靠性数据（包括数据表）、设计资源（包括参考设计）、应用或其他设计建议、网络工具、安全信息和其他资源，不保证没有瑕疵且不做任何明示或暗示的担保，包括但不限于对适销性、某特定用途方面的适用性或不侵犯任何第三方知识产权的暗示担保。

这些资源可供使用 TI 产品进行设计的熟练开发人员使用。您将自行承担以下全部责任：(1) 针对您的应用选择合适的 TI 产品，(2) 设计、验证并测试您的应用，(3) 确保您的应用满足相应标准以及任何其他功能安全、信息安全、监管或其他要求。

这些资源如有变更，恕不另行通知。TI 授权您仅可将这些资源用于研发本资源所述的 TI 产品的应用。严禁对这些资源进行其他复制或展示。您无权使用任何其他 TI 知识产权或任何第三方知识产权。您应全额赔偿因在这些资源的使用中对 TI 及其代表造成的任何索赔、损害、成本、损失和债务，TI 对此概不负责。

TI 提供的产品受 [TI 的销售条款](#) 或 [ti.com](#) 上其他适用条款/TI 产品随附的其他适用条款的约束。TI 提供这些资源并不会扩展或以其他方式更改 TI 针对 TI 产品发布的适用的担保或担保免责声明。

TI 反对并拒绝您可能提出的任何其他或不同的条款。

邮寄地址：Texas Instruments, Post Office Box 655303, Dallas, Texas 75265

Copyright © 2022，德州仪器 (TI) 公司