

TPS624xx-Q1 汽车 2.25MHz 固定输出电压双路降压转换器

1 特性

- 符合汽车类应用的要求
- 具有符合 AEC Q100 标准的下列结果：
 - 器件温度 1 级：-40°C 至 125°C 工作结温范围
 - 器件 HBM ESD 分类等级 2
 - 器件 CDM ESD 分类等级 C4B
- 高效 - 高达 95%
- V_{IN} 范围从 2.5V 至 6V
- 2.25MHz 固定频率运行
- 输出电流 TPS62406-Q1 1000mA/400mA
- 输出电流 TPS62407-Q1 400mA/600mA
- 输出电流 TPS62422-Q1 1000mA/600mA
- 输出电流 TPS62423-Q1 800mA/800mA
- 输出电流 TPS62424-Q1 800mA/800mA
- 固定输出电压
- EasyScale™ 可选单引脚串行接口
- 轻负载电流下的省电模式
- 180° 异相操作
- 脉宽调制模式下的输出电压精度 $\pm 1\%$
- 适用于两个转换器的典型 32 μ A 静态电流
- 可实现 100% 占空比，以确保最低压降

2 应用

- 汽车负载点稳压器
- ADAS 摄像头模块
- 镜片更换 (CMS)
- 信息娱乐系统与仪表组

简化原理图

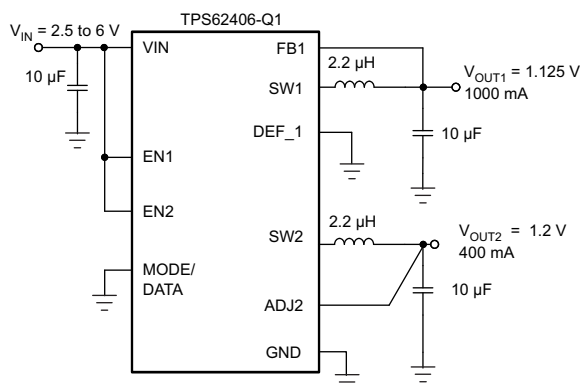

3 说明

TPS624xx-Q1 器件系列是适用于汽车应用（例如高级驾驶员辅助系统 (ADAS)）的同步双路降压直流/直流转换器。该系列可提供两组由标准 3.3V 或 5V 电压轨供电的独立输出电压轨，以及经过优化的固定输出电压，为 ADAS 摄像头模块中的 CMOS 成像仪或串行器-解串器供电。

该 EasyScale™ 串行接口允许在操作过程中修改输出电压。固定输出电压版本 TPS624xx-Q1 支持对低功耗处理器进行单引脚控制的简单动态电压调节。

TPS624xx-Q1 器件系列可在 2.25MHz 固定开关频率下运行，在轻负载电流情况下会进入省电模式，以便在整个负载电流范围内保持高效率。对于低噪声应用，用户可以通过将 MODE/DATA 引脚的电平拉高来强制器件进入固定频率 PWM 模式。关断模式可以将电流消耗降低至 1.2 μ A 的典型值。此器件允许使用小型电感器和电容器以实现一个小型解决方案尺寸。

器件信息(1)

器件型号	封装	封装尺寸 (标称值)
TPS62406-Q1	VSON (10)	3.00mm x 3.00mm
TPS62407-Q1		
TPS62422-Q1		
TPS62423-Q1		
TPS62424-Q1		

(1) 如需了解所有可用封装，请参阅产品说明书末尾的可订购产品附录。

TPS62406-Q1 效率与输出电流, V_{OUT2}

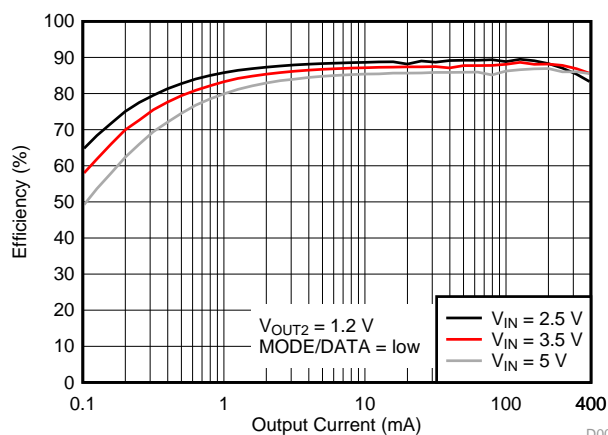

D002



目录

1	特性	1	8.4	Device Functional Modes	12
2	应用	1	8.5	Programming	14
3	说明	1	9	Application and Implementation	20
4	修订历史记录	2	9.1	Application Information	20
5	Device Comparison Table	3	9.2	Typical Application	20
6	Pin Configuration and Functions	3	9.3	System Examples	26
7	Specifications	4	10	Power Supply Recommendations	28
7.1	Absolute Maximum Ratings	4	11	Layout	28
7.2	ESD Ratings	4	11.1	Layout Guidelines	28
7.3	Recommended Operating Conditions	4	11.2	Layout Example	28
7.4	Thermal Information	5	12	器件和文档支持	29
7.5	Electrical Characteristics	5	12.1	相关链接	29
7.6	Timing Requirements	7	12.2	社区资源	29
7.7	Switching Characteristics	7	12.3	商标	29
7.8	Typical Characteristics	8	12.4	静电放电警告	29
8	Detailed Description	9	12.5	术语表	29
8.1	Overview	9	13	机械、封装和可订购信息	29
8.2	Functional Block Diagram	10	13.1	Package Option Addendum	30
8.3	Feature Description	11	13.2	Mechanical Data	33

4 修订历史记录

注：之前版本的页码可能与当前版本有所不同。

Changes from Original (December 2014) to Revision A	Page
• Changed the I_{OUT1} and I_{OUT2} current for the TPS62406-Q1 device in the <i>Device Comparison Table</i>	3
• Changed forward current limit PMOS and NMOS for the TPS62406-Q1	6

Changes from Revision A (October 2015) to Revision B	Page
• Changed I_{OUT1} for the TPS62406-Q1 device to 1000 mA in the <i>Electrical Characteristics</i> table	6

Changes from Revision B (October 2016) to Revision C	Page
• 修订版本 C 是产品说明书首次公开发布	1
• 已更改 更改了产品说明书标题；所有段落中的 TPS6240x-Q1 更改为 TPS624xx-Q1；修订了说明第一段中的 文本	1
• 已添加 将器件编号添加到了 特性 列表	1
• Added TPS62422-Q1, TPS62423-Q1, and TPS62424-Q1 devices to the <i>Design Requirements</i> section	20
• Added TPS62422-Q1 output voltage vs. output current characteristic	23
• Changed recommended layout example	28

Changes from Revision C (April 2018) to Revision D	Page
• 将 TPS62422-Q1、TPS62423-Q1 和 TPS62424-Q1 从产品预览 更改为生产	1

5 Device Comparison Table

PART NUMBER	DEFAULT OUTPUT VOLTAGE			OUTPUT CURRENT	
	V_{OUT1}	Fixed default	DEF_1 = High 1.125 V DEF_1 = Low 1.125 V	I_{OUT1}	1000 mA
TPS62406-Q1	V_{OUT2}	Fixed default 1.2 V		I_{OUT2}	400 mA
	V_{OUT1}	Fixed default	DEF_1 = High 1.225 V DEF_1 = Low 1.225 V	I_{OUT1}	400 mA
TPS62407-Q1	V_{OUT2}	Fixed default 1.85 V		I_{OUT2}	600 mA
	V_{OUT1}	Fixed default	DEF_1 = High 1.8 V DEF_1 = Low 1.15 V	I_{OUT1}	1000 mA
TPS62422-Q1	V_{OUT2}	Fixed default 1.2V		I_{OUT2}	600 mA
	V_{OUT1}	Fixed default	DEF_1 = High 1.5 V DEF_1 = Low 1.2 V	I_{OUT1}	800 mA
TPS62423-Q1	V_{OUT2}	Fixed default 1.8V		I_{OUT2}	800 mA
	V_{OUT1}	Fixed default	DEF_1 = High 1.3 V DEF_1 = Low 1.1 V	I_{OUT1}	800 mA
TPS62424-Q1	V_{OUT2}	Fixed default 1.8V		I_{OUT2}	800 mA

6 Pin Configuration and Functions

**DRC Package
10-Pin VSON With Thermal Pad
Top View**

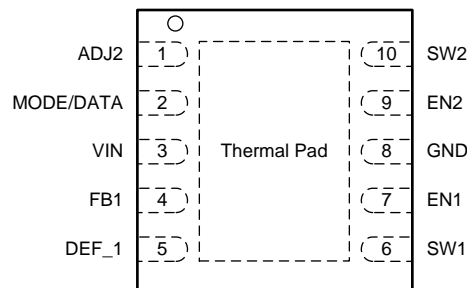

Pin Functions

PIN		I/O	DESCRIPTION
NAME	NO.		
ADJ2	1	I	Output voltage sense pin for the internal feedback divider. This pin must connect directly to the output. If using the EasyScale interface-on converter 2, this pin must also connect directly to the output.
DEF_1	5	I	This pin defines the output voltage of converter 1 and is a digital input, that selects between two fixed default output voltages. See Device Comparison Table for output voltage setting of the different device options. For TPS62406-Q1 and TPS62407-Q1 the output voltage is same independent of DEF_1 pin level. This pin must be terminated.
EN1	7	I	Enable input for converter 1, active-high. This pin must be terminated.
EN2	9	I	Enable input for converter 2, active-high. This pin must be terminated.
FB1	4	I	Output voltage sense pin for the internal feedback divider. This pin is connected to the output.
GND	8	—	GND for both converters; connect this pin to the thermal pad.

Pin Functions (continued)

PIN		I/O	DESCRIPTION
NAME	NO.		
MODE/DATA	2	I/O	This pin has two functions: <ol style="list-style-type: none"> 1. Operation-mode selection: With low level, enables power-save mode where the device operates in PFM mode at light loads and automatically enters PWM mode at heavy loads. Pulling this PIN to high forces the device to operate in PWM mode over the whole load range. 2. EasyScale interface function: One-wire serial interface to change the output voltage of both converters. The pin has an open-drain output to provide an acknowledge condition if requested. The current into the open-drain output stage may not exceed 500 μA. The EasyScale interface is active if either EN1 or EN2 is high.
SW1	6	I/O	Switch pin of converter 1. Connect to inductor
SW2	10	I/O	Switch pin of converter 2. Connect to inductor
VIN	3	I	Input pin, connect to supply or battery voltage, 2.5 V to 6 V. Connect the input capacitor C_{IN} as close as possible between VIN pin and GND pin.
Thermal pad		—	Connect to GND

7 Specifications

7.1 Absolute Maximum Ratings

 over operating junction temperature range (unless otherwise noted)⁽¹⁾

		MIN	MAX	UNIT
Input voltage ⁽²⁾	VIN	−0.3	7	V
Voltage ⁽²⁾	EN, MODE/DATA, DEF_1	−0.3	$V_{IN} + 0.3, \leq 7$	V
	SW1, SW2	−0.3	7	V
	ADJ2, FB1	−0.3	$V_{IN} + 0.3, \leq 7$	V
Current	MODE/DATA		≤ 0.5	mA
Maximum operating junction temperature, T_{jmax}			150	°C
Storage temperature, T_{stg}		−65	150	°C

(1) Stresses beyond those listed under *Absolute Maximum Ratings* may cause permanent damage to the device. These are stress ratings only, and do not imply functional operation of the device at these or any other conditions beyond those indicated under *Recommended Operating Conditions*. Exposure to absolute-maximum-rated conditions for extended periods may affect device reliability.

(2) All voltage values are with respect to the network ground terminal.

7.2 ESD Ratings

		VALUE	UNIT
$V_{(ESD)}$ Electrostatic discharge	Human body model (HBM), per AEC Q100-002 ⁽¹⁾	± 2000	V
	Charged device model (CDM), per AEC Q100-011	All pins	± 500
		Corner pins (1, 5, 6, and 10)	± 750

(1) AEC Q100-002 indicates HBM stressing is done in accordance with the ANSI/ESDA/JEDEC JS-001 specification.

7.3 Recommended Operating Conditions

over operating junction temperature range (unless otherwise noted)

	MIN	MAX	UNIT
V_{IN} Supply voltage	2.5	6	V
T_J Operating junction temperature	−40	125	°C

7.4 Thermal Information

THERMAL METRIC ⁽¹⁾		TPS624xx-Q1	UNIT
		DRC (VSON)	
		10 PINS	
R _{θJA}	Junction-to-ambient thermal resistance	42.7	°C/W
R _{θJC(top)}	Junction-to-case (top) thermal resistance	46.9	°C/W
R _{θJB}	Junction-to-board thermal resistance	18.1	°C/W
ψ _{JT}	Junction-to-top characterization parameter	0.5	°C/W
ψ _{JB}	Junction-to-board characterization parameter	18.3	°C/W
R _{θJC(bot)}	Junction-to-case (bottom) thermal resistance	3.1	°C/W

(1) For more information about traditional and new thermal metrics, see the *Semiconductor and IC Package Thermal Metrics* application report, [SPRA953](#).

7.5 Electrical Characteristics

V_{IN} = 3.6 V, EN1 = EN2 = V_{IN}, MODE = GND, L1 = L2 = 2.2 μH, C_{OUT1} = C_{OUT2} = 20 μF, T_J = –40°C to 125°C, typical values are at T_J = 25°C (unless otherwise noted)

PARAMETER		TEST CONDITIONS	MIN	TYP	MAX	UNIT
SUPPLY CURRENT						
V _{IN}	Input voltage range		2.5		6	V
I _Q	Operating quiescent current	One converter, no load on the output. PFM mode enabled (MODE/DATA = GND) device not switching, EN1 = 1 or EN2 = 1		19	35	μA
		Two converters, no load on the output. PFM mode enabled (MODE/DATA = GND) device not switching, EN1 = EN2 = 1		32	50	
		No load on the output, MODE/DATA = GND, for one converter ⁽¹⁾		23		
		No load on the output, MODE/DATA = V _{IN} , for one converter ⁽¹⁾		3.6		mA
I _{SD}	Shutdown current	EN1, EN2 = GND, V _{IN} = 3.6 V ⁽²⁾		1.2	3	μA
		EN1, EN2 = GND, V _{IN} ramped from 0 V to 3.6 V ⁽³⁾		0.1	1.5	
V _{UVLO}	Undervoltage lockout threshold	Falling		1.5	2.35	V
		Rising			2.4	
ENABLE EN1, EN2						
V _{IH}	High-level input voltage range, EN1, EN2		1.2		V _{IN}	V
V _{IL}	Low-level input voltage range, EN1, EN2		0		0.4	V
I _{IN}	Input bias current, EN1, EN2	EN1, EN2 = GND or V _{IN}		0.05	1	μA
DEF_1 INPUT						
V _{DEF_1H}	DEF_1 high-level digital input voltage range		0.9		V _{IN}	V
V _{DEF_1L}	DEF_1 low-level digital input voltage range		0		0.4	V
I _{IN}	Input bias current DEF_1	DEF_1 = GND or V _{IN}		0.01	1	μA
MODE/DATA						
V _{IH}	High-level input voltage range, MODE/DATA		1.2		V _{IN}	V
V _{IL}	Low-level input voltage range, MODE/DATA		0		0.4	V
I _{IN}	Input bias current, MODE/DATA	MODE/DATA = GND or V _{IN}		0.01	1	μA
V _{OH}	Acknowledge output voltage high	Open drain, through external pullup resistor			V _{IN}	V
V _{OL}	Acknowledge output voltage low	Open drain, sink current 500 μA	0		0.4	V
POWER SWITCH						
r _{DS(on)}	P-channel MOSFET on-resistance, converter 1 and 2	V _{IN} = V _{GS} = 3.6 V		280	620	mΩ
I _{LK_P MOS}	P-channel leakage current	V _{DS} = 6 V			1	μA

(1) Device is switching with no load on the output, L1 = L2 = 3.3 μH, value includes losses of the coil.

(2) These values are valid after enabling the device one time (EN1 or EN2 = high) and maintaining supply voltage V_{IN}.

(3) These values are valid when the device is disabled (EN1 and EN2 low) and supply voltage V_{IN} is powered up. The values remain valid until enabling the device the first time (EN1 or EN2 = high). After the first enable, Note 3 becomes valid.

Electrical Characteristics (continued)

$V_{IN} = 3.6\text{ V}$, $EN1 = EN2 = V_{IN}$, $MODE = GND$, $L1 = L2 = 2.2\ \mu\text{H}$, $C_{OUT1} = C_{OUT2} = 20\ \mu\text{F}$, $T_J = -40^\circ\text{C}$ to 125°C , typical values are at $T_J = 25^\circ\text{C}$ (unless otherwise noted)

PARAMETER		TEST CONDITIONS	MIN	TYP	MAX	UNIT	
$r_{DS(on)}$	N-channel MOSFET on-resistance converter 1 and 2	$V_{IN} = V_{GS} = 3.6\text{ V}$		200	450	m Ω	
$I_{LK_SW1/SW2}$	Leakage current into SW1 or SW2 pin	Includes N-channel leakage current, $V_{IN} = \text{open}$, $V_{SW} = 6\text{ V}$, $EN = GND^{(4)}$		6	7.5	μA	
I_{LIMF}	Forward current limit PMOS and NMOS	TPS62406-Q1 V_{OUT1}	$2.5\text{ V} \leq V_{IN} \leq 6\text{ V}$	1.18	1.4	1.61	A
		TPS62406-Q1 V_{OUT2}	$2.5\text{ V} \leq V_{IN} \leq 6\text{ V}$	0.68	0.8	0.92	
		TPS62407-Q1 V_{OUT1}	$2.5\text{ V} \leq V_{IN} \leq 6\text{ V}$	0.68	0.8	0.92	
		TPS62407-Q1 V_{OUT2}	$2.5\text{ V} \leq V_{IN} \leq 6\text{ V}$	0.75	1	1.15	
		TPS62422-Q1 V_{OUT1}	$2.5\text{ V} \leq V_{IN} \leq 6\text{ V}$	1.18	1.4	1.61	
		TPS62422-Q1 V_{OUT2}	$2.5\text{ V} \leq V_{IN} \leq 6\text{ V}$	0.75	1	1.15	
		TPS62423-Q1 V_{OUT1}	$2.5\text{ V} \leq V_{IN} \leq 6\text{ V}$	1	1.2	1.38	
		TPS62423-Q1 V_{OUT2}	$2.5\text{ V} \leq V_{IN} \leq 6\text{ V}$	1	1.2	1.38	
		TPS62424-Q1 V_{OUT1}	$2.5\text{ V} \leq V_{IN} \leq 6\text{ V}$	1	1.2	1.38	
		TPS62424-Q1 V_{OUT2}	$2.5\text{ V} \leq V_{IN} \leq 6\text{ V}$	1	1.2	1.38	
T_{SD}	Thermal shutdown	Increasing junction temperature		150		$^\circ\text{C}$	
	Thermal shutdown hysteresis	Decreasing junction temperature		20		$^\circ\text{C}$	
OUTPUT							
V_{ref}	Internal Reference voltage			600		mV	
$V_{OUTx(PFM)}$	DC output voltage accuracy	Voltage positioning active, $MODE/DATA = GND$, device operating in PFM mode, $V_{IN} = 2.5\text{ V}$ to $5\text{ V}^{(5)(6)}$	-1.5%	1%	2.5%		
$V_{OUTx(PWM)}$		$MODE/DATA = GND$; device operating in PWM mode, $V_{IN} = 2.5\text{ V}$ to $6\text{ V}^{(6)}$	-1%	0%	1%		
		$V_{IN} = 2.5\text{ V}$ to 6 V , $MODE/DATA = V_{IN}$, Fixed PWM operation, $0\text{ mA} < I_{OUT1} < 400\text{ mA}$; $0\text{ mA} < I_{OUT2} < 600\text{ mA}^{(7)}$	-1%	0%	1%		
	DC output voltage load regulation	PWM operation mode			0.5	%/A	

(4) An internal resistor of $1\text{ M}\Omega$ connects pins SW1 and SW2 to GND.

(5) Configuration L1 or L2 typ. $2.2\ \mu\text{H}$, C_{OUTx} typ $20\ \mu\text{F}$. See parameter measurement information, the output voltage ripple in PFM mode depends on the effective capacitance of the output capacitor; larger output capacitors lead to tighter output voltage tolerance.

(6) In power-save mode, the device typically enters PWM operation at $I_{PSM} = V_{IN} / 32\ \Omega$.

(7) For $V_{OUTx} > 2\text{ V}$, $V_{IN\ min} = V_{OUTx} + 0.5\text{ V}$

7.6 Timing Requirements

		MIN	NOM	MAX	UNIT
INTERFACE TIMING					
t_{Start}	Start time	2			μs
t_{H_LB}	High-time low bit, logic 0 detection	Signal level on MODE/DATA pin is > 1.2 V	2	200	μs
t_{L_LB}	Low-time low bit, logic 0 detection	Signal level on MODE/DATA pin < 0.4 V	$2 \times t_{H_LB}$	400	μs
t_{L_HB}	Low-time high bit, logic 1 detection	Signal level on MODE/DATA pin < 0.4 V	2	200	μs
t_{H_HB}	High-time high bit, logic 1 detection	Signal level on MODE/DATA pin is > 1.2 V	$2 \times t_{L_HB}$	400	μs
t_{EOS}	End of stream		2		μs
t_{ACKN}	Duration of acknowledge condition (MODE/DATA line pulled low by the device)	V_{IN} 2.5 V to 6 V	400	520	μs
t_{valACK}	Acknowledge valid time			2	μs
$t_{timeout}$	Time-out for entering power-save mode	MODE/DATA pin changes from high to low		520	μs

7.7 Switching Characteristics

$V_{IN} = 3.6$ V, $EN1 = EN2 = V_{IN}$, $MODE = GND$, $L1 = L2 = 2.2$ μH , $C_{OUT1} = C_{OUT2} = 20$ μF , $T_J = -40^\circ C$ to $125^\circ C$, typical values are at $T_J = 25^\circ C$ (unless otherwise noted)

PARAMETER	TEST CONDITIONS	MIN	TYP	MAX	UNIT	
OSCILLATOR						
f_{SW}	Oscillator frequency	$3 V \leq V_{IN} \leq 6 V^{(1)}$	2	2.25	2.7	MHz
OUTPUT						
$t_{Start\ up}$	Start-up time	Activation time to start switching ⁽²⁾	170		μs	
t_{Ramp}	V_{OUTx} ramp-up time	Time to ramp from 5% to 95% of V_{OUTx}	750		μs	

(1) For $V_{OUTx} > 2$ V, $V_{IN\ min} = V_{OUTx} + 0.5$ V

(2) This time is valid if one converter turns from shutdown mode ($EN2 = 0$) to active mode ($EN2 = 1$) with the other converter already enabled (for example, $EN1 = 1$). In case both converters are turned from shutdown mode ($EN1$ and $EN2 = 0$) to active mode ($EN1$ and/or $EN2 = 1$), a typical value of typ 80 μs for ramp up of internal circuits must be added. After t_{Start} , the converter starts switching and ramps V_{OUTx} .

7.8 Typical Characteristics

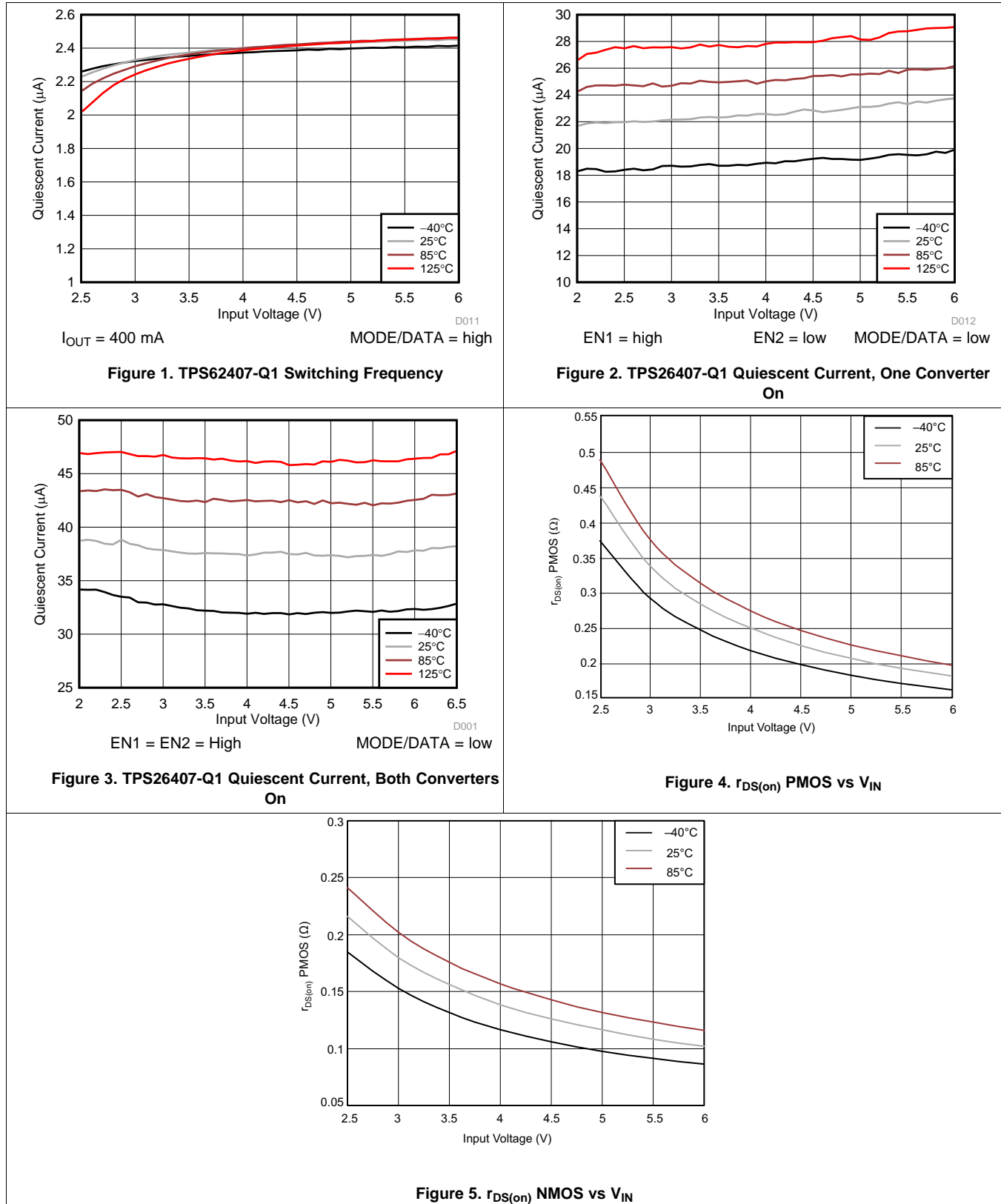

8 Detailed Description

8.1 Overview

The TPS624xx-Q1 device includes two synchronous step-down converters. The converters operate with typically 2.25-MHz fixed-frequency pulse-width modulation (PWM) at moderate to heavy load currents. With the power-save mode enabled, the converters automatically enter power-save mode at light load currents and operate in PFM (pulse frequency modulation).

During PWM operation, the converters use a unique fast-response voltage-mode controller scheme with input-voltage feed-forward to achieve good line and load regulation, allowing the use of small ceramic input and output capacitors. At the beginning of each clock cycle initiated by the clock signal, the P-channel MOSFET switch turns on and the inductor current ramps up until the comparator trips and the control logic turns off the switch.

Each converter integrates two current limits, one in the P-channel MOSFET and another one in the N-channel MOSFET. When the current in the P-channel MOSFET reaches its current limit, the P-channel MOSFET turns off and the N-channel MOSFET turns on. If the current in the N-channel MOSFET is above the N-MOS current limit threshold, the N-channel MOSFET remains on until the current drops below its current limit.

The two DC-DC converters operate synchronized to each other. A 180° phase shift between converter 1 and converter 2 decreases the input rms current.

8.1.1 Converter 1

It is possible to change the output voltage of converter 1 with the EasyScale serial Interface. This makes the device very flexible for output-voltage adjustment. In this case, the device uses an internal resistor network.

The output voltage can also be selected using the DEF_1 pin configuration as a digital input. For these voltage version the DEF_1 pin select the same output voltage for DEF_1=high or DEF_1=low.

8.1.2 Converter 2

It is also possible to change the output voltage of converter 2 via the EasyScale interface.

8.2 Functional Block Diagram

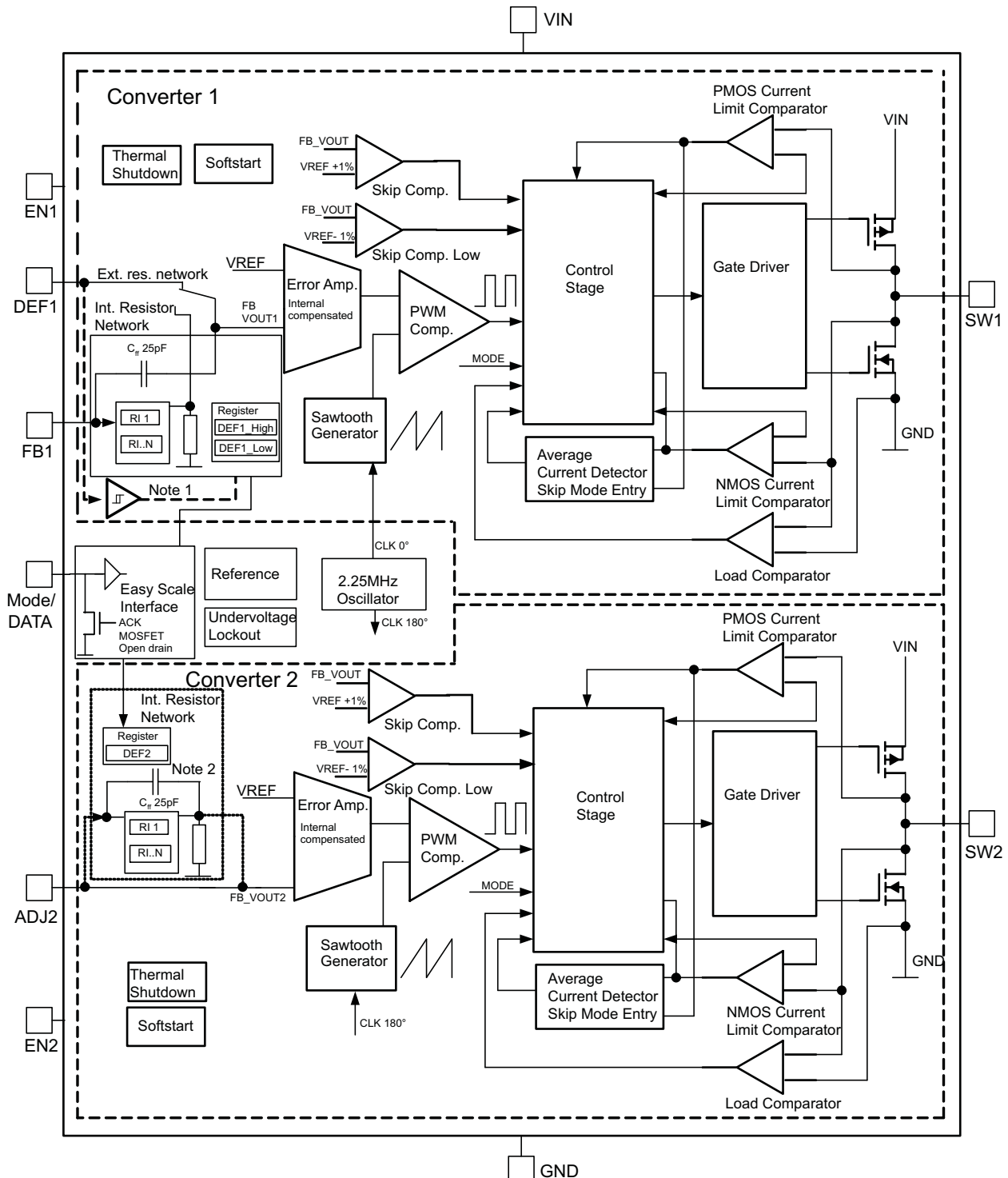

- (1) In the fixed output-voltage version, the DEF_1 pin connects to an internal digital input and disconnects from the error amplifier.
- (2) To set the output voltage of converter 2 through the EasyScale™ interface, the ADJ2 pin must directly connect to V_{OUT2}.

8.3 Feature Description

8.3.1 Enable

The device has a separate EN pin for each converter to start up each converter independently. If EN1 or EN2 is set to high, the corresponding converter starts up with soft start.

Pulling EN1 and EN2 pin low forces the device into shutdown, with a shutdown quiescent current of typically 1.2 μ A. In this mode, the P- and N-channel MOSFETs turn off and the entire internal control circuitry switches off. For proper operation, terminate the EN1 and EN2 pins, do not leave them floating.

8.3.2 DEF_1 Pin Function

The DEF_1 pin, dedicated to converter 1, makes the output voltage selection very flexible to support dynamic voltage management. Having this pin tied to a low level sets the output voltage according to the value in register REG_DEF_1_Low. The default voltage is 1.125 V for TPS62406-Q1. Having the pin tied to a high level sets the output voltage according to the value in register REG_DEF_1_High. The default value in this case is 1.125 V as well. The level of the DEF_1 pin selects between the two registers, REG_DEF_1_Low and REG_DEF_1_High, for the output-voltage setting. One can change the content of each register (and therefore output voltage) individually through the EasyScale interface. This makes the device very flexible in terms of output voltage setting; see [Table 3](#)

8.3.3 180° Out-of-Phase Operation

In PWM mode, the converters operate with a 180° turn-on phase shift of the PMOS (high side) transistors. This prevents the high-side switches of both converters from turning on simultaneously, reducing the input current ripple. This feature reduces the surge current drawn from the supply.

8.3.4 Short-Circuit Protection

Both outputs are short-circuit protected with maximum output current = I_{LIMF} (P-MOS and N-MOS). Once the PMOS switch reaches its current limit, it turns off and the NMOS switch turns on. The PMOS only turns on again once the current in the NMOS decreases below the NMOS current limit.

8.3.5 Thermal Shutdown

As soon as the junction temperature, T_j , exceeds 150°C (typical) the device goes into thermal shutdown. In this mode, the P- and N-channel MOSFETs turn off. The device continues its operation when the junction temperature falls below the thermal-shutdown hysteresis.

8.3.6 EasyScale Interface: One-Pin Serial Interface for Dynamic Output-Voltage Adjustment

8.3.6.1 General

The EasyScale interface is a simple but very flexible one-pin interface to configure the output voltage of both DC-DC converters. A master-slave structure is the basis of the interface, where the master is typically a microcontroller or application processor. [Figure 8](#) and [Table 2](#) give an overview of the protocol. The protocol consists of a device-specific address byte and a data byte. The device-specific address byte is fixed to 4E hex. The data byte consists of five bits for information, two address bits, and the RFA bit. The RFA bit set to high indicates the request-for-acknowledge condition. The acknowledge condition only applies after correct reception of the protocol.

The advantage of the EasyScale interface compared to other one-pin interfaces is that its bit detection is to a large extent independent from the bit transmission rate. It can automatically detect bit rates between 1.7 kb/s and up to 160 kb/s. Furthermore, the interface shares the MODE/DATA pin and requires no additional pin.

8.3.6.2 Protocol

Transmission of all bits is MSB first and LSB last. [Figure 9](#) shows the protocol without the acknowledge request (bit RFA = 0), [Figure 10](#) with the acknowledge request (bit RFA = 1).

Feature Description (continued)

Prior to both bytes, device address byte and data byte, one must apply a start condition. For this, pull the MODE/DATA pin high for at least t_{Start} before the bit transmission starts with the falling edge. In case the MODE/DATA line was already at a high level (forced PWM mode selection), the device requires no start condition prior to the device address byte.

Close the transmission of each byte with an end-of-stream condition for at least t_{EOS} .

8.4 Device Functional Modes

8.4.1 Power-Save Mode

Setting the MODE/DATA pin to low for both converters enables power-save mode. If the load current of a converter decreases, this converter enters power-save-mode operation automatically. The transition of a converter to power-save mode is independent from the operating condition of the other converter. During power-save mode, the converter operates with reduced switching frequency in PFM mode and with a minimum quiescent current to maintain high efficiency. The converter positions the output voltage in PFM mode to typically 1% above nominal V_{OUTx} . This voltage positioning feature minimizes voltage drops caused by a sudden load step.

In order to optimize the converter efficiency at light load, the device monitors average inductor current. The device changes from PWM mode to power-save mode if in PWM mode the inductor current falls below a certain threshold. The typical output current threshold, which one can calculate using [Equation 1](#) for each converter, depends on V_{IN} .

Equation 1: Average output current threshold to enter PFM mode

$$I_{\text{OUT_PFM_enter}} = \frac{V_{\text{IN_DCDC}}}{32 \, \Omega} \quad (1)$$

Equation 2: Average output current threshold to leave PFM mode

$$I_{\text{OUT_PFM_leave}} = \frac{V_{\text{IN_DCDC}}}{24 \, \Omega} \quad (2)$$

To keep the output-voltage ripple in power-save mode low, a single threshold comparator (skip comparator) monitors the output voltage. As the output voltage falls below the skip-comparator threshold (skip comp) of 1% above nominal V_{OUTx} , the corresponding converter starts switching for a minimum time period of typically 1 μs and provides current to the load and the output capacitor. Therefore, the output voltage increases and the device maintains switching until the output voltage trips the skip comparator threshold (skip comp) again. At this moment, all switching activity stops and the quiescent current reduces to minimum. The output capacitor supplies the load until the output voltage has dropped below the threshold again. Hereupon, the device starts switching again.

The converter leaves power-save mode and enters PWM mode if the output current exceeds the $I_{\text{OUT_PFM_leave}}$ current or if the output voltage falls below a second comparator threshold, called the skip-comparator-low (Skip Comp Low) threshold. This skip-comparator-low threshold is 2% below nominal V_{OUTx} and enables a fast transition from power-save mode to PWM mode during a load step.

Power-save mode typically reduces the quiescent current to 19 μA for one converter and 32 μA for both converters active. This single-skip comparator threshold method in power-save mode results in a very low output-voltage ripple. The ripple depends on the comparator delay and the size of the output capacitor. Increasing output capacitor values minimizes the output ripple. One can disable the power-save mode by setting the MODE/DATA pin to high. Both converters then operate in fixed PWM mode. Power-save mode enable or disable applies to both converters.

8.4.1.1 Dynamic Voltage Positioning

This feature reduces the voltage under- and overshoots at load steps from light to heavy load and from heavy to light load. Power-save-mode operation activates dynamic voltage positioning and provides more headroom for both the voltage drop at a load step and the voltage increase when a load is switched off, which improves load-transient behavior.

Device Functional Modes (continued)

At light loads, in which the converter operates in PFM mode, the output voltage regulation is typically 1% higher than the nominal value. In case of a load transient from light load to heavy load, the output voltage drops until it reaches the skip comparator low threshold set to 2% below the nominal value and enters PWM mode. During a load transition from heavy load to light load, the device also minimizes voltage overshoot because of active regulation turning on the N-channel switch.

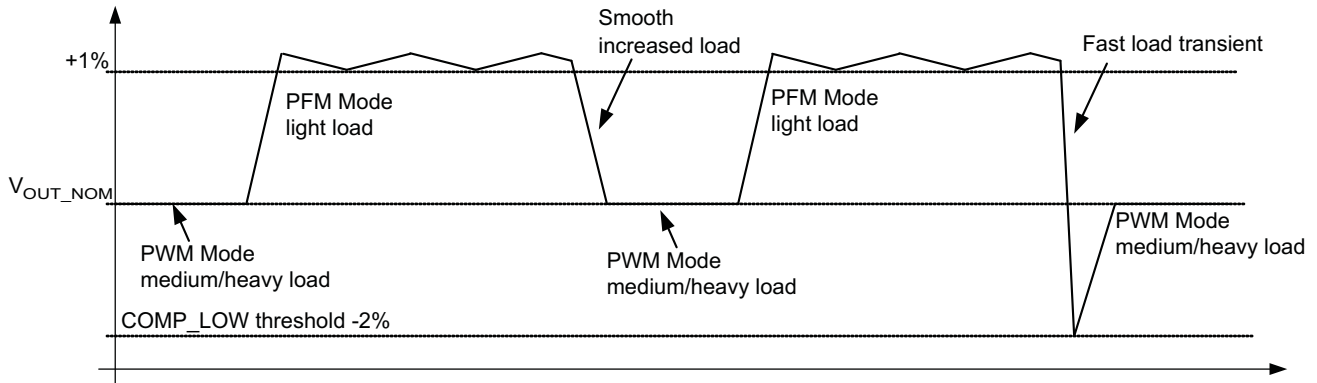

Figure 6. Dynamic Voltage Positioning

8.4.1.2 Soft Start

The two converters have an internal soft-start circuit that limits the inrush current during startup. Figure 7 shows control of the output-voltage ramp-up during soft start.

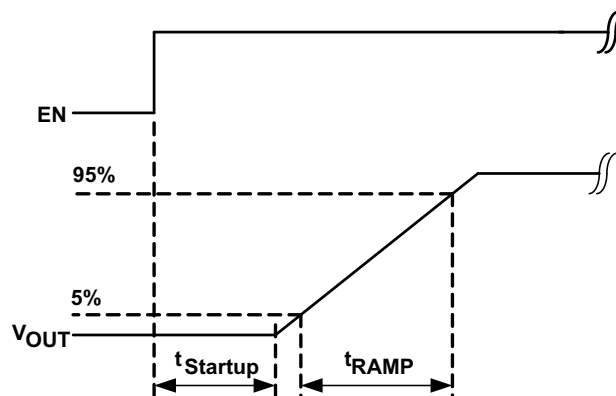

Figure 7. Soft Start

8.4.1.3 100% Duty-Cycle Low-Dropout Operation

The converters offer a low input-to-output voltage difference while still maintaining operation with the use of the 100% duty-cycle mode. In this mode, the P-channel switch is constantly on. This is particularly useful in battery-powered applications to achieve longest operation time by taking full advantage of the whole battery-voltage range. The minimum input voltage to maintain regulation depends on the load current and output voltage, which one can calculate as:

$$V_{in_{min}} = V_{out_{max}} + I_{out_{max}} \times (R_{DS(on)_{max}} + R_L)$$

with

- $I_{OUTx_{max}}$ = maximum output current plus inductor ripple current
- $r_{DS(on)_{max}}$ = maximum P-channel switch $r_{DS(on)}$
- R_L = dc resistance of the inductor
- $V_{OUTx_{max}}$ = nominal output voltage plus maximum output-voltage tolerance (3)

Device Functional Modes (continued)

With decreasing load current, the device automatically switches into pulse-skipping operation, in which the power stage operates intermittently based on load demand. Running cycles periodically minimizes the switching losses, and the device runs with a minimum quiescent current, maintaining high efficiency.

8.4.1.4 Undervoltage Lockout

The undervoltage lockout circuit prevents the device from malfunction at low input voltages and from excessive discharge of the battery, and disables the converters. The undervoltage lockout threshold is typically 1.5 V; maximum of 2.35 V. In case the interface overwrites the default register values, the new values in the registers REG_DEF_1_High, REG_DEF_1_Low and REG_DEF_2 remain valid as long the supply voltage does not fall below the undervoltage lockout threshold, independent of disabling of the converters.

8.4.2 Mode Selection

The MODE/DATA pin allows mode selection between forced PWM mode and power-save mode for both converters. Furthermore, this pin is a multipurpose pin and provides (besides mode selection) a one-pin interface to receive serial data from a host to set the output voltage, as described in the [EasyScale Interface](#) section.

Connecting this pin to GND enables the automatic PWM and power-save-mode operation. The converters operate in fixed-frequency PWM mode at moderate-to-heavy loads, and in the PFM mode during light loads, maintaining high efficiency over a wide load-current range.

Pulling the MODE/DATA pin high forces both converters to operate constantly in the PWM mode, even at light load currents. The advantage is that the converters operate with a fixed frequency, allowing simple filtering of the switching frequency for noise-sensitive applications. In this mode, the efficiency is lower compared to the power-save mode during light loads. For additional flexibility, it is possible to switch from power-save mode to forced PWM mode during operation. This allows efficient power management by adjusting the operation of the converter to the specific system requirements.

In the case of changing the operation mode from forced PWM mode (MODE/DATA = high) to power-save mode (MODE/DATA = 0), enabling the power-save mode occurs after a delay time of t_{timeout} , which is 520 μs maximum.

Setting the MODE/DATA to 1 enables forced-PWM-mode operation immediately.

8.5 Programming

8.5.1 Addressable Registers

Three registers with a data content of 5 bits are addressable. With 5-bit data content, 32 different values for each register are available. [Table 1](#) shows the addressable registers to set the output voltage when the DEF_1 pin works as a digital input. In this case, converter 1 has a related register for each DEF_1 pin condition, and one register for converter 2. A high or low condition on pin DEF_1 selects either the content of register REG_DEF_1_High or REG_DEF_1_Low, thus setting the output voltage of converter 1 according to the values in Selectable Output Voltage Converter 1, With Pin DEF_1 as Digital Input. Use of a precise internal resistor divider network to generate these output voltages makes external resistors unnecessary (less board space) and provides higher output-voltage accuracy. Enabling at least one of the converters (EN1 or EN2 is high) activates the interface. After the startup time t_{Start} (170 μs), the interface is ready for data reception.

Table 1. Addressable Registers for Default Fixed-Output Voltage Options (PIN DEF_1 = Digital Input)

DEVICE	REGISTER	DESCRIPTION	DEF_1 PIN	A1	A0	D4	D3	D2	D1	D0
TPS624xx-Q1 ,	REG_DEF_1_High	Converter 1 output voltage setting for DEF_1 = High condition. The content of the register is active with the DEF_1 pin high.	High	0	1	Output voltage setting, see Table 3				
	REG_DEF_1_Low	Converter 1 output voltage setting for DEF_1 = Low condition.	Low	0	0	Output voltage setting, see Table 3				
	REG_DEF_2	Converter 2 output voltage	Not applicable	1	0	Output voltage setting, see Table 4				
		Do not use			1	1				

8.5.1.1 Bit Decoding

The bit detection is based on a PWM scheme, where the criterion is the relation between the low time and high time of the low or high bit (t_{L_xB} and t_{H_xB}). Bit detection can be simplified to:

High bit: $t_{H_HB} > t_{L_HB}$, but with t_{H_HB} at least $2 \times t_{L_HB}$, see [Figure 8](#).

Low bit: $t_{L_LB} > t_{H_LB}$, but with t_{L_LB} at least $2 \times t_{H_LB}$, see [Figure 8](#).

The bit detection starts with a falling edge on the MODE/DATA pin and ends with the next falling edge. Detection of a 0 or 1 depends on the relation between t_{L_xB} and t_{H_xB} .

8.5.1.2 Acknowledge

The device only applies the acknowledge condition if all of the following occurs:

- A set RFA bit requests an acknowledge
- The transmitted device address matches with the device address of the device
- Correct reception of 16 bits occurred

In this case, the device turns on the internal ACKN-MOSFET and pulls the MODE/DATA pin low for the time t_{ACKN} , which is 520 μ s maximum. The acknowledge condition is valid after an internal delay time t_{valACK} . This means the internal ACKN-MOSFET turns on after t_{valACK} , on detection of the last falling edge of the protocol. The master controller keeps the line low during this time.

The master device can detect the acknowledge condition with its input by releasing the MODE/DATA pin after t_{valACK} and reading back a 0.

In case of an invalid device address, or not-correctly-received protocol, application of a no-acknowledge condition does not occur; thus, the internal MOSFET does not turn on, and the external pullup resistor pulls the MODE/DATA pin high after t_{valACK} . One can use the MODE/DATA pin again after the acknowledge condition ends.

NOTE

The master device must have an open-drain output in order to request the acknowledge condition.

In case of a push-pull output stage, TI recommends using a series resistor in the MODE/DATA line to limit the current to 500 μ A in case of an accidentally requested acknowledge, to protect the internal ACKN-MOSFET.

8.5.1.3 Mode Selection

Use of the MODE/DATA pin for two functions, interface and mode selection, necessitates a determination of when to decode the bit stream or to change the operation mode.

The device enters forced PWM mode operation immediately whenever the MODE/DATA pin turns to high level. The device also stays in forced PWM mode during the entire protocol reception time.

With a falling edge on the MODE/DATA pin, the device starts bit decoding. If the MODE/DATA pin stays low for at least $t_{timeout}$, the device gets an internal time-out and enables power-save-mode operation.

The device ignores a protocol sent within this time because the first interpretation of a falling edge for the mode change is at the start of the first bit. In this case, TI recommends sending the protocol first, and then changing to power-save mode at the end of the protocol.

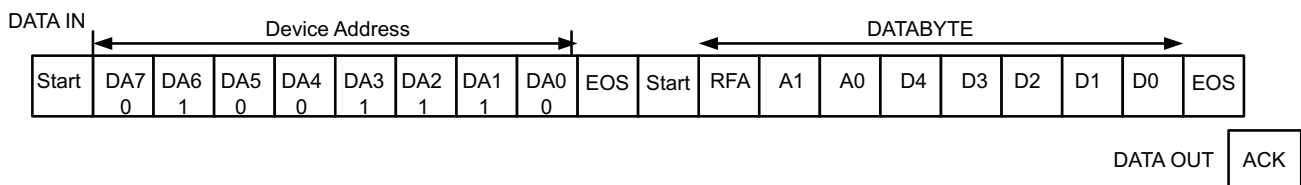
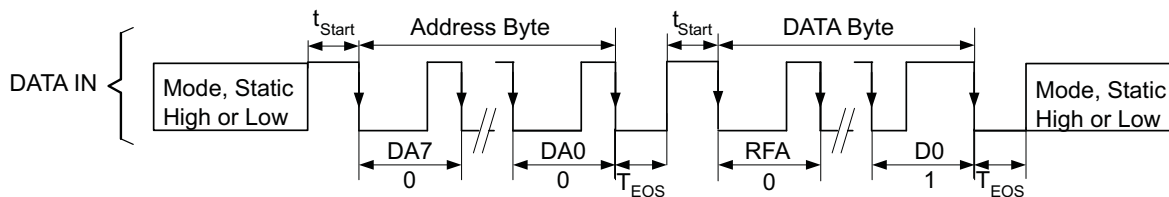
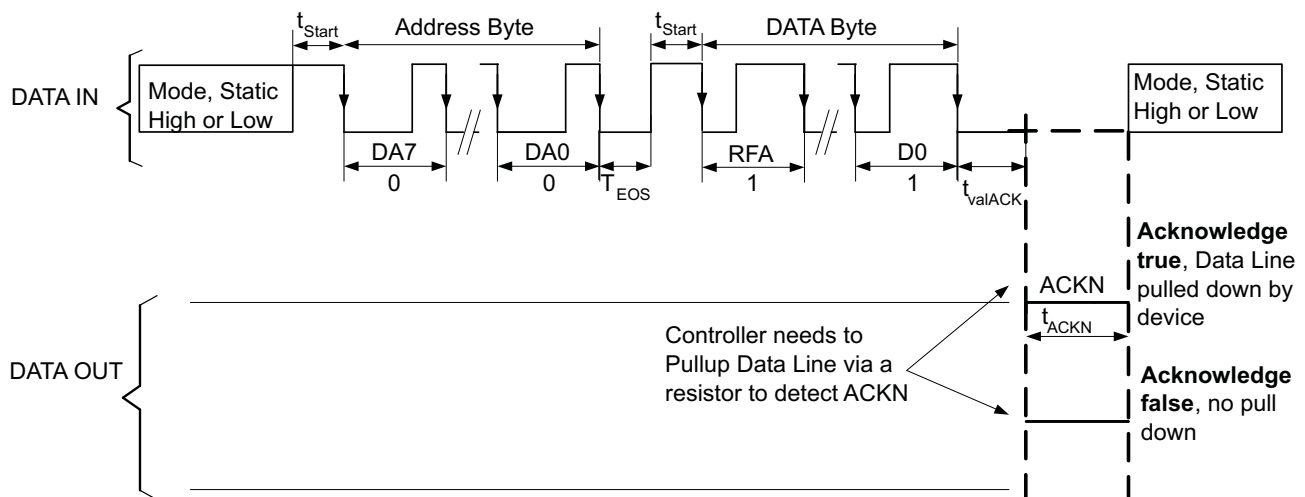

Figure 8. EasyScale Protocol Overview

Table 2. EasyScale Bit Description

BYTE	BIT NUMBER	NAME	TRANSMISSION DIRECTION	DESCRIPTION
Device address byte 4E hex	7	DA7	IN	0 MSB device address
	6	DA6	IN	1
	5	DA5	IN	0
	4	DA4	IN	0
	3	DA3	IN	1
	2	DA2	IN	1
	1	DA1	IN	1
	0	DA0	IN	0 LSB device address
Data byte	7 (MSB)	RFA	IN	Request for acknowledge; if high, the device applies an acknowledge condition.
	6	A1		Address bit 1
	5	A0		Address bit 0
	4	D4		Data bit 4
	3	D3		Data bit 3
	2	D2		Data bit 2
	1	D1		Data bit 1
	0 (LSB)	D0		Data bit 0
		ACK	OUT	Acknowledge condition active 0, the device applies this condition only in the case of a set RFA bit. Open-drain output, the host must pull the line high with a pullup resistor. One can only use this feature if the master has an open-drain output stage. In case of a push-pull output stage, do not request an acknowledge condition.

Figure 9. EasyScale Protocol Without Acknowledge

Figure 10. EasyScale Protocol Including Acknowledge

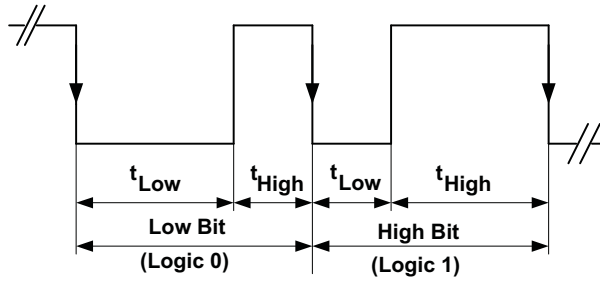

Figure 11. EasyScale – Bit Coding

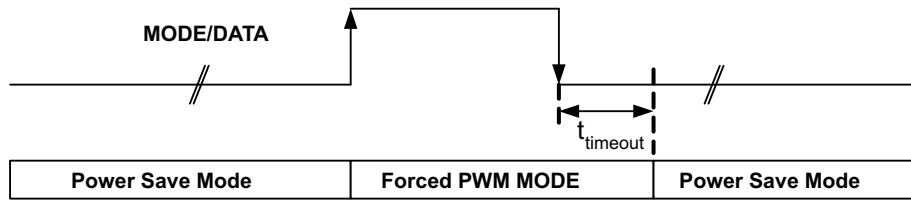

Figure 12. MODE/DATA PIN: Mode Selection

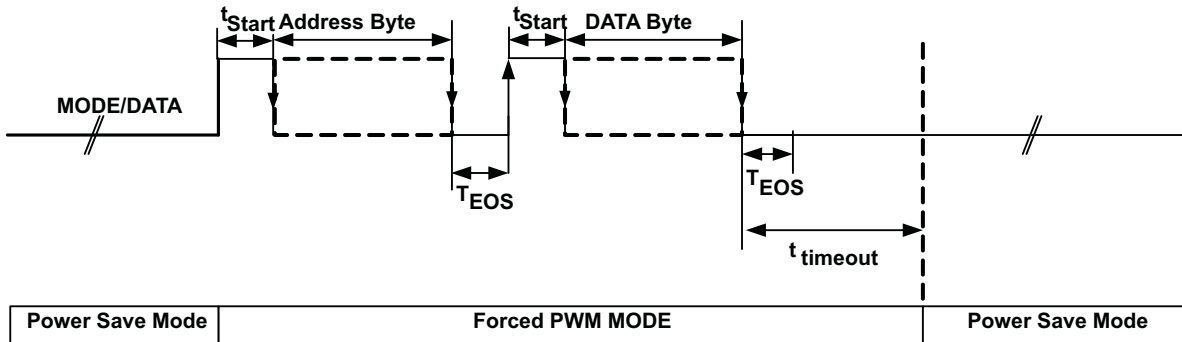

Figure 13. MODE/DATA Pin: Power-Save-Mode and Interface Communication

**Table 3. Selectable Output Voltages for Converter 1,
With Pin DEF_1 as Digital Input**

	TPS624xx-Q1 OUTPUT VOLTAGE [V] REGISTER REG_DEF_1_LOW	TPS624xx-Q1 VOLTAGE [V] REGISTER REG_DEF_1_HIGH	D4	D3	D2	D1	D0
0	0.8	0.9	0	0	0	0	0
1	0.825	0.925	0	0	0	0	1
2	0.85	0.95	0	0	0	1	0
3	0.875	0.975	0	0	0	1	1
4	0.9	1.0	0	0	1	0	0
5	0.925	1.025	0	0	1	0	1
6	0.95	1.050	0	0	1	1	0
7	0.975	1.075	0	0	1	1	1
8	1.0	1.1	0	1	0	0	0
9	1.025	1.125	0	1	0	0	1
10	1.050	1.150	0	1	0	1	0
11	1.075	1.175	0	1	0	1	1
12	1.1	1.2	0	1	1	0	0
13	1.125	1.225	0	1	1	0	1
14	1.150	1.25	0	1	1	1	0
15	1.175	1.275	0	1	1	1	1
16	1.2	1.3	1	0	0	0	0
17	1.225	1.325	1	0	0	0	1
18	1.25	1.350	1	0	0	1	0
19	1.275	1.375	1	0	0	1	1
20	1.3	1.4	1	0	1	0	0
21	1.325	1.425	1	0	1	0	1
22	1.350	1.450	1	0	1	1	0
23	1.375	1.475	1	0	1	1	1
24	1.4	1.5	1	1	0	0	0
25	1.425	1.525	1	1	0	0	1
26	1.450	1.55	1	1	0	1	0
27	1.475	1.575	1	1	0	1	1
28	1.5	1.6	1	1	1	0	0
29	1.525	1.7	1	1	1	0	1
30	1.55	1.8	1	1	1	1	0
31	1.575	1.9	1	1	1	1	1

**Table 4. Selectable Output Voltages for Converter 2,
(ADJ2 Connected to V_{OUT2})**

	OUTPUT VOLTAGE [V] FOR REGISTER REG_DEF_2	D4	D3	D2	D1	D0
0	0.6	0	0	0	0	0
1	0.85	0	0	0	0	1
2	0.9	0	0	0	1	0
3	0.95	0	0	0	1	1
4	1	0	0	1	0	0
5	1.05	0	0	1	0	1
6	1.1	0	0	1	1	0
7	1.15	0	0	1	1	1
8	1.2	0	1	0	0	0
9	1.25	0	1	0	0	1
10	1.3	0	1	0	1	0
11	1.35	0	1	0	1	1
12	1.4	0	1	1	0	0
13	1.45	0	1	1	0	1
14	1.5	0	1	1	1	0
15	1.55	0	1	1	1	1
16	1.6	1	0	0	0	0
17	1.7	1	0	0	0	1
18	1.8	1	0	0	1	0
19	1.85	1	0	0	1	1
20	2	1	0	1	0	0
21	2.1	1	0	1	0	1
22	2.2	1	0	1	1	0
23	2.3	1	0	1	1	1
24	2.4	1	1	0	0	0
25	2.5	1	1	0	0	1
26	2.6	1	1	0	1	0
27	2.7	1	1	0	1	1
28	2.8	1	1	1	0	0
29	2.85	1	1	1	0	1
30	3	1	1	1	1	0
31	3.3	1	1	1	1	1

9 Application and Implementation

NOTE

Information in the following application sections is not part of the TI component specification, and TI does not warrant its accuracy or completeness. TI's customers are responsible for determining suitability of components for their purposes. Customers should validate and test their design implementation to confirm system functionality.

9.1 Application Information

9.1.1 Application Information

The TPS624xx-Q1 family of devices are synchronous dual step-down DC-DC converters. The devices provide two independent output voltage rails. The following information provides guidance on selecting external components to complete the application design.

9.2 Typical Application

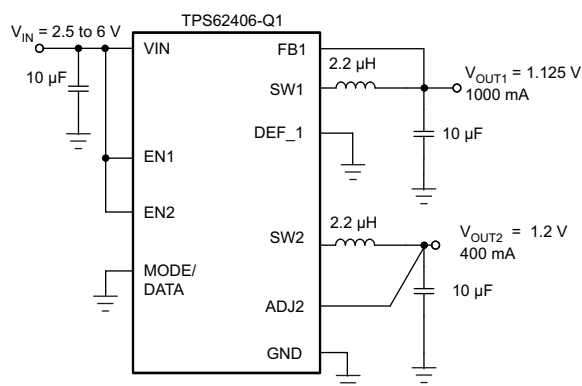

Figure 14. Typical Application Schematic

9.2.1 Design Requirements

The step-down converter design can be adapted to different output voltage and load current needs. The following design procedure is adequate for whole V_{IN} , V_{OUTx} and load current range of the TPS624xx-Q1 family of devices.

9.2.2 Detailed Design Procedure

9.2.2.1 Output Voltage Setting

9.2.2.1.1 Converter 1 Fixed Default Output-Voltage Setting

The DEF_1 pin selects output voltage V_{OUT1} .

Pin DEF_1 = low:

- TPS62406-Q1, TPS62407-Q1 = 1.125 V
- TPS62422-Q1 = 1.15V
- TPS62423-Q1 = 1.2V
- TPS62424-Q1 = 1.1V

Pin DEF_1 = high:

- TPS62406-Q1 = 1.125 V
- TPS62407-Q1 = 1.225 V
- TPS62422-Q1 = 1.8V
- TPS62423-Q1 = 1.5V
- TPS62424-Q1 = 1.3V

Typical Application (continued)

9.2.2.1.2 Converter 2 Fixed Default Output-Voltage Setting

ADJ2 pin must be directly connected with V_{OUT2} :

- TPS62406-Q1, V_{OUT2} default = 1.2 V
- TPS62407-Q1, V_{OUT2} default = 1.85 V
- TPS62422-Q1, V_{OUT2} default = 1.2 V
- TPS62423-Q1, V_{OUT2} default = 1.8 V
- TPS62424-Q1, V_{OUT2} default = 1.8 V

9.2.2.2 Output Filter Design (Inductor and Output Capacitor)

The converters operate with a minimum inductance of 1.75 μH and minimum capacitance of 6 μF . The device operation is optimum with inductors of 2.2 μH to 4.7 μH and output capacitors of 10 μF to 22 μF .

9.2.2.2.1 Inductor Selection

Select the inductor based on its ratings for dc resistance and saturation current. The dc resistance of the inductor directly influences the efficiency of the converter. Therefore, select an inductor with lowest dc resistance for highest efficiency.

Equation 4 calculates the maximum inductor current under static load conditions. The saturation-current rating of the inductor should be higher than the maximum inductor current as calculated with Equation 5. TI makes this recommendation because during heavy load transients the inductor current rises above the calculated value.

$$\Delta I_L = V_{out} \times \frac{1 - \frac{V_{out}}{V_{in}}}{L \times f}$$

where

- ΔI_L = Peak-to-peak inductor ripple current
- L = Inductor value
- f = Switching frequency (2.25 MHz typical)

(4)

$$I_{Lmax} = I_{outmax} + \frac{\Delta I_L}{2}$$

where

- I_{Lmax} = Maximum inductor current

and the highest inductor current occurs at maximum V_{IN} .

(5)

Open-core inductors have a soft saturation characteristic and they can usually handle higher inductor currents versus a comparable shielded inductor.

A more conservative approach is to select the inductor current rating just for the maximum switch current of the corresponding converter. Take into consideration that the core material from inductor to inductor differs, and this difference has an impact on the efficiency.

See Table 5 and the typical application circuit examples for possible inductors.

Table 5. List of Inductors

DIMENSIONS [mm]	INDUCTOR TYPE	SUPPLIER
3.2 x 2.6 x 1	MIPW3226	FDK
3 x 3 x 0.9	LPS3010	Coilcraft
2.8 x 2.6 x 1	VLF3010	TDK
2.8 x 2.6 x 1.4	VLF3014	TDK
3 x 3 x 1.4	LPS3015	Coilcraft
3.9 x 3.9 x 1.7	LPS4018	Coilcraft

9.2.2.2.2 Output-Capacitor Selection

The advanced fast-response voltage-mode control scheme of the converters allows the use of tiny ceramic capacitors with a typical value of 10 μF to 22 μF , without having large output-voltage under- and overshoots during heavy load transients. Ceramic capacitors with low ESR values result in lowest output-voltage ripple, and TI therefore recommends them. The output capacitor requires either X7R or X5R dielectric. TI does not recommend Y5V and Z5U dielectric capacitors because of their wide variation in capacitance.

If using ceramic output capacitors, the capacitor rms ripple-current rating always meets the application requirements. The rms ripple current calculation is:

$$I_{\text{RMS}C_{\text{out}}} = V_{\text{out}} \times \frac{1 - \frac{V_{\text{out}}}{V_{\text{in}}}}{L \times f} \times \frac{1}{2 \times \sqrt{3}} \quad (6)$$

At nominal load current, the inductive converters operate in PWM mode and the overall output voltage ripple is the sum of the voltage spike caused by the output capacitor ESR, plus the voltage ripple caused by charging and discharging the output capacitor:

$$\Delta V_{\text{out}} = V_{\text{out}} \times \frac{1 - \frac{V_{\text{out}}}{V_{\text{in}}}}{L \times f} \times \left(\frac{1}{8 \times C_{\text{out}} \times f} + \text{ESR} \right) \quad (7)$$

where the highest output-voltage ripple occurs at the highest input voltage, V_{IN} .

At light load currents, the converters operate in power-save mode and the output-voltage ripple depends on the output-capacitor value. The internal comparator delay and the external capacitor set the output-voltage ripple. Higher output capacitors like 22 μF values minimize the voltage ripple in PFM mode and tighten dc output accuracy in PFM mode.

9.2.2.2.3 Input Capacitor Selection

Because of the nature of the buck converter having a pulsating input current, the device requires a low-ESR input capacitor to prevent large voltage transients that can cause misbehavior of the device or interference with other circuits in the system. An input capacitor of 10 μF is sufficient.

9.2.3 Application Curves

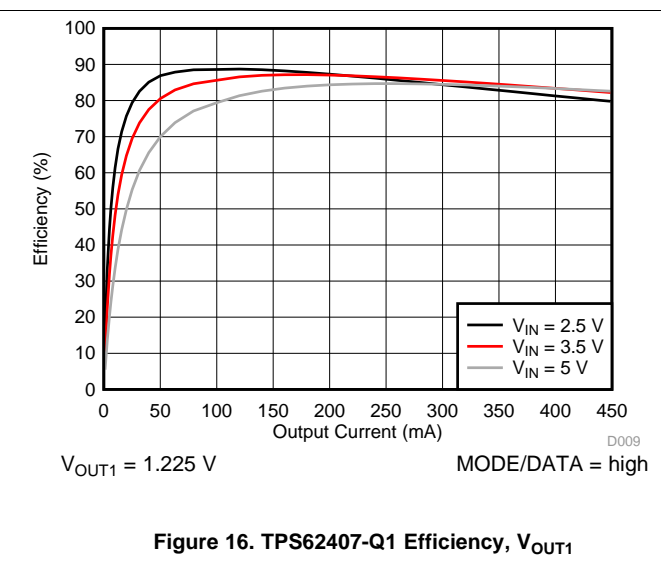
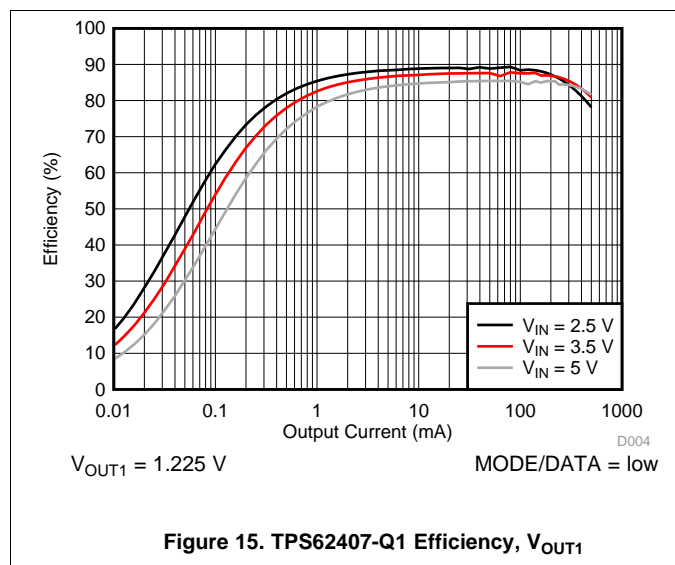

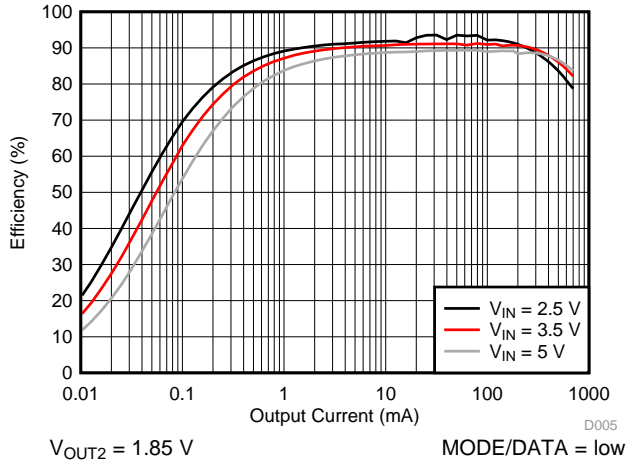

Figure 17. TPS62407-Q1 Efficiency, V_{OUT2}

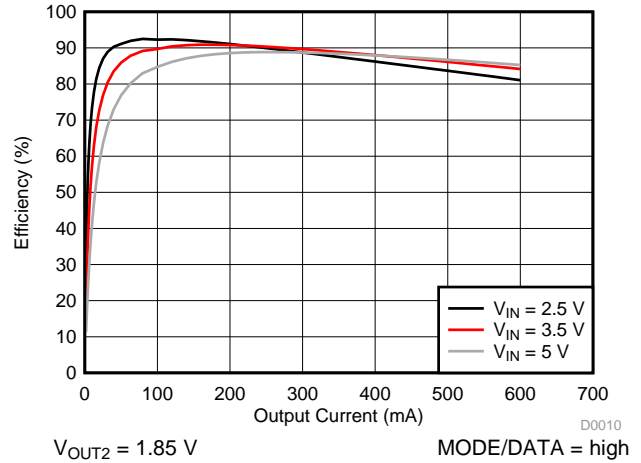

Figure 18. TPS62407-Q1 Efficiency, V_{OUT2}

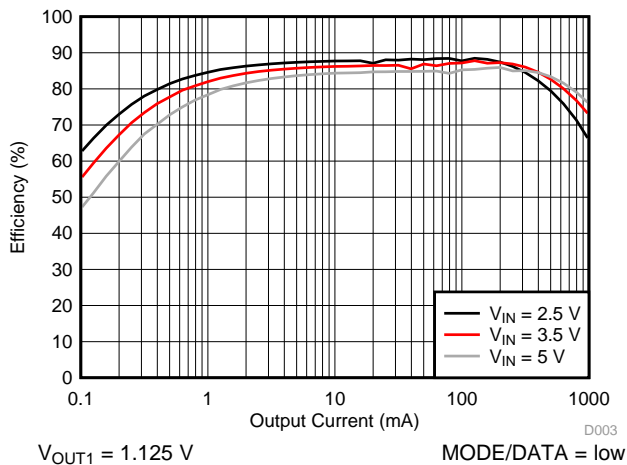

Figure 19. TPS62406-Q1 Efficiency, V_{OUT1}

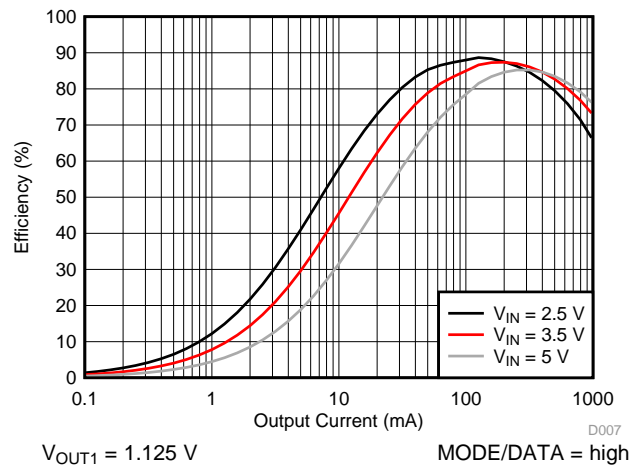

Figure 20. TPS62406-Q1 Efficiency, V_{OUT2}

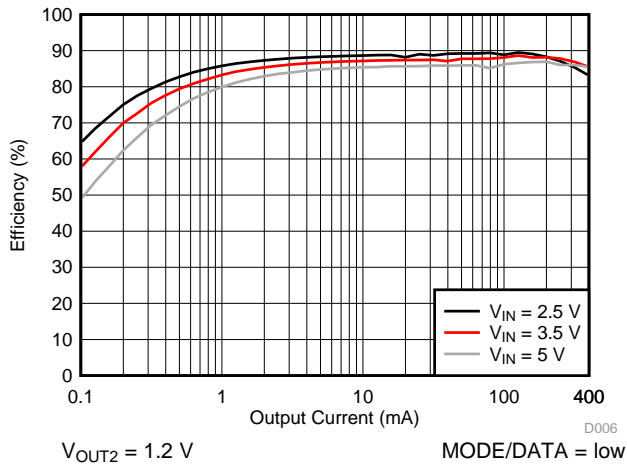

Figure 21. TPS62406-Q1 Efficiency, V_{OUT2}

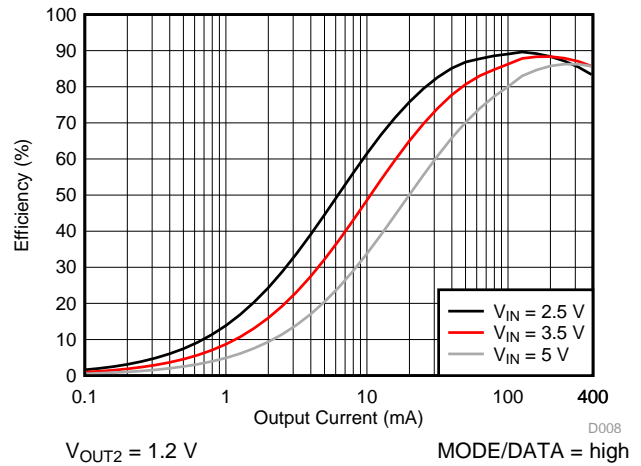

Figure 22. TPS62406-Q1 Efficiency, V_{OUT2}

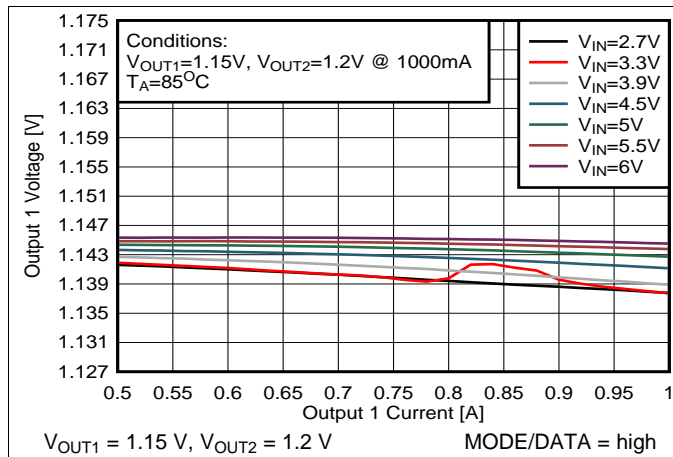

Figure 23. TPS62422-Q1 V_{OUT1} vs. I_{OUT1}

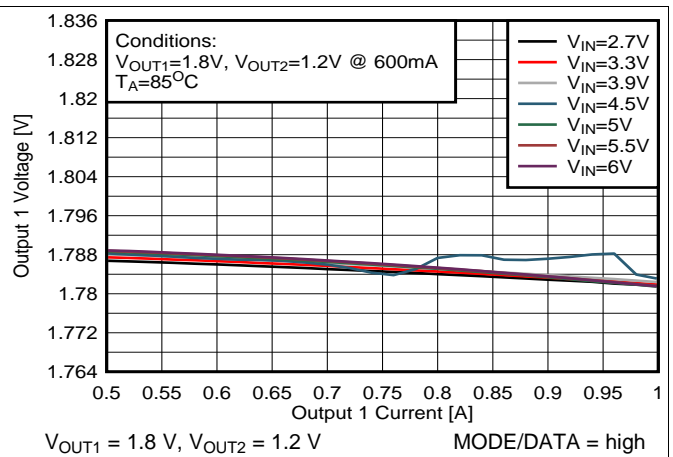

Figure 24. TPS62422-Q1 V_{OUT1} vs. I_{OUT1}

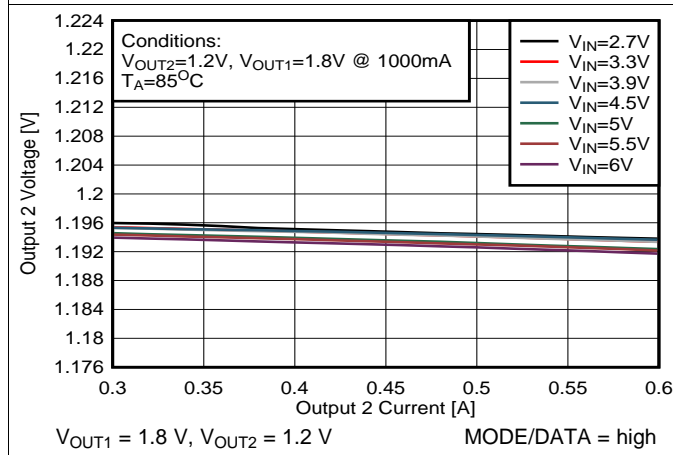

Figure 25. TPS62422-Q1 V_{OUT2} vs. I_{OUT2}

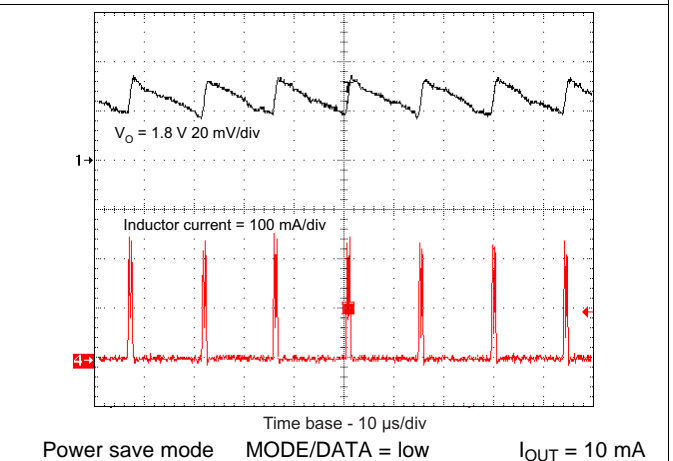

Figure 26. Light-Load Output-Voltage Ripple in Power-Save Mode

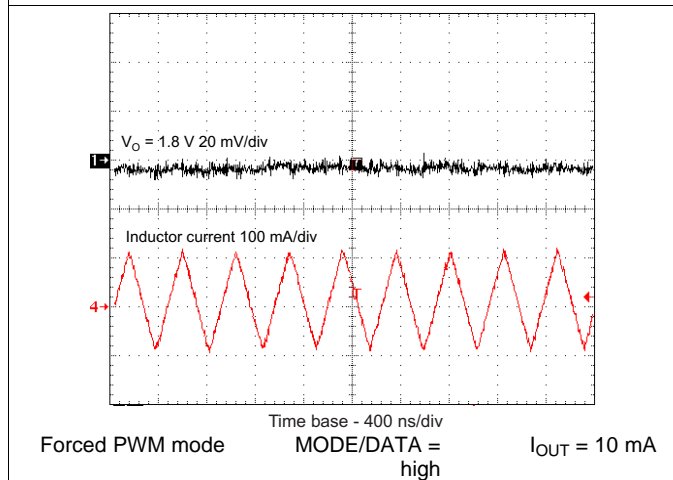

Figure 27. Output-Voltage Ripple in Forced-PWM Mode

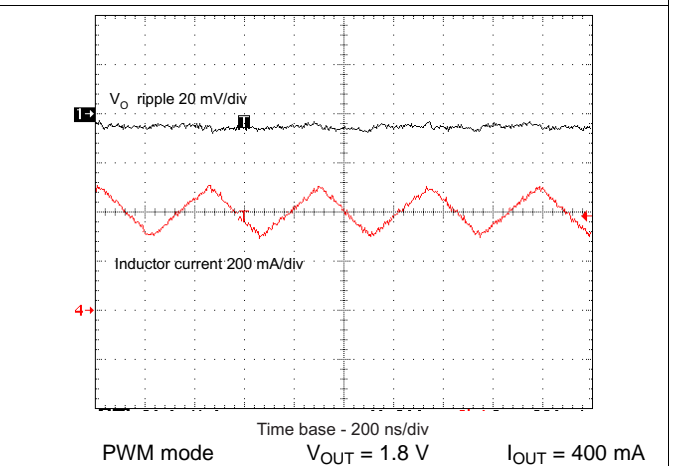

Figure 28. Output-Voltage Ripple in PWM Mode

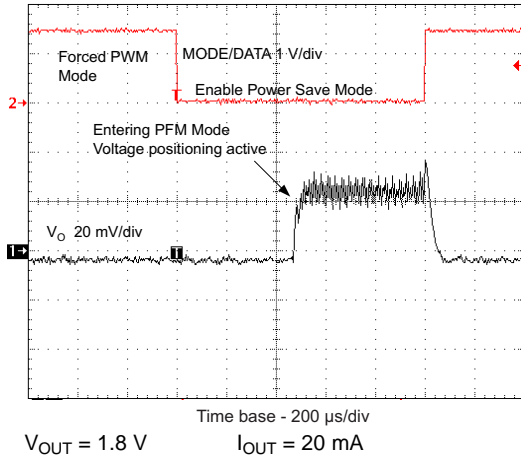

Figure 29. Forced PWM-to-PFM Mode Transition

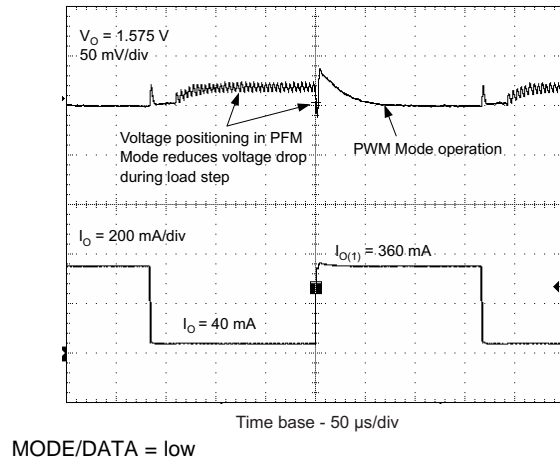

Figure 30. Load-Transient Response, PFM-to-PWM

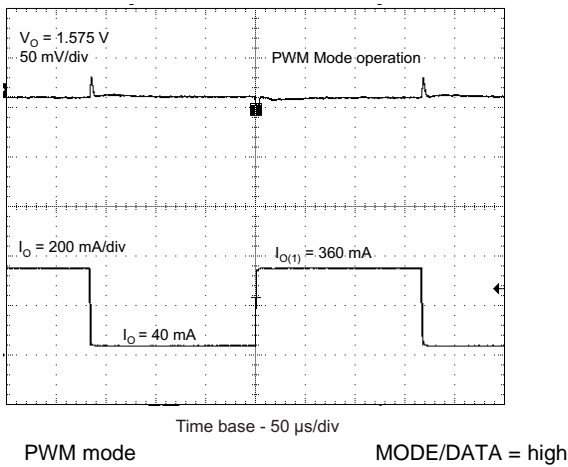

Figure 31. Load-Transient Response, PWM Operation

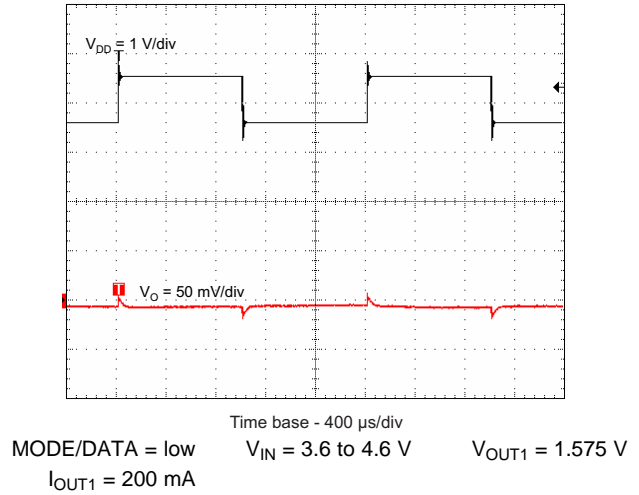

Figure 32. Line-Transient Response

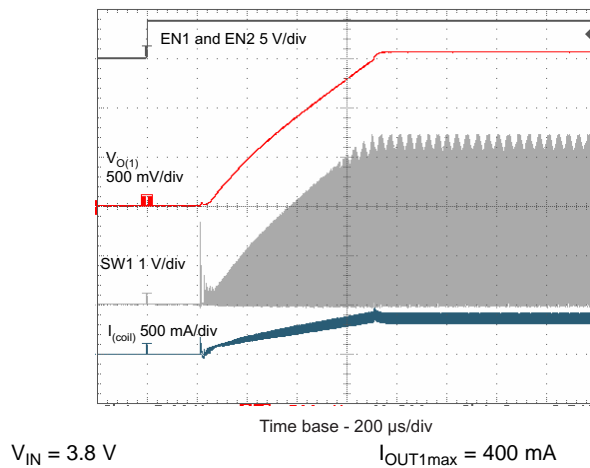

Figure 33. Startup Timing, One Converter

9.3 System Examples

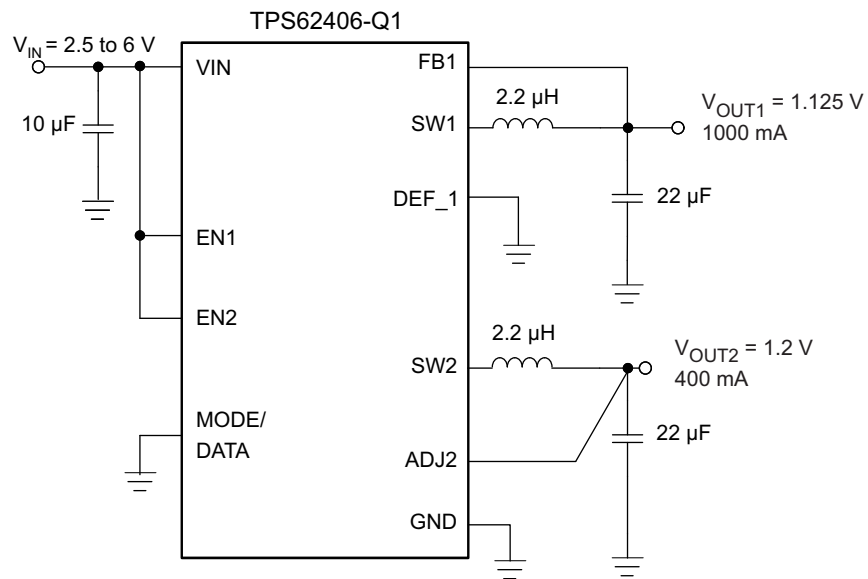

Figure 34. TPS62406-Q1 Fixed 1.125-V and 1.2-V Outputs

System Examples (continued)

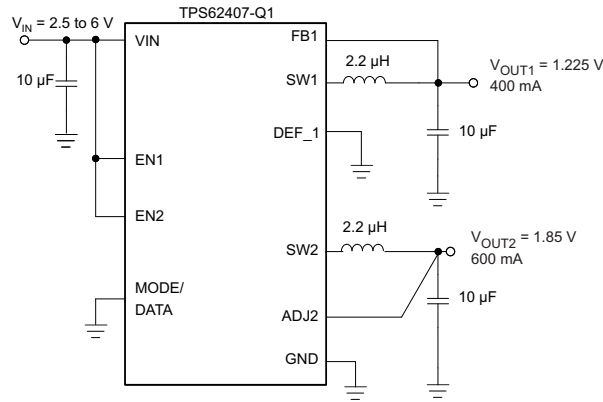

Figure 35. TPS62407-Q1 Fixed 1.225-V and 1.85-V Outputs

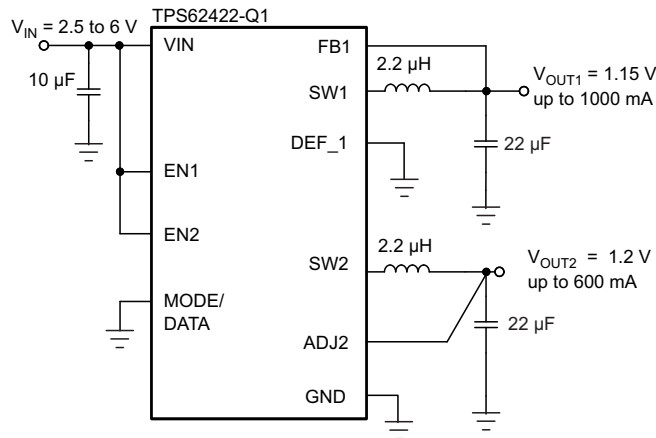

Figure 36. TPS62422-Q1 Fixed 1.15-V and 1.2-V Outputs

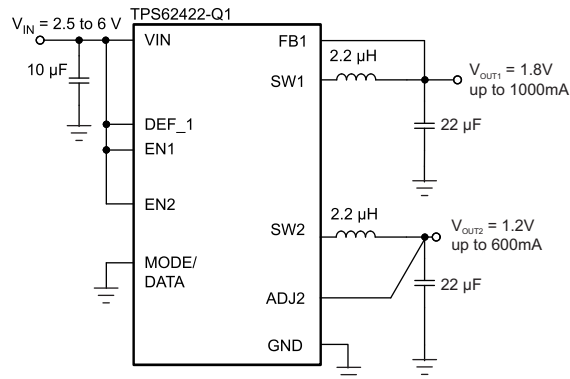

Figure 37. TPS62422-Q1 Fixed 1.8-V and 1.2-V Outputs

10 Power Supply Recommendations

This device has no special recommendation for the power supply. TI recommends to use the values listed in the [Recommended Operating Conditions](#) table.

11 Layout

11.1 Layout Guidelines

- As for all switching power supplies, the layout is an important step in the design. Proper function of the device demands careful attention to PCB layout.
- It is critical to provide a low-inductance, low-impedance ground path. Therefore, use wide and short traces for the main current paths as indicated in bold in [Figure 38](#).
- Place the input capacitor as close as possible to the IC pins VIN and GND, the inductor and output capacitor as close as possible to the pins SW1 and GND.
- Connect the GND pin of the device to the PowerPAD of the PCB and use this pad as a star point. For each converter, use a common power GND node and a different node for the signal GND to minimize the effects of ground noise.
- Connect these ground nodes together to the PowerPAD (star point) underneath the IC. Keep the common path to the GND PIN, which returns the small signal components and the high current of the output capacitors, as short as possible to avoid ground noise.
- Connect the output voltage-sense lines (FB 1, DEF_1, ADJ2) right to the output capacitor and route them away from noisy components and traces (for example, the SW1 and SW2 lines).
- If operating the EasyScale interface with high transmission rates, route the MODE/DATA trace away from the ADJ2 line to avoid capacitive coupling into the ADJ2 pin.
- A GND guard ring between the MODE/DATA pin and ADJ2 pin avoids potential noise coupling.

11.2 Layout Example

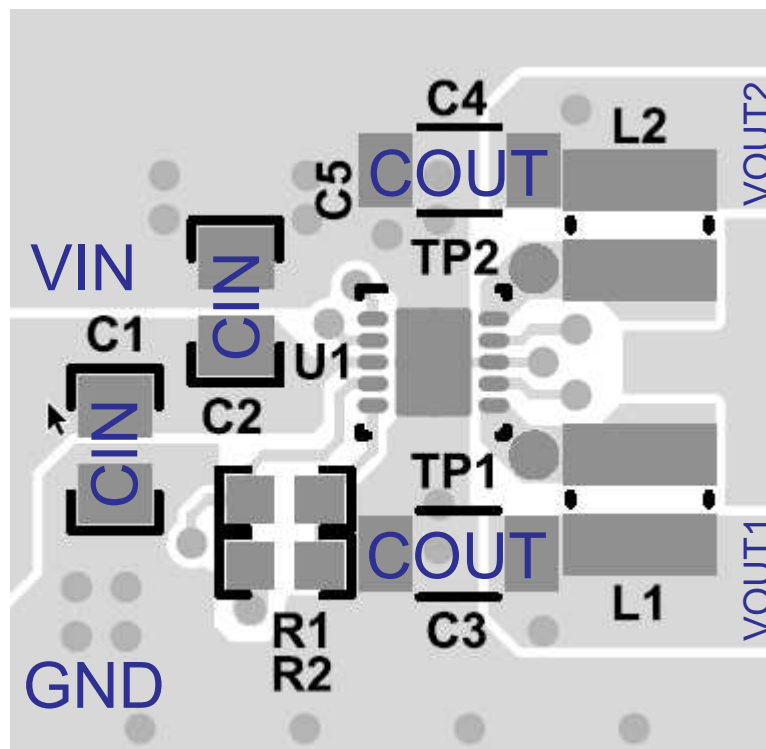

Figure 38. Layout Diagram

12 器件和文档支持

12.1 相关链接

下表列出了快速访问链接。类别包括技术文档、支持和社区资源、工具和软件，以及立即订购快速访问。

表 6. 相关链接

器件	产品文件夹	立即订购	技术文档	工具与软件	支持和社区
TPS62406-Q1	单击此处	单击此处	单击此处	单击此处	单击此处
TPS62407-Q1	单击此处	单击此处	单击此处	单击此处	单击此处
TPS62422-Q1	单击此处	单击此处	单击此处	单击此处	单击此处
TPS62423-Q1	单击此处	单击此处	单击此处	单击此处	单击此处
TPS62424-Q1	单击此处	单击此处	单击此处	单击此处	单击此处

12.2 社区资源

下列链接提供到 TI 社区资源的连接。链接的内容由各个分销商“按照原样”提供。这些内容并不构成 TI 技术规范，并且不一定反映 TI 的观点；请参阅 TI 的《使用条款》。

TI E2E™ 在线社区 *TI 的工程师对工程师 (E2E) 社区*。此社区的创建目的在于促进工程师之间的协作。在 e2e.ti.com 中，您可以咨询问题、分享知识、拓展思路并与同行工程师一道帮助解决问题。

设计支持 *TI 参考设计支持* 可帮助您快速查找有帮助的 E2E 论坛、设计支持工具以及技术支持的联系信息。

12.3 商标

EasyScale, the EasyScale, E2E are trademarks of Texas Instruments.
All other trademarks are the property of their respective owners.

12.4 静电放电警告



这些装置包含有限的内置 ESD 保护。存储或装卸时，应将导线一起截短或将装置放置于导电泡棉中，以防止 MOS 门极遭受静电损伤。

12.5 术语表

SLYZ022 — *TI 术语表*。

这份术语表列出并解释术语、缩写和定义。

13 机械、封装和可订购信息

以下页面包含机械、封装和可订购信息。这些信息是指定器件的最新可用数据。数据如有变更，恕不另行通知，且不会对此文档进行修订。如需获取此产品说明书的浏览器版本，请查阅左侧的导航栏。

13.1 Package Option Addendum

13.1.1 Packaging Information

Orderable Device	Status ⁽¹⁾	Package Type	Package Drawing	Pins	Package Qty	Eco Plan ⁽²⁾	Lead/Ball Finish	MSL Peak Temp ⁽³⁾	Op Temp (°C)	Device Marking ⁽⁴⁾⁽⁵⁾
TPS62406QDRCRQ1	PREVIEW	VSON	DRC	10	3000	Green (RoHS & no Sb/Br)	CU NIPDAU	Level-3-260C-168 HR	-40 to 125	2406Q
TPS62407QDRCRQ1	PREVIEW	VSON	DRC	10	3000	Green (RoHS & no Sb/Br)	CU NIPDAU	Level-3-260C-168 HR	-40 to 125	SHU
TPS62422QDRCRQ1	PREVIEW	VSON	DRC	10	3000	Green (RoHS & no Sb/Br)	CU NIPDAU	Level-3-260C-168 HR	-40 to 125	
TPS62423QDRCRQ1	PREVIEW	VSON	DRC	10	3000	Green (RoHS & no Sb/Br)	CU NIPDAU	Level-3-260C-168 HR	-40 to 125	
TPS62424QDRCRQ1	PREVIEW	VSON	DRC	10	3000	Green (RoHS & no Sb/Br)	CU NIPDAU	Level-3-260C-168 HR	-40 to 125	

- (1) The marketing status values are defined as follows:
ACTIVE: Product device recommended for new designs.
LIFEBUY: TI has announced that the device will be discontinued, and a lifetime-buy period is in effect.
NRND: Not recommended for new designs. Device is in production to support existing customers, but TI does not recommend using this part in a new design.
PRE_PROD Unannounced device, not in production, not available for mass market, nor on the web, samples not available.
PREVIEW: Device has been announced but is not in production. Samples may or may not be available.
OBSOLETE: TI has discontinued the production of the device.
- (2) Eco Plan - The planned eco-friendly classification: Pb-Free (RoHS), Pb-Free (RoHS Exempt), or Green (RoHS & no Sb/Br) - please check <http://www.ti.com/productcontent> for the latest availability information and additional product content details.
TBD: The Pb-Free/Green conversion plan has not been defined.
Pb-Free (RoHS): TI's terms "Lead-Free" or "Pb-Free" mean semiconductor products that are compatible with the current RoHS requirements for all 6 substances, including the requirement that lead not exceed 0.1% by weight in homogeneous materials. Where designed to be soldered at high temperatures, TI Pb-Free products are suitable for use in specified lead-free processes.
Pb-Free (RoHS Exempt): This component has a RoHS exemption for either 1) lead-based flip-chip solder bumps used between the die and package, or 2) lead-based die adhesive used between the die and leadframe. The component is otherwise considered Pb-Free (RoHS compatible) as defined above.
Green (RoHS & no Sb/Br): TI defines "Green" to mean Pb-Free (RoHS compatible), and free of Bromine (Br) and Antimony (Sb) based flame retardants (Br or Sb do not exceed 0.1% by weight in homogeneous material)
- (3) MSL, Peak Temp. -- The Moisture Sensitivity Level rating according to the JEDEC industry standard classifications, and peak solder temperature.
- (4) There may be additional marking, which relates to the logo, the lot trace code information, or the environmental category on the device
- (5) Multiple Device markings will be inside parentheses. Only on Device Marking contained in parentheses and separated by a "-" will appear on a device. If a line is indented then it is a continuation of the previous line and the two combined represent the entire Device Marking for that device.

Important Information and Disclaimer: The information provided on this page represents TI's knowledge and belief as of the date that it is provided. TI bases its knowledge and belief on information provided by third parties, and makes no representation or warranty as to the accuracy of such information. Efforts are underway to better integrate information from third parties. TI has taken and continues to take reasonable steps to provide representative and accurate information but may not have conducted destructive testing or chemical analysis on incoming materials and chemicals. TI and TI suppliers consider certain information to be proprietary, and thus CAS numbers and other limited information may not be available for release.

In no event shall TI's liability arising out of such information exceed the total purchase price of the TI part(s) at issue in this document sold by TI to Customer on an annual basis.

13.1.2 Tape and Reel Information

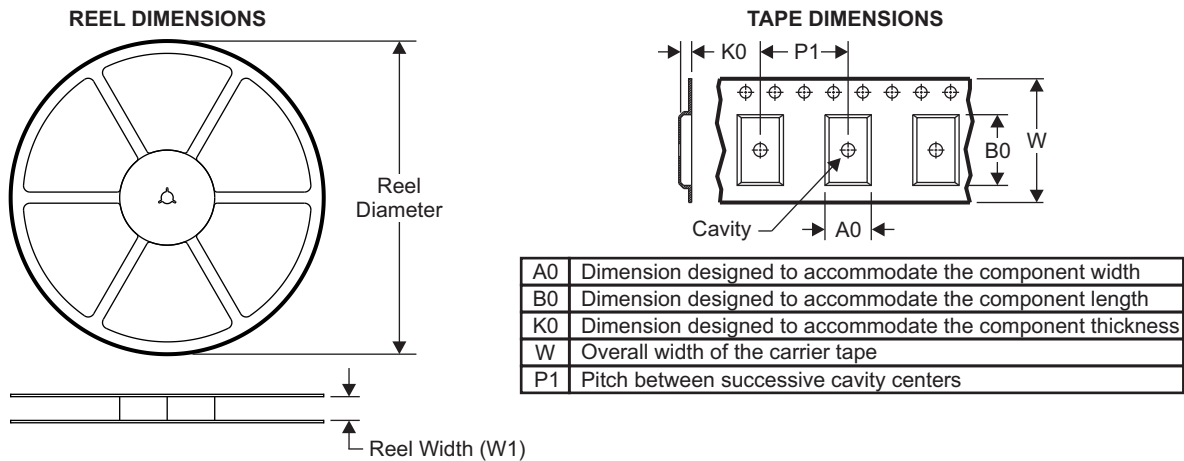

QUADRANT ASSIGNMENTS FOR PIN 1 ORIENTATION IN TAPE

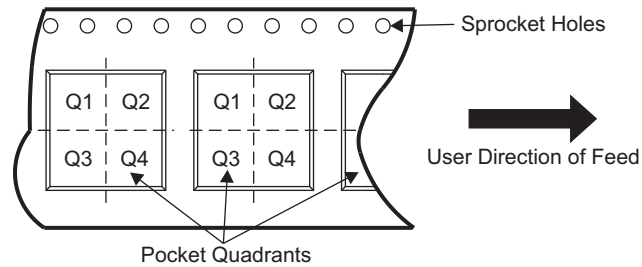

Device	Package Type	Package Drawing	Pins	SPQ	Reel Diameter (mm)	Reel Width W1 (mm)	A0 (mm)	B0 (mm)	K0 (mm)	P1 (mm)	W (mm)	Pin1 Quadrant
TPS62406QDRCRQ1	VSON	DRC	10	3000	330.0	12.4	3.3	3.3	1.1	8.0	12.0	W2
TPS62407QDRCRQ1	VSON	DRC	10	3000	330.0	12.4	3.3	3.3	1.1	8.0	12.0	W2
TPS62422QDRCRQ1	VSON	DRC	10	3000	330.0	12.4	3.3	3.3	1.1	8.0	12.0	W2
TPS62423QDRCRQ1	VSON	DRC	10	3000	330.0	12.4	3.3	3.3	1.1	8.0	12.0	W2
TPS62424QDRCRQ1	VSON	DRC	10	3000	330.0	12.4	3.3	3.3	1.1	8.0	12.0	W2

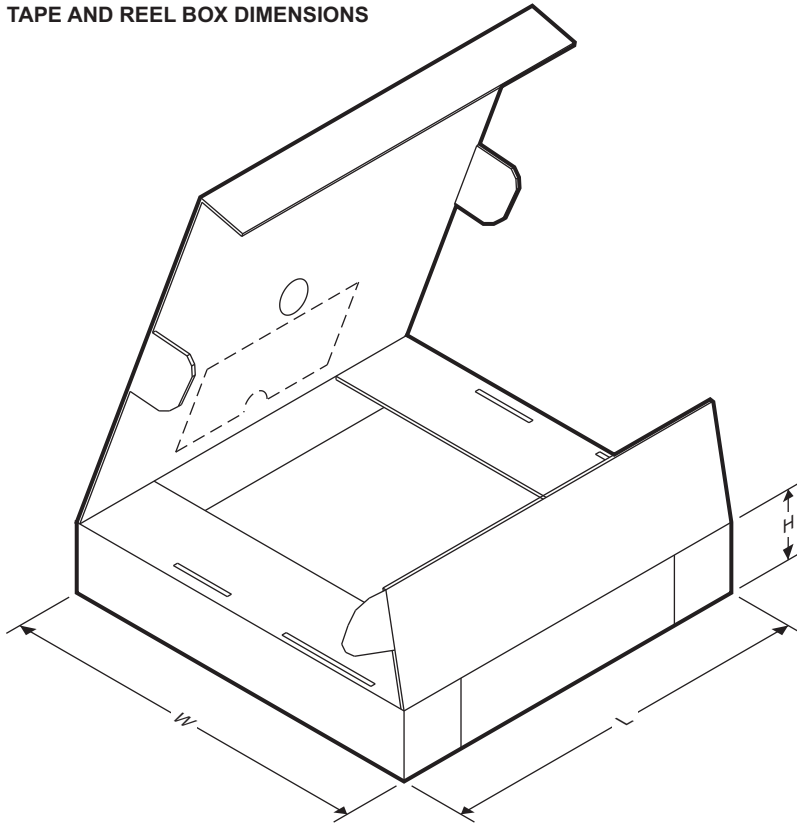
TAPE AND REEL BOX DIMENSIONS

Device	Package Type	Package Drawing	Pins	SPQ	Length (mm)	Width (mm)	Height (mm)
TPS62406QDRCRQ1	VSON	DRC	10	3000	367.0	367.0	35.0
TPS62407QDRCRQ1	VSON	DRC	10	3000	367.0	367.0	35.0
TPS62422QDRCRQ1	VSON	DRC	10	3000	367.0	367.0	35.0
TPS62423QDRCRQ1	VSON	DRC	10	3000	367.0	367.0	35.0
TPS62424QDRCRQ1	VSON	DRC	10	3000	367.0	367.0	35.0

13.2 Mechanical Data

DRC (S-PVSON-N10)

PLASTIC SMALL OUTLINE NO-LEAD

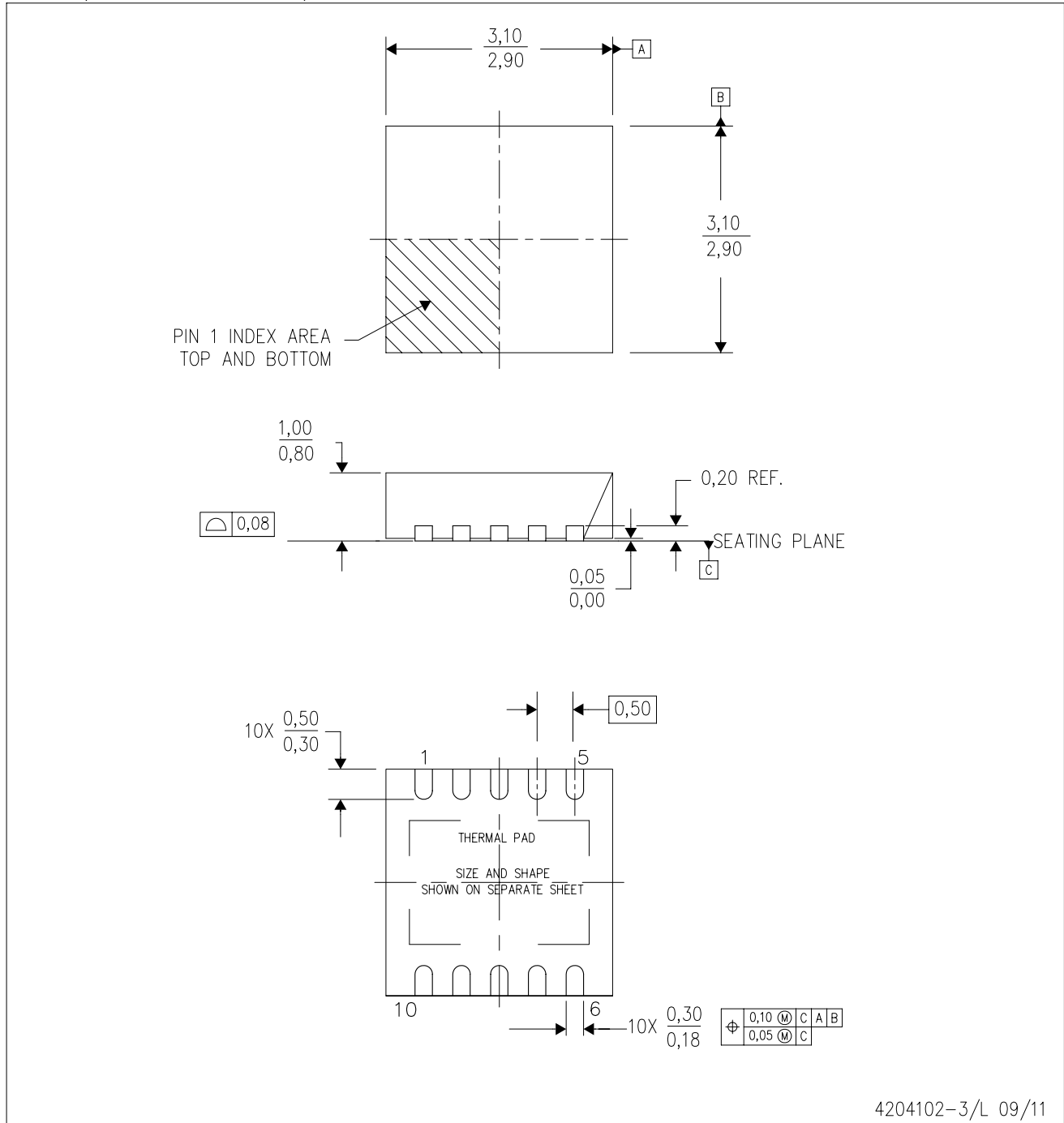

- NOTES:
- All linear dimensions are in millimeters. Dimensioning and tolerancing per ASME Y14.5M-1994.
 - This drawing is subject to change without notice.
 - Small Outline No-Lead (SON) package configuration.
 - The package thermal pad must be soldered to the board for thermal and mechanical performance, if present.
 - See the additional figure in the Product Data Sheet for details regarding the exposed thermal pad features and dimensions, if present

13.2.1 Thermal Pad Mechanical Data

DRC (S-PVSON-N10)

PLASTIC SMALL OUTLINE NO-LEAD

THERMAL INFORMATION

This package incorporates an exposed thermal pad that is designed to be attached directly to an external heatsink. The thermal pad must be soldered directly to the printed circuit board (PCB). After soldering, the PCB can be used as a heatsink. In addition, through the use of thermal vias, the thermal pad can be attached directly to the appropriate copper plane shown in the electrical schematic for the device, or alternatively, can be attached to a special heatsink structure designed into the PCB. This design optimizes the heat transfer from the integrated circuit (IC).

For information on the Quad Flatpack No-Lead (QFN) package and its advantages, refer to Application Report, QFN/SON PCB Attachment, Texas Instruments Literature No. SLUA271. This document is available at www.ti.com.

The exposed thermal pad dimensions for this package are shown in the following illustration.

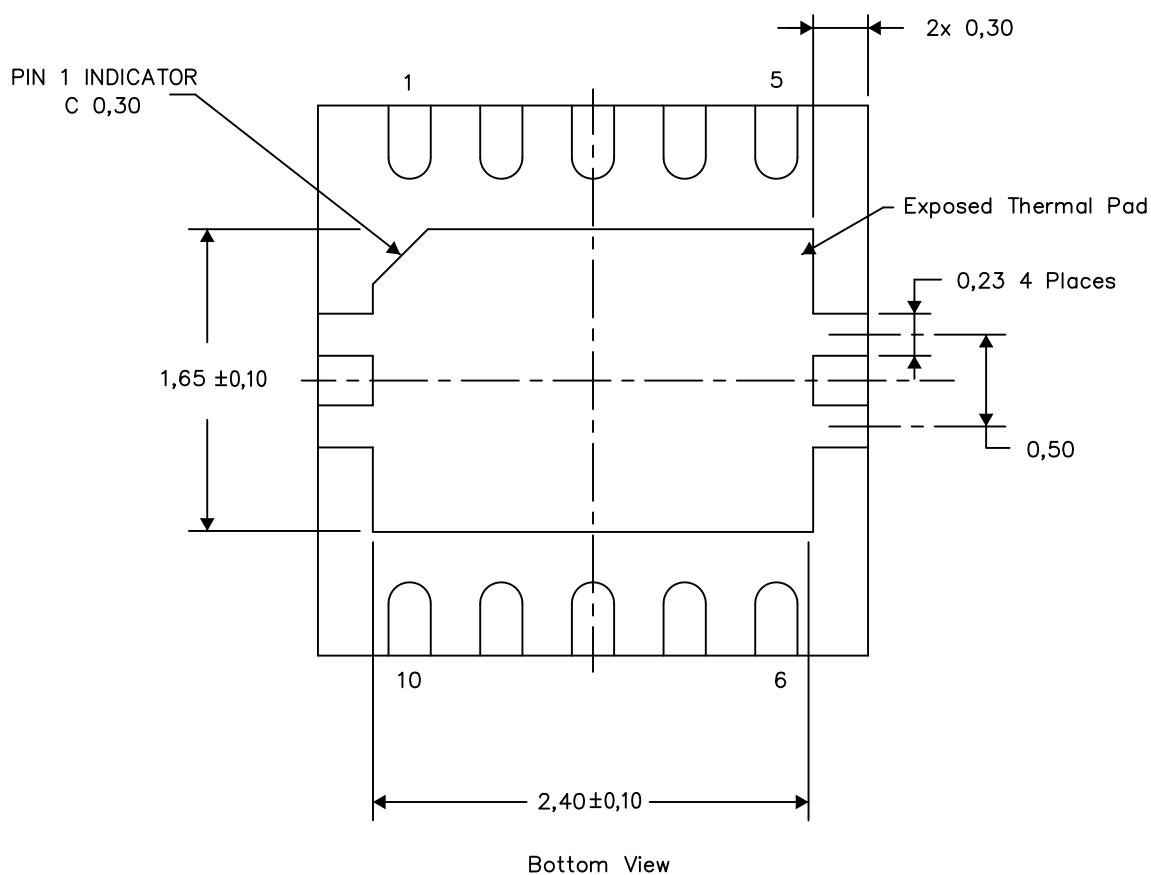

Exposed Thermal Pad Dimensions

4206565-3/Y 08/15

NOTE: A. All linear dimensions are in millimeters

重要声明和免责声明

TI 均以“原样”提供技术性数据（包括数据表）、设计资源（包括参考设计）、应用或其他设计建议、网络工具、安全信息和其他资源，不保证其中不含任何瑕疵，且不做任何明示或暗示的担保，包括但不限于对适销性、适合某特定用途或不侵犯任何第三方知识产权的暗示担保。

所述资源可供专业开发人员应用TI 产品进行设计使用。您将对以下行为独自承担全部责任：(1) 针对您的应用选择合适的TI 产品；(2) 设计、验证并测试您的应用；(3) 确保您的应用满足相应标准以及任何其他安全、安保或其他要求。所述资源如有变更，恕不另行通知。TI 对您使用所述资源的授权仅限于开发资源所涉及TI 产品的相关应用。除此之外不得复制或展示所述资源，也不提供其它TI 或任何第三方的知识产权授权许可。如因使用所述资源而产生任何索赔、赔偿、成本、损失及债务等，TI 对此概不负责，并且您须赔偿由此对TI 及其代表造成的损害。

TI 所提供产品均受TI 的销售条款 (<http://www.ti.com.cn/zh-cn/legal/termsofsale.html>) 以及ti.com.cn上或随附TI产品提供的其他可适用条款的约束。TI提供所述资源并不扩展或以其他方式更改TI 针对TI 产品所发布的可适用的担保范围或担保免责声明。

邮寄地址：上海市浦东新区世纪大道 1568 号中建大厦 32 楼，邮政编码：200122
Copyright © 2018 德州仪器半导体技术（上海）有限公司

PACKAGING INFORMATION

Orderable Device	Status (1)	Package Type	Package Drawing	Pins	Package Qty	Eco Plan (2)	Lead finish/ Ball material (6)	MSL Peak Temp (3)	Op Temp (°C)	Device Marking (4/5)	Samples
TPS62406QDRCRQ1	ACTIVE	VSON	DRC	10	3000	RoHS & Green	NIPDAU	Level-3-260C-168 HR	-40 to 125	2406Q	Samples
TPS62407QDRCRQ1	ACTIVE	VSON	DRC	10	3000	RoHS & Green	NIPDAU	Level-3-260C-168 HR	-40 to 125	SHU	Samples
TPS62422QDRCRQ1	ACTIVE	VSON	DRC	10	3000	RoHS & Green	NIPDAUAG	Level-3-260C-168 HR	-40 to 125	2422Q	Samples
TPS62423QDRCRQ1	ACTIVE	VSON	DRC	10	3000	RoHS & Green	NIPDAUAG	Level-3-260C-168 HR	-40 to 125	2423Q	Samples
TPS62424QDRCRQ1	ACTIVE	VSON	DRC	10	3000	RoHS & Green	NIPDAUAG	Level-3-260C-168 HR	-40 to 125	2424Q	Samples

(1) The marketing status values are defined as follows:

ACTIVE: Product device recommended for new designs.

LIFEBUY: TI has announced that the device will be discontinued, and a lifetime-buy period is in effect.

NRND: Not recommended for new designs. Device is in production to support existing customers, but TI does not recommend using this part in a new design.

PREVIEW: Device has been announced but is not in production. Samples may or may not be available.

OBSELETE: TI has discontinued the production of the device.

(2) **RoHS:** TI defines "RoHS" to mean semiconductor products that are compliant with the current EU RoHS requirements for all 10 RoHS substances, including the requirement that RoHS substance do not exceed 0.1% by weight in homogeneous materials. Where designed to be soldered at high temperatures, "RoHS" products are suitable for use in specified lead-free processes. TI may reference these types of products as "Pb-Free".

RoHS Exempt: TI defines "RoHS Exempt" to mean products that contain lead but are compliant with EU RoHS pursuant to a specific EU RoHS exemption.

Green: TI defines "Green" to mean the content of Chlorine (Cl) and Bromine (Br) based flame retardants meet JS709B low halogen requirements of <=1000ppm threshold. Antimony trioxide based flame retardants must also meet the <=1000ppm threshold requirement.

(3) MSL, Peak Temp. - The Moisture Sensitivity Level rating according to the JEDEC industry standard classifications, and peak solder temperature.

(4) There may be additional marking, which relates to the logo, the lot trace code information, or the environmental category on the device.

(5) Multiple Device Markings will be inside parentheses. Only one Device Marking contained in parentheses and separated by a "~" will appear on a device. If a line is indented then it is a continuation of the previous line and the two combined represent the entire Device Marking for that device.

(6) Lead finish/Ball material - Orderable Devices may have multiple material finish options. Finish options are separated by a vertical ruled line. Lead finish/Ball material values may wrap to two lines if the finish value exceeds the maximum column width.

Important Information and Disclaimer: The information provided on this page represents TI's knowledge and belief as of the date that it is provided. TI bases its knowledge and belief on information provided by third parties, and makes no representation or warranty as to the accuracy of such information. Efforts are underway to better integrate information from third parties. TI has taken and continues to take reasonable steps to provide representative and accurate information but may not have conducted destructive testing or chemical analysis on incoming materials and chemicals. TI and TI suppliers consider certain information to be proprietary, and thus CAS numbers and other limited information may not be available for release.

In no event shall TI's liability arising out of such information exceed the total purchase price of the TI part(s) at issue in this document sold by TI to Customer on an annual basis.

TAPE AND REEL INFORMATION

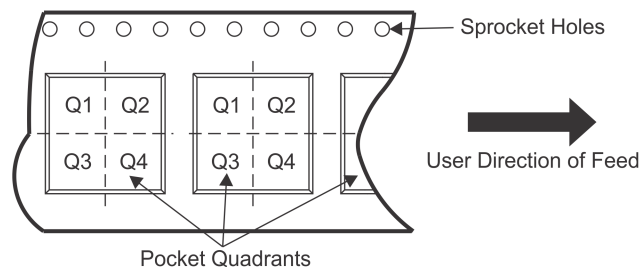
QUADRANT ASSIGNMENTS FOR PIN 1 ORIENTATION IN TAPE

*All dimensions are nominal

Device	Package Type	Package Drawing	Pins	SPQ	Reel Diameter (mm)	Reel Width W1 (mm)	A0 (mm)	B0 (mm)	K0 (mm)	P1 (mm)	W (mm)	Pin1 Quadrant
TPS62406QDRCRQ1	VSON	DRC	10	3000	330.0	12.4	3.3	3.3	1.1	8.0	12.0	Q2
TPS62407QDRCRQ1	VSON	DRC	10	3000	330.0	12.4	3.3	3.3	1.1	8.0	12.0	Q2
TPS62422QDRCRQ1	VSON	DRC	10	3000	330.0	12.4	3.3	3.3	1.1	8.0	12.0	Q2
TPS62423QDRCRQ1	VSON	DRC	10	3000	330.0	12.4	3.3	3.3	1.1	8.0	12.0	Q2
TPS62424QDRCRQ1	VSON	DRC	10	3000	330.0	12.4	3.3	3.3	1.1	8.0	12.0	Q2

TAPE AND REEL BOX DIMENSIONS

*All dimensions are nominal

Device	Package Type	Package Drawing	Pins	SPQ	Length (mm)	Width (mm)	Height (mm)
TPS62406QDRCRQ1	VSON	DRC	10	3000	367.0	367.0	35.0
TPS62407QDRCRQ1	VSON	DRC	10	3000	367.0	367.0	35.0
TPS62422QDRCRQ1	VSON	DRC	10	3000	338.0	355.0	50.0
TPS62423QDRCRQ1	VSON	DRC	10	3000	338.0	355.0	50.0
TPS62424QDRCRQ1	VSON	DRC	10	3000	338.0	355.0	50.0

GENERIC PACKAGE VIEW

DRC 10

VSON - 1 mm max height

3 x 3, 0.5 mm pitch

PLASTIC SMALL OUTLINE - NO LEAD

This image is a representation of the package family, actual package may vary.
Refer to the product data sheet for package details.

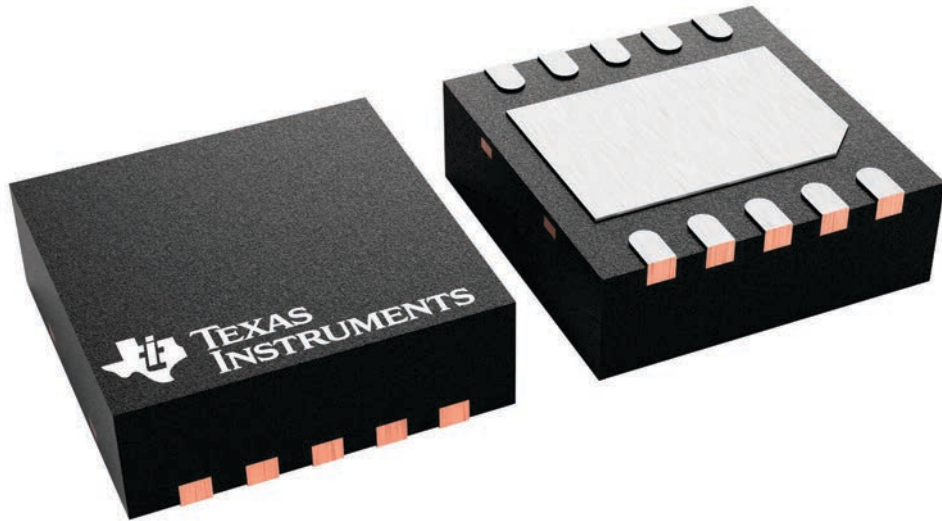

4226193/A

EXAMPLE BOARD LAYOUT

DRC0010J

VSON - 1 mm max height

PLASTIC SMALL OUTLINE - NO LEAD



LAND PATTERN EXAMPLE
EXPOSED METAL SHOWN
SCALE:20X



SOLDER MASK DETAILS

4218878/B 07/2018

NOTES: (continued)

4. This package is designed to be soldered to a thermal pad on the board. For more information, see Texas Instruments literature number SLUA271 (www.ti.com/lit/sluea271).
5. Vias are optional depending on application, refer to device data sheet. If any vias are implemented, refer to their locations shown on this view. It is recommended that vias under paste be filled, plugged or tented.

EXAMPLE STENCIL DESIGN

DRC0010J

VSON - 1 mm max height

PLASTIC SMALL OUTLINE - NO LEAD

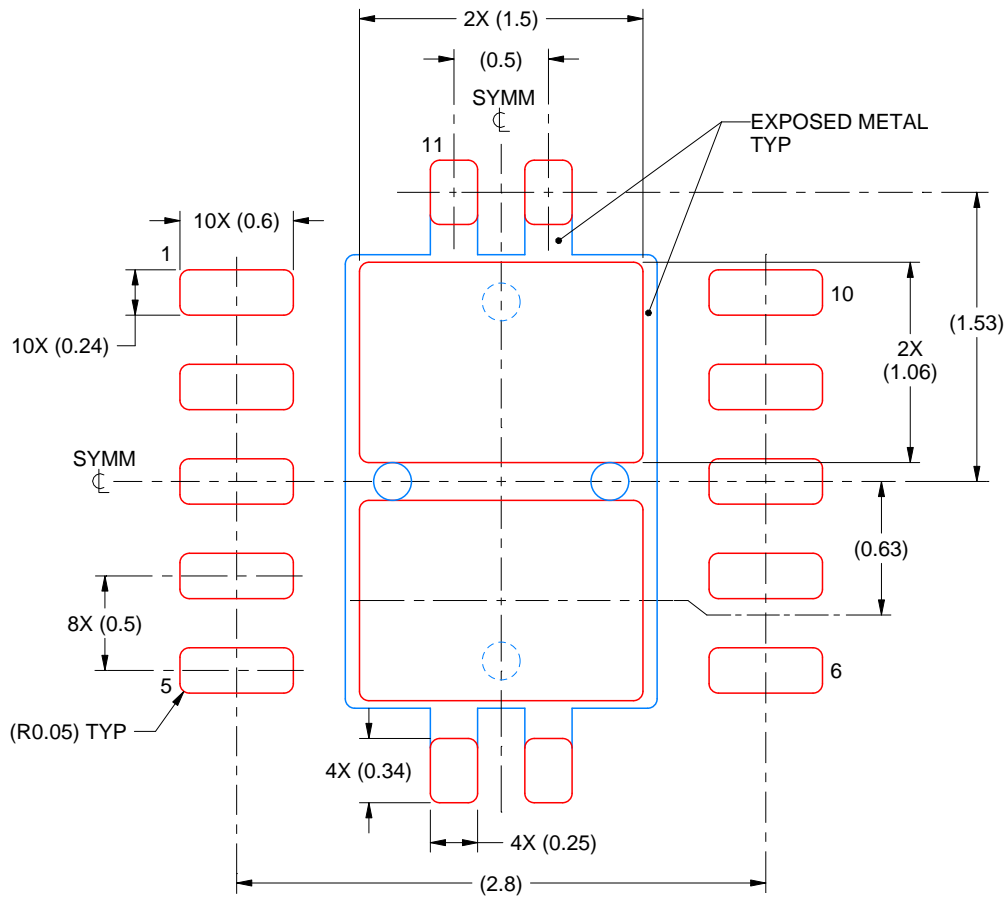

SOLDER PASTE EXAMPLE
BASED ON 0.125 mm THICK STENCIL

EXPOSED PAD 11:
80% PRINTED SOLDER COVERAGE BY AREA
SCALE:25X

4218878/B 07/2018

NOTES: (continued)

6. Laser cutting apertures with trapezoidal walls and rounded corners may offer better paste release. IPC-7525 may have alternate design recommendations.

重要声明和免责声明

TI 均以“原样”提供技术性及其可靠性数据（包括数据表）、设计资源（包括参考设计）、应用或其他设计建议、网络工具、安全信息和其他资源，不保证其中不含任何瑕疵，且不做任何明示或暗示的担保，包括但不限于对适销性、适合某特定用途或不侵犯任何第三方知识产权的暗示担保。

所述资源可供专业开发人员应用TI 产品进行设计使用。您将对以下行为独自承担全部责任：(1) 针对您的应用选择合适的TI 产品；(2) 设计、验证并测试您的应用；(3) 确保您的应用满足相应标准以及任何其他安全、安保或其他要求。所述资源如有变更，恕不另行通知。TI 对您使用所述资源的授权仅限于开发资源所涉及TI 产品的相关应用。除此之外不得复制或展示所述资源，也不提供其它TI 或任何第三方的知识产权授权许可。如因使用所述资源而产生任何索赔、赔偿、成本、损失及债务等，TI 对此概不负责，并且您须赔偿由此对TI 及其代表造成的损害。

TI 所提供产品均受TI 的销售条款 (<http://www.ti.com.cn/zh-cn/legal/termsofsale.html>) 以及ti.com.cn上或随附TI产品提供的其他可适用条款的约束。TI提供所述资源并不扩展或以其他方式更改TI 针对TI 产品所发布的可适用的担保范围或担保免责声明。

邮寄地址：上海市浦东新区世纪大道 1568 号中建大厦 32 楼，邮政编码：200122

Copyright © 2020 德州仪器半导体技术（上海）有限公司