

# TCA6424A 低电压 24 位 I<sup>2</sup>C 和系统管理总线 (SMBus) 输入输出 (I/O) 扩展器

## 具有中断输出、复位和配置寄存器

### 1 特性

- 1.65V 至 5.5V 的工作电源电压范围
- 允许下列端口间的双向电压电平转换和通用输入输出 (GPIO) 扩展：
  - 1.8V 串行时钟/串行数据 (SCL/SDA) 和 1.8V, 2.5V, 3.3V 或 5V P 端口
  - 2.5V SCL/SDA 和 1.8V, 2.5V, 3.3V 或 5V P 端口
  - 3.3V SCL/SDA 和 1.8V, 2.5V, 3.3V 或 5V P 端口
  - 5V SCL/SDA 和 1.8V, 2.5V, 3.3V 或 5V P 端口
- 到并行端口扩展器的 I<sup>2</sup>C
- 1 $\mu$ A 的低待机功耗
- 施密特触发器的运行可在 SCL 和 SDA 输入上实现缓输入转换和更好的开关噪声抗扰度
  - 1.8V 时,  $V_{hys} = 0.18V$  (典型值)
  - 2.5V 时,  $V_{hys} = 0.25V$  (典型值)
  - 3.3V 时,  $V_{hys} = 0.33V$  (典型值)
  - 5V 时,  $V_{hys} = 0.5V$  (典型值)
- 可耐受 5V 电压的 I/O 端口
- 低电平有效复位输入 ( $\overline{RESET}$ )
- 开漏低电平有效中断输出 ( $\overline{INT}$ )
- 400kHz 快速 I<sup>2</sup>C 总线
- 输入/输出配置寄存器
- 极性反转寄存器
- 内部加电复位
- 在所有通道均被配置为输入的情况下加电
- 在加电时无毛刺脉冲
- SCL/SDA 输入端上的噪声滤波器
- 针对直接驱动 LED 的具有高电流驱动最大能力的锁存输出
- 锁断性能超过 100mA, 符合 JESD 78 II 类规范的要求)
- 静电放电 (ESD) 保护性能超过 JESD 22 规范的要求
  - 2000V 人体模型 (A114-A)
  - 200V 机器模型 (A115-A)
  - 1000V 充电器件模型 (C101)

### 2 说明

这款针对两线制双向总线 (IC) 的 24 位 I/O 扩展器被设计成通过 I<sup>2</sup>C 接口 [串行时钟 (SCL) 和串行数据 (SDA)] 为大多数微控制器系列提供通用远程 I/O 扩展。

该器件的主要优势是其宽  $V_{CC}$  范围。在 P 端口侧和 SDA/SCL 侧, 它能够在 1.65V 至 5.5V 的电压范围内运行。这使得 TCA6424A 能够在 SDA/SCL 侧 (在这里, 电源电平正在降低以节约能耗) 与下一代微处理器和微控制器相连接。与微处理器和微控制器的电源电压不断走低不同, 有些印刷电路板 (PCB) 组件 (例如 LED) 保持在 5V 电源上。

#### 器件信息<sup>(1)</sup>

器件名称	封装	封装尺寸
TCA6424A	超薄四方扁平无引线 (UQFN) (32)	5mm x 5mm

(1) 如需了解所有可用封装, 请见数据表末尾的可订购产品附录。

#### RGJ/RSM 封装 (底视图)

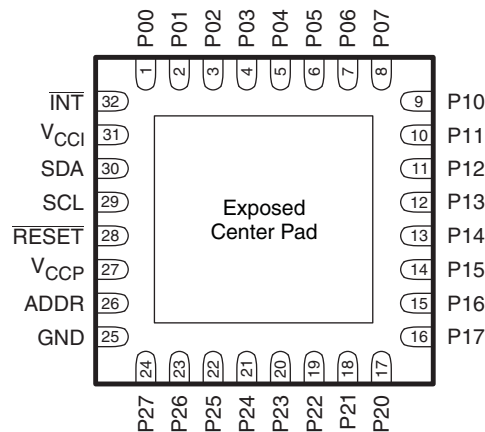

如果使用, 那么裸露的中央散热焊盘必须作为一个辅助地进行连接或置于电开路状态。

## 目录

<b>1 特性</b> ..... 1 <b>2 说明</b> ..... 1 <b>3 修订历史记录</b> ..... 2 <b>4 说明 (继续)</b> ..... 3 <b>5 Pin Configuration and Functions</b> ..... 4 <b>6 Specifications</b> ..... 5 6.1 Absolute Maximum Ratings ..... 5 6.2 Handling Ratings ..... 5 6.3 Recommended Operating Conditions ..... 5 6.4 Electrical Characteristics ..... 6 6.5 I <sup>2</sup> C Interface Timing Requirements ..... 7 6.6 Reset Timing Requirements ..... 7 6.7 Switching Characteristics ..... 7 6.8 Typical Characteristics ..... 8 <b>7 Parameter Measurement Information</b> ..... 11	<b>8 Detailed Description</b> ..... 15 8.1 Overview ..... 15 8.2 Functional Block Diagram ..... 16 8.3 Feature Description ..... 17 8.4 Programming ..... 19 8.5 Register Maps ..... 22 <b>9 Applications and Implementation</b> ..... 25 9.1 Typical Application ..... 25 <b>10 Power Supply Recommendation</b> ..... 27 <b>11 器件和文档支持</b> ..... 29 11.1 Trademarks ..... 29 11.2 Electrostatic Discharge Caution ..... 29 11.3 Glossary ..... 29 <b>12 机械封装和可订购信息</b> ..... 29
--	---

### 3 修订历史记录

Changes from Revision B (September 2010) to Revision C	Page
• 已删除硬编码的的订购信息表。 .....	1
• 已更新文档格式。 .....	1

Changes from Revision A (August 2010) to Revision B	Page
• 已对文档进行修改, 将文档状态从预览更新为生产数据。 .....	1

Changes from Original (July 2010) to Revision A	Page
• Changed Recommended Supply Sequencing and Rates Table .....	27

#### 4 说明 (继续)

TCA6424A 中的双向电压电平转换通过  $V_{CCI}$  来提供。 $V_{CCI}$  应连接至外部 SCL/SDA 线路的  $V_{CC}$ 。这用于指示接至 TCA6424A 的 I<sup>2</sup>C 总线的  $V_{CC}$  电平。TCA6424A P 端口上的电压电平由  $V_{CCP}$  来决定。

TCA6424A 包括 3 个 8 位配置 (输入或输出选择)、输入、输出和极性反转 (高电平有效) 寄存器。在加电时, I/O 被配置为输入。但是, 系统主控制器可以通过写入 I/O 配置位将 I/O 启用为输入或输出。针对每次输入或输出的数据保存在相应的输入或输出寄存器中。输入端口寄存器的极性可由极性反转寄存器转换。所有寄存器都可通过系统主控制器读取。

倘若发生超时或其他不当操作, 系统主控制器可以通过将  $\overline{RESET}$  输入置为低电平来复位 TCA6424A。加电复位将寄存器置于其缺省状态并对 I<sup>2</sup>C/SMBus 状态机进行初始化。 $\overline{RESET}$  引脚可在不切断部件供电的情况下引起相同的复位/初始化操作。

TCA6424A 开漏中断 ( $\overline{INT}$ ) 输出在任意输入状态不同于其对应的输入端口寄存器状态时被激活, 并用于向系统主控制器发出“一个输入状态已被改变”的指示信号。

$\overline{INT}$  可被连接至一个微控制器的中断输入。通过在这条线路上发送一个中断信号, 远程 I/O 可通知微控制器在其端口上是否存在输入数据, 而无须通过 I<sup>2</sup>C 总线进行通信。这样, TCA6424A 就能够保持为一款简单的从属器件。

该器件的 P 端口输出具有高电流吸收能力, 可在器件电流消耗很低的情况下直接驱动 LED。

可采用一个硬件引脚 (ADDR) 来设置和改变固定的 I<sup>2</sup>C 地址, 并且最多能允许 2 个器件共用同一根 I<sup>2</sup>C 总线或 SMBus。

## 5 Pin Configuration and Functions

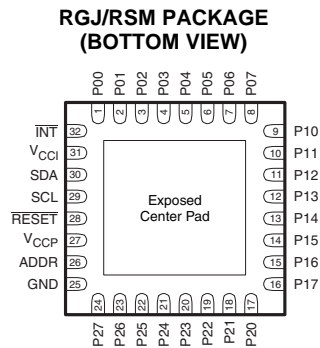

If used, the exposed center pad must be connected as a secondary ground or left electrically open.

### Pin Functions

PIN		DESCRIPTION
PIN NO.	NAME	
1	P00	P-port input/output (push-pull design structure). At power on, P00 is configured as an input.
2	P01	P-port input/output (push-pull design structure). At power on, P01 is configured as an input.
3	P02	P-port input/output (push-pull design structure). At power on, P02 is configured as an input.
4	P03	P-port input/output (push-pull design structure). At power on, P03 is configured as an input.
5	P04	P-port input/output (push-pull design structure). At power on, P04 is configured as an input.
6	P05	P-port input/output (push-pull design structure). At power on, P05 is configured as an input.
7	P06	P-port input/output (push-pull design structure). At power on, P06 is configured as an input.
8	P07	P-port input/output (push-pull design structure). At power on, P07 is configured as an input.
9	P10	P-port input/output (push-pull design structure). At power on, P10 is configured as an input.
10	P11	P-port input/output (push-pull design structure). At power on, P11 is configured as an input.
11	P12	P-port input/output (push-pull design structure). At power on, P12 is configured as an input.
12	P13	P-port input/output (push-pull design structure). At power on, P13 is configured as an input.
13	P14	P-port input/output (push-pull design structure). At power on, P14 is configured as an input.
14	P15	P-port input/output (push-pull design structure). At power on, P15 is configured as an input.
15	P16	P-port input/output (push-pull design structure). At power on, P16 is configured as an input.
16	P17	P-port input/output (push-pull design structure). At power on, P17 is configured as an input.
17	P20	P-port input/output (push-pull design structure). At power on, P20 is configured as an input.
18	P21	P-port input/output (push-pull design structure). At power on, P21 is configured as an input.
19	P22	P-port input/output (push-pull design structure). At power on, P22 is configured as an input.
20	P23	P-port input/output (push-pull design structure). At power on, P23 is configured as an input.
21	P24	P-port input/output (push-pull design structure). At power on, P24 is configured as an input.
22	P25	P-port input/output (push-pull design structure). At power on, P25 is configured as an input.
23	P26	P-port input/output (push-pull design structure). At power on, P26 is configured as an input.
24	P27	P-port input/output (push-pull design structure). At power on, P27 is configured as an input.
25	GND	Ground
26	ADDR	Address input. Connect directly to $V_{CCP}$ or ground.
27	$V_{CCP}$	Supply voltage of TCA6424A for P port
28	$\overline{RESET}$	Active-low reset input. Connect to $V_{CCI}$ through a pullup resistor, if no active connection is used.
29	SCL	Serial clock bus. Connect to $V_{CCI}$ through a pullup resistor.
30	SDA	Serial data bus. Connect to $V_{CCI}$ through a pullup resistor.
31	$V_{CCI}$	Supply voltage of I <sup>2</sup> C bus. Connect directly to the $V_{CC}$ of the external I <sup>2</sup> C master. Provides voltage-level translation.
32	$\overline{INT}$	Interrupt output. Connect to $V_{CCI}$ through a pullup resistor.

## 6 Specifications

### 6.1 Absolute Maximum Ratings<sup>(1)</sup>

over operating free-air temperature range (unless otherwise noted)

				MIN	MAX	UNIT
V <sub>CCI</sub>	Supply voltage range			-0.5	6.5	V
V <sub>CCP</sub>	Supply voltage range			-0.5	6.5	V
V <sub>I</sub>	Input voltage range <sup>(2)</sup>			-0.5	6.5	V
V <sub>O</sub>	Output voltage range <sup>(2)</sup>			-0.5	6.5	V
I <sub>IK</sub>	Input clamp current	ADDR, $\overline{\text{RESET}}$ , SCL	V <sub>I</sub> < 0		±20	mA
I <sub>OK</sub>	Output clamp current	$\overline{\text{INT}}$	V <sub>O</sub> < 0		±20	mA
I <sub>IOK</sub>	Input/output clamp current	P port	V <sub>O</sub> < 0 or V <sub>O</sub> > V <sub>CCP</sub>		±20	mA
		SDA	V <sub>O</sub> < 0 or V <sub>O</sub> > V <sub>CCI</sub>		±20	
I <sub>OL</sub>	Continuous output low current	P port	V <sub>O</sub> = 0 to V <sub>CCP</sub>		25	mA
		SDA, $\overline{\text{INT}}$	V <sub>O</sub> = 0 to V <sub>CCI</sub>		15	
I <sub>OH</sub>	Continuous output high current	P port	V <sub>O</sub> = 0 to V <sub>CCP</sub>		25	mA
I <sub>CC</sub>	Continuous current through GND				200	mA
	Continuous current through V <sub>CCP</sub>				160	
	Continuous current through V <sub>CCI</sub>				10	
θ <sub>JA</sub>	Package thermal impedance <sup>(3)</sup>		RGJ package		50.05	°C/W
			RSM package		TBD	

(1) Stresses beyond those listed under *Absolute Maximum Ratings* may cause permanent damage to the device. These are stress ratings only, and functional operation of the device at these or any other conditions beyond those indicated under *Recommended Operating Conditions* is not implied. Exposure to absolute-maximum-rated conditions for extended periods may affect device reliability.

(2) The input negative-voltage and output voltage ratings may be exceeded if the input and output current ratings are observed.

(3) The package thermal impedance is calculated in accordance with JESD 51-7.

### 6.2 Handling Ratings

				MIN	MAX	UNIT
T <sub>stg</sub>	Storage temperature range			-65	150	°C
V <sub>(ESD)</sub>	Electrostatic discharge	Human body model (HBM), per ANSI/ESDA/JEDEC JS-001, all pins <sup>(1)</sup>		0	2	kV
		Charged device model (CDM), per JEDEC specification JESD22-C101, all pins <sup>(2)</sup>		0	01	kV

(1) JEDEC document JEP155 states that 500-V HBM allows safe manufacturing with a standard ESD control process. Pins listed as 2000 V may actually have higher performance.

(2) JEDEC document JEP157 states that 250-V CDM allows safe manufacturing with a standard ESD control process. Pins listed as 2000 V may actually have higher performance.

### 6.3 Recommended Operating Conditions

				MIN	MAX	UNIT
V <sub>CCI</sub>	Supply voltage			1.65	5.5	V
V <sub>CCP</sub>	Supply voltage			1.65	5.5	V
V <sub>IH</sub>	High-level input voltage	SCL, SDA		0.7 × V <sub>CCI</sub>	V <sub>CCI</sub>	V
		$\overline{\text{RESET}}$		0.7 × V <sub>CCI</sub>	5.5	
		ADDR, P27–P00		0.7 × V <sub>CCP</sub>	5.5	
V <sub>IL</sub>	Low-level input voltage	SCL, SDA, $\overline{\text{RESET}}$		-0.5	0.3 × V <sub>CCI</sub>	V
		ADDR, P27–P00		-0.5	0.3 × V <sub>CCP</sub>	
I <sub>OH</sub>	High-level output current	P27–P00			10	mA
I <sub>OL</sub>	Low-level output current	P27–P00			25	mA
T <sub>A</sub>	Operating free-air temperature			-40	85	°C

## 6.4 Electrical Characteristics

 over recommended operating free-air temperature range,  $V_{CC1} = 1.65\text{ V to }5.5\text{ V}$  (unless otherwise noted)

PARAMETER		TEST CONDITIONS	$V_{CCP}$	MIN	TYP <sup>(1)</sup>	MAX	UNIT	
$V_{IK}$	Input diode clamp voltage	$I_I = -18\text{ mA}$	1.65 V to 5.5 V	-1.2			V	
$V_{POR}$	Power-on reset voltage	$V_I = V_{CCP}$ or GND, $I_O = 0$	1.65 V to 5.5 V		1	1.4	V	
$V_{OH}$	P-port high-level output voltage	$I_{OH} = -8\text{ mA}$	1.65 V	1.2			V	
			2.3 V	1.8				
			3 V	2.6				
			4.5 V	4.1				
		$I_{OH} = -10\text{ mA}$	1.65 V	1				
			2.3 V	1.7				
			3 V	2.5				
			4.5 V	4.0				
$V_{OL}$	P-port low-level output voltage	$I_{OL} = 8\text{ mA}$	1.65 V			0.45	V	
			2.3 V			0.25		
			3 V			0.25		
			4.5 V			0.23		
		$I_{OL} = 10\text{ mA}$	1.65 V			0.6		
			2.3 V			0.3		
			3 V			0.25		
			4.5 V			0.24		
$I_{OL}$	SDA	$V_{OL} = 0.4\text{ V}$	1.65 V to 5.5 V	3			mA	
	$\overline{\text{INT}}$	$V_{OL} = 0.4\text{ V}$	1.65 V to 5.5 V	3	15			
$I_I$	SCL, SDA, $\overline{\text{RESET}}$	$V_I = V_{CC1}$ or GND	1.65 V to 5.5 V			$\pm 0.1$	$\mu\text{A}$	
	ADDR	$V_I = V_{CCP}$ or GND				$\pm 0.1$		
$I_{IH}$	P port	$V_I = V_{CCP}$	1.65 V to 5.5 V			1	$\mu\text{A}$	
$I_{IL}$	P port	$V_I = \text{GND}$				1	$\mu\text{A}$	
$I_{CC}$ ( $I_{CCP} + I_{CCI}$ )	Operating mode	SDA, P port, ADDR, $\overline{\text{RESET}}$	$V_I$ on SDA and $\overline{\text{RESET}} = V_{CC1}$ or GND, $V_I$ on P port and ADDR = $V_{CCP}$ , $I_O = 0$ , I/O = inputs, $f_{SCL} = 400\text{ kHz}$	1.65 V to 5.5 V		8	30	$\mu\text{A}$
		SDA, P port, ADDR, $\overline{\text{RESET}}$	$V_I$ on SDA and $\overline{\text{RESET}} = V_{CC1}$ or GND, $V_I$ on P port and ADDR = $V_{CCP}$ , $I_O = 0$ , I/O = inputs, $f_{SCL} = 100\text{ kHz}$	1.65 V to 5.5 V		1.7	10	
	Standby mode	SCL, SDA, P port, ADDR, $\overline{\text{RESET}}$	$V_I$ on SCL, SDA and $\overline{\text{RESET}} = V_{CC1}$ or GND, $V_I$ on P port and ADDR = $V_{CCP}$ , $I_O = 0$ , I/O = inputs, $f_{SCL} = 0$	1.65 V to 5.5 V		0.1	3	
$\Delta I_{CCI}$	Additional current in Standby mode	SCL, SDA, $\overline{\text{RESET}}$	One input at $V_{CC1} - 0.6\text{ V}$ , Other inputs at $V_{CC1}$ or GND	1.65 V to 5.5 V		25	$\mu\text{A}$	
$\Delta I_{CCP}$		P port, ADDR,	One input at $V_{CCP} - 0.6\text{ V}$ , Other inputs at $V_{CCP}$ or GND			60		
$C_I$	SCL	$V_I = V_{CC1}$ or GND	1.65 V to 5.5 V		6	7	pF	
$C_{IO}$	SDA	$V_{IO} = V_{CC1}$ or GND	1.65 V to 5.5 V		7	8	pF	
	P port	$V_{IO} = V_{CCP}$ or GND			7.5	8.5		

(1) Except for  $I_{CC}$ , all typical values are at nominal supply voltage ( $V_{CCP} = V_{CC1} = 1.8\text{-V, }2.5\text{-V, }3.3\text{-V, or }5\text{-V }V_{CC}$ ) and  $T_A = 25^\circ\text{C}$ . For  $I_{CC}$ , all typical values are at  $V_{CCP} = V_{CC1} = 3.3\text{ V}$  and  $T_A = 25^\circ\text{C}$ .

## 6.5 I<sup>2</sup>C Interface Timing Requirements

over recommended operating free-air temperature range (unless otherwise noted) (see Figure 14)

		STANDARD MODE I <sup>2</sup> C BUS		FAST MODE I <sup>2</sup> C BUS		UNIT
		MIN	MAX	MIN	MAX	
t <sub>scl</sub>	I <sup>2</sup> C clock frequency	0	100	0	400	kHz
t <sub>sch</sub>	I <sup>2</sup> C clock high time	4		0.6		μs
t <sub>scl</sub>	I <sup>2</sup> C clock low time	4.7		1.3		μs
t <sub>sp</sub>	I <sup>2</sup> C spike time	0	50	0	50	ns
t <sub>sds</sub>	I <sup>2</sup> C serial data setup time	250		100		ns
t <sub>sdh</sub>	I <sup>2</sup> C serial data hold time	0		0		ns
t <sub>icr</sub>	I <sup>2</sup> C input rise time		1000	20 + 0.1C <sub>b</sub> <sup>(1)</sup>	300	ns
t <sub>icf</sub>	I <sup>2</sup> C input fall time		300	20 + 0.1C <sub>b</sub> <sup>(1)</sup>	300	ns
t <sub>ocf</sub>	I <sup>2</sup> C output fall time; 10 pF to 400 pF bus		300	20 + 0.1C <sub>b</sub> <sup>(1)</sup>	300	μs
t <sub>buf</sub>	I <sup>2</sup> C bus free time between Stop and Start	4.7		1.3		μs
t <sub>sts</sub>	I <sup>2</sup> C Start or repeater Start condition setup time	4.7		0.6		μs
t <sub>sth</sub>	I <sup>2</sup> C Start or repeater Start condition hold time	4		0.6		μs
t <sub>sps</sub>	I <sup>2</sup> C Stop condition setup time	4		0.6		μs
t <sub>vd(data)</sub>	Valid data time; SCL low to SDA output valid		1		1	μs
t <sub>vd(ack)</sub>	Valid data time of ACK condition; ACK signal from SCL low to SDA (out) low		1		1	μs

(1) C<sub>b</sub> = total capacitance of one bus line in pF

## 6.6 Reset Timing Requirements

over recommended operating free-air temperature range (unless otherwise noted) (see Figure 17)

		STANDARD MODE I <sup>2</sup> C BUS		FAST MODE I <sup>2</sup> C BUS		UNIT
		MIN	MAX	MIN	MAX	
t <sub>W</sub>	Reset pulse duration	4		4		ns
t <sub>REC</sub>	Reset recovery time	0		0		ns
t <sub>RESET</sub>	Time to reset <sup>(1)</sup>	600		600		ns

(1) Minimum time for SDA to become high or minimum time to wait before doing a START.

## 6.7 Switching Characteristics

over recommended operating free-air temperature range, C<sub>L</sub> ≤ 100 pF (unless otherwise noted) (see Figure 14)

PARAMETER	FROM	TO	STANDARD MODE I <sup>2</sup> C BUS		FAST MODE I <sup>2</sup> C BUS		UNIT
			MIN	MAX	MIN	MAX	
t <sub>IV</sub>	Interrupt valid time	P port		4		4	μs
t <sub>IR</sub>	Interrupt reset delay time	SCL		4		4	μs
t <sub>PV</sub>	Output data valid	SCL		400		400	ns
t <sub>PS</sub>	Input data setup time	P port	0		0		ns
t <sub>PH</sub>	Input data hold time	P port	300		300		ns

### 6.8 Typical Characteristics

$T_A = 25^\circ\text{C}$  (unless otherwise noted)

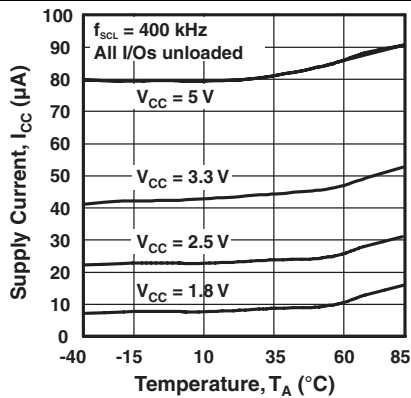

Figure 1. Supply Current vs Temperature

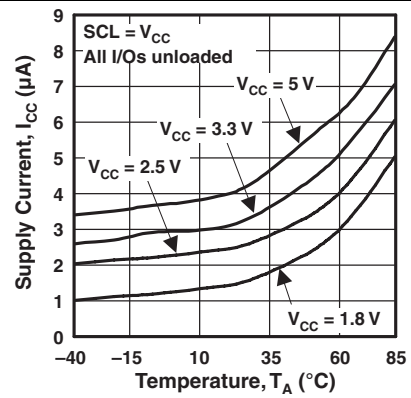

Figure 2. Standby Supply Current vs Temperature

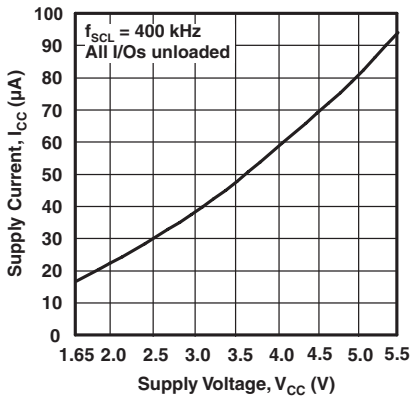

Figure 3. Supply Current vs Supply Voltage

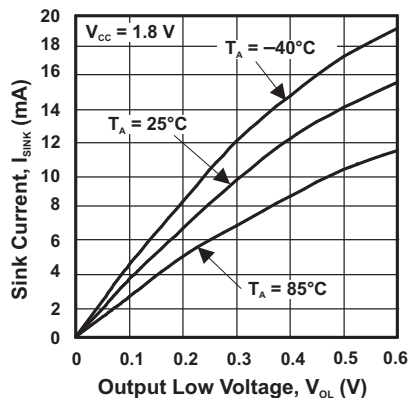

Figure 4. I/O Sink Current vs Output Low Voltage

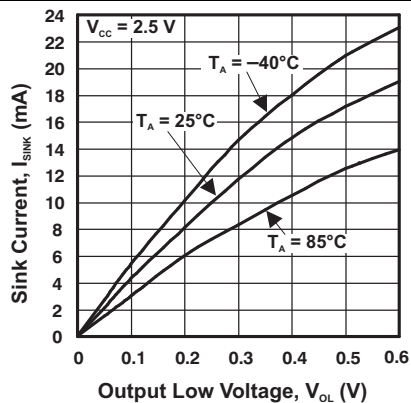

Figure 5. I/O Sink Current vs Output Low Voltage

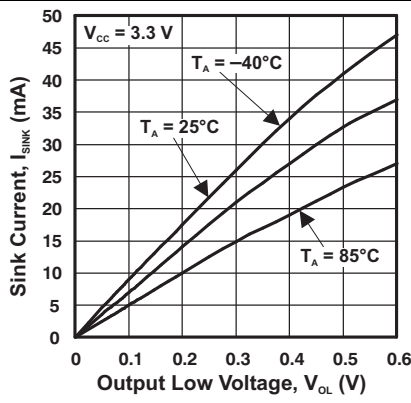

Figure 6. I/O Sink Current vs Output Low Voltage

Typical Characteristics (continued)

$T_A = 25^\circ\text{C}$  (unless otherwise noted)

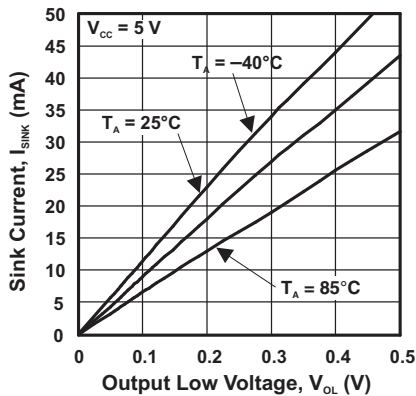

Figure 7. I/O Sink Current vs Output Low Voltage

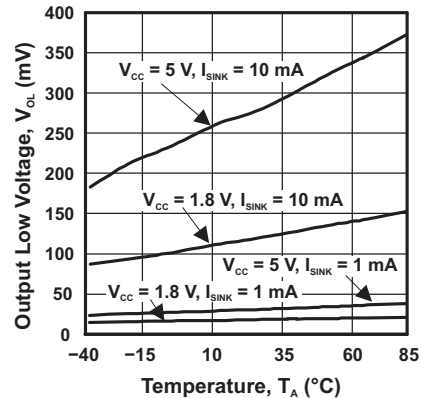

Figure 8. I/O Low Voltage vs Temperature

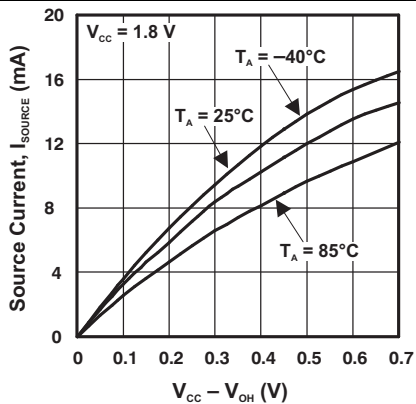

Figure 9. I/O Source Current vs Output High Voltage

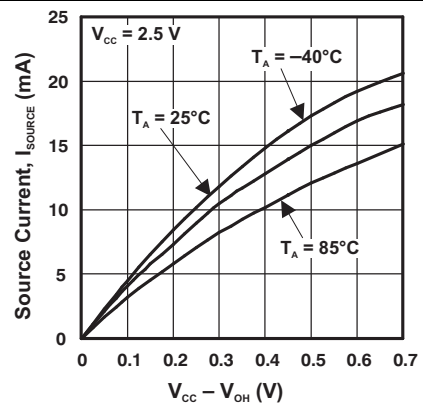

Figure 10. I/O Source Current vs Output High Voltage

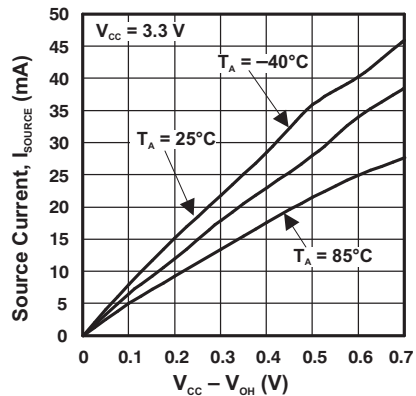

Figure 11. I/O Source Current vs Output High Voltage

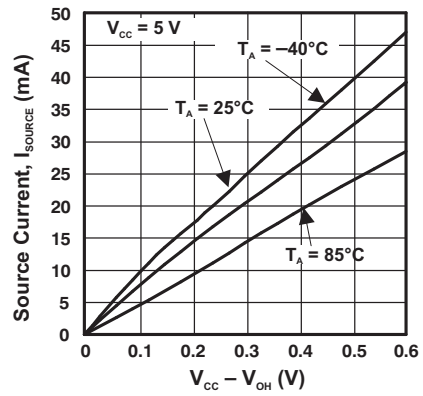
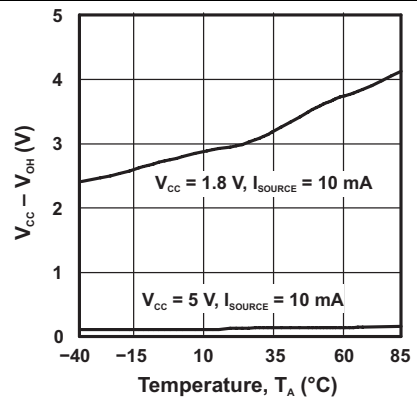
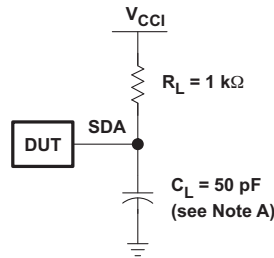

Figure 12. I/O Source Current vs Output High Voltage

**Typical Characteristics (continued)**
 $T_A = 25^\circ\text{C}$  (unless otherwise noted)

**Figure 13. I/O High Voltage vs Temperature**

## 7 Parameter Measurement Information

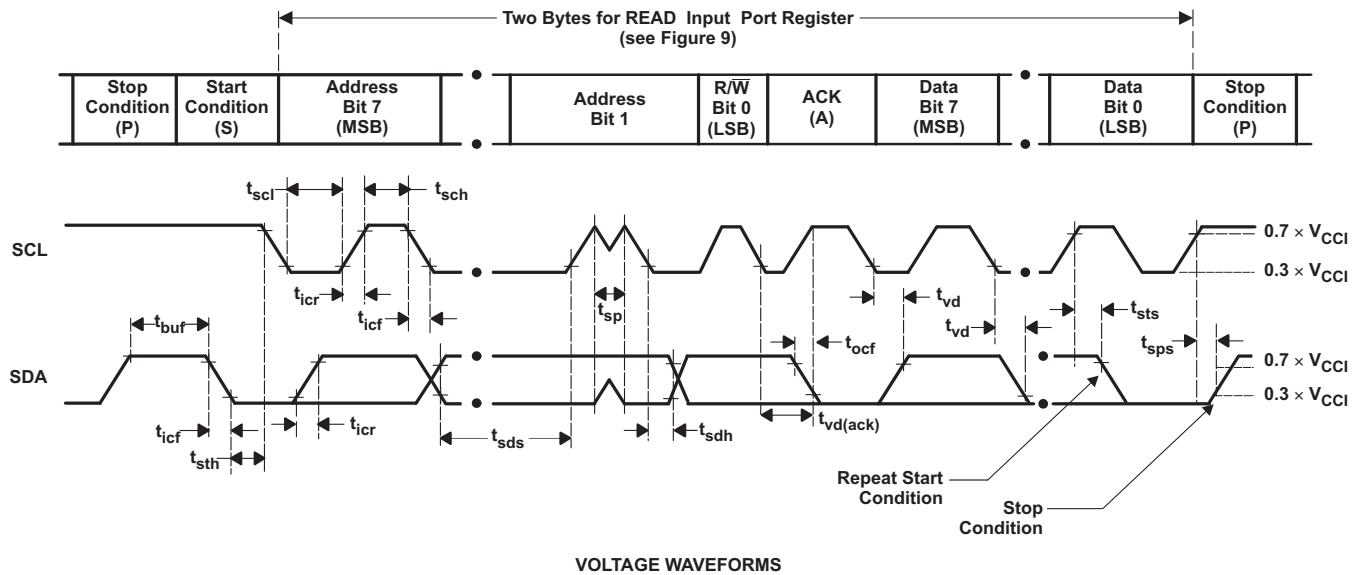

SDA LOAD CONFIGURATION



VOLTAGE WAVEFORMS

BYTE	DESCRIPTION
1	I <sup>2</sup> C address
2	Input register port data

- A.  $C_L$  includes probe and jig capacitance.  $t_{ocf}$  is measured with  $C_L$  of 10 pF or 400 pF.
- B. All inputs are supplied by generators having the following characteristics:  $PRR \leq 10$  MHz,  $Z_O = 50 \Omega$ ,  $t_r/t_f \leq 30$  ns.
- C. All parameters and waveforms are not applicable to all devices.

Figure 14. I<sup>2</sup>C Interface Load Circuit and Voltage Waveforms

Parameter Measurement Information (continued)

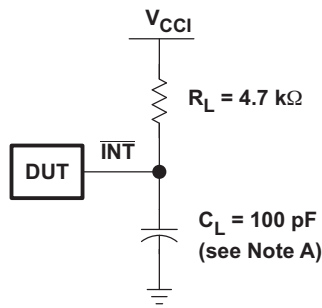

INTERRUPT LOAD CONFIGURATION

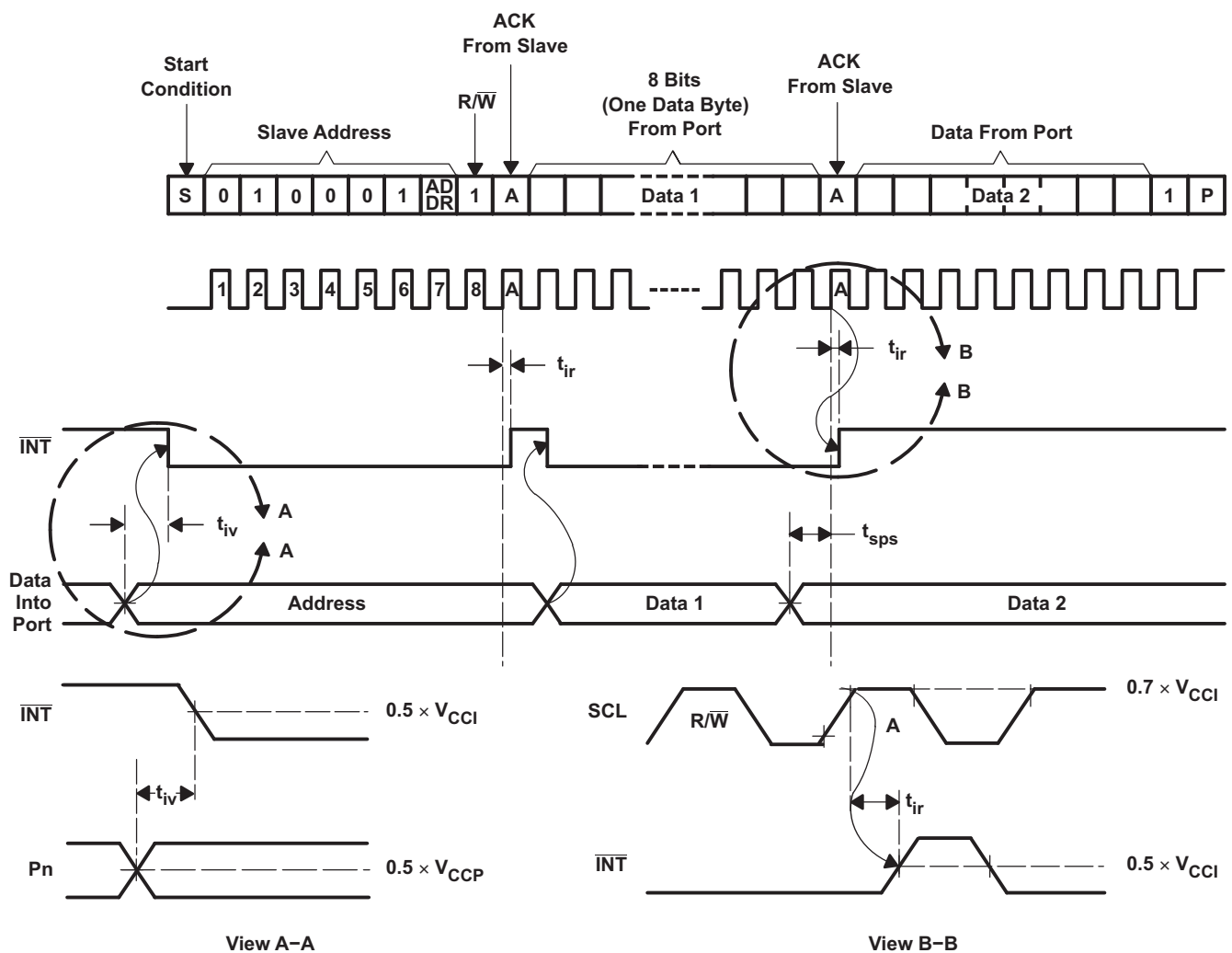

- A.  $C_L$  includes probe and jig capacitance.
- B. All inputs are supplied by generators having the following characteristics:  $PRR \leq 10$  MHz,  $Z_O = 50 \Omega$ ,  $t_r/t_f \leq 30$  ns.
- C. All parameters and waveforms are not applicable to all devices.

Figure 15. Interrupt Load Circuit and Voltage Waveforms

Parameter Measurement Information (continued)

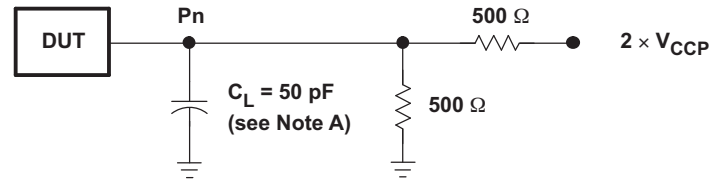

P PORT LOAD CONFIGURATION

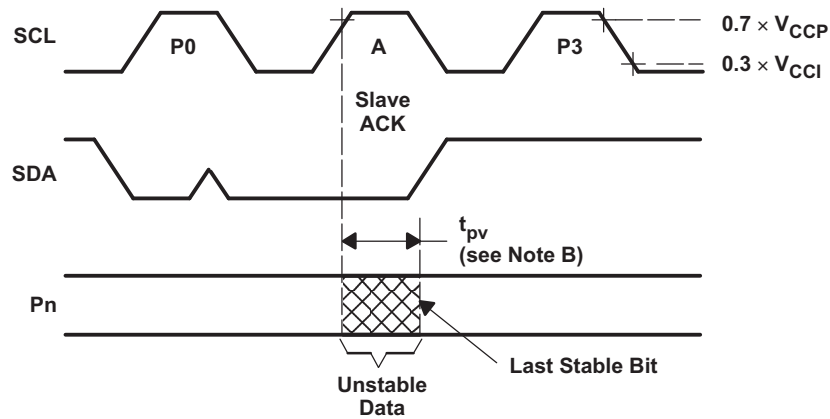

WRITE MODE ( $R/\bar{W} = 0$ )

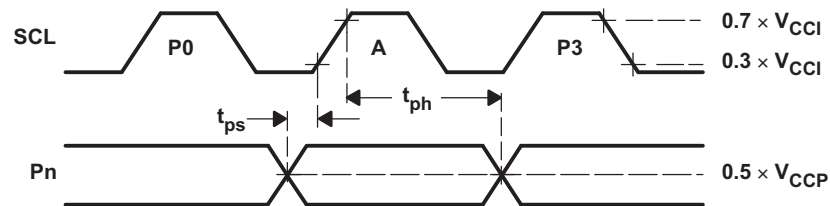

READ MODE ( $R/\bar{W} = 1$ )

- A.  $C_L$  includes probe and jig capacitance.
- B.  $t_{pv}$  is measured from  $0.7 \times V_{CC}$  on SCL to 50% I/O (Pn) output.
- C. All inputs are supplied by generators having the following characteristics: PRR  $\leq$  10 MHz,  $Z_0 = 50 \Omega$ ,  $t_r/t_f \leq 30$  ns.
- D. The outputs are measured one at a time, with one transition per measurement.
- E. All parameters and waveforms are not applicable to all devices.

Figure 16. P-Port Load Circuit and Timing Waveforms

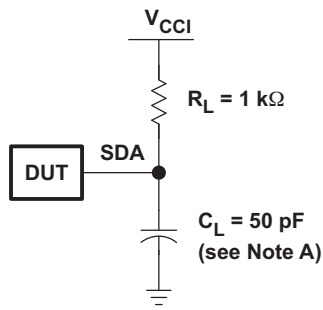
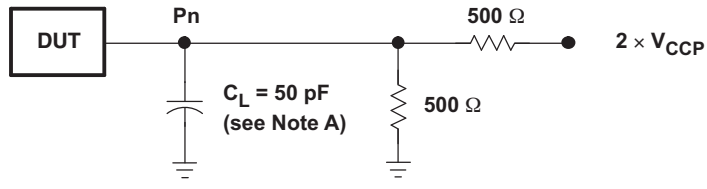
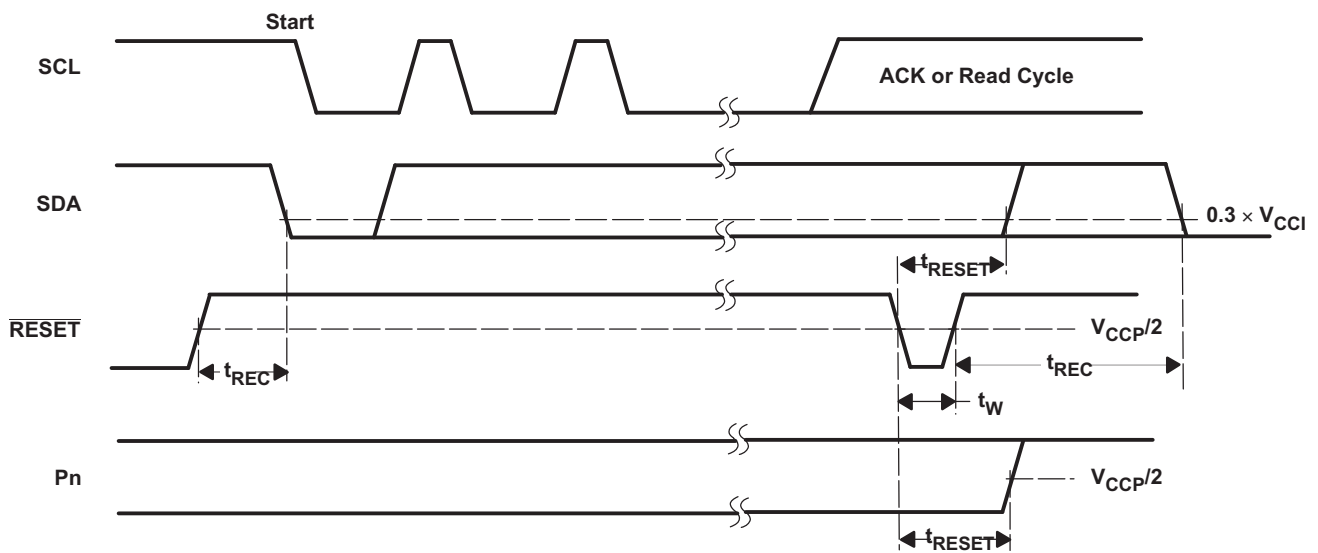
**Parameter Measurement Information (continued)**

**SDA LOAD CONFIGURATION**

**P PORT LOAD CONFIGURATION**

- A.  $C_L$  includes probe and jig capacitance.
- B. All inputs are supplied by generators having the following characteristics:  $PRR \leq 10\text{ MHz}$ ,  $Z_O = 50\ \Omega$ ,  $t_r/t_f \leq 30\text{ ns}$ .
- C. The outputs are measured one at a time, with one transition per measurement.
- D. I/Os are configured as inputs.
- E. All parameters and waveforms are not applicable to all devices.

**Figure 17. Reset Load Circuits and Voltage Waveforms**

## 8 Detailed Description

### 8.1 Overview

#### 8.1.1 Voltage Translation

Table 1 shows how to set up  $V_{CC}$  levels for the necessary voltage translation between the I<sup>2</sup>C bus and the TCA6424A.

**Table 1. Voltage Translation**

$V_{CCI}$ (SDA AND SCL OF I <sup>2</sup> C MASTER) (V)	$V_{CCP}$ (P PORT) (V)
1.8	1.8
1.8	2.5
1.8	3.3
1.8	5
2.5	1.8
2.5	2.5
2.5	3.3
2.5	5
3.3	1.8
3.3	2.5
3.3	3.3
3.3	5
5	1.8
5	2.5
5	3.3
5	5

## 8.2 Functional Block Diagram

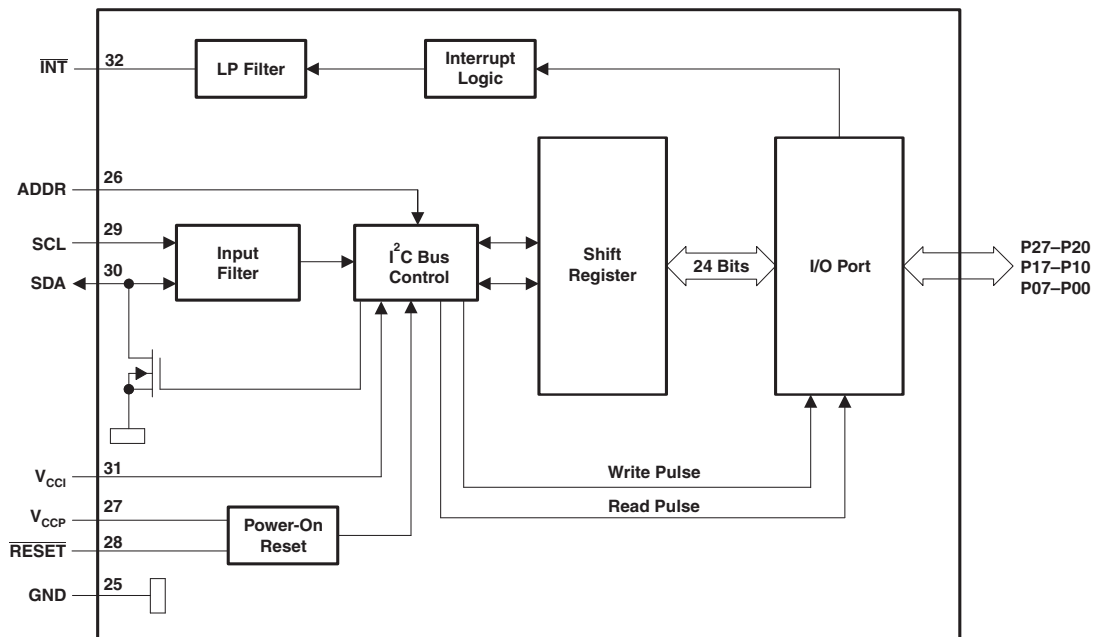

- A. All I/Os are set to inputs at reset.
- B. Pin numbers shown are for the RGJ package.

Figure 18. Positive Logic

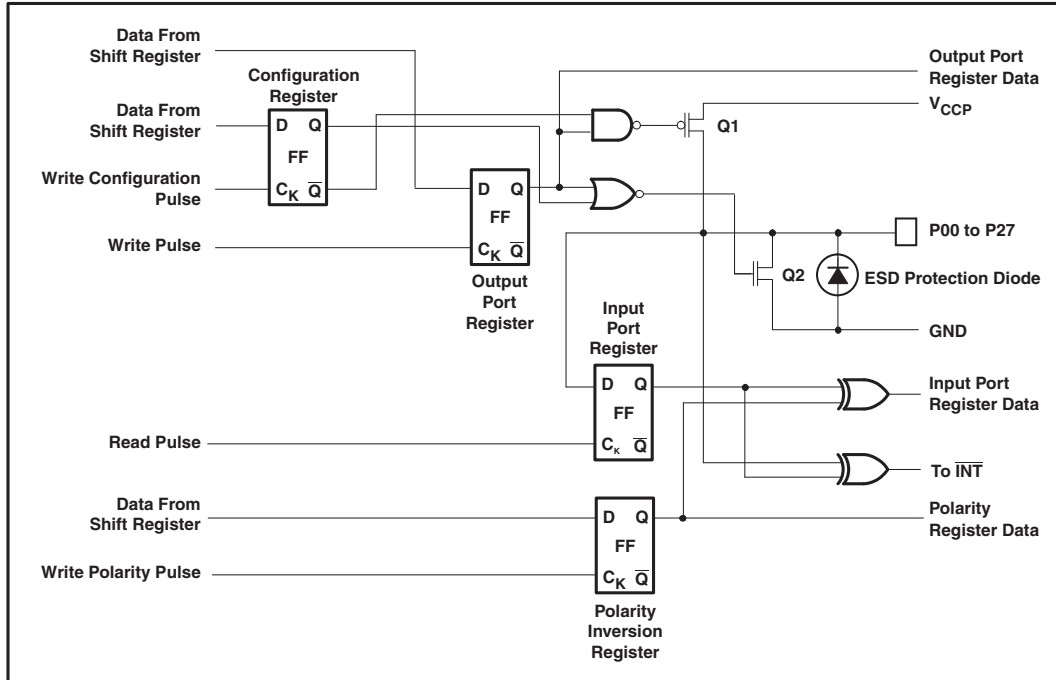

- A. On power up or reset, all registers return to default values.

Figure 19. Simplified Schematic of P00 to P27

### 8.3 Feature Description

#### 8.3.1 I/O Port

When an I/O is configured as an input, FETs Q1 and Q2 are off, which creates a high-impedance input. The input voltage may be raised above  $V_{CC}$  to a maximum of 5.5 V.

If the I/O is configured as an output, Q1 or Q2 is enabled, depending on the state of the output port register. In this case, there are low-impedance paths between the I/O pin and either  $V_{CC}$  or GND. The external voltage applied to this I/O pin should not exceed the recommended levels for proper operation.

#### 8.3.2 I<sup>2</sup>C Interface

The bidirectional I<sup>2</sup>C bus consists of the serial clock (SCL) and serial data (SDA) lines. Both lines must be connected to a positive supply through a pullup resistor when connected to the output stages of a device. Data transfer may be initiated only when the bus is not busy.

I<sup>2</sup>C communication with this device is initiated by a master sending a Start condition, a high-to-low transition on the SDA input/output, while the SCL input is high (see Figure 20). After the Start condition, the device address byte is sent, most significant bit (MSB) first, including the data direction bit (R/W).

After receiving the valid address byte, this device responds with an acknowledge (ACK), a low on the SDA input/output during the high of the ACK-related clock pulse. The address (ADDR) input of the slave device must not be changed between the Start and the Stop conditions.

On the I<sup>2</sup>C bus, only one data bit is transferred during each clock pulse. The data on the SDA line must remain stable during the high pulse of the clock period, as changes in the data line at this time are interpreted as control commands (Start or Stop) (see Figure 21).

A Stop condition, a low-to-high transition on the SDA input/output while the SCL input is high, is sent by the master (see Figure 20).

Any number of data bytes can be transferred from the transmitter to receiver between the Start and the Stop conditions. Each byte of eight bits is followed by one ACK bit. The transmitter must release the SDA line before the receiver can send an ACK bit. The device that acknowledges must pull down the SDA line during the ACK clock pulse, so that the SDA line is stable low during the high pulse of the ACK-related clock period (see Figure 22). When a slave receiver is addressed, it must generate an ACK after each byte is received. Similarly, the master must generate an ACK after each byte that it receives from the slave transmitter. Setup and hold times must be met to ensure proper operation.

A master receiver signals an end of data to the slave transmitter by not generating an acknowledge (NACK) after the last byte has been clocked out of the slave. This is done by the master receiver by holding the SDA line high. In this event, the transmitter must release the data line to enable the master to generate a Stop condition.

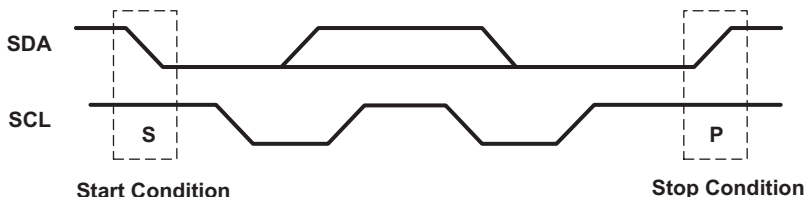

Figure 20. Definition of Start and Stop Conditions

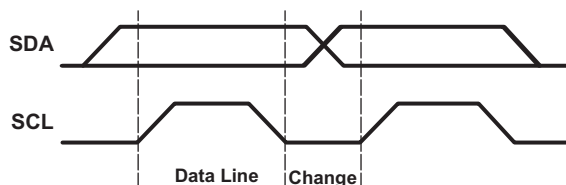

Figure 21. Bit Transfer

Feature Description (continued)

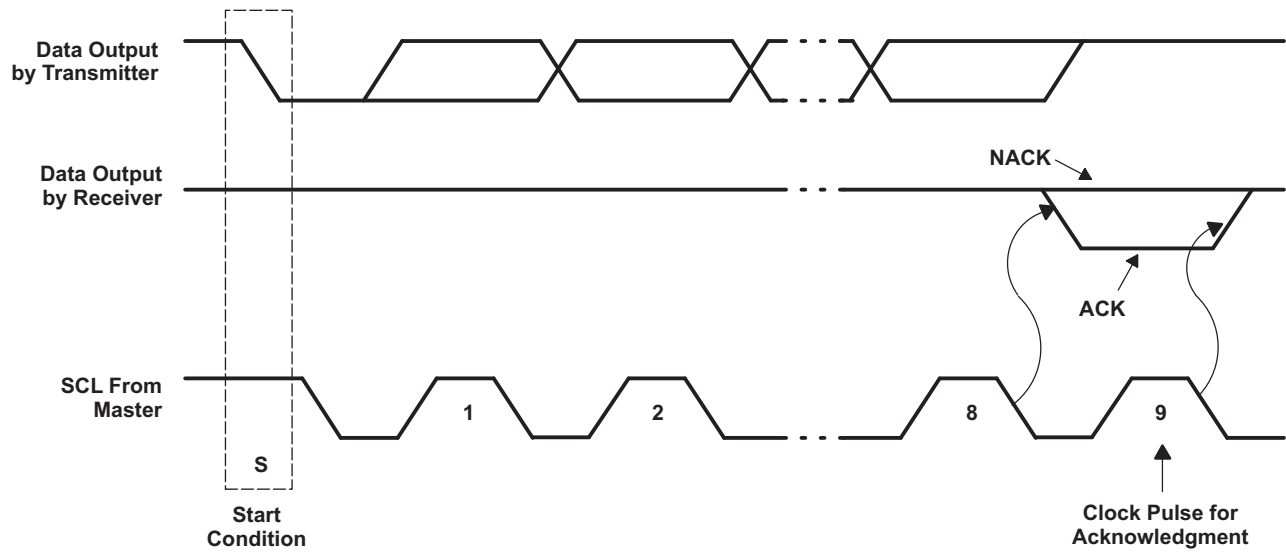

Figure 22. Acknowledgment on the I<sup>2</sup>C Bus

Feature Description (continued)

Table 2. Interface Definition

BYTE	BIT							
	7 (MSB)	6	5	4	3	2	1	0 (LSB)
I <sup>2</sup> C slave address	L	H	L	L	L	H	ADDR	R/W
I/O data bus	P07	P06	P05	P04	P03	P02	P01	P00
	P17	P16	P15	P14	P13	P12	P11	P10
	P27	P26	P25	P24	P23	P22	P21	P20

8.3.3 Device Address

The address of the TCA6424A is shown in Figure 23.

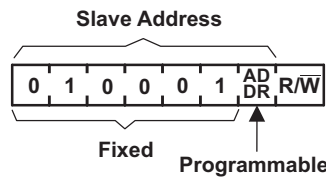

Figure 23. TCA6424A Address

Table 3. Address Reference

ADDR	I <sup>2</sup> C BUS SLAVE ADDRESS
L	34 (decimal), 22 (hexadecimal)
H	35 (decimal), 23 (hexadecimal)

The last bit of the slave address defines the operation (read or write) to be performed. A high (1) selects a read operation, while a low (0) selects a write operation.

8.4 Programming

8.4.1 Power-On Reset

When power (from 0 V) is applied to V<sub>CCP</sub>, an internal power-on reset holds the TCA6424A in a reset condition until V<sub>CCP</sub> has reached V<sub>POR</sub>. At that time, the reset condition is released, and the TCA6424A registers and I<sup>2</sup>C/SMBus state machine initializes to their default states. After that, V<sub>CCP</sub> must be lowered to below 0.2 V and back up to the operating voltage for a power-reset cycle.

8.4.2 Reset Input ( $\overline{\text{RESET}}$ )

The  $\overline{\text{RESET}}$  input can be asserted to initialize the system while keeping the V<sub>CCP</sub> at its operating level. A reset can be accomplished by holding the  $\overline{\text{RESET}}$  pin low for a minimum of t<sub>w</sub>. The TCA6424A registers and I<sup>2</sup>C/SMBus state machine are changed to their default state once  $\overline{\text{RESET}}$  is low (0). When  $\overline{\text{RESET}}$  is high (1), the I/O levels at the P port can be changed externally or through the master. This input requires a pullup resistor to V<sub>CCI</sub>, if no active connection is used.

8.4.3 Interrupt Output ( $\overline{\text{INT}}$ )

An interrupt is generated by any rising or falling edge of the port inputs in the input mode. After time t<sub>iv</sub>, the signal INT is valid. Resetting the interrupt circuit is achieved when data on the port is changed to the original setting or when data is read from the port that generated the interrupt. Resetting occurs in the read mode at the acknowledge (ACK) or not acknowledge (NACK) bit after the rising edge of the SCL signal. Interrupts that occur during the ACK or NACK clock pulse can be lost (or be very short) due to the resetting of the interrupt during this pulse. Each change of the I/Os after resetting is detected and is transmitted as  $\overline{\text{INT}}$ .

Reading from or writing to another device does not affect the interrupt circuit, and a pin configured as an output cannot cause an interrupt. Changing an I/O from an output to an input may cause a false interrupt to occur, if the state of the pin does not match the contents of the Input Port register.

## Programming (continued)

The  $\overline{\text{INT}}$  output has an open-drain structure and requires pullup resistor to  $V_{\text{CCP}}$  or  $V_{\text{CCI}}$  depending on the application. If the  $\overline{\text{INT}}$  signal is connected back to the processor that provides the SCL signal to the TCA6424A then the  $\overline{\text{INT}}$  pin has to be connected to  $V_{\text{CCI}}$ . If not, the  $\overline{\text{INT}}$  pin can be connected to  $V_{\text{CCP}}$ .

### 8.4.4 Bus Transactions

Data is exchanged between the master and TCA6424A through write and read commands.

#### 8.4.4.1 Writes

Data is transmitted to the TCA6424A by sending the device address and setting the least-significant bit (LSB) to a logic 0 (see Figure 23 for device address). The command byte is sent after the address and determines which register receives the data that follows the command byte. There is no limitation on the number of data bytes sent in one write transmission.

The twelve registers within the TCA6424A are grouped into four different sets. The four sets of registers are input ports, output ports, polarity inversion ports and configuration ports. After sending data to one register, the next data byte is sent to the next register in the group of 3 registers (see Figure 24 and Figure 25). For example, if the first byte is sent to Output Port 2 (register 6), the next byte is stored in Output Port 0 (register 4).

There is no limitation on the number of data bytes sent in one write transmission. In this way, each 8-bit register may be updated independently of the other registers.

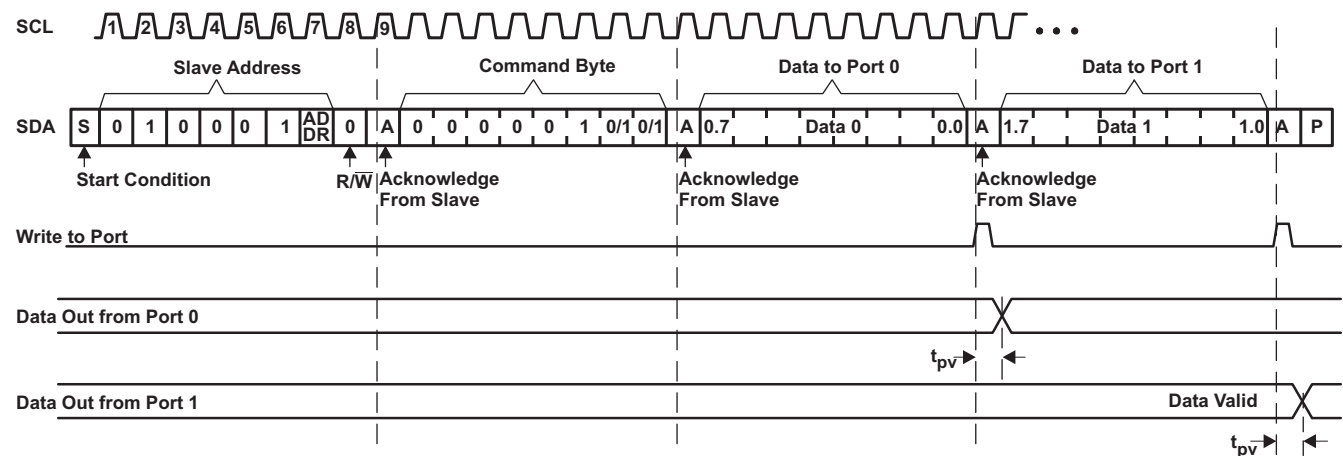

**Figure 24. Write to Output Port Register**

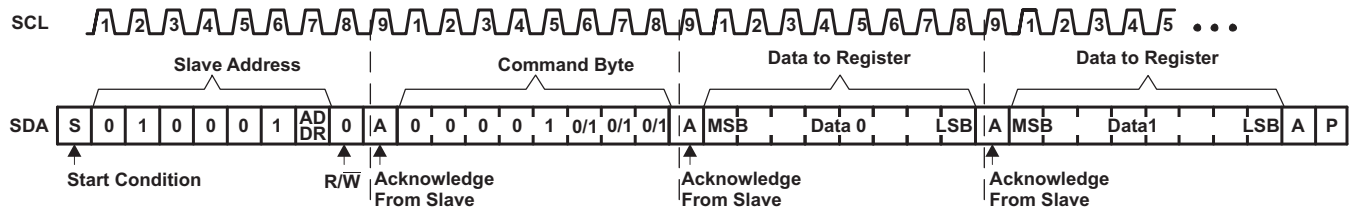

**Figure 25. Write to Configuration or Polarity Inversion Registers**

#### 8.4.4.2 Reads

The bus master first must send the TCA6424A address with the LSB set to a logic 0 (see Figure 23 for device address). The command byte is sent after the address and determines which register is accessed.

After a restart, the device address is sent again but, this time, the LSB is set to a logic 1. Data from the register defined by the command byte then is sent by the TCA6424A (see Figure 26 and Figure 27).

### Programming (continued)

After a restart, the value of the register defined by the command byte matches the register being accessed when the restart occurred. For example, if the command byte references Input Port 1 before the restart, and the restart occurs when Input Port 0 is being read, the stored command byte changes to reference Input Port 0. The original command byte is forgotten. If a subsequent restart occurs, Input Port 0 is read first. Data is clocked into the register on the rising edge of the ACK clock pulse. After the first byte is read, additional bytes may be read, but the data now reflects the information in the other register in the pair. For example, if Input Port 1 is read, the next byte read is Input Port 0.

Data is clocked into the register on the rising edge of the ACK clock pulse. There is no limitation on the number of data bytes received in one read transmission, but when the final byte is received, the bus master must not acknowledge the data.

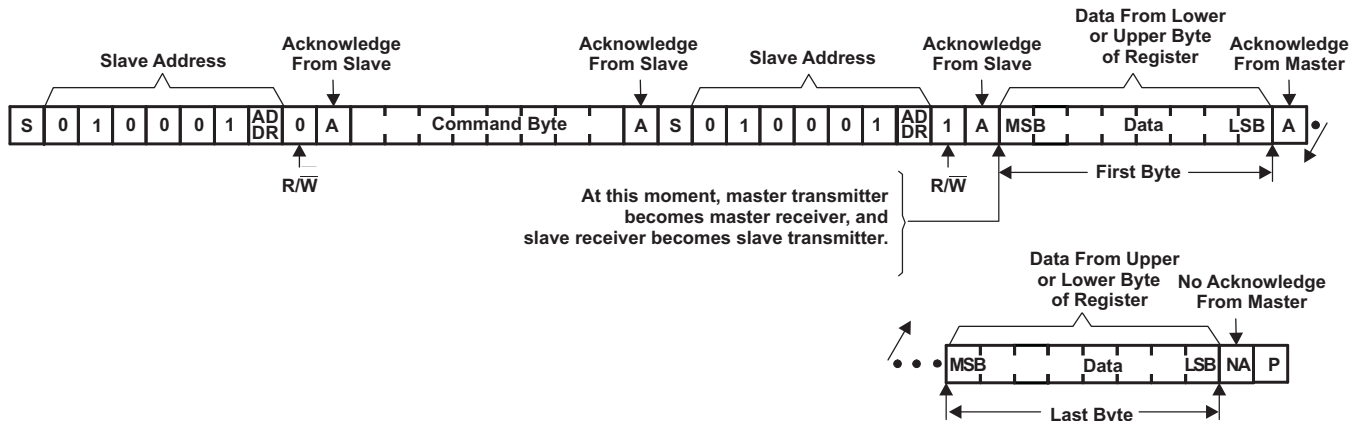
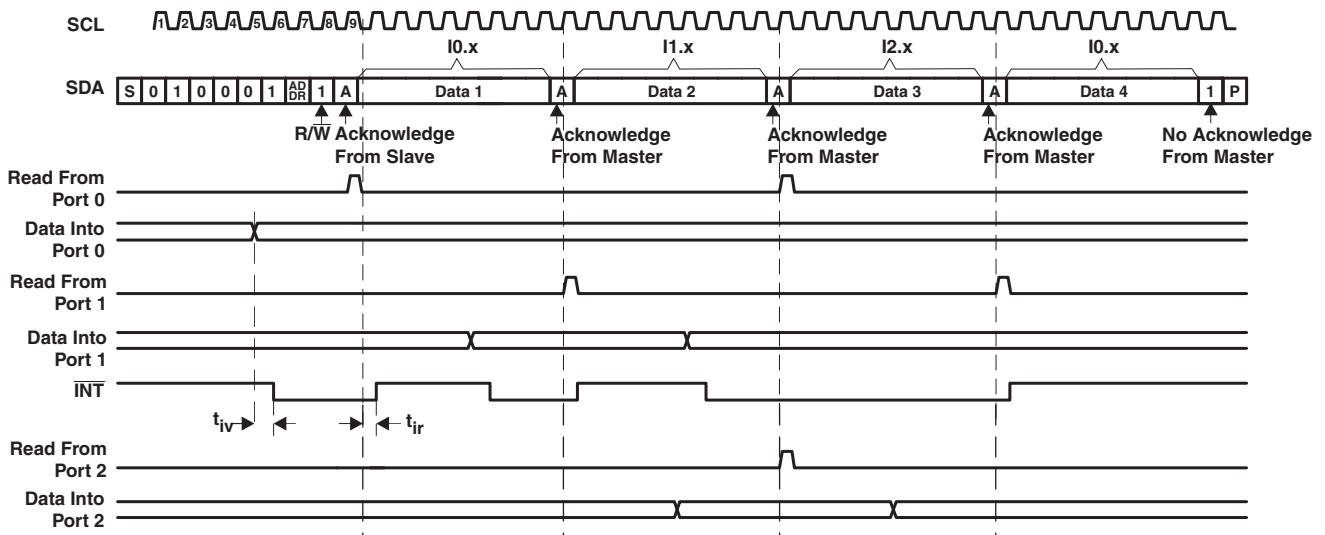

Figure 26. Read From Register



- A. Transfer of data can be stopped at any time by a Stop condition. When this occurs, data present at the latest acknowledge phase is valid (output mode). It is assumed that the command byte previously has been set to 00 (read Input Port register).
- B. This figure eliminates the command byte transfer, a restart, and slave address call between the initial slave address call and actual data transfer from P port (see Figure 26).
- C. Auto-increment mode is enabled.

Figure 27. Read Input Port Register

## 8.5 Register Maps

### 8.5.1 Control Register and Command Byte

Following the successful acknowledgment of the address byte, the bus master sends a command byte, which is stored in the control register in the TCA6424A. Four bits of this data byte state the operation (read or write) and the internal registers (input, output, polarity inversion, or configuration) that will be affected. The control register can be written or read through the I<sup>2</sup>C bus. The command byte is sent only during a write transmission.

The control register includes an Auto-Increment (AI) bit which is the most significant bit (bit 7) of the command byte. At power-up, the control register defaults to 00 (hex), with the AI bit set to logic 1, and the lowest 7 bits set to logic 0.

If AI is 1, the 2 least significant bits are automatically incremented after a read or write. This allows the user to program and/or read the 3 register banks sequentially. If more than 3 bytes of data are written when AI is 1, previous data in the selected registers will be overwritten. Reserved registers are skipped and not accessed (refer to Table 5).

If AI is 0, the 2 least significant bits are not incremented after data is read or written. During a read operation, the same register bank is read each time. During a write operation, data is written to the same register bank each time.

Reserved command codes and command byte outside the range stated in the Command Byte table must not be accessed for proper device functionality.

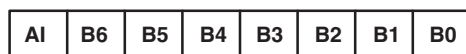

**Figure 28. Control Register Bits**

**Register Maps (continued)**
**Table 4. Command Byte**

CONTROL REGISTER BITS								AUTO-INCREMENT STATE	COMMAND BYTE (HEX)	REGISTER	PROTOCOL	POWER-UP DEFAULT
AI	B6	B5	B4	B3	B2	B1	B0					
0	0	0	0	0	0	0	0	Disable	00	Input Port 0	Read byte	xxxx xxxx <sup>(1)</sup>
1	0	0	0	0	0	0	0	Enable	80			
0	0	0	0	0	0	0	1	Disable	01	Input Port 1	Read byte	xxxx xxxx <sup>(1)</sup>
1	0	0	0	0	0	0	1	Enable	81			
0	0	0	0	0	0	1	0	Disable	02	Input Port 2	Read byte	xxxx xxxx <sup>(1)</sup>
1	0	0	0	0	0	1	0	Enable	82			
0	0	0	0	0	0	1	1	Disable	03	Reserved	Reserved	Reserved
1	0	0	0	0	0	1	1	Enable	83			
0	0	0	0	0	1	0	0	Disable	04	Output Port 0	Read/write byte	1111 1111
1	0	0	0	0	1	0	0	Enable	84			
0	0	0	0	0	1	0	1	Disable	05	Output Port 1	Read/write byte	1111 1111
1	0	0	0	0	1	0	1	Enable	85			
0	0	0	0	0	1	1	0	Disable	06	Output Port 2	Read/write byte	1111 1111
1	0	0	0	0	1	1	0	Enable	86			
0	0	0	0	0	1	1	1	Disable	07	Reserved	Reserved	Reserved
1	0	0	0	0	1	1	1	Enable	87			
0	0	0	0	1	0	0	0	Disable	08	Polarity Inversion Port 0	Read/write byte	0000 0000
1	0	0	0	1	0	0	0	Enable	88			
0	0	0	0	1	0	0	1	Disable	09	Polarity Inversion Port 1	Read/write byte	0000 0000
1	0	0	0	1	0	0	1	Enable	89			
0	0	0	0	1	0	1	0	Disable	0A	Polarity Inversion Port 2	Read/write byte	0000 0000
1	0	0	0	1	0	1	0	Enable	8A			
0	0	0	0	1	0	1	1	Disable	0B	Reserved	Reserved	Reserved
1	0	0	0	1	0	1	1	Enable	8B			
0	0	0	0	1	1	0	0	Disable	0C	Configuration Port 0	Read/write byte	1111 1111
1	0	0	0	1	1	0	0	Enable	8C			
0	0	0	0	1	1	0	1	Disable	0D	Configuration Port 1	Read/write byte	1111 1111
1	0	0	0	1	1	0	1	Enable	8D			
0	0	0	0	1	1	1	0	Disable	0E	Configuration Port 2	Read/write byte	1111 1111
1	0	0	0	1	1	1	0	Enable	8E			
0	0	0	0	1	1	1	1	Disable	0F	Reserved	Reserved	Reserved
1	0	0	0	1	1	1	1	Enable	8F			

(1) Undefined

## 8.5.2 Register Descriptions

The Input Port registers (registers 0, 1 and 2) reflect the incoming logic levels of the pins, regardless of whether the pin is defined as an input or an output by the Configuration register. They act only on read operation. Writes to these registers have no effect. The default value (X) is determined by the externally applied logic level. Before a read operation, a write transmission is sent with the command byte to indicate to the I<sup>2</sup>C device that the Input Port register will be accessed next.

**Table 5. Registers 0, 1 and 2 (Input Port Registers)**

<b>BIT</b>	I-07	I-06	I-05	I-04	I-03	I-02	I-01	I-00
<b>DEFAULT</b>	X	X	X	X	X	X	X	X
<b>BIT</b>	I-17	I-16	I-15	I-14	I-13	I-12	I-11	I-10
<b>DEFAULT</b>	X	X	X	X	X	X	X	X
<b>BIT</b>	I-27	I-26	I-25	I-24	I-23	I-22	I-21	I-20
<b>DEFAULT</b>	X	X	X	X	X	X	X	X

The Output Port registers (registers 4, 5 and 6) shows the outgoing logic levels of the pins defined as outputs by the Configuration register. Bit values in these registers have no effect on pins defined as inputs. In turn, reads from these registers reflect the value that is in the flip-flop controlling the output selection, NOT the actual pin value.

**Table 6. Registers 4, 5 and 6 (Output Port Registers)**

<b>BIT</b>	O-07	O-06	O-05	O-04	O-03	O-02	O-01	O-00
<b>DEFAULT</b>	1	1	1	1	1	1	1	1
<b>BIT</b>	O-17	O-16	O-15	O-14	O-13	O-12	O-11	O-10
<b>DEFAULT</b>	1	1	1	1	1	1	1	1
<b>BIT</b>	O-27	O-26	O-25	O-24	O-23	O-22	O-21	O-20
<b>DEFAULT</b>	1	1	1	1	1	1	1	1

The Polarity Inversion registers (registers 8, 9 and 10) allow polarity inversion of pins defined as inputs by the Configuration register. If a bit in these registers is set (written with 1), the corresponding port pin's polarity is inverted. If a bit in these registers is cleared (written with a 0), the corresponding port pin's original polarity is retained.

**Table 7. Registers 8, 9 and 10 (Polarity Inversion Registers)**

<b>BIT</b>	P-07	P-06	P-05	P-04	P-03	P-02	P-01	P-00
<b>DEFAULT</b>	0	0	0	0	0	0	0	0
<b>BIT</b>	P-17	P-16	P-15	P-14	P-13	P-12	P-11	P-10
<b>DEFAULT</b>	0	0	0	0	0	0	0	0
<b>BIT</b>	P-27	P-26	P-25	P-24	P-23	P-22	P-21	P-20
<b>DEFAULT</b>	0	0	0	0	0	0	0	0

The Configuration registers (registers 12, 13 and 14) configure the direction of the I/O pins. If a bit in these registers is set to 1, the corresponding port pin is enabled as an input with a high-impedance output driver. If a bit in these registers is cleared to 0, the corresponding port pin is enabled as an output.

**Table 8. Registers 12, 13 and 14 (Configuration Registers)**

<b>BIT</b>	C-07	C-06	C-05	C-04	C-03	C-02	C-01	C-00
<b>DEFAULT</b>	1	1	1	1	1	1	1	1
<b>BIT</b>	C-17	C-16	C-15	C-14	C-13	C-12	C-11	C-10
<b>DEFAULT</b>	1	1	1	1	1	1	1	1
<b>BIT</b>	C-27	C-26	C-25	C-24	C-23	C-22	C-21	C-20
<b>DEFAULT</b>	1	1	1	1	1	1	1	1

## 9 Applications and Implementation

### 9.1 Typical Application

Figure 29 shows an application in which the TCA6424A can be used.

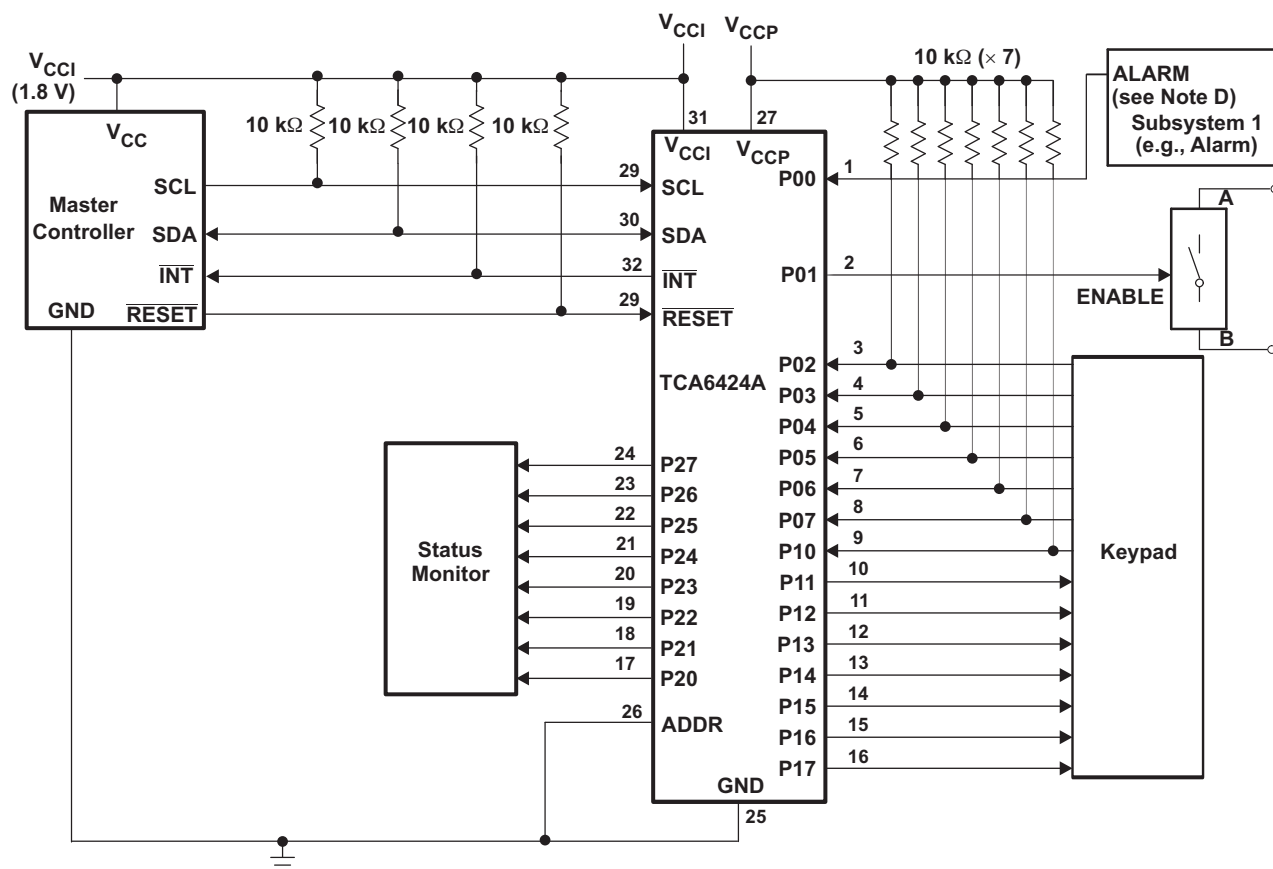

- Device address configured as 0100000 for this example.
- P00 and P02–P10 are configured as inputs.
- P01, P11–P17, and P20–P27 are configured as outputs.
- Resistors are required for inputs (on P port) that may float. If a driver to an input will not let the input float, a resistor is not needed. Outputs (in the P port) do not need pullup resistors.

Figure 29. Typical Application

## Typical Application (continued)

### 9.1.1 Minimizing $I_{CC}$ When I/Os Control LEDs

When the I/Os are used to control LEDs, normally they are connected to  $V_{CC}$  through a resistor as shown in Figure 29. The LED acts as a diode so, when the LED is off, the I/O  $V_{IN}$  is about 1.2 V less than  $V_{CC}$ . The  $\Delta I_{CC}$  parameter in Electrical Characteristics shows how  $I_{CC}$  increases as  $V_{IN}$  becomes lower than  $V_{CC}$ . Designs that must minimize current consumption, such as battery power applications, should consider maintaining the I/O pins greater than or equal to  $V_{CC}$  when the LED is off.

Figure 30 shows a high-value resistor in parallel with the LED. Figure 31 shows  $V_{CC}$  less than the LED supply voltage by at least 1.2 V. Both of these methods maintain the I/O  $V_{IN}$  at or above  $V_{CC}$  and prevent additional supply current consumption when the LED is off.

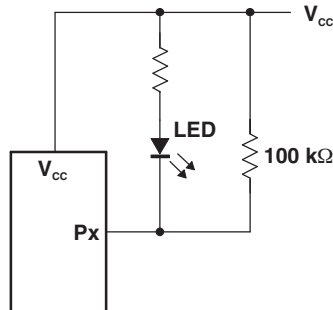

**Figure 30. High-Value Resistor in Parallel With the LED**

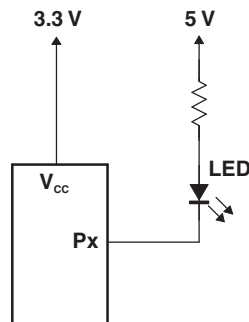

**Figure 31. Device Supplied by a Low Voltage**

## 10 Power Supply Recommendation

In the event of a glitch or data corruption, TCA6424A can be reset to its default conditions by using the power-on reset feature. Power-on reset requires that the device go through a power cycle to be completely reset. This reset also happens when the device is powered on for the first time in an application.

The two types of power-on reset are shown in Figure 32 and Figure 33.

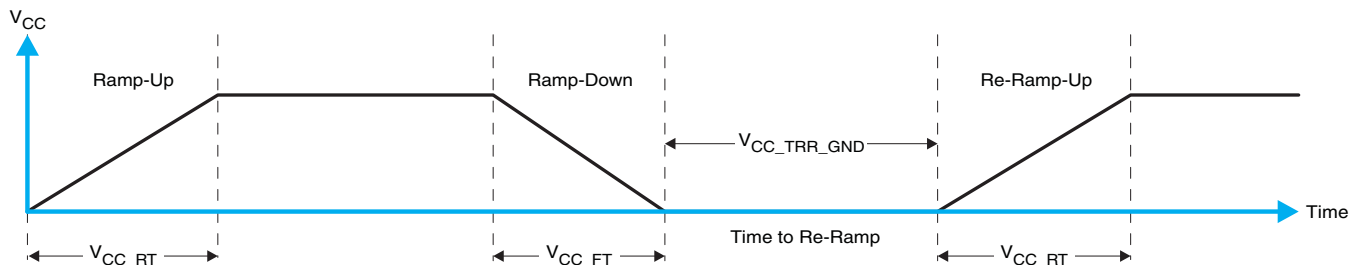

Figure 32.  $V_{CC}$  is Lowered Below 0.2 V or 0 V and Then Ramped Up to  $V_{CC}$

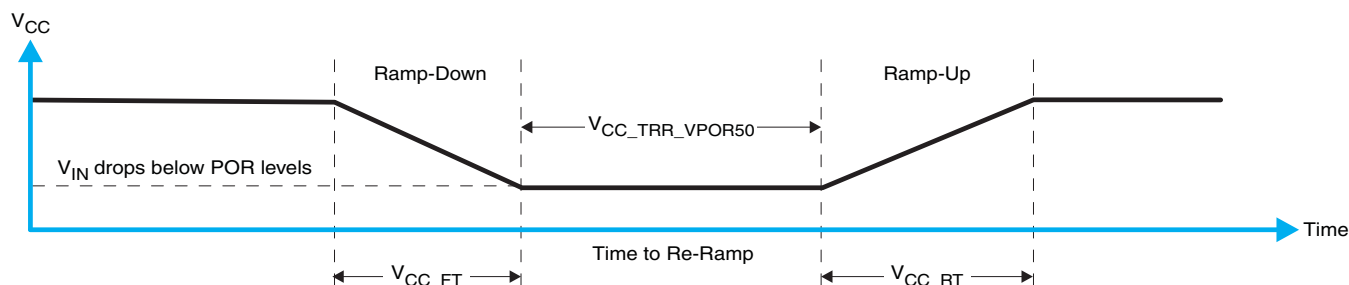

Figure 33.  $V_{CC}$  is Lowered Below the POR Threshold, Then Ramped Back Up to  $V_{CC}$

Table 9 specifies the performance of the power-on reset feature for TCA6424A for both types of power-on reset.

Table 9. Recommended Supply Sequencing and Rates<sup>(1)</sup>

PARAMETER			MIN	TYP	MAX	UNIT
$t_{VCC\_FT}$	Fall rate	See Figure 32	1		100	ms
$t_{VCC\_RT}$	Rise rate	See Figure 32	0.01		100	ms
$t_{VCC\_TRR\_GND}$	Time to re-ramp (when $V_{CC}$ drops to GND)	See Figure 32	40			$\mu$ s
$t_{VCC\_TRR\_POR50}$	Time to re-ramp (when $V_{CC}$ drops to $V_{POR\_MIN} - 50$ mV)	See Figure 33	40			$\mu$ s
$V_{CC\_GH}$	Level that $V_{CCP}$ can glitch down to, but not cause a functional disruption when $V_{CCX\_GW} = 1$ $\mu$ s	See Figure 34			1.2	V
$t_{VCC\_GW}$	Glitch width that will not cause a functional disruption when $V_{CCX\_GH} = 0.5 \times V_{CCX}$	See Figure 34			10	$\mu$ s
$V_{PORF}$	Voltage trip point of POR on falling $V_{CC}$		0.767		1.144	V
$V_{PORR}$	Voltage trip point of POR on rising $V_{CC}$		1.033		1.428	V

(1)  $T_A = -40^\circ\text{C}$  to  $85^\circ\text{C}$  (unless otherwise noted)

Glitches in the power supply can also affect the power-on reset performance of this device. The glitch width ( $V_{CC\_GW}$ ) and height ( $V_{CC\_GH}$ ) are dependent on each other. The bypass capacitance, source impedance, and device impedance are factors that affect power-on reset performance. Figure 34 and Table 9 provide more information on how to measure these specifications.

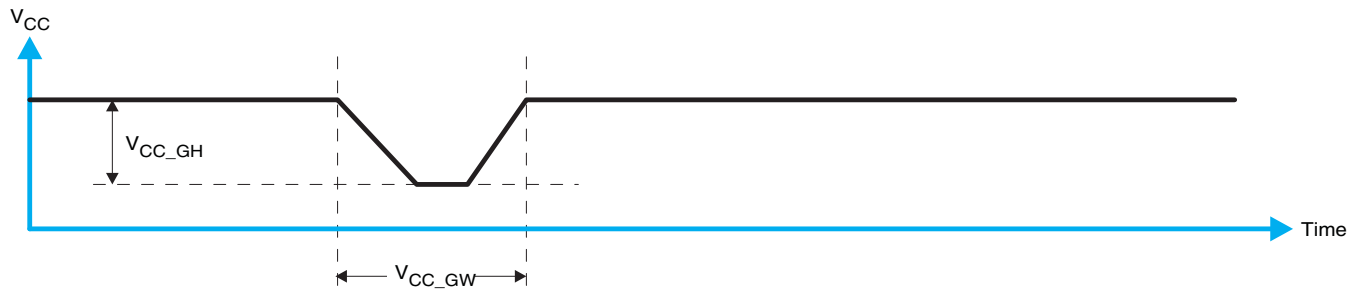

Figure 34. Glitch Width and Glitch Height

$V_{POR}$  is critical to the power-on reset.  $V_{POR}$  is the voltage level at which the reset condition is released and all the registers and the I<sup>2</sup>C/SMBus state machine are initialized to their default states. The value of  $V_{POR}$  differs based on the  $V_{CC}$  being lowered to or from 0. Figure 35 and Table 9 provide more details on this specification.

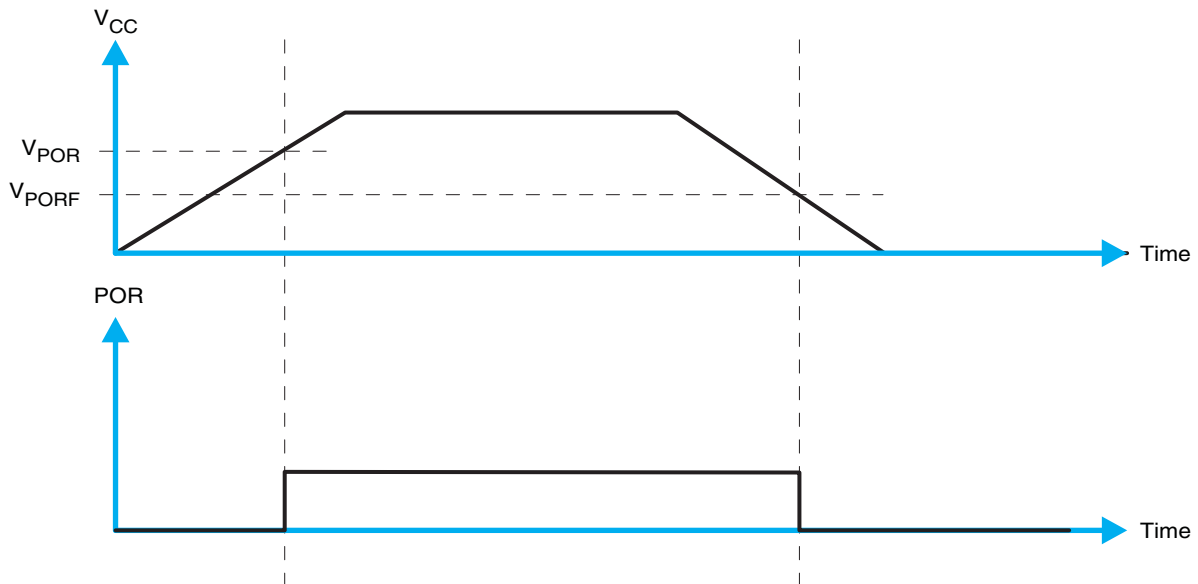

Figure 35.  $V_{POR}$

## 11 器件和文档支持

### 11.1 Trademarks

All trademarks are the property of their respective owners.

### 11.2 Electrostatic Discharge Caution



This integrated circuit can be damaged by ESD. Texas Instruments recommends that all integrated circuits be handled with appropriate precautions. Failure to observe proper handling and installation procedures can cause damage.

ESD damage can range from subtle performance degradation to complete device failure. Precision integrated circuits may be more susceptible to damage because very small parametric changes could cause the device not to meet its published specifications.

### 11.3 Glossary

[SLYZ022](#) — *TI Glossary*.

This glossary lists and explains terms, acronyms and definitions.

## 12 机械封装和可订购信息

以下页中包括机械封装和可订购信息。 这些信息是针对指定器件可提供的最新数据。 这些数据会在无通知且不对本文档进行修订的情况下发生改变。 欲获得该数据表的浏览器版本，请查阅左侧的导航栏。

## 重要声明

德州仪器(TI)及其下属子公司有权根据 JESD46 最新标准,对所提供的产品和服务进行更正、修改、增强、改进或其它更改,并有权根据 JESD48 最新标准中止提供任何产品和服务。客户在下订单前应获取最新的相关信息,并验证这些信息是否完整且是最新的。所有产品的销售都遵循在订单确认时所提供的TI 销售条款与条件。

TI 保证其所销售的组件的性能符合产品销售时 TI 半导体产品销售条件与条款的适用规范。仅在 TI 保证的范围内,且 TI 认为有必要时才会使用测试或其它质量控制技术。除非适用法律做出了硬性规定,否则没有必要对每种组件的所有参数进行测试。

TI 对应用帮助或客户产品设计不承担任何义务。客户应对其使用 TI 组件的产品和应用自行负责。为尽量减小与客户产品和应用相关的风险,客户应提供充分的设计与操作安全措施。

TI 不对任何 TI 专利权、版权、屏蔽作品权或其它与使用了 TI 组件或服务的组合设备、机器或流程相关的 TI 知识产权中授予的直接或隐含权限作出任何保证或解释。TI 所发布的与第三方产品或服务有关的信息,不能构成从 TI 获得使用这些产品或服务的许可、授权、或认可。使用此类信息可能需要获得第三方的专利权或其它知识产权方面的许可,或是 TI 的专利权或其它知识产权方面的许可。

对于 TI 的产品手册或数据表中 TI 信息的重要部分,仅在没有对内容进行任何篡改且带有相关授权、条件、限制和声明的情况下才允许进行复制。TI 对此类篡改过的文件不承担任何责任或义务。复制第三方的信息可能需要服从额外的限制条件。

在转售 TI 组件或服务时,如果对该组件或服务参数的陈述与 TI 标明的参数相比存在差异或虚假成分,则会失去相关 TI 组件或服务的所有明示或暗示授权,且这是不正当的、欺诈性商业行为。TI 对任何此类虚假陈述均不承担任何责任或义务。

客户认可并同意,尽管任何应用相关信息或支持仍可能由 TI 提供,但他们将独立负责满足与其产品及其在应用中使用的 TI 产品相关的所有法律、法规和安全相关要求。客户声明并同意,他们具备制定与实施安全措施所需的全部专业技术和知识,可预见故障的危险后果、监测故障及其后果、降低有可能造成人身伤害的故障的发生机率并采取适当的补救措施。客户将全额赔偿因在此类安全关键应用中使用任何 TI 组件而对 TI 及其代理造成的任何损失。

在某些场合中,为了推进安全相关应用有可能对 TI 组件进行特别的促销。TI 的目标是利用此类组件帮助客户设计和创立其特有的可满足适用的功能安全性标准和要求的终端产品解决方案。尽管如此,此类组件仍然服从这些条款。

TI 组件未获得用于 FDA Class III (或类似的生命攸关医疗设备)的授权许可,除非各方授权官员已经达成了专门管控此类使用的特别协议。

只有那些 TI 特别注明属于军用等级或“增强型塑料”的 TI 组件才是设计或专门用于军事/航空应用或环境的。购买者认可并同意,对并非指定面向军事或航空航天用途的 TI 组件进行军事或航空航天方面的应用,其风险由客户单独承担,并且由客户独立负责满足与此类使用相关的所有法律和法规要求。

TI 已明确指定符合 ISO/TS16949 要求的产品,这些产品主要用于汽车。在任何情况下,因使用非指定产品而无法达到 ISO/TS16949 要求, TI 不承担任何责任。

	产品		应用
数字音频	<a href="http://www.ti.com.cn/audio">www.ti.com.cn/audio</a>	通信与电信	<a href="http://www.ti.com.cn/telecom">www.ti.com.cn/telecom</a>
放大器和线性器件	<a href="http://www.ti.com.cn/amplifiers">www.ti.com.cn/amplifiers</a>	计算机及周边	<a href="http://www.ti.com.cn/computer">www.ti.com.cn/computer</a>
数据转换器	<a href="http://www.ti.com.cn/dataconverters">www.ti.com.cn/dataconverters</a>	消费电子	<a href="http://www.ti.com.cn/consumer-apps">www.ti.com.cn/consumer-apps</a>
DLP® 产品	<a href="http://www.dlp.com">www.dlp.com</a>	能源	<a href="http://www.ti.com.cn/energy">www.ti.com.cn/energy</a>
DSP - 数字信号处理器	<a href="http://www.ti.com.cn/dsp">www.ti.com.cn/dsp</a>	工业应用	<a href="http://www.ti.com.cn/industrial">www.ti.com.cn/industrial</a>
时钟和计时器	<a href="http://www.ti.com.cn/clockandtimers">www.ti.com.cn/clockandtimers</a>	医疗电子	<a href="http://www.ti.com.cn/medical">www.ti.com.cn/medical</a>
接口	<a href="http://www.ti.com.cn/interface">www.ti.com.cn/interface</a>	安防应用	<a href="http://www.ti.com.cn/security">www.ti.com.cn/security</a>
逻辑	<a href="http://www.ti.com.cn/logic">www.ti.com.cn/logic</a>	汽车电子	<a href="http://www.ti.com.cn/automotive">www.ti.com.cn/automotive</a>
电源管理	<a href="http://www.ti.com.cn/power">www.ti.com.cn/power</a>	视频和影像	<a href="http://www.ti.com.cn/video">www.ti.com.cn/video</a>
微控制器 (MCU)	<a href="http://www.ti.com.cn/microcontrollers">www.ti.com.cn/microcontrollers</a>		
RFID 系统	<a href="http://www.ti.com.cn/rfidsys">www.ti.com.cn/rfidsys</a>		
OMAP应用处理器	<a href="http://www.ti.com.cn/omap">www.ti.com.cn/omap</a>		
无线连通性	<a href="http://www.ti.com.cn/wirelessconnectivity">www.ti.com.cn/wirelessconnectivity</a>	德州仪器在线技术支持社区	<a href="http://www.deyisupport.com">www.deyisupport.com</a>

邮寄地址: 上海市浦东新区世纪大道1568号, 中建大厦32楼邮政编码: 200122  
Copyright © 2014, 德州仪器半导体技术(上海)有限公司

**PACKAGING INFORMATION**

Orderable Device	Status (1)	Package Type	Package Drawing	Pins	Package Qty	Eco Plan (2)	Lead finish/ Ball material (6)	MSL Peak Temp (3)	Op Temp (°C)	Device Marking (4/5)	Samples
TCA6424ARGJR	ACTIVE	UQFN	RGJ	32	3000	RoHS & Green	NIPDAU	Level-1-260C-UNLIM	-40 to 85	PH424A	Samples

(1) The marketing status values are defined as follows:

**ACTIVE:** Product device recommended for new designs.

**LIFEBUY:** TI has announced that the device will be discontinued, and a lifetime-buy period is in effect.

**NRND:** Not recommended for new designs. Device is in production to support existing customers, but TI does not recommend using this part in a new design.

**PREVIEW:** Device has been announced but is not in production. Samples may or may not be available.

**OBSOLETE:** TI has discontinued the production of the device.

(2) **RoHS:** TI defines "RoHS" to mean semiconductor products that are compliant with the current EU RoHS requirements for all 10 RoHS substances, including the requirement that RoHS substance do not exceed 0.1% by weight in homogeneous materials. Where designed to be soldered at high temperatures, "RoHS" products are suitable for use in specified lead-free processes. TI may reference these types of products as "Pb-Free".

**RoHS Exempt:** TI defines "RoHS Exempt" to mean products that contain lead but are compliant with EU RoHS pursuant to a specific EU RoHS exemption.

**Green:** TI defines "Green" to mean the content of Chlorine (Cl) and Bromine (Br) based flame retardants meet JS709B low halogen requirements of <=1000ppm threshold. Antimony trioxide based flame retardants must also meet the <=1000ppm threshold requirement.

(3) MSL, Peak Temp. - The Moisture Sensitivity Level rating according to the JEDEC industry standard classifications, and peak solder temperature.

(4) There may be additional marking, which relates to the logo, the lot trace code information, or the environmental category on the device.

(5) Multiple Device Markings will be inside parentheses. Only one Device Marking contained in parentheses and separated by a "-" will appear on a device. If a line is indented then it is a continuation of the previous line and the two combined represent the entire Device Marking for that device.

(6) Lead finish/Ball material - Orderable Devices may have multiple material finish options. Finish options are separated by a vertical ruled line. Lead finish/Ball material values may wrap to two lines if the finish value exceeds the maximum column width.

**Important Information and Disclaimer:**The information provided on this page represents TI's knowledge and belief as of the date that it is provided. TI bases its knowledge and belief on information provided by third parties, and makes no representation or warranty as to the accuracy of such information. Efforts are underway to better integrate information from third parties. TI has taken and continues to take reasonable steps to provide representative and accurate information but may not have conducted destructive testing or chemical analysis on incoming materials and chemicals. TI and TI suppliers consider certain information to be proprietary, and thus CAS numbers and other limited information may not be available for release.

In no event shall TI's liability arising out of such information exceed the total purchase price of the TI part(s) at issue in this document sold by TI to Customer on an annual basis.

## TAPE AND REEL INFORMATION



### QUADRANT ASSIGNMENTS FOR PIN 1 ORIENTATION IN TAPE



\*All dimensions are nominal

Device	Package Type	Package Drawing	Pins	SPQ	Reel Diameter (mm)	Reel Width W1 (mm)	A0 (mm)	B0 (mm)	K0 (mm)	P1 (mm)	W (mm)	Pin1 Quadrant
TCA6424ARGJR	UQFN	RGJ	32	3000	330.0	12.4	5.3	5.3	0.75	8.0	12.0	Q2

TAPE AND REEL BOX DIMENSIONS

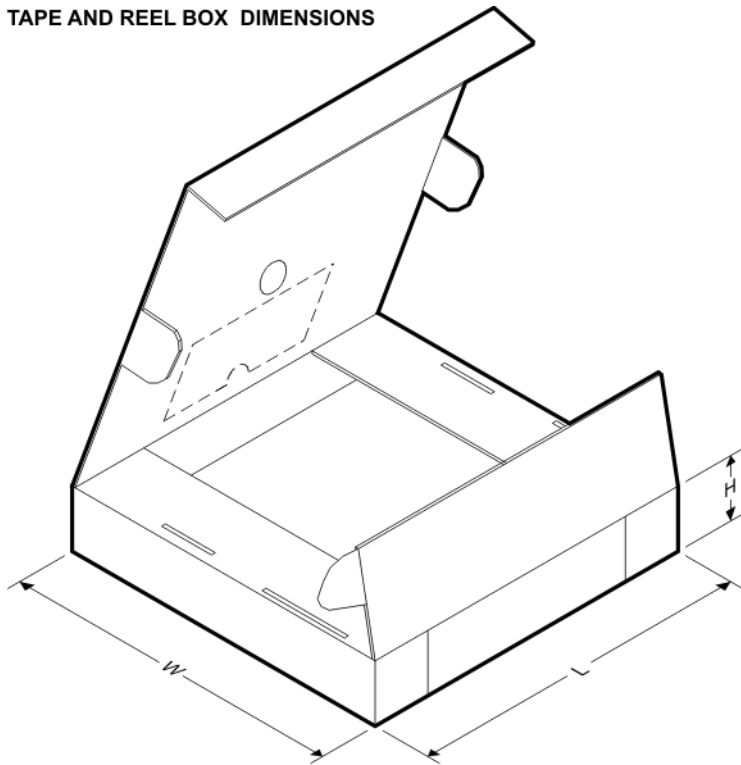

\*All dimensions are nominal

Device	Package Type	Package Drawing	Pins	SPQ	Length (mm)	Width (mm)	Height (mm)
TCA6424ARGJR	UQFN	RGJ	32	3000	346.0	346.0	35.0

RGJ0032A

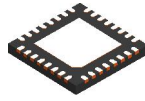

PACKAGE OUTLINE

UQFN - 0.6 mm max height

PLASTIC QUAD FLATPACK - NO LEAD

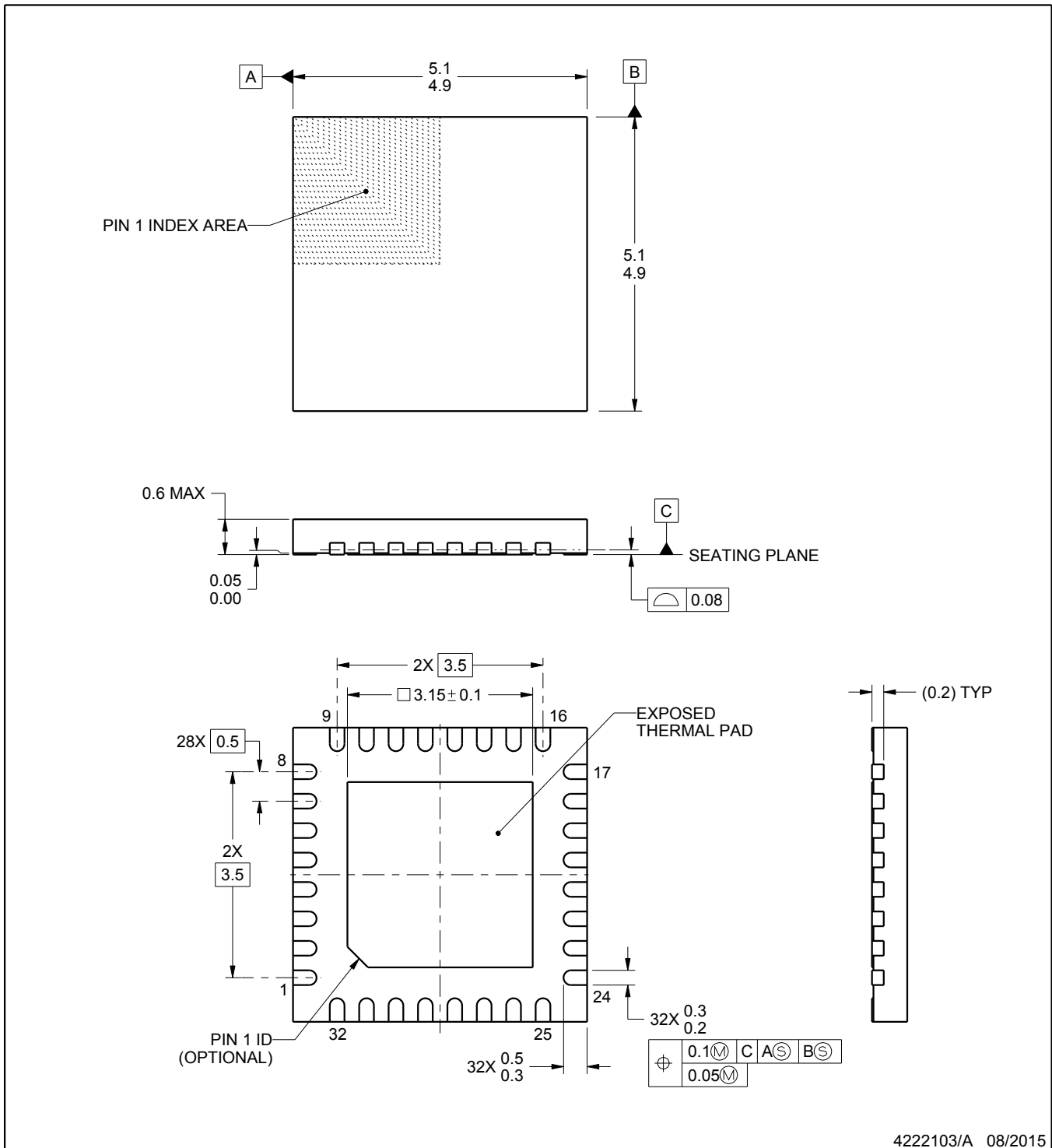

4222103/A 08/2015

NOTES:

1. All linear dimensions are in millimeters. Any dimensions in parenthesis are for reference only. Dimensioning and tolerancing per ASME Y14.5M.
2. This drawing is subject to change without notice.
3. The package thermal pad must be soldered to the printed circuit board for thermal and mechanical performance.

# EXAMPLE BOARD LAYOUT

RGJ0032A

UQFN - 0.6 mm max height

PLASTIC QUAD FLATPACK - NO LEAD

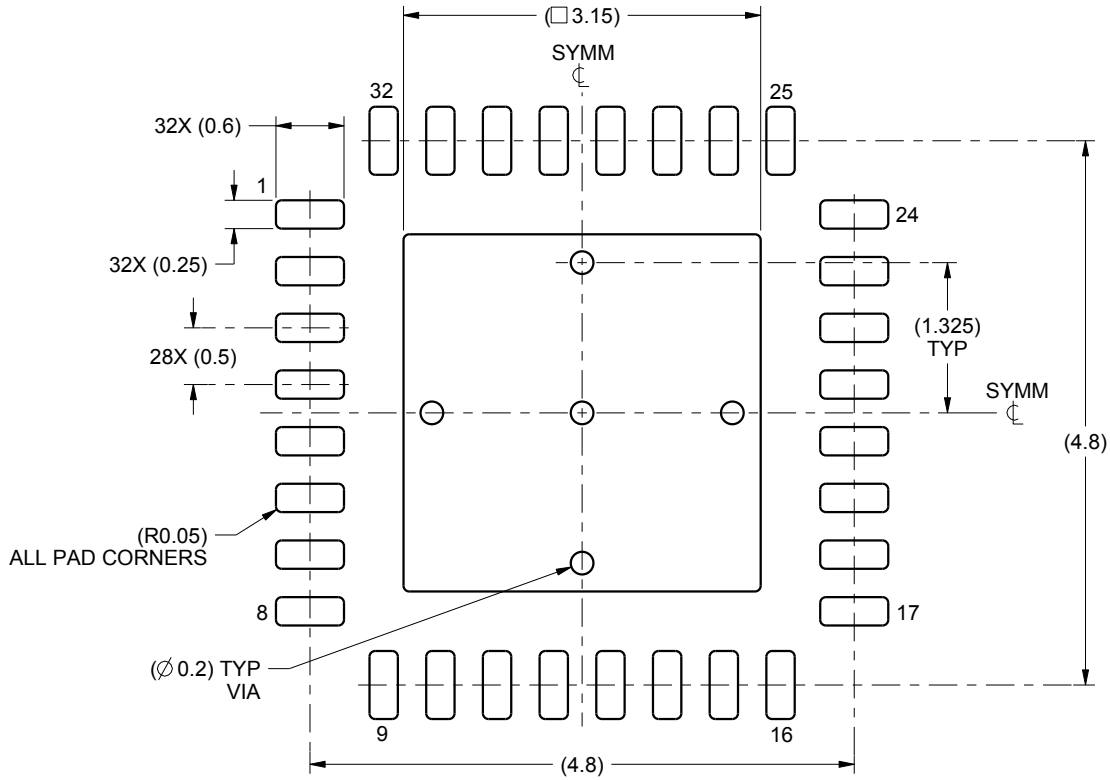

LAND PATTERN EXAMPLE  
SCALE:15X

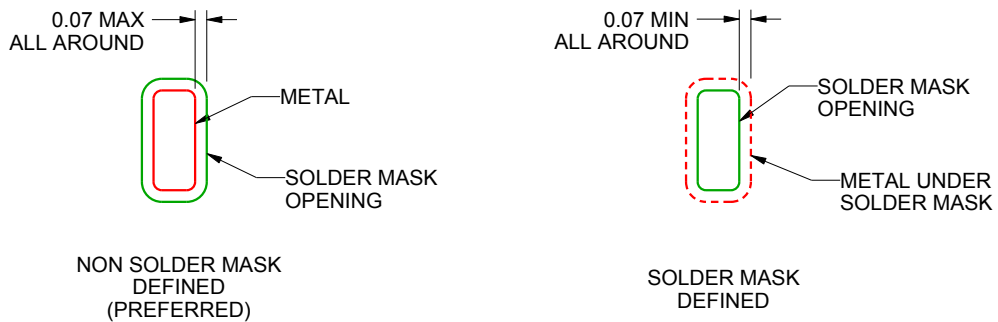

SOLDER MASK DETAILS

4222103/A 08/2015

NOTES: (continued)

- This package is designed to be soldered to a thermal pad on the board. For more information, see Texas Instruments literature number SLUA271 ([www.ti.com/lit/slua271](http://www.ti.com/lit/slua271)).

# EXAMPLE STENCIL DESIGN

RGJ0032A

UQFN - 0.6 mm max height

PLASTIC QUAD FLATPACK - NO LEAD

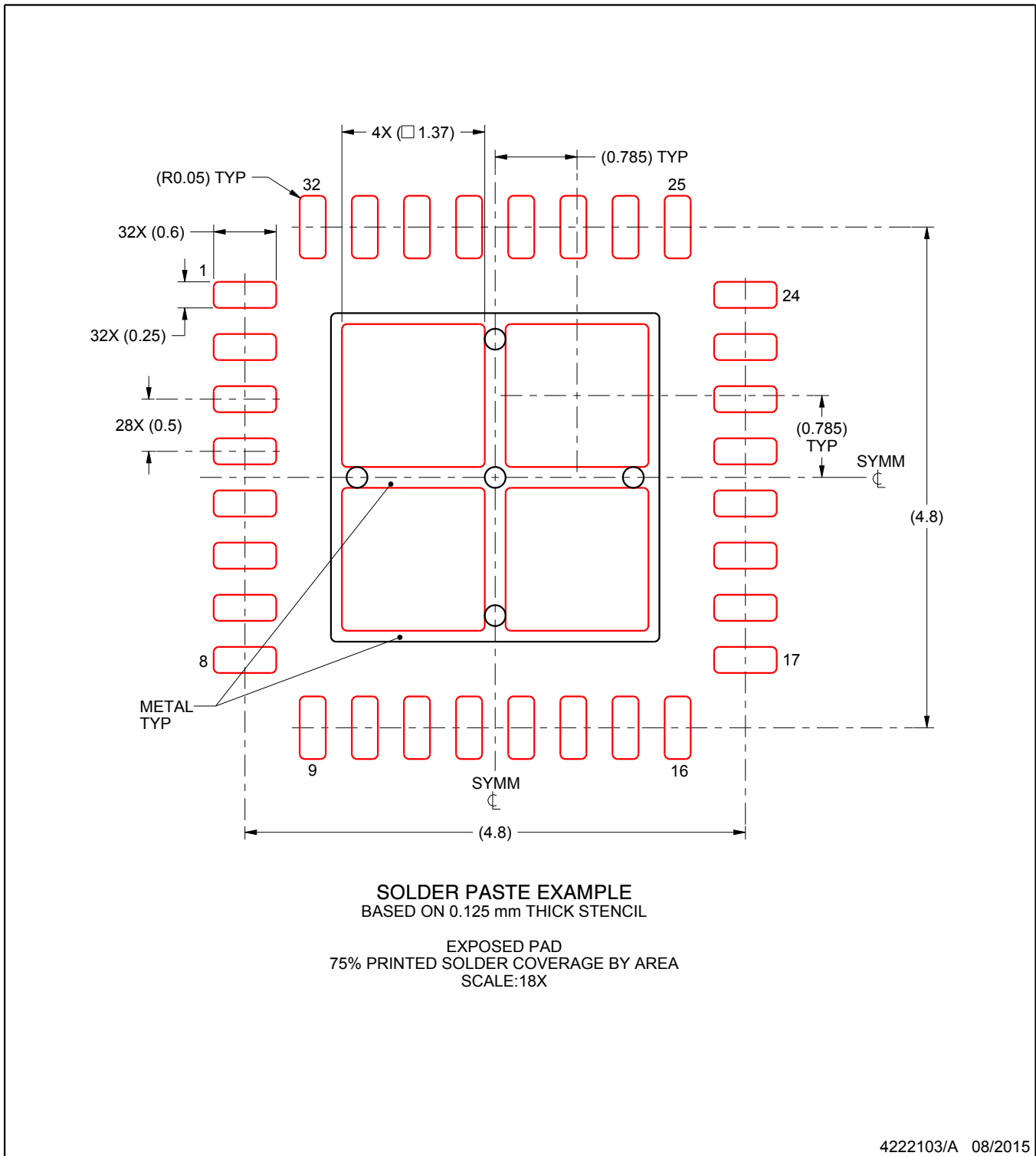

NOTES: (continued)

5. Laser cutting apertures with trapezoidal walls and rounded corners may offer better paste release. IPC-7525 may have alternate design recommendations.

## 重要声明和免责声明

TI 均以“原样”提供技术性及其可靠性数据（包括数据表）、设计资源（包括参考设计）、应用或其他设计建议、网络工具、安全信息和其他资源，不保证其中不含任何瑕疵，且不做任何明示或暗示的担保，包括但不限于对适销性、适合某特定用途或不侵犯任何第三方知识产权的暗示担保。

所述资源可供专业开发人员应用TI 产品进行设计使用。您将对以下行为独自承担全部责任：(1) 针对您的应用选择合适的TI 产品；(2) 设计、验证并测试您的应用；(3) 确保您的应用满足相应标准以及任何其他安全、安保或其他要求。所述资源如有变更，恕不另行通知。TI 对您使用所述资源的授权仅限于开发资源所涉及TI 产品的相关应用。除此之外不得复制或展示所述资源，也不提供其它TI 或任何第三方的知识产权授权许可。如因使用所述资源而产生任何索赔、赔偿、成本、损失及债务等，TI 对此概不负责，并且您须赔偿由此对TI 及其代表造成的损害。

TI 所提供产品均受TI 的销售条款 (<http://www.ti.com.cn/zh-cn/legal/termsofsale.html>) 以及ti.com.cn上或随附TI产品提供的其他可适用条款的约束。TI提供所述资源并不扩展或以其他方式更改TI 针对TI 产品所发布的可适用的担保范围或担保免责声明。

邮寄地址：上海市浦东新区世纪大道 1568 号中建大厦 32 楼，邮政编码：200122  
Copyright © 2020 德州仪器半导体技术（上海）有限公司