

THVD14xx 3.3-V to 5-V RS-485 Transceivers with ± 18 -kV IEC ESD Protection

1 Features

- Meets or Exceeds the Requirements of the TIA/EIA-485A Standard
- 3 V to 5.5 V Supply Voltage
- Differential Output Exceeds 2.1 V for PROFIBUS Compatibility with 5-V Supply
- Bus I/O ESD Protection
 - ± 30 kV HBM
 - ± 18 kV IEC 61000-4-2 Contact Discharge
 - ± 25 kV IEC 61000-4-2 Air-Gap Discharge
 - ± 4 kV IEC 61000-4-4 Fast Transient Burst
- Extended Operational Common-mode Range: ± 15 V
- Low EMI 500 kbps and 50 Mbps Data Rates
- Large Receiver Hysteresis for Noise Rejection
- Low Power Consumption
 - Standby Supply Current: $< 1 \mu\text{A}$
 - Current During Operation: $< 3 \text{ mA}$
- Extended Ambient Temperature Range: -40°C to 125°C
- Glitch-Free Power-Up/Down for Hot Plug-in Capability
- Open, Short, and Idle Bus Failsafe
- 1/8 Unit Load (Up to 256 Bus Nodes)
- Small-Size VSON and VSSOP Packages Save Board Space or SOIC for Drop-in Compatibility

2 Applications

- Motor Drives
- Factory Automation & Control
- Grid Infrastructure
- Building Automation
- HVAC Systems
- Video Surveillance
- Process Analytics
- Wireless Infrastructure

3 Description

THVD14xx is a family of noise-immune RS-485/RS-422 transceivers designed to operate in rugged industrial environments. The bus pins of these devices are robust to high levels of IEC electrical fast transients (EFT) and IEC electrostatic discharge (ESD) events, eliminating the need for additional system level protection components.

Each of these devices operates from a single supply between 3 V and 5.5 V. The devices in this family feature an extended common-mode voltage range which makes them suitable for multi-point applications over long cable runs.

THVD14xx family of devices is available in small VSON and VSSOP packages for space constrained applications. These devices are characterized over ambient free-air temperatures from -40°C to 125°C .

Device Information⁽¹⁾

PART NUMBER	PACKAGE	BODY SIZE (NOM)
THVD1410	VSSOP (8)	3.00 mm x 3.00 mm
	SOIC (8)	4.90 mm x 3.91 mm
THVD1450	VSON (8)	3.00 mm x 3.00 mm
	VSSOP (8)	3.00 mm x 3.00 mm
	SOIC (8)	4.90 mm x 3.91 mm
THVD1451	VSON (8)	3.00 mm x 3.00 mm
	SOIC (8)	4.90 mm x 3.91 mm
THVD1452	VSSOP (10)	3.00 mm x 3.00 mm
	SOIC (14)	8.65 mm x 3.91 mm

(1) For all available packages, see the orderable addendum at the end of the data sheet.

THVD1410 and THVD1450 Simplified Schematic

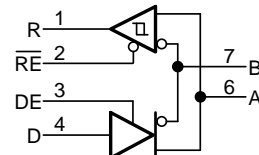

THVD1451 Simplified Schematic

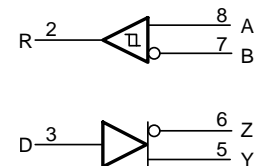

THVD1452 Simplified Schematic

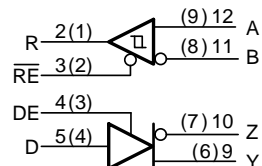

Table of Contents

1 Features	1	9.1 Overview	18
2 Applications	1	9.2 Functional Block Diagrams	18
3 Description	1	9.3 Feature Description	19
4 Revision History	2	9.4 Device Functional Modes	19
5 Device Comparison Table	4	10 Application and Implementation	22
6 Pin Configuration and Functions	5	10.1 Application Information	22
7 Specifications	8	10.2 Typical Application	22
7.1 Absolute Maximum Ratings	8	11 Power Supply Recommendations	28
7.2 ESD Ratings	8	12 Layout	29
7.3 ESD Ratings [IEC]	8	12.1 Layout Guidelines	29
7.4 Recommended Operating Conditions	9	12.2 Layout Example	29
7.5 Thermal Information	9	13 Device and Documentation Support	30
7.6 Power Dissipation	9	13.1 Device Support	30
7.7 Electrical Characteristics	10	13.2 Third-Party Products Disclaimer	30
7.8 Switching Characteristics	11	13.3 Related Links	30
7.9 Typical Characteristics: All Devices	12	13.4 Receiving Notification of Documentation Updates	30
7.10 Typical Characteristics: THD1450, THVD1451 and THVD1452	14	13.5 Community Resources	30
7.11 Typical Characteristics: THVD1410	15	13.6 Trademarks	30
8 Parameter Measurement Information	16	13.7 Electrostatic Discharge Caution	30
9 Detailed Description	18	13.8 Glossary	30
		14 Mechanical, Packaging, and Orderable Information	31

4 Revision History

Changes from Revision D (March 2019) to Revision E	Page
• Changed THVD1451 From: <i>Product Preview</i> To: <i>Production data</i>	1

Changes from Revision C (February 2019) to Revision D	Page
• Changed THVD1410 From: <i>Product Preview</i> To: <i>Production data</i>	1

Changes from Revision B (December 2018) to Revision C	Page
• Changed THVD1452 From: <i>Product Preview</i> To: <i>Production data</i>	1

Changes from Revision A (May 2018) to Revision B	Page
• Added <i>Feature</i> : "Differential Output Exceeds 2.1 V..."	1
• Changed <i>Feature</i> : ± 18 kV IEC 61000-4-2 Air-Gap Discharge To: ± 25 kV IEC 61000-4-2 Air-Gap Discharge	1
• Added SOIC (8) package to THVD1451	1
• Added Thermal Pad to the THVD1450 DRB package	5
• Added Thermal Pad to the THVD1451 DRB package	6
• Changed all pins HBM ESD rating from 4 kV to 8 kV	8
• Changed IEC ESD air-gap discharge rating from 18 kV to 25 kV	8
• Changed THVD1410 power dissipation numbers	9
• Changed THVD1410 driver t_r , t_f TYP from 400 ns to 460 ns and MAX from 600 ns to 680 ns	11
• Changed THVD1410 receiver t_r , t_f TYP from 13 ns to 10 ns	11
• Changed THVD1410 receiver t_{PHL} , t_{PLH} TYP from 60 ns to 35 ns	11
• Added Typical Characteristics, THD1450D	14

- Added condition to [Figure 8](#) to [Figure 3](#) 14
- Added Typical Characteristics, THD1410..... 15
- Changed A to A/Y and B to B/Z in [Figure 20](#) to [Figure 24](#)..... 16
- Added 3rd paragraph to the *Overview* section 18

Changes from Original (November 2017) to Revision A **Page**

- Changed the document status From: *Advanced Information* To: *Production Mix* data 1

5 Device Comparison Table

PART NUMBER	DUPLEX	ENABLES	SIGNALING RATE	NODES
THVD1410	Half	DE, \overline{RE}	up to 500 kbps	256
THVD1450	Half	DE, \overline{RE}	up to 50 Mbps	
THVD1451	Full	None		
THVD1452	Full	DE, \overline{RE}		

6 Pin Configuration and Functions

**THVD1410, THVD1450 Devices
8-Pin D Package (SOIC)
Top View**

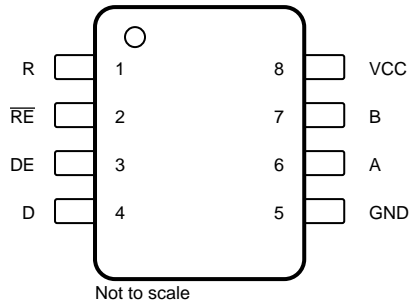

**THVD1410, THVD1450 Devices
8-Pin DGK Package (VSSOP)
Top View**

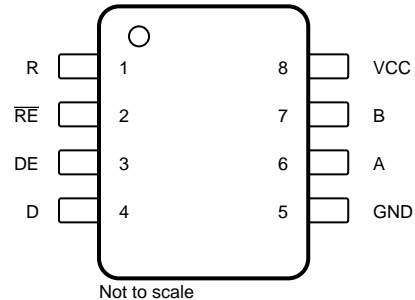

**THVD1450 Device
8-Pin DRB Package (VSON)
Top View**

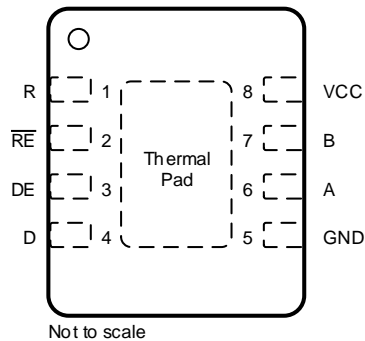

Pin Functions

NAME	PIN			I/O	DESCRIPTION
	D	DGK	DRB		
A	6	6	6	Bus input/output	Bus I/O port, A (complementary to B)
B	7	7	7	Bus input/output	Bus I/O port, B (complementary to A)
D	4	4	4	Digital input	Driver data input
DE	3	3	3	Digital input	Driver enable, active high (2-MΩ internal pull-down)
GND	5	5	5	Ground	Device ground
R	1	1	1	Digital output	Receive data output
V _{CC}	8	8	8	Power	3.3-V to 5-V supply
RE	2	2	2	Digital input	Receiver enable, active low (2-MΩ internal pull-up)
Thermal Pad	—	—		I/O	No electrical connection. Should be connected to GND for optimal thermal performance.

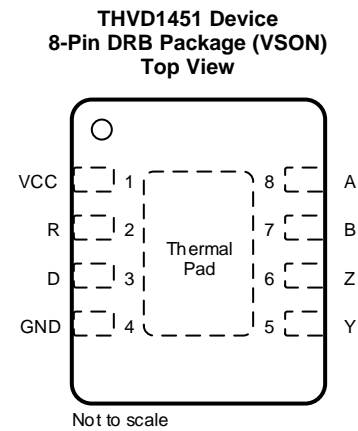
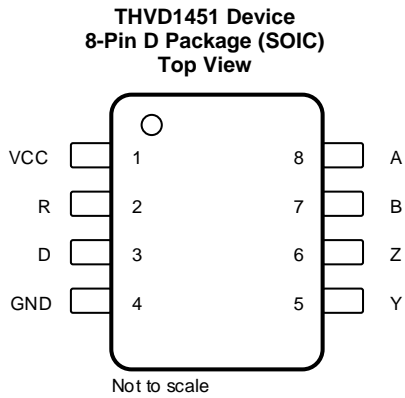

Pin Functions

NAME	PIN		I/O	Description
	D	DRB		
A	8	8	Bus input	Bus input, A (complementary to B)
B	7	7	Bus input	Bus input, B (complementary to A)
D	3	3	Digital input	Driver data input
GND	4	4	Ground	Device ground
R	2	2	Digital output	Receive data output
V _{CC}	1	1	Power	3.3-V to 5-V supply
Y	5	5	Bus output	Digital bus output, Y (Complementary to Z)
Z	6	6	Bus output	Digital bus output, Z (Complementary to Y)
Thermal Pad	—		I/O	No electrical connection. Should be connected to GND for optimal thermal performance.

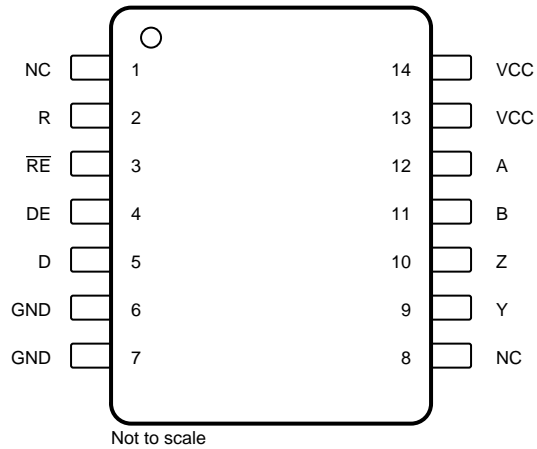
**THVD1452 Device
14-Pin D Package (SOIC)
Top View**

NC – No internal connection

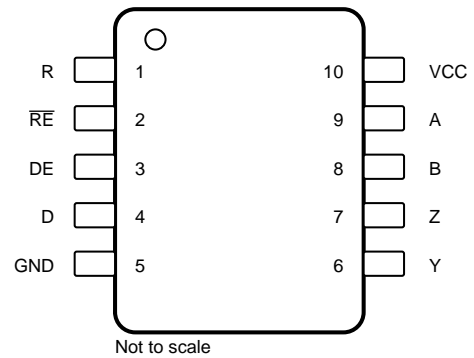
**THVD1452 Device
10-Pin DGS Package (VSSOP)
Top View**

Pin Functions

NAME	PIN		I/O	DESCRIPTION
	D	DGS		
A	12	9	Bus input	Bus input, A (complementary to B)
B	11	8	Bus input	Bus input, B (complementary to A)
D	5	4	Digital input	Driver data input
DE	4	3	Digital input	Driver enable, active high (2-MΩ internal pull-down)
GND	6, 7 ⁽¹⁾	5	Ground	Device ground
NC	1, 8	—	—	Internally not connected
R	2	1	Digital output	Receive data output
V _{CC}	13, 14 ⁽¹⁾	10	Power	3.3-V to 5-V supply
Y	9	6	Bus output	Digital bus output, Y (Complementary to Z)
Z	10	7	Bus output	Digital bus output, Z (Complementary to Y)
RE	3	2	Digital input	Receiver enable, active low (2-MΩ internal pull-up)

(1) These pins are internally connected

7 Specifications

7.1 Absolute Maximum Ratings

over operating free-air temperature range (unless otherwise noted)⁽¹⁾

		MIN	MAX	UNIT
Supply voltage	V_{CC}	-0.5	7	V
Bus voltage	Range at any bus pin (A, B, Y, or Z) as differential or common-mode with respect to GND	-18	18	V
Input voltage	Range at any logic pin (D, DE, or \overline{RE})	-0.3	5.7	V
Receiver output current	I_O	-24	24	mA
Storage temperature range		-65	150	°C

(1) Stresses beyond those listed under Absolute Maximum Ratings may cause permanent damage to the device. These are stress ratings only, which do not imply functional operation of the device at these or any other conditions beyond those indicated under Recommended Operating Conditions. Exposure to absolute-maximum-rated conditions for extended periods may affect device reliability.

7.2 ESD Ratings

			VALUE	UNIT	
$V_{(ESD)}$	Electrostatic discharge	Human body model (HBM), per ANSI/ESDA/JEDEC JS-001 ⁽¹⁾	Bus pins and GND	±30	kV
			All other pins	±8	kV
		Charged device model (CDM), per JEDEC JESD22-C101 ⁽²⁾	All pins	±1.5	kV
		Machine model (MM), per JEDEC JESD22-A115-A	All pins	±200	V

(1) JEDEC document JEP155 states that 500-V HBM allows safe manufacturing with a standard ESD control process.

(2) JEDEC document JEP157 states that 250-V CDM allows safe manufacturing with a standard ESD control process.

7.3 ESD Ratings [IEC]

			VALUE	UNIT	
$V_{(ESD)}$	Electrostatic discharge	Contact discharge, per IEC 61000-4-2	Bus pins and GND	±18	kV
		Air-gap discharge, per IEC 61000-4-2	Bus pins and GND	±25	kV
$V_{(EFT)}$	Electrical fast transient	Per IEC 61000-4-4	Bus pins and GND	±4	kV

7.4 Recommended Operating Conditions

over operating free-air temperature range (unless otherwise noted)

		MIN	NOM	MAX	UNIT
V _{CC}	Supply voltage	3		5.5	V
V _I	Input voltage at any bus terminal ⁽¹⁾	-15		15	V
V _{IH}	High-level input voltage (driver, driver enable, and receiver enable inputs)	2		V _{CC}	V
V _{IL}	Low-level input voltage (driver, driver enable, and receiver enable inputs)	0		0.8	V
V _{ID}	Differential input voltage	-15		15	V
I _O	Output current, driver	-60		60	mA
I _{OR}	Output current, receiver	-8		8	mA
R _L	Differential load resistance	54			Ω
1/t _{UI}	Signaling rate: THVD1410			500	kbps
1/t _{UI}	Signaling rate: THVD1450, THVD1451, THVD1452			50	Mbps
T _A	Operating ambient temperature	-40		125	°C
T _J	Junction temperature	-40		150	°C

(1) The algebraic convention, in which the least positive (most negative) limit is designated as minimum is used in this data sheet.

7.5 Thermal Information

THERMAL METRIC ⁽¹⁾		THVD1410 THVD1450 THVD1451	THVD1452	THVD1410 THVD1450	THVD1452	THVD1450 THVD1451	UNIT
		D (SOIC)	D (SOIC)	DGK (VSSOP)	DGS (VSSOP)	DRB (VSON)	
		8 PINS	14 PINS	8 PINS	10 PINS	8 PINS	
R _{θJA}	Junction-to-ambient thermal resistance	114.3	86.4	155.2	155.6	48.6	°C/W
R _{θJC(to p)}	Junction-to-case (top) thermal resistance	56.7	43.7	47.2	49.3	49.1	°C/W
R _{θJB}	Junction-to-board thermal resistance	57.7	42.5	76.1	77.1	21.1	°C/W
Ψ _{JT}	Junction-to-top characterization parameter	12.8	10.2	3.9	4.5	0.8	°C/W
Ψ _{JB}	Junction-to-board characterization parameter	57	42.2	74.8	75.7	21.1	°C/W
R _{θJC(bot)}	Junction-to-case (bottom) thermal resistance	N/A	N/A	N/A	N/A	2.7	°C/W

(1) For more information about traditional and new thermal metrics, see the [Semiconductor and IC Package Thermal Metrics](#) application report.

7.6 Power Dissipation

PARAMETER	Description	TEST CONDITIONS	MIN	TYP	MAX	UNIT
P _D	Driver and receiver enabled, V _{CC} = 5.5 V, T _A = 125°C, 50% duty cycle square wave at 500kbps signaling rate, THVD1410	Unterminated: R _L = 300 Ω, C _L = 50 pF		360		mW
		RS-422 load: R _L = 100 Ω, C _L = 50 pF		370		mW
		RS-485 load: R _L = 54 Ω, C _L = 50 pF		410		mW
	Driver and receiver enabled, V _{CC} = 5.5 V, T _A = 125°C, 50% duty cycle square wave at 50Mbps signaling rate, THVD145x devices	Unterminated: R _L = 300 Ω, C _L = 50 pF		360		mW
		RS-422 load: R _L = 100 Ω, C _L = 50 pF		320		mW
		RS-485 load: R _L = 54 Ω, C _L = 50 pF		330		mW

7.7 Electrical Characteristics

over operating free-air temperature range (unless otherwise noted). All typical values are at 25°C and supply voltage of $V_{CC} = 5\text{ V}$.

PARAMETER		TEST CONDITIONS		MIN	TYP	MAX	UNIT
Driver							
$ V_{OD} $	Driver differential output voltage magnitude	$R_L = 60\ \Omega$, $-15\text{ V} \leq V_{\text{test}} \leq 15\text{ V}$ (See Figure 20) ⁽¹⁾		1.5	3.5		V
		$R_L = 60\ \Omega$, $-15\text{ V} \leq V_{\text{test}} \leq 15\text{ V}$, $4.5\text{ V} \leq V_{CC} \leq 5.5\text{ V}$, (See Figure 20)		2.1			V
		$R_L = 100\ \Omega$ (See Figure 21)		2	4		V
		$R_L = 54\ \Omega$ (See Figure 21)		1.5	3.5		V
$\Delta V_{OD} $	Change in differential output voltage			-200		200	mV
V_{OC}	Common-mode output voltage	$R_L = 54\ \Omega$ (See Figure 21)		1	$V_{CC}/2$	3	V
$\Delta V_{OC(SS)}$	Change in steady-state common-mode output voltage			-200		200	mV
I_{OS}	Short-circuit output current	$DE = V_{CC}$, $-7\text{ V} \leq V_O \leq 12\text{ V}$		-250		250	mA
Receiver							
I_I	Bus input current	$DE = 0\text{ V}$, $V_{CC} = 0\text{ V}$ or 5.5 V	$V_I = 12\text{ V}$		50	125	μA
			$V_I = -7\text{ V}$	-100	-65		μA
		$DE = 0\text{ V}$, $V_{CC} = 0\text{ V}$ or 5.5 V	$V_I = 15\text{ V}$		60	125	μA
			$V_I = -15\text{ V}$	-200	-130		μA
V_{TH+}	Positive-going input threshold voltage			See ⁽²⁾	-100	-20	mV
V_{TH-}	Negative-going input threshold voltage	Over common-mode range of $\pm 15\text{ V}$		-200	-130	See ⁽²⁾	mV
V_{HYS}	Input hysteresis				30		mV
V_{OH}	Output high voltage	$I_{OH} = -8\text{ mA}$		$V_{CC} - 0.4$	$V_{CC} - 0.2$		V
V_{OL}	Output low voltage	$I_{OL} = 8\text{ mA}$			0.2	0.4	V
I_{OZR}	Output high-impedance current	$V_O = 0\text{ V}$ or V_{CC} , $\overline{RE} = V_{CC}$		-1		1	μA
Logic							
I_{IN}	Input current (D, DE, \overline{RE})	$3\text{ V} \leq V_{CC} \leq 5.5\text{ V}$, $0\text{ V} \leq V_{IN} \leq V_{CC}$		-6.2		6.2	μA
Device							
I_{CC}	Supply current (quiescent)	Driver and receiver enabled	$\overline{RE} = 0\text{ V}$, $DE = V_{CC}$, No load		2.4	3	mA
		Driver enabled, receiver disabled	$\overline{RE} = V_{CC}$, $DE = V_{CC}$, No load		2	2.5	mA
		Driver disabled, receiver enabled	$\overline{RE} = 0\text{ V}$, $DE = 0\text{ V}$, No load		700	960	μA
		Driver and receiver disabled	$\overline{RE} = V_{CC}$, $DE = 0\text{ V}$, D = open, No load		0.1	1	μA
T_{SD}	Thermal shutdown temperature				170		°C

(1) $|V_{OD}| \geq 1.4\text{ V}$ when $T_A > 85\text{ }^\circ\text{C}$, $V_{\text{test}} < -7\text{ V}$ and $V_{CC} < 3.135\text{ V}$.

(2) Under any specific conditions, V_{TH+} is assured to be at least V_{HYS} higher than V_{TH-} .

7.8 Switching Characteristics

over operating free-air temperature range (unless otherwise noted). All typical values are at 25°C and supply voltage of $V_{CC} = 5\text{ V}$.

PARAMETER		TEST CONDITIONS	MIN	TYP	MAX	UNIT	
Driver: THVD1410							
t_r, t_f	Differential output rise/fall time	$R_L = 54\ \Omega, C_L = 50\ \text{pF}$, See Figure 22	250	460	680	ns	
t_{PHL}, t_{PLH}	Propagation delay			250	500	ns	
$t_{SK(P)}$	Pulse skew, $ t_{PHL} - t_{PLH} $				10	ns	
t_{PHZ}, t_{PLZ}	Disable time			80	200	ns	
t_{PZH}, t_{PZL}	Enable time	$\overline{RE} = 0\text{ V}$, See Figure 23 and Figure 24		100	600	ns	
		$\overline{RE} = V_{CC}$, See Figure 23 and Figure 24		4	11	μs	
Receiver: THVD1410							
t_r, t_f	Output rise/fall time	$C_L = 15\ \text{pF}$, See Figure 25		10	20	ns	
t_{PHL}, t_{PLH}	Propagation delay			35	110	ns	
$t_{SK(P)}$	Pulse skew, $ t_{PHL} - t_{PLH} $				7	ns	
t_{PHZ}, t_{PLZ}	Disable time			30	60	ns	
$t_{PZH(1)}, t_{PZL(1)}, t_{PZH(2)}, t_{PZL(2)}$	Enable time	$DE = V_{CC}$, See Figure 26		60	140	ns	
		$DE = 0\text{ V}$, See Figure 27		6	14	μs	
Driver: THVD1450, THVD1451, THVD1452							
t_r, t_f	Differential output rise/fall time	$R_L = 54\ \Omega, C_L = 50\ \text{pF}$, See Figure 22	1	3	6	ns	
t_{PHL}, t_{PLH}	Propagation delay			3	10	20	ns
$t_{SK(P)}$	Pulse skew, $ t_{PHL} - t_{PLH} $					3.5	ns
t_{PHZ}, t_{PLZ}	Disable time			15	25	ns	
t_{PZH}, t_{PZL}	Enable time	$\overline{RE} = 0\text{ V}$, See Figure 23 and Figure 24		20	50	ns	
		$\overline{RE} = V_{CC}$, See Figure 23 and Figure 24		2.5	10	μs	
Receiver: THVD1450, THVD1451, THVD1452							
t_r, t_f	Output rise/fall time	$C_L = 15\ \text{pF}$, See Figure 25		2	6	ns	
t_{PHL}, t_{PLH}	Propagation delay			25	40	ns	
$t_{SK(P)}$	Pulse skew, $ t_{PHL} - t_{PLH} $				3.5	ns	
t_{PHZ}, t_{PLZ}	Disable time			14	28	ns	
$t_{PZH(1)}, t_{PZL(1)}, t_{PZH(2)}, t_{PZL(2)}$	Enable time	$DE = V_{CC}$, See Figure 26		50	110	ns	
		$DE = 0\text{ V}$, See Figure 27		4	14	μs	

7.9 Typical Characteristics: All Devices

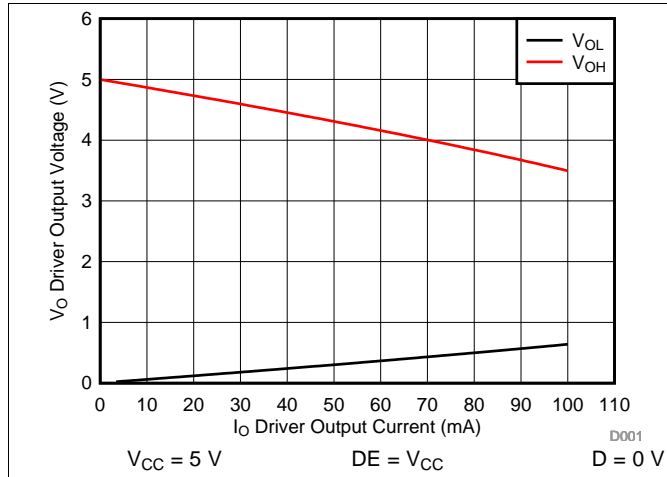

Figure 1. Driver Output Voltage vs Driver Output Current

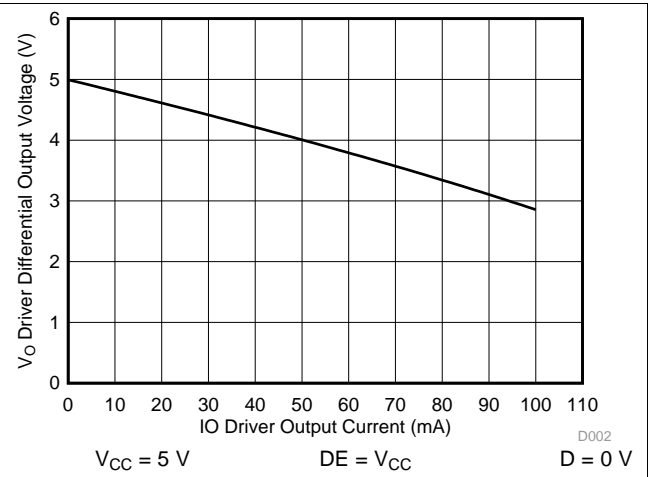

Figure 2. Driver Differential Output Voltage vs Driver Output Current

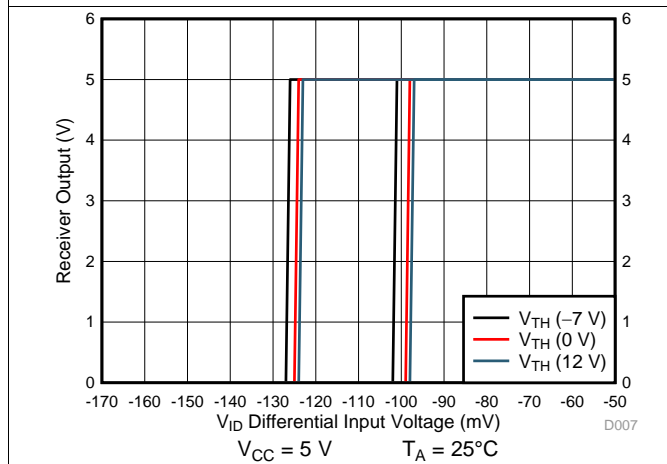

Figure 3. Receiver Output vs Input

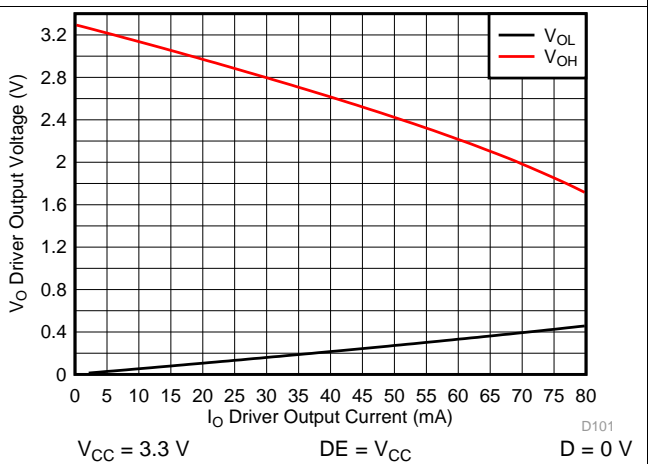

Figure 4. Driver Output Voltage vs Driver Output Current

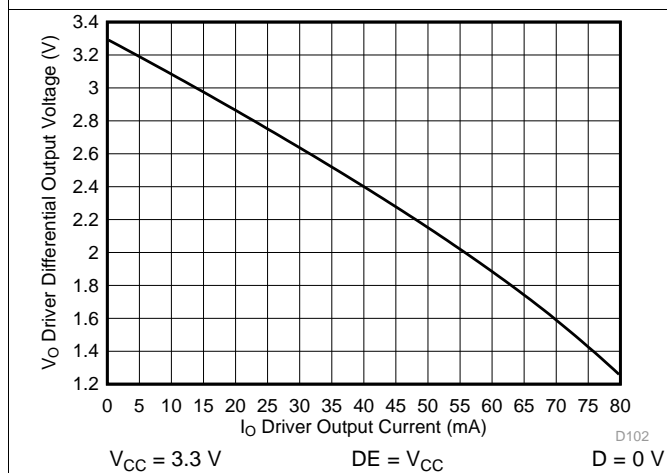

Figure 5. Driver Differential Output Voltage vs Driver Output Current

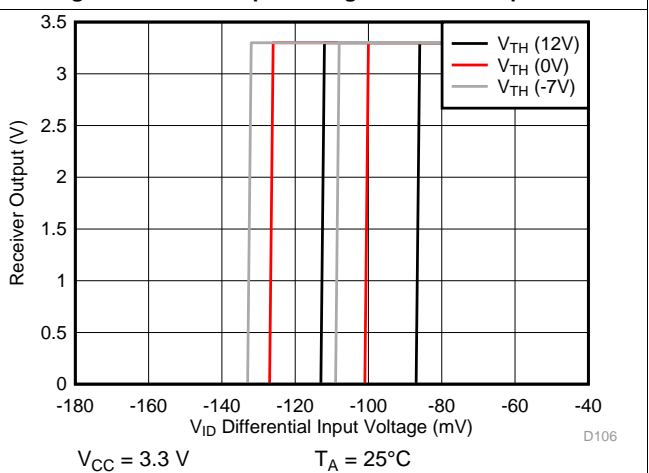
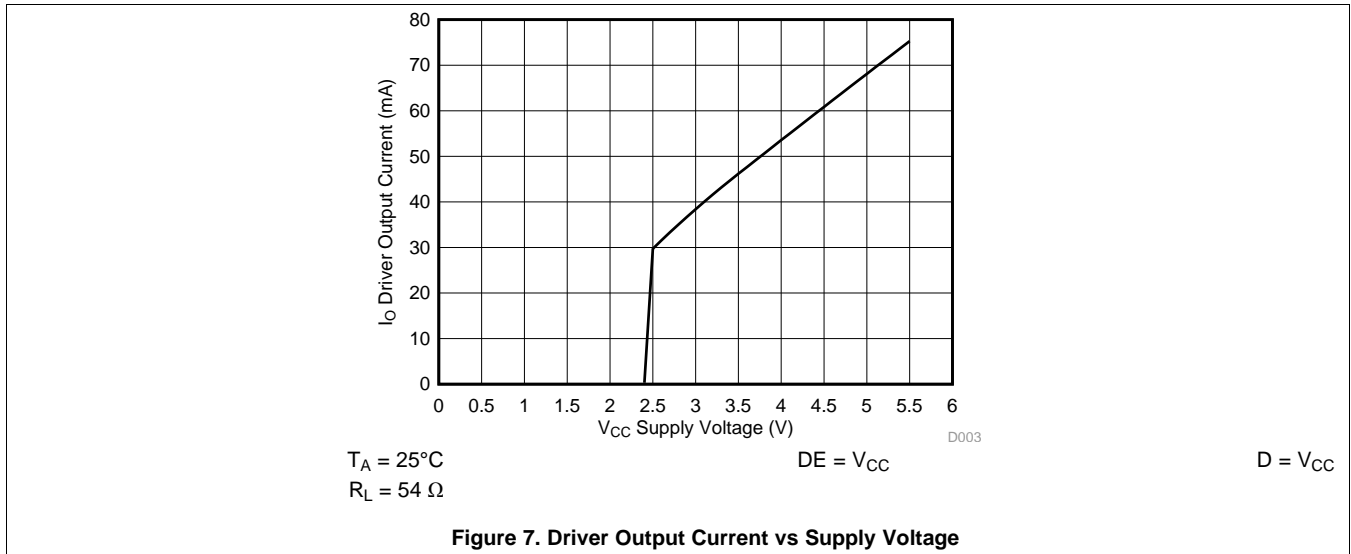
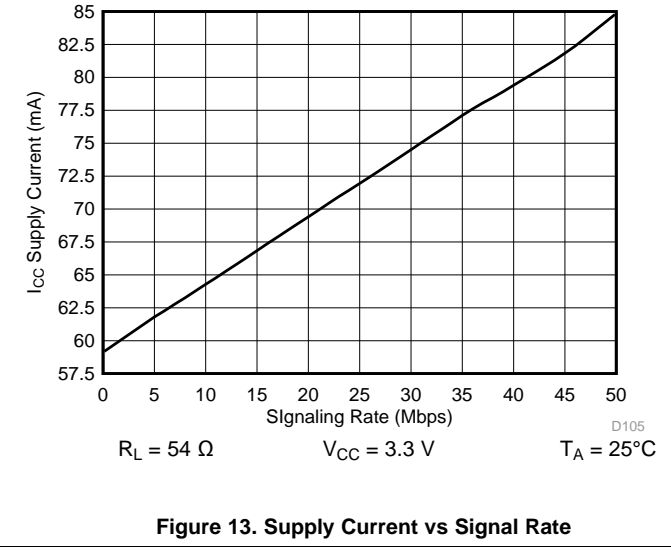
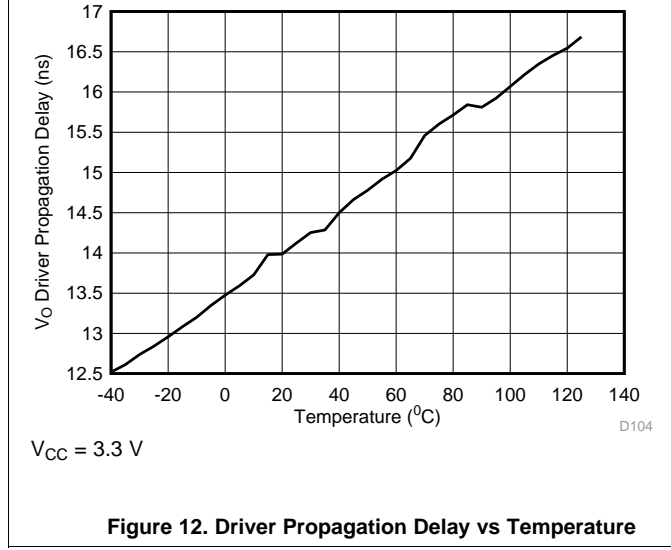
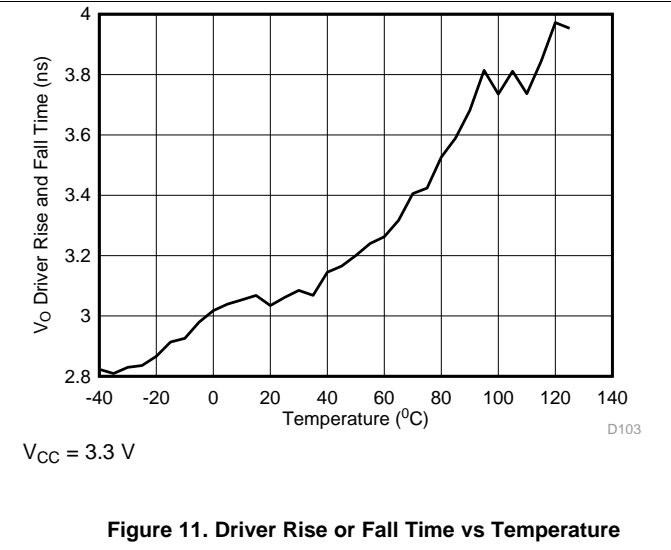
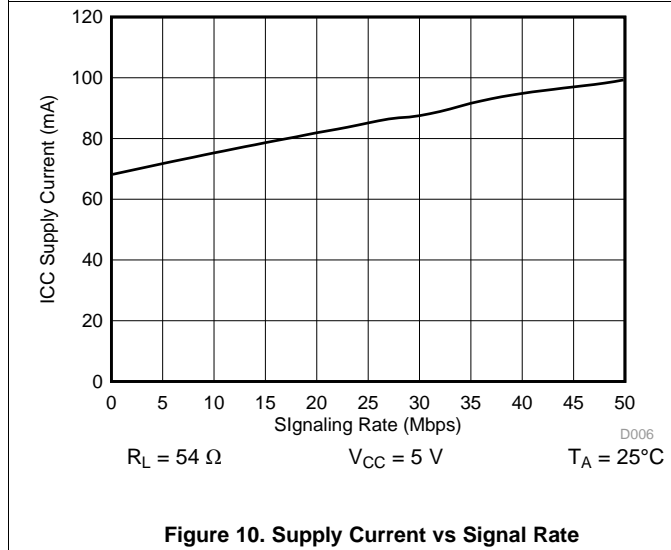
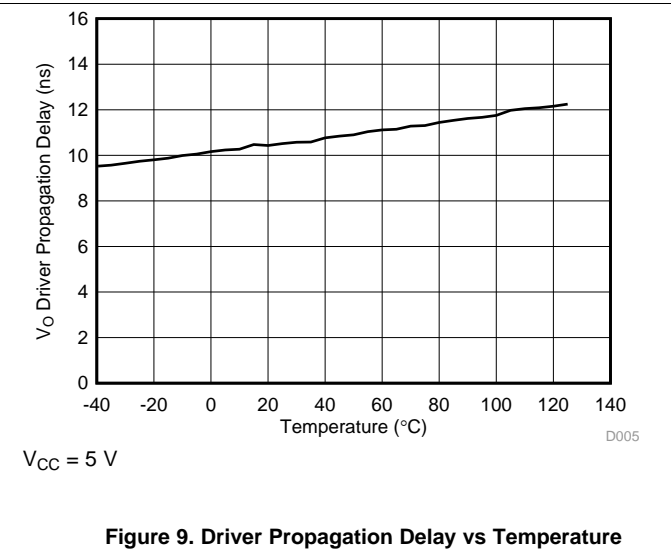
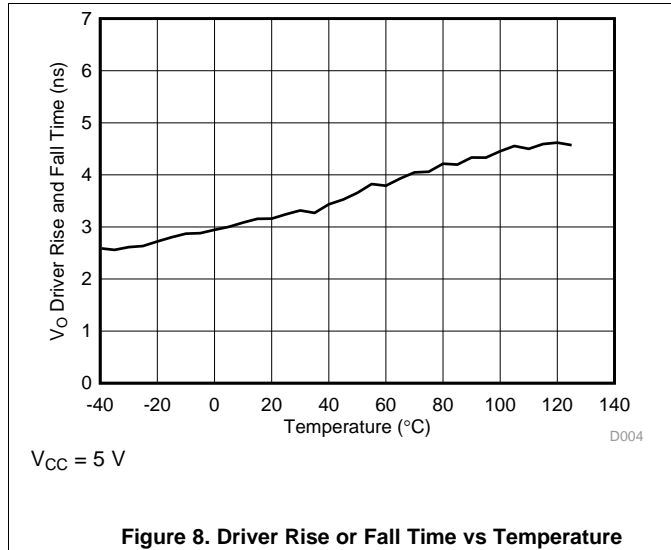

Figure 6. Receiver Output vs Input

Typical Characteristics: All Devices (continued)



7.10 Typical Characteristics: THD1450, THVD1451 and THVD1452



7.11 Typical Characteristics: THVD1410

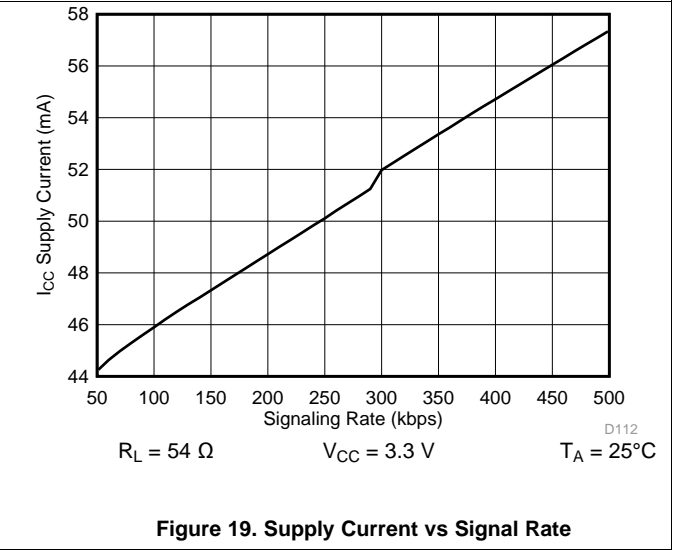
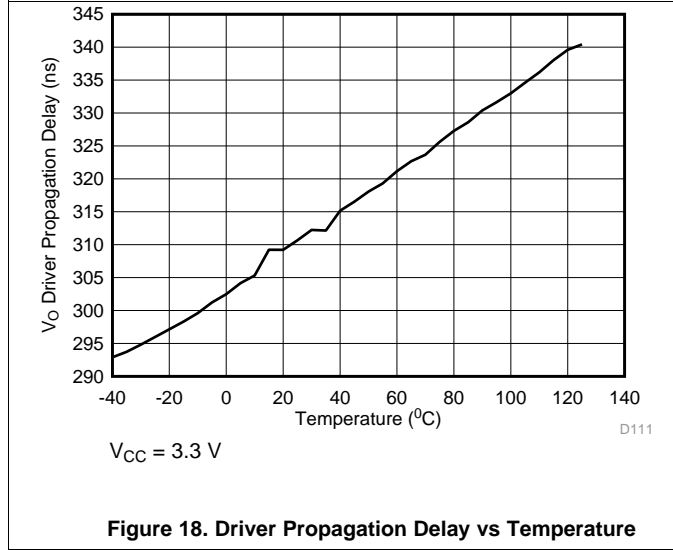
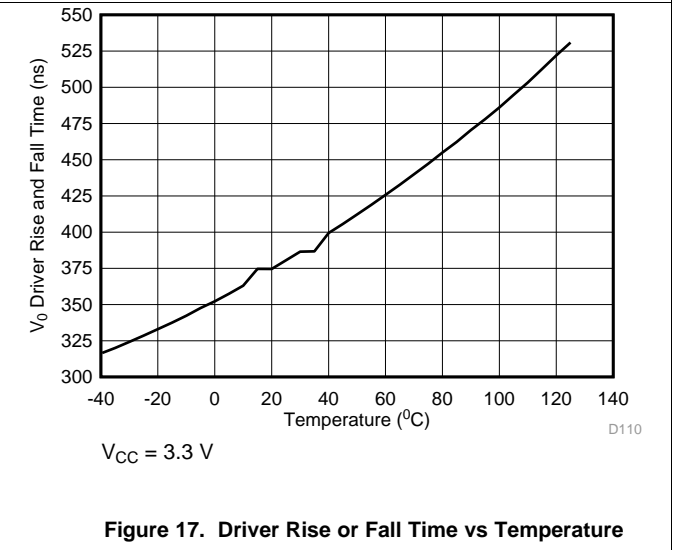
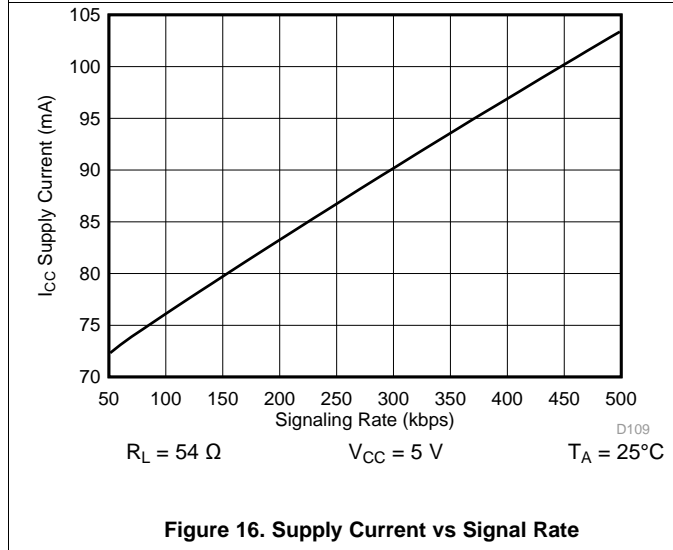
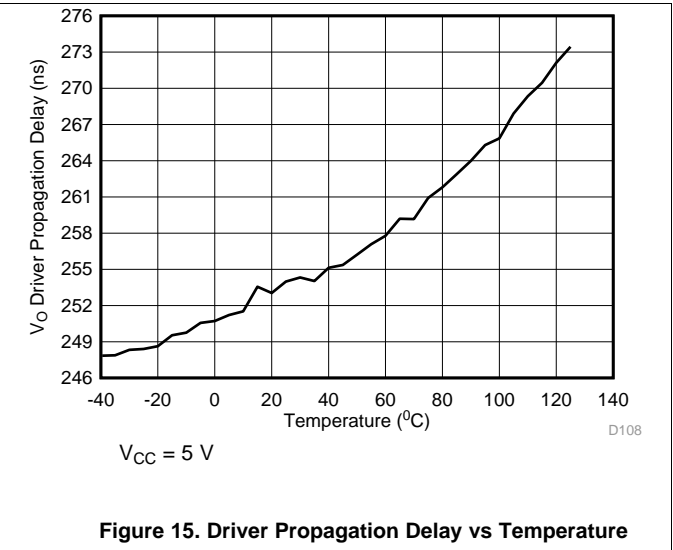
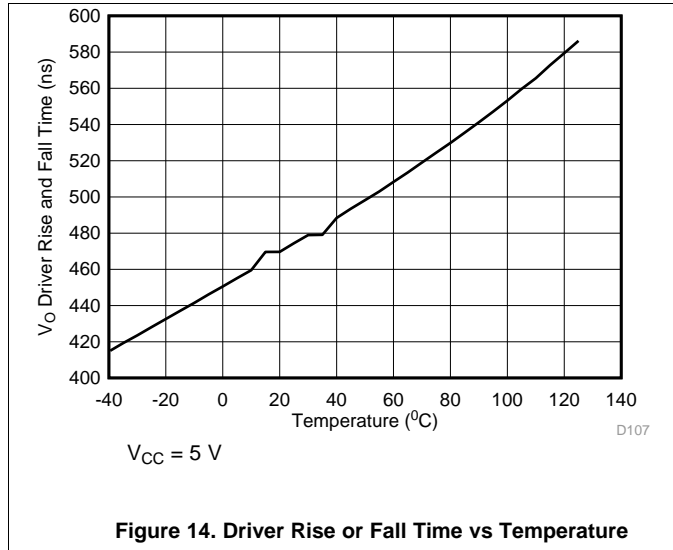

8 Parameter Measurement Information

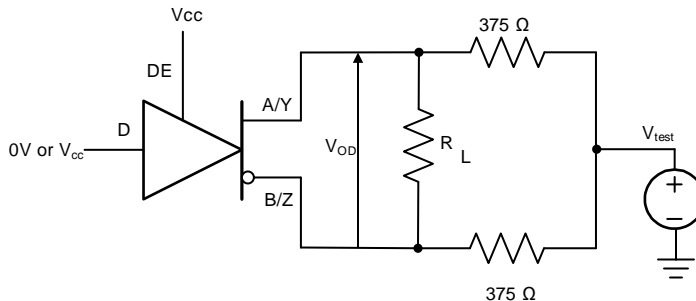

Figure 20. Measurement of Driver Differential Output Voltage With Common-Mode Load

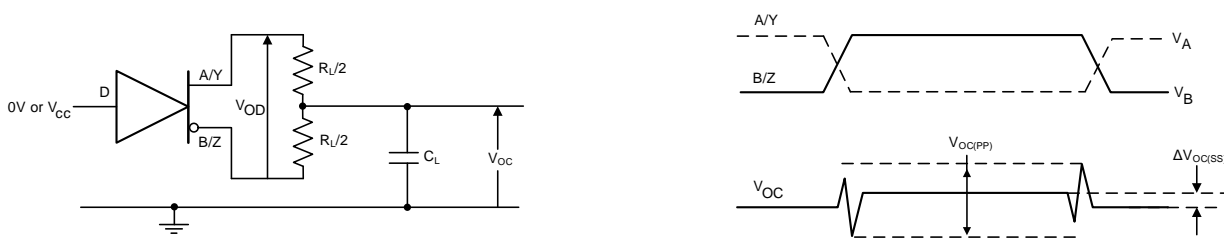

Figure 21. Measurement of Driver Differential and Common-Mode Output With RS-485 Load

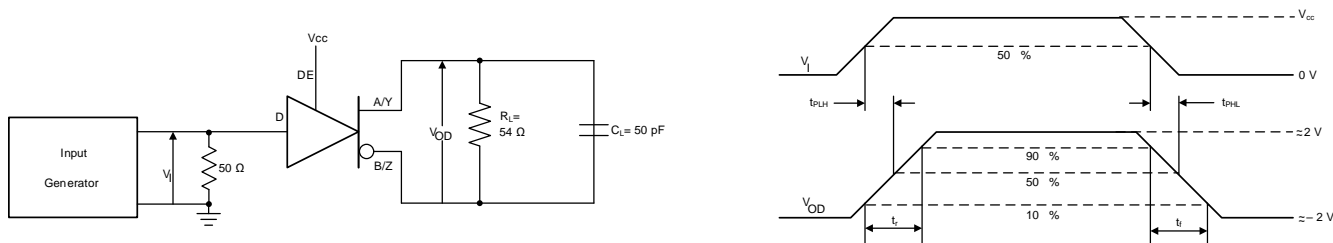

Figure 22. Measurement of Driver Differential Output Rise and Fall Times and Propagation Delays

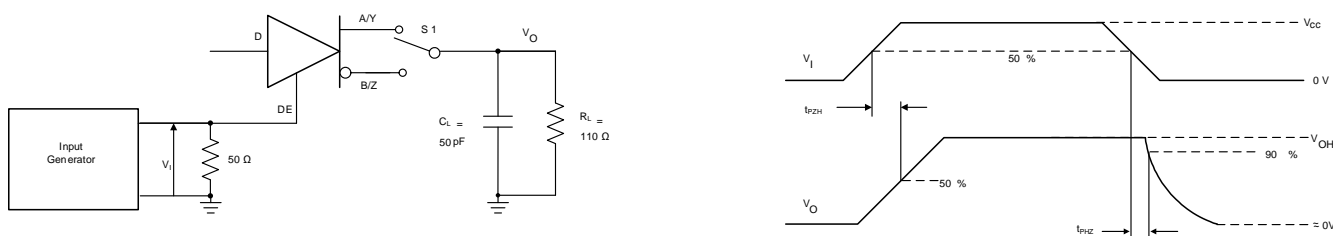

Figure 23. Measurement of Driver Enable and Disable Times With Active High Output and Pull-Down Load

Parameter Measurement Information (continued)

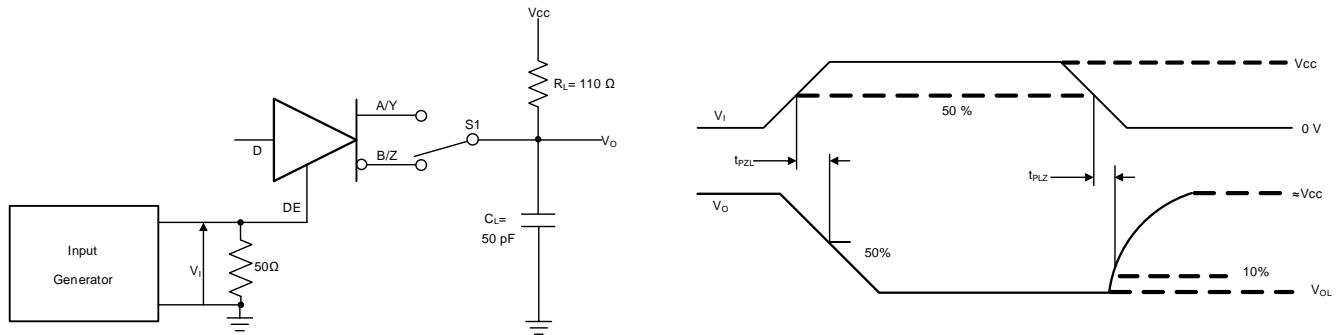

Figure 24. Measurement of Driver Enable and Disable Times With Active Low Output and Pull-up Load

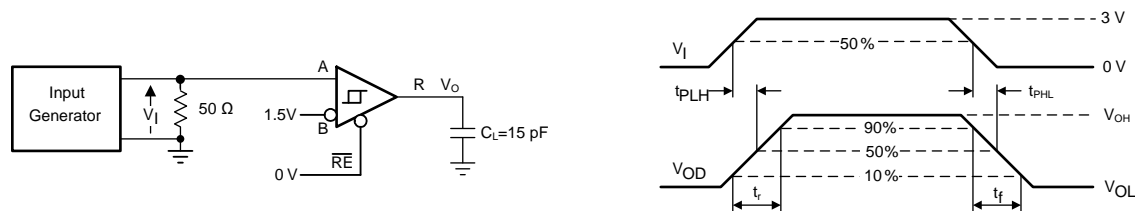

Figure 25. Measurement of Receiver Output Rise and Fall Times and Propagation Delays

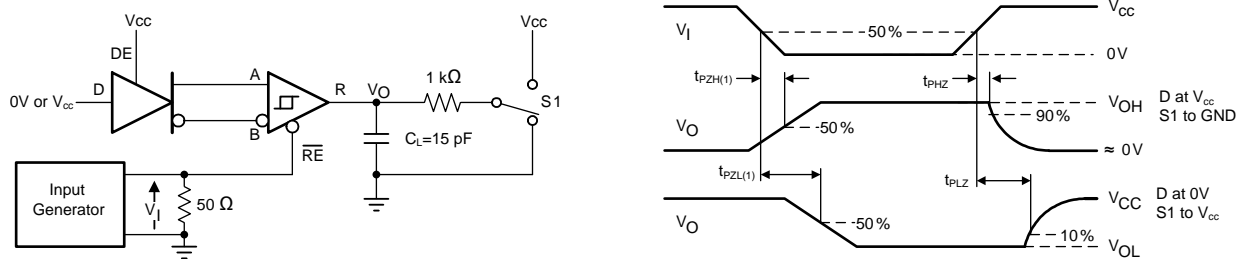

Figure 26. Measurement of Receiver Enable/Disable Times With Driver Enabled

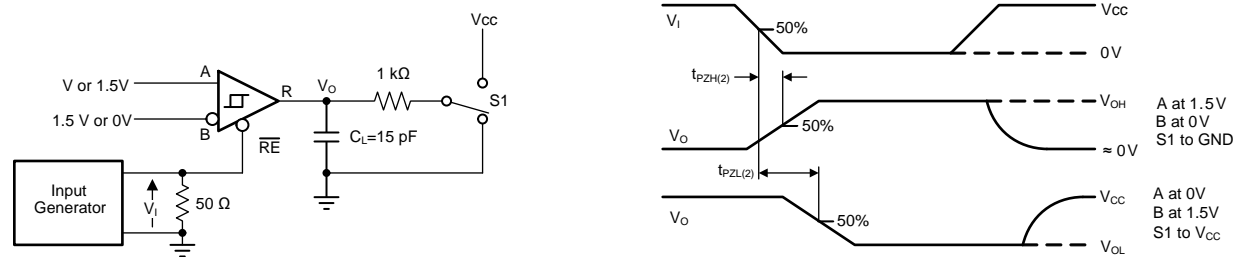

Figure 27. Measurement of Receiver Enable Times With Driver Disabled

9 Detailed Description

9.1 Overview

THVD1410 and THVD1450 are low-power, half duplex RS-485 transceivers available in two speed grades suitable for data transmission up to 500 kbps and 50 Mbps respectively.

THVD1451 is fully enabled with no external enabling pins. THVD1452 has active-high driver enable and active-low receiver enable. A standby current of less than 1 μA can be achieved by disabling both driver and receiver.

THVD14xx family of devices have a higher typical differential output voltage (V_{OD}) than traditional transceivers for better noise immunity. A minimum differential output voltage of 2.1 V is specified with V_{CC} voltage of 5 V $\pm 10\%$ to meet the requirements of PROFIBUS applications.

9.2 Functional Block Diagrams

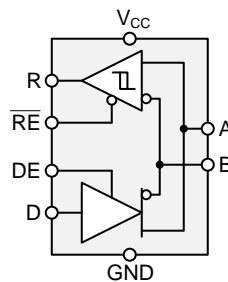

Figure 28. THVD1410 and THVD1450

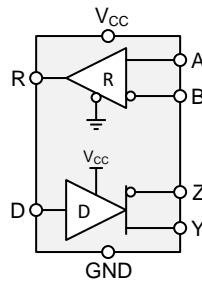

Figure 29. THVD1451

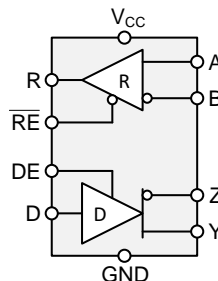

Figure 30. THVD1452

9.3 Feature Description

Internal ESD protection circuits protect the transceiver against electrostatic discharges (ESD) according to IEC 61000-4-2 of up to ± 18 kV and against electrical fast transients (EFT) according to IEC 61000-4-4 of up to ± 4 kV. With careful system design, one could achieve ± 4 kV EFT Criterion A (no data loss when transient noise is present).

The THVD14xx device family provides internal biasing of the receiver input thresholds in combination with large input-threshold hysteresis. The receiver output remains logic high under a bus-idle or bus-short conditions without the need for external failsafe biasing resistors. Device operation is specified over a wide ambient temperature range from -40°C to 125°C .

9.4 Device Functional Modes

9.4.1 Device Functional Modes for THVD1410 and THVD1450

When the driver enable pin, DE, is logic high, the differential outputs A and B follow the logic states at data input D. A logic high at D causes A to turn high and B to turn low. In this case the differential output voltage defined as $V_{OD} = V_A - V_B$ is positive. When D is low, the output states reverse: B turns high, A becomes low, and V_{OD} is negative.

When DE is low, both outputs turn high-impedance. In this condition the logic state at D is irrelevant. The DE pin has an internal pull-down resistor to ground, thus when left open the driver is disabled (high-impedance) by default. The D pin has an internal pull-up resistor to V_{CC} , thus, when left open while the driver is enabled, output A turns high and B turns low.

Table 1. Driver Function Table for THVD1410 and THVD1450

INPUT	ENABLE	OUTPUTS		FUNCTION
D	DE	A	B	
H	H	H	L	Actively drive bus high
L	H	L	H	Actively drive bus low
X	L	Z	Z	Driver disabled
X	OPEN	Z	Z	Driver disabled by default
OPEN	H	H	L	Actively drive bus high by default

When the receiver enable pin, $\overline{\text{RE}}$, is logic low, the receiver is enabled. When the differential input voltage defined as $V_{ID} = V_A - V_B$ is higher than the positive input threshold, V_{TH+} , the receiver output, R, turns high. When V_{ID} is lower than the negative input threshold, V_{TH-} , the receiver output, R, turns low. If V_{ID} is between V_{TH+} and V_{TH-} , the output is indeterminate.

When $\overline{\text{RE}}$ is logic high or left open, the receiver output is high-impedance and the magnitude and polarity of V_{ID} are irrelevant. Internal biasing of the receiver inputs causes the output to go failsafe-high when the transceiver is disconnected from the bus (open-circuit), the bus lines are shorted to one another (short-circuit), or the bus is not actively driven (idle bus).

Table 2. Receiver Function Table for THVD1410 and THVD1450

DIFFERENTIAL INPUT	ENABLE	OUTPUT	FUNCTION
$V_{ID} = V_A - V_B$	$\overline{\text{RE}}$	R	
$V_{TH+} < V_{ID}$	L	H	Receive valid bus high
$V_{TH-} < V_{ID} < V_{TH+}$	L	?	Indeterminate bus state
$V_{ID} < V_{TH-}$	L	L	Receive valid bus low
X	H	Z	Receiver disabled
X	OPEN	Z	Receiver disabled by default
Open-circuit bus	L	H	Fail-safe high output
Short-circuit bus	L	H	Fail-safe high output
Idle (terminated) bus	L	H	Fail-safe high output

9.4.2 Device Functional Modes for THVD1451

For this device, the driver and receiver are fully enabled, thus the differential outputs Y and Z follow the logic states at data input D at all times. A logic high at D causes Y to turn high and Z to turn low. In this case, the differential output voltage defined as $V_{OD} = V_Y - V_Z$ is positive. When D is low, the output states reverse: Z turns high, Y becomes low, and VOD is negative. The D pin has an internal pull-up resistor to V_{CC} , thus, when left open while the driver is enabled, output Y turns high and Z turns low.

Table 3. Driver Function Table for THVD1451

INPUT	OUTPUTS		FUNCTIONS
	Y	Z	
H	H	L	Actively drive bus high
L	L	H	Actively drive bus low
OPEN	H	L	Actively drive bus High by default

When the differential input voltage defined as $V_{ID} = V_A - V_B$ is higher than the positive input threshold, V_{TH+} , the receiver output, R, turns high. When V_{ID} is less than the negative input threshold, V_{TH-} , the receiver output, R, turns low. If V_{ID} is between V_{TH+} and V_{TH-} the output is indeterminate. Internal biasing of the receiver inputs causes the output to go failsafe-high when the transceiver is disconnected from the bus (open-circuit), the bus lines are shorted to one another (short-circuit), or the bus is not actively driven (idle bus).

Table 4. Receiver Function Table for THVD1451

DIFFERENTIAL INPUT	OUTPUT	FUNCTION
$V_{ID} = V_A - V_B$	R	
$V_{TH+} < V_{ID}$	H	Receive valid bus high
$V_{TH-} < V_{ID} < V_{TH+}$?	Indeterminate bus state
$V_{ID} < V_{TH-}$	L	Receive valid bus low
Open-circuit bus	H	Fail-safe high output
Short-circuit bus	H	Fail-safe high output
Idle (terminated) bus	H	Fail-safe high output

9.4.3 Device Functional Modes for THVD1452

When the driver enable pin, DE, is logic high, the differential outputs Y and Z follow the logic states at data input D. A logic high at D causes Y to turn high and Z to turn low. In this case the differential output voltage defined as $V_{OD} = V_Y - V_Z$ is positive. When D is low, the output states reverse: Z turns high, Y becomes low, and V_{OD} is negative.

When DE is low, both outputs turn high-impedance. In this condition the logic state at D is irrelevant. The DE pin has an internal pull-down resistor to ground, thus when left open the driver is disabled (high-impedance) by default. The D pin has an internal pull-up resistor to V_{CC} , thus, when left open while the driver is enabled, output Y turns high and Z turns low.

Table 5. Driver Function Table for THVD1452

INPUT	ENABLE	OUTPUTS		FUNCTION
D	DE	Y	Z	
H	H	H	L	Actively drive bus high
L	H	L	H	Actively drive bus low
X	L	Z	Z	Driver disabled
X	OPEN	Z	Z	Driver disabled by default
OPEN	H	H	L	Actively drive bus high by default

When the receiver enable pin, \overline{RE} , is logic low, the receiver is enabled. When the differential input voltage defined as $V_{ID} = V_A - V_B$ is higher than the positive input threshold, V_{TH+} , the receiver output, R, turns high. When V_{ID} is lower than the negative input threshold, V_{TH-} , the receiver output, R, turns low. If V_{ID} is between V_{TH+} and V_{TH-} , the output is indeterminate.

When \overline{RE} is logic high or left open, the receiver output is high-impedance and the magnitude and polarity of V_{ID} are irrelevant. Internal biasing of the receiver inputs causes the output to go failsafe-high when the transceiver is disconnected from the bus (open-circuit), the bus lines are shorted to one another (short-circuit), or the bus is not actively driven (idle bus).

Table 6. Receiver Function Table for THVD1452

DIFFERENTIAL INPUT	ENABLE	OUTPUT	FUNCTION
$V_{ID} = V_A - V_B$	\overline{RE}	R	
$V_{TH+} < V_{ID}$	L	H	Receive valid bus high
$V_{TH-} < V_{ID} < V_{TH+}$	L	?	Indeterminate bus state
$V_{ID} < V_{TH-}$	L	L	Receive valid bus low
X	H	Z	Receiver disabled
X	OPEN	Z	Receiver disabled by default
Open-circuit bus	L	H	Fail-safe high output
Short-circuit bus	L	H	Fail-safe high output
Idle (terminated) bus	L	H	Fail-safe high output

10 Application and Implementation

NOTE

Information in the following applications sections is not part of the TI component specification, and TI does not warrant its accuracy or completeness. TI's customers are responsible for determining suitability of components for their purposes. Customers should validate and test their design implementation to confirm system functionality.

10.1 Application Information

The THVD14xx family consists of half-duplex and full-duplex RS-485 transceivers commonly used for asynchronous data transmissions. For half-duplex devices, the driver and receiver enable pins allow for the configuration of different operating modes. Full-duplex implementation requires two signal pairs (four wires), and allows each node to transmit data on one pair while simultaneously receiving data on the other pair.

10.2 Typical Application

An RS-485 bus consists of multiple transceivers connecting in parallel to a bus cable. To eliminate line reflections, each cable end is terminated with a termination resistor, R_T , whose value matches the characteristic impedance, Z_0 , of the cable. This method, known as parallel termination, generally allows for higher data rates over longer cable length.

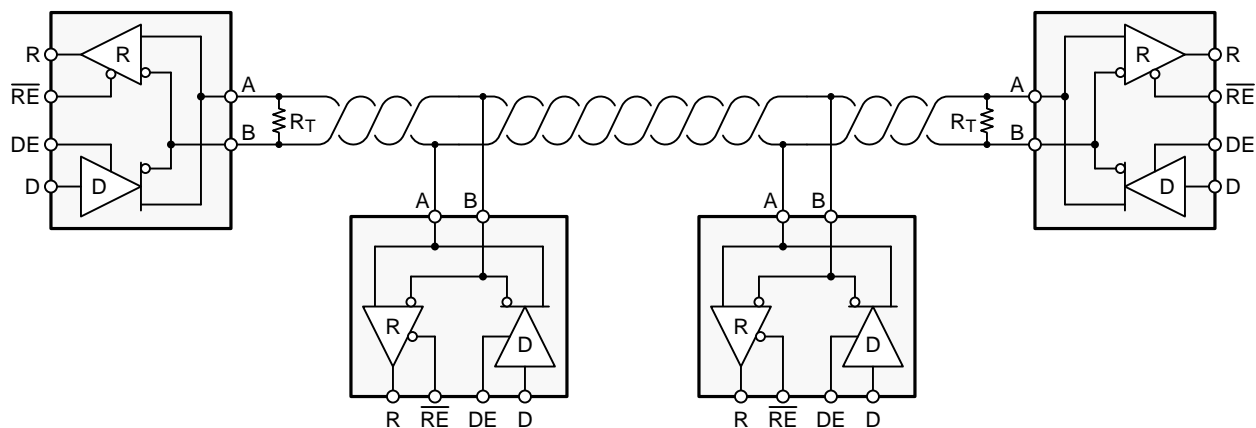

Figure 31. Typical RS-485 Network With Half-Duplex Transceivers

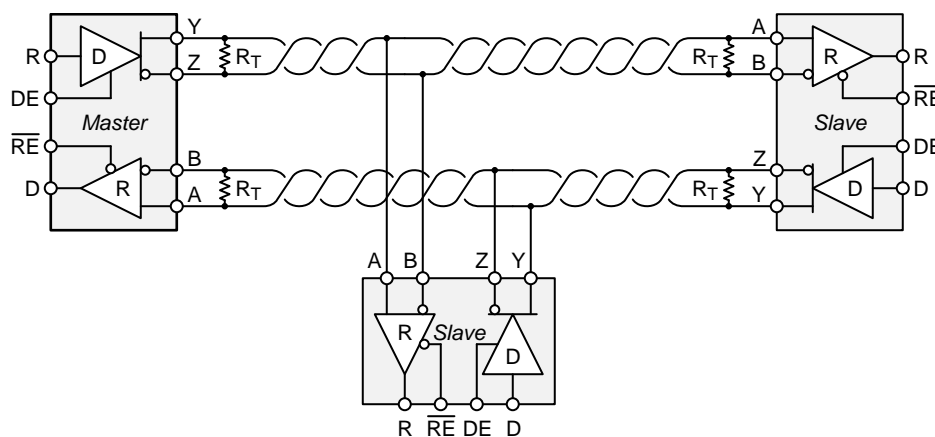

Figure 32. Typical RS-485 Network With Full-Duplex Transceivers

Typical Application (continued)

10.2.1 Design Requirements

RS-485 is a robust electrical standard suitable for long-distance networking that may be used in a wide range of applications with varying requirements, such as distance, data rate, and number of nodes.

10.2.1.1 Data Rate and Bus Length

There is an inverse relationship between data rate and cable length, which means the higher the data rate, the shorter the cable length; and conversely, the lower the data rate, the longer the cable length. While most RS-485 systems use data rates between 10 kbps and 100 kbps, some applications require data rates up to 250 kbps at distances of 4000 feet and longer. Longer distances are possible by allowing for small signal jitter of up to 5 or 10%.

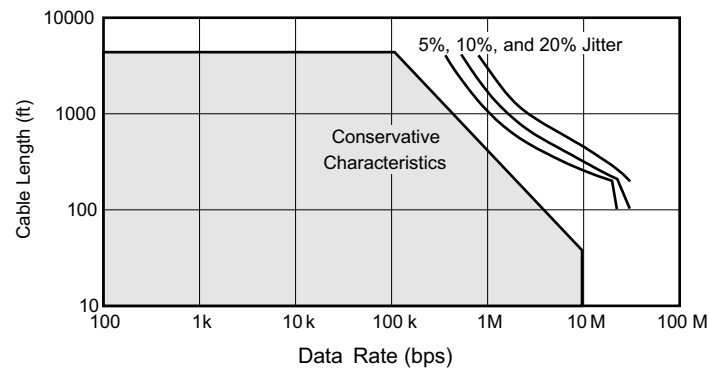

Figure 33. Cable Length vs Data Rate Characteristic

Even higher data rates are achievable (that is, 50 Mbps for the THVD1450, THVD1451 and THVD1452) in cases where the interconnect is short enough (or has suitably low attenuation at signal frequencies) to not degrade the data.

10.2.1.2 Stub Length

When connecting a node to the bus, the distance between the transceiver inputs and the cable trunk, known as the stub, should be as short as possible. Stubs present a non-terminated piece of bus line which can introduce reflections of varying phase as the length of the stub increases. As a general guideline, the electrical length, or round-trip delay, of a stub should be less than one-tenth of the rise time of the driver, thus giving a maximum physical stub length as shown in Equation 1.

$$L_{(STUB)} \leq 0.1 \times t_r \times v \times c$$

where

- t_r is the 10/90 rise time of the driver
- c is the speed of light (3×10^8 m/s)
- v is the signal velocity of the cable or trace as a factor of c

(1)

10.2.1.3 Bus Loading

The RS-485 standard specifies that a compliant driver must be able to drive 32 unit loads (UL), where 1 unit load represents a load impedance of approximately 12 k Ω . Because the THVD14xx family consists of 1/8 UL transceivers, connecting up to 256 receivers to the bus is possible.

Typical Application (continued)

10.2.1.4 Receiver Failsafe

The differential receivers of the THVD14xx family are *failsafe* to invalid bus states caused by the following:

- Open bus conditions, such as a disconnected connector
- Shorted bus conditions, such as cable damage shorting the twisted-pair together
- Idle bus conditions that occur when no driver on the bus is actively driving

In any of these cases, the differential receiver will output a failsafe logic high state so that the output of the receiver is not indeterminate.

Receiver failsafe is accomplished by offsetting the receiver thresholds such that the *input indeterminate* range does not include zero volts differential. In order to comply with the RS-422 and RS-485 standards, the receiver output must output a high when the differential input V_{ID} is more positive than 200 mV, and must output a Low when V_{ID} is more negative than -200 mV. The receiver parameters which determine the failsafe performance are V_{TH+} , V_{TH-} , and V_{HYS} (the separation between V_{TH+} and V_{TH-}). As shown in the table, differential signals more negative than -200 mV will always cause a low receiver output, and differential signals more positive than 200 mV will always cause a high receiver output.

When the differential input signal is close to zero, it is still above the V_{TH+} threshold, and the receiver output will be High. Only when the differential input is more than V_{HYS} below V_{TH+} will the receiver output transition to a Low state. Therefore, the noise immunity of the receiver inputs during a bus fault conditions includes the receiver hysteresis value, V_{HYS} , as well as the value of V_{TH+} .

Typical Application (continued)

10.2.1.5 Transient Protection

The bus pins of the THVD14xx transceiver family include on-chip ESD protection against ± 30 -kV HBM and ± 18 -kV IEC 61000-4-2 contact discharge. The International Electrotechnical Commission (IEC) ESD test is far more severe than the HBM ESD test. The 50% higher charge capacitance, $C_{(S)}$, and 78% lower discharge resistance, $R_{(D)}$, of the IEC model produce significantly higher discharge currents than the HBM model. As stated in the IEC 61000-4-2 standard, contact discharge is the preferred transient protection test method.

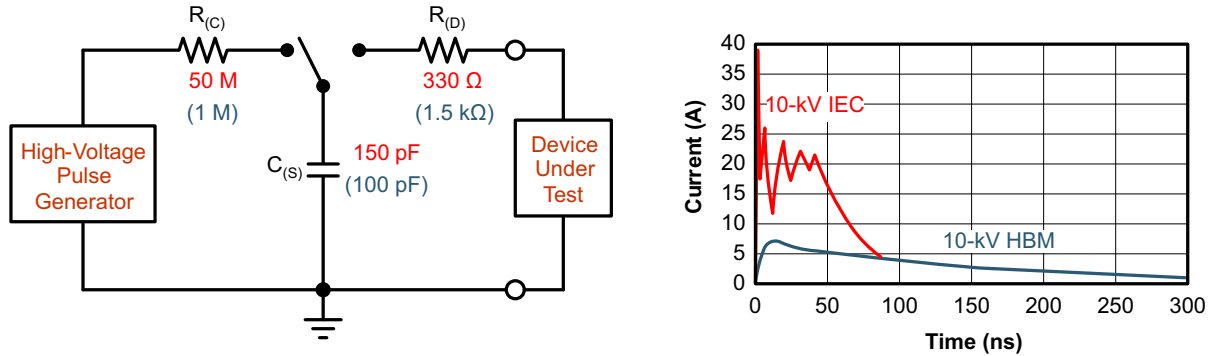

Figure 34. HBM and IEC ESD Models and Currents in Comparison (HBM Values in Parenthesis)

The on-chip implementation of IEC ESD protection significantly increases the robustness of equipment. Common discharge events occur because of human contact with connectors and cables. Designers may choose to implement protection against longer duration transients, typically referred to as surge transients.

EFTs are generally caused by relay-contact bounce or the interruption of inductive loads. Surge transients often result from lightning strikes (direct strike or an indirect strike which induce voltages and currents), or the switching of power systems, including load changes and short circuit switching. These transients are often encountered in industrial environments, such as factory automation and power-grid systems.

Figure 35 compares the pulse-power of the EFT and surge transients with the power caused by an IEC ESD transient. The left hand diagram shows the relative pulse-power for a 0.5-kV surge transient and 4-kV EFT transient, both of which dwarf the 10-kV ESD transient visible in the lower-left corner. 500-V surge transients are representative of events that may occur in factory environments in industrial and process automation.

The right hand diagram shows the pulse power of a 6-kV surge transient, relative to the same 0.5-kV surge transient. 6-kV surge transients are most likely to occur in power generation and power-grid systems.

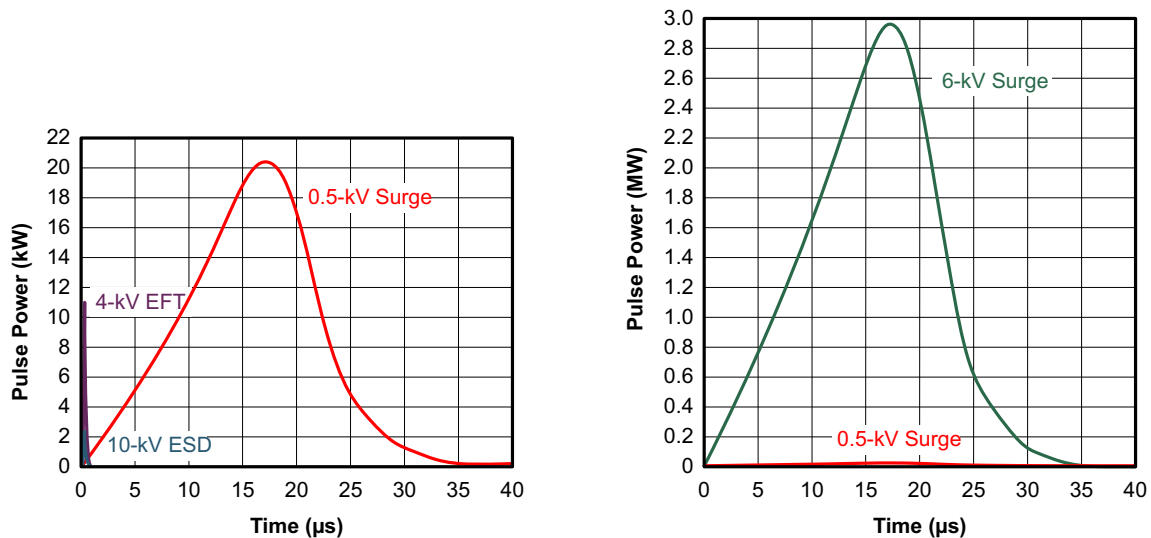

Figure 35. Power Comparison of ESD, EFT, and Surge Transients

Typical Application (continued)

If the surge transients, high-energy content is characterized by long pulse duration and slow decaying pulse power. The electrical energy of a transient that is dumped into the internal protection cells of a transceiver is converted into thermal energy, which heats and destroys the protection cells, thus destroying the transceiver. Figure 36 shows the large differences in transient energies for single ESD, EFT, surge transients, and an EFT pulse train that is commonly applied during compliance testing.

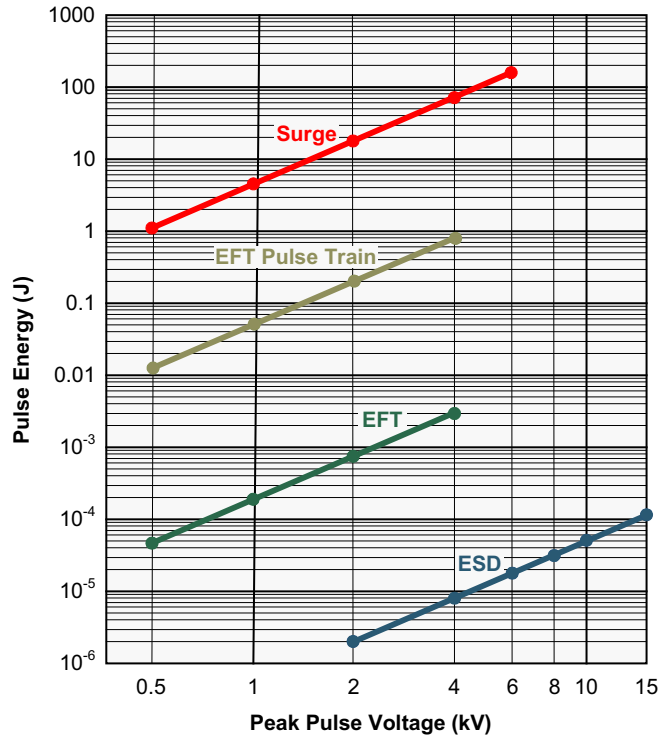

Figure 36. Comparison of Transient Energies

Typical Application (continued)

10.2.2 Detailed Design Procedure

Figure 37 and Figure 38 suggest a protection circuit against 1 kV surge (IEC 61000-4-5) transients. Table 7 shows the associated bill of materials.



Figure 37. Transient Protection Against Surge Transients for Half-Duplex Devices

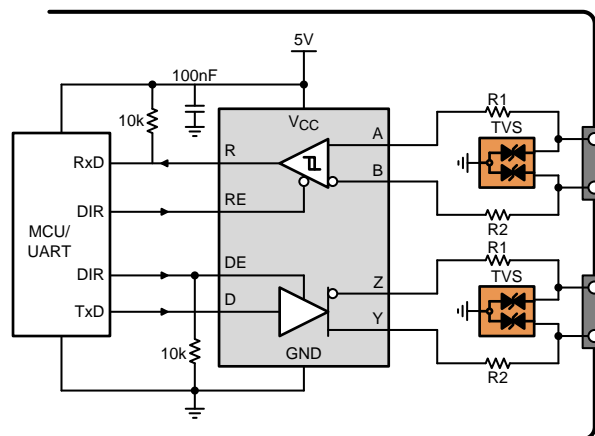
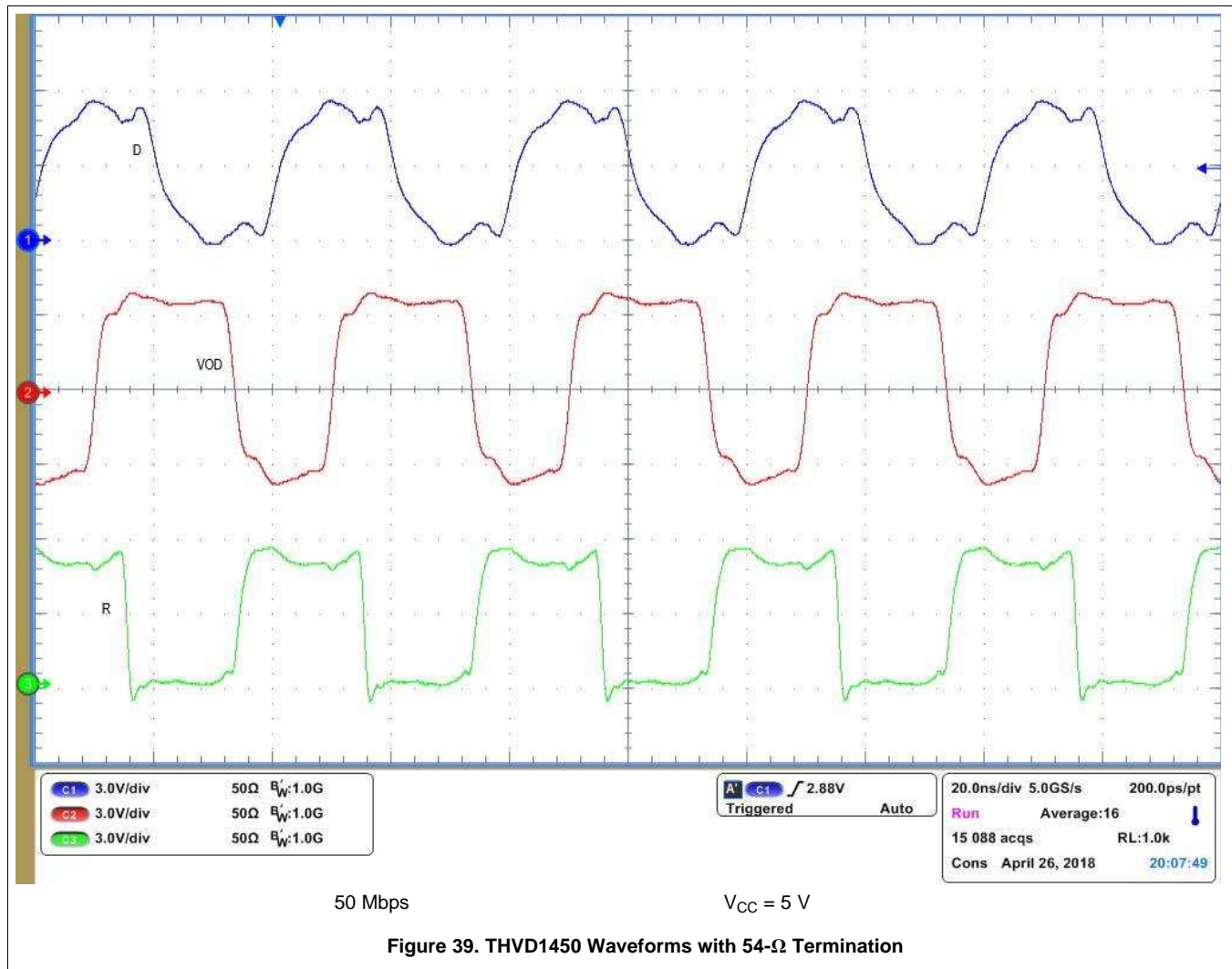

Figure 38. Transient Protection Against Surge Transients for Full-Duplex Devices

Table 7. Bill of Materials

DEVICE	FUNCTION	ORDER NUMBER	MANUFACTURER
XCVR	RS-485 transceiver	THVD14xx	TI
R1	10-Ω, pulse-proof thick-film resistor	CRCW0603010RJNEAHP	Vishay
R2			
TVS	Bidirectional 400-W transient suppressor	CDSOT23-SM712	Bourns

10.2.3 Application Curves



11 Power Supply Recommendations

To ensure reliable operation at all data rates and supply voltages, each supply should be decoupled with a 100 nF ceramic capacitor located as close to the supply pins as possible. This helps to reduce supply voltage ripple present on the outputs of switched-mode power supplies and also helps to compensate for the resistance and inductance of the PCB power planes.

12 Layout

12.1 Layout Guidelines

Robust and reliable bus node design often requires the use of external transient protection devices in order to protect against surge transients that may occur in industrial environments. Since these transients have a wide frequency bandwidth (from approximately 3 MHz to 300 MHz), high-frequency layout techniques should be applied during PCB design.

1. Place the protection circuitry close to the bus connector to prevent noise transients from penetrating your board.
2. Use V_{CC} and ground planes to provide low-inductance. Note that high-frequency currents tend to follow the path of least impedance and not the path of least resistance.
3. Design the protection components into the direction of the signal path. Do not force the transient currents to divert from the signal path to reach the protection device.
4. Apply 100-nF to 220-nF decoupling capacitors as close as possible to the V_{CC} pins of transceiver, UART and/or controller ICs on the board.
5. Use at least two vias for V_{CC} and ground connections of decoupling capacitors and protection devices to minimize effective via inductance.
6. Use 1-k Ω to 10-k Ω pull-up and pull-down resistors for enable lines to limit noise currents in these lines during transient events.
7. Insert pulse-proof resistors into the A and B bus lines if the TVS clamping voltage is higher than the specified maximum voltage of the transceiver bus pins. These resistors limit the residual clamping current into the transceiver and prevent it from latching up.
8. While pure TVS protection is sufficient for surge transients up to 1 kV, higher transients require metal-oxide varistors (MOVs) which reduce the transients to a few hundred volts of clamping voltage, and transient blocking units (TBUs) that limit transient current to less than 1 mA.

12.2 Layout Example

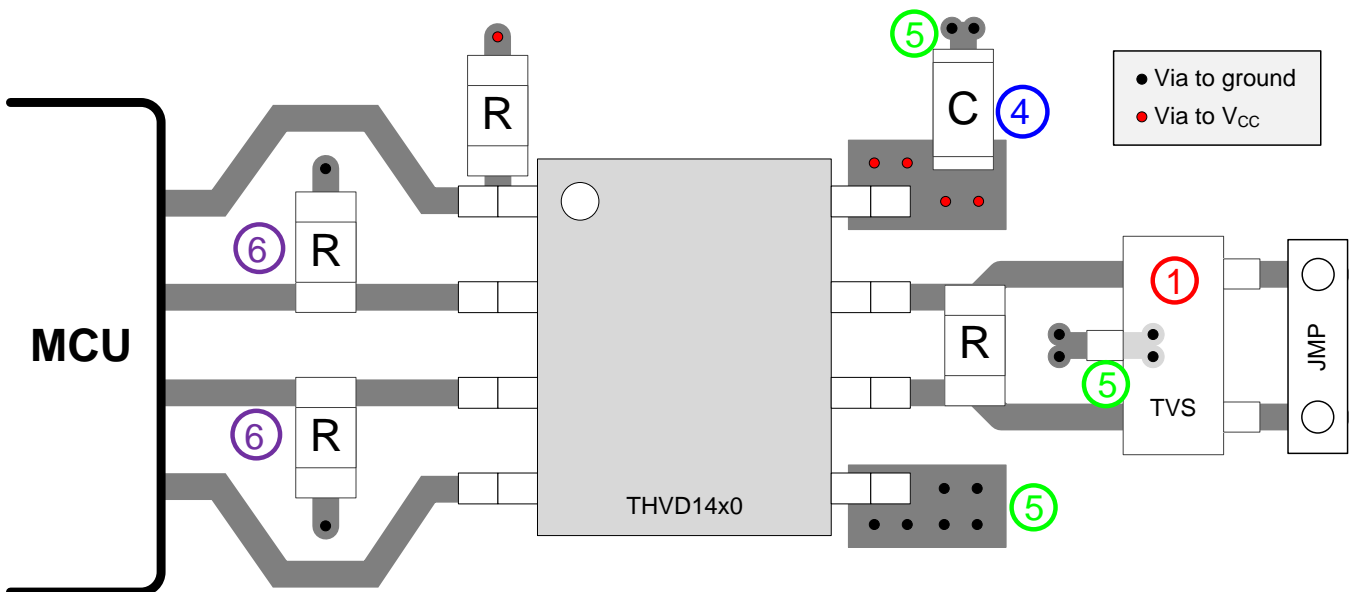

Figure 40. Half-Duplex Layout Example

13 Device and Documentation Support

13.1 Device Support

13.2 Third-Party Products Disclaimer

TI'S PUBLICATION OF INFORMATION REGARDING THIRD-PARTY PRODUCTS OR SERVICES DOES NOT CONSTITUTE AN ENDORSEMENT REGARDING THE SUITABILITY OF SUCH PRODUCTS OR SERVICES OR A WARRANTY, REPRESENTATION OR ENDORSEMENT OF SUCH PRODUCTS OR SERVICES, EITHER ALONE OR IN COMBINATION WITH ANY TI PRODUCT OR SERVICE.

13.3 Related Links

The table below lists quick access links. Categories include technical documents, support and community resources, tools and software, and quick access to order now.

Table 8. Related Links

PARTS	PRODUCT FOLDER	ORDER NOW	TECHNICAL DOCUMENTS	TOOLS & SOFTWARE	SUPPORT & COMMUNITY
THVD1410	Click here	Click here	Click here	Click here	Click here
THVD1450	Click here	Click here	Click here	Click here	Click here
THVD1451	Click here	Click here	Click here	Click here	Click here
THVD1452	Click here	Click here	Click here	Click here	Click here

13.4 Receiving Notification of Documentation Updates

To receive notification of documentation updates, navigate to the device product folder on ti.com. In the upper right corner, click on *Alert me* to register and receive a weekly digest of any product information that has changed. For change details, review the revision history included in any revised document.

13.5 Community Resources

The following links connect to TI community resources. Linked contents are provided "AS IS" by the respective contributors. They do not constitute TI specifications and do not necessarily reflect TI's views; see TI's [Terms of Use](#).

TI E2E™ Online Community *TI's Engineer-to-Engineer (E2E) Community*. Created to foster collaboration among engineers. At e2e.ti.com, you can ask questions, share knowledge, explore ideas and help solve problems with fellow engineers.

Design Support *TI's Design Support* Quickly find helpful E2E forums along with design support tools and contact information for technical support.

13.6 Trademarks

E2E is a trademark of Texas Instruments.
 All other trademarks are the property of their respective owners.

13.7 Electrostatic Discharge Caution



These devices have limited built-in ESD protection. The leads should be shorted together or the device placed in conductive foam during storage or handling to prevent electrostatic damage to the MOS gates.

13.8 Glossary

SLYZ022 — *TI Glossary*.

This glossary lists and explains terms, acronyms, and definitions.

14 Mechanical, Packaging, and Orderable Information

The following pages include mechanical, packaging, and orderable information. This information is the most current data available for the designated devices. This data is subject to change without notice and revision of this document. For browser-based versions of this data sheet, refer to the left-hand navigation.

PACKAGING INFORMATION

Orderable Device	Status (1)	Package Type	Package Drawing	Pins	Package Qty	Eco Plan (2)	Lead finish/ Ball material (6)	MSL Peak Temp (3)	Op Temp (°C)	Device Marking (4/5)	Samples
THVD1410D	ACTIVE	SOIC	D	8	75	RoHS & Green	NIPDAU	Level-1-260C-UNLIM	-40 to 125	VD1410	Samples
THVD1410DGK	ACTIVE	VSSOP	DGK	8	80	RoHS & Green	NIPDAUAG	Level-1-260C-UNLIM	-40 to 125	1410	Samples
THVD1410DGKR	ACTIVE	VSSOP	DGK	8	2500	RoHS & Green	NIPDAUAG	Level-1-260C-UNLIM	-40 to 125	1410	Samples
THVD1410DR	ACTIVE	SOIC	D	8	2500	RoHS & Green	NIPDAU	Level-1-260C-UNLIM	-40 to 125	VD1410	Samples
THVD1450D	ACTIVE	SOIC	D	8	75	RoHS & Green	NIPDAU	Level-1-260C-UNLIM	-40 to 125	VD1450	Samples
THVD1450DGK	ACTIVE	VSSOP	DGK	8	80	RoHS & Green	NIPDAUAG	Level-1-260C-UNLIM	-40 to 125	1450	Samples
THVD1450DGKR	ACTIVE	VSSOP	DGK	8	2500	RoHS & Green	NIPDAUAG	Level-1-260C-UNLIM	-40 to 125	1450	Samples
THVD1450DR	ACTIVE	SOIC	D	8	2500	RoHS & Green	NIPDAU	Level-1-260C-UNLIM	-40 to 125	VD1450	Samples
THVD1450DRBR	ACTIVE	SON	DRB	8	3000	RoHS & Green	SN	Level-1-260C-UNLIM	-40 to 125	1450	Samples
THVD1450DRBT	ACTIVE	SON	DRB	8	250	RoHS & Green	SN	Level-1-260C-UNLIM	-40 to 125	1450	Samples
THVD1451D	ACTIVE	SOIC	D	8	75	RoHS & Green	NIPDAU	Level-1-260C-UNLIM	-40 to 125	VD1451	Samples
THVD1451DR	ACTIVE	SOIC	D	8	2500	RoHS & Green	NIPDAU	Level-1-260C-UNLIM	-40 to 125	VD1451	Samples
THVD1451DRBR	ACTIVE	SON	DRB	8	3000	RoHS & Green	SN	Level-1-260C-UNLIM	-40 to 125	1451	Samples
THVD1451DRBT	ACTIVE	SON	DRB	8	250	RoHS & Green	SN	Level-1-260C-UNLIM	-40 to 125	1451	Samples
THVD1452D	ACTIVE	SOIC	D	14	50	RoHS & Green	NIPDAU	Level-1-260C-UNLIM	-40 to 125	1452	Samples
THVD1452DGS	ACTIVE	VSSOP	DGS	10	80	RoHS & Green	NIPDAUAG	Level-1-260C-UNLIM	-40 to 125	1452	Samples
THVD1452DGSR	ACTIVE	VSSOP	DGS	10	2500	RoHS & Green	NIPDAUAG	Level-1-260C-UNLIM	-40 to 125	1452	Samples
THVD1452DR	ACTIVE	SOIC	D	14	2500	RoHS & Green	NIPDAU	Level-1-260C-UNLIM	-40 to 125	1452	Samples

⁽¹⁾ The marketing status values are defined as follows:

ACTIVE: Product device recommended for new designs.

LIFEBUY: TI has announced that the device will be discontinued, and a lifetime-buy period is in effect.

NRND: Not recommended for new designs. Device is in production to support existing customers, but TI does not recommend using this part in a new design.

PREVIEW: Device has been announced but is not in production. Samples may or may not be available.

OBSOLETE: TI has discontinued the production of the device.

⁽²⁾ **RoHS:** TI defines "RoHS" to mean semiconductor products that are compliant with the current EU RoHS requirements for all 10 RoHS substances, including the requirement that RoHS substance do not exceed 0.1% by weight in homogeneous materials. Where designed to be soldered at high temperatures, "RoHS" products are suitable for use in specified lead-free processes. TI may reference these types of products as "Pb-Free".

RoHS Exempt: TI defines "RoHS Exempt" to mean products that contain lead but are compliant with EU RoHS pursuant to a specific EU RoHS exemption.

Green: TI defines "Green" to mean the content of Chlorine (Cl) and Bromine (Br) based flame retardants meet JS709B low halogen requirements of ≤ 1000 ppm threshold. Antimony trioxide based flame retardants must also meet the ≤ 1000 ppm threshold requirement.

⁽³⁾ **MSL, Peak Temp.** - The Moisture Sensitivity Level rating according to the JEDEC industry standard classifications, and peak solder temperature.

⁽⁴⁾ There may be additional marking, which relates to the logo, the lot trace code information, or the environmental category on the device.

⁽⁵⁾ Multiple Device Markings will be inside parentheses. Only one Device Marking contained in parentheses and separated by a "~" will appear on a device. If a line is indented then it is a continuation of the previous line and the two combined represent the entire Device Marking for that device.

⁽⁶⁾ **Lead finish/Ball material** - Orderable Devices may have multiple material finish options. Finish options are separated by a vertical ruled line. Lead finish/Ball material values may wrap to two lines if the finish value exceeds the maximum column width.

Important Information and Disclaimer: The information provided on this page represents TI's knowledge and belief as of the date that it is provided. TI bases its knowledge and belief on information provided by third parties, and makes no representation or warranty as to the accuracy of such information. Efforts are underway to better integrate information from third parties. TI has taken and continues to take reasonable steps to provide representative and accurate information but may not have conducted destructive testing or chemical analysis on incoming materials and chemicals. TI and TI suppliers consider certain information to be proprietary, and thus CAS numbers and other limited information may not be available for release.

In no event shall TI's liability arising out of such information exceed the total purchase price of the TI part(s) at issue in this document sold by TI to Customer on an annual basis.

TAPE AND REEL INFORMATION

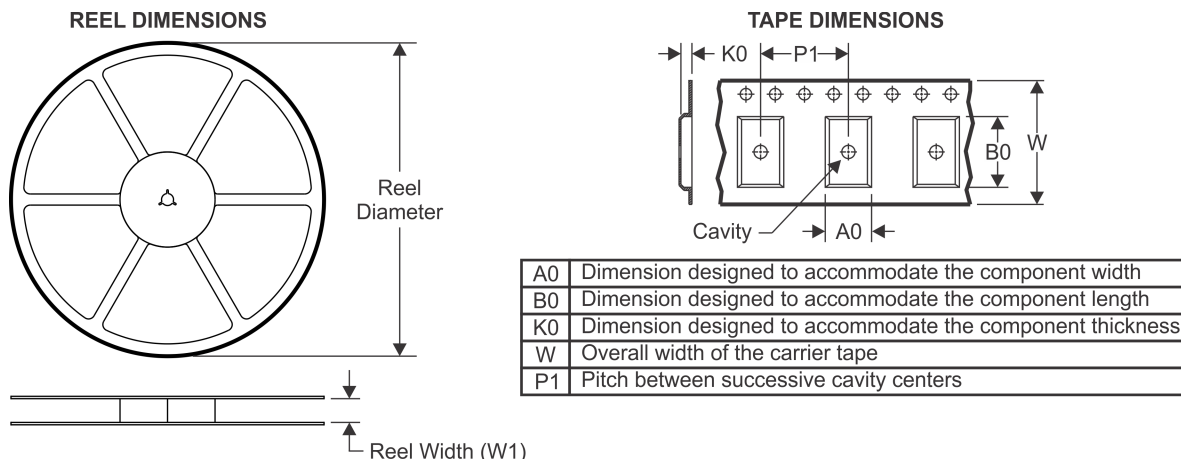

QUADRANT ASSIGNMENTS FOR PIN 1 ORIENTATION IN TAPE



*All dimensions are nominal

Device	Package Type	Package Drawing	Pins	SPQ	Reel Diameter (mm)	Reel Width W1 (mm)	A0 (mm)	B0 (mm)	K0 (mm)	P1 (mm)	W (mm)	Pin1 Quadrant
THVD1410DGKR	VSSOP	DGK	8	2500	330.0	12.4	5.3	3.4	1.4	8.0	12.0	Q1
THVD1410DR	SOIC	D	8	2500	330.0	12.4	6.4	5.2	2.1	8.0	12.0	Q1
THVD1450DGKR	VSSOP	DGK	8	2500	330.0	12.4	5.3	3.4	1.4	8.0	12.0	Q1
THVD1450DR	SOIC	D	8	2500	330.0	12.4	6.4	5.2	2.1	8.0	12.0	Q1
THVD1450DRBR	SON	DRB	8	3000	330.0	12.4	3.3	3.3	1.0	8.0	12.0	Q2
THVD1450DRBT	SON	DRB	8	250	180.0	12.4	3.3	3.3	1.0	8.0	12.0	Q2
THVD1451DR	SOIC	D	8	2500	330.0	12.4	6.4	5.2	2.1	8.0	12.0	Q1
THVD1451DRBR	SON	DRB	8	3000	330.0	12.4	3.3	3.3	1.0	8.0	12.0	Q2
THVD1451DRBT	SON	DRB	8	250	180.0	12.4	3.3	3.3	1.0	8.0	12.0	Q2
THVD1452DGSR	VSSOP	DGS	10	2500	330.0	12.4	5.3	3.4	1.4	8.0	12.0	Q1
THVD1452DR	SOIC	D	14	2500	330.0	16.4	6.5	9.0	2.1	8.0	16.0	Q1

TAPE AND REEL BOX DIMENSIONS

*All dimensions are nominal

Device	Package Type	Package Drawing	Pins	SPQ	Length (mm)	Width (mm)	Height (mm)
THVD1410DGKR	VSSOP	DGK	8	2500	364.0	364.0	27.0
THVD1410DR	SOIC	D	8	2500	340.5	336.1	25.0
THVD1450DGKR	VSSOP	DGK	8	2500	364.0	364.0	27.0
THVD1450DR	SOIC	D	8	2500	340.5	336.1	25.0
THVD1450DRBR	SON	DRB	8	3000	346.0	346.0	35.0
THVD1450DRBT	SON	DRB	8	250	200.0	183.0	25.0
THVD1451DR	SOIC	D	8	2500	340.5	336.1	25.0
THVD1451DRBR	SON	DRB	8	3000	346.0	346.0	35.0
THVD1451DRBT	SON	DRB	8	250	200.0	183.0	25.0
THVD1452DGSR	VSSOP	DGS	10	2500	364.0	364.0	27.0
THVD1452DR	SOIC	D	14	2500	340.5	336.1	32.0

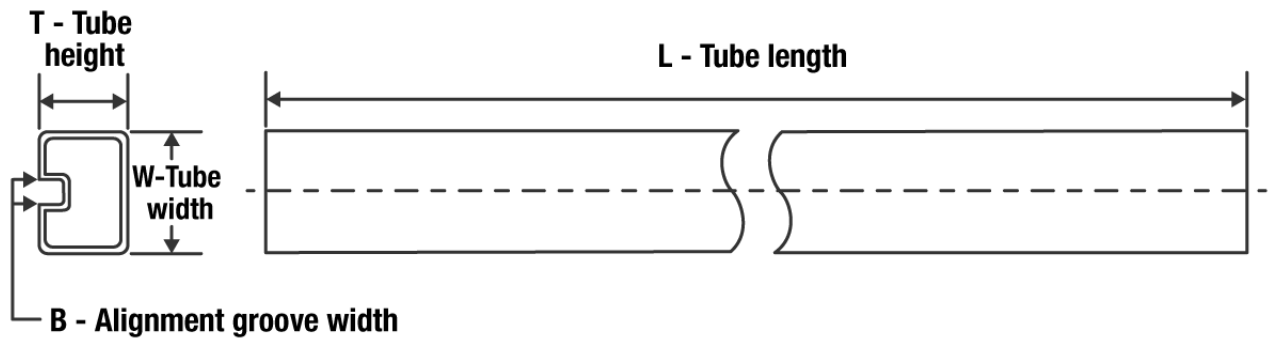
TUBE

*All dimensions are nominal

Device	Package Name	Package Type	Pins	SPQ	L (mm)	W (mm)	T (μm)	B (mm)
THVD1410D	D	SOIC	8	75	507	8	3940	4.32
THVD1410DGK	DGK	VSSOP	8	80	330	6.55	500	2.88
THVD1450D	D	SOIC	8	75	507	8	3940	4.32
THVD1450DGK	DGK	VSSOP	8	80	330	6.55	500	2.88
THVD1451D	D	SOIC	8	75	507	8	3940	4.32
THVD1452D	D	SOIC	14	50	507	8	3940	4.32
THVD1452DGS	DGS	VSSOP	10	80	330	6.55	500	2.88

DRB 8

GENERIC PACKAGE VIEW

VSON - 1 mm max height

PLASTIC SMALL OUTLINE - NO LEAD



Images above are just a representation of the package family, actual package may vary.
Refer to the product data sheet for package details.

4203482/L

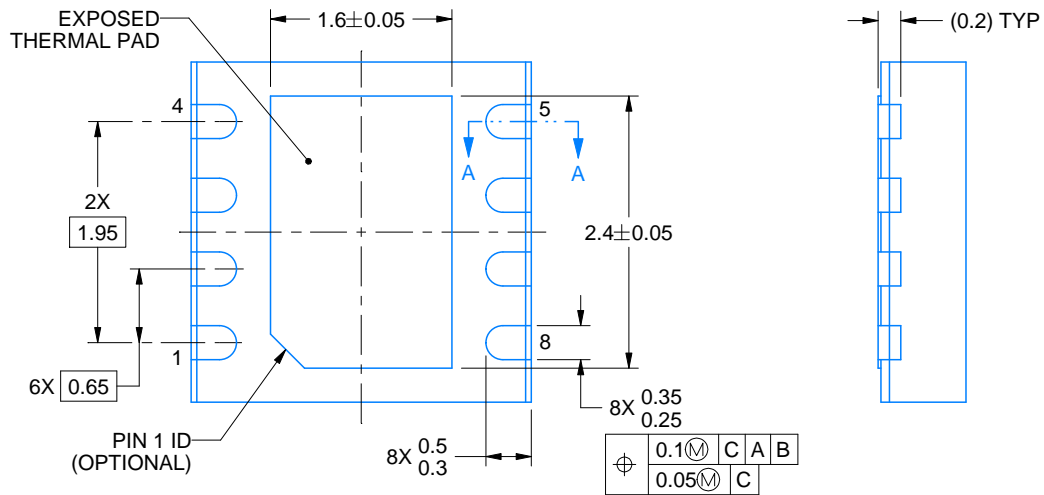
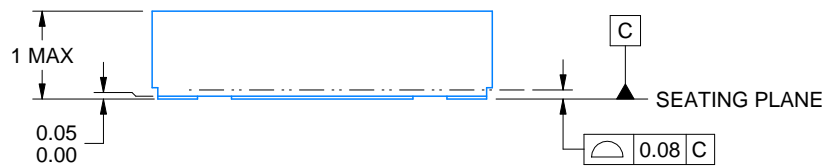
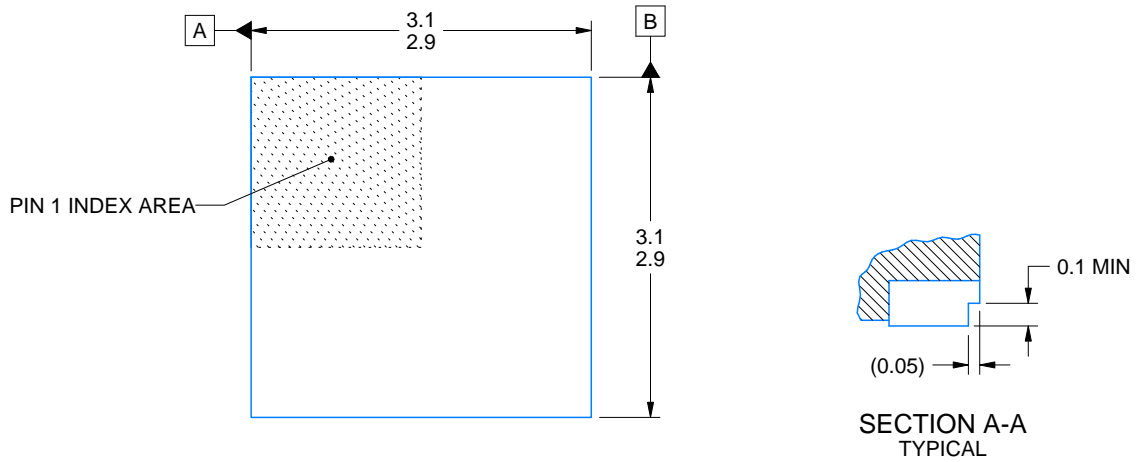

4222121/C 10/2016

NOTES:

1. All linear dimensions are in millimeters. Any dimensions in parenthesis are for reference only. Dimensioning and tolerancing per ASME Y14.5M.
2. This drawing is subject to change without notice.
3. The package thermal pad must be soldered to the printed circuit board for thermal and mechanical performance.

EXAMPLE BOARD LAYOUT

DRB0008F

VSON - 1 mm max height

PLASTIC SMALL OUTLINE - NO LEAD

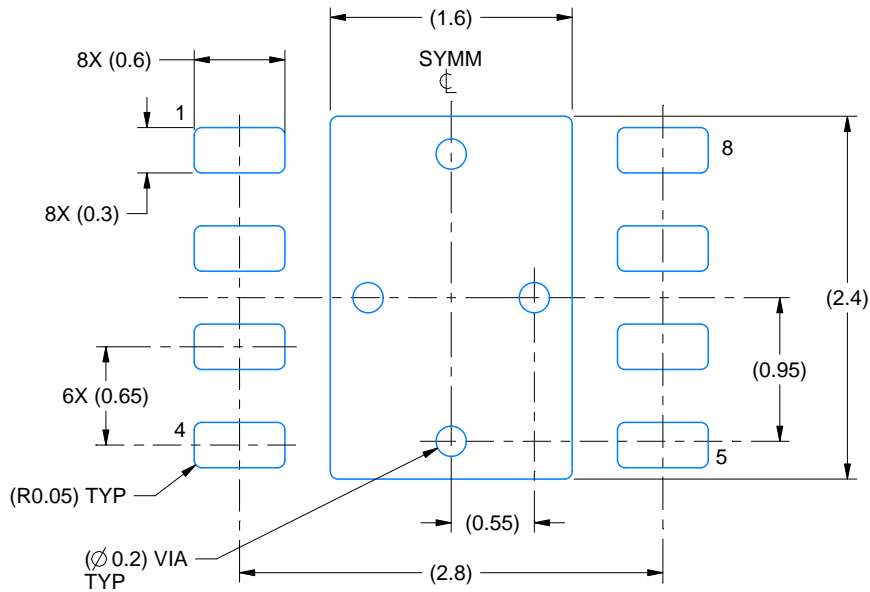

LAND PATTERN EXAMPLE
SCALE:20X

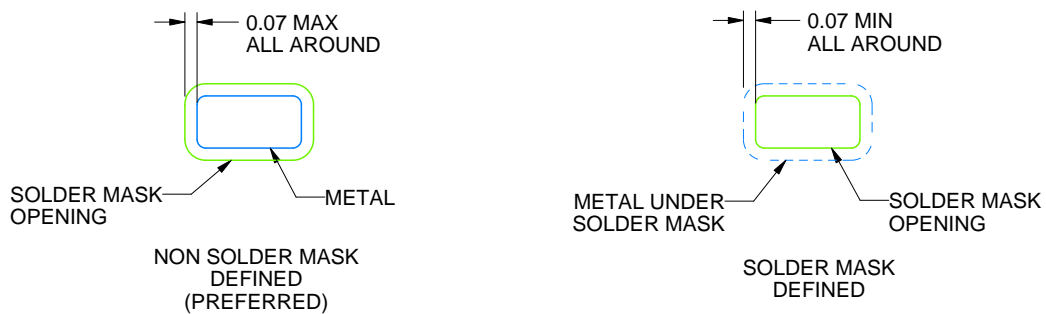

SOLDER MASK DETAILS

4222121/C 10/2016

NOTES: (continued)

4. This package is designed to be soldered to a thermal pad on the board. For more information, see Texas Instruments literature number SLUA271 (www.ti.com/lit/sluea271).
5. Vias are optional depending on application, refer to device data sheet. If any vias are implemented, refer to their locations shown on this view. It is recommended that vias under paste be filled, plugged or tented.

EXAMPLE STENCIL DESIGN

DRB0008F

VSON - 1 mm max height

PLASTIC SMALL OUTLINE - NO LEAD

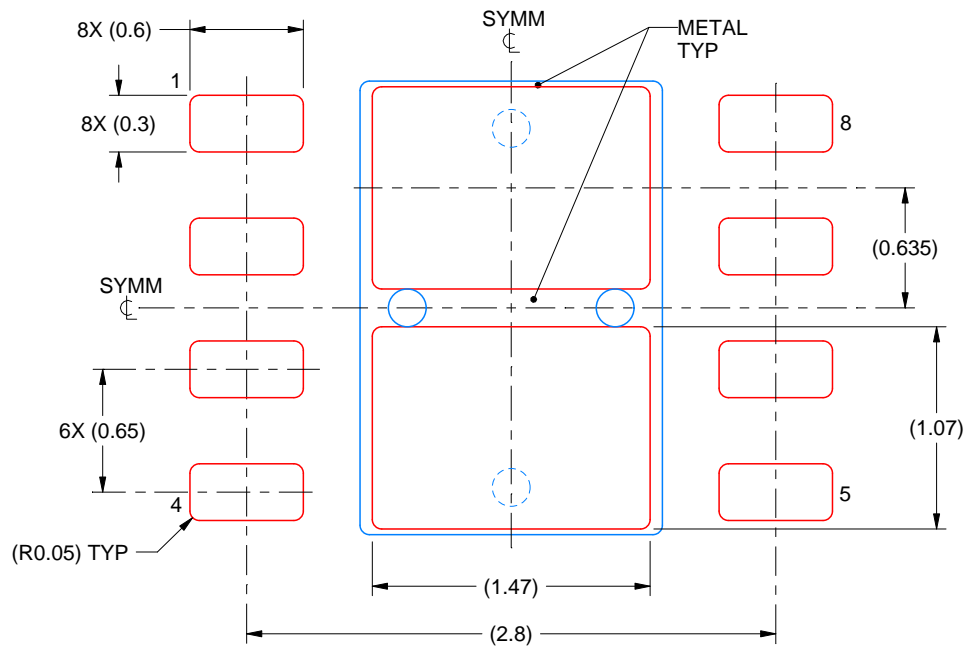

SOLDER PASTE EXAMPLE
BASED ON 0.125 mm THICK STENCIL

EXPOSED PAD
82% PRINTED SOLDER COVERAGE BY AREA
SCALE:25X

4222121/C 10/2016

NOTES: (continued)

6. Laser cutting apertures with trapezoidal walls and rounded corners may offer better paste release. IPC-7525 may have alternate design recommendations.

DGS0010A

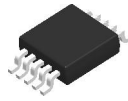

PACKAGE OUTLINE

VSSOP - 1.1 mm max height

SMALL OUTLINE PACKAGE

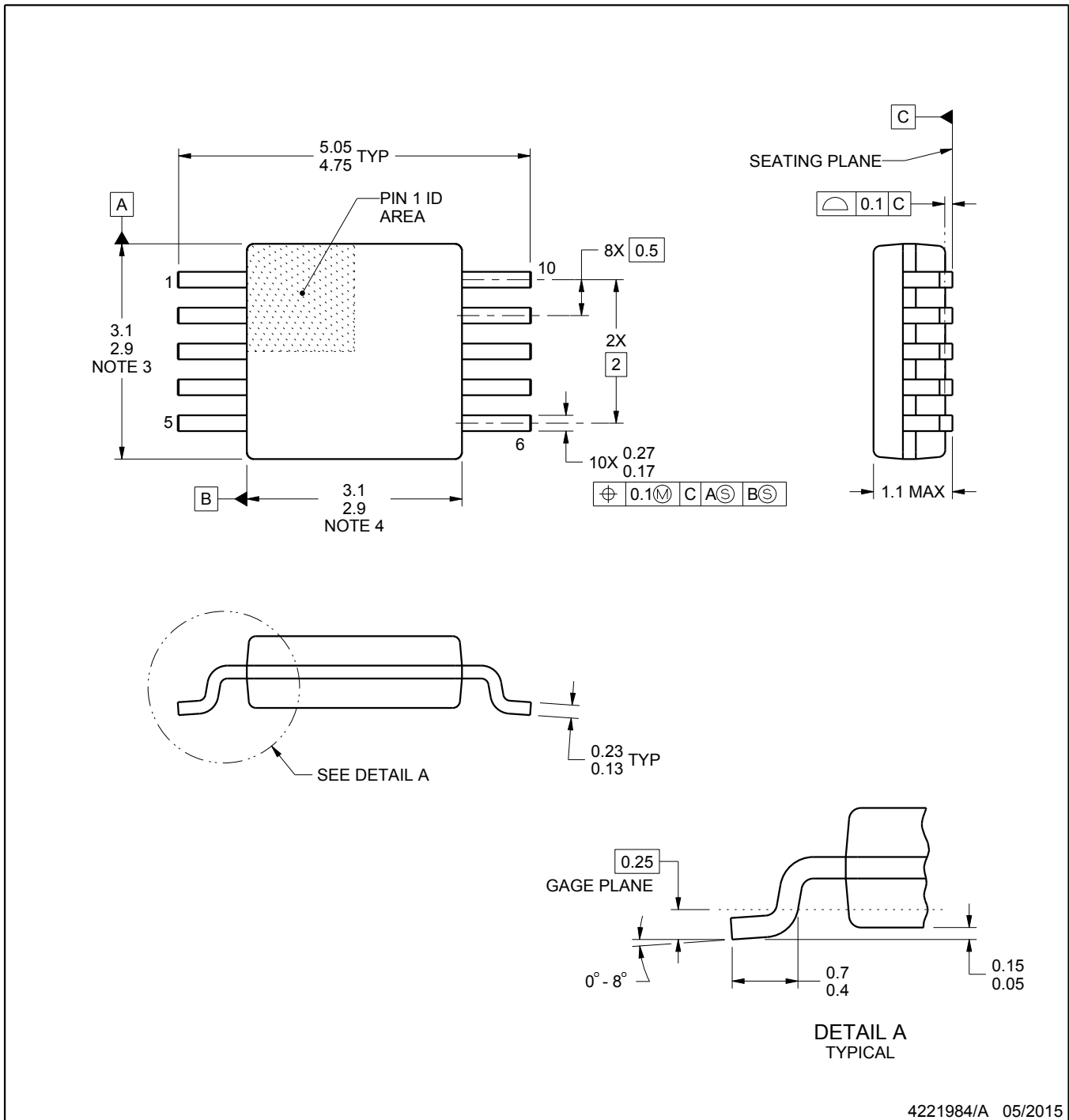

4221984/A 05/2015

NOTES:

1. All linear dimensions are in millimeters. Any dimensions in parenthesis are for reference only. Dimensioning and tolerancing per ASME Y14.5M.
2. This drawing is subject to change without notice.
3. This dimension does not include mold flash, protrusions, or gate burrs. Mold flash, protrusions, or gate burrs shall not exceed 0.15 mm per side.
4. This dimension does not include interlead flash. Interlead flash shall not exceed 0.25 mm per side.
5. Reference JEDEC registration MO-187, variation BA.

EXAMPLE BOARD LAYOUT

DGS0010A

VSSOP - 1.1 mm max height

SMALL OUTLINE PACKAGE

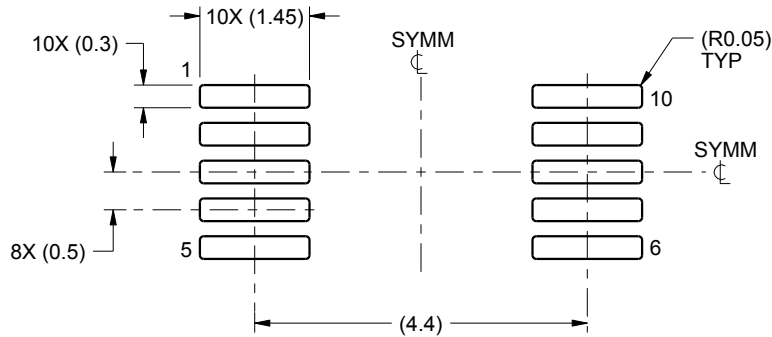

LAND PATTERN EXAMPLE
SCALE:10X

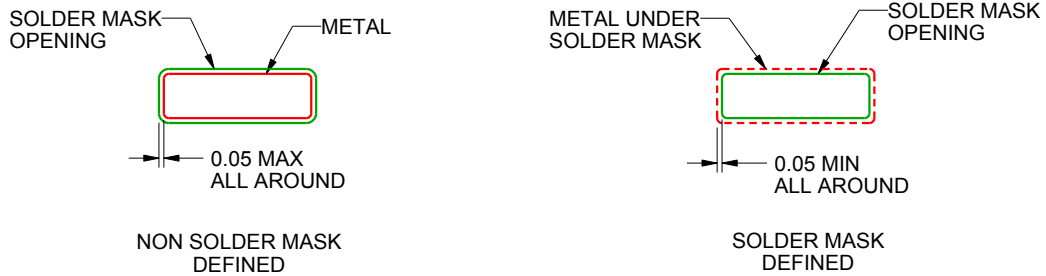

SOLDER MASK DETAILS
NOT TO SCALE

4221984/A 05/2015

NOTES: (continued)

- 6. Publication IPC-7351 may have alternate designs.
- 7. Solder mask tolerances between and around signal pads can vary based on board fabrication site.

EXAMPLE STENCIL DESIGN

DGS0010A

VSSOP - 1.1 mm max height

SMALL OUTLINE PACKAGE

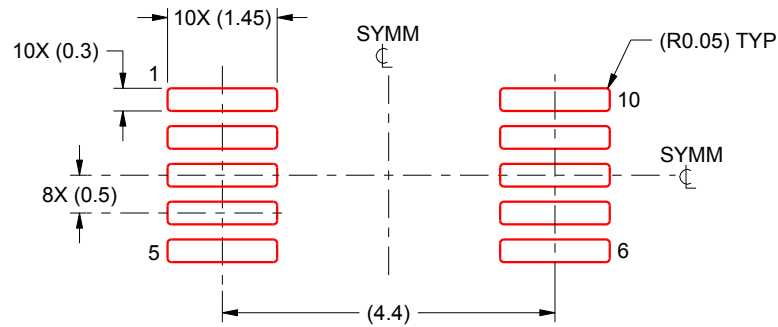

SOLDER PASTE EXAMPLE
BASED ON 0.125 mm THICK STENCIL
SCALE:10X

4221984/A 05/2015

NOTES: (continued)

8. Laser cutting apertures with trapezoidal walls and rounded corners may offer better paste release. IPC-7525 may have alternate design recommendations.
9. Board assembly site may have different recommendations for stencil design.

D (R-PDSO-G14)

PLASTIC SMALL OUTLINE

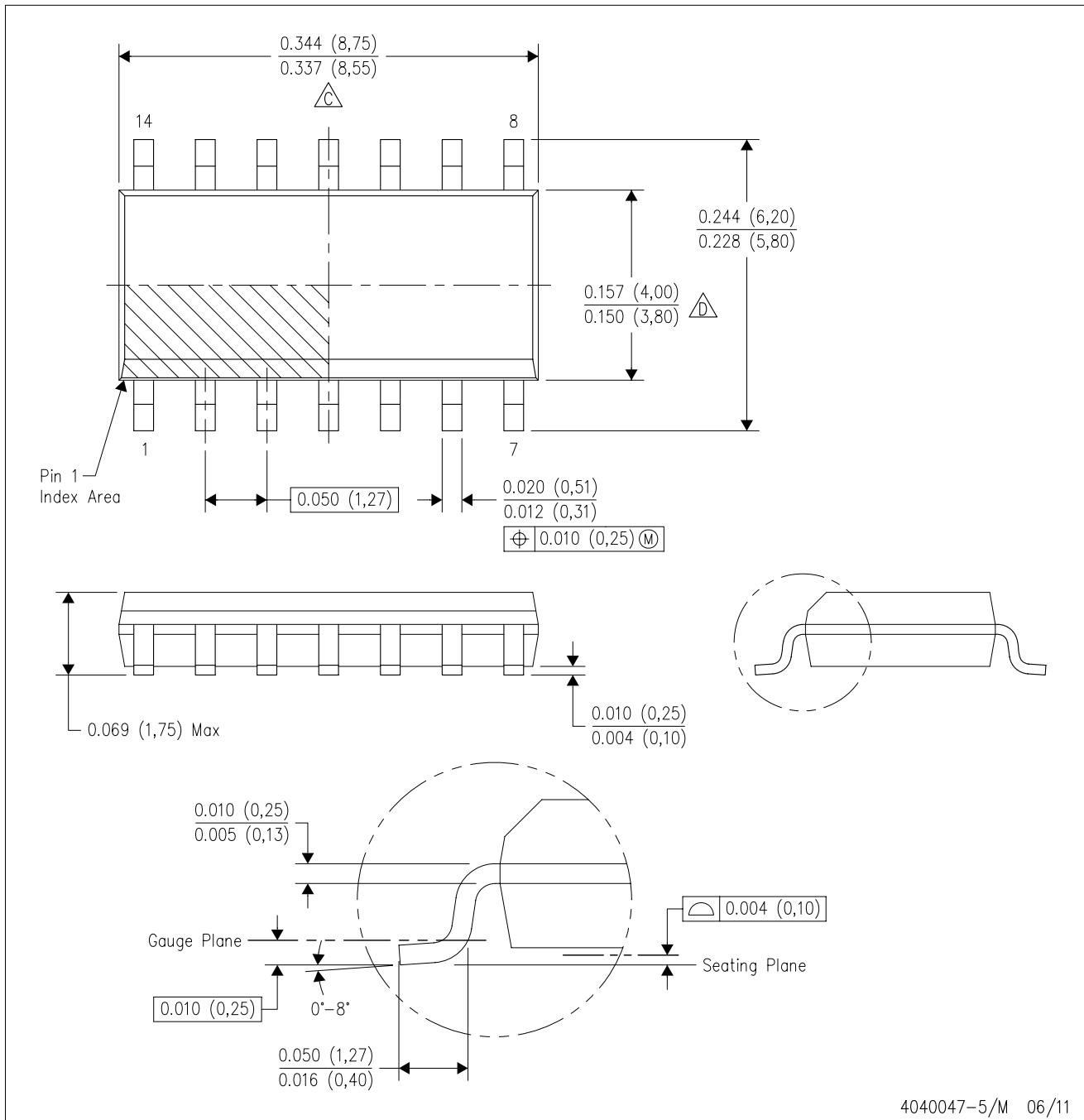

- NOTES:
- A. All linear dimensions are in inches (millimeters).
 - B. This drawing is subject to change without notice.
 - Body length does not include mold flash, protrusions, or gate burrs. Mold flash, protrusions, or gate burrs shall not exceed 0.006 (0,15) each side.
 - Body width does not include interlead flash. Interlead flash shall not exceed 0.017 (0,43) each side.
 - E. Reference JEDEC MS-012 variation AB.

D (R-PDSO-G14)

PLASTIC SMALL OUTLINE



4211283-3/E 08/12

- NOTES:
- A. All linear dimensions are in millimeters.
 - B. This drawing is subject to change without notice.
 - C. Publication IPC-7351 is recommended for alternate designs.
 - D. Laser cutting apertures with trapezoidal walls and also rounding corners will offer better paste release. Customers should contact their board assembly site for stencil design recommendations. Refer to IPC-7525 for other stencil recommendations.
 - E. Customers should contact their board fabrication site for solder mask tolerances between and around signal pads.



D0008A

PACKAGE OUTLINE

SOIC - 1.75 mm max height

SMALL OUTLINE INTEGRATED CIRCUIT



4214825/C 02/2019

NOTES:

- Linear dimensions are in inches [millimeters]. Dimensions in parenthesis are for reference only. Controlling dimensions are in inches. Dimensioning and tolerancing per ASME Y14.5M.
- This drawing is subject to change without notice.
- This dimension does not include mold flash, protrusions, or gate burrs. Mold flash, protrusions, or gate burrs shall not exceed .006 [0.15] per side.
- This dimension does not include interlead flash.
- Reference JEDEC registration MS-012, variation AA.

EXAMPLE BOARD LAYOUT

D0008A

SOIC - 1.75 mm max height

SMALL OUTLINE INTEGRATED CIRCUIT



LAND PATTERN EXAMPLE
 EXPOSED METAL SHOWN
 SCALE:8X



SOLDER MASK DETAILS

4214825/C 02/2019

NOTES: (continued)

- 6. Publication IPC-7351 may have alternate designs.
- 7. Solder mask tolerances between and around signal pads can vary based on board fabrication site.

EXAMPLE STENCIL DESIGN

D0008A

SOIC - 1.75 mm max height

SMALL OUTLINE INTEGRATED CIRCUIT



SOLDER PASTE EXAMPLE
BASED ON .005 INCH [0.125 MM] THICK STENCIL
SCALE:8X

4214825/C 02/2019

NOTES: (continued)

8. Laser cutting apertures with trapezoidal walls and rounded corners may offer better paste release. IPC-7525 may have alternate design recommendations.
9. Board assembly site may have different recommendations for stencil design.

DGK (S-PDSO-G8)

PLASTIC SMALL-OUTLINE PACKAGE

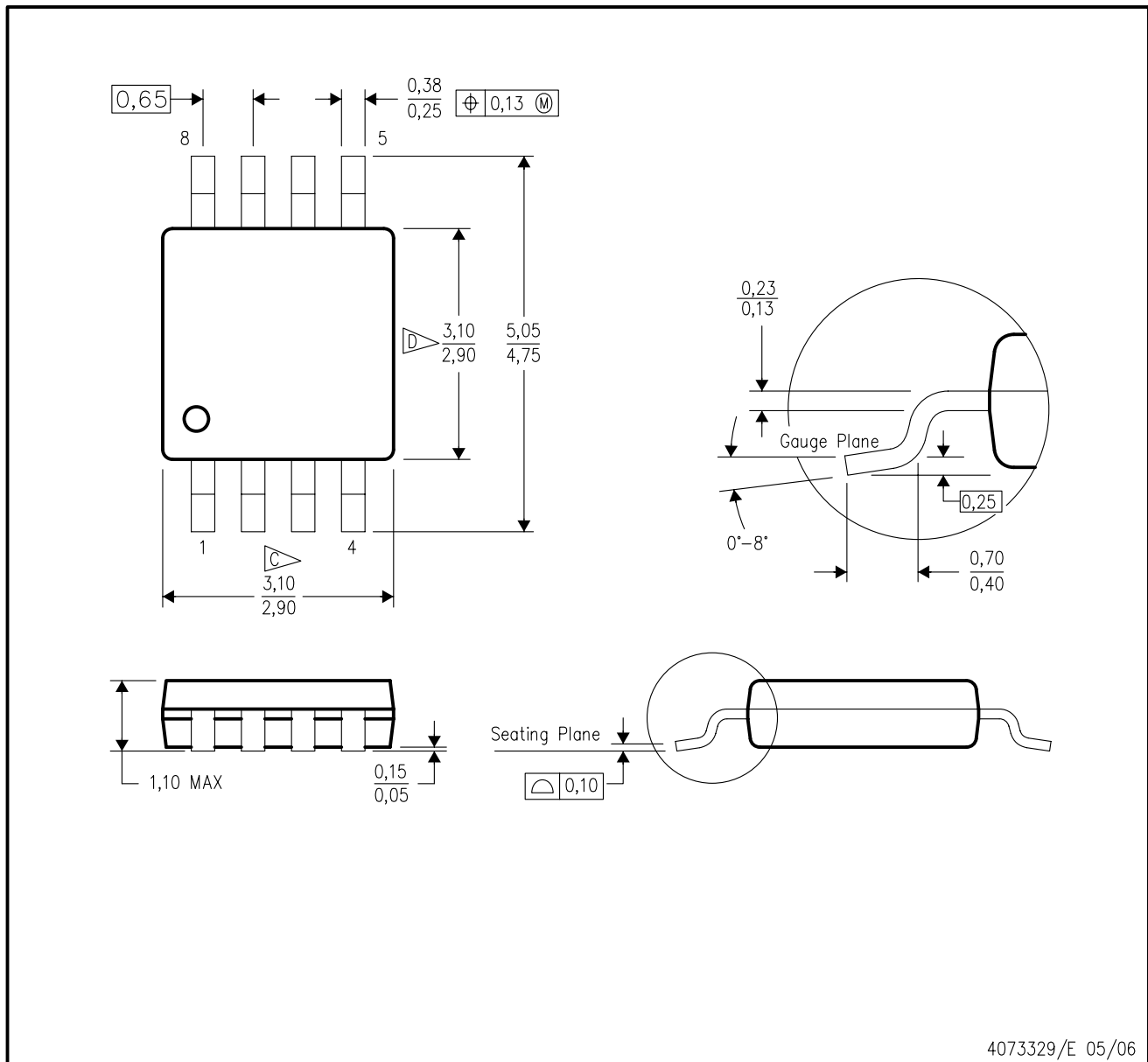

4073329/E 05/06

- NOTES:
- A. All linear dimensions are in millimeters.
 - B. This drawing is subject to change without notice.
 - C. Body length does not include mold flash, protrusions, or gate burrs. Mold flash, protrusions, or gate burrs shall not exceed 0.15 per end.
 - D. Body width does not include interlead flash. Interlead flash shall not exceed 0.50 per side.
 - E. Falls within JEDEC MO-187 variation AA, except interlead flash.

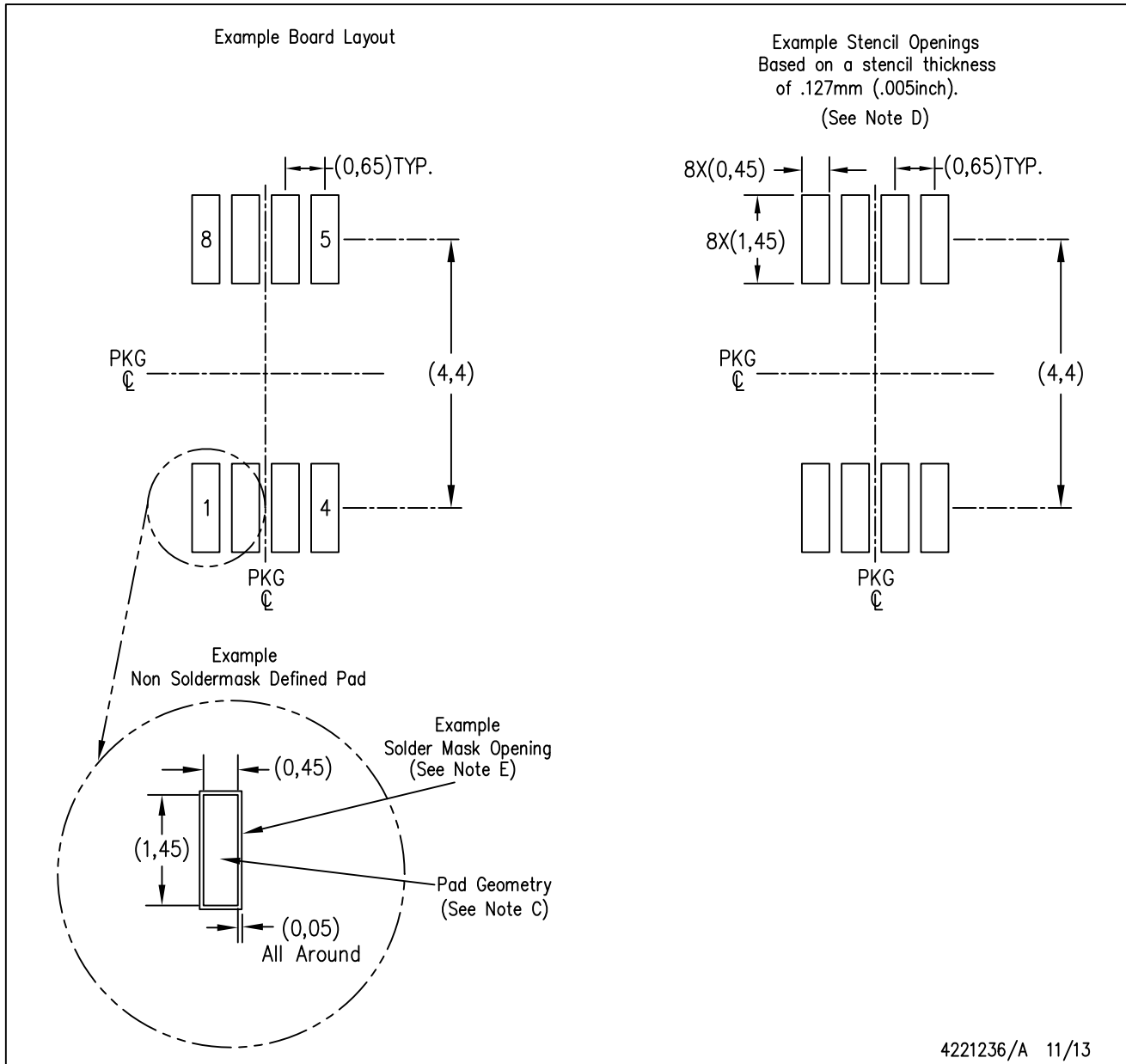

- NOTES:
- A. All linear dimensions are in millimeters.
 - B. This drawing is subject to change without notice.
 - C. Publication IPC-7351 is recommended for alternate designs.
 - D. Laser cutting apertures with trapezoidal walls and also rounding corners will offer better paste release. Customers should contact their board assembly site for stencil design recommendations. Refer to IPC-7525 for other stencil recommendations.
 - E. Customers should contact their board fabrication site for solder mask tolerances between and around signal pads.

IMPORTANT NOTICE AND DISCLAIMER

TI PROVIDES TECHNICAL AND RELIABILITY DATA (INCLUDING DATA SHEETS), DESIGN RESOURCES (INCLUDING REFERENCE DESIGNS), APPLICATION OR OTHER DESIGN ADVICE, WEB TOOLS, SAFETY INFORMATION, AND OTHER RESOURCES "AS IS" AND WITH ALL FAULTS, AND DISCLAIMS ALL WARRANTIES, EXPRESS AND IMPLIED, INCLUDING WITHOUT LIMITATION ANY IMPLIED WARRANTIES OF MERCHANTABILITY, FITNESS FOR A PARTICULAR PURPOSE OR NON-INFRINGEMENT OF THIRD PARTY INTELLECTUAL PROPERTY RIGHTS.

These resources are intended for skilled developers designing with TI products. You are solely responsible for (1) selecting the appropriate TI products for your application, (2) designing, validating and testing your application, and (3) ensuring your application meets applicable standards, and any other safety, security, regulatory or other requirements.

These resources are subject to change without notice. TI grants you permission to use these resources only for development of an application that uses the TI products described in the resource. Other reproduction and display of these resources is prohibited. No license is granted to any other TI intellectual property right or to any third party intellectual property right. TI disclaims responsibility for, and you will fully indemnify TI and its representatives against, any claims, damages, costs, losses, and liabilities arising out of your use of these resources.

TI's products are provided subject to [TI's Terms of Sale](#) or other applicable terms available either on ti.com or provided in conjunction with such TI products. TI's provision of these resources does not expand or otherwise alter TI's applicable warranties or warranty disclaimers for TI products.

TI objects to and rejects any additional or different terms you may have proposed.

Mailing Address: Texas Instruments, Post Office Box 655303, Dallas, Texas 75265
Copyright © 2022, Texas Instruments Incorporated