

# LM21305 3-V to 18-V, 5-A, Adjustable Frequency Synchronous Buck Converter

## 1 Features

- High-Efficiency Synchronous DC-DC Converter:
  - Integrated Low  $R_{DS(on)}$  Power MOSFETs
  - Wide Input Voltage Range: 3 V to 18 V
  - Load Current as High as 5 A
  - Switching Frequency: 300 kHz to 1.5 MHz
- External Frequency Synchronization
- Accurate 0.598-V Feedback Voltage Reference
- Ultra-Fast Line and Load Transient Response:
  - Peak Current-Mode Control
  - Internal Slope Compensation
  - High-Bandwidth Error Amplifier
- Ultra-Low Shutdown Quiescent Current
- Wide Duty-Cycle Operating Range:
  - $T_{ON-MIN}$ : 70 ns for Low  $V_{OUT}$
  - $T_{OFF-MIN}$ : 50 ns for High Duty Cycle
- Diode Emulation Mode at Light Loads
- Integrated Bias Supply LDO Sub-Regulators
- Internal Soft-Start Function:
  - Monotonic Startup into Pre-Biased Loads
- Precision Enable Input with Hysteresis
- Open-Drain PGOOD Indicator
- Internal Input Undervoltage Lockout (UVLO)
- Cycle-by-Cycle Overcurrent Protection
- Output Overvoltage Protection (OVP)
- Thermal Shutdown Protection with Hysteresis
- 5-mm x 5-mm WQFN-28 PowerPAD™ Package

## 2 Applications

- DC-DC Converters and POL Modules
- DSP and FPGA Core Voltage Supplies
- Telecommunications Infrastructure
- Embedded Computing, Servers, and Storage

## 3 Description

The LM21305 is a full-featured, 5-A, synchronous buck dc-dc converter optimized for solution size, flexibility, and high conversion efficiency. High-power density LM21305 designs are easily achieved by virtue of monolithic integration of high-side and low-side power MOSFETs, high switching frequency, peak current-mode control, and optimized thermal design. The efficiency of the LM21305 is maximized at light loads with diode emulation mode operation and at heavy loads by optimal design of the MOSFET adaptive gate drivers to minimize switch dead-times and body-diode conduction losses.

The LM21305 accepts a wide input voltage range of 3 V to 18 V for interface to various intermediate bus voltages, including 3.3-V, 5-V, and 12-V rails. A 1.5% voltage reference and 70-ns, high-side MOSFET minimum controllable on-time enable output voltages as low as 0.598 V with excellent setpoint accuracy. The LM21305 is available in a 5-mm x 5-mm<sup>2</sup> WQFN-28 thermally-enhanced package with 0.5-mm pitch.

### Device Information<sup>(1)</sup>

PART NUMBER	PACKAGE	BODY SIZE (NOM)
LM21305	WQFN (28)	5.00 mm x 5.00 mm

(1) For all available packages, see the orderable addendum at the end of the data sheet.

### Typical Application Circuit

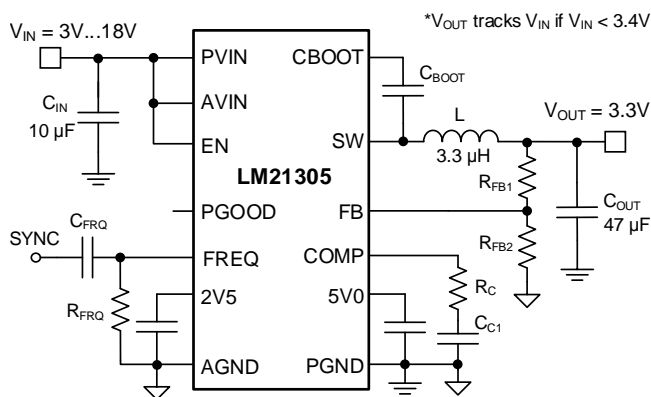

### Typical Efficiency at 12 V, 500 kHz

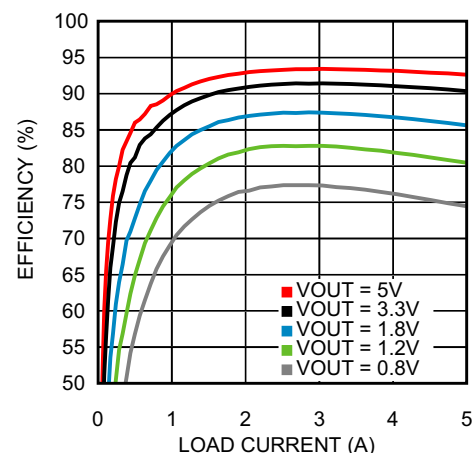

## Table of Contents

<b>1 Features</b> .....	<b>1</b>	8.4 Device Functional Modes.....	<b>17</b>
<b>2 Applications</b> .....	<b>1</b>	<b>9 Application and Implementation</b> .....	<b>18</b>
<b>3 Description</b> .....	<b>1</b>	9.1 Application Information.....	<b>18</b>
<b>4 Revision History</b> .....	<b>2</b>	9.2 Typical Application .....	<b>18</b>
<b>5 Description (continued)</b> .....	<b>3</b>	<b>10 Power Supply Recommendations</b> .....	<b>30</b>
<b>6 Pin Configuration and Functions</b> .....	<b>3</b>	<b>11 Layout</b> .....	<b>31</b>
<b>7 Specifications</b> .....	<b>5</b>	11.1 Layout Guidelines .....	<b>31</b>
7.1 Absolute Maximum Ratings .....	<b>5</b>	11.2 Layout Example .....	<b>33</b>
7.2 ESD Ratings.....	<b>5</b>	<b>12 Device and Documentation Support</b> .....	<b>34</b>
7.3 Recommended Operating Conditions.....	<b>5</b>	12.1 Device Support .....	<b>34</b>
7.4 Thermal Information .....	<b>6</b>	12.2 Documentation Support .....	<b>34</b>
7.5 Electrical Characteristics .....	<b>6</b>	12.3 Community Resources.....	<b>34</b>
7.6 Typical Characteristics.....	<b>8</b>	12.4 Trademarks .....	<b>34</b>
<b>8 Detailed Description</b> .....	<b>11</b>	12.5 Electrostatic Discharge Caution.....	<b>35</b>
8.1 Overview .....	<b>11</b>	12.6 Glossary .....	<b>35</b>
8.2 Functional Block Diagram .....	<b>11</b>	<b>13 Mechanical, Packaging, and Orderable Information</b> .....	<b>35</b>
8.3 Feature Description.....	<b>12</b>		

## 4 Revision History

NOTE: Page numbers for previous revisions may differ from page numbers in the current version.

<b>Changes from Revision F (March 2013) to Revision G</b>	<b>Page</b>
• Changed <i>Features</i> , <i>Applications</i> , and <i>Description</i> sections and page 1 graphics .....	<b>1</b>
• Added <i>Feature Description</i> section, <i>ESD Ratings</i> table, <i>Device Functional Modes</i> section, <i>Application and Implementation</i> section, <i>Power Supply Recommendations</i> section, <i>Layout</i> section, <i>Device and Documentation Support</i> section, and <i>Mechanical, Packaging, and Orderable Information</i> section. ....	<b>1</b>
• Changed <i>Precision Enable</i> section.....	<b>15</b>

## 5 Description (continued)

The LM21305 offers flexible system configuration with programmable switching frequency from 300 kHz to 1.5 MHz using one resistor or by external clock synchronization for beat-frequency-sensitive and multi-regulator applications. On-chip bias supply low-dropout (LDO) sub-regulators eliminate the need for an external bias power and simplify circuit board layout. The device also offers an internal soft-start to limit inrush current and provide monotonic startup capability into unbiased and pre-biased loads, integrated boot diodes, cycle-by-cycle current limiting, and thermal shutdown. Peak current-mode control with a high-gain error amplifier maintains stability throughout the entire input voltage and load current ranges, enabling excellent line and load transient response.

The LM21305 features internal output overvoltage protection (OVP) and overcurrent protection (OCP) circuits for increased system reliability. An integrated open-drain, PGOOD indicator provides output voltage monitoring, power-rail sequencing capability, and fault indication. Other features include thermal shutdown with automatic recovery, low PWM minimum on-time, low shutdown quiescent current, and precision enable with hysteresis for programmable line undervoltage lockout (UVLO).

## 6 Pin Configuration and Functions

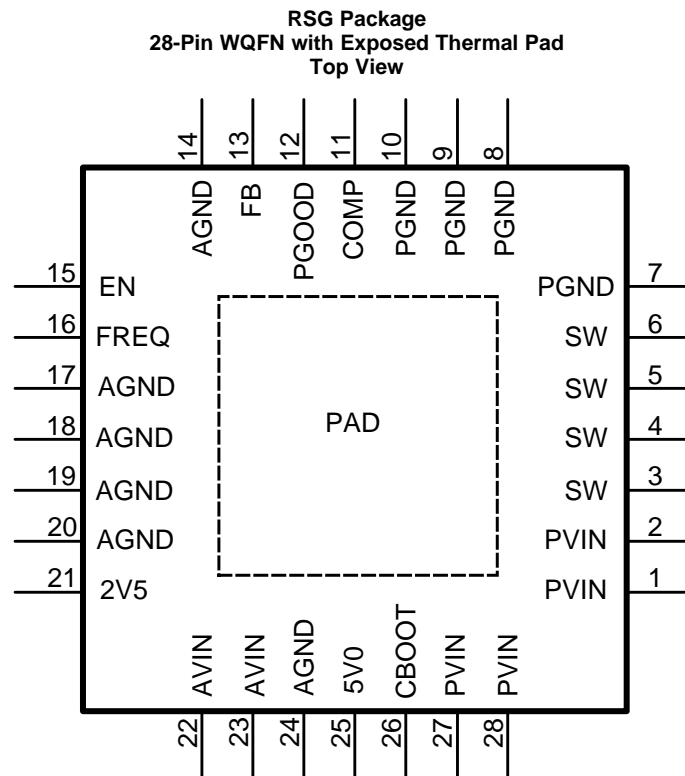

### Pin Functions

PIN		Type <sup>(1)</sup>	DESCRIPTION
NAME	NO.		
2V5	21	P	2.5-V output of the internal LDO regulator. Bypass to AGND with a 0.1- $\mu$ F ceramic capacitor. Loading this pin is not recommended.
5V0	25	P	5.0-V output of the internal LDO regulator. Bypass to PGND with a 1- $\mu$ F ceramic capacitor. Loading this pin is not recommended.
AGND	14, 17–20, 24	G	Analog ground for the internal bias circuitry and signal return connection for analog functions, including COMP network, frequency adjust resistor, and 2V5 decoupling capacitor.
AVIN	22, 23	P	Analog power input. AVIN powers the internal 2.5-V and 5.0-V LDOs that provide bias current and internal driver power, respectively. AVIN can be connected to PVIN through a low-pass RC filter or can be supplied by a separate rail.
CBOOT	26	P	High-side bootstrap connection to drive the high-side MOSFET. Connect a 100-nF bootstrap capacitor between the CBOOT and SW pins.
COMP	11	A	Compensation node. This pin is an output voltage control loop error amplifier output. Connect an external compensation network to ensure stability.
EN	15	I	Precision enable pin. Use an external divider to set the device turn-on threshold. If not used, connect the EN pin to AVIN.
FB	13	A	Voltage feedback pin. Connect this pin to the output voltage directly or through a resistor divider to set the output voltage range.
FREQ	16	A	Frequency adjust pin. Connect a resistor from FREQ to AGND to set the internal oscillator frequency. Connect FREQ to an external clock source via a coupling capacitor to synchronize to the external clock frequency.
PVIN	1, 2, 27, 28	P	Input voltage to the power MOSFETs inside the device.
SW	3-6	P	Switch node output of the power MOSFETs. Voltage swings from PVIN to GND on this pin. SW also delivers current to the external inductor.
PGND	7–10	G	Power ground connection for the internal power switches.
PGOOD	12	OD	Open-drain output with 16 $\mu$ s of built-in deglitch time. If high, this status pin indicates that the output voltage is regulated within tolerance. Connect a 10-k $\Omega$ to 100-k $\Omega$ resistor to a pullup voltage source, for example the 5V0 rail or auxiliary system voltage rail.
PAD	PAD	—	Exposed pad at the back of the device. Connect PAD to PGND, but PAD cannot be used as the primary ground connection. Use multiple vias under PAD to connect to the system ground plane for optimal thermal performance.

(1) P: Power, A: Analog, I: Digital Input, OD: Open Drain, G: Ground.

## 7 Specifications

### 7.1 Absolute Maximum Ratings

see <sup>(1)(2)</sup>

	MIN	MAX	UNIT
PVIN, AVIN, SW, EN, PGOOD to AGND	-0.3	20	V
CBOOT to AGND	-0.3	25	V
CBOOT to SW	-0.3	5.5	V
5V0, FB, COMP, FREQ to AGND	-0.3	6	V
2V5 to AGND	-0.3	3	V
AGND to PGND	-0.3	0.3	V
Maximum continuous power dissipation, $P_{D-MAX}$ <sup>(3)</sup>	Internally limited		
Junction temperature, $T_{J-MAX}$		150	°C
Storage temperature, $T_{stg}$	-65	150	°C

- Stresses beyond those listed under absolute maximum ratings may cause permanent damage to the device. These are stress ratings only, and functional operation of the device at these or any other conditions beyond those indicated under recommended operating conditions is not implied. Exposure to absolute-maximum-rated conditions for extended periods may affect device reliability.
- If Military or Aerospace specified devices are required, please contact the Texas Instruments Sales Office/Distributors for availability and specifications.
- The amount of absolute maximum power dissipation allowed in the device depends on the ambient temperature and can be calculated using the formula  $P = (T_J - T_A) / \theta_{JA}$ , where  $T_J$  is the junction temperature,  $T_A$  is the ambient temperature, and  $\theta_{JA}$  is the junction-to-ambient thermal resistance. Junction-to-ambient thermal resistance is highly application and board-layout dependent. In applications where high power dissipation exists, special care must be paid to thermal dissipation issues in PCB design. Internal thermal shutdown circuitry protects the device from permanent damage.

### 7.2 ESD Ratings

		VALUE	UNIT
$V_{(ESD)}$	Electrostatic discharge	Human body model (HBM), per ANSI/ESDA/JEDEC JS-001 <sup>(1)(2)</sup>	V
		Charged device model (CDM), per JEDEC specification JESD22-C101 <sup>(3)</sup>	
		±2000	
		±500	

- JEDEC document JEP155 states that 500-V HBM allows safe manufacturing with a standard ESD control process. Manufacturing with less than 500-V HBM is possible with the necessary precautions. Pins listed as ±2000 V may actually have higher performance.
- The human body model is a 100-pF capacitor discharged through a 1.5-kΩ resistor into each pin (MIL-STD-883 3015.7).
- JEDEC document JEP157 states that 250-V CDM allows safe manufacturing with a standard ESD control process. Manufacturing with less than 250-V CDM is possible with the necessary precautions. Pins listed as ±500 V may actually have higher performance.

### 7.3 Recommended Operating Conditions

	MIN	MAX	UNIT
PVIN to PGND, AGND	3	18	V
AVIN to PGND, AGND	3	18	V
Junction temperature	-40	125	°C
Ambient temperature <sup>(1)</sup>	-40	85	°C

- In applications where high power dissipation or poor package thermal resistance is present, the maximum ambient temperature may have to be derated. Maximum ambient temperature ( $T_{A-MAX}$ ) is dependent on the maximum operating junction temperature ( $T_{J-MAX-OP} = 125^{\circ}\text{C}$ ), the maximum power dissipation of the device in the application ( $P_{D-MAX}$ ), and the junction-to ambient thermal resistance of the part or package in the application ( $\theta_{JA}$ ), as given by the following equation:  $T_{A-MAX} = T_{J-MAX-OP} - (\theta_{JA} \times P_{D-MAX})$ .

## 7.4 Thermal Information

THERMAL METRIC <sup>(1)</sup>		LM21305	UNIT
		RSG (WQFN)	
		28 PINS	
R <sub>θJA</sub>	Junction-to-ambient thermal resistance	36.9	°C/W
R <sub>θJC(top)</sub>	Junction-to-case (top) thermal resistance	22	°C/W
R <sub>θJB</sub>	Junction-to-board thermal resistance	9.9	°C/W
ψ <sub>JT</sub>	Junction-to-top characterization parameter	0.2	°C/W
ψ <sub>JB</sub>	Junction-to-board characterization parameter	9.8	°C/W
R <sub>θJC(bot)</sub>	Junction-to-case (bottom) thermal resistance	2.1	°C/W

(1) For more information about traditional and new thermal metrics, see the *Semiconductor and IC Package Thermal Metrics* application report, [SPRA953](#).

## 7.5 Electrical Characteristics

All typical limits apply for T<sub>J</sub> = 25°C, and all maximum and minimum limits apply over the full operating temperature range (T<sub>J</sub> = –40°C to +125°C). Unless otherwise specified, V<sub>IN</sub> = V<sub>PVIN</sub> = V<sub>AVIN</sub> = 12 V, V<sub>OUT</sub> = 3.3 V, I<sub>OUT</sub> = 0 A.<sup>(1)(2)(2)</sup>

PARAMETER		TEST CONDITIONS	MIN	TYP	MAX	UNIT
<b>GENERAL</b>						
V <sub>FB-default</sub>	Feedback pin factory-default voltage		0.588	0.598	0.608	V
ΔV <sub>OUT</sub> /ΔI <sub>OUT</sub>	Load regulation	I <sub>OUT</sub> = 0.1 A to 5 A		0.02		%/A
ΔV <sub>OUT</sub> /ΔV <sub>IN</sub>	Line regulation	V <sub>PVIN</sub> = 3 V to 18 V		0.01		%/V
R <sub>DSonHS</sub>	High-side switch on-resistance	I <sub>DS</sub> = 5 A		44		mΩ
R <sub>DSonLS</sub>	Low-side switch on-resistance	I <sub>DS</sub> = 5 A		22		mΩ
I <sub>CL-HS</sub>	High-side switch current limit	High-side MOSFET	5.9	7	7.87	A
I <sub>CL-LS</sub>	Low-side switch current limit	Low-side MOSFET <sup>(3)</sup>	5.9	8	10.2	A
I <sub>NEG-CL-LS</sub>	Low-side switch negative current limit	Low-side MOSFET	–7	–4.1	–1.64	A
I <sub>SD</sub>	Quiescent current, disabled	V <sub>AVIN</sub> = V <sub>PVIN</sub> = 5 V		0.1	2	μA
		V <sub>AVIN</sub> = V <sub>PVIN</sub> = 18 V		1	4.1	
I <sub>Q</sub>	Quiescent current, enabled, not switching	V <sub>AVIN</sub> = V <sub>PVIN</sub> = 18 V		9	9.7	mA
I <sub>FB</sub>	Feedback pin input bias current	V <sub>FB</sub> = 0.598 V		1		nA
G <sub>M</sub>	Error amplifier transconductance			2400		μs
A <sub>VOL</sub>	Error amplifier voltage gain			65		dB
V <sub>IH-OVP</sub>	OVP tripping threshold	Rising threshold, percentage of V <sub>OUT</sub>	103.5%	109.5%	115%	
V <sub>HYST-OVP</sub>	OVP hysteresis window	Percentage of V <sub>OUT</sub>		–4.3%		
V <sub>UVLO-HI-AVIN</sub>	AVIN UVLO rising threshold		2.84	2.93	2.987	V
V <sub>UVLO-LO-AVIN</sub>	AVIN UVLO falling threshold		2.66	2.73	2.83	V
V <sub>UVLO-HYS-AVIN</sub>	AVIN UVLO hysteresis window			195		mV
V <sub>5V0</sub>	Internal LDO1 output voltage	Measured at 5V0 pin, 1-kΩ load		4.88		V
C <sub>OUT-CAP-5V0</sub>	Recommended capacitance connected to 5V0 pin	Ceramic capacitor		1		μF

- (1) All limits are specified by design, test or statistical analysis. All electrical characteristics having room-temperature limits are tested during production with T<sub>J</sub> = 25°C. All hot and cold limits are specified by correlating the electrical characteristics to process and temperature variations and applying statistical process control.
- (2) Capacitors: low ESR surface-mount ceramic capacitors (MLCCs) are used in setting electrical characteristics.
- (3) The low-side switch current limit is ensured to be higher than the high-side current limit.

## Electrical Characteristics (continued)

All typical limits apply for  $T_J = 25^\circ\text{C}$ , and all maximum and minimum limits apply over the full operating temperature range ( $T_J = -40^\circ\text{C}$  to  $+125^\circ\text{C}$ ). Unless otherwise specified,  $V_{IN} = V_{PVIN} = V_{AVIN} = 12\text{ V}$ ,  $V_{OUT} = 3.3\text{ V}$ ,  $I_{OUT} = 0\text{ A}$ .<sup>(1)(2)(2)</sup>

PARAMETER		TEST CONDITIONS	MIN	TYP	MAX	UNIT
<b>GENERAL (continued)</b>						
$I_{\text{SHORT-5V0}}$	Short-circuit current of 5V0 pin			31		mA
$V_{2V5}$	Internal LDO2 output voltage	Measured at 2V5 pin, 1-k $\Omega$ load		2.47		V
$C_{\text{OUT-CAP-2V5}}$	Recommended capacitance connected to 2V5 pin	Ceramic capacitor		100		nF
$I_{\text{SHORT-2V5}}$	Short-circuit current of 2V5 pin			47		mA
$V_{\text{FCBOOT-D}}$	CBOOT diode forward voltage	Measured from 5V0 to CBOOT at 10 mA		0.76		V
$I_{\text{CBOOT}}$	CBOOT leakage current	$V_{\text{CBOOT}} = 5.5\text{ V}$ , not switching		0.65		$\mu\text{A}$
$T_{\text{STARTUP-DELAY}}$	Startup time from EN high to the beginning of internal soft-start			160		$\mu\text{s}$
SS	Internal soft-start	10% to 90% $V_{\text{FB}}$	1.41	2.7	4.15	ms
<b>OSCILLATOR</b>						
$F_{\text{OSC-NOM}}$	Oscillator frequency, nominal measured at SW pin	$R_{\text{FRQ}} = 61.9\text{ k}\Omega$ , 0.025%	695	750	795	kHz
$F_{\text{OSC-MAX}}$	Maximum oscillator frequency measured at SW pin	$R_{\text{FRQ}} = 28.4\text{ k}\Omega$		1500		kHz
$F_{\text{OSC-MIN}}$	Minimum oscillator frequency measured at SW pin	$R_{\text{FRQ}} = 167.5\text{ k}\Omega$		300		kHz
$T_{\text{OFF-MIN}}$	Minimum off-time measured at SW pin	$F_{\text{SW}} = 1.5\text{ MHz}$ , $V_{\text{IN}} = 3.3\text{ V}$ , $V_{\text{FB}} = 1\text{ V}$ , voltage divider ratio = 3.3		50		ns
$T_{\text{ON-MIN}}$	Minimum on-time measured at SW pin	$F_{\text{SW}} = 1.5\text{ MHz}$ , voltage divider ratio = 1		70		ns
<b>LOGIC</b>						
$V_{\text{IH-EN}}$	EN pin rising threshold		1.1	1.2	1.3	V
$V_{\text{HYST-EN}}$	EN pin hysteresis window		130	200	302	mV
$I_{\text{EN-IN}}$	EN pin input current	$V_{\text{EN}} = 12\text{ V}$		18	23	$\mu\text{A}$
$V_{\text{IH-UV-PGOOD}}$	PGOOD UV rising threshold	Percentage of $V_{\text{OUT}}$	87.5%	93%	97.5%	
$V_{\text{HYST-UV-PGOOD}}$	PGOOD UV hysteresis threshold	Percentage of $V_{\text{OUT}}$		-4.2%		
$I_{\text{OL-PGOOD}}$	PGOOD sink current	$V_{\text{OL}} = 0.2\text{ V}$		3		mA
$I_{\text{OH-PGOOD}}$	PGOOD leakage current	$V_{\text{OH}} = 18\text{ V}$			460	nA
<b>THERMAL SHUTDOWN</b>						
$T_{\text{SD}}$	Thermal shutdown <sup>(4)</sup>			160		$^\circ\text{C}$
$T_{\text{SD-HYS}}$	Thermal shutdown hysteresis <sup>(4)</sup>			10		$^\circ\text{C}$

(4) Specified by design.

## 7.6 Typical Characteristics

$V_{IN} = 12\text{ V}$ ,  $V_{OUT} = 3.3\text{ V}$ ,  $F_{SW} = 500\text{ kHz}$ ,  $T_A = 25^\circ\text{C}$ ,  $L = 3.3\ \mu\text{H}$ , and  $C_{OUT} = 100\ \mu\text{F}$  (ceramic), (unless otherwise specified)

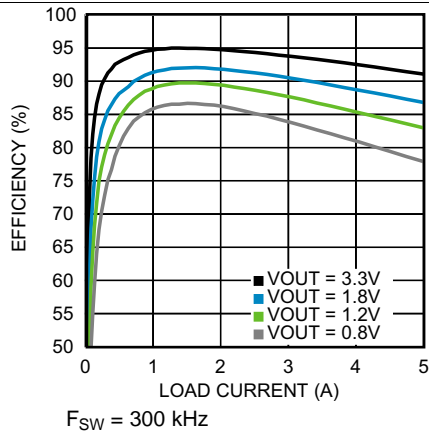

Figure 1. Efficiency with PVIN = AVIN = 5 V

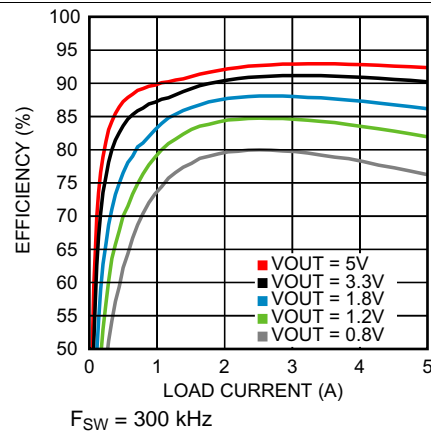

Figure 2. Efficiency with PVIN = AVIN = 12 V

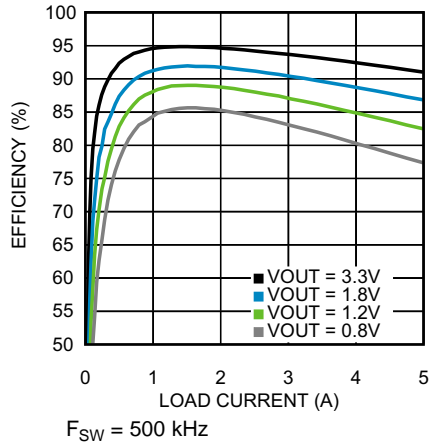

Figure 3. Efficiency with PVIN = AVIN = 5 V

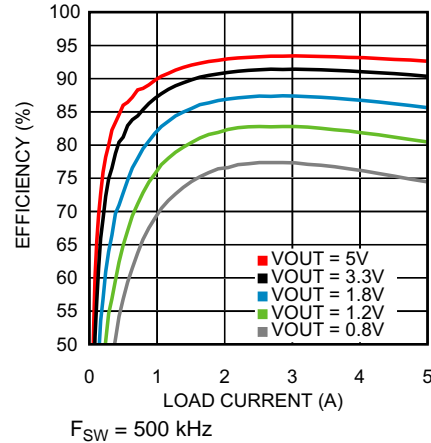

Figure 4. Efficiency with PVIN = AVIN = 12 V

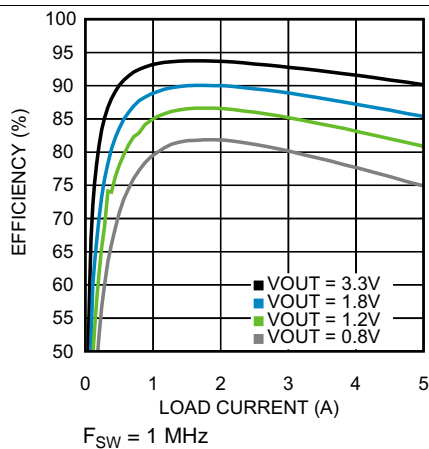

Figure 5. Efficiency with PVIN = AVIN = 5 V

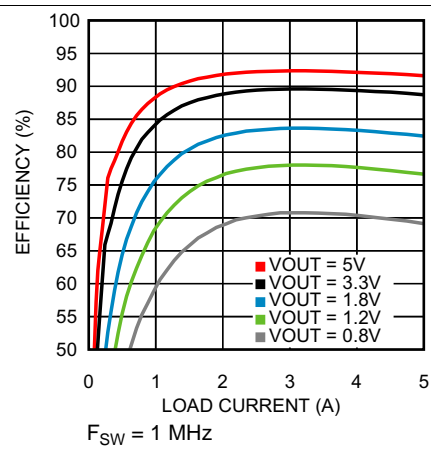

Figure 6. Efficiency with PVIN = AVIN = 12 V

Typical Characteristics (continued)

$V_{IN} = 12\text{ V}$ ,  $V_{OUT} = 3.3\text{ V}$ ,  $F_{SW} = 500\text{ kHz}$ ,  $T_A = 25^\circ\text{C}$ ,  $L = 3.3\text{ }\mu\text{H}$ , and  $C_{OUT} = 100\text{ }\mu\text{F}$  (ceramic), (unless otherwise specified)

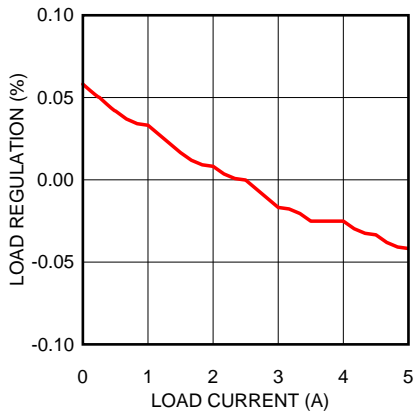

Figure 7. Load Regulation (%  $V_{OUT}$ )

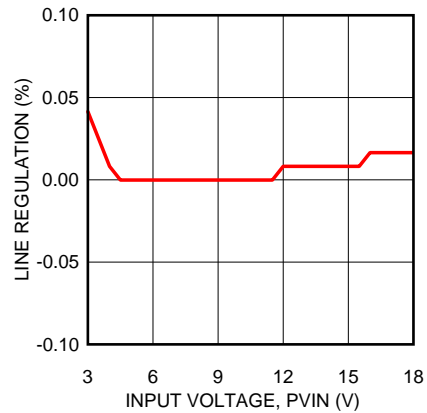

Figure 8. Line Regulation (%  $V_{OUT}$ )

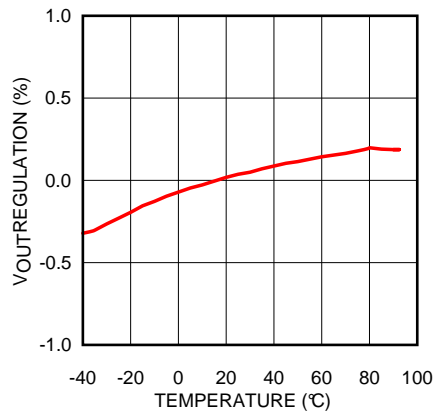

Figure 9.  $V_{OUT}$  Regulation (%) vs Temperature

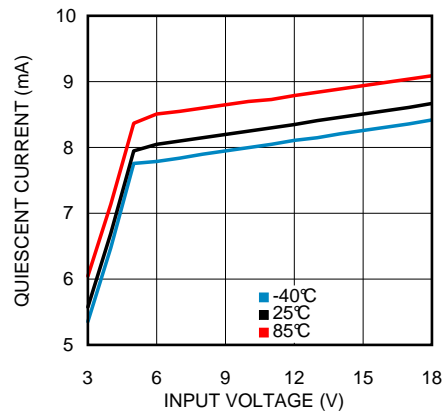

Figure 10. Input Quiescent Current, Not Switching

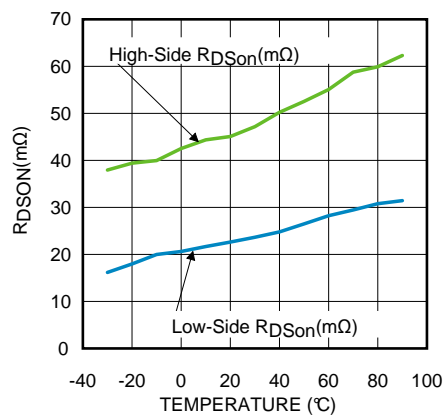

Figure 11. High-Side and Low-Side MOSFET  $R_{DS(on)}$  vs Temperature

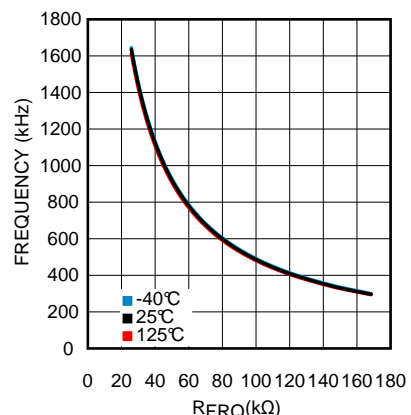

Figure 12. Switching Frequency vs  $R_{FRQ}$

Typical Characteristics (continued)

$V_{IN} = 12\text{ V}$ ,  $V_{OUT} = 3.3\text{ V}$ ,  $F_{SW} = 500\text{ kHz}$ ,  $T_A = 25^\circ\text{C}$ ,  $L = 3.3\text{ }\mu\text{H}$ , and  $C_{OUT} = 100\text{ }\mu\text{F}$  (ceramic), (unless otherwise specified)

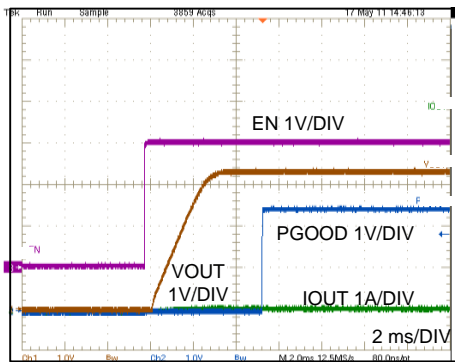

Figure 13. Soft-Start, No Load

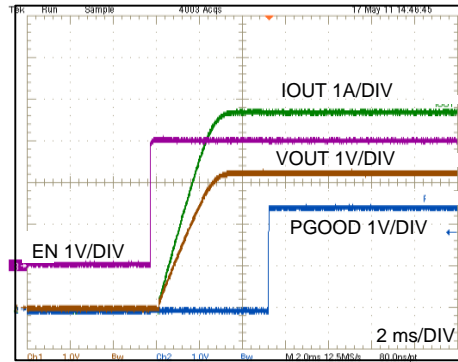

Figure 14. Soft-Start with Resistive Load

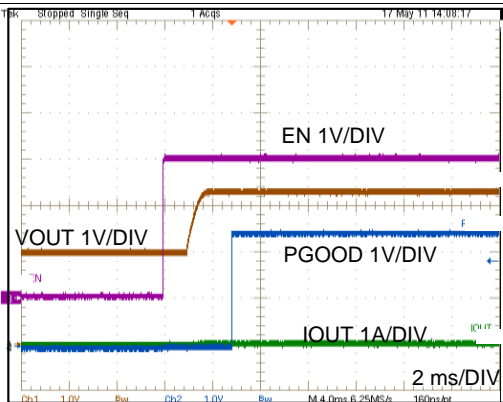

Figure 15. Soft-Start with 2-V Pre-Bias Voltage, No Load

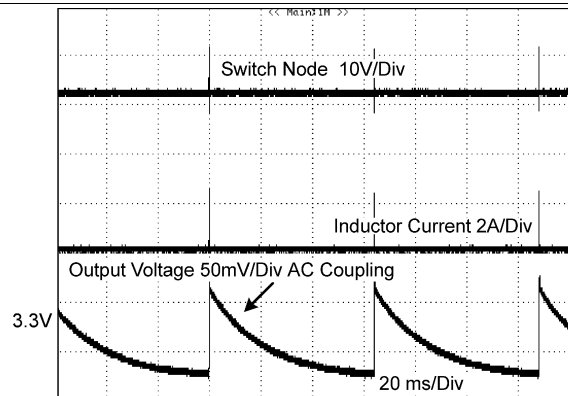

Figure 16. Switching Waveform with No Load Connected (DCM Operation)

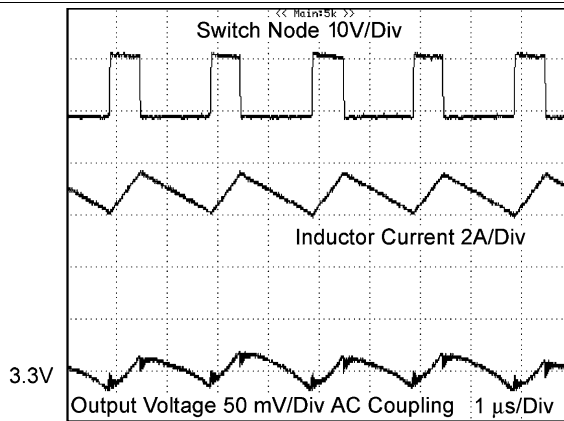

Figure 17. Switching Waveform with 5-A Load

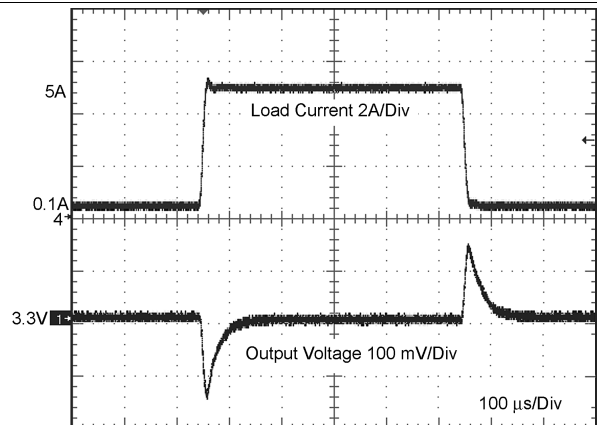

Figure 18. Load Transient Response, 0.1 A to 5 A

## 8 Detailed Description

### 8.1 Overview

The LM21305 employs a current-mode control loop with slope compensation to accurately regulate the output voltage over substantial load, line, and temperature ranges. The switching frequency is programmable between 300 kHz and 1.5 MHz through a resistor or an external synchronization signal. The LM21305 is available in a thermally-enhanced WQFN-28 packages with 0.5-mm lead pitch. The device offers high levels of integration by including power MOSFETs, low-dropout (LDO) bias supply regulators, and comprehensive fault protection features to enable highly flexible, reliable, energy-efficient, and high density regulator solutions. Multiple fault conditions are accommodated, including overvoltage, undervoltage, overcurrent, and overtemperature.

The 0.598-V reference is compared to the feedback signal at the error amplifier (EA). The PWM modulator block compares the on-time current sense information with the summation of the EA output (control voltage) and slope compensation signal. The PWM modulator outputs on and off signals to the high-side and low-side MOSFET drivers. Adaptive dead-time control is applied to the PWM output such that MOSFET shoot-through current is avoided. The drivers then amplify the PWM signals to control the integrated high-side and low-side MOSFETs.

### 8.2 Functional Block Diagram

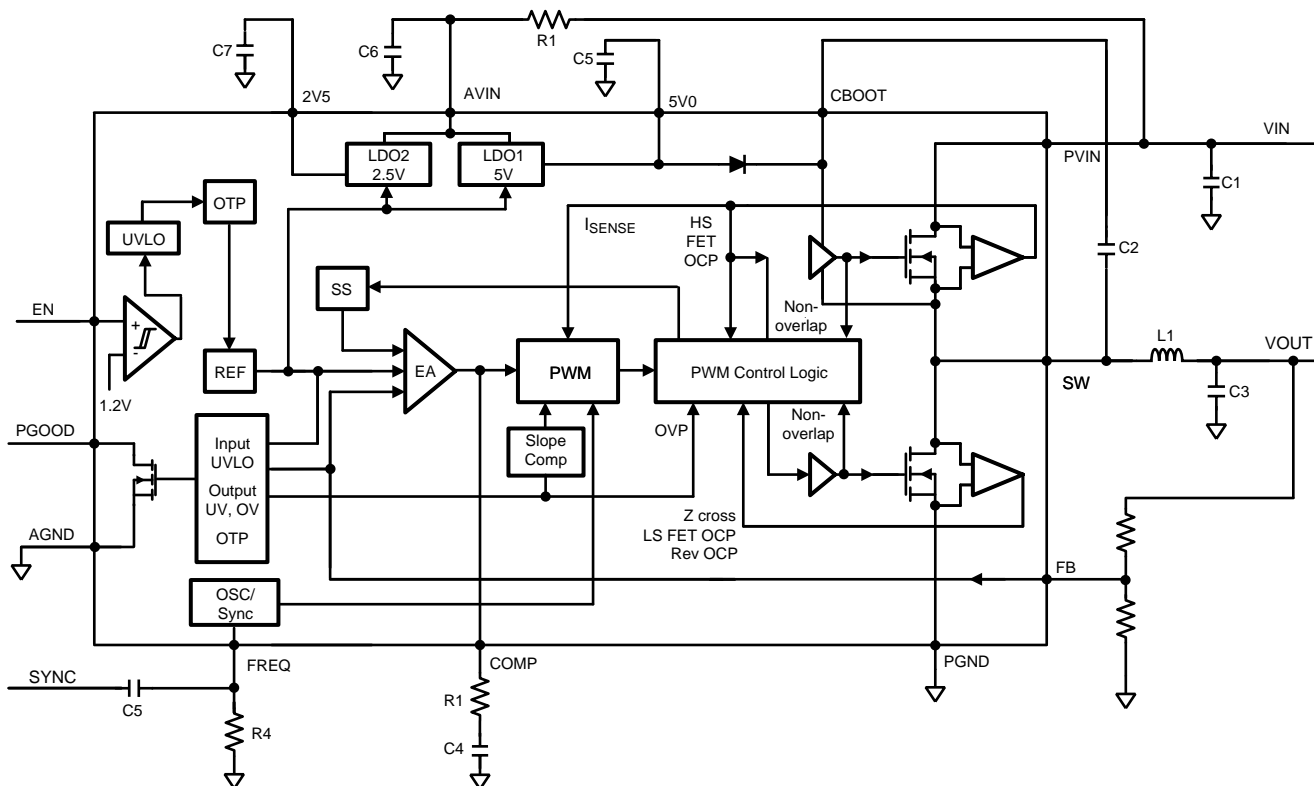

### 8.3 Feature Description

#### 8.3.1 Synchronous DC-DC Switching Converter

The LM21305 employs a buck type (step-down) dc-dc converter architecture. The device uses many advanced features to achieve excellent voltage regulation and efficiency. This easy-to-use regulator has two integrated power MOSFET switches and is capable of supplying up to 5 A of continuous output current. The regulator uses peak current-mode control with slope compensation scaled with switching frequency to optimize stability and transient response over the entire output voltage and switching frequency ranges. Peak current-mode control also provides inherent line feed-forward, cycle-by-cycle current limiting, and easy loop compensation. The switching frequency is adjusted between 300 kHz and 1.5 MHz. The device can operate with a small external LC filter and still provides very low output voltage ripple. The precision internal voltage reference allows the output to be set as low as 0.598 V. Using an external compensation circuit, the regulator crossover frequency can be selected based on the switching frequency to provide fast line and load transient response.

The switching regulator is specifically designed for highly-efficient operation throughout the load range. Synchronous rectification yields high efficiency for low output voltage and heavy load current situations, whereas discontinuous conduction mode (DCM) and diode emulation mode (DEM) enable high-efficiency conversion at lighter load current conditions. Fault protection features include: high-side and low-side MOSFET current limiting, negative current limiting on the low-side MOSFET, overvoltage protection, and thermal shutdown. The device is available in a WQFN-28 package featuring an exposed pad to aid thermal dissipation. Use the LM21305 in numerous applications to efficiently step-down from a wide range of input rails: 3 V to 18 V.

#### 8.3.2 Peak Current-Mode Control

In most applications, the peak current-mode control architecture used in the LM21305 requires only two external components to achieve a stable design. External compensation allows the user to set the crossover frequency and phase margin, thus optimizing the transient performance of the device. For duty cycles above 50%, all peak current-mode controlled buck converters require the addition of an additional ramp to avoid sub-harmonic oscillation. This linear ramp is commonly referred to as slope compensation. The amount of slope compensation in the LM21305 automatically changes depending on the switching frequency: the higher the switching frequency, the larger the slope compensation. This adaptive amplitude slope compensation feature facilitates use of smaller inductors in high-switching frequency applications where higher power density is critical.

#### 8.3.3 Switching Frequency Setting and Synchronization

The LM21305 switching regulator operates over a frequency ranging from 300 kHz to 1.5 MHz. The switching frequency is set or controlled in two ways. One is by selecting the external resistor connected to the FREQ pin to set the internal free-running oscillator frequency that determines the switching frequency. Connect an external 100-pF capacitor,  $C_{FRQ}$ , from FREQ to AGND as a noise filter, as shown in [Figure 19](#).

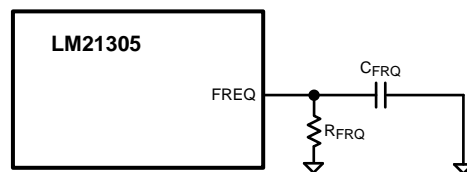

Figure 19. Switching Frequency Set by External Resistor

The other way is to synchronize the switching frequency to an external clock in the range of 300 kHz to 1.5 MHz. Apply the external clock through a 100-pF coupling capacitor,  $C_{FRQ}$ , as shown in [Figure 20](#).

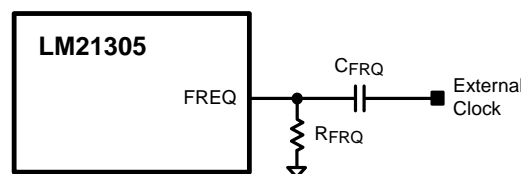

Figure 20. Switching Frequency Synchronized to the External Clock

## Feature Description (continued)

The recommendations for the external clock include peak-to-peak voltage above 1.5 V, duty cycle between 20% and 80%, and an edge rate faster than 100 ns. Circuits that use an external clock must still use a resistor connected from FREQ to AGND. The external clock frequency must be within –10% to +50% of the free-running frequency set by R<sub>FRQ</sub>. This arrangement allows the regulator to continue operating at approximately the same switching frequency if the external clock fails and the coupling capacitor on the clock side is grounded or pulled to logic high.

If the external clock fails low, timeout circuits prevent the high-side MOSFET from staying off for longer than 1.5 times the switching period,  $T_{SW} = 1 / F_{SW}$ . At the end of this timeout period, the regulator begins to switch at the frequency set by R<sub>FRQ</sub>.

If the external clock fails high, timeout circuits again prevent the high-side MOSFET from staying off longer than 1.5 times the switching period. After this timeout period, the internal oscillator takes over and switches at a fixed 1 MHz until the voltage on the FREQ pin has decayed to approximately 0.6 V. This decay follows the time constant of C<sub>FRQ</sub> and R<sub>FRQ</sub> and, when complete, the regulator switches at the frequency set by R<sub>FRQ</sub>.

### 8.3.4 Light-Load Operation

The LM21305 offers increased efficiency at light loads by allowing discontinuous conduction mode (DCM). When the load current is less than half of the inductor ripple current the device enters DCM, thus preventing negative inductor current. The output current at the critical conduction boundary is calculated according to [Equation 1](#):

$$I_{\text{BOUNDARY}} = \frac{\Delta I_L}{2} = \frac{V_{\text{OUT}} \cdot (1 - D)}{2 \cdot L \cdot F_{\text{SW}}}$$

where

- D is the duty cycle of the high-side MOSFET, equal to the high-side MOSFET on-time divided by the switching period (1)

For more details, see the [Calculating the Duty Cycle](#) subsection in the [Detailed Design Procedure](#) section. Several diagrams are provided in [Figure 21](#) that illustrate continuous conduction mode (CCM), discontinuous conduction mode (DCM), and the boundary condition. In DCM, whenever the inductor current reaches zero the SW node becomes high impedance. Ringing occurs on this pin as a result of the LC tank circuit formed by the inductor and the effective parasitic capacitance at the switch node. At very light loads, usually below 100 mA, several pulses are skipped in between switching cycles, effectively reducing the switching frequency and further improving light-load efficiency.

Feature Description (continued)

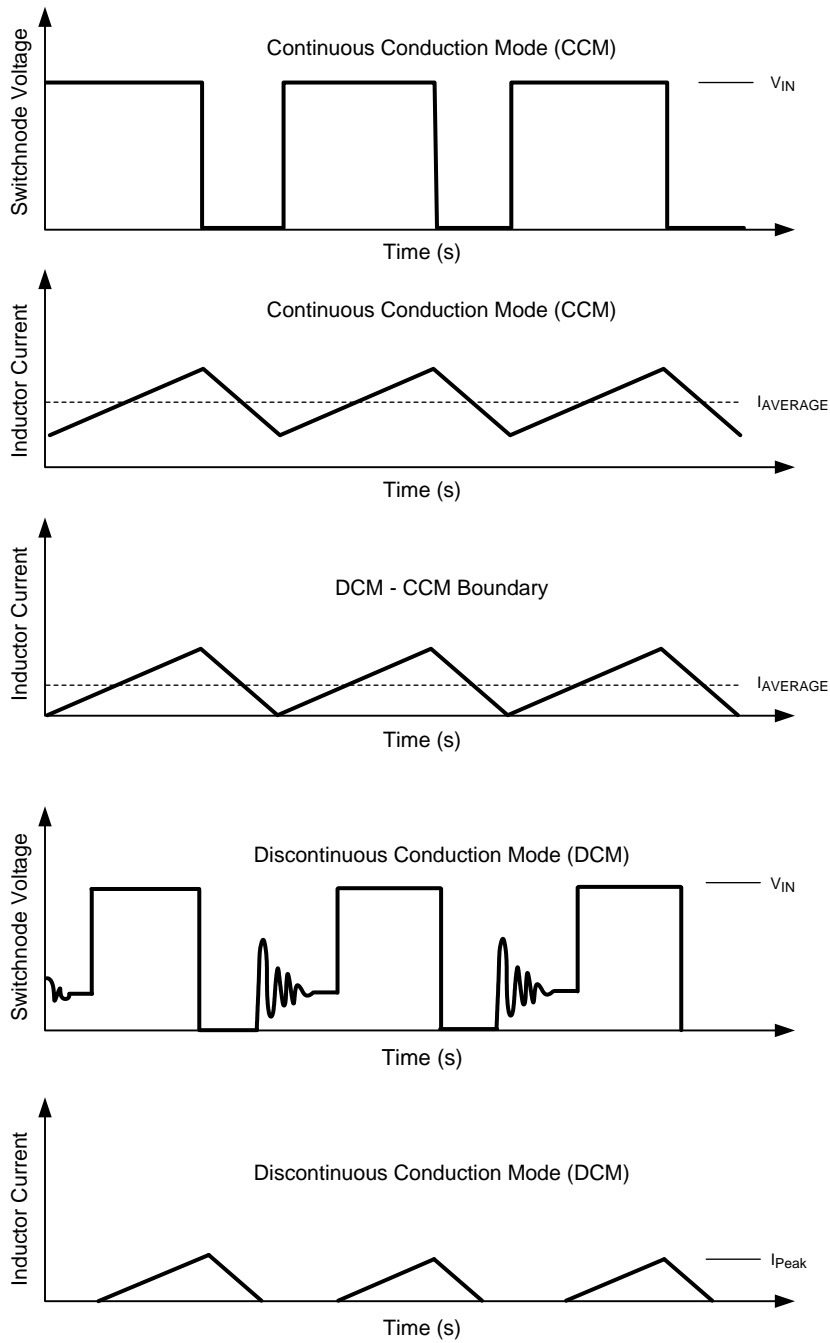

Figure 21. CCM and DCM Operation

## Feature Description (continued)

### 8.3.5 Precision Enable

The enable (EN) pin allows the output of the device to be enabled or disabled with an external control signal. This pin is a precision analog input that enables the device when the voltage exceeds 1.2 V (typical). The EN pin has 200 mV (typical) of hysteresis and disables the output when the enable voltage falls below 1.0 V (typical). If the EN pin is not used, pull this pin up to AVIN via a 10-kΩ to 100-kΩ resistor. Given that EN has a precise turn-on threshold, use an external resistor divider network from an external voltage to configure the device to turn on at a precise voltage. The precision enable circuit remains active even when the device is disabled. From [Figure 22](#), calculate the turn-on voltage with a divider using [Equation 2](#):

$$V_{\text{EN-EXT}} = 1.2 \text{ V} \cdot \left( 1 + \frac{R_{\text{EN1}}}{R_{\text{EN2}}} \right) \quad (2)$$

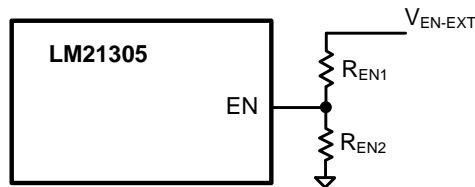

**Figure 22. Use an External Resistor Divider to Set the EN Threshold**

### 8.3.6 Device Enable, Soft-Start, and Pre-Bias Startup Capability

The LM21305 can be turned off by removing AVIN or by pulling the EN pin low. To enable the device, the EN pin must be high with the presence of AVIN and PVIN. When enabled, the device engages the internal soft-start circuit. The soft-start feature allows the regulator output to gradually reach the steady-state operating point, thus reducing stresses on the input supply and controlling startup current. Soft-start begins at the rising edge of EN with AVIN above the UVLO level. PVIN must be high when soft-start begins. The LM21305 allows AVIN to be higher than PVIN, or PVIN higher than AVIN, provided that both voltages are within their operating ranges.

Soft-start of the LM21305 is controlled internally, and 2.7 ms is typically required to finish the soft-start sequence. PGOOD transitions high after soft-start is complete.

The LM21305 is in a pre-biased state when the device initiates startup with an output voltage greater than zero. This condition often occurs in multi-rail applications, such as when powering an field-programmable gate array (FPGA), application-specific integrated circuit (ASIC), or digital signal processor (DSP) loads. In these applications, the output can be pre-biased through parasitic conduction paths from one supply rail to another. Even though the LM21305 is a synchronous converter, the device does not pull the output low when a pre-bias condition exists. During startup, the LM21305 is in diode emulation mode with the low-side MOSFET turned off when zero crossing of the inductor current is detected.

## Feature Description (continued)

### 8.3.7 Peak Current Protection and Negative Current Limiting

The LM21305 switching regulator detects the peak inductor current and limits it to 7 A, typical. To determine the average current from the peak current, the inductor size, input and output voltage, and switching frequency must be known. The average current limit is found from [Equation 3](#):

$$I_{\text{AVE-LIMIT}} = I_{\text{PEAK-LIMIT}} - \frac{\Delta I_L}{2} \quad (3)$$

When the peak inductor current sensed in the high-side MOSFET reaches the current limit threshold, an overcurrent event is triggered, the high-side MOSFET turns off and the low-side MOSFET turns on, allowing the inductor current to ramp down until the next switching cycle. When the high-side overcurrent condition persists, the output voltage is decreased by the reduced high-side MOSFET on-time.

In cases such as output short-circuit or when high-side MOSFET minimum on-time conditions are reached, the high-side MOSFET current limiting may not be sufficient to limit the inductor current. The LM21305 features an additional low-side MOSFET current limit to prevent the inductor current from running away. The low-side MOSFET current limit, 8 A typical, is set higher than the high-side current limit. When the low-side MOSFET current is higher than the limit level, PWM pulses are skipped until a low-side overcurrent is not detected during the entire low-side MOSFET conduction time. Normal PWM switching subsequently occurs when the condition is removed. High-side and low-side MOSFET current protections result in a current limit that does not aggressively foldback for brief overcurrent events, and at the same time provides frequency and voltage foldback protection during hard short-circuit conditions. The low-side MOSFET also has a negative current limit, –4.1 A typical, for secondary protection that can engage during response to overvoltage events. If the negative current limit is triggered, the low-side MOSFET is turned off. The negative current is forced to go through the high-side MOSFET body diode and quickly reduces.

### 8.3.8 PGOOD Indicator

To implement an open-drain, power-good function for sequencing and fault detection, use the PGOOD pin of the LM21305. The PGOOD open-drain MOSFET is pulled low during output undervoltage and overvoltage, UVLO, and thermal shutdown. The PGOOD function has a 16- $\mu$ s glitch filter to prevent false-flag operation for short excursions in the output voltage, such as during line and load transients. When the FB voltage is typically within –7% to 9.5% of the reference voltage, PGOOD is high. The thresholds track with the output voltage because the PGOOD comparator and the regulation loop share the same reference. Pull PGOOD high with an external resistor (10 k $\Omega$  to 100 k $\Omega$  is recommended) to an external logic supply. PGOOD can also be pulled-up to either the 5V0 rail or to the output voltage through an appropriate resistor, as desired. Tie PGOOD to AGND if the function is not required.

### 8.3.9 Internal Bias Regulators

The LM21305 contains two internal low dropout (LDO) regulators to produce internal driving and bias voltage rails from AVIN. One LDO produces 5 V to power the internal MOSFET drivers, the other LDO produces 2.5 V to power the internal bias circuitry. Bypass both the 5V0 or 2V5 LDOs to the analog ground (AGND) with an external ceramic capacitor (1  $\mu$ F and 0.1  $\mu$ F are recommended, respectively). Good bypassing is necessary to supply the high transient currents required by the power MOSFET gate drivers. Applications with high input voltage and high switching frequency increase die temperature because of the higher power dissipation within the LDOs. Connecting a load to the 5V0 or 2V5 pins is not recommended because doing so degrades their driving capability to internal circuitry, further pushing the LDOs into their RMS current ratings and increasing power dissipation and die temperature.

The LM21305 allows AVIN to be as low as 3 V, which makes the voltage at the 5V0 LDO lower than 5 V. Low supply voltage at the MOSFET drivers increases on-state resistance of the high-side and low-side power MOSFETs and reduces efficiency of the regulator. When AVIN is between 3 V and 5.5 V, the best practice is to short the 5V0 pin to AVIN to avoid the voltage drop on the internal LDO. However, the device can be damaged if the 5V0 pin is pulled to a voltage higher than 5.5 V. For efficiency considerations, use AVIN = 5 V if possible. When AVIN is above 5 V, reduced efficiency can be observed at light load because of the power loss of the LDOs. When AVIN is close to 3 V, increased MOSFET on-state resistance can reduce efficiency at high load currents.

## Feature Description (continued)

### 8.3.10 Minimum On-Time Considerations

Minimum on-time,  $T_{ON-MIN}$ , is the smallest duration of time that the high-side MOSFET conducts, typically 70 ns in the LM21305. In CCM operation, the minimum on-time limit corresponds to a minimum duty cycle as shown in [Equation 4](#):

$$D_{MIN} = F_{SW} \cdot T_{ON-MIN} \quad (4)$$

The minimum on-time becomes relevant when operating simultaneously at high input voltage and high switching frequency. As [Equation 4](#) shows, reducing the operating frequency alleviates the minimum on-time constraint. For a given switching frequency and output voltage, the maximum PVIN is approximated by [Equation 5](#):

$$V_{PVIN(max)} = \frac{V_{OUT}}{F_{SW}} \cdot \frac{1}{T_{ON-MIN}} \quad (5)$$

Similarly, if the input voltage is fixed, the maximum switching frequency without reaching the minimum on-time constraint is found by [Equation 6](#):

$$F_{SW(max)} = \frac{V_{OUT}}{V_{PVIN(max)}} \cdot \frac{1}{T_{ON-MIN}} \quad (6)$$

In rare cases where steady-state operation at minimum duty cycle is unavoidable, the regulator automatically skips cycles to keep  $V_{OUT}$  regulated, similar to light-load DCM operation.

## 8.4 Device Functional Modes

### 8.4.1 Overvoltage and Undervoltage Handling

The LM21305 has built-in undervoltage protection (UVP) and overvoltage protection (OVP) using FB voltage comparators to control the power MOSFETs. The rising OVP threshold is typically set at 109.5% of the nominal voltage setpoint. Whenever excursions occur in the output voltage above the OVP threshold, the device terminates the present on-pulse, turns on the low-side MOSFET, and pulls PGOOD low. The low-side MOSFET remains on until either the FB voltage falls back into regulation or the inductor current zero-cross is detected. If the output reaches the falling UVP threshold, typically 88.8% of the nominal setpoint, the device continues switching and PGOOD is asserted and pulls low. As detailed in the [PGOOD Indicator](#) section, PGOOD has 16  $\mu$ s of built-in deglitch time to both the rising and falling edges to avoid false tripping during transient glitches. OVP is disabled during soft-start to prevent false tripping.

### 8.4.2 Undervoltage Lockout (UVLO)

The LM21305 has a built-in undervoltage lockout (UVLO) protection circuit that prevents the device from switching until the AVIN voltage reaches 2.93 V (typical). The UVLO threshold has typically 195 mV of hysteresis that keeps the device from responding to power-on glitches during startup.

### 8.4.3 Thermal Protection

Internal thermal shutdown circuitry is provided to protect the LM21305 in the event that the maximum junction temperature is exceeded. When activated, typically at 160°C, the LM21305 turns off the power MOSFETs and resets soft-start. After the junction temperature cools to approximately 150°C, the LM21305 starts up using the normal startup routine.

## 9 Application and Implementation

### NOTE

Information in the following applications sections is not part of the TI component specification, and TI does not warrant its accuracy or completeness. TI's customers are responsible for determining suitability of components for their purposes. Customers should validate and test their design implementation to confirm system functionality.

### 9.1 Application Information

The LM21305 is a step-down dc-dc converter, typically used to convert a higher dc voltage to a lower dc voltage with a maximum output current of 5 A. The following design procedure can be used to select components for the LM21305. Alternately, the [WEBENCH® design tool](#) can be used to generate a complete design. This tool uses an iterative design procedure and has access to a comprehensive database of components that allows the tool to create an optimized design and allows the user to experiment with various design options.

As well as numerous LM21305 reference designs populated in the TI Designs reference design library, the [LM21305 QuickStart Calculator](#) is also available as a free download.

### 9.2 Typical Application

This section walks the designer through the steps necessary to select the external components to build a fully-functional, efficient, step-down power supply. As with any dc-dc converter, numerous tradeoffs are possible to optimize the design for efficiency, size, and performance. These tradeoffs are taken into account and highlighted throughout this discussion. To facilitate component selection discussions, the typical application circuit shown in [Figure 23](#) is used as a reference.

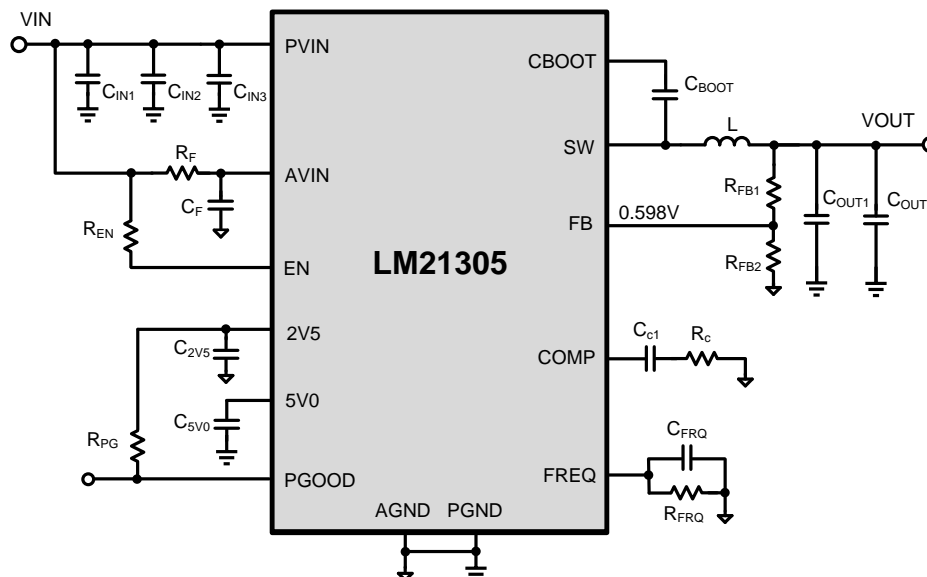

**Figure 23. LM21305 Typical Application Circuit**

## Typical Application (continued)

### 9.2.1 Design Requirements

Table 1 shows the Bill of Materials for an LM21305 converter.

**Table 1. Bill of Materials ( $F_{SW} = 500$  kHz)**

$V_{OUT}$	1.2 V	1.8 V	2.5 V	3.3 V	5 V	PACKAGE
$C_{IN1}$	TANT, 47 $\mu$ F, 25 V	TANT, 47 $\mu$ F, 25 V	TANT, 47 $\mu$ F, 25 V	TANT, 47 $\mu$ F, 25 V	TANT, 47 $\mu$ F, 25 V	CASE D
$C_{IN2}$	10 $\mu$ F, 25 V, X5R	10 $\mu$ F, 25 V, X5R	10 $\mu$ F, 25 V, X5R	10 $\mu$ F, 25 V, X5R	22 $\mu$ F, 25 V, X5R	1210
$C_{IN3}$	0.1 $\mu$ F, 25 V, X7R	0.1 $\mu$ F, 25 V, X7R	0.1 $\mu$ F, 25 V, X7R	0.1 $\mu$ F, 25 V, X7R	0.1 $\mu$ F, 25 V, X7R	1206
$C_F$	1.0 $\mu$ F, 25 V, X7R	1.0 $\mu$ F, 25 V, X7R	1.0 $\mu$ F, 25 V, X7R	1.0 $\mu$ F, 25 V, X7R	1.0 $\mu$ F, 25 V, X7R	0603
$C_{2V5}, C_{BOOT}$	0.1 $\mu$ F, 16 V, X7R	0.1 $\mu$ F, 16 V, X7R	0.1 $\mu$ F, 16 V, X7R	0.1 $\mu$ F, 16 V, X7R	0.1 $\mu$ F, 16 V, X7R	0603
$C_{5V0}$	1.0 $\mu$ F, 16 V, X7R	1.0 $\mu$ F, 16 V, X7R	1.0 $\mu$ F, 16 V, X7R	1.0 $\mu$ F, 16 V, X7R	1.0 $\mu$ F, 16 V, X7R	0603
$C_{FRQ}$	100 pF, 25 V, X7R	100 pF, 25 V, X7R	100 pF, 25 V, X7R	100 pF, 25 V, X7R	100 pF, 25 V, X7R	0603
$C_{C1}$	3.3 nF, 16 V, X7R	3.3 nF, 16 V, X7R	3.3 nF, 16 V, X7R	3.3 nF, 16 V, X7R	3.3 nF, 16 V, X7R	0603
$C_{OUT1}, C_{OUT2}$	47 $\mu$ F, 6.3 V, X5R	47 $\mu$ F, 6.3 V, X5R	47 $\mu$ F, 6.3 V, X5R	47 $\mu$ F, 6.3 V, X5R	47 $\mu$ F, 10 V, X5R	1206
L	1.5 $\mu$ H, 10 A	2.2 $\mu$ H, 10 A	2.2 $\mu$ H, 10 A	3.3 $\mu$ H, 10 A	3.3 $\mu$ H, 10 A	SMD
$R_F$	1 $\Omega$ , 5%	1 $\Omega$ , 5%	1 $\Omega$ , 5%	1 $\Omega$ , 5%	1 $\Omega$ , 5%	0603
$R_{FRQ}, R_{PG}$	100 k $\Omega$ , 1%	100 k $\Omega$ , 1%	100 k $\Omega$ , 1%	100 k $\Omega$ , 1%	100 k $\Omega$ , 1%	0603
$R_{FB2}, R_{EN}$	10 k $\Omega$ , 1%	10 k $\Omega$ , 1%	10 k $\Omega$ , 1%	10 k $\Omega$ , 1%	10 k $\Omega$ , 1%	0603
$R_C$	3.32 k $\Omega$ , 1%	4.22 k $\Omega$ , 1%	5.10 k $\Omega$ , 1%	7.15 k $\Omega$ , 1%	8.2 k $\Omega$ , 1%	0603
$R_{FB1}$	10 k $\Omega$ , 1%	20 k $\Omega$ , 1%	31.6 k $\Omega$ , 1%	45.3 k $\Omega$ , 1%	73.2 k $\Omega$ , 1%	0603

### 9.2.2 Detailed Design Procedure

#### 9.2.2.1 Setting the Output Voltage

Connect the FB pin of the LM21305 directly to  $V_{OUT}$  or through a feedback resistor divider network to scale up from the 0.598-V feedback voltage to the desired output voltage. Figure 24 shows the resistor divider connection and the FB pin.

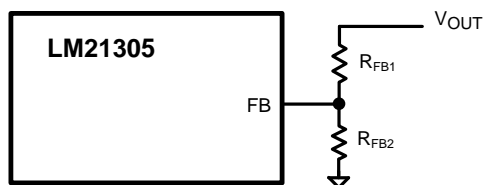

**Figure 24. Setting the Output Voltage by Resistor Divider**

The output voltage is found by Equation 7:

$$V_{OUT} = 0.598 \text{ V} \cdot \left( 1 + \frac{R_{FB1}}{R_{FB2}} \right) \quad (7)$$

For example, if the desired output voltage is 1.8 V,  $R_{FB1} = 20$  k $\Omega$  and  $R_{FB2} = 10$  k $\Omega$  can be used.

### 9.2.2.2 Calculating the Duty Cycle

The first parameter to calculate for any buck converter is duty cycle. In an ideal (no-loss) buck converter, the duty cycle is found by [Equation 8](#):

$$D_{\text{IDEAL}} = \frac{V_{\text{OUT}}}{V_{\text{PVIN}}} \quad (8)$$

In applications with low output voltage (< 1.2 V) and high load current (> 3 A), the losses must not be ignored when calculating the duty cycle. Considering the effect of conduction losses associated with the MOSFETs and inductor, the duty cycle is approximated by [Equation 9](#):

$$D = \frac{V_{\text{OUT}} + I_{\text{OUT}} \cdot (R_{\text{DSonLS}} + R_{\text{DCR}})}{V_{\text{IN}} + I_{\text{OUT}} \cdot (R_{\text{DSonLS}} - R_{\text{DSonHS}})} \quad (9)$$

$R_{\text{DSonHS}}$  and  $R_{\text{DSonLS}}$  are the on-state resistances of the high-side and low-side MOSFETs, respectively.  $R_{\text{DCR}}$  is the equivalent dc resistance of the inductor used in the output filter. Other parasitics, such as printed circuit board (PCB) trace resistance, can be included if desired.  $I_{\text{OUT}}$  is the load current and is also equal to the average inductor current. The duty cycle increases slightly when load current increases.

### 9.2.2.3 Input Capacitors

PVIN is the supply voltage for the switcher power stage and is the input source that delivers the output power to the load. The input capacitors on the PVIN rail supply the large ac switching current drawn by the switching action of the internal power MOSFETs. The input current of a buck converter is discontinuous and the ripple current supplied by the input capacitor can be quite large. The input capacitor must be rated to handle this current. To prevent large voltage transients, use a low ESR input capacitor sized for the maximum RMS current. The maximum RMS current is given by [Equation 10](#):

$$I_{\text{RMS-CIN}} = I_{\text{OUT}} \cdot \frac{\sqrt{V_{\text{OUT}} \cdot (V_{\text{PVIN}} - V_{\text{OUT}})}}{V_{\text{PVIN}}} \quad (10)$$

The power dissipation of the input capacitor is given by [Equation 11](#):

$$P_{\text{D-CIN}} = I_{\text{RMS-CIN}}^2 \cdot R_{\text{ESR-CIN}}$$

where

- $R_{\text{ESR-CIN}}$  is the ESR of the input capacitor (11)

[Equation 10](#) has a maximum at  $PV_{\text{IN}} = 2 V_{\text{OUT}}$ , where  $I_{\text{RMS-CIN}} \cong I_{\text{OUT}} / 2$  and  $D \cong 50\%$ . This simple worst-case condition is commonly used for design purposes because even significant deviations from the worst-case duty cycle operating point do not offer much difference. Note that ripple current ratings from capacitor manufacturers are often based on only 2000 hours of life. Several capacitors can be paralleled to meet size or height requirements in the design. For low input voltage applications, sufficient bulk input capacitance is needed to minimize transient effects during load current changes. A 1- $\mu\text{F}$  ceramic bypass capacitor is also recommended directly adjacent to the device between the PVIN and PGND pins. See [Figure 38](#) and the [Layout Guidelines](#) section.

### 9.2.2.4 AVIN Filter

Add an RC filter to prevent any switching noise on PVIN from interfering with the internal analog circuits connected to AVIN, as shown in the schematic of [Figure 23](#) and denoted by components  $R_{\text{F}}$  and  $C_{\text{F}}$ . There is a practical limit to the resistance of resistor  $R_{\text{F}}$  because the AVIN pin draws a short 60-mA burst of current during startup. If  $R_{\text{F}}$  is too large, the resulting voltage drop can trigger the UVLO comparator. A recommended 1- $\Omega$  resistor and 1- $\mu\text{F}$  capacitor provides approximately 10 dB of attenuation at a 500-kHz switching frequency.

### 9.2.2.5 Switching Frequency Selection

The LM21305 supports a wide range of switching frequencies: 300 kHz to 1.5 MHz. The choice of switching frequency is usually a compromise between conversion efficiency and the size of the circuit. A lower switching frequency implies reduced switching losses (including gate drive and switch transition losses) and usually results in higher overall efficiency. However, a higher switching frequency allows use of smaller LC output filter components and thus a more compact design. Lower inductance also helps transient response (higher large-signal slew rate of the inductor current) and reduces the DCR losses. The optimal switching frequency is usually a tradeoff in a given application and thus must be determined on a case-by-case basis. In practice, the optimal switching frequency is related to input voltage, output voltage, most common load current level, external component choices, and circuit size requirements. The choice of switching frequency is also limited if an operating condition triggers  $T_{ON-MIN}$  or  $T_{OFF-MIN}$ ; see the [Minimum On-Time Considerations](#) section for more detail.

Use [Equation 12](#) or [Figure 25](#) to calculate the resistance to obtain a desired frequency of operation.

$$F_{SW} \text{ [kHz]} = 31000 \cdot R_{FRQ}^{-0.9} \text{ [k}\Omega\text{]} \quad (12)$$

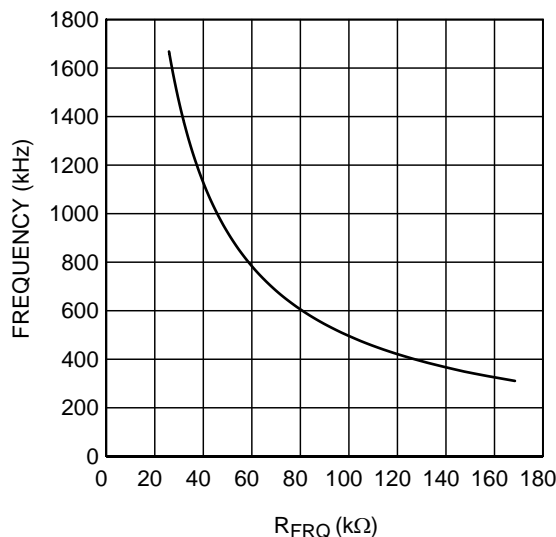

**Figure 25. External Resistor Selection to Set the Switching Frequency**

### 9.2.2.6 Filter Inductor

A general recommendation for the filter inductor in an LM21305 application is to keep a peak-to-peak ripple current between 25% and 50% of the maximum load current of 5 A. The filter inductor must have a sufficiently high saturation current rating and a DCR as low as possible. Calculate the peak-to-peak inductor current ripple current from [Equation 13](#):

$$\Delta I_L = \frac{V_{OUT} \cdot (1-D)}{F_{SW} \cdot L} \quad (13)$$

Select the inductance as shown by [Equation 14](#):

$$\frac{V_{OUT} \cdot (1-D)}{F_{SW} \cdot 0.5 \cdot I_{OUT(max)}} \leq L \leq \frac{V_{OUT} \cdot (1-D)}{F_{SW} \cdot 0.25 \cdot I_{OUT(max)}} \quad (14)$$

The peak inductor current at full load corresponds to the maximum output current plus the ripple current, as shown in [Equation 15](#):

$$I_{L(max)} = I_{OUT(max)} + \frac{\Delta I_{L(max)}}{2} \quad (15)$$

Choose an inductor with a saturation current rating at maximum operating temperature that is higher than the overcurrent protection limit. In general, having lower inductance is desirable in switching power supplies because lower inductance equates to faster transient response, lower DCR, and reduced size for more compact designs. However, too low of an inductance implies large inductor ripple current such that OCP is falsely triggered at the full load. Larger inductor ripple current also implies higher output voltage ripple.

When the inductance is determined, choose the type of inductor to meet the application requirements. Ferrite designs have very low core losses and are preferred at high switching frequencies, thus design goals can then concentrate on copper loss and preventing saturation. However, ferrite core material saturates hard, meaning that inductance collapses abruptly when the saturation current is exceeded. The hard saturation results in an large increase in inductor ripple current and output voltage ripple. Do not allow the core to saturate!

### 9.2.2.7 Output Capacitor

The LM21305 is designed to function with a wide variety of LC filters. Using as little output capacitance as possible is generally desirable to keep cost and size down. Choose the output capacitor,  $C_{OUT}$ , carefully because it directly affects the steady-state output voltage ripple, loop stability, and the voltage overshoot and undershoot during a load transient.

The output voltage ripple is essentially composed of two parts, resistive and capacitive. More specifically, the inductor ripple current flowing through the equivalent series resistance (ESR) of the output capacitors gives a resistive component as given by Equation 16:

$$\Delta V_{OUT-ESR} = \Delta I_L \cdot R_{ESR} \quad (16)$$

Also, consider the inductor ripple current charging and discharging the output capacitors, producing a capacitive ripple voltage component given by Equation 17:

$$\Delta V_{OUT-C} = \frac{\Delta I_L}{8 \cdot F_{SW} \cdot C_{OUT}} \quad (17)$$

Figure 26 shows an illustration of the two ripple components. The actual peak-to-peak voltage ripple is smaller than the sum of the two peaks because the two ripple components are not in phase. The cumulative output ripple is given by Equation 18:

$$\Delta V_{OUT} = \Delta I_L \sqrt{R_{ESR}^2 + \left( \frac{1}{8 \cdot F_{SW} \cdot C_{OUT}} \right)^2} \quad (18)$$

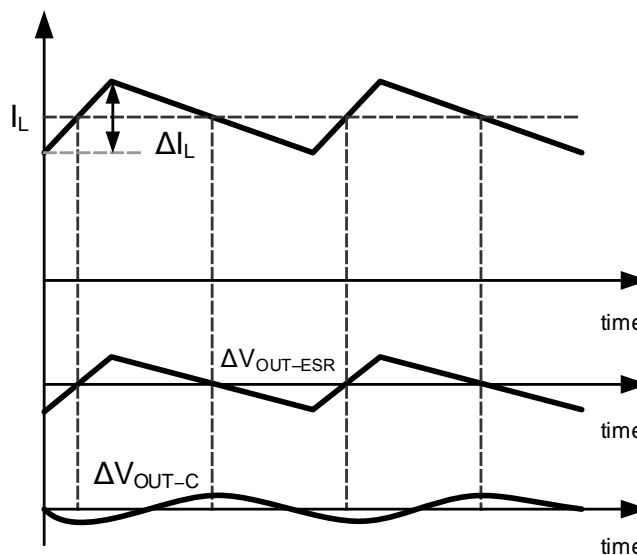

**Figure 26. Inductor Current and Two Components of Output Voltage Ripple**

Output capacitance is usually limited by system transient performance specifications if the system requires tight voltage regulation with the presence of large current steps and fast slew rates. When a fast or large load transient occurs, output capacitors provide the required charge before the inductor current slews to the appropriate level. The initial output voltage deviation is equal to the load current step multiplied by ESR.  $V_{OUT}$  continues to droop until the control loop response increases the inductor current to supply the load. To maintain a small overshoot or undershoot during a load transient, small ESR and large capacitance are desired. However, these factors also come with the penalty of higher cost and size. Thus, the motivation is to seek a fast control loop response to reduce the output voltage deviation.

One or more ceramic capacitors are generally recommended because these capacitors have very low ESR and remain capacitive up to high frequencies. Choose an X5R or X7R capacitor dielectric to maintain proper tolerance. Other types of capacitors (such as tantalum, POSCAP, and OSCON) are used if bulk energy storage is required. Such electrolytic capacitors have lower ESR zero frequency (relative to ceramic capacitors) that can influence the control loop, particularly if the zero frequency is close to the desired crossover target. If high switching frequency and high loop crossover frequency are warranted, an all-ceramic capacitor design is often more appealing.

### 9.2.2.8 Efficiency Considerations

The efficiency of a switching regulator is defined as the output power divided by the input power times 100%. Efficiency is also found by using [Equation 19](#):

$$\eta = 1 - \frac{P_{DISS}}{P_{IN}} \quad (19)$$

Analyzing individual losses is often useful to determine what is limiting the efficiency and what change can produce the most improvement. Although all dissipative elements in the circuit produce losses, three main sources usually account for most of the losses in LM21305-based converters: 1) conduction losses; 2) switching and gate drive losses; and 3) bias losses. Conduction losses are the  $I^2R$  losses in parasitic resistances including MOSFET on-state resistances  $R_{DSon}$ , equivalent inductor dc resistance  $R_{DCR}$ , and PCB trace resistances  $R_{TRACE}$ . Approximate the conduction loss using [Equation 20](#):

$$P_{COND} = I_{OUT}^2 (D \cdot R_{DSonHS} + (1-D) \cdot R_{DSonLS} + R_{DCR} + R_{TRACE}) \quad (20)$$

Lower the total conduction loss by reducing these parasitic resistances. For example, the LM21305 is designed to have low  $R_{DSon}$  internal MOSFET switches. Keep the inductor DCR low, and ensure that the traces that conduct the current are wide, thick, and as short as possible. Obviously, conduction losses increasingly affect the efficiency at heavier loads. RMS currents through the input and output capacitor ESR also generate loss.

Switching losses include all the dissipation caused by the switching action of the two power MOSFETs. Each time the switch node swings from low to high or vice versa, charges are applied or removed from the parasitic capacitance from the SW node to GND. Each time a power MOSFET gate is switched from low to high to low again, a packet of charge moves from 5V0 to ground. Furthermore, each time a power MOSFET is turned on or off, a transition loss is generated related to the overlap of voltage and current. The low-side MOSFET body diode generates reverse recovery loss and dead-time conduction loss. All of these losses must be evaluated and carefully considered to design a high-efficiency switching power converter. Because these losses only occur during switching, reducing the switching frequency always helps reduce the switching loss and the resultant improvement in efficiency is more pronounced at lighter load.

The current drawn from AVIN is equivalent to  $I_{DRIVE}$  and the associated power loss is  $V_{AVIN} \times I_{DRIVE}$  because the 5V0 rail is an LDO output from AVIN. The other portion of AVIN power loss is the bias current through the 2V5 rail that equals  $V_{AVIN} \times I_{BIAS}$ . Powering AVIN from a 5-V system rail provides an optimal tradeoff between bias power loss and switching loss.

**9.2.2.9 Load Current Derating When Duty Cycle Exceeds 50%**

The LM21305 is optimized for lower duty cycle operation (for example, high input-to-output voltage ratio). The high-side MOSFET is designed to be half the size of the low-side MOSFET, thus optimizing the relative levels of switching loss in the high-side switch and the conduction loss in the low-side switch. The continuous current rating of the low-side switch is the maximum load current of 5 A, whereas the high-side MOSFET is rated at 2.5 A. If the LM21305 is operating with duty cycles higher than 50%, the maximum output current must be derated, as shown in Equation 21.

$$I_{OUT(max)} = 5 \cdot \text{Min}[(1.5 - D), 1] \tag{21}$$

Derating of the maximum load current when  $D > 50\%$  is also shown in Figure 27.

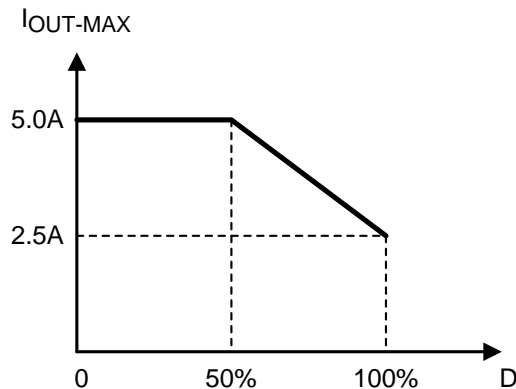

Figure 27. LM21305 Maximum Load Current Derating when  $D > 50\%$

**9.2.2.10 Control Loop Compensation**

This section does not provide a rigorous analysis of current-mode control, but rather a simplified yet relatively accurate method to determine the control loop compensation network. The LM21305 employs a peak current-mode controller and, therefore, the control loop block diagram representation involves two feedback loops, as shown in Figure 28.

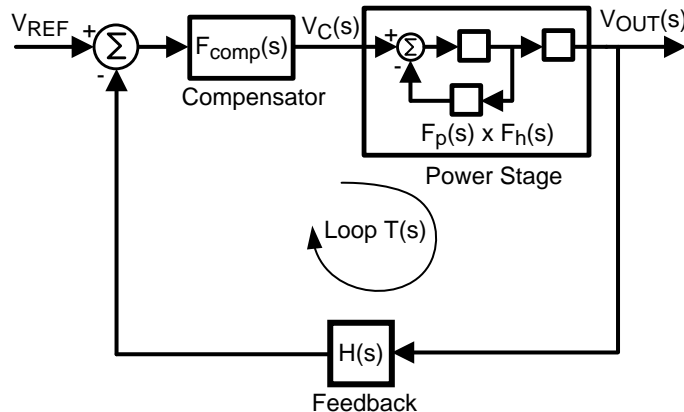

Figure 28. Control Block Diagram of a Peak Current-Mode Controlled Buck Converter

The inner feedback loop derives its feedback from the sensed inductor current and the outer loop monitors the output voltage. The LM21305 compensation components installed from COMP to AGND are shown in Figure 29. The purpose of the compensator block is to stabilize the control loop and achieve high performance in terms of load transient response, audio susceptibility, and output impedance. The LM21305 typically requires only a single resistor  $R_C$  and capacitor  $C_{C1}$  for compensation. However, depending on the location of the power stage ESR zero, a second (small) capacitor,  $C_{C2}$ , may be required to create a high-frequency pole.

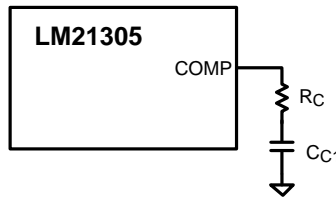

Figure 29. LM21305 Compensation Network

The overall loop transfer function is a product of the power stage transfer function, internal amplifier gains and the feedback network transfer function and is expressed by Equation 22:

$$T(s) = \text{Gain}_0 \cdot F_p(s) \cdot F_h(s) \cdot F_{\text{comp}}(s)$$

where

- $\text{Gain}_0$  includes all the dc gains in the loop,
- $F_p(s)$  represents the power stage pole and zero (including the inner current loop),
- $F_h(s)$  represents the sampling effect in such a current-mode converter, and
- $F_{\text{comp}}(s)$  is the compensation network impedance

(22)

Figure 30 shows an asymptotic approximation plot of the loop gain.

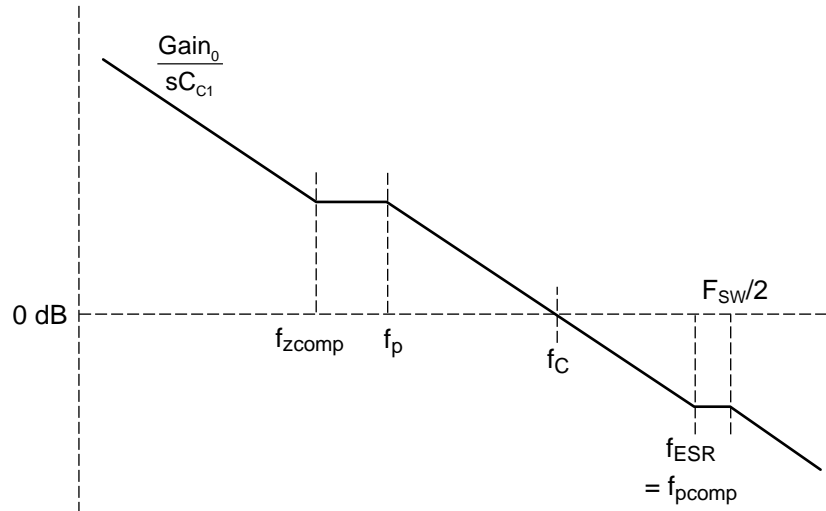

Figure 30. LM21305 Loop Gain Asymptotic Approximation

The loop gain determines both static and dynamic performance of the converter. The power stage response is fixed by the selection of the power components and the compensator is therefore designed around the power stage response to achieve the desired loop response. The goal is to design a control loop characteristic with high crossover frequency (or loop bandwidth) and adequate gain and phase margins under all operation conditions.

### 9.2.2.11 Compensation Components Selection

To select the compensation components, a desired crossover frequency must be selected. Select  $f_C$  equal to or lower than 1/6 of the switching frequency. The effect of  $F_h(s)$  can be ignored to simplify the design. The capacitor ESR zero is also assumed to be at least three times higher than  $f_C$ . Calculate the compensation resistor using [Equation 23](#):

$$R_C = \frac{1}{\text{Gain}_0} \cdot \frac{f_C}{f_p} = 302 \cdot \frac{V_{\text{OUT}}}{V_{\text{FB}}} \cdot f_C \cdot C_{\text{OUT}} \quad (23)$$

$C_{C1}$  does not affect the crossover frequency  $f_C$ , but sets the compensator zero  $f_{z\text{comp}}$  and affects the phase margin of the loop. For a fast design,  $C_{C1} = 4.7$  nF gives adequate performance in most LM21305 applications. Higher  $C_{C1}$  capacitance gives higher phase margin but at the expense of longer transient response settling time. Set the compensation zero no higher than  $f_C / 3$  to ensure enough phase margin, as implied by [Equation 24](#):

$$C_{C1} = \frac{3}{2 \cdot \pi \cdot R_C \cdot f_C} \quad (24)$$

### 9.2.2.12 Plotting the Loop Gain

To include the effect of  $F_h(s)$  and the ESR zero, plot the complete loop gain using a software tool (such as MATLAB, Mathcad, or Excel). Determine the loop gain constituents as follows. First, calculate the dc gain of the power stage using [Equation 25](#):

$$\text{Gain}_0 = 0.021 \cdot \frac{V_{\text{OUT}}}{V_{\text{FB}}} \cdot \frac{R_{\text{OUT}}}{1 + \frac{R_{\text{OUT}}}{F_{\text{SW}} \cdot L} \cdot (m_C D' - 0.5)} \quad (25)$$

where  $m_C$  for the LM21305 is given by [Equation 26](#):

$$m_C = 1 + \frac{4 \cdot F_{\text{SW}} \cdot L}{V_{\text{IN}} - V_{\text{OUT}}} \quad (26)$$

and  $D' = 1 - D$ . Use the minimum  $R_{\text{OUT}}$  in the calculation of  $R_{\text{OUT}} = V_{\text{OUT}} / I_{\text{OUT}}$ .

$F_p(s)$  is expressed using [Equation 27](#):

$$F_p(s) = \frac{1 + s / (2 \cdot \pi \cdot f_{\text{ESR}})}{1 + s / (2 \cdot \pi \cdot f_p)} \quad (27)$$

where the power stage pole (including slope compensation effect) and ESR zero frequencies are given respectively by [Equation 28](#) and [Equation 29](#):

$$f_p = \frac{1}{2 \cdot \pi \cdot C_{\text{OUT}}} \left( \frac{1}{R_{\text{OUT}}} + \frac{1}{F_{\text{SW}} \cdot L} (m_C \cdot D' - 0.5) \right) \quad (28)$$

$$f_{\text{ESR}} = \frac{1}{2 \cdot \pi \cdot C_{\text{OUT}} \cdot R_{\text{ESR}}} \quad (29)$$

The high frequency behavior  $F_h(s)$  is expressed by [Equation 30](#):

$$F_h(s) = \frac{1}{1 + \frac{s}{\omega_n \cdot Q_p} + \frac{s^2}{\omega_n^2}} \quad (30)$$

where the relevant frequency and quality factor are given by [Equation 31](#)

$$\omega_n = \pi \cdot F_{\text{SW}}$$

$$Q_p = \frac{1}{\pi \cdot (m_C \cdot D' - 0.5)} \quad (31)$$

The compensation network impedance is given in [Equation 32](#):

$$F_{\text{COMP}}(s) = R_C + \frac{1}{s \cdot C_{C1}} \quad (32)$$

Using the above equations, it becomes an easy task to plot the loop gain  $T(s)$  and determine the loop performance metrics, such as crossover frequency and phase margin.

### 9.2.2.13 High Frequency Considerations

$F_h(s)$  represents the additional magnitude and phase drop around  $F_{\text{SW}} / 2$  caused by the switching behavior of the current-mode converter.  $F_h(s)$  contains a pair of double poles with quality factor  $Q_p$  at half of the switching frequency. Good practice is to check that  $Q_p$  is between 0.15 and 2, ideally around 0.6. If  $Q_p$  is too high, the resonant peaking at  $F_{\text{SW}} / 2$  can become severe and coincide with sub-harmonic oscillations in the duty cycle and inductor current. If  $Q_p$  is too low, the two complex poles split, the converter begins to function as a voltage-mode controlled converter, and the compensation scheme used above must be adjusted.

In a typical converter design with ceramic output capacitors, the ESR zero frequency,  $f_{\text{ESR}}$ , is typically three times higher than the desired crossover frequency  $f_c$ . If  $f_{\text{ESR}}$  is lower than  $F_{\text{SW}} / 2$ , add a capacitor  $C_{C2}$  between COMP and AGND to give a high-frequency pole, as shown in [Equation 33](#):

$$C_{C2} = \frac{1}{2 \cdot \pi \cdot R_C \cdot f_{\text{ESR}}} \quad (33)$$

Select  $C_{C2}$  much smaller than  $C_{C1}$  to avoid affecting the compensation zero. The high-frequency pole also provides high-frequency noise attenuation at COMP.

### 9.2.2.14 Bootstrap Capacitor

Use a capacitor between CBOOT and SW to supply the gate drive charge when the high-side MOSFET is turning on. Ensure that the capacitor is large enough to supply the charge without significant voltage drop. A 0.1- $\mu\text{F}$  ceramic bootstrap capacitor is recommended in LM21305 applications.

### 9.2.2.15 5V0 and 2V5 Capacitors

The 5V0 and 2V5 pins are internal bias rail LDO outputs. As previously mentioned, the two LDOs are used for internal circuits only and must not be substantially loaded. Output capacitors are needed to stabilize the LDOs. Ceramic capacitors within a specified range must be used to meet stability requirements. Choose an X5R or X7R dielectric rated for the required operating temperature range. Use [Table 2](#) to choose a suitable LDO output capacitor.

**Table 2. Bias Rail LDO Capacitance**

RAIL	NOMINAL VOLTAGE	CAPACITOR (Recommended Capacitance, Dielectric, Minimum Voltage Rating)
5V0	4.88 V	1 $\mu\text{F} \pm 20\%$ , X7R, 16 V
2V5	2.47 V	0.1 $\mu\text{F} \pm 20\%$ , X7R, 10 V

### 9.2.2.16 Maximum Ambient Temperature

As with any power conversion device, the LM21305 dissipates internal power while operating. The effect of this power dissipation is to raise the internal temperature of the converter above ambient. The internal die temperature,  $T_J$ , is a function of the ambient temperature,  $T_A$ , the power dissipation and the effective thermal resistance,  $R_{\theta JA}$ , of the device and PCB combination. The maximum internal die temperature for the LM21305 is 125°C, thus establishing a limit on the maximum device power dissipation and therefore the load current at high ambient temperatures. Equation 34 shows the relationships between these parameters.

$$I_{OUT} = \frac{(T_J - T_A)}{R_{\theta JA}} \cdot \frac{\eta}{(1 - \eta)} \cdot \frac{1}{V_{OUT}} \quad (34)$$

High ambient temperatures and large values of  $R_{\theta JA}$  reduce the maximum available output current. If the junction temperature exceeds 160°C, the LM21305 cycles in and out of thermal shutdown. If thermal shutdown occurs, then this shutdown is a sign of inadequate heat-sinking or excessive power dissipation in the device. Improve PCB heat-sinking by using more thermal vias, a larger board, or more heat-spreading layers within that board.

As stated in application note *Semiconductor and IC Package Thermal Metrics*, [SPRA953](#), the values given in the [Thermal Information](#) table are not valid for design purposes to estimate the thermal performance of the application. The values reported in the [Thermal Information](#) table are measured under a specific set of conditions that are seldom obtained in an actual application. The effective  $R_{\theta JA}$  is a critical parameter and depends on many factors (such as power dissipation, air temperature, PCB area, copper heat-sink area, number of thermal vias under the package, air flow, and adjacent component placement). The LM21305 uses an advanced package with a heat-spreading pad (DAP) on the bottom. This pad must be soldered directly to the PCB copper ground plane to provide an effective heat-sink, as well as a proper electrical connection. Use the resources listed in [Resources for Thermal PCB Design](#) as a guide to optimal thermal PCB design and estimating  $R_{\theta JA}$  for a given application environment.

### 9.2.3 Application Curves

For additional details on the waveforms shown in this section, see *AN-2175 LM21305 POL Demonstration Module and Reference Design*, [SNVA497](#).

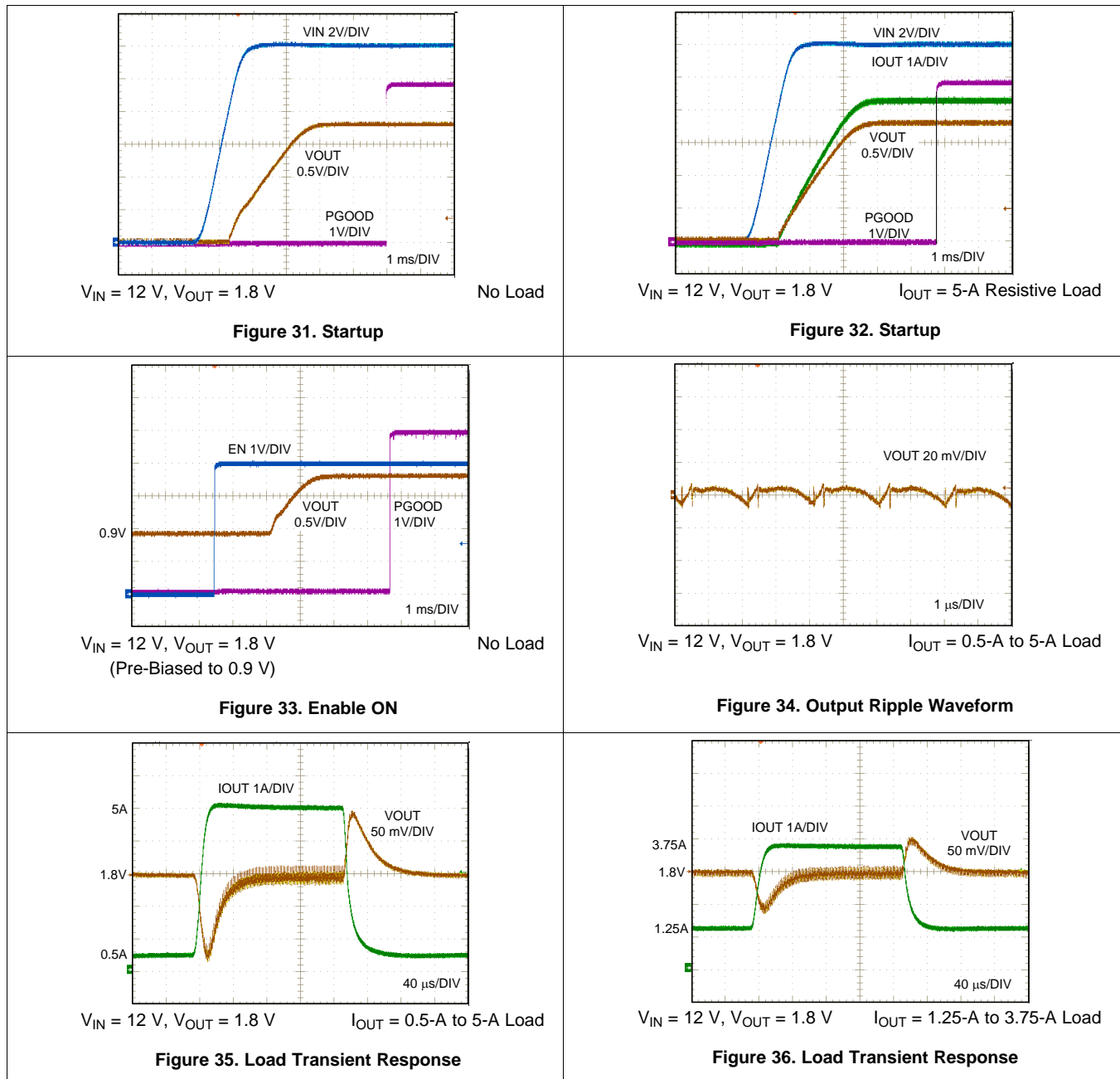

## 10 Power Supply Recommendations

The LM21305 converter is designed to operate from an input voltage supply range between 3 V and 18 V. The characteristics of the input supply must be compatible with the [Absolute Maximum Ratings](#) and [Recommended Operating Conditions](#) tables. In addition, the input supply must be capable of delivering the required input current to the loaded regulator. Estimate the average input current with [Equation 35](#).

$$I_{IN} = \frac{V_{OUT} \cdot I_{OUT}}{V_{IN} \cdot \eta}$$

where

- $\eta$  is the efficiency (35)

If the regulator is connected to the input supply through long wires or PCB traces with large impedance, special care is required to achieve good performance. The parasitic inductance and resistance of the input cables can have an adverse affect on the operation of the regulator. The parasitic inductance, in combination with the low ESR ceramic input capacitors, can form an under-damped resonant circuit. This circuit can cause overvoltage transients at the PVIN pin each time the input supply is cycled on and off. The parasitic resistance causes the PVIN voltage to dip when the load on the regulator is switched on or exhibits a transient. If the regulator is operating close to the minimum input voltage, this dip can cause false UVLO fault triggering and a system reset. The best way to solve these types of issues is to reduce the distance from the input supply to the regulator and use an aluminum or tantalum input capacitor in parallel with the ceramics. The moderate ESR of the electrolytic capacitors helps to damp the input resonant circuit and reduce any voltage overshoots. A value in the range of 20  $\mu$ F to 100  $\mu$ F is usually sufficient to provide input damping and help to hold the input voltage steady during large load transients.

Sometimes an EMI input filter is used in front of the regulator, which can lead to instability as well as some of the effects mentioned previously, unless carefully designed. The user guide *Simple Success with Conducted EMI for DC-DC Converters*, [SNVA489](#), provides helpful suggestions when designing an input filter for any switching regulator.

## 11 Layout

### 11.1 Layout Guidelines

PC board layout is an important and critical part of any dc-dc converter design. The performance of any switching converter depends as much upon the layout of the PCB as the component selection. Poor layout disrupts the performance of a dc-dc converter and surrounding circuitry by contributing to EMI, ground bounce, resistive voltage loss in the traces, and thermal problems. Erroneous signals can reach the dc-dc converter, possibly resulting in poor regulation or instability. There are several paths that conduct high slew-rate currents or voltages that can interact with stray inductance or parasitic capacitance to generate noise and EMI or degrade the power-supply performance.

The following guidelines serve to help users to design a PCB with the best power conversion performance, thermal performance, and minimized generation of unwanted EMI.

1. Locate the input capacitors as close as possible to the PVIN and PGND pins, and place the inductor as close as possible to the SW pins and output capacitors. This placement is to minimize the area of switching current loops and reduce the resistive loss of the high current path. Based on the LM21305 pinout, place a 1- $\mu$ F to 10- $\mu$ F ceramic capacitor right by pins 1, 2, and 7, across the SW node trace, as an addition to the bulk input capacitors. Using a size 1206 or 1210 capacitor allows enough copper width for the SW node to be routed underneath the capacitor for good conduction (see the LM21305 evaluation board layout detailed in application note *AN-2042 LM21305 Evaluation Board*, [SNVA432](#)).
2. Keep the SW node area small. Keep the copper area connecting the SW pin to the inductor as short and wide as possible. At the same time, minimize the total area of this node to help mitigate radiated EMI. Place the inductor as close as possible to the SW pins.
3. Use a solid ground plane on layer two of the PCB, particularly underneath the LM21305 and power stage components. This plane functions as a noise shield and also as a heat dissipation path.
4. Make input and output power bus connections as wide and short as possible to reduce any voltage drops on the input or output of the converter and to improve efficiency. Use copper planes on top to connect the multiple PVIN pins and PGND pins together.
5. Provide enough PCB area for proper heat-sinking. As stated in the [Maximum Ambient Temperature](#) section, use enough copper area to ensure a low  $R_{\theta JA}$  commensurate with the maximum load current and ambient temperature. Make the top and bottom PCB layers with two ounce copper and no less than one ounce. Use an array of heat-sinking vias to connect the exposed pad (DAP) to the ground plane on the bottom PCB layer. If the PCB has multiple copper layers (recommended), connect these thermal vias to the inner layer heat-spreading ground planes.
6. Route the feedback trace from VOUT to the feedback divider resistors away from the SW pin and inductor to avoid contaminating this feedback signal with switching noise. This routing is most important when high resistances are used to set the output voltage. Routing the feedback trace on a different layer than the inductor and SW node trace is recommended such that a ground plane exists between the feedback trace and inductor or SW node polygon to provide further cancellation of EMI on the feedback trace.
7. If voltage accuracy at the load is important, ensure that the feedback voltage sense is made directly at the load terminals. Doing so corrects for voltage drops in the PCB planes and traces and provides optimal output voltage setpoint accuracy and load regulation. Placing the resistor divider closer to the FB node, rather than close to the load, is always better because the FB node is the input to the error amplifier and is thus noise sensitive. COMP is a noise-sensitive node and the compensation components must be located as close as possible to the device.
8. Use short, low-inductance traces for the  $C_{BOOT}$  capacitor. Locate  $C_{BOOT}$  as close as possible to the CBOOT and SW pins.
9. Place the bypass capacitors for the 5V0 and 2V5 rails close to their respective pins.
10. Place the frequency set resistor and its associated capacitor close to the FREQ pin.
11. See [PCB Layout Resources](#) for additional guidelines.

## Layout Guidelines (continued)

### 11.1.1 Compact PCB Layout for EMI Reduction

Radiated EMI generated by high  $di/dt$  components relates to pulsing currents in switching converters. The larger area covered by the path of a pulsing current, the more electromagnetic emission is generated. The key to minimize radiated EMI is to identify the pulsing current path and minimize the area of that path.

The main switching loop of the LM21305 power stage is denoted by #1 in [Figure 37](#). The topological architecture of a buck converter means that particularly high  $di/dt$  current flows in loop #1, and it becomes mandatory to reduce the parasitic inductance of this loop by minimizing its effective loop area. For loop #2 however, the  $di/dt$  through inductor  $L_F$  and capacitor  $C_{OUT}$  is naturally limited by the inductor. Keeping the area of loop #2 small is not nearly as important as that of loop #1. Also important are the gate drive loops of the low-side and high-side MOSFETs, which are inherently tight by virtue of the integrated power MOSFETs and gate drivers of the LM21305.

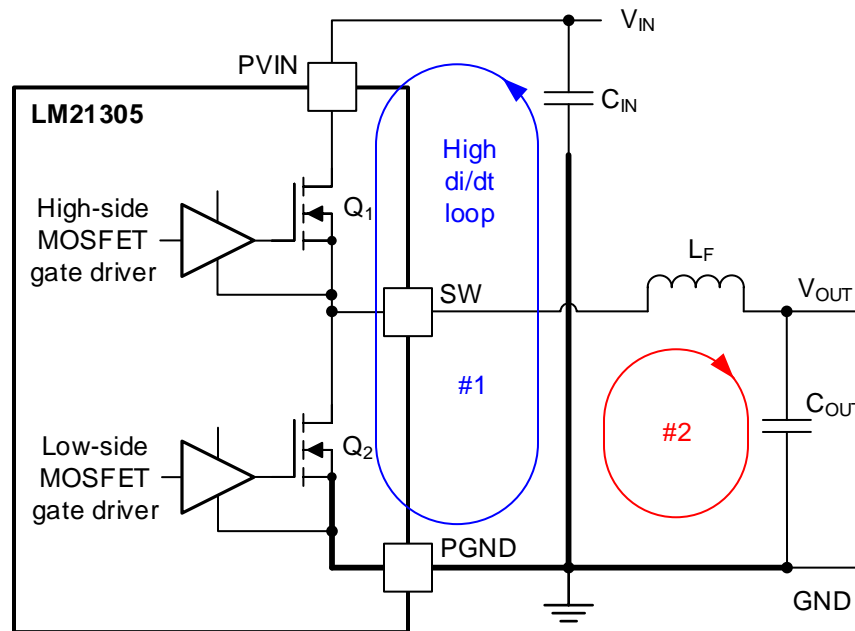

**Figure 37. DC-DC Buck Regulator with Power Stage Circuit Switching Loops**

High-frequency ceramic bypass capacitors at the input side provide primary path for the high  $di/dt$  components of the pulsing current. Placing ceramic bypass capacitors as close as possible to the PVIN and PGND pins is the key to EMI reduction. Keep the SW trace connecting to the inductor as short as possible, and just wide enough to carry the load current without excessive heating. Use short, thick traces or copper pours (shapes) for current conduction path to minimize parasitic resistance. Place the output capacitors close to the V<sub>OUT</sub> side of the inductor and route the return using GND plane copper back to the LM21305 PGND pin and exposed PAD.

### 11.1.2 Ground Plane and Thermal Design Considerations

As mentioned previously, using one of the middle layers as a solid ground plane is recommended. A ground plane provides shielding for sensitive circuits and traces. This plane also provides a quiet reference potential for the control circuitry. Connect the AGND and PGND pins to the ground plane using vias right next to the bypass capacitors. The PGND pins are connected to the source of the internal low-side power MOSFET. Connect these pins directly to the return terminals of the input and output capacitors. The PGND net contains noise at the switching frequency and can bounce because of load variations. The PGND trace, as well as PVIN and SW traces, must be constrained to one side of the ground plane. The other side of the ground plane contains much less noise and can be used for sensitive routes.

## Layout Guidelines (continued)

Provide adequate device heat-sinking by using the exposed pad (DAP) of the LM21305 as the primary thermal path. Use a minimum 4-by-4 array of 10 mil thermal vias to connect the DAP to the system ground plane for heat-sinking. Evenly distribute the vias under the DAP. Use as much copper as possible for system ground plane on the top and bottom layers for best heat dissipation. A four-layer board with copper thickness, starting from the top, of 2 oz, 1 oz, 1 oz, 2 oz and with proper layout provides low impedance, proper shielding, and low thermal resistance. See [Resources for Thermal PCB Design](#) for additional thermal design guidelines.

## 11.2 Layout Example

[Figure 38](#) and [Figure 39](#) show an example of an LM21305 PCB layout. Only the top and bottom layer copper and top silkscreen are shown. For more details, see application note [AN-2175 LM21305 POL Demonstration Module and Reference Design, SNVA497](#).

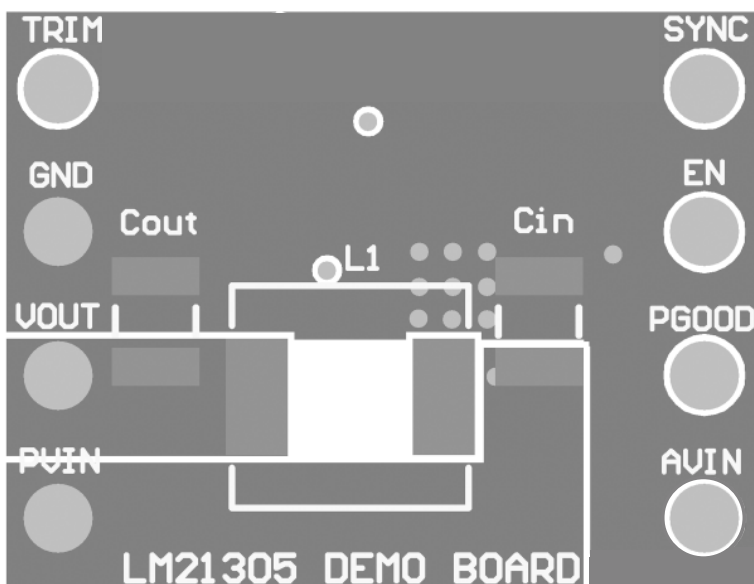

Figure 38. PCB Top Layer Copper and Silkscreen

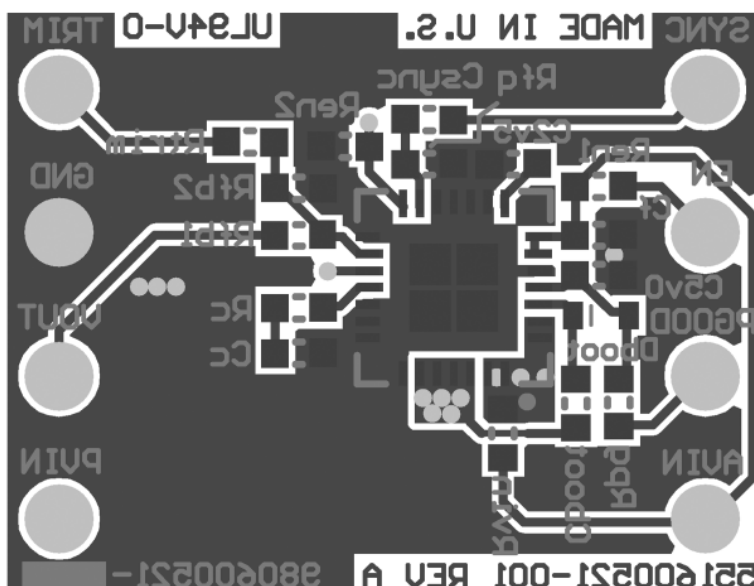

Figure 39. PCB Bottom Layer Copper and Silkscreen

## 12 Device and Documentation Support

### 12.1 Device Support

#### 12.1.1 Development Support

- [LM21305 Quickstart Design Tool](#)
- [PowerLab™](#)
- [WEBENCH® Design Center](#)

### 12.2 Documentation Support

#### 12.2.1 Related Documentation

- [AN-2042 LM21305 Evaluation Board](#), [SNVA432](#)
- [AN-2175 LM21305 POL Demonstration Module and Reference Design](#), [SNVA497](#)
- [AN-2162 Simple Success with Conducted EMI from DC-DC Converters](#), [SNVA489](#)
- [AN-1187 Leadless Leadframe Package \(LLP\)](#), [SNOA401](#)
- [Using New Thermal Metrics Application Report](#), [SBVA025](#)
- [6/4-Bit VID Programmable Current DAC for Point of Load Regulators with Adjustable Start-Up Current](#), [SNVS822](#)
- [Semiconductor and IC Package Thermal Metrics](#), [SPRA953](#)

#### 12.2.2 PCB Layout Resources

- [AN-1149 Layout Guidelines for Switching Power Supplies](#), [SNVA021](#)
- [AN-1229 Simple Switcher PCB Layout Guidelines](#), [SNVA054](#)
- [Constructing Your Power Supply – Layout Considerations](#), [SLUP230](#)
- [Low Radiated EMI Layout Made SIMPLE with LM4360x and LM4600x](#), [SNVA721](#)

#### 12.2.3 Resources for Thermal PCB Design

- [AN-2020 Thermal Design By Insight, Not Hindsight](#), [SNVA419](#)
- [AN-1520 A Guide to Board Layout for Best Thermal Resistance for Exposed Pad Packages](#), [SNVA183](#)
- [SPRA953B Semiconductor and IC Package Thermal Metrics](#), [SPRA953](#)
- [SNVA719 Thermal Design made Simple with LM43603 and LM43602](#), [SNVA719](#)
- [SLMA002 PowerPAD™ Thermally Enhanced Package](#), [SLMA002](#)
- [SLMA004 PowerPAD Made Easy](#), [SLMA004](#)
- [SBVA025 Using New Thermal Metrics](#), [SBVA025](#)

### 12.3 Community Resources

The following links connect to TI community resources. Linked contents are provided "AS IS" by the respective contributors. They do not constitute TI specifications and do not necessarily reflect TI's views; see TI's [Terms of Use](#).

**TI E2E™ Online Community** *TI's Engineer-to-Engineer (E2E) Community*. Created to foster collaboration among engineers. At [e2e.ti.com](#), you can ask questions, share knowledge, explore ideas and help solve problems with fellow engineers.

**Design Support** *TI's Design Support* Quickly find helpful E2E forums along with design support tools and contact information for technical support.

### 12.4 Trademarks

PowerPAD, E2E are trademarks of Texas Instruments.  
WEBENCH is a registered trademark of Texas Instruments.  
All other trademarks are the property of their respective owners.

## 12.5 Electrostatic Discharge Caution



These devices have limited built-in ESD protection. The leads should be shorted together or the device placed in conductive foam during storage or handling to prevent electrostatic damage to the MOS gates.

## 12.6 Glossary



[SLYZ022](#) — *TI Glossary*.

This glossary lists and explains terms, acronyms, and definitions.

## 13 Mechanical, Packaging, and Orderable Information

The following pages include mechanical, packaging, and orderable information. This information is the most current data available for the designated devices. This data is subject to change without notice and revision of this document. For browser-based versions of this data sheet, refer to the left-hand navigation.

**PACKAGING INFORMATION**

Orderable Device	Status (1)	Package Type	Package Drawing	Pins	Package Qty	Eco Plan (2)	Lead finish/ Ball material (6)	MSL Peak Temp (3)	Op Temp (°C)	Device Marking (4/5)	Samples
LM21305SQ/NOPB	ACTIVE	WQFN	RSG	28	1000	RoHS & Green	SN	Level-2A-260C-4 WEEK	-40 to 85	21305SQ	
LM21305SQE/NOPB	ACTIVE	WQFN	RSG	28	250	RoHS & Green	SN	Level-2A-260C-4 WEEK	-40 to 85	21305SQ	
LM21305SQX/NOPB	ACTIVE	WQFN	RSG	28	4500	RoHS & Green	SN	Level-2A-260C-4 WEEK	-40 to 85	21305SQ	

(1) The marketing status values are defined as follows:

**ACTIVE:** Product device recommended for new designs.

**LIFEBUY:** TI has announced that the device will be discontinued, and a lifetime-buy period is in effect.

**NRND:** Not recommended for new designs. Device is in production to support existing customers, but TI does not recommend using this part in a new design.

**PREVIEW:** Device has been announced but is not in production. Samples may or may not be available.

**OBSELETE:** TI has discontinued the production of the device.

(2) **RoHS:** TI defines "RoHS" to mean semiconductor products that are compliant with the current EU RoHS requirements for all 10 RoHS substances, including the requirement that RoHS substance do not exceed 0.1% by weight in homogeneous materials. Where designed to be soldered at high temperatures, "RoHS" products are suitable for use in specified lead-free processes. TI may reference these types of products as "Pb-Free".

**RoHS Exempt:** TI defines "RoHS Exempt" to mean products that contain lead but are compliant with EU RoHS pursuant to a specific EU RoHS exemption.

**Green:** TI defines "Green" to mean the content of Chlorine (Cl) and Bromine (Br) based flame retardants meet JS709B low halogen requirements of <=1000ppm threshold. Antimony trioxide based flame retardants must also meet the <=1000ppm threshold requirement.

(3) MSL, Peak Temp. - The Moisture Sensitivity Level rating according to the JEDEC industry standard classifications, and peak solder temperature.

(4) There may be additional marking, which relates to the logo, the lot trace code information, or the environmental category on the device.

(5) Multiple Device Markings will be inside parentheses. Only one Device Marking contained in parentheses and separated by a "~" will appear on a device. If a line is indented then it is a continuation of the previous line and the two combined represent the entire Device Marking for that device.

(6) Lead finish/Ball material - Orderable Devices may have multiple material finish options. Finish options are separated by a vertical ruled line. Lead finish/Ball material values may wrap to two lines if the finish value exceeds the maximum column width.

**Important Information and Disclaimer:**The information provided on this page represents TI's knowledge and belief as of the date that it is provided. TI bases its knowledge and belief on information provided by third parties, and makes no representation or warranty as to the accuracy of such information. Efforts are underway to better integrate information from third parties. TI has taken and continues to take reasonable steps to provide representative and accurate information but may not have conducted destructive testing or chemical analysis on incoming materials and chemicals. TI and TI suppliers consider certain information to be proprietary, and thus CAS numbers and other limited information may not be available for release.

In no event shall TI's liability arising out of such information exceed the total purchase price of the TI part(s) at issue in this document sold by TI to Customer on an annual basis.

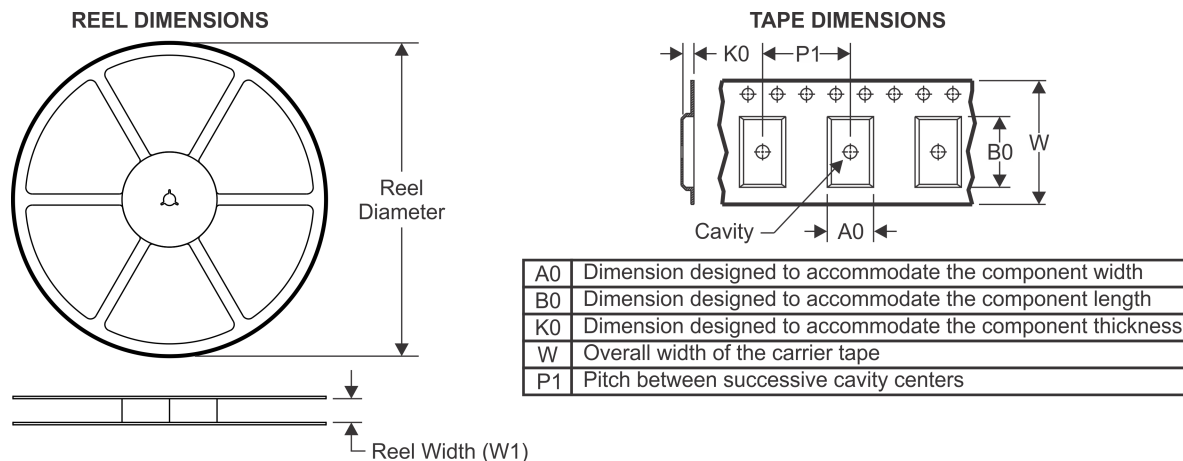
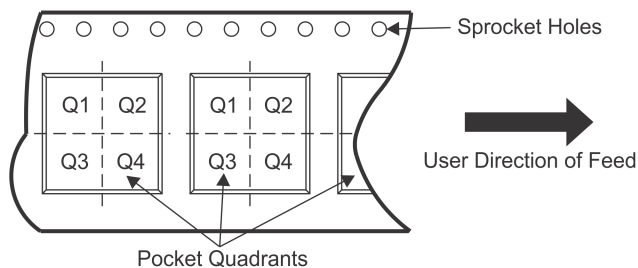
**TAPE AND REEL INFORMATION**

**QUADRANT ASSIGNMENTS FOR PIN 1 ORIENTATION IN TAPE**

\*All dimensions are nominal

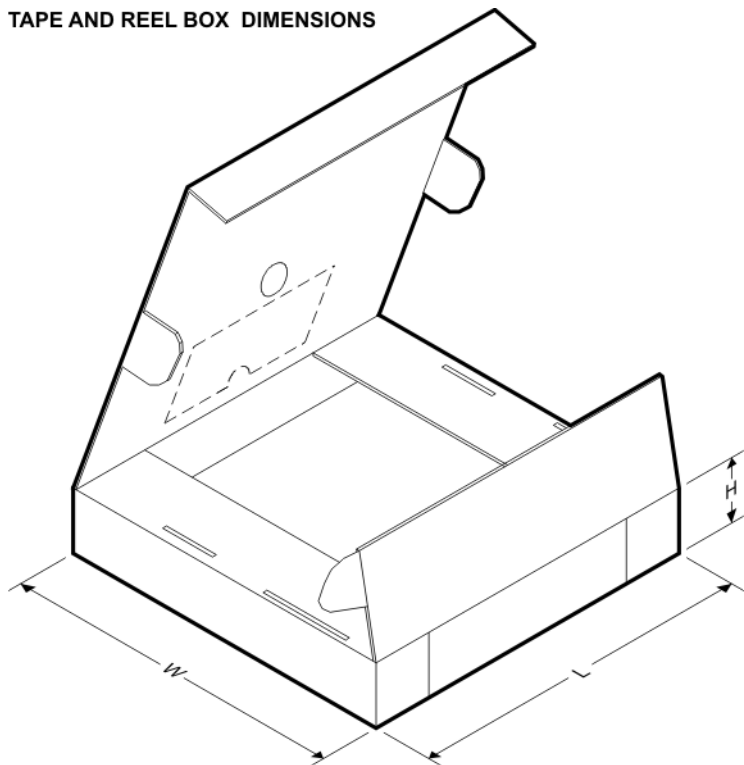
Device	Package Type	Package Drawing	Pins	SPQ	Reel Diameter (mm)	Reel Width W1 (mm)	A0 (mm)	B0 (mm)	K0 (mm)	P1 (mm)	W (mm)	Pin1 Quadrant
LM21305SQ/NOPB	WQFN	RSG	28	1000	178.0	12.4	5.3	5.3	1.3	8.0	12.0	Q1
LM21305SQE/NOPB	WQFN	RSG	28	250	178.0	12.4	5.3	5.3	1.3	8.0	12.0	Q1
LM21305SQX/NOPB	WQFN	RSG	28	4500	330.0	12.4	5.3	5.3	1.3	8.0	12.0	Q1

**TAPE AND REEL BOX DIMENSIONS**

\*All dimensions are nominal

Device	Package Type	Package Drawing	Pins	SPQ	Length (mm)	Width (mm)	Height (mm)
LM21305SQ/NOPB	WQFN	RSG	28	1000	208.0	191.0	35.0
LM21305SQE/NOPB	WQFN	RSG	28	250	213.0	191.0	55.0
LM21305SQX/NOPB	WQFN	RSG	28	4500	853.0	449.0	35.0

# THERMAL PAD MECHANICAL DATA

RSG (S-PWQFN-N28)

PLASTIC QUAD FLATPACK NO-LEAD

## THERMAL INFORMATION

This package incorporates an exposed thermal pad that is designed to be attached directly to an external heatsink. The thermal pad must be soldered directly to the printed circuit board (PCB). After soldering, the PCB can be used as a heatsink. In addition, through the use of thermal vias, the thermal pad can be attached directly to the appropriate copper plane shown in the electrical schematic for the device, or alternatively, can be attached to a special heatsink structure designed into the PCB. This design optimizes the heat transfer from the integrated circuit (IC).

For information on the Quad Flatpack No-Lead (QFN) package and its advantages, refer to Application Report, QFN/SON PCB Attachment, Texas Instruments Literature No. SLUA271. This document is available at [www.ti.com](http://www.ti.com).

The exposed thermal pad dimensions for this package are shown in the following illustration.

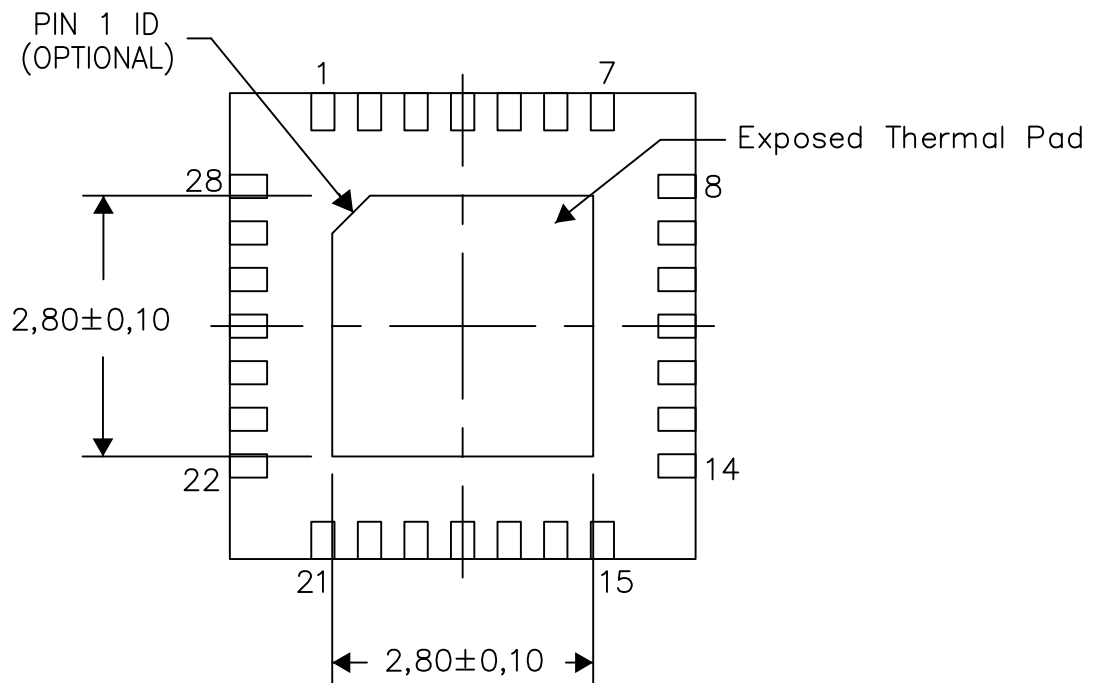

Bottom View

Exposed Thermal Pad Dimensions

4221534-3/B 04/15

NOTE: All linear dimensions are in millimeters

## IMPORTANT NOTICE AND DISCLAIMER

TI PROVIDES TECHNICAL AND RELIABILITY DATA (INCLUDING DATA SHEETS), DESIGN RESOURCES (INCLUDING REFERENCE DESIGNS), APPLICATION OR OTHER DESIGN ADVICE, WEB TOOLS, SAFETY INFORMATION, AND OTHER RESOURCES "AS IS" AND WITH ALL FAULTS, AND DISCLAIMS ALL WARRANTIES, EXPRESS AND IMPLIED, INCLUDING WITHOUT LIMITATION ANY IMPLIED WARRANTIES OF MERCHANTABILITY, FITNESS FOR A PARTICULAR PURPOSE OR NON-INFRINGEMENT OF THIRD PARTY INTELLECTUAL PROPERTY RIGHTS.

These resources are intended for skilled developers designing with TI products. You are solely responsible for (1) selecting the appropriate TI products for your application, (2) designing, validating and testing your application, and (3) ensuring your application meets applicable standards, and any other safety, security, regulatory or other requirements.

These resources are subject to change without notice. TI grants you permission to use these resources only for development of an application that uses the TI products described in the resource. Other reproduction and display of these resources is prohibited. No license is granted to any other TI intellectual property right or to any third party intellectual property right. TI disclaims responsibility for, and you will fully indemnify TI and its representatives against, any claims, damages, costs, losses, and liabilities arising out of your use of these resources.

TI's products are provided subject to [TI's Terms of Sale](#) or other applicable terms available either on [ti.com](http://ti.com) or provided in conjunction with such TI products. TI's provision of these resources does not expand or otherwise alter TI's applicable warranties or warranty disclaimers for TI products.

TI objects to and rejects any additional or different terms you may have proposed.

Mailing Address: Texas Instruments, Post Office Box 655303, Dallas, Texas 75265  
Copyright © 2021, Texas Instruments Incorporated